

Brought to you by Eris Studios
NOT FOR RESALE

AUTOMATIC TRANSMISSION

OIL PUMP

Brought to you by Eris Studios
NOT FOR RESALE

1. Oil Pump

A: CONSTRUCTION

The pump consists of a paracoid rotor pair, a housing and a cover. The inner rotor has nine teeth and the outer rotor has ten teeth.

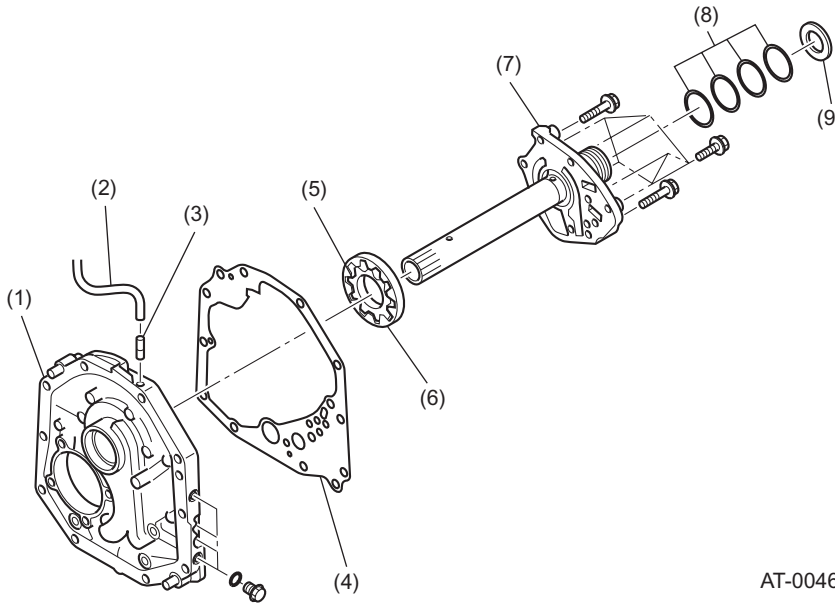

AT-00461

- | | | |
|----------------------|-----------------|--------------------|
| (1) Oil pump housing | (4) Gasket | (7) Oil pump cover |
| (2) Hose | (5) Inner rotor | (8) Seal ring |
| (3) Nipple | (6) Outer rotor | (9) Thrust bearing |

B: FUNCTION

- The pump draws automatic transmission fluid (ATF) from the oil pan through the oil strainer located under the control valve assembly. The ATF then flows through a passage in the transmission case, and after passing through the oil pump housing and oil pump cover, it enters the suction port.
- As the inner rotor rotates, the outer rotor also rotates. This motion causes the ATF to be sucked up through the suction port and discharged from the discharge port.
- The discharged ATF flows through a passage in the oil pump cover and then a passage in the oil pump housing. It then goes through a passage in the transmission case to the control valve assembly, from which the ATF is directed to various clutches, brakes, and torque converter lockup clutch for acting as hydraulic fluid and lubricating oil. Part of the ATF also flows to the manual valve, from where it is distributed to the circuit corresponding to the range selected by the selector lever.
- As engine speed increases, the delivery rate of the oil pump also increases.

OIL PUMP

AUTOMATIC TRANSMISSION

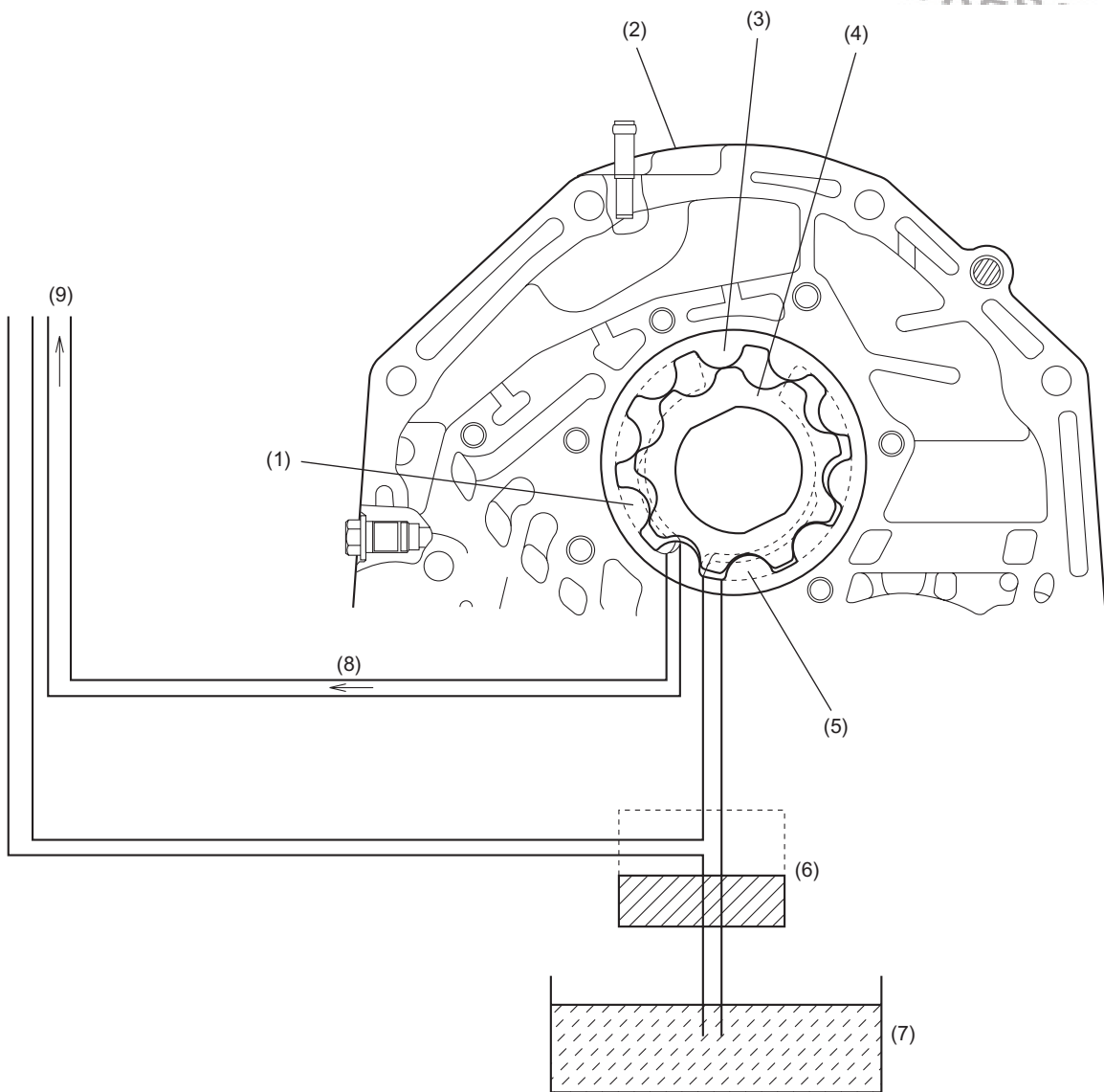

AT-01774

- | | |
|----------------------|----------------------|
| (1) Delivery port | (6) Oil strainer |
| (2) Oil pump housing | (7) Oil pan |
| (3) Outer rotor | (8) Line pressure |
| (4) Inner rotor | (9) To control valve |
| (5) Suction port | |

Brought to you by Eris Studios
NOT FOR RESALE

2. Reverse Clutch

A: CONSTRUCTION

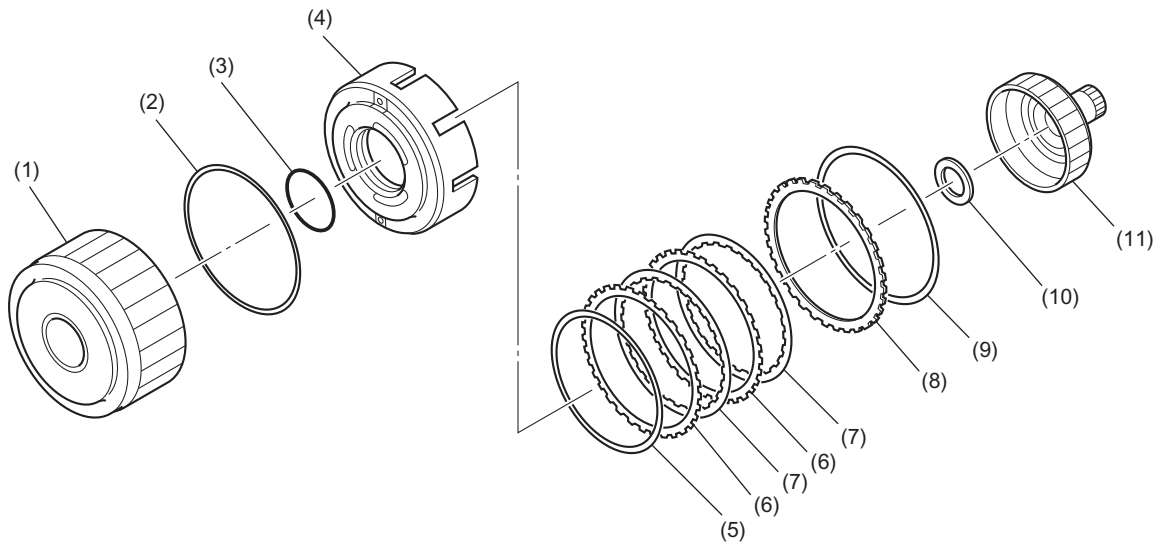

AT-00463

- (1) High clutch drum
- (2) Lip seal
- (3) D-ring
- (4) Reverse clutch piston
- (5) Dish plate
- (6) Driven plate

- (7) Drive plate
- (8) Retaining plate
- (9) Snap ring
- (10) Thrust needle bearing
- (11) High clutch hub

REVERSE CLUTCH

AUTOMATIC TRANSMISSION

B: FUNCTION

1. WHEN REVERSE IS SELECTED

Hydraulic pressure from the control valve is applied to the reverse clutch piston when a shift is made into the reverse. The drive and driven plates are pressed together by this pressure, so that the engine torque from the high clutch drum is transmitted to the front sun gear through the 2-4 brake hub.

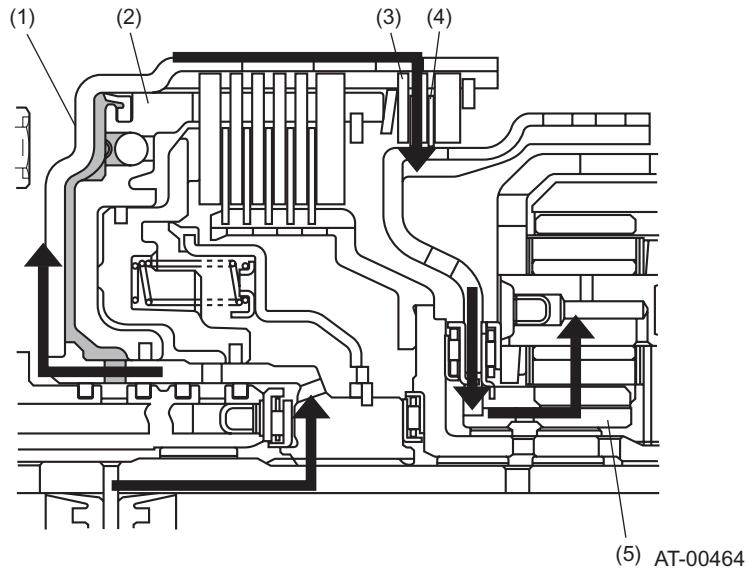

- | | |
|---------------------------|--------------------|
| (1) High clutch drum | (4) Drive plate |
| (2) Reverse clutch piston | (5) Front sun gear |
| (3) Driven plate | |

REVERSE CLUTCH

AUTOMATIC TRANSMISSION

2. WHEN REVERSE IS NOT SELECTED

When the select lever is in any position other than reverse, no pressure is applied to the reverse clutch piston. Hence the drive and driven plates are separated from each other, transmitting no power to any element beyond them.

A check ball is built into the clutch piston. This check ball has a function of releasing the pressure which may build up in the fluid remaining behind the piston by centrifugal force generated by the idly rotating high clutch drum, thereby avoiding a half-engaged state of the clutch.

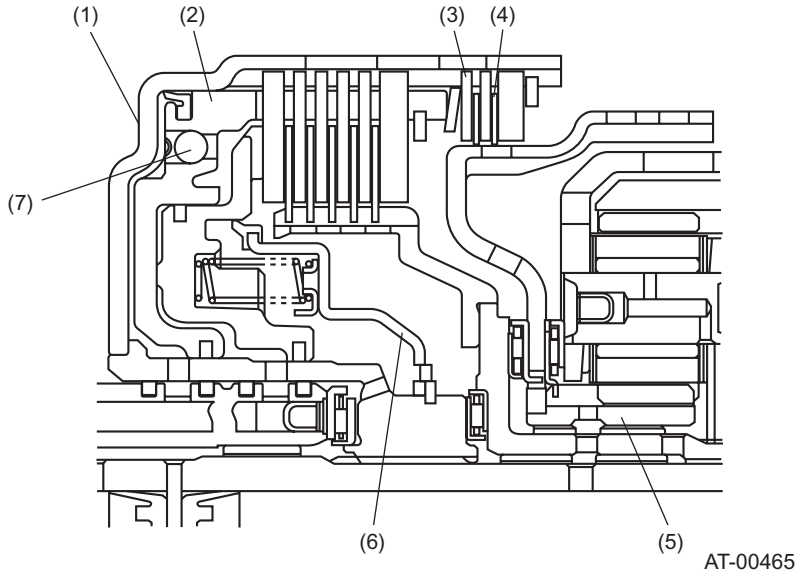

- | | |
|---------------------------|--------------------|
| (1) High clutch drum | (5) Front sun gear |
| (2) Reverse clutch piston | (6) Cover |
| (3) Driven plate | (7) Check ball |
| (4) Drive plate | |

3. High Clutch

When the 3rd or 4th gear is selected, hydraulic pressure is applied to the high clutch from the shift valve and pressure regulator valve. The clutch drive and driven plates are pressed together, thus transmitting the engine power from the input shaft to the front planetary carrier through the high clutch hub.

A cover is placed inside the piston, and the space between the piston and the cover is filled with ATF. When the high clutch is not in engagement, the centrifugal force generated in the ATF inside the cover cancels out the centrifugal force generated in the ATF remaining behind the high clutch piston, thus preventing incomplete disengagement of the clutch.

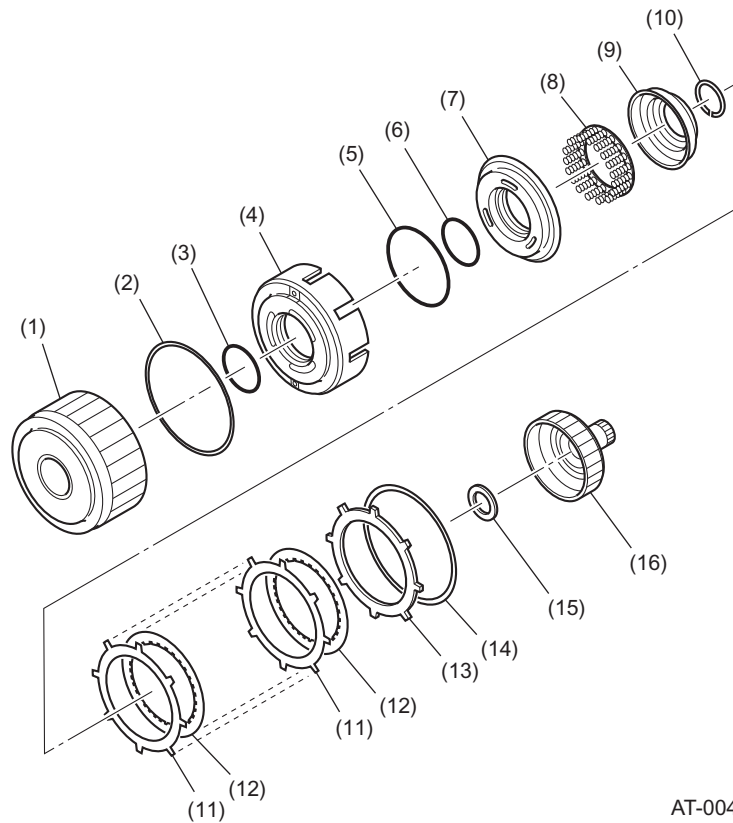

AT-00466

- | | | |
|---------------------------|------------------------|----------------------------|
| (1) High clutch drum | (7) High clutch piston | (13) Retaining plate |
| (2) Lip seal | (8) Return spring | (14) Snap ring |
| (3) D-ring | (9) Cover | (15) Thrust needle bearing |
| (4) Reverse clutch piston | (10) Snap ring | (16) High clutch hub |
| (5) D-ring (outer) | (11) Driven plate | |
| (6) D-ring (inner) | (12) Drive plate | |

2-4 BRAKE

AUTOMATIC TRANSMISSION

4. 2-4 Brake

A: CONSTRUCTION

The 2-4 brake consists of a 2-4 brake piston retainer, 2-4 brake piston, return spring, pressure plate, drive plates, driven plates, and a snap ring that fits in a housing formed in the transmission case.

This brake is engaged by the hydraulic pressure from the control valve and locks the front sun gear when the 2nd or 4th gear is selected.

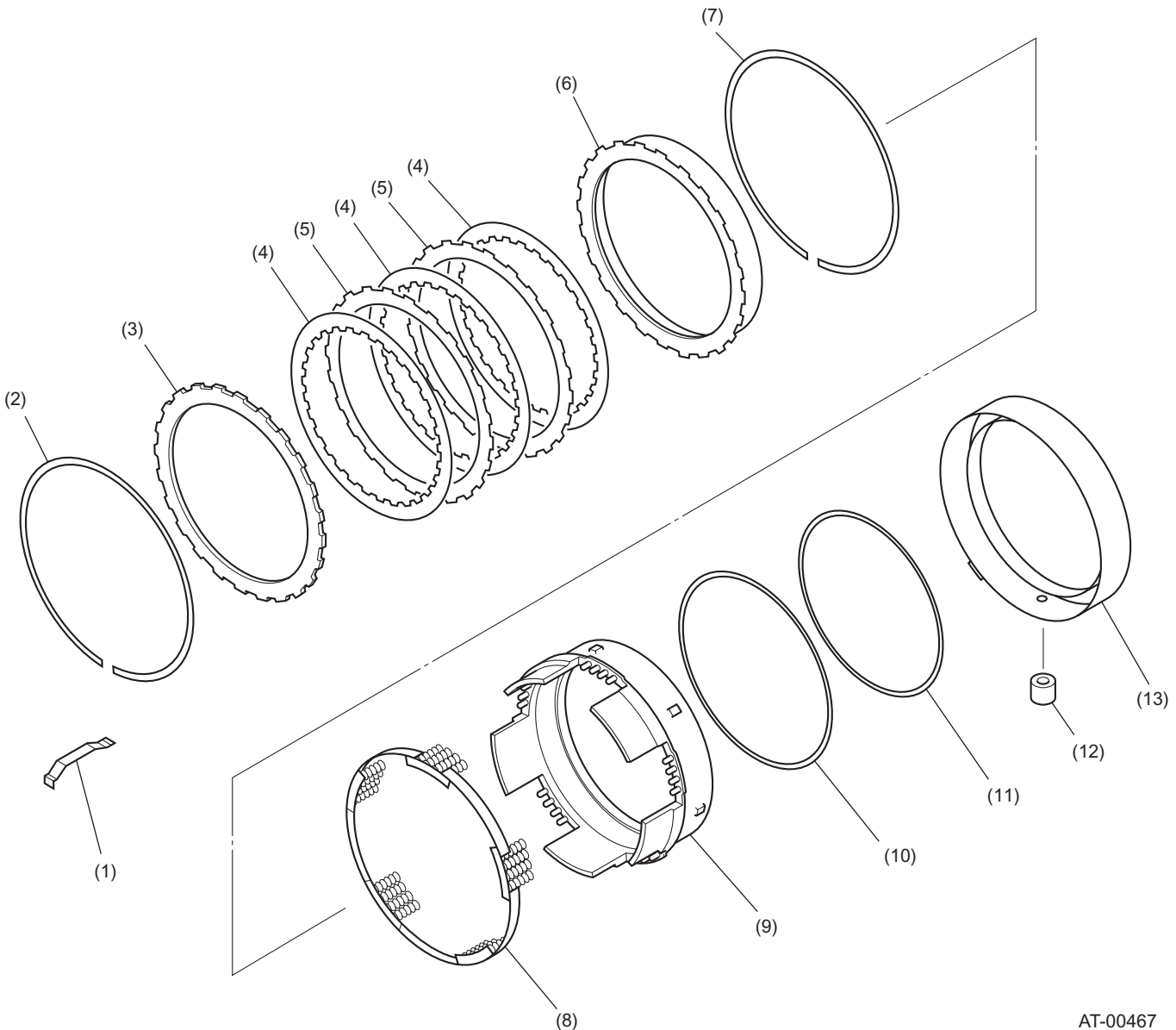

AT-00467

- | | | |
|---------------------|-------------------------|--------------------------------|
| (1) Leaf spring | (6) Pressure rear plate | (10) D-ring |
| (2) Snap ring | (7) Snap ring | (11) D-ring |
| (3) Retaining plate | (8) Return spring | (12) 2-4 brake piston seal |
| (4) Drive plate | (9) 2-4 brake piston | (13) 2-4 brake piston retainer |
| (5) Driven plate | | |

Brought to you by Eris Studios
NOT FOR RESALE

5. Low & Reverse Brake

A: CONSTRUCTION

The low & reverse brake consists of a piston, a dish plate, drive plates, driven plates, a retaining plate and a snap ring that fits in a housing formed in the transmission case.

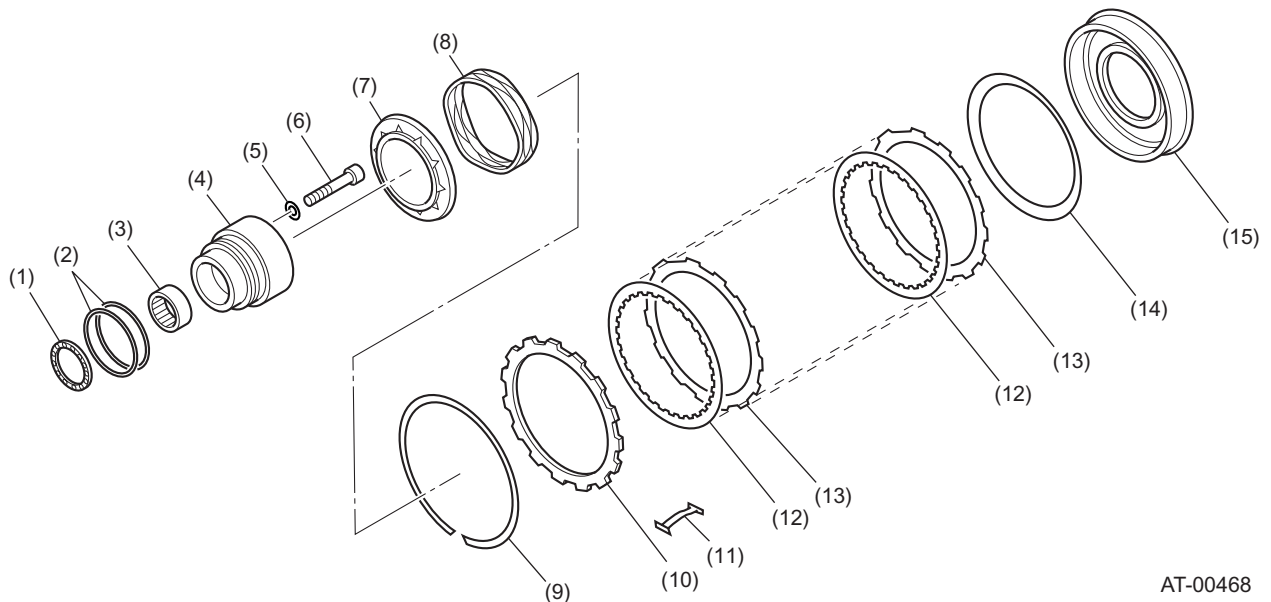

AT-00468

- | | | |
|-------------------------------|----------------------|---------------------------------|
| (1) Thrust bearing | (6) Bolt | (11) Leaf spring |
| (2) Seal ring | (7) Spring retainer | (12) Drive plate |
| (3) Needle bearing | (8) Return spring | (13) Driven plate |
| (4) One-way clutch inner race | (9) Snap ring | (14) Dish plate |
| (5) Washer | (10) Retaining plate | (15) Low & reverse brake piston |

B: FUNCTION

When the 1st gear of manual mode or reverse is selected, the pressure from the control valve is applied to the low & reverse brake piston. The piston then presses the drive and driven plates together and causes the low clutch drum to lock.

Brought to you by Eris Studios
NOT FOR RESALE

6. Low Clutch

A: CONSTRUCTION

The low clutch consists of a drum, piston, return springs, cover, drive plates, driven plates, one-way clutch, and the retaining plate.

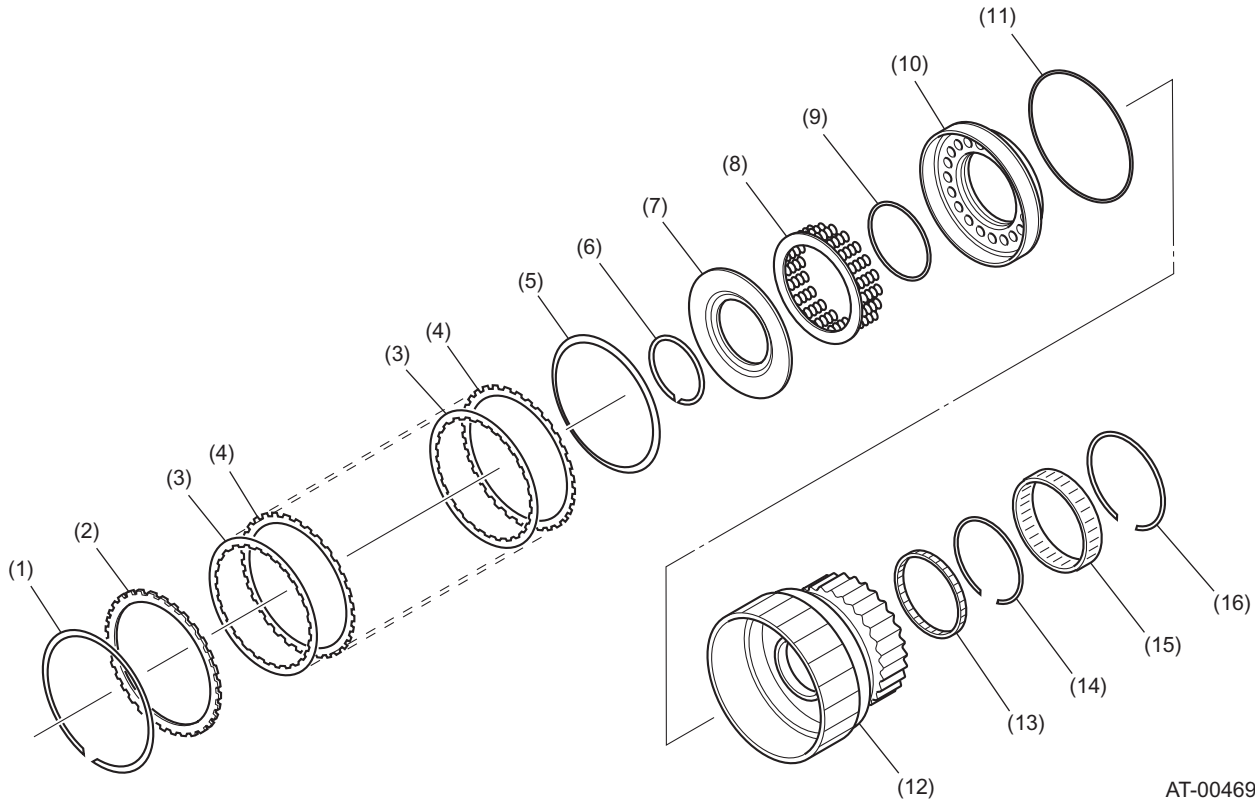

AT-00469

- | | | |
|---------------------|------------------------|---------------------|
| (1) Snap ring | (7) Cover | (13) Needle bearing |
| (2) Retaining plate | (8) Return spring | (14) Snap ring |
| (3) Drive plate | (9) D-ring | (15) One-way clutch |
| (4) Driven plate | (10) Low clutch piston | (16) Snap ring |
| (5) Dish plate | (11) D-ring | |
| (6) Snap ring | (12) Low clutch drum | |

B: FUNCTION

The low clutch operates in the 1st, 2nd and 3rd speed gears.

This clutch engages when hydraulic pressure from the control valve is applied to the low clutch piston, transmitting power through the rear planetary carrier to the reduction drive shaft.

A cover is placed inside the piston, and the space between the piston and the cover is filled with ATF. When the low clutch is not in engagement, the centrifugal force generated in the ATF inside the cover cancels out the centrifugal force generated in the ATF remaining behind the low clutch piston, thus preventing incomplete disengagement of the clutch.

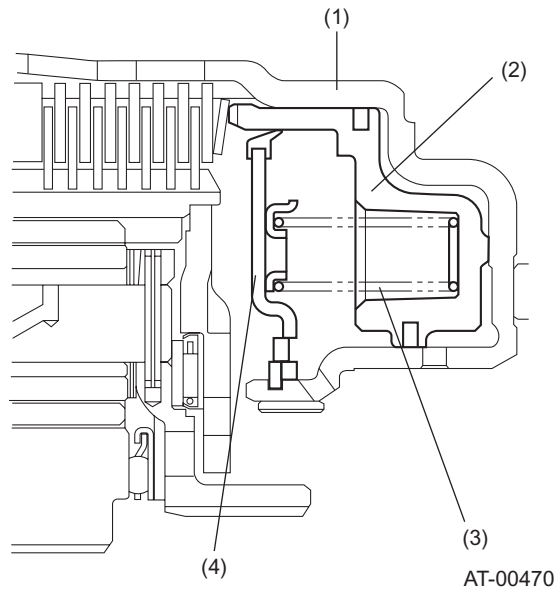

- (1) Low clutch drum
- (2) Low clutch piston

- (3) Return spring
- (4) Cover

REDUCTION GEAR

Brought to you by Eris Studios
NOT FOR RESALE

7. Reduction Gear

A: GENERAL

Engine output is transmitted from the rear planetary carrier to the reduction drive shaft and the reduction drive gear. Power to the front wheels is then transmitted through the reduction driven gear and drive pinion to the front final gears and front wheels. Power to the rear wheels is transmitted sequentially from the transfer clutch hub through the transfer clutch, rear drive shaft, propeller shaft, and rear differential to the rear wheels.

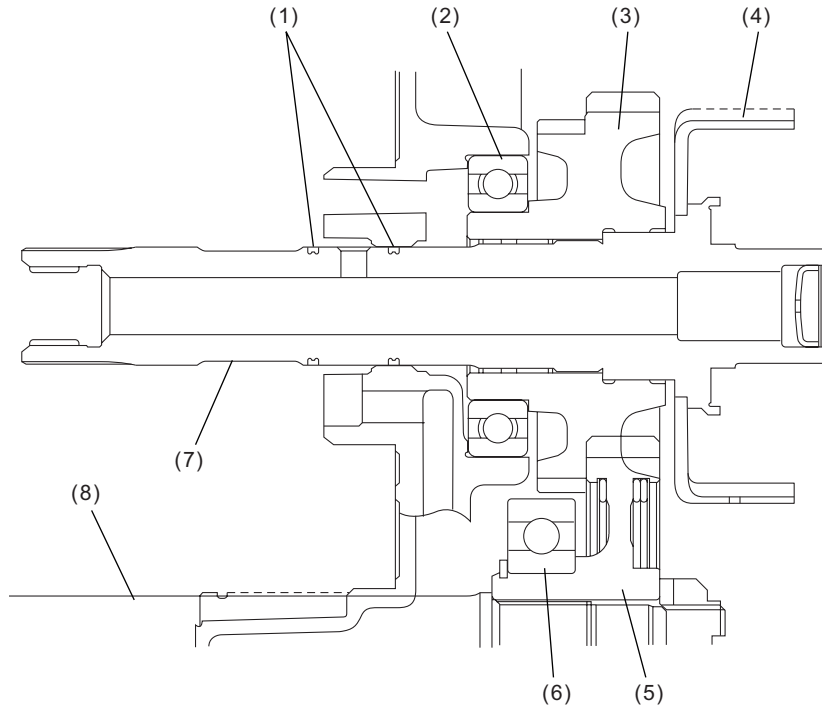

AT-02183

- | | | |
|--------------------------|---------------------------|---------------------------|
| (1) Seal ring | (4) Transfer clutch hub | (7) Reduction drive shaft |
| (2) Ball bearing | (5) Reduction driven gear | (8) Drive pinion shaft |
| (3) Reduction drive gear | (6) Ball bearing | |

8. Control Valve

The hydraulic control system of the automatic transmission consists of an oil pump, valve bodies containing valves, clutches, fluid passages and pipes. The operation of the system is controlled by driver's manual inputs and electrical inputs from the TCM.

A: CONSTRUCTION

The structure of the control valve is simplified by disusing the accumulator and decreasing the number of mechanical valves. This allowed a two-layered body structure, which contributes to minimizing the size and weight. Also, the transfer hydraulic control mechanism is contained in the control valve.

Oil pressure from the duty solenoid for each clutch will be directly applied to the clutch/brake without flowing through an accumulator, therefore the engagement/disengagement control range is widened and the response during gear shift is improved.

Brought to you by Eris Studios
NOT FOR RESALE

9. Gear Train

A: CONSTRUCTION

The gear train consists of two sets of planetary gears, three sets of multi-plate clutches, two sets of multi-plate brakes and one set of one-way clutch.

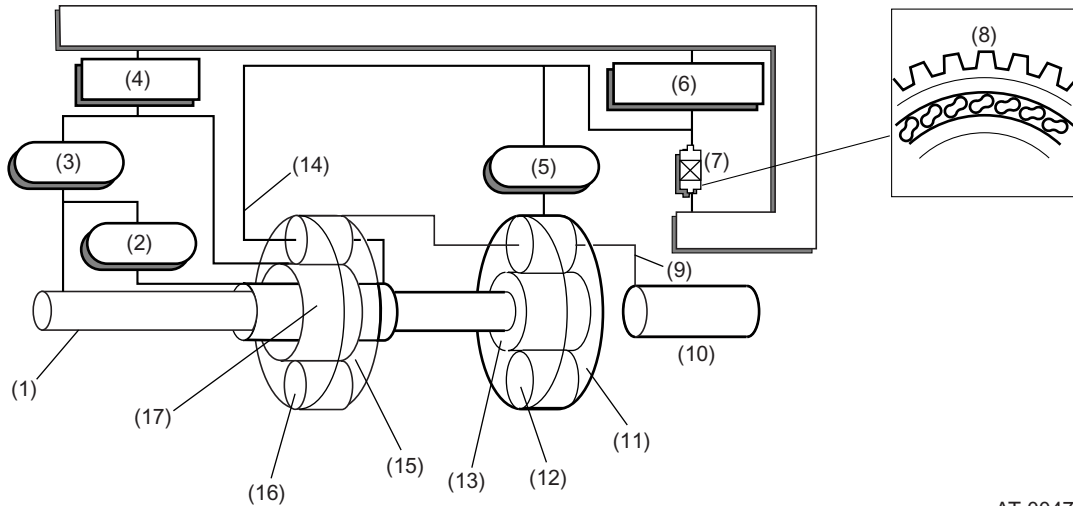

AT-00474

- | | | |
|-------------------------|----------------------------|------------------------------|
| (1) Input shaft | (7) One-way clutch | (13) Rear sun gear |
| (2) High clutch | (8) Free/locked | (14) Front planetary carrier |
| (3) Reverse clutch | (9) Rear planetary carrier | (15) Front internal gear |
| (4) 2-4 brake | (10) Reduction drive shaft | (16) Front pinion gear |
| (5) Low clutch | (11) Rear internal gear | (17) Front sun gear |
| (6) Low & reverse brake | (12) Rear pinion gear | |

Brought to you by Eris Studios
NOT FOR RESALE

B: OPERATION

1. OPERATION TABLE

		Reverse clutch	2-4 brake	High clutch	Low clutch	Low & reverse brake	One-way clutch	
Select lever position	(P)							
	(R)	○				○		
	(N)							
	(D)	1st ↑↓				○		○
		2nd ↑↓		○		○		
		3rd ↑↓			○	○		
		4th ↑↓		○	○			
	Manual mode	1st ↑↓ Above preset speed				○	○	
		1st ↓ Below preset speed				○		○
		2nd ↑↓		○		○		
		3rd ↑↓			○	○		
		4th ↑↓		○	○			

AT-02305

GEAR TRAIN

AUTOMATIC TRANSMISSION

2. N RANGE

Since the rear sun gear and the high clutch drum are in mesh with the input shaft, they rotate together with the input shaft.

The high clutch drum does not transmit the torque to the planetary unit since the reverse clutch and the high clutch are not engaged.

The torque of the rear sun gear is transmitted to the rear internal gear through the pinion gear.

However, the torque of the rear sun gear is not transmitted to the rear planetary carrier since the low clutch is disengaged and, therefore, the rear internal gear is freewheeling.





As a result, the torque of the input shaft is not transmitted to the reduction drive shaft.

Operating condition of components	Power flow (in acceleration)
All clutches and brakes : disengaged	<pre>graph TD; A[Input shaft] --> B[Rear sun gear]; B --> C[Rear pinion gear]; C --> D[Rear internal gear]; D --> E[Low clutch (free)];</pre> <p style="text-align: right;">AT-00476</p>

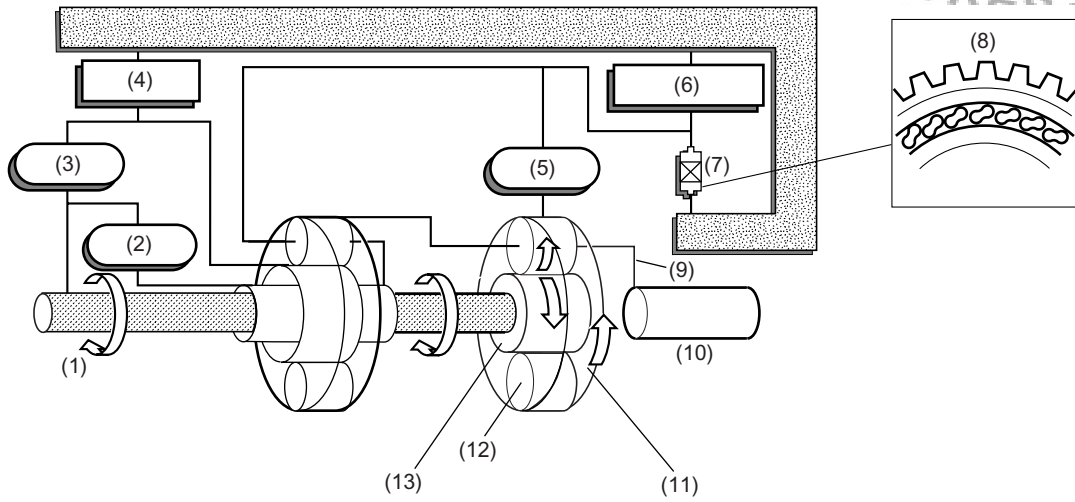
GEAR TRAIN

AUTOMATIC TRANSMISSION



-  : (14)
-  : (15)
-  : (16)
-  : (17)

AT-00477

- | | | |
|-------------------------|----------------------------|---|
| (1) Input shaft | (7) One-way clutch | (13) Rear sun gear |
| (2) High clutch | (8) No effect | (14) Input |
| (3) Reverse clutch | (9) Rear planetary carrier | (15) Output |
| (4) 2-4 brake | (10) Reduction drive shaft | (16) Locked |
| (5) Low clutch | (11) Rear internal gear | (17) Planetary gear components involved in power transmission |
| (6) Low & reverse brake | (12) Rear pinion gear | |

GEAR TRAIN

AUTOMATIC TRANSMISSION

3. P RANGE





All the clutches and brakes are free, just as in the N range. The parking pawl engages with the parking gear, which forms an integral part of the reduction drive gear, preventing the gear from rotating.

Operating condition of components	Power flow (in acceleration)
All clutches and brakes: disengaged	<pre>graph TD; A[Input shaft] --> B[Rear sun gear]; B --> C[Rear pinion gear]; C --> D[Rear internal gear]; D --> E[Low clutch (free)];</pre> <p>AT-00476</p>

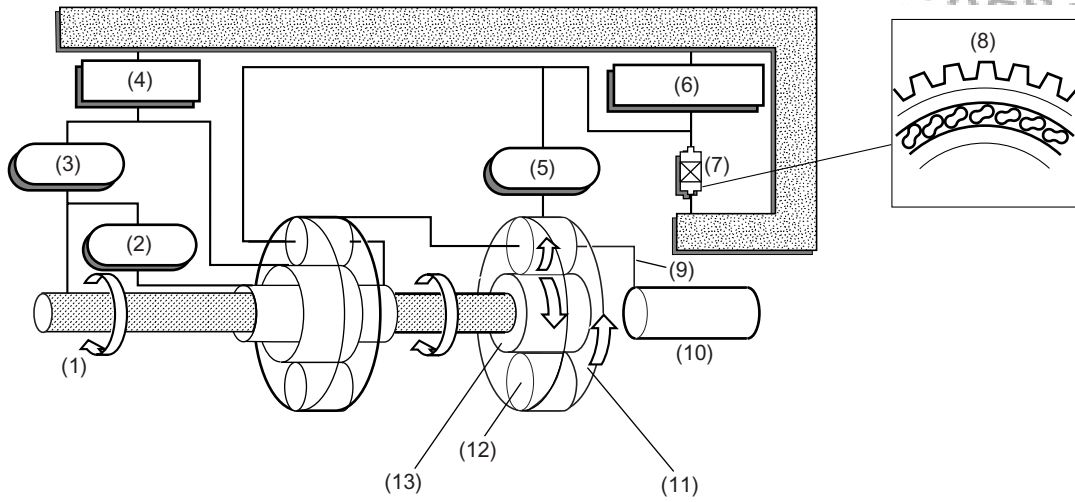
GEAR TRAIN

AUTOMATIC TRANSMISSION



-  : (14)
-  : (15)
-  : (16)
-  : (17)

AT-00477

- | | | |
|-------------------------|----------------------------|---|
| (1) Input shaft | (7) One-way clutch | (13) Rear sun gear |
| (2) High clutch | (8) No effect | (14) Input |
| (3) Reverse clutch | (9) Rear planetary carrier | (15) Output |
| (4) 2-4 brake | (10) Reduction drive shaft | (16) Locked |
| (5) Low clutch | (11) Rear internal gear | (17) Planetary gear components involved in power transmission |
| (6) Low & reverse brake | (12) Rear pinion gear | |

GEAR TRAIN

AUTOMATIC TRANSMISSION

4. 1st GEAR OF D RANGE OR MANUAL MODE (BELOW SET SPEED) (D_1)

When the 1st gear is selected in the D range or in manual mode (below set speed), only the low clutch is engaged. In this state, the rear internal gear attempts to rotate counterclockwise but it is impossible by the action of the one-way clutch which locks the internal gear to the transmission case. As a result, rotation of the rear sun gear causes the pinion gears to rotate around the sun gear. This causes the planetary carrier to rotate. In this way, rotation of the input shaft is transmitted to the reduction drive shaft, after being subjected to speed reduction by the planetary gear train.

On the other hand, the rear internal gear rotates clockwise if the reverse driving force is applied to it by the reduction drive shaft during coasting. This clockwise rotation of the internal gear causes the one-way clutch to freewheel. Since the power path between the reduction drive shaft and the input shaft is lost as a result, no engine braking effect is available.

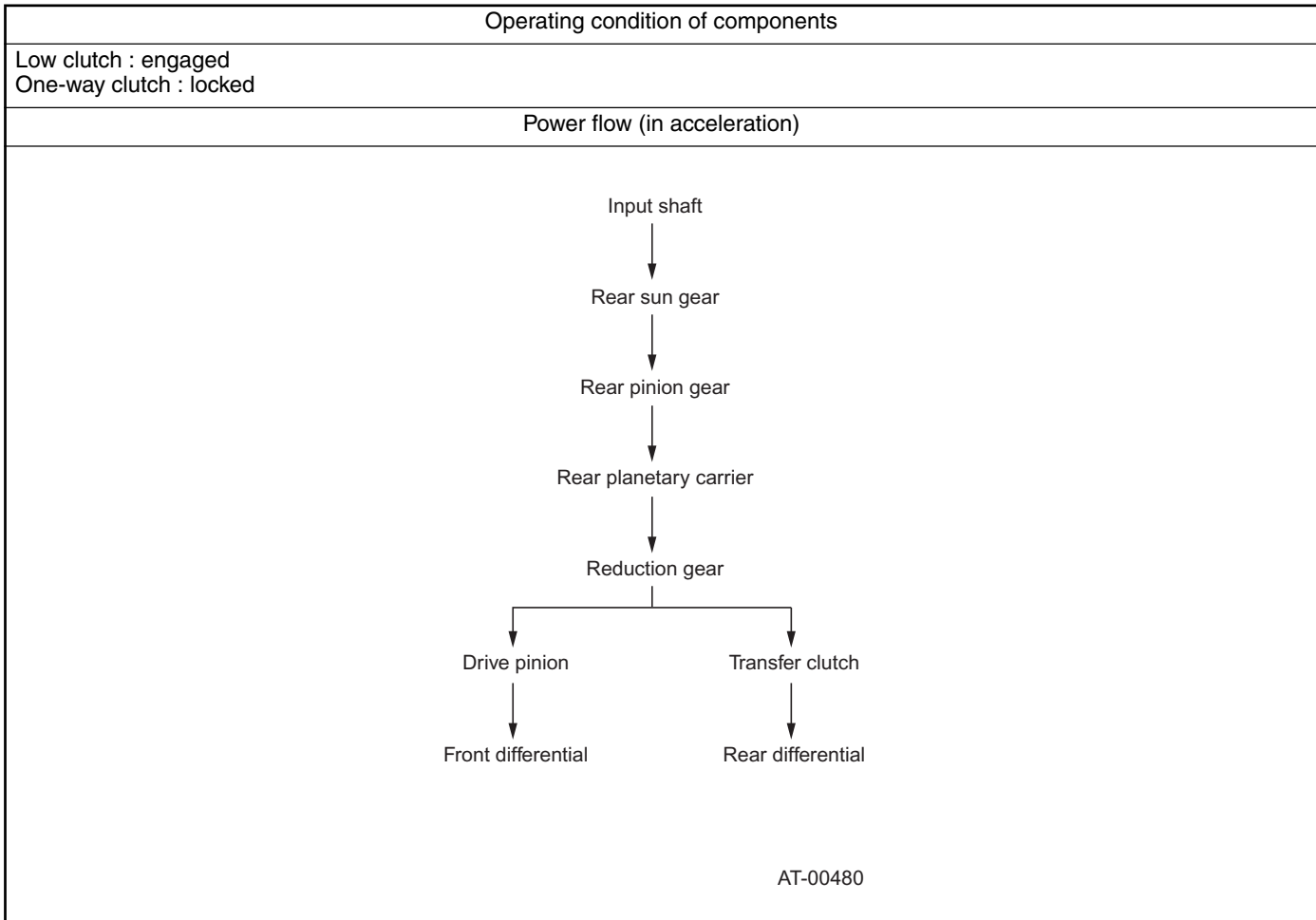

GEAR TRAIN

AUTOMATIC TRANSMISSION

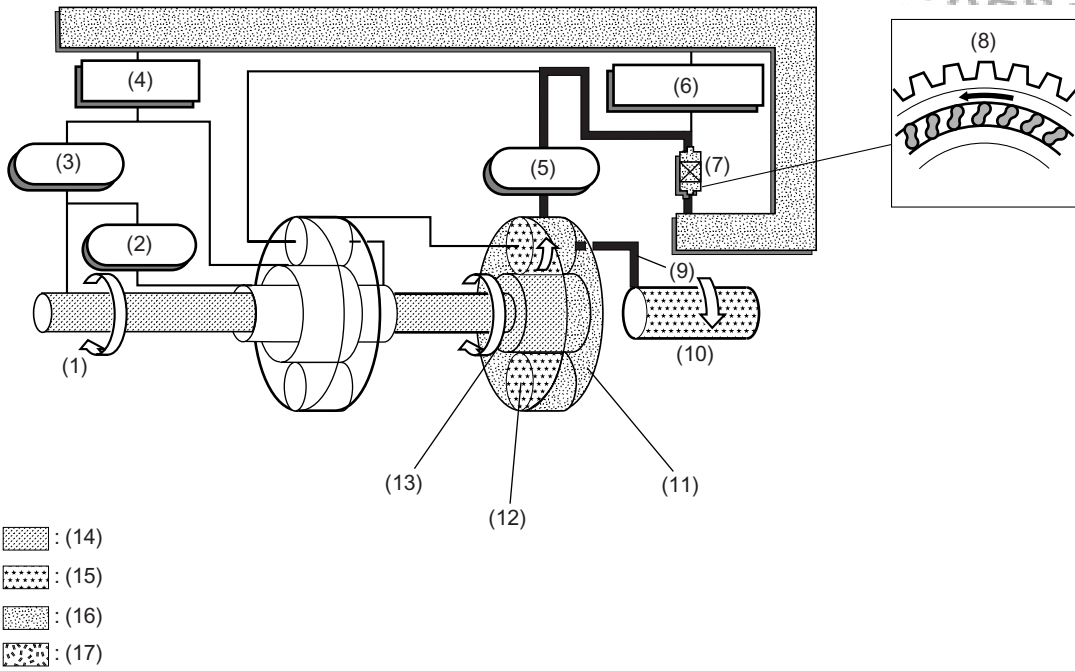

AT-00481

- | | | |
|-------------------------|----------------------------|---|
| (1) Input shaft | (7) One-way clutch | (13) Rear sun gear |
| (2) High clutch | (8) Locked | (14) Input |
| (3) Reverse clutch | (9) Rear planetary carrier | (15) Output |
| (4) 2-4 brake | (10) Reduction drive shaft | (16) Locked |
| (5) Low clutch | (11) Rear pinion gear | (17) Planetary gear components involved in power transmission |
| (6) Low & reverse brake | (12) Rear pinion gear | |

GEAR TRAIN

AUTOMATIC TRANSMISSION

5. 2nd GEAR

When the 2nd gear is selected, the 2-4 brake and the low clutch are engaged. The front sun gear is now locked to the transmission case due to engagement of the 2-4 brake. In this state, the torque of the rear sun gear is transmitted to the rear internal gear through the path of the front internal gear, front pinion gears, low clutch drum and low clutch. At this time, the one-way clutch is freewheeling since the low clutch drum is rotating clockwise.

In this power flow configuration, the rear pinion gears are rotated by the rear internal gear at a speed faster than that available from the configuration for the 1st gear, so the rotation speed of the reduction drive shaft is higher than that of the 1st gear.



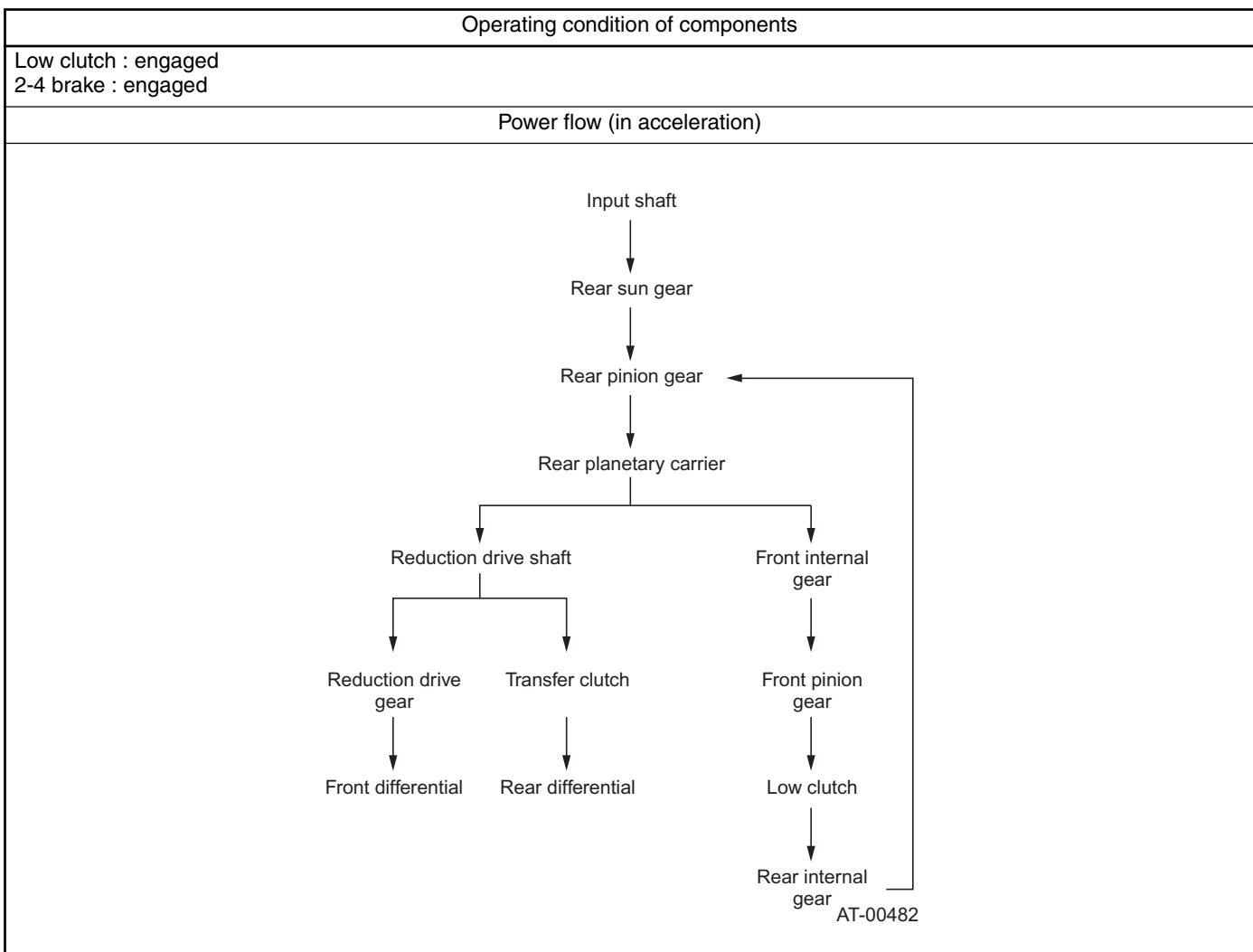

Since the drive power is transmitted without passing through the one-way clutch in the 2nd gear, the backward driving force from the wheels is transmitted through the reduction drive shaft to the input shaft; this makes the engine braking effect available.

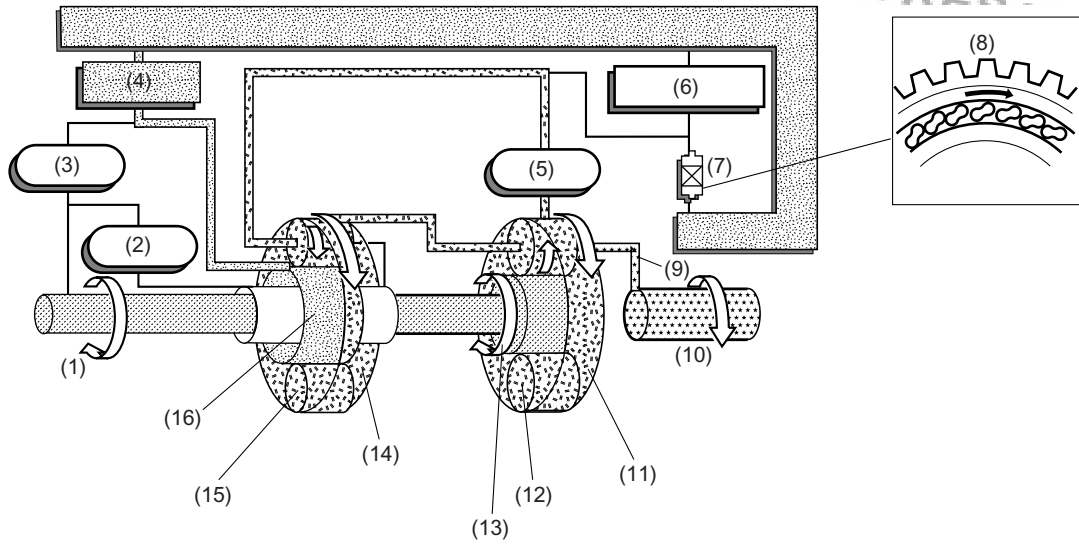

GEAR TRAIN

AUTOMATIC TRANSMISSION



-  : (17)
-  : (18)
-  : (19)
-  : (20)

AT-00483

- | | | |
|----------------------------|----------------------------|---|
| (1) Input shaft | (8) Free | (15) Front pinion gear |
| (2) High clutch | (9) Rear planetary carrier | (16) Front sun gear |
| (3) Reverse clutch | (10) Reduction drive shaft | (17) Input |
| (4) 2-4 brake | (11) Rear internal gear | (18) Output |
| (5) Low clutch | (12) Rear pinion gear | (19) Locked |
| (6) Low and reverse clutch | (13) Rear sun gear | (20) Planetary gear components involved in power transmission |
| (7) One-way clutch | (14) Front internal gear | |

6. 3rd GEAR

When the 3rd gear is selected, the low clutch and the high clutch are engaged. The engaged high clutch rotates through its drum the front planetary carrier, and rotation of the carrier is transmitted to the rear internal gear through the engaged low clutch. In this power flow configuration, the rear sun gear and the rear internal gear rotate at the same speed since the rear pinion gears are solid on their axes and the whole planetary gear train rotates as a unit at the same speed as its sun gear. As a result, the input shaft and the reduction drive shaft rotate at the same speed.

In the 3rd gear, the one-way clutch is freewheeling because the low clutch is rotating clockwise. Since the drive power is transmitted without passing through the one-way clutch, the backward driving force from the wheels is transmitted through the reduction drive shaft to the input shaft; this makes the engine braking effect available.

GEAR TRAIN

AUTOMATIC TRANSMISSION

Operating condition of components

High clutch : engaged
Low clutch : engaged

Power flow (in acceleration)

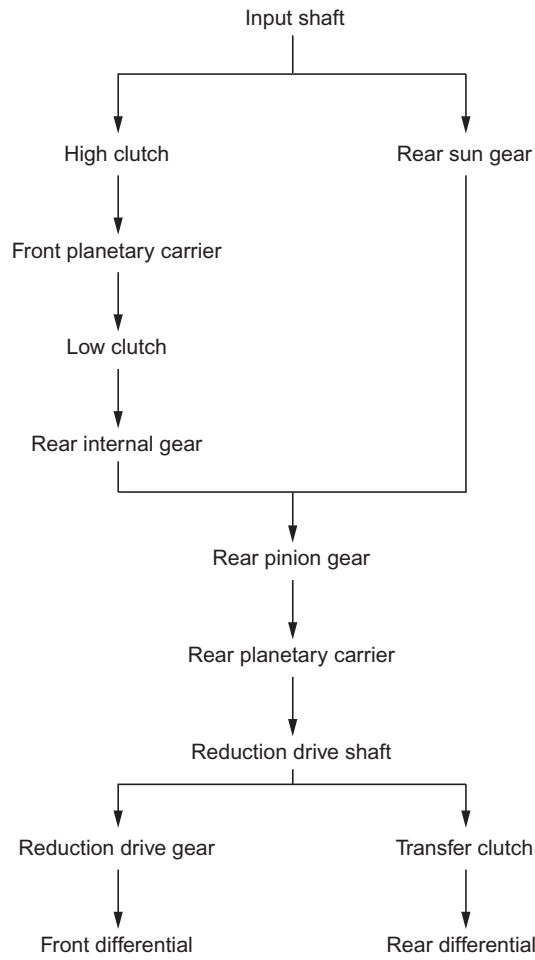

AT-00484

GEAR TRAIN

Brought to you by Eris Studios
NOT FOR RESALE

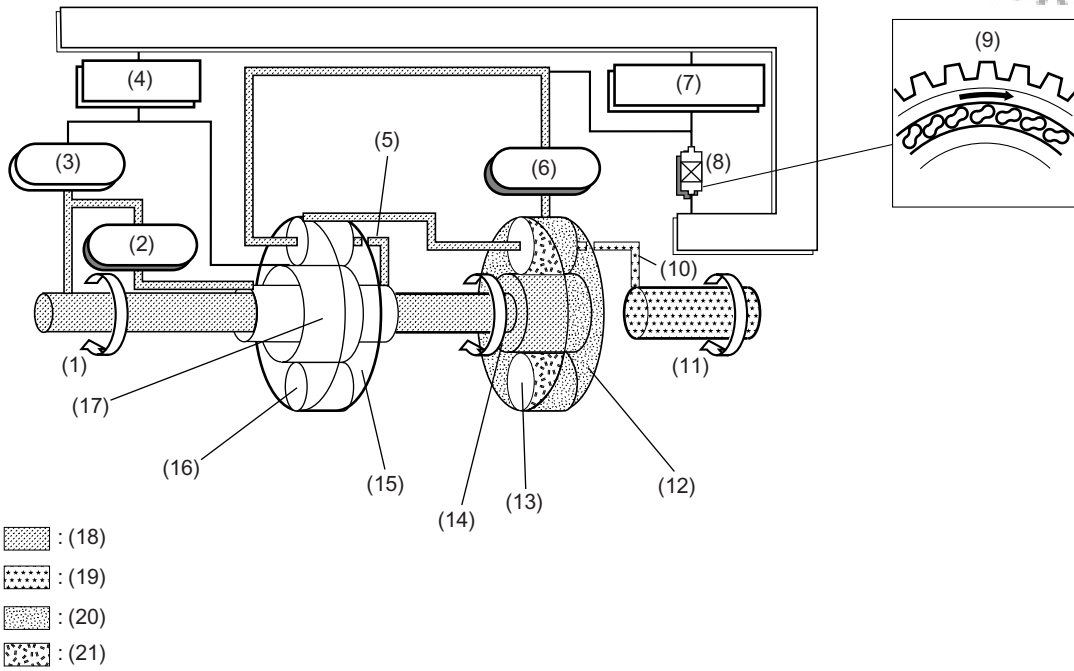

AT-00485

- | | | |
|-----------------------------|-----------------------------|---|
| (1) Input shaft | (8) One-way clutch | (15) Front internal gear |
| (2) High clutch | (9) Free | (16) Front pinion gear |
| (3) Reverse clutch | (10) Rear planetary carrier | (17) Front sun gear |
| (4) 2-4 brake | (11) Reduction drive shaft | (18) Input |
| (5) Front planetary carrier | (12) Rear internal gear | (19) Output |
| (6) Low clutch | (13) Rear pinion gear | (20) Locked |
| (7) Low & reverse brake | (14) Rear sun gear | (21) Planetary gear components involved in power transmission |

Brought to you by Eris Studios
NOT FOR RESALE

MEMO

GEAR TRAIN

AUTOMATIC TRANSMISSION

7. 4th GEAR

When the 4th gear is selected, the high clutch and the 2-4 brake are engaged. The engaged high clutch causes the front planetary carrier to rotate, whereas the engaged 2-4 brake causes the front sun gear to be locked to the transmission case.

The front planetary carrier rotates at the same speed as the input shaft. The rotation of the front planetary carrier causes the front pinion gears to revolve around the stationary front sun gear, which causes the front internal gear to rotate faster than the input shaft.

As a result, the reduction drive shaft is driven at a higher speed than the input shaft.



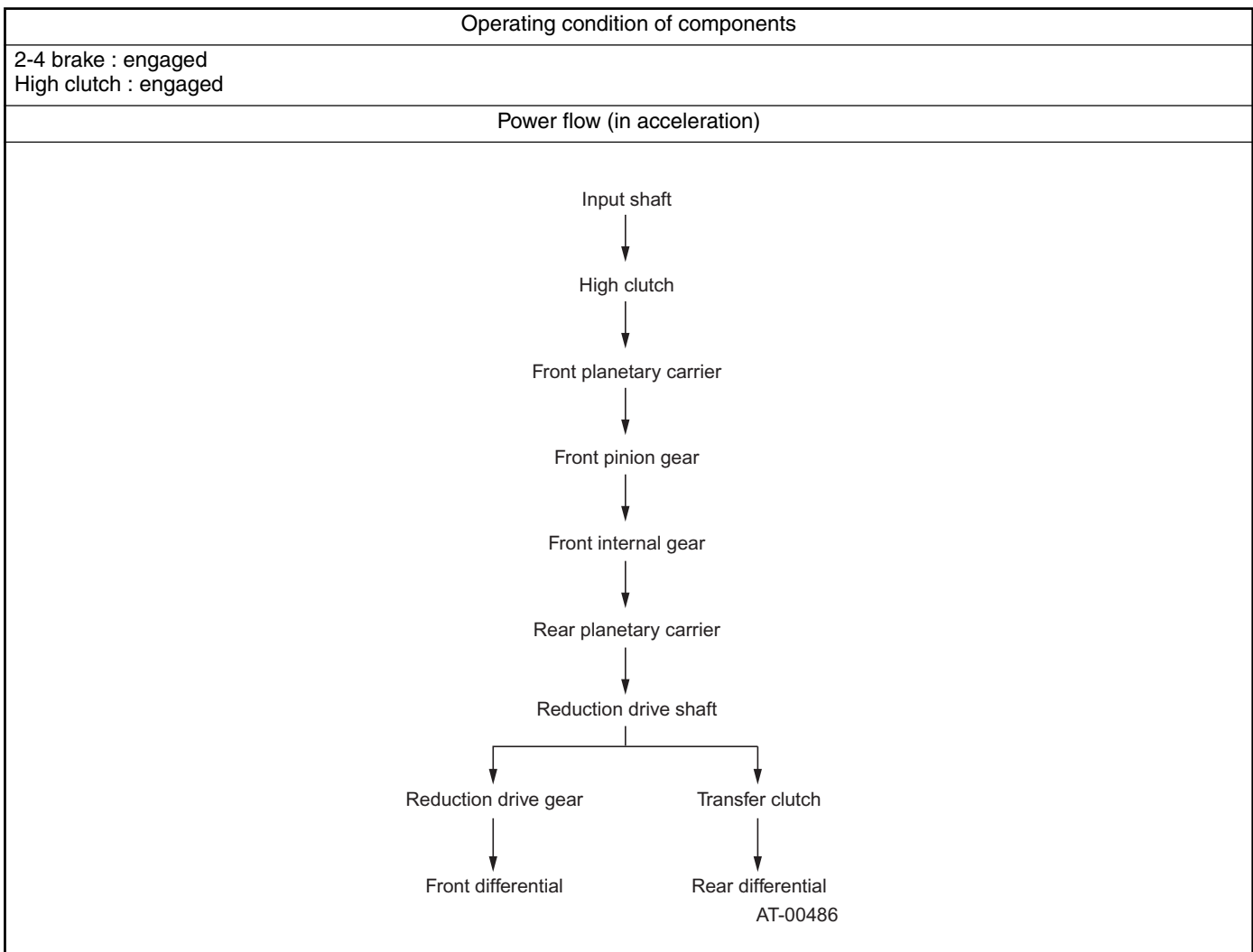

In the 4th gear, the one-way clutch is freewheeling because the low clutch is rotating clockwise. Since the drive power is transmitted without passing through the one-way clutch, the backward driving force from the wheels is transmitted through the reduction drive shaft to the input shaft; this makes the engine braking effect available.

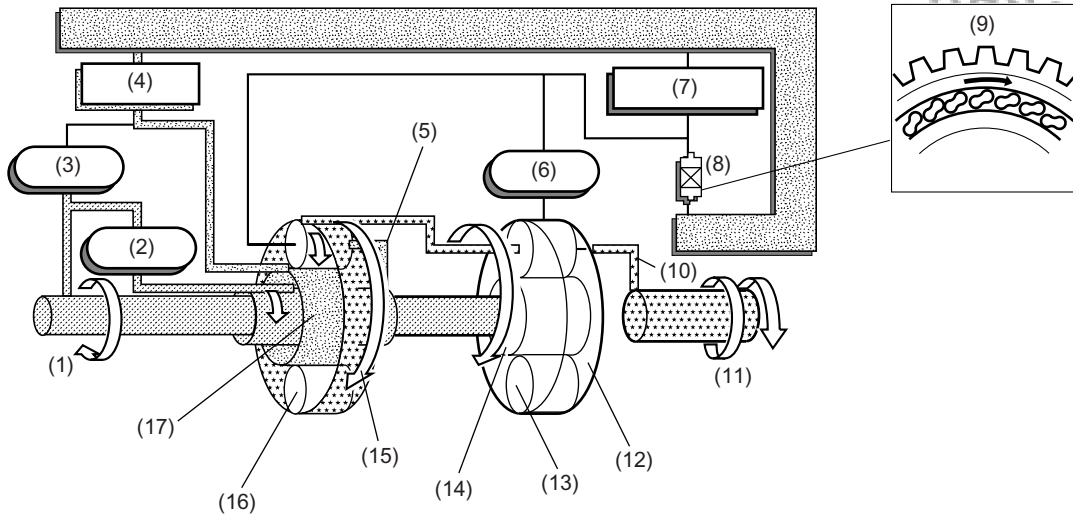

GEAR TRAIN

AUTOMATIC TRANSMISSION



-  : (18)
-  : (19)
-  : (20)
-  : (21)

AT-00487

- | | | |
|-----------------------------|-----------------------------|---|
| (1) Input shaft | (8) One-way clutch | (15) Front internal gear |
| (2) High clutch | (9) Free | (16) Front pinion gear |
| (3) Reverse clutch | (10) Rear planetary carrier | (17) Front sun gear |
| (4) 2-4 brake | (11) Reduction drive shaft | (18) Input |
| (5) Front planetary carrier | (12) Rear internal gear | (19) Output |
| (6) Low clutch | (13) Rear pinion gear | (20) Locked |
| (7) Low & reverse brake | (14) Rear sun gear | (21) Planetary gear components involved in power transmission |

GEAR TRAIN

AUTOMATIC TRANSMISSION

8. 1st SPEED GEAR OF MANUAL MODE (OVER SET SPEED)

When the 1st gear is selected in manual mode (over set speed), both the low clutch and the low & reverse brake are engaged. Although the power flow configuration is the same as that with the 1st gear in the D range, the one-way clutch produces no freewheeling effect because the low & reverse brake is locking the rear internal gear always to the transmission case.

During coasting, therefore, the backward driving force from the wheels is transmitted through the reduction drive gear to the input shaft. This means, unlike the 1st gear in D range, that the engine braking effect is available in this range.

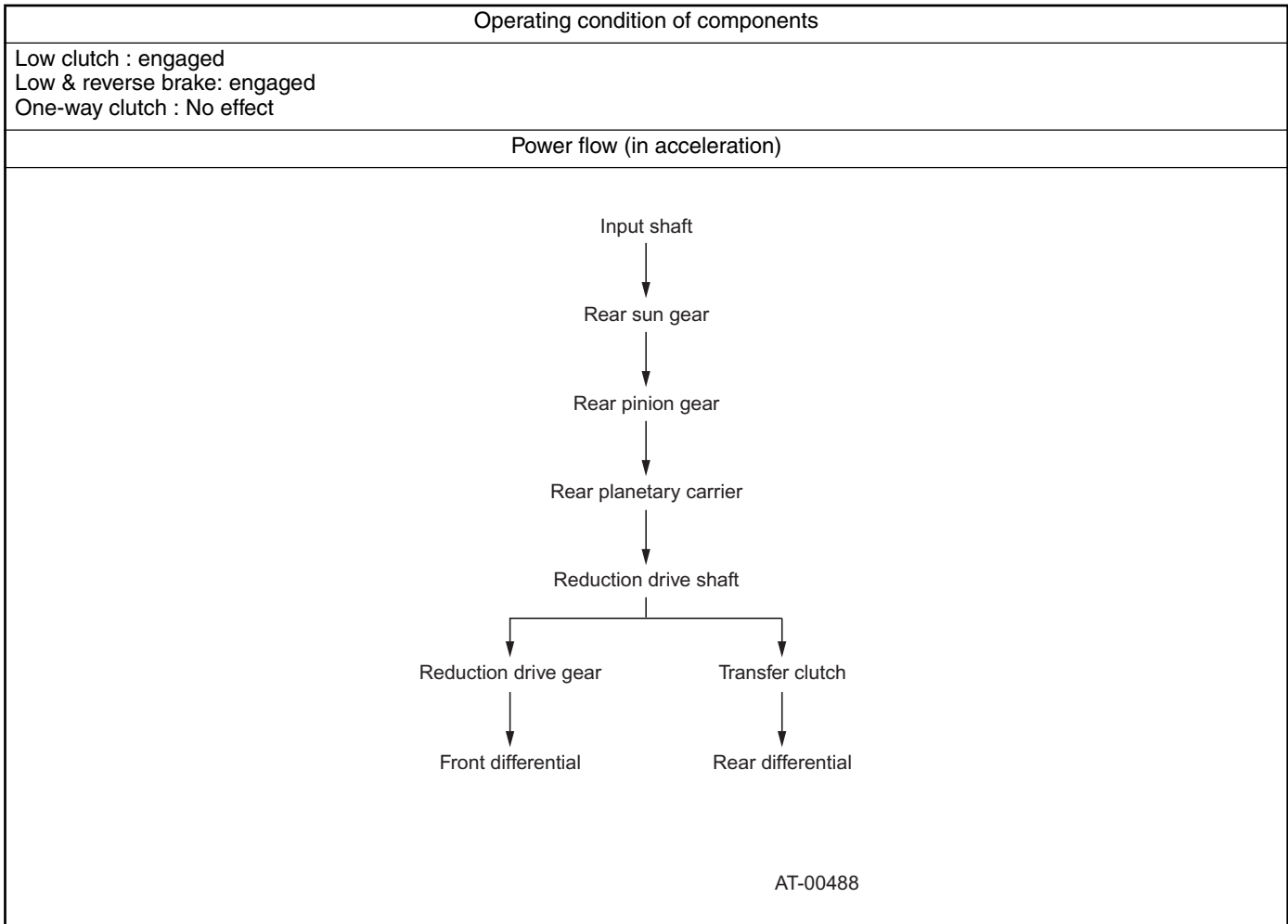

GEAR TRAIN

AUTOMATIC TRANSMISSION

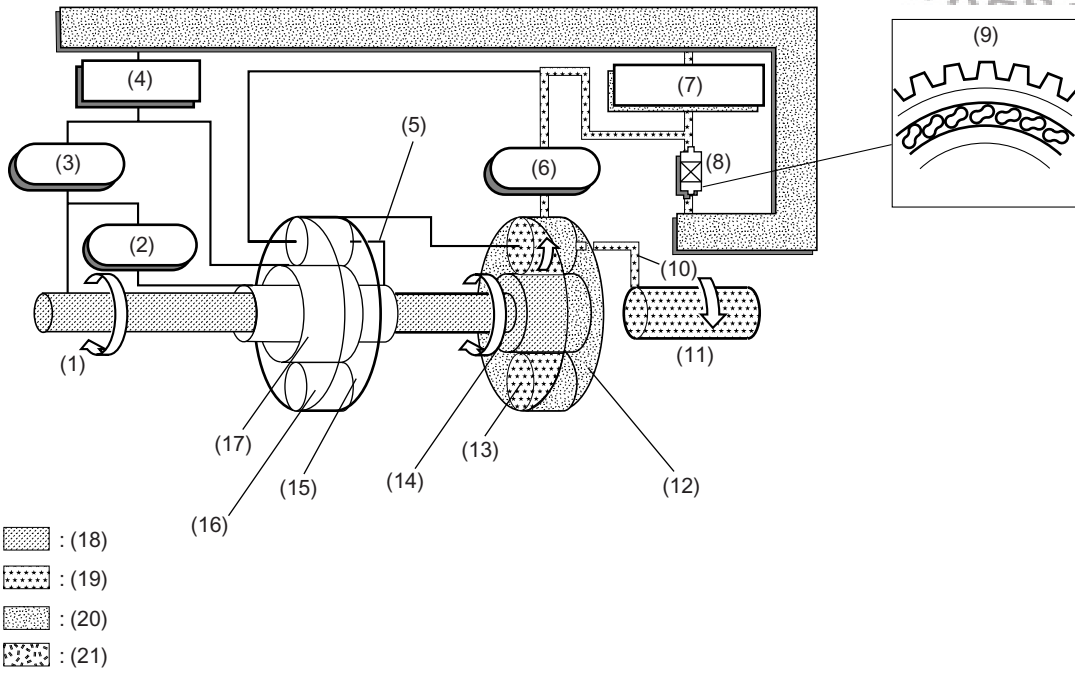

AT-00489

- | | | |
|-----------------------------|-----------------------------|---|
| (1) Input shaft | (8) One-way clutch | (15) Front internal gear |
| (2) High clutch | (9) No effect | (16) Front pinion gear |
| (3) Reverse clutch | (10) Rear planetary carrier | (17) Front sun gear |
| (4) 2-4 brake | (11) Reduction drive shaft | (18) Input |
| (5) Front planetary carrier | (12) Rear internal gear | (19) Output |
| (6) Low clutch | (13) Rear pinion gear | (20) Locked |
| (7) Low & reverse brake | (14) Rear sun gear | (21) Planetary gear components involved in power transmission |

GEAR TRAIN

AUTOMATIC TRANSMISSION

9. R RANGE

When the select lever is placed in the R position, the reverse clutch and the low & reverse brake are engaged. The reverse clutch allows the input shaft torque to be transmitted to the front sun gear, while the low & reverse brake allows the low clutch drum to be interlocked with the transmission case.

The rotation of the front sun gear causes the front pinion gear to rotate in the opposite direction and therefore the front internal gear rotates in the same direction.

At this time, the rotation speed transmitted to the front internal gear is reduced through gearing between the front sun gear and the front pinion gears.

The one-way clutch produces no freewheeling effect because the low & reverse brake is in engagement.



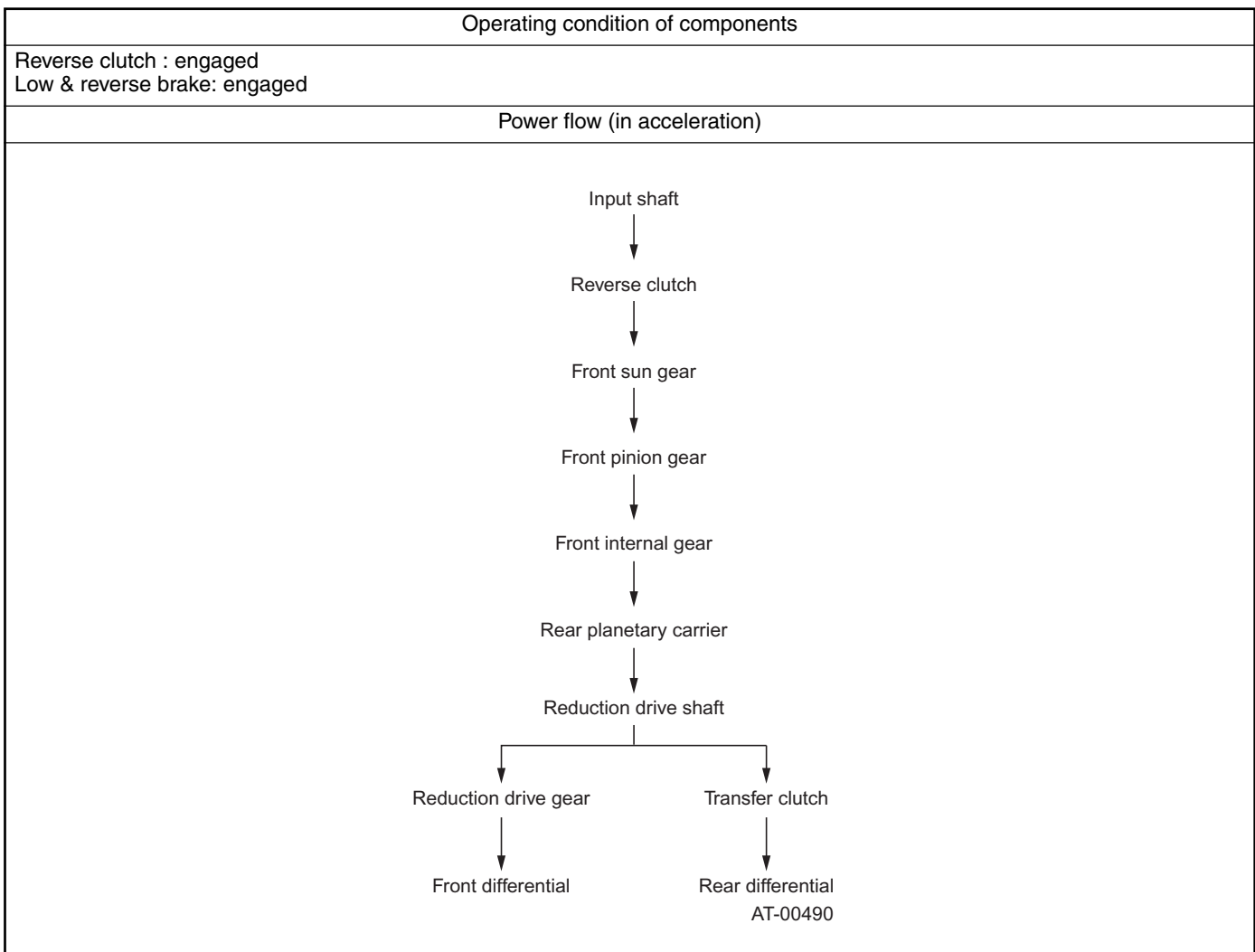

In this range, since the power transmission is made without passing through the one-way clutch, the driving force from the wheels is transmitted through the reduction drive shaft to the input shaft; this makes the engine braking effect available.

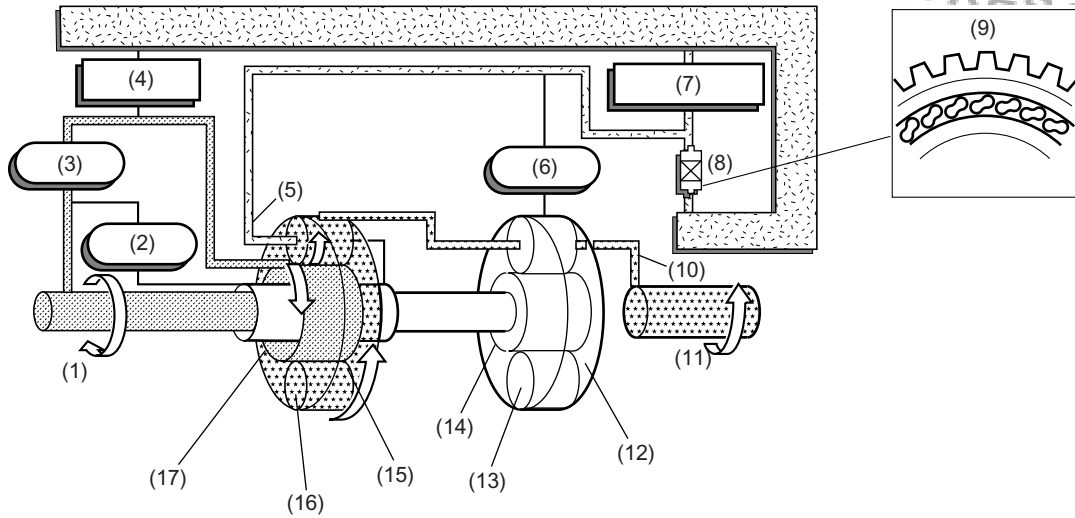

GEAR TRAIN

AUTOMATIC TRANSMISSION



-  : (18)
-  : (19)
-  : (20)
-  : (21)

AT-00491

- | | | |
|-----------------------------|-----------------------------|---|
| (1) Input shaft | (8) One-way clutch | (15) Front internal gear |
| (2) High clutch | (9) No effect | (16) Front pinion gear |
| (3) Reverse clutch | (10) Rear planetary carrier | (17) Front sun gear |
| (4) 2-4 brake | (11) Reduction drive shaft | (18) Input |
| (5) Front planetary carrier | (12) Rear internal gear | (19) Output |
| (6) Low clutch | (13) Rear pinion gear | (20) Locked |
| (7) Low & reverse brake | (14) Rear sun gear | (21) Planetary gear components involved in power transmission |

Brought to you by Eris Studios
NOT FOR RESALE

10.AWD Transfer System

A: GENERAL

This all-wheel-drive (AWD) transfer system uses a hydraulic multi-plate type clutch. The clutch is controlled by the TCM through a control valve.

The TCM has in its memory a set of duty ratio data, each defining at what ratio the transfer clutch should transmit the torque for a particular driving condition. Based on the driving condition information it receives from the corresponding sensors (engine torque, vehicle speed, throttle opening, gear range, slip of wheels, etc.), the TCM selects an appropriate duty ratio from the memory and uses it to control the solenoid valve. The solenoid valve then regulates the pilot pressure of the transfer control valve, which creates the pressure to the clutch from the line pressure. The clutch is engaged to a degree determined by the transfer clutch pressure thus created. Through this process, the torque from the engine is distributed to the rear wheels optimally according to driving conditions.

B: CONSTRUCTION

The transfer clutch drum and rear drive shaft are joined to each other by welding. The rear drive shaft is provided with oil passages for transfer clutch control.

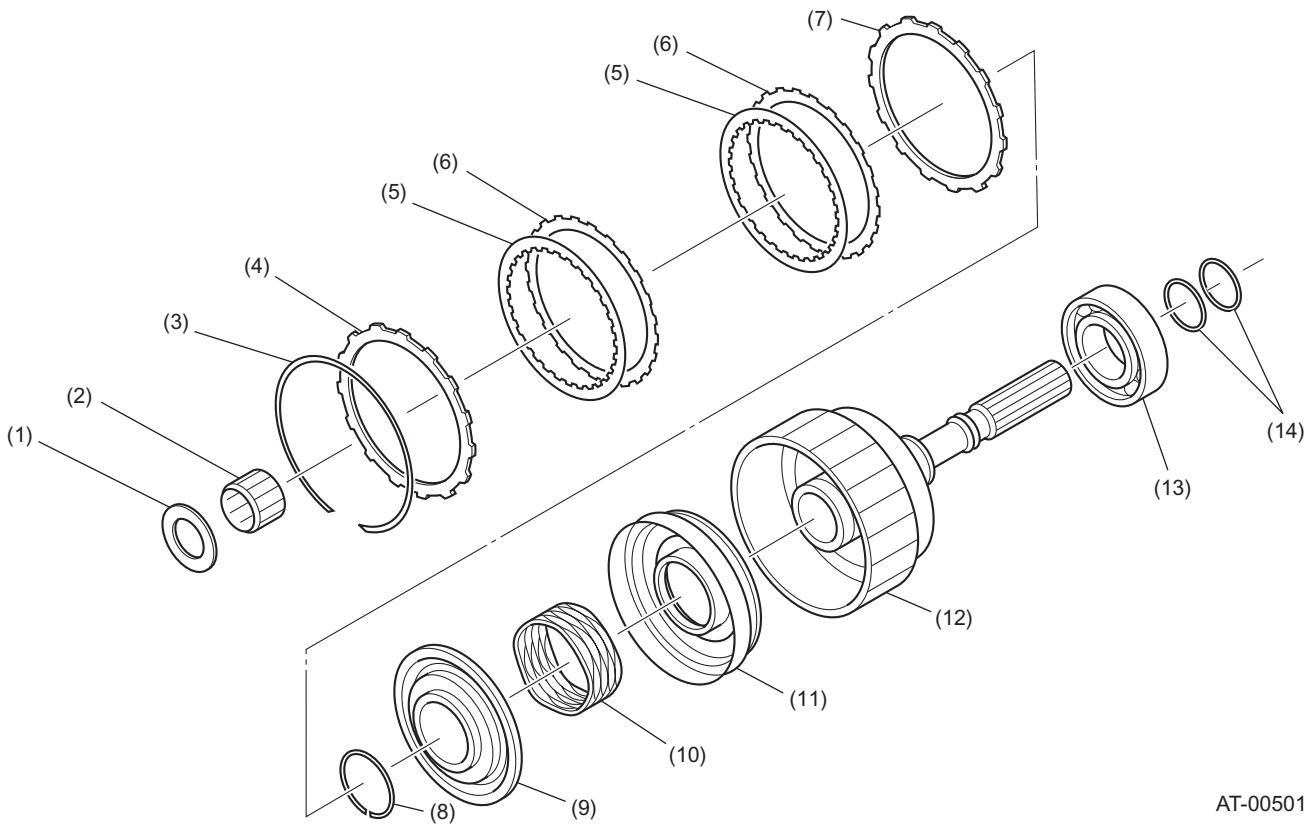

AT-00501

- | | | |
|--------------------|--------------------------|-----------------------------|
| (1) Thrust bearing | (6) Driven plate | (11) Transfer clutch piston |
| (2) Needle bearing | (7) Pressure plate | (12) Rear drive shaft |
| (3) Snap ring | (8) Snap ring | (13) Ball bearing |
| (4) Pressure plate | (9) Transfer piston seal | (14) Seal ring |
| (5) Drive plate | (10) Return spring | |

11. Electro-hydraulic Control System

A: GENERAL

The electro-hydraulic control system for the transmission and transfer consists of various sensors and switches, a transmission control module (TCM) and the control valves including solenoid valves. The system controls the automatic transmission operation, including gear shifting, lockup clutch operation, line pressure, pattern selection (NORMAL and SPORTS), and gear-shift timing. It also controls the operation of the transfer clutch. The TCM determines the vehicle's operating conditions from various input signals and controls a total of seven solenoids (line pressure linear solenoid, lockup duty solenoid, 2-4 brake duty solenoid, low clutch duty solenoid, high clutch duty solenoid, low & reverse duty solenoid, and transfer duty solenoid) by sending appropriate signals to them.

ELECTRO-HYDRAULIC CONTROL SYSTEM

AUTOMATIC TRANSMISSION

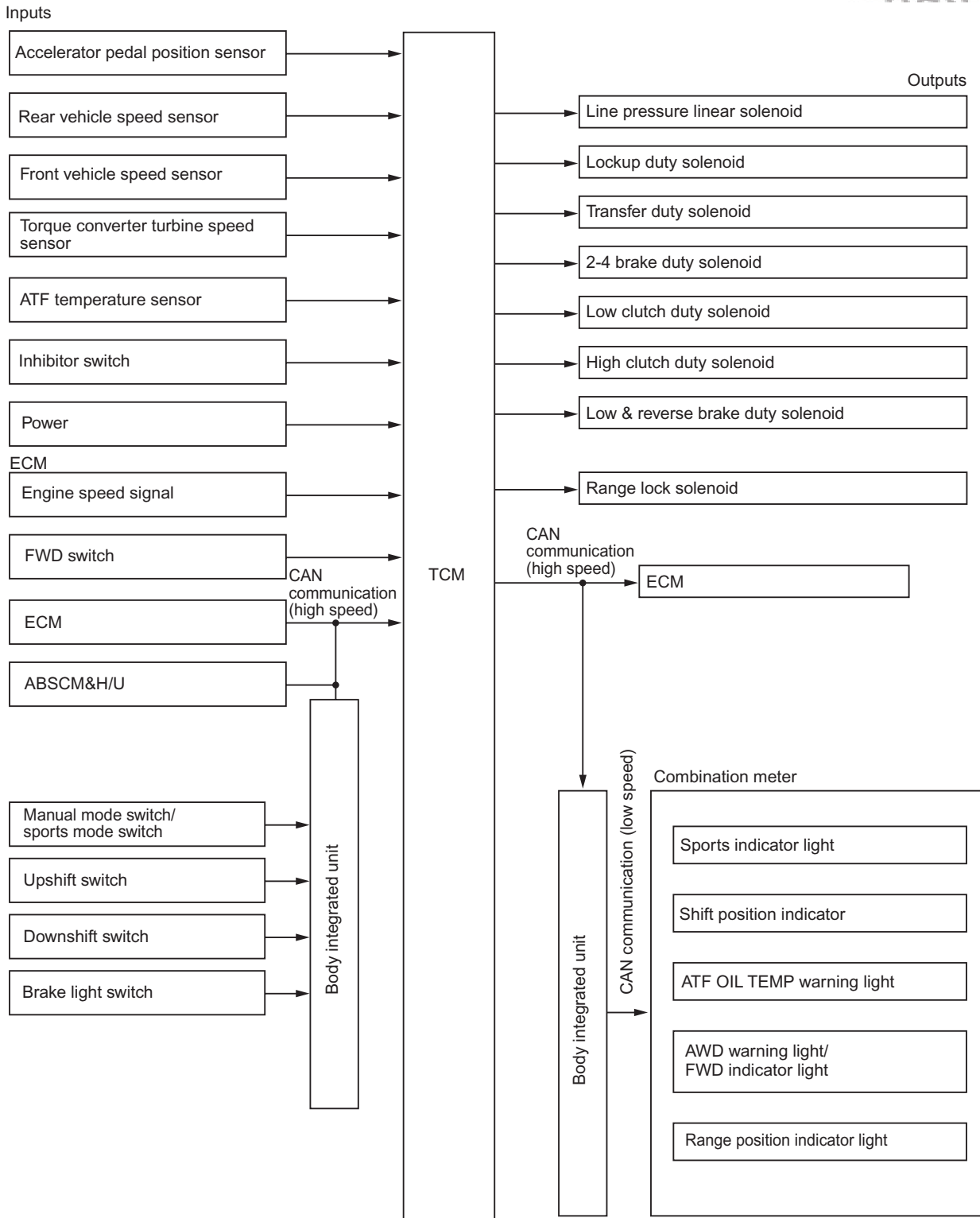

AT-02934

ELECTRO-HYDRAULIC CONTROL SYSTEM

AUTOMATIC TRANSMISSION

B: INPUT SIGNALS

Signal name	Major function
Accelerator pedal position sensor	Indicates the throttle opening. This signal is used to determine shift point, line pressure, and lockup engaging vehicle speed, which vary with engine load.
Front vehicle speed sensor (located on transmission case)	Indicates the vehicle speed. This signal is used for control of gear shifting, lockup engaging, line pressure, and transfer clutch operation.
Rear vehicle speed sensor (located on extension case)	Used to control transfer clutch, and also as backup signal in case of failure of front vehicle speed sensor.
Engine speed signal	Indicates the engine speed. This signal is used for control of lockup clutch to ensure smooth engagement.
Inhibitor switch	Used to determine gears and line pressures in each of ranges P, R, N, and D.
ATF temperature sensor	Indicates the ATF temperature. This signal is used for inhibition of lockup, release of OD and determination of ATF temperature.
FWD switch	Used for changing the mode from AWD to FWD. Also used for adapting the vehicle to FWD tester roller. Changeover from AWD to FWD can be made by inserting a fuse into the fuse holder.
Torque converter turbine speed sensor	Tells the rotation speed of the input shaft. The proportion of this speed to the vehicle speed determines whether shifting should be made or not.
CAN communication signals	Receives information from ECM, ABSCM and body integrated unit to control the transmission.

C: OUTPUT SIGNALS

Signal name	Function
Line pressure linear solenoid	Regulates the line pressure according to driving conditions.
Lockup duty solenoid	Regulates the hydraulic pressure of the lockup clutch to operate it in three modes (open, smooth and lockup).
Transfer duty solenoid	Regulates the hydraulic pressure of the transfer clutch to control the driving force to the rear drive shaft.
2-4 brake duty solenoid	Regulates 2-4 brake operating pressure to reduce shifting shocks.
High clutch duty solenoid	Regulates high clutch operating pressure to reduce shifting shocks.
Low clutch duty solenoid	Regulates low clutch operating pressure to reduce shifting shocks.
Low & reverse duty solenoid	Regulates low & reverse brake operating pressure to reduce shifting shocks.
Shift lock solenoid	Controls the shift lock solenoid during range lock control.
CAN communication signals	Outputs transmission information to control modules and the body integrated unit.

ELECTRO-HYDRAULIC CONTROL SYSTEM

AUTOMATIC TRANSMISSION

D: CONTROL ITEMS

Control items		Description of control	
Transmission control	Shifting control	Base shift control	Upshifting and downshifting are set for each range, gear and pattern according to the accelerator pedal position and vehicle speed.
		ABS-in-operation control	Gear speed is determined according to vehicle speed when ABS signal and brake signal is input.
		ATF low temperature control	Shifting into 4th gear is prevented when ATF temperature is below the preset value.
		Sports pattern control (SPORTS light ON)	Sports pattern is selected when the select lever is moved to the manual mode position.
		Base pattern control (SPORTS light OFF)	Base pattern is selected when the select lever is in D range.
	Lockup control	Base lockup control	Lockup control is performed according to throttle position and vehicle speed. (Basically lockup is OFF during gear shifting.)
		Smooth control	Smooth lockup is performed when lockup is switched on.
	Line pressure control	Ordinary control	Line pressure is regulated according to the accelerator pedal position and vehicle speed signals.
	Shift timing control	Gear speed control	Controls each solenoid.
		Lockup control	When shifting, the lockup clutch is temporarily released.
	Adaptive control	Accelerator pedal quick return control	When the accelerator pedal is quickly released from a depressed condition, the gear is held in the current speed.
		Accelerator pedal quick depressing control	When the accelerator pedal is quickly depressed, the transmission down shifts immediately.
		Map switch control	Switches the shift point setting according to the driving condition.
		Braking control	To ensure engine braking effect during braking and improve the re-acceleration performance, the transmission is downshifted in accordance with the deceleration.
	CAN communication signals control		Sends and receives vehicle information between control modules and controls each module.
AWD transfer clutch control	Ordinary transfer control	Transfer clutch pressure is regulated according to the throttle valve angle, vehicle speed, and engine torque.	
	Slip control	Regulates transfer clutch pressure in accordance with the amount of slip.	
	Turning control	Transfer clutch pressure is reduced after detecting a turn.	
	ABS-in-operation control	Transfer clutch pressure is adjusted to a set level immediately after reception of ABS signal.	

Brought to you by Eris Studios
NOT FOR RESALE

12.Sensor Systems

A: ACCELERATOR PEDAL POSITION SENSOR

The accelerator pedal position sensor provides electrical signals corresponding to accelerator pedal position. The throttle valve angular position and accelerator depressing speed are detected by this accelerator pedal position sensor.

B: REAR VEHICLE SPEED SENSOR

This vehicle speed sensor (output shaft speed sensor) is a Hall element type sensor and is externally mounted on the extension case. It detects the rear drive shaft speed in terms of the peripheral speed of the transfer clutch drum and sends pulse signals (30 pulses per rotation) to the TCM.

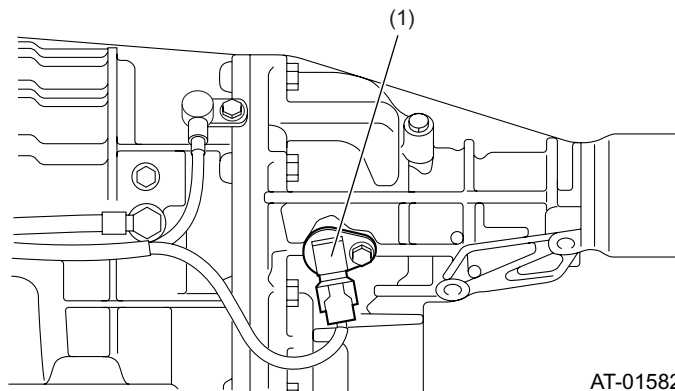

AT-01582

(1) Rear vehicle speed sensor

C: FRONT VEHICLE SPEED SENSOR

This vehicle speed sensor (output shaft speed sensor) is externally mounted on the transmission case. It detects the front drive pinion shaft speed and sends sine wave signals (16 pulses per rotation) to the TCM.

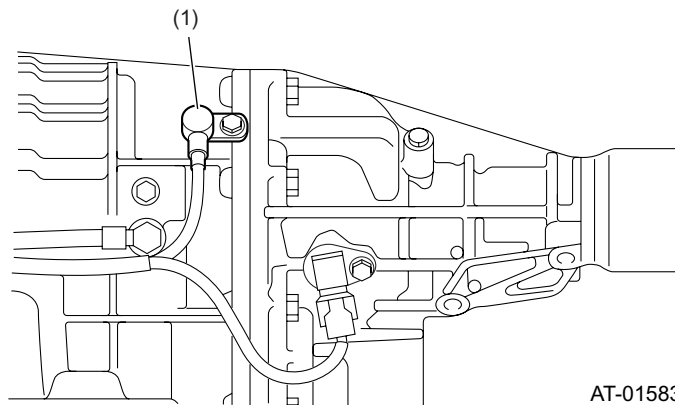

AT-01583

(1) Front vehicle speed sensor

SENSOR SYSTEMS

AUTOMATIC TRANSMISSION

D: ATF TEMPERATURE SENSOR

This sensor is integrated with the transmission harness and is mounted on the transmission control valve body. Its resistance varies in accordance with the ATF temperature. The characteristics of the sensor are as shown below.

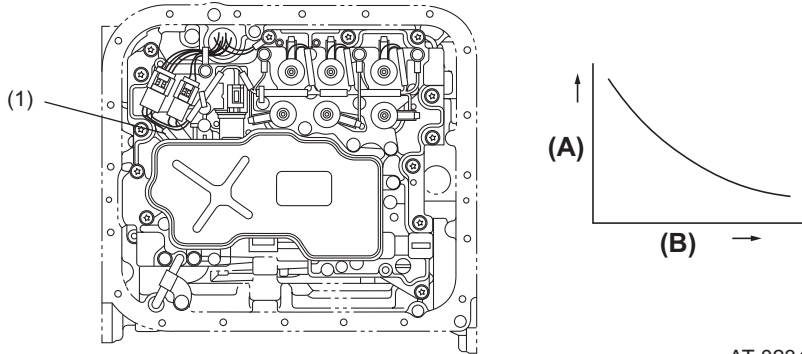

AT-02348

(1) ATF temperature sensor

(A) Resistance

(B) Temperature

E: TORQUE CONVERTER TURBINE SPEED SENSOR

The torque converter turbine speed sensor (output shaft speed sensor) is externally mounted on the transmission case.

The sensor detects the torque converter turbine speed in terms of the rotation speed of the periphery of the high clutch drum coupled to the input shaft, and sends sine wave signals (32 pulses per rotation) to the TCM. The TCM converts this signal into turbine speed to use it for shifting control.

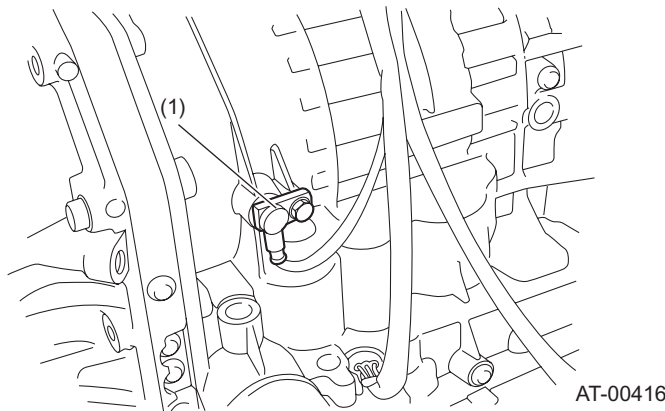

AT-00416

(1) Torque converter turbine speed sensor

F: INHIBITOR SWITCH

The inhibitor switch assures safety when starting the engine. This switch is mounted on the right side of the transmission case, and is operated by the selector lever.

When the selector lever is set to P or N, the electrical circuit in the inhibitor switch is connected to the starter circuit to enable cranking of the engine.

When the selector lever is in the R or D range, the electrical circuit in the inhibitor switch is disconnected. Hence engine cranking is disabled. In the R range, the backup light circuit is completed in the switch, and the backup lights come on.

In addition to the above function, the inhibitor switch incorporates a circuit for detecting the selected range position and sending the range signal to the TCM.

Inhibitor switch side connector

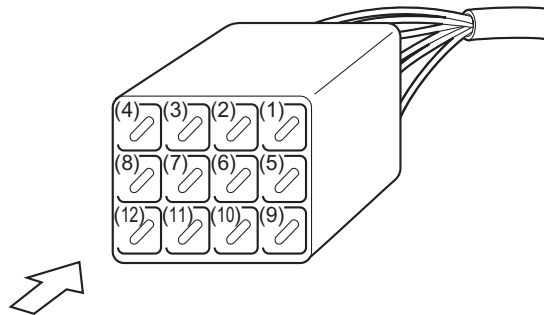

AT-00417

Range position	Pin No.
P	(4) — (3) (12) — (11)
R	(4) — (2) (10) — (9)
N	(4) — (1) (12) — (11)
D	(4) — (8)

SENSOR SYSTEMS

AUTOMATIC TRANSMISSION

G: LINE PRESSURE LINEAR SOLENOID

This solenoid is mounted on the transmission control valve. This adjusts the line pressure in response to electrical current instructions from the TCM. The line pressure is regulated to an optimum level according to the driving condition.

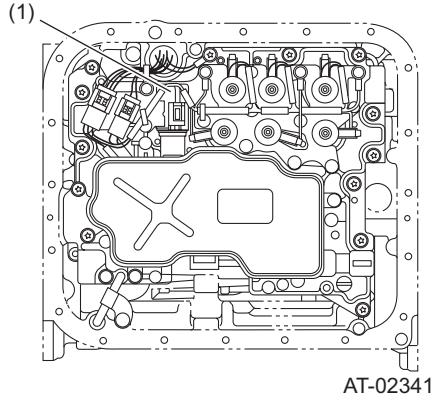

AT-02341

(1) Line pressure linear solenoid 2

H: 2-4 BRAKE DUTY SOLENOID

This solenoid is mounted on the transmission control valve. This adjusts the pressure applied to the 2-4 brake in response to the duty instructions from the TCM. The engaging force of the 2-4 brake during shifting is properly controlled and shift shocks are reduced.

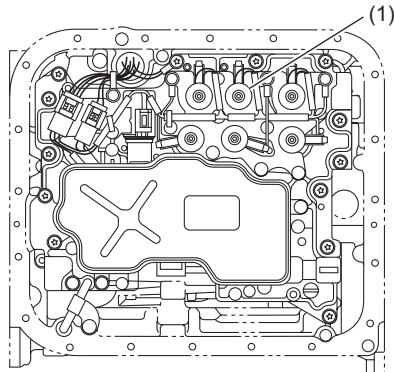

AT-02342

(1) 2-4 brake duty solenoid

I: LOCKUP DUTY SOLENOID

This solenoid is mounted on the transmission control valve. Its duty ratio is controlled by signals from the TCM. The solenoid provides smooth engagement and disengagement of the lockup clutch.

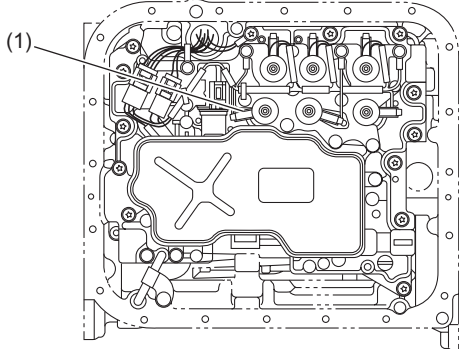

AT-02343

(1) Lockup duty solenoid

J: LOW CLUTCH DUTY SOLENOID

This solenoid is mounted on the transmission control valve. This adjusts the pressure applied to the low clutch in response to the duty instructions from the TCM. The engaging force of the low clutch during shifting is properly controlled and shift shocks are reduced.

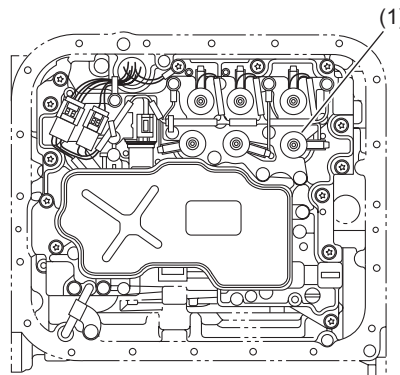

AT-02344

(1) Low clutch duty solenoid

SENSOR SYSTEMS

AUTOMATIC TRANSMISSION

K: HIGH CLUTCH DUTY SOLENOID

This solenoid is mounted on the transmission control valve. This adjusts the pressure applied to the high clutch in response to the duty instructions from the TCM. The engaging force of the high clutch during shifting is properly controlled and shift shocks are reduced.

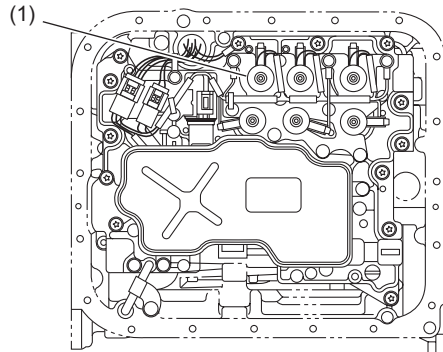

AT-02345

(1) High clutch duty solenoid

L: LOW & REVERSE BRAKE DUTY SOLENOID

This solenoid is mounted on the transmission control valve. This adjusts the pressure applied to the low & reverse brake in response to the duty instructions from the TCM. The engaging force of the low & reverse brake during shifting is properly controlled and shift shocks are reduced.

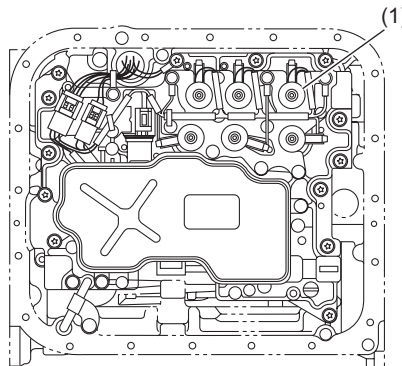

AT-02346

(1) Low & reverse brake duty solenoid

M: TRANSFER DUTY SOLENOID

This solenoid is mounted on the transmission control valve. This adjusts the pressure applied to the transfer in response to the duty instructions from the TCM. Torque distribution to the front and rear is controlled by properly controlling the engagement force of the transfer clutch.

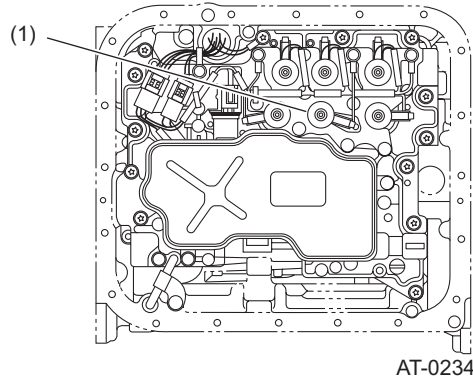

AT-02347

(1) Transfer duty solenoid

TRANSMISSION CONTROL MODULE (TCM)

AUTOMATIC TRANSMISSION

13. Transmission Control Module (TCM)

The TCM receives various sensor signals and determines the running conditions of the vehicle. It then sends control signals to each solenoid according to the preset gearshift characteristic data, lockup operation data, and transfer clutch torque data (duty ratios).

A: CONTROL SYSTEM

	Control items	Input signals
Shifting control	Ordinary shift control	Accelerator pedal position signal Rear vehicle speed signal Front vehicle speed signal Engine speed signal Range signal
	ABS-in-operation control	ABS signal Rear vehicle speed signal Front vehicle speed signal Brake switch signal
	Shift pattern select control	Cruise control signal ATF temperature signal Accelerator pedal position signal Manual mode switch signal
	Grade control	Accelerator pedal position signal Rear vehicle speed signal Front vehicle speed signal Brake switch signal Range signal Engine speed signal Engine torque signal
	Sports shift control	CAN communication signals (sports mode switch, upshift switch, downshift switch) Front vehicle speed signal Rear vehicle speed signal Engine speed signal ATF temperature signal Range signal
	Adaptive control	Accelerator pedal position signal Front vehicle speed signal Rear vehicle speed signal Engine speed signal ATF temperature signal Brake switch signal Torque converter turbine speed signal
Lockup control	Ordinary lockup control	Accelerator pedal position signal Rear vehicle speed signal Front vehicle speed signal Engine speed signal Range signal
	Hydraulic oil temperature control	ATF temperature sensor

TRANSMISSION CONTROL MODULE (TCM)

AUTOMATIC TRANSMISSION

Control items		Input signals
Oil pressure control	Ordinary pressure control	Accelerator pedal position signal Rear vehicle speed signal Front vehicle speed signal Engine speed signal Inhibitor switch signal ATF temperature signal
	Shifting control	Accelerator pedal position signal Rear vehicle speed signal Front vehicle speed signal Engine speed signal Torque converter turbine speed signal Range signal ATF temperature signal
AWD transfer clutch control	Ordinary transfer control	Accelerator pedal position signal Rear vehicle speed signal Front vehicle speed signal Range signal ATF temperature signal FWD switch signal
	Slip detection control	Accelerator pedal position signal Rear vehicle speed signal Front vehicle speed signal
	Steering control	Throttle position signal Rear vehicle speed signal Front vehicle speed signal
	ABS-in-operation control	ABS signal Rear vehicle speed signal Front vehicle speed signal Brake switch signal
Range lock control		Front vehicle speed signal Rear vehicle speed signal Range signal

TRANSMISSION CONTROL MODULE (TCM)

AUTOMATIC TRANSMISSION

B: SCHEMATIC DIAGRAM

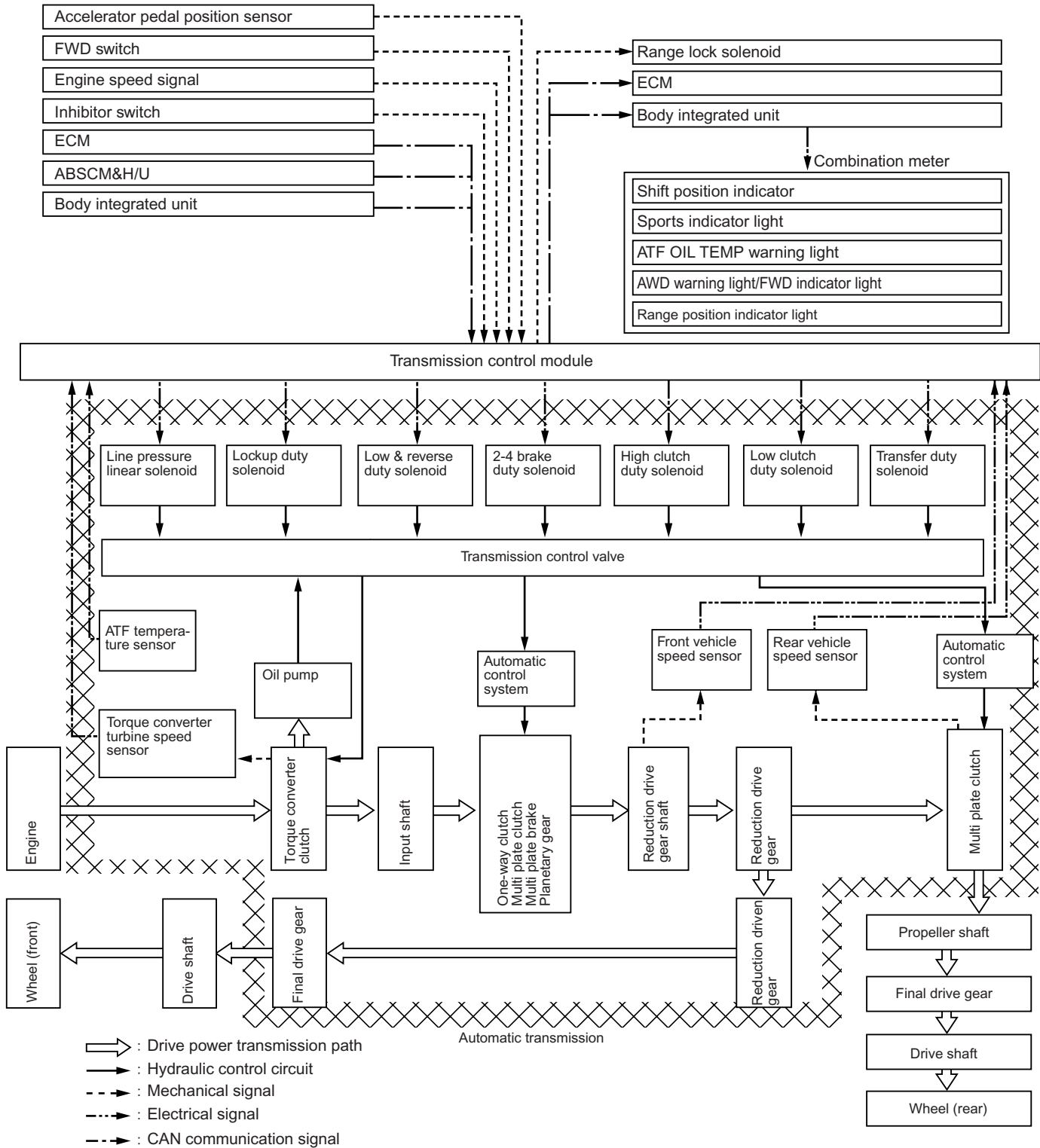

AT-02935

C: SHIFTING CONTROL

1. ORDINARY SHIFT CONTROL

The TCM controls each solenoid based on input signal information such as inhibitor switch signals, vehicle speed signals and accelerator pedal position signals, to automatically select the optimum gear position from the shifting map.

2. ENGINE COOPERATIVE CONTROL

During shifting, the TCM outputs a torque-down requirement signal, and the ECM receives this to retard the ignition timing of each cylinder to temporarily decrease the output torque from the engine. Simultaneously with this control, the TCM constantly monitors the shift sequence through vehicle speed sensors and the turbine speed sensor to perform feedback control and optimize gear shifts. Because of this control, a smooth and comfortable gear shifting is ensured under all conditions.

3. ABS COOPERATIVE CONTROL

When the ABS is operating, the optimum gear speed for the vehicle speed is selected by cooperative operation with the ABSCM to prevent degrading the operation of the ABS.

4. CONTROL AT HIGH OIL TEMPERATURES

If the ATF temperature becomes extremely high, shifting control is performed by automatically switching to a shifting map that is less likely to cause temperature rise.

5. CONTROL WHEN ATF OR ENGINE COOLANT TEMPERATURE IS LOW

When the ATF temperature or engine coolant temperature is extremely low at engine start, etc., shifting control is performed by automatically switching to a shifting map that causes temperature rise easier.

6. CONTROL WHEN CRUISE CONTROL IN OPERATION

When the cruise control is operating, shifting control is performed by automatically switching to a shifting map that is suitable for cruise control.

TRANSMISSION CONTROL MODULE (TCM)

AUTOMATIC TRANSMISSION

D: LOCKUP CONTROL

- The TCM has pre-programmed lockup clutch engagement and disengagement conditions for each gear and shift pattern. The engagement and disengagement conditions are defined in terms of the accelerator pedal position and vehicle speed.
- The TCM controls lockup clutch operation through duty solenoids.

1. NON-LOCKUP OPERATION

The duty solenoid allows the pilot pressure to be applied to the disengaging end of the valve in the control valve body. The valve then opens the clutch disengaging circuit port to add the lockup operating pressure (torque converter clutch regulating pressure) to the disengaging circuit. Moreover, the valve opens the lockup clutch engaging circuit port and allows the hydraulic fluid in the circuit to flow to the ATF cooler, thus lowering the pressure in the circuit. As a result, the lockup clutch is disengaged due to difference in pressure between both circuits.

This control is performed in all gear positions.

2. LOCKUP OPERATION

The duty solenoid allows the pilot pressure to be applied to the engaging end of the valve in the control valve body. The valve then opens the clutch engaging circuit port that communicates to the torque converters impeller chamber, allowing high pressure fluid to flow to the lockup clutch. The clutch then engages.

- The TCM controls the current to the duty solenoid by gradually changing the current. As a result, the valve also moves gradually, so the clutch engagement pressure increases smoothly. This causes the lockup clutch to become initially in a half-engaged state and then in a fully engaged state, thus preventing shock during engagement.

This control is performed in all gear positions.

E: LINE PRESSURE CONTROL

The oil pump discharge pressure (line pressure) is controlled by the line pressure linear solenoid and the line pressure is regulated to an optimum level corresponding to the vehicle's running conditions.

1. LINE-PRESSURE CONTROL DURING SHIFTING

The line pressure is controlled by the TCM as follows to meet varying operating conditions.

- The TCM receives throttle angle signals, and the TCM sends a control signal to the line pressure linear solenoid. The pressure from the line pressure linear solenoid is sent to the valve where the line pressure is regulated. The valve adjusts the oil-pump-generated line pressure to make the line pressure matched to the driving condition.

F: SHIFT PATTERN SELECTION CONTROL

1. ADAPTIVE CONTROL

This control is performed to improve the drivability of the vehicle by optimizing gear shifts in accordance with the driver's intention to accelerate or decelerate, and driving conditions such as hill climbing and descending, etc.

- Shift pattern automatic switching control

This control enables selection of the optimum gear speed by automatically switching the shift pattern by estimating driver's intentions and driving conditions through sensor information such as driving resistance, engine speed, acceleration, vehicle speed, and also from calculated values.

Any of the three patterns NORMAL, SPORTS, and SLOPE are continuously and automatically selected under the following conditions.

D range

NORMAL ↔ SPORTS ↔ SLOPE

D range, in sports mode

SPORTS ↔ SLOPE

Normal pattern: covers a wide range from normal driving to high speed driving.

Sports pattern: a shift pattern suitable for driving conditions requiring deep accelerator pedal positions, such as winding road driving.

Slope pattern: this shift pattern controls upshifting to prevent too frequent gear shifting during climbing or descending hills. By combining braking control (in sports mode only) (explained later), engine braking will be positively used when descending hills.

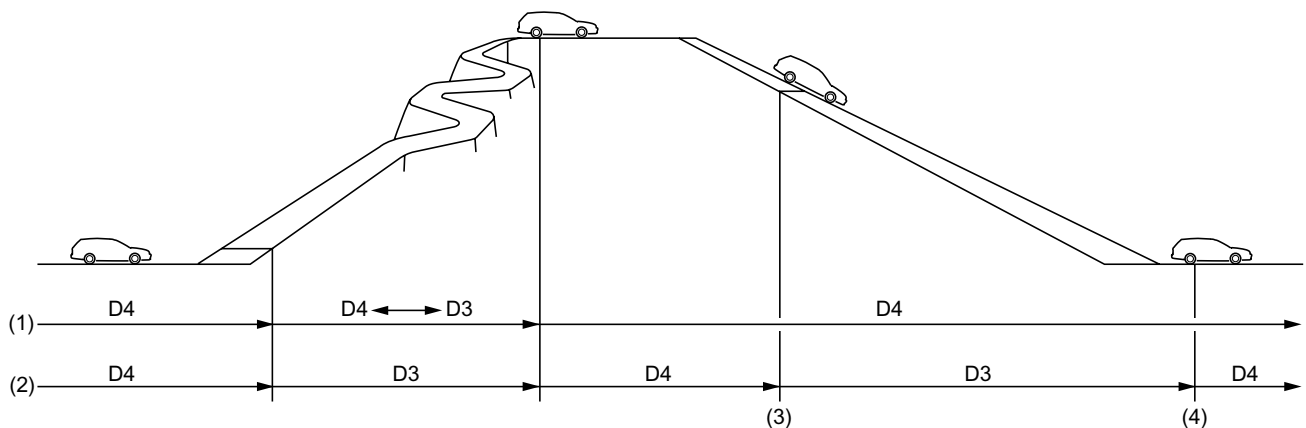

AT-00431

(1) Without climbing and descending control

(2) With climbing and descending control

(3) Brake pedal ON

(4) Re-acceleration

TRANSMISSION CONTROL MODULE (TCM)

AUTOMATIC TRANSMISSION

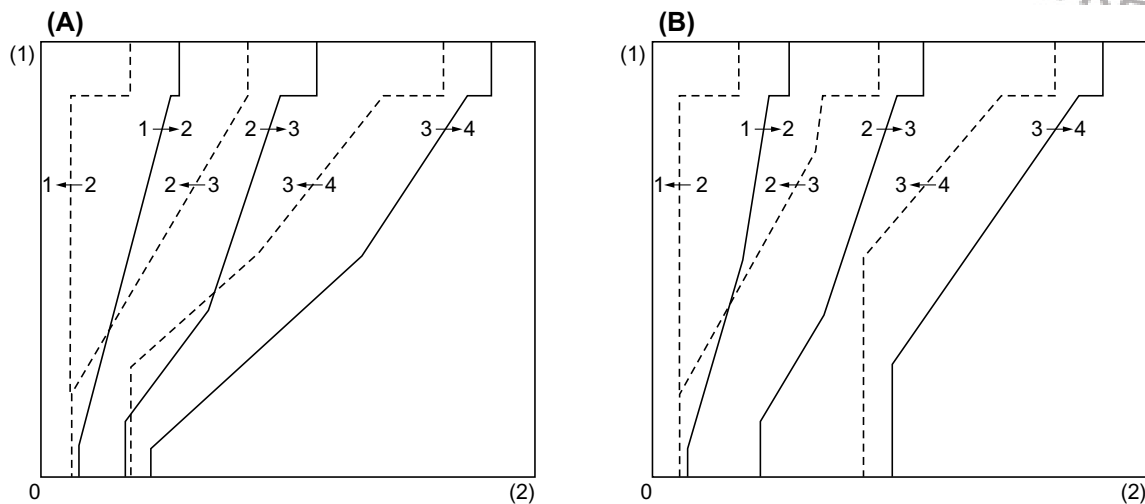

AT-00432

(A) Base pattern
(1) Accelerator pedal position

(B) Grade control pattern
(2) Vehicle speed

- Accelerator pedal quick depressing control

When the accelerator pedal is quickly depressed, the TCM interprets this as acceleration is required, and the transmission is downshifted earlier to obtain a greater drive force.

- Accelerator pedal quick return control

When the accelerator pedal is quickly released, the TCM interprets this as deceleration is required, and upshift is prohibited in order to hold the transmission in the current gear speed to prevent frequent shifting and to maintain engine braking effect (operates in sports mode only).

- Braking control

According to the braking force (deceleration) during braking, downshifts are hastened to ensure engine braking effect and obtain a larger driving power for accelerating after braking (operates in sports mode only).

2. SPORTS MODE CONTROL

When the shift lever is moved toward the manual gate side in D range, the SPORT light in the combination meter illuminates and the system enters the Sports mode. Gearshift timings are set at higher vehicle and engine speeds to make more use of low speed gears. The full lockup vehicle speed in 4th is also set higher than in the normal mode.

3. MANUAL MODE CONTROL

By operating the “+” or “-” switch on the select lever in D range with the sports shift switch ON (in sports mode), the system switches to manual mode. In this state, operating the “+” switch causes upshifting while operating the “-” switch causes downshifting; manual shifting is enabled and the selected gear position is held while driving.

However, at certain vehicle speeds or ATF temperatures, the following inhibiting control is performed.

- Upshift inhibiting and auto downshift control

The gear upshifts each time the “+” switch is operated, however, when the vehicle speed is too low

TRANSMISSION CONTROL MODULE (TCM)

AUTOMATIC TRANSMISSION

for the selected gear speed, the TCM inhibits further upshifting. If the vehicle speed becomes too slow for the current gear speed, a downshift will be made automatically to prevent engine stall. When the vehicle comes to a stop, the transmission will always be controlled to shift to 1st speed unless the vehicle was in Manual mode 2nd hold control.

- Downshift inhibiting control

The gear downshifts each time the “-” switch is operated, however, when the vehicle speed is too low for the selected gear speed, the TCM inhibits further shifting. A manual shifting inhibiting buzzer will sound to warn the driver.

- Engine over speed prevention control

If the engine speed exceeds the preset value during accelerating, the fuel supply is cut to prevent over-revving of the engine.

- Control when the temperature is low or hot

When the ATF temperature is low as in cases such as immediately after start in winter, upshifting to 4th is inhibited to quicken warm up. Upshifting to 4th is also inhibited if the ATF temperature becomes extremely high after severe driving, to prevent further temperature rise.

4. 2nd HOLD CONTROL (IN MANUAL MODE)

When the “+” switch is operated when the vehicle is in Manual mode and not moving, the transmission shifts to 2nd speed enabling start in 2nd. This status is held unless the manual mode is canceled, or a speed other than 2nd is selected with the “-” switch. Also, the transmission is held in 2nd when the vehicle is stopped.

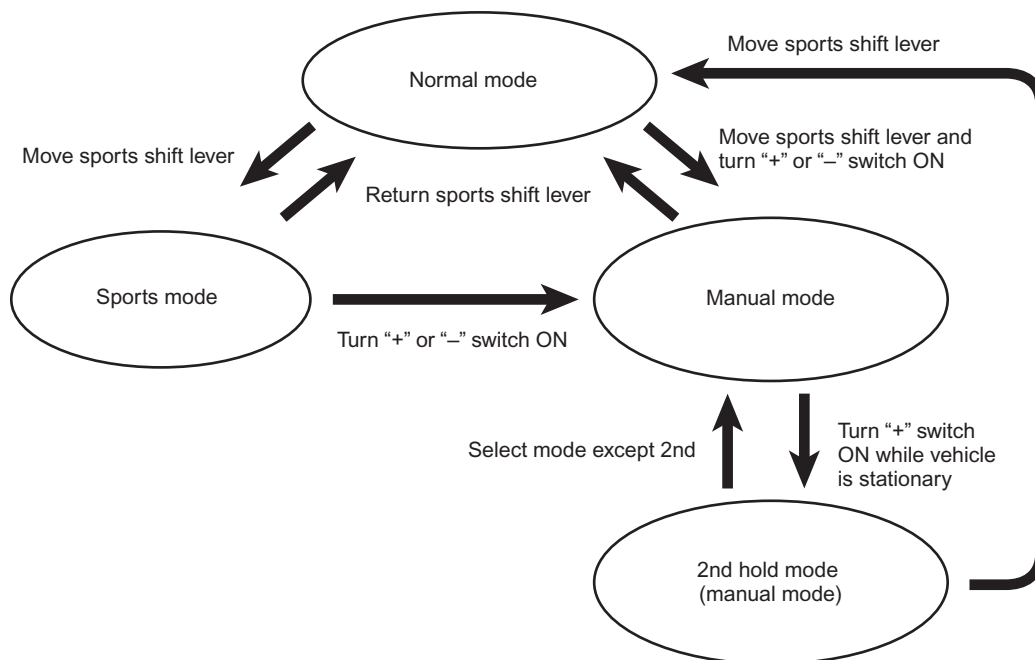

AT-02340

TRANSMISSION CONTROL MODULE (TCM)

AUTOMATIC TRANSMISSION

5. ILLUMINATION CONTROL OF VARIOUS INDICATORS

Illuminations of the various indicators on the combination meter are controlled in accordance with the shift pattern selection as shown below.

Status \ Indicator	D ●	SPORT	▲ ▼	1	Operation mode
Normal D range	D ●	SPORT	△ ▽	(extinguished)	Normal mode
In sports mode	D ●	SPORT	△ ▽	(extinguished)	Sports mode
Manual shift mode	D ○	SPORT	▲ ▼	1 — 4	Manual mode

NOTE:
Indicators printed in solid black show their illuminated status.

AT-02881

TRANSMISSION CONTROL MODULE (TCM)

AUTOMATIC TRANSMISSION

G: LEARNING CONTROL OF SHIFTING HYDRAULIC PRESSURES

To constantly ensure excellent shift quality regardless of the variance between friction material and aging, learning control of shifting hydraulic pressures is used.

Learning takes place for every normal shifting under certain conditions, and the learned values are not lost even when the power is turned OFF (or battery's negative terminal disconnected).

H: RANGE LOCK CONTROL

This control prevents the select lever from being moved to the R position when the vehicle is running. Thus damage to components such as the reverse clutch is prevented.

When the specified speed is exceeded the TCM turns off the shift lock solenoid for the select lever. Therefore the range lock control works to inhibit operation from N range to R range, preventing the transmission from put into reverse.

TRANSMISSION CONTROL MODULE (TCM)

AUTOMATIC TRANSMISSION

I: CAN COMMUNICATION SIGNALS CONTROL

By interchanging information between control modules such as the TCM, ECM, ABSCM & H/U, etc., the modules are controlled in accordance with the vehicle's driving conditions.

In CAN (Controller Area Network) communication, each control module is connected with 2 lines and a large amount of information is interchanged through such a small number of wiring. Each control module sends and receives information and reads only the necessary information for its own purpose.

Main signals sent and received for transmission control

	TCM	ECM	ABSCM&H/U	Body integrated unit	Combination meter
Sports mode switch-cum-manual mode switch signal	IN			OUT	
Upshift signal (manual mode)	IN			OUT	
Downshift signal (manual mode)	IN			OUT	
Brake switch signal	IN			OUT	
ABS signal	IN		OUT		
ENG AT cooperation signal	IN	OUT			
	OUT	IN			
Range position signal	OUT	IN		IN/OUT	IN
AT warning light signal (SPORT indicator light)	OUT			IN/OUT	IN
Sports shift warning buzzer signal	OUT			IN/OUT	IN
AWD warning light signal Also used as FWD indicator light signal	OUT			IN/OUT	IN

IN: received

OUT: sent

TRANSMISSION CONTROL MODULE (TCM)

AUTOMATIC TRANSMISSION

J: AWD TRANSFER CLUTCH CONTROL

● Basic control

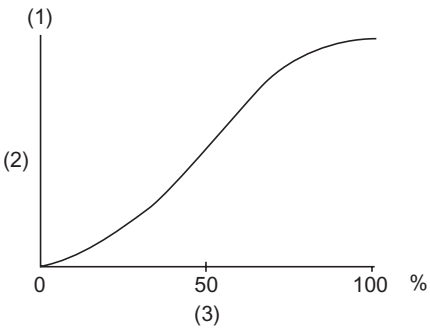
Type of control	Regulates transfer clutch pressure in response to engine torque, throttle position and vehicle speed.
Gear position	1st thru 4th and reverse
Remarks	 <p style="text-align: center;">AT-01761</p> <p>(1) Ordinary control (2) Transfer clutch capacity (3) Duty-ratio</p>

● Slip control

Type of control	Regulates transfer clutch pressure in accordance with the amount of slip.
Gear position	1st thru 4th and reverse
Remarks	Release: Released when the amount of slip becomes smaller than the specified value.

● Turning control

Type of control	Decreases transfer clutch pressure upon detection of a turn.
Gear position	1st thru 4th and reverse
Remarks	—

● ABS control

Type of control	Regulates to the specified transfer clutch pressure quickly when the ABS signal is input.
Gear position	1st thru 4th and reverse
Remarks	—

● P and N range control

Type of control	Regulates to the specified transfer clutch pressure immediately after a P or N range signal is input.
Gear position	P and N
Remarks	—

ON-BOARD DIAGNOSTICS SYSTEM

AUTOMATIC TRANSMISSION

14. On-board Diagnostics System

A: FUNCTION

The on-board diagnostics system detects and stores in the form of a code a fault that has occurred in any of the following input and output signal systems.

Rear vehicle speed sensor	High clutch duty solenoid	Sports shift switch
Front vehicle speed sensor	Low & reverse duty solenoid	Engine speed signal
Throttle position sensor	Transfer duty solenoid	Lockup clutch
Line pressure linear solenoid	ATF temperature sensor	Torque converter turbine speed sensor
2-4 brake duty solenoid	CAN communication signal circuit	1, 2, 3, 4, R gear ratios
Lockup duty solenoid	Inhibitor switch	Shift lock solenoid
Low clutch duty solenoid	Brake switch	

If a fault has been detected, the system tells the fault by causing the SPORT indicator light to blink.

B: OPERATION OF SPORT INDICATOR LIGHT

On starting the engine, the SPORT indicator light illuminates and then goes out as shown in the Normal diagram below. If any problem exists, the light continues flashing as shown in the Abnormal diagram below.

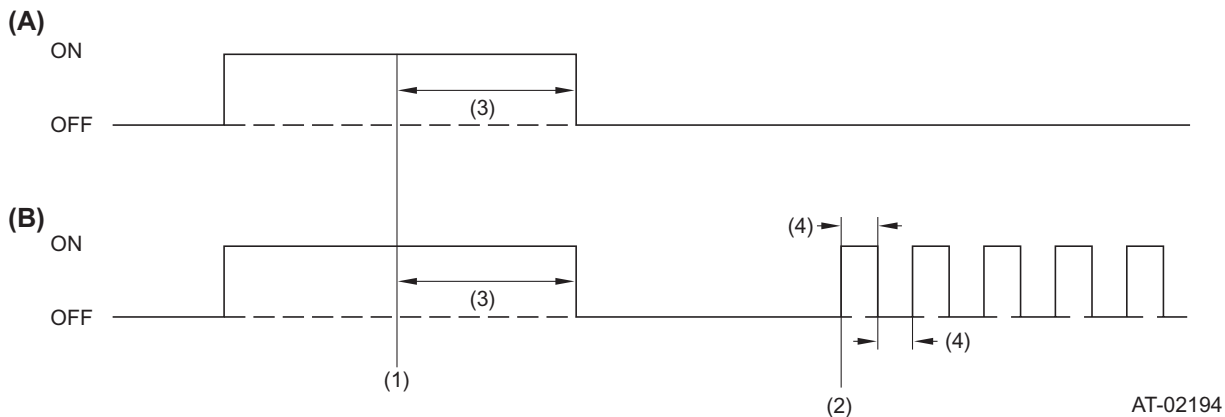

- (A) When normal
- (B) When abnormal

- (1) Engine cranking
- (2) After abnormality is detected
- (3) 2 seconds
- (4) 0.25 seconds

AT-02194

15.Fail-safe Function

The failsafe control function ensures minimum level of drivability even if a fault should occur in the vehicle speed sensors, accelerator pedal position sensor, inhibitor switch, or any of the solenoids.

- Front and rear vehicle speed sensors

A dual speed-sensing system is used. The speed signal is taken from the transmission (by the output shaft speed sensor). Even if one sensor system fails, the vehicle can be controlled normally with the other normally operating sensor system.

- Accelerator pedal position sensor

If the accelerator position sensor becomes faulty, control will be maintained by assuming that the accelerator pedal position is at a certain angle.

- Inhibitor switch

If the TCM receives different signals simultaneously from a faulty inhibitor switch, it selects a range in the following priority:

D > R > N > P

- Line pressure linear solenoid

If the line pressure linear solenoid system fails, the solenoid is de-energized and the line pressure is raised to the maximum to enable the vehicle to operate.

- Lockup duty solenoid

If the lockup duty solenoid system fails, the solenoid is de-energized and the lockup clutch is disengaged.

- Transfer duty solenoid

When the transfer duty solenoid system becomes faulty, it is de-energized. This causes oil pressure to the transfer clutch to be interrupted and no power is transmitted to the rear axle. (FWD state)

- 2-4 brake duty solenoid

If a fault occurs in the 2-4 brake duty solenoid system, the solenoid is de-energized and the gears are limited to the 2nd or 3rd.

- Low clutch duty solenoid

If a fault occurs in the low clutch duty solenoid system, the solenoid is de-energized and the gears are limited to the 3rd or 4th.

- High clutch duty solenoid

If a fault occurs in the high clutch duty solenoid system, the solenoid is de-energized and the gears are limited to the 2nd or 3rd.

- Torque converter turbine speed sensor

If a fault occurs in the torque converter turbine speed sensor, the gears are limited to the 3rd speed.

- Low & reverse duty solenoid

If a fault occurs in the low and reverse duty solenoid system, the solenoid is de-energized and the gears are limited to the 1st.

TRANSMISSION MOUNTING

AUTOMATIC TRANSMISSION

16. Transmission Mounting

A: GENERAL

The transmission mounting consists of a pitching stopper, cushion rubber, and a cross member.

In addition to support the transmission, these components absorb noise and vibration caused by the transmission.

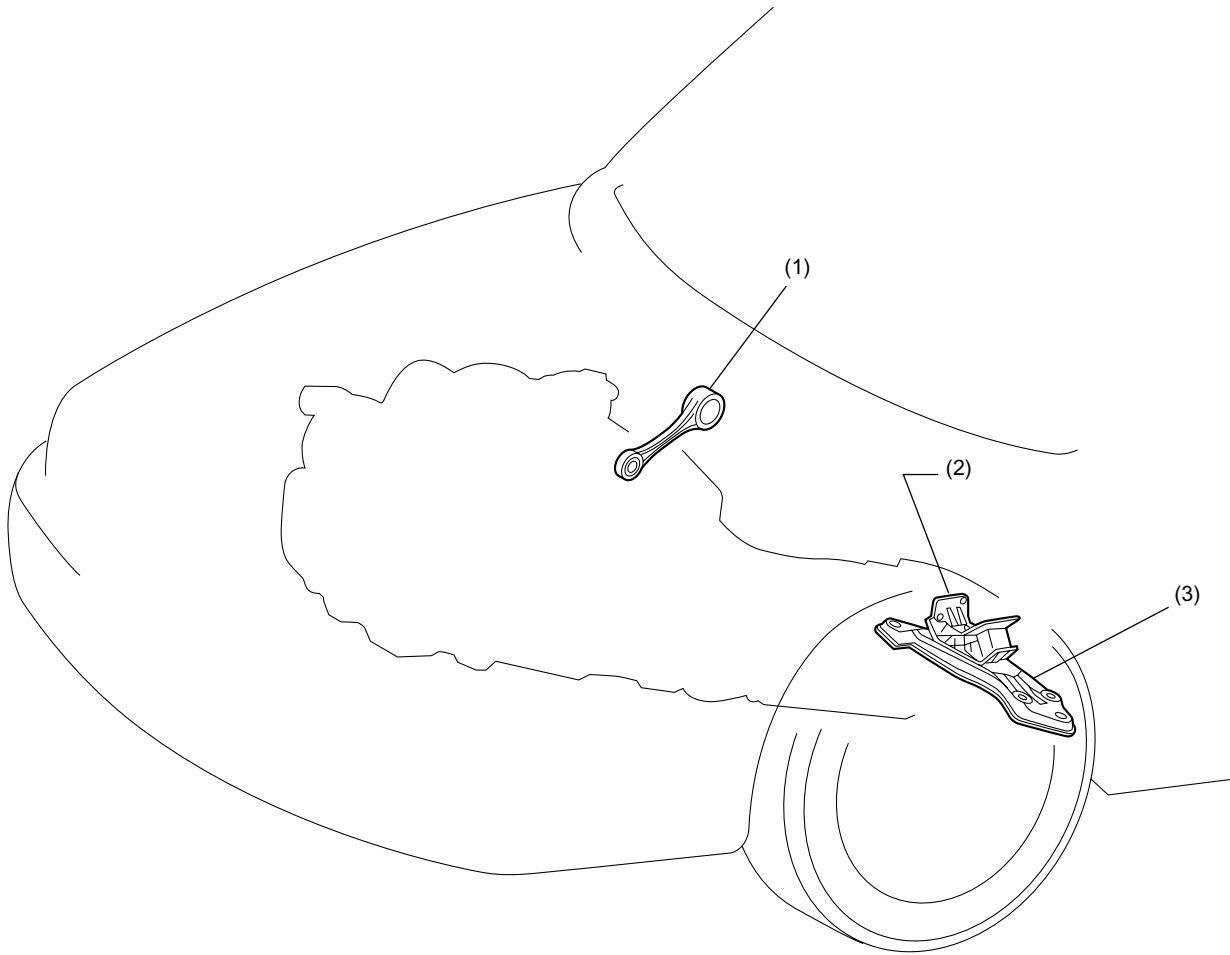

AT-00438

- (1) Pitching stopper
- (2) Cushion rubber
- (3) Cross member