

Brought to you by Eris Studios  
NOT FOR RESALE

# **MANUAL TRANSMISSION AND DIFFERENTIAL 6-SPEED (6MT)**

## 1. Driver's Control Center Differential System (From '06MY)

### A: GENERAL

The Driver's Control Center Differential (DCCD) system consists of the sensors and switches such as steering angle sensor, yaw rate and lateral G sensor, or stop light switch, the planetary gear type center differential (with built-in the LSD clutch), and the DCCD control module.

The center differential of double pinion gear type planetary unit distributes the engine torque to the front wheels and rear wheels at the torque ratio of 41:59.

(In the actual planetary gear unit, 3 sets of double pinion gears are used. But the figure shows only 2 sets of double pinion gears for simplification.)

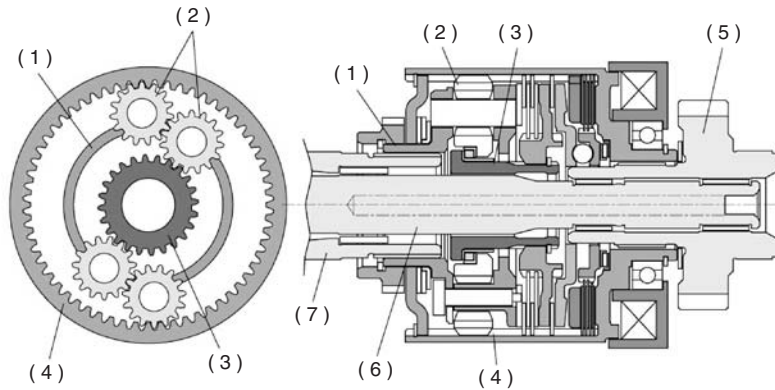

MT-01432

- |                   |                         |
|-------------------|-------------------------|
| (1) Carrier       | (5) Transfer drive gear |
| (2) Pinion gears  | (6) Drive pinion shaft  |
| (3) Sun gear      | (7) Driven shaft        |
| (4) Internal gear |                         |

# DRIVER'S CONTROL CENTER DIFFERENTIAL SYSTEM (FROM '06MY)

MANUAL TRANSMISSION AND DIFFERENTIAL

- The LSD mechanism improves the initial steering operation response further by combining and using the conventional solenoid clutch LSD mechanism and the torque sensing mechanical LSD mechanism.

When the solenoid clutch LSD is in the free condition, the mechanical LSD mechanism performs the differential control of 0 — 30%. The other 30 — 100% differential control can be performed by activating the solenoid clutch LSD.

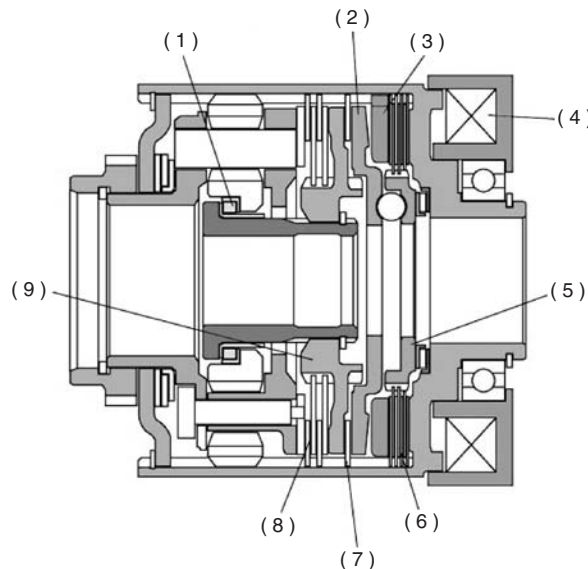

MT-01433

- |  |                         |
|--|-------------------------|
| (1) Torque cam                         | (5) Pilot clutch hub    |
| (2) Intermediate clutch pressure plate | (6) Pilot clutch        |
| (3) Armature                           | (7) Intermediate clutch |
| (4) Coil                               | (8) Main clutch         |
|  | (9) Main clutch hub     |

- The drivability and stability during cornering were made compatible by using the yaw rate and lateral G sensor and the newly adapted steering angle sensor. With this, the quick steering characteristics and the improvement of cornering ability are achieved, and the tight cornering symptom may also be decreased.

- In manual mode, the engagement power of solenoid clutch LSD can be adjusted within the range of 30 to 100%.

- When a malfunction occurs in the system, the fail-safe control may be performed that releases the solenoid clutch LSD so as to maintain safe conditions. At this time, the Subaru Select Monitor can be used for the system diagnosis.

# DRIVER'S CONTROL CENTER DIFFERENTIAL SYSTEM (FROM '06MY)

## MANUAL TRANSMISSION AND DIFFERENTIAL

### B: OPERATION

The DCCD system has the following 2 modes: "MANUAL MODE" and "AUTO MODE". In MANUAL MODE, as the operation amount of DCCD control dial (driver's will) is prioritized, the control that increases/decreases the engagement power of solenoid clutch LSD is performed. In AUTO MODE, the control that automatically adjusts the engagement power of solenoid clutch LSD corresponding to the input signals of steering angle sensor or yaw rate and lateral G sensor is performed.

#### NOTE:

The solenoid clutch LSD controls the differential control within the range of 30 to 100% [which excludes the differential control (0 — 30%) of the mechanical LSD].

#### Control of DCCD control module

Throttle sensing engagement power	Increases or decreases the engagement power of solenoid clutch LSD based on the amount of accelerator pedal depression by the driver.
ABS operation signal input	Decreases the engagement power of solenoid clutch LSD when the ABS operation signal is input from ABSCM&H/U to DCCD CM.
Brake switch signal input	Decreases the engagement power of solenoid clutch LSD when the brake switch signal is input to DCCD CM.
Parking brake signal input	Releases the solenoid clutch LSD when the parking brake signal to DCCD CM is input.
Tight cornering	Decreases the engagement power of solenoid clutch LSD by judging the vehicle condition from the steering angle sensor signal so as to prevent the tight cornering symptom.
Slip	Calculates the slip amount of each wheel based on the wheel sensor signal, and then corrects the engagement power of solenoid clutch LSD corresponding to the slip amount of wheel.
Cornering	Judges the vehicle cornering condition based on the signals of the steering angle sensor and the yaw rate and lateral G sensor so as to manage both drivability and stability of the vehicle during cornering.
DCCD control dial	Decreases or increases the engagement power of solenoid clutch LSD with the operation amount of the DCCD control dial of the driver.
Fail-safe	DCCD CM indicates the malfunction to the driver by blinking the light on the bottom of DCCD indicator when some malfunctions of system have been detected. When there is a serious malfunction in the DCCD coil, DCCD CM turns the DCCD coil OFF and releases the solenoid clutch LSD completely. If the malfunction is not a serious malfunction, such as the malfunctions of some sensors, DCCD CM performs the control that maintains the system operation as much as possible.
Rear differential oil temperature	When the rear differential oil temperature rises excessively [approximately 150°C (302°F)] for some reasons such as repetitive hard driving, the rear differential oil temperature switch turns ON and the rear differential oil temperature warning light of the combination meter illuminates. At the same time, DCCD CM performs the control that decreases the engagement power of solenoid clutch LSD. (If the oil temperature drops, the system returns to the normal control automatically.)