

Brought to you by Eris Studios
NOT FOR RESALE

BRAKE

FRONT AND REAR DISC BRAKES

BRAKE

1. Front and Rear Disc Brakes

- Each of the front and rear disc brakes consist of a brake caliper, brake pads, and a brake disk rotor.
- The front disc brakes are of a ventilated disc type which features high heat dissipation and superb braking stability. The rear disc brakes are either a ventilated disk type or a solid disk type.
- Each disc rotor, which is fitted on the outside of the hub, is secured together with the wheel using the hub bolts. This facilitates its removal and installation.
- The brake pads have a wear indicator which gives a warning when the pad is worn down to the limit.

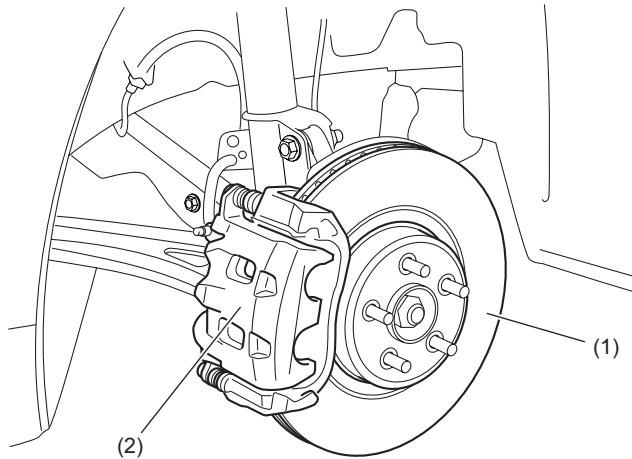

BR-00352

- (1) Disc rotor
- (2) Caliper body

A: PAD WEAR INDICATOR

A wear indicator is provided on the inner disc brake pads. When the pad wears down to 1.5 mm (0.059 in) the tip of the wear indicator comes into contact with the disc rotor, and makes a squeaking sound as the wheel rotates. This alerts the driver to the situation.

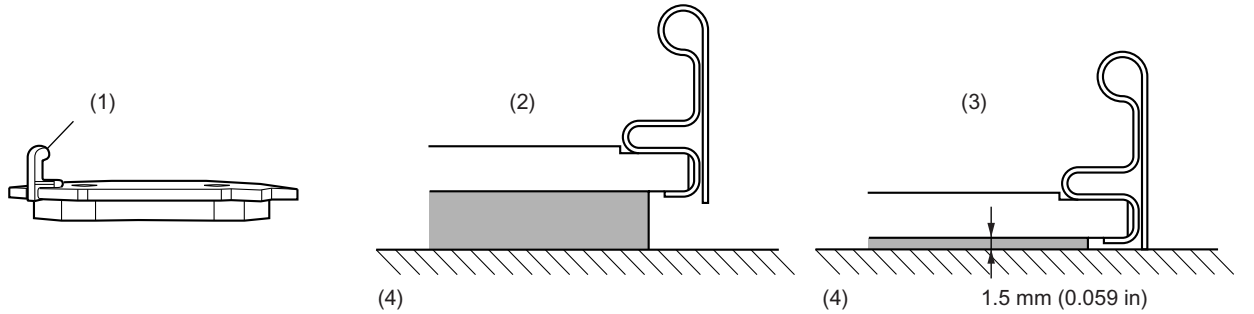

BR-00020

(1) Wear indicator

(2) New pad

(3) Worn pad

(4) Disc rotor

B: FRICTIONAL MATERIAL OF BRAKE PADS

The brake pads materials do not contain any asbestos which is harmful to human body.

MASTER CYLINDER

BRAKE

2. Master Cylinder

- The master cylinder consists of a brake fluid reservoir chamber that stores brake fluid, and a hydraulic chamber section that converts the force applied to the brake pedal into hydraulic pressure.
- The hydraulic pressure generated in each of the two hydraulic chambers are sent to the brake caliper of each wheel through the 2 diagonally split brake circuits.

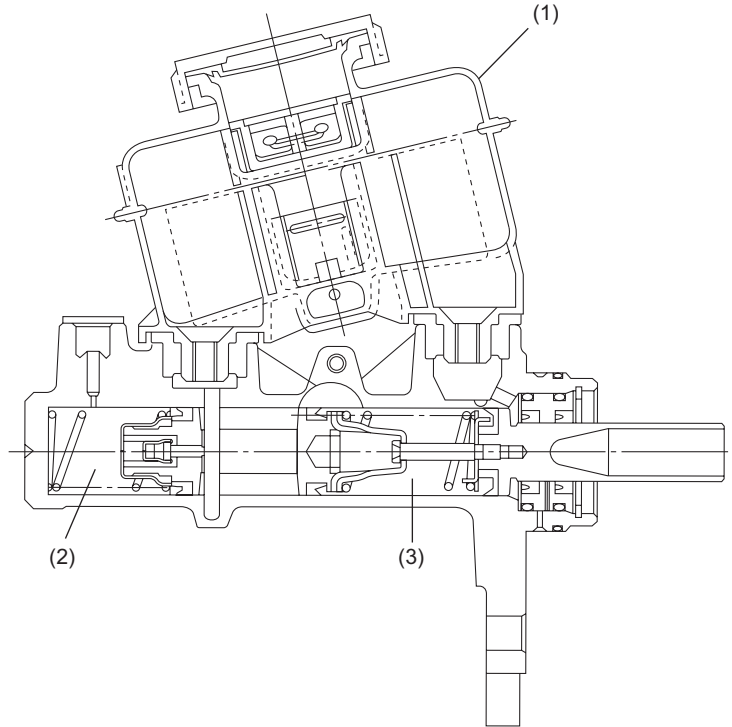

BR-00366

- (1) Reservoir tank
- (2) Secondary hydraulic chamber
- (3) Primary hydraulic chamber

A: BRAKE FLUID LEVEL SWITCH

The brake fluid level switch is located inside the brake fluid reservoir tank and causes the brake system warning light on the combination meter to come on when the fluid level has dropped below the predetermined level.

The switch assembly consists of a reed switch (normally open) and a permanent magnet that is incorporated in a float.

When the brake fluid level is normal, the float is far above the reed switch, so the force of the magnet is unable to act on the reed switch. The warning light circuit, therefore, remains open.

When the brake fluid level drops to a level approximately 20 mm (0.79 in) below the maximum level and the float lowers accordingly, the magnet aligns with the reed switch, activating the reed switch contact. The warning light then comes on to warn the driver of the situation.

The warning light may, although momentarily, illuminate even when the brake fluid level is normal if the vehicle tilts or swing largely.

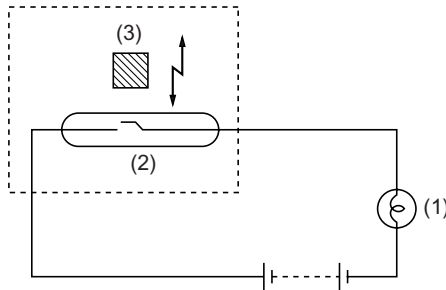

BR-00147

(1) Warning light

(2) Reed switch

(3) Permanent magnet

BRAKE BOOSTER

BRAKE

3. Brake Booster

The brake booster is a tandem type that uses two diaphragms.

By utilizing the differential pressure between the intake manifold vacuum and atmospheric pressure, a high braking force can be obtained even when the pedal depressing effort is small.

The brake booster is installed between the brake pedal and master cylinder. This contributes to improve the response to the brake pedal. If it fails, the brake servo effect is lost requiring a larger pedal effort, however, the braking force is still maintained.

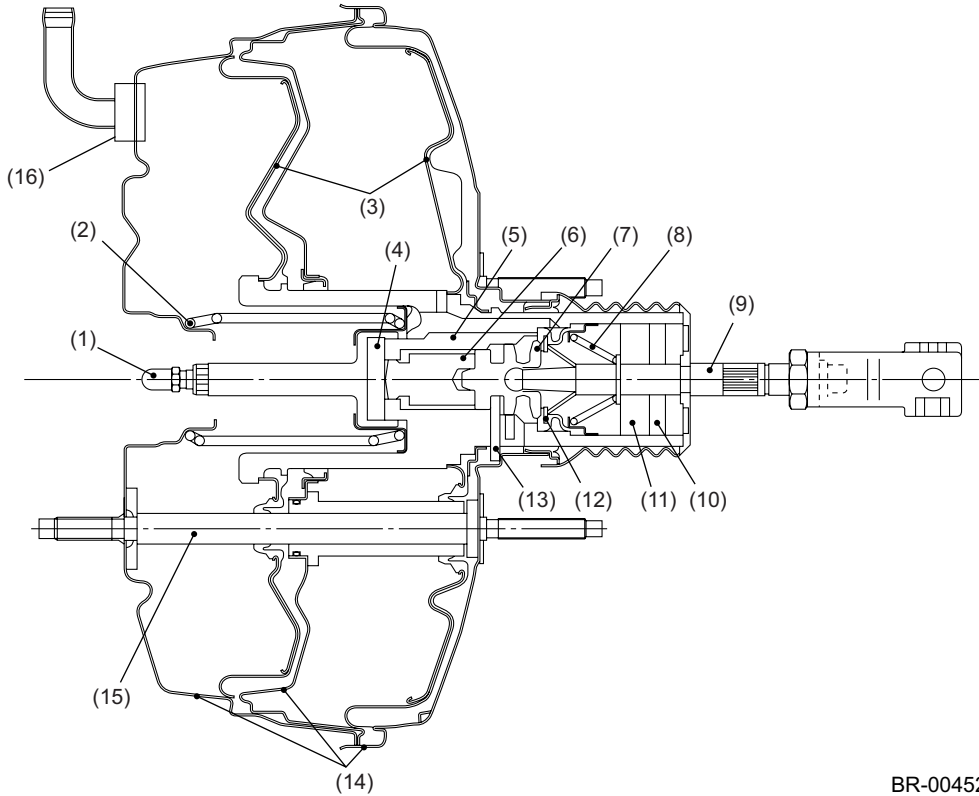

BR-00452

- | | | |
|---------------------|-------------------|-----------------------------|
| (1) Output rod | (7) Plunger valve | (13) Stop plate |
| (2) Return spring | (8) Valve spring | (14) Shell |
| (3) Diaphragm | (9) Input rod | (15) Tie-rod (through bolt) |
| (4) Reaction disc | (10) Silencer | (16) Check valve |
| (5) Control housing | (11) Filter | |
| (6) Piston | (12) Poppet seal | |

4. Brake Pedal

The brake pedal is provided with a mechanism to control movement to the rear in case of a frontal collision to minimize injury to the driver's legs.

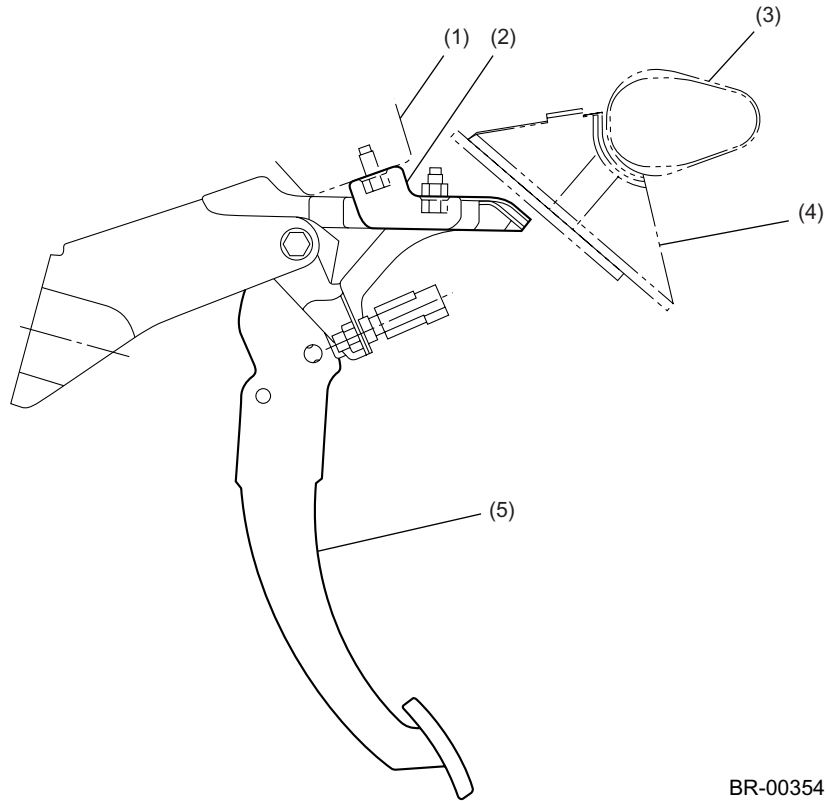

BR-00354

- (1) Mounting bracket at body side
- (2) Bracket at brake pedal side
- (3) Steering support beam

- (4) Brake pedal catcher
- (5) Brake pedal assembly

BRAKE PEDAL

BRAKE

If the brake pedal is pushed rearwards in case of a frontal collision, the brake pedal comes in contact with the catcher.

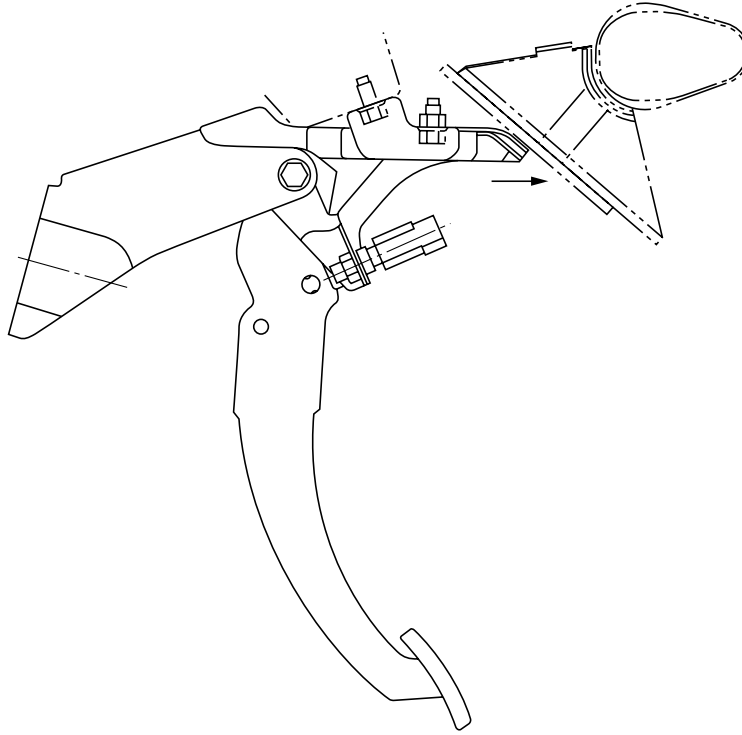

BR-00355

If the brake pedal is pressed further, the brake pedal will come apart from the pedal side bracket. The brake pedal will move along the brake catcher.

By letting the brake pedal to move down along the catcher, the rearward movement of the brake pad is controlled.

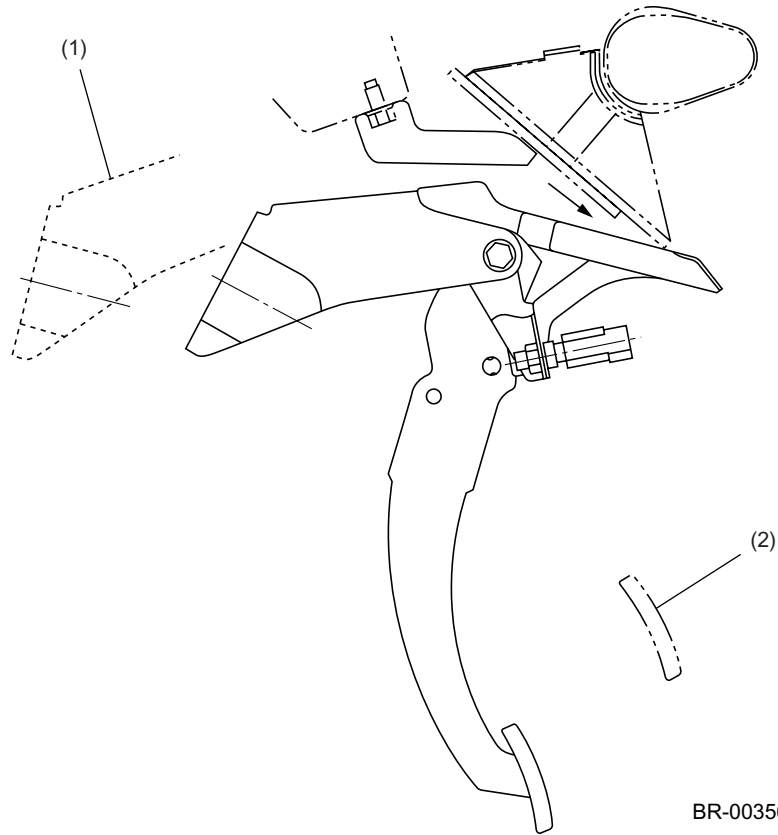

BR-00356

- (1) Mounted position before collision
- (2) Brake pedal pad position after a collision on a vehicle without a rearward movement control mechanism