

Brought to you by Eris Studios  
NOT FOR RESALE

# **EMISSION CONTROL**

## **(AUX. EMISSION CONTROL DEVICES)**

## SYSTEM OVERVIEW

EMISSION CONTROL (AUX. EMISSION CONTROL DEVICES)

---

### 1. System Overview

There are three emission control systems, which are as follows:

- Crankcase emission control system
- Exhaust emission control system
  - Catalytic converter
  - Air/fuel (A/F) control system
  - Ignition control system
  - Exhaust gas recirculation system
- Evaporative emission control system
  - On-board refueling vapor recovery (ORVR) system

Brought to you by Eris Studios  
NOT FOR RESALE

# SYSTEM OVERVIEW

## EMISSION CONTROL (AUX. EMISSION CONTROL DEVICES)

Item		Main components	Function
Crankcase emission control system		Positive crankcase ventilation (PCV) valve	Draws blow-by gas into intake manifold from crankcase and burn it together with air-fuel mixture. Amount of blow-by gas to be drawn in is controlled by intake manifold pressure.
Exhaust emission control system	Catalytic converter	Front	Oxidizes HC and CO contained in exhaust gases as well as reducing NOx.
		Rear	
	Air/fuel (A/F) control system	Engine control module (ECM)	Receives input signals from various sensors, compares signals with stored data, and emits a signal for optimal control of air-fuel mixture ratio.
		Front oxygen (A/F) sensor	Detects density of oxygen contained exhaust gases.
		Front oxygen sensor Rear oxygen sensor	Detects density of oxygen contained in exhaust gases.
		Throttle position sensor	Detects throttle opening.
		Manifold absolute pressure sensor	Detects absolute pressure of intake manifold.
		Mass air flow and intake air temperature sensor	Detects amount of intake air.
			Detects intake air temperature at air cleaner case.
	Ignition control system	ECM	Receives various signals, compares signals with basic data stored in memory, and emits a signal for optimal control of ignition timing.
		Crankshaft position sensor	Detects engine speed (revolution).
		Camshaft position sensor	Detects reference signal for combustion cylinder discrimination.
		Engine coolant temperature sensor	Detects coolant temperature.
		Knock sensor	Detects engine knocking.
Exhaust gas recirculation system	EGR valve	Adjusts the amount of exhaust gas flowing back to the intake pipe.	
Evaporative emission control system	Canister	Absorbs evaporative gas that accumulates in fuel tank when engine stops, and releases it to combustion chambers for a complete burn when the engine is started. This prevents HC from being discharged into atmosphere.	
	Purge control solenoid valve	Receives a signal from ECM and controls purge of evaporative gas absorbed by canister.	
	Pressure control solenoid valve	Receives a signal from ECM and controls evaporative gas pressure in fuel tank.	
ORVR system	Vent valve	Controls evaporation pressure in the fuel tank.	
	Drain valve	Closes the evaporation line by receiving a signal from ECM to check the evaporation gas leak.	

# SCHEMATIC DIAGRAMS

EMISSION CONTROL (AUX. EMISSION CONTROL DEVICES)

## 2. Schematic Diagrams

- Type 1

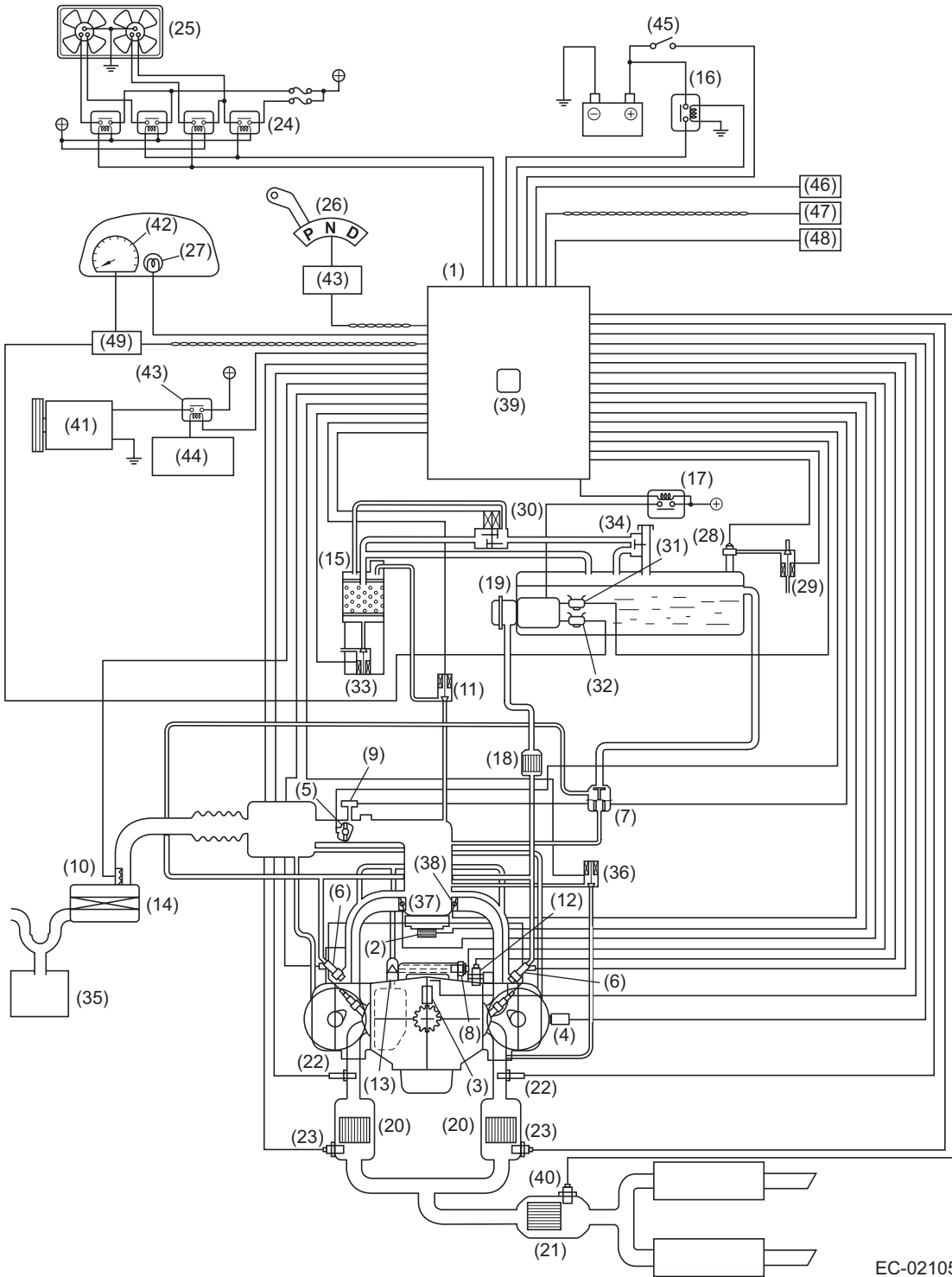

EC-02105

EC(H4SO)-4

# **SCHEMATIC DIAGRAMS**

## **EMISSION CONTROL (AUX. EMISSION CONTROL DEVICES)**

---

- |  |  |   |
|--|--|---|
| (1) Engine control module (ECM)                      | (18) Fuel filter                       | (35) Resonator chamber                                  |
| (2) Ignition coil and igniter assembly               | (19) Fuel pump                         | (36) EGR valve  |
| (3) Crankshaft position sensor                       | (20) Front catalytic converter         | (37) Tumble generator valve actuator                    |
| (4) Camshaft position sensor                         | (21) Rear catalytic converter          | (38) Tumble generator valve position sensor             |
| (5) Electronic control throttle                      | (22) Front oxygen (A/F) sensor         | (39) Atmospheric pressure sensor                        |
| (6) Fuel injector                                    | (23) Front oxygen sensor               | (40) Rear oxygen sensor                                 |
| (7) Pressure regulator                               | (24) Radiator fan relay                | (41) A/C compressor                                     |
| (8) Engine coolant temperature sensor                | (25) Radiator fan                      | (42) Tachometer   |
| (9) Manifold absolute pressure sensor                | (26) Inhibitor switch (AT models only) | (43) A/C relay  |
| (10) Mass air flow and intake air temperature sensor | (27) Engine warning light              | (44) A/C control module                                 |
| (11) Purge control solenoid valve                    | (28) Fuel tank pressure sensor         | (45) Ignition switch                                    |
| (12) Knock sensor                                    | (29) Fuel tank sensor control valve    | (46) Transmission control module (TCM) (AT models only) |
| (13) PCV valve                                       | (30) Pressure control solenoid valve   | (47) ABS control module (ABSCM)                         |
| (14) Air cleaner element                             | (31) Fuel temperature sensor           | (48) Data link connector                                |
| (15) Canister  | (32) Fuel level sensor                 | (49) Body integrated unit                               |
| (16) Main relay                                      | (33) Drain valve                       |   |
| (17) Fuel pump relay                                 | (34) Shut-off valve                    |   |

# SCHEMATIC DIAGRAMS

## EMISSION CONTROL (AUX. EMISSION CONTROL DEVICES)

- Type 2

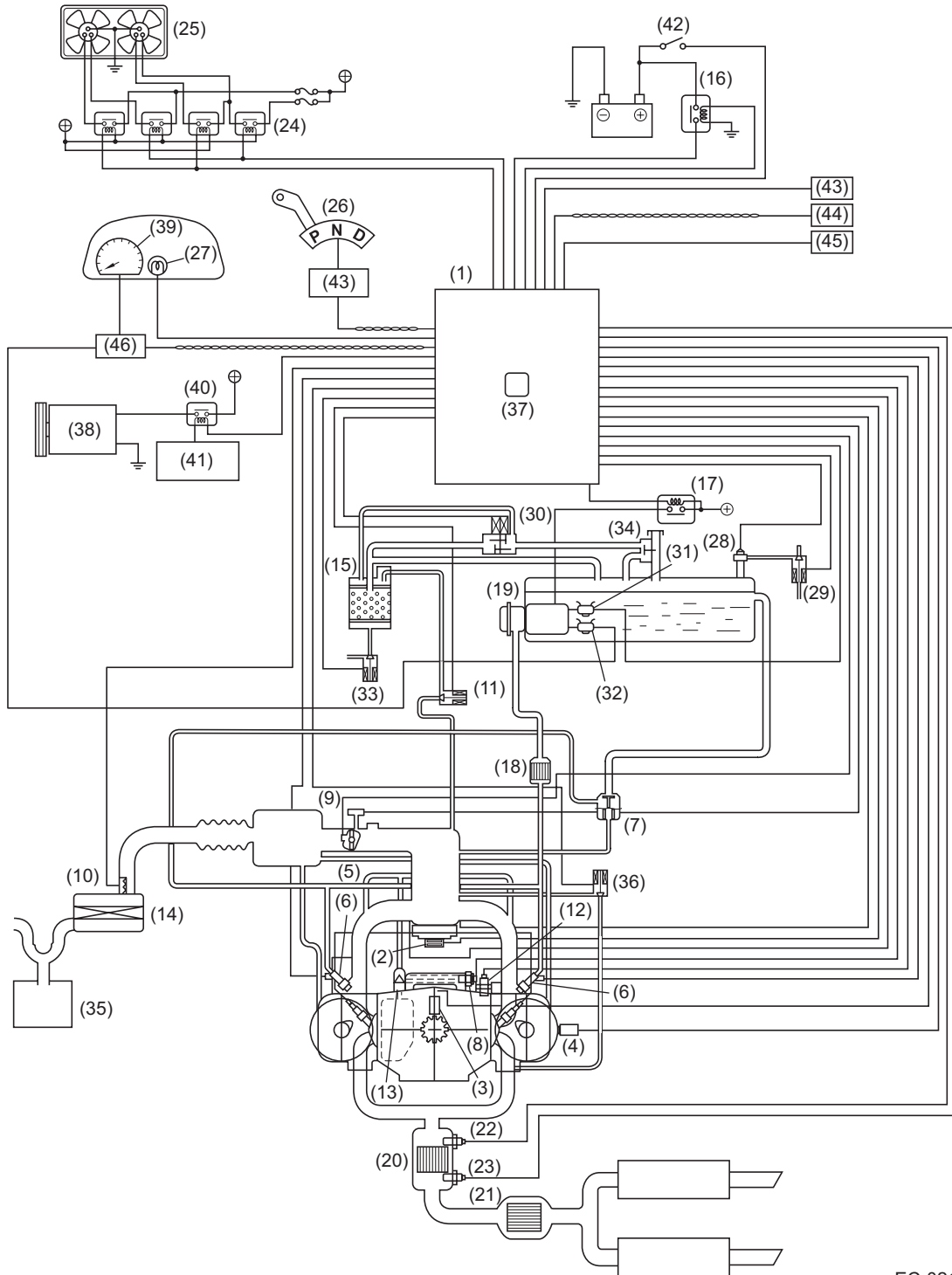

EC-02106

# **SCHEMATIC DIAGRAMS**

## **EMISSION CONTROL (AUX. EMISSION CONTROL DEVICES)**

---

- |  |  |   |
|--|--|---|
| (1) Engine control module (ECM)                      | (17) Fuel pump relay                   | (33) Drain valve  |
| (2) Ignition coil and igniter assembly               | (18) Fuel filter                       | (34) Shut-off valve                                     |
| (3) Crankshaft position sensor                       | (19) Fuel pump                         | (35) Resonator chamber                                  |
| (4) Camshaft position sensor                         | (20) Front catalytic converter         | (36) EGR valve  |
| (5) Electronic control throttle                      | (21) Rear catalytic converter          | (37) Atmospheric pressure sensor                        |
| (6) Fuel injector                                    | (22) Front oxygen (A/F) sensor         | (38) A/C compressor                                     |
| (7) Pressure regulator                               | (23) Rear oxygen sensor                | (39) Tachometer   |
| (8) Engine coolant temperature sensor                | (24) Radiator fan relay                | (40) A/C relay  |
| (9) Manifold absolute pressure sensor                | (25) Radiator fan                      | (41) A/C control module                                 |
| (10) Mass air flow and intake air temperature sensor | (26) Inhibitor switch (AT models only) | (42) Ignition switch                                    |
| (11) Purge control solenoid valve                    | (27) Engine warning light              | (43) Transmission control module (TCM) (AT models only) |
| (12) Knock sensor                                    | (28) Fuel tank pressure sensor         | (44) ABS control module (ABSCM)                         |
| (13) PCV valve                                       | (29) Fuel tank sensor control valve    | (45) Data link connector                                |
| (14) Air cleaner element                             | (30) Pressure control solenoid valve   | (46) Body integrated unit                               |
| (15) Canister  | (31) Fuel temperature sensor           |   |
| (16) Main relay                                      | (32) Fuel level sensor                 |   |

# CRANKCASE EMISSION CONTROL SYSTEM

EMISSION CONTROL (AUX. EMISSION CONTROL DEVICES)

## 3. Crankcase Emission Control System

- The positive crankcase ventilation (PCV) system prevents air pollution that will be caused by blow-by gas being emitted from the crankcase. The system consists of a sealed oil filler cap, rocker covers with fresh air inlet, connecting hoses, a PCV valve and an air intake duct.
- In a part-throttle condition, the blow-by gas in the crankcase flows into the intake manifold through the connecting hose of crankcase and PCV valve by the strong vacuum created in the intake manifold. Under this condition, fresh air is introduced into the crankcase through the connecting hose of the rocker cover.
- In a wide-open-throttle condition, a part of blow-by gas flows into the air intake duct through the connecting hose and is drawn into the throttle chamber, because under this is condition, the intake manifold vacuum is not strong enough to introduce through the PCV valve all blow-by gases that increase in the amount with engine speed.

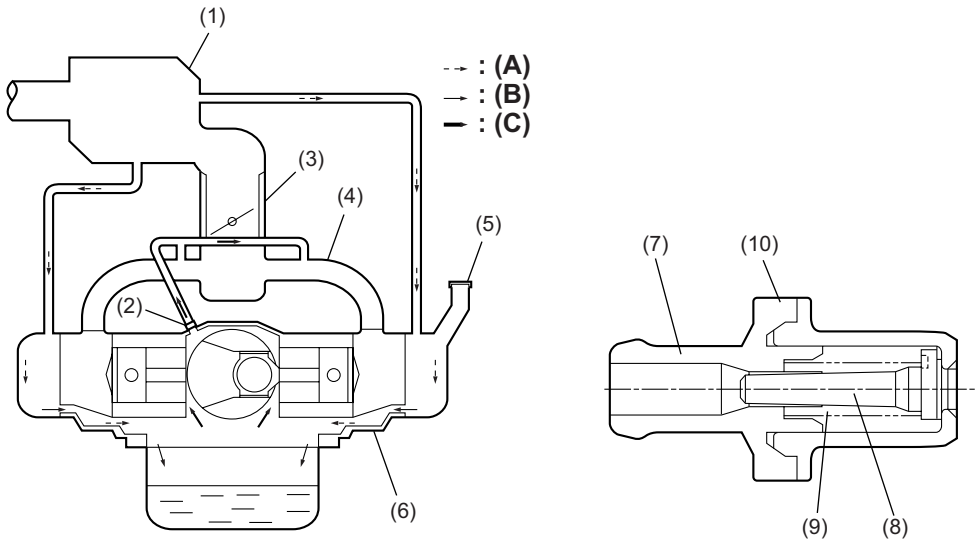

EC-02107

- |                        |                |                                    |
|------------------------|----------------|------------------------------------|
| (1) Air intake chamber | (6) Crankcase  | (A) Outside air                    |
| (2) PCV valve          | (7) Case       | (B) Mixture of air and blow-by gas |
| (3) Throttle body      | (8) Valve      | (C) Blow-by gas                    |
| (4) Intake manifold    | (9) Spring     |                                    |
| (5) Oil filler cap     | (10) PCV valve |                                    |



## CATALYTIC CONVERTER

EMISSION CONTROL (AUX. EMISSION CONTROL DEVICES)

---

### 4. Catalytic Converter

- The basic materials of the three-way catalytic converter are platinum (Pt), rhodium (Rh) and palladium (Pd), and a thin coat of their mixture is applied onto a honeycomb or porous ceramic (carrier). To avoid damaging the catalytic converter, only unleaded gasoline should be used.
- The catalytic converter reduces HC, CO and NO<sub>x</sub> in exhaust gases through chemical reactions (oxidation and reduction). These harmful components are reduced most efficiently when their concentrations are in a certain balance. These concentrations vary with the air-fuel ratio. The ideal air-fuel ratio for reduction of these components is the stoichiometric ratio.
- Therefore, the air-fuel ratio needs to be controlled to around the stoichiometric ratio to purify the exhaust gases most efficiently.

## AIR/FUEL (A/F) CONTROL SYSTEM

EMISSION CONTROL (AUX. EMISSION CONTROL DEVICES)

---

### 5. Air/fuel (A/F) Control System

- The air/fuel (A/F) control system makes a correction to the basic fuel injection duration in accordance with the signals from the front oxygen (A/F) sensor and the rear oxygen sensor so that the stoichiometric ratio is maintained, thus ensuring most effective exhaust gas purification by the three-way catalytic converter. Different basic fuel injection durations are preset for various engine speeds and loads, as well as the amount of intake air.
- This system also has a learning control function which stores the corrected data in relation to the basic fuel injection in the memory map. This allows an appropriate air-fuel ratio correction to be added automatically in quick response to any situation that requires such an effect. Thus, the air-fuel ratio is optimally maintained under various conditions while purifying exhaust gases most effectively, improving driving performance and compensating for changes in sensors' performance over time.

# AIR/FUEL (A/F) CONTROL SYSTEM

EMISSION CONTROL (AUX. EMISSION CONTROL DEVICES)

---

MEMO

# IGNITION CONTROL SYSTEM

EMISSION CONTROL (AUX. EMISSION CONTROL DEVICES)

## 6. Ignition Control System

- The ignition system is controlled by the ECM.

The ECM monitors the operating condition of the engine using the signals from the sensors and switches shown below and determines the ignition timing most appropriate for each engine operating condition. Then it sends a signal to the igniter, commanding generation of a spark at that timing.

- The ECM uses a preprogrammed map for a “closed-loop” control which provides its ignition timing control with excellent transient characteristics, i.e., highly responsive ignition timing control.

- Type 1

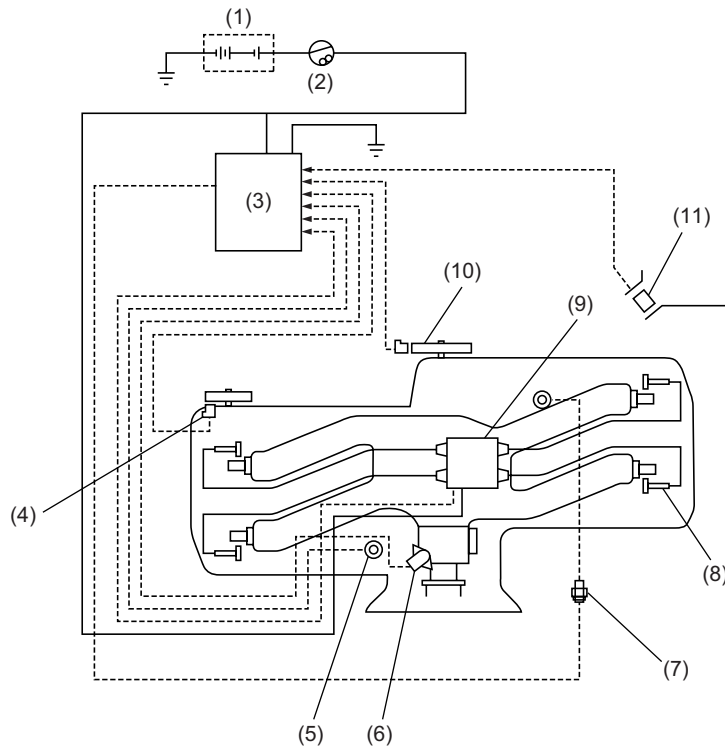

EC-02091

- |                                       |  |
|---------------------------------------|--|
| (1) Battery                           | (7) Engine coolant temperature sensor                |
| (2) Ignition switch                   | (8) Spark plug                                       |
| (3) ECM                               | (9) Ignition coil and igniter assembly               |
| (4) Camshaft position sensor          | (10) Crankshaft position sensor                      |
| (5) Knock sensor                      | (11) Mass air flow and intake air temperature sensor |
| (6) Manifold absolute pressure sensor |  |

# IGNITION CONTROL SYSTEM

EMISSION CONTROL (AUX. EMISSION CONTROL DEVICES)

- Type 2

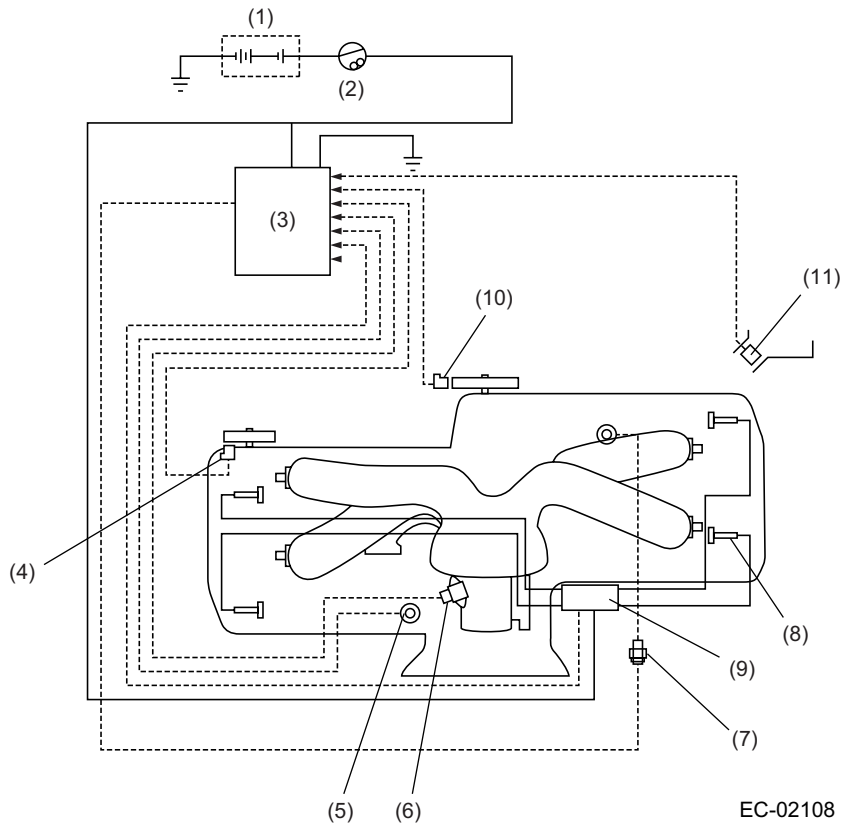

- |                                       |  |
|---------------------------------------|--|
| (1) Battery                           | (7) Engine coolant temperature sensor                |
| (2) Ignition switch                   | (8) Spark plug                                       |
| (3) ECM                               | (9) Ignition coil and igniter assembly               |
| (4) Camshaft position sensor          | (10) Crankshaft position sensor                      |
| (5) Knock sensor                      | (11) Mass air flow and intake air temperature sensor |
| (6) Manifold absolute pressure sensor |  |

# EXHAUST GAS RECIRCULATION (EGR) SYSTEM

EMISSION CONTROL (AUX. EMISSION CONTROL DEVICES)

## 7. Exhaust Gas Recirculation (EGR) System

### 1. GENERAL

- The EGR system aims at reduction of NO<sub>x</sub> by lowering the combustion temperature through re-circulation of a part of exhaust gas into cylinders via the intake manifold.
- The EGR valve is controlled by the ECM according to the engine operating condition.

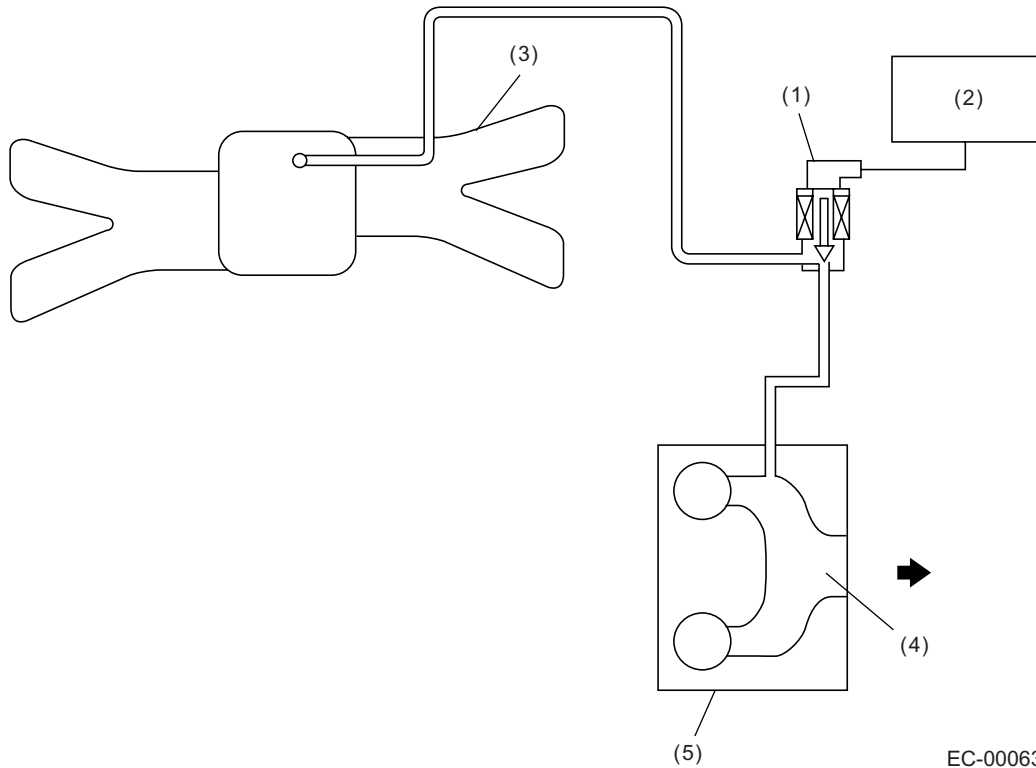

- (1) EGR valve
- (2) ECM
- (3) Intake manifold

- (4) Exhaust port
- (5) Cylinder head LH

# EVAPORATIVE EMISSION CONTROL SYSTEM

EMISSION CONTROL (AUX. EMISSION CONTROL DEVICES)

## 8. Evaporative Emission Control System

### A: GENERAL

- The evaporative emission control system prevents fuel vapors from escaping into atmosphere. This system includes a canister, purge control solenoid valve, fuel cut valve, and the lines connecting them.
- Fuel vapor in the fuel tank is introduced into the canister through the evaporation line, and are absorbed by activated carbon in it. The fuel cut valve is also incorporated in the fuel tank line.
- The purge control solenoid valve is controlled optimally by the ECM according to the engine condition.
- The pressure control solenoid valve incorporated in the fuel tank evaporation line regulates the pressure/vacuum in the fuel tank under the control of the ECM which uses the signal from the fuel tank pressure sensor.

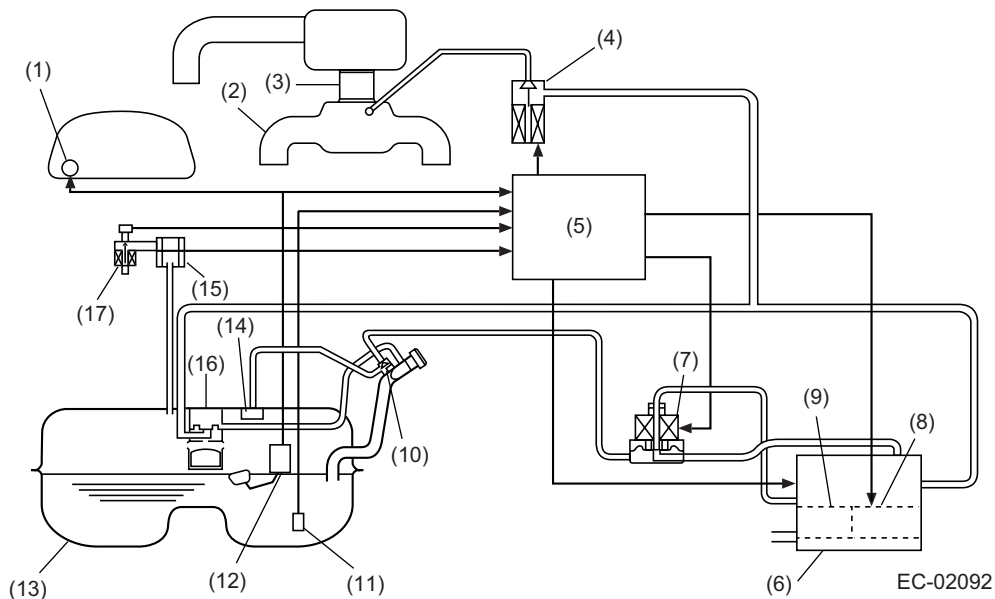

- |                                  |                                     |                                     |
|----------------------------------|-------------------------------------|-------------------------------------|
| (1) Fuel gauge                   | (7) Pressure control solenoid valve | (13) Fuel tank                      |
| (2) Intake manifold              | (8) Drain valve                     | (14) Fuel cut valve                 |
| (3) Throttle body                | (9) Drain filter                    | (15) Fuel tank pressure sensor      |
| (4) Purge control solenoid valve | (10) Shut-off valve                 | (16) Vent valve                     |
| (5) Engine control module (ECM)  | (11) Fuel temperature sensor        | (17) Fuel tank sensor control valve |
| (6) Canister                     | (12) Fuel level sensor              |                                     |

### B: FUEL CUT VALVE

The fuel cut valve is incorporated in the fuel tank. The rising level of the fuel in the fuel tank causes the float to move up and close the cap hole so that no fuel can flow to the evaporation line.

# EVAPORATIVE EMISSION CONTROL SYSTEM

EMISSION CONTROL (AUX. EMISSION CONTROL DEVICES)

## C: FUEL TANK CAP

- The fuel tank cap is of a quick lock type and can be opened or closed in 1/4 of a full turn.
- The fuel tank cap has a relief valve, which prevents development of vacuum in the fuel tank in the event of a problem with the fuel vapor line.

When there is no problem with the fuel vapor line, the filler pipe is sealed at the portion (A) and by the seal pressed against the filler pipe end. If vacuum develops in the fuel tank, the atmospheric pressure forces the spring down to open the valve; consequently outside air flows into the fuel tank, thus controlling the inside pressure.

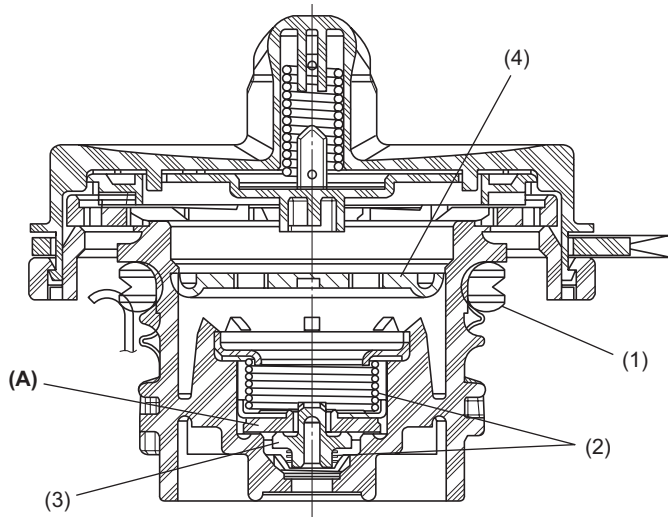

EC-02109

- (1) Seal
- (2) Spring
- (3) Valve
- (4) Filter



# EVAPORATIVE EMISSION CONTROL SYSTEM

EMISSION CONTROL (AUX. EMISSION CONTROL DEVICES)

## D: CANISTER

The canister incorporates a drain valve and a drain filter.

The charcoal filled in the canister temporarily stores fuel vapors. When the purge control solenoid valve is opened by a signal from the ECM, the external fresh air entering the canister carries the fuel vapors into the collector chamber.

The drain filter is installed at the air inlet port of the drain valve. It cleans the air taken in the canister through the drain valve.

The drain valve is located just below the drain filter.

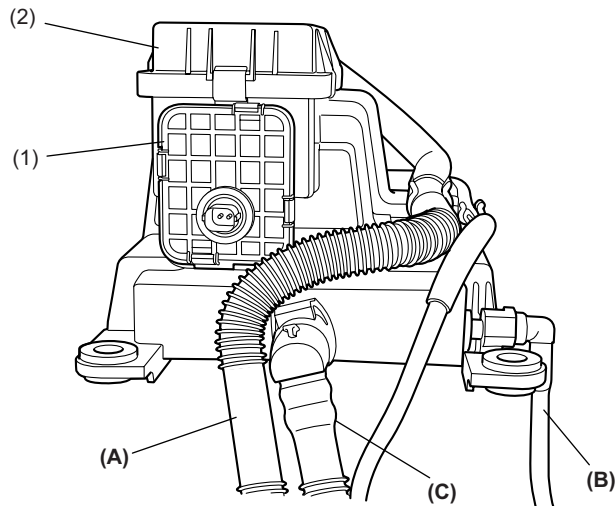

EC-02093

- (1) Drain valve
- (2) Drain filter

- (A) Air
- (B) To pressure control solenoid valve
- (C) From fuel tank

# EVAPORATIVE EMISSION CONTROL SYSTEM

EMISSION CONTROL (AUX. EMISSION CONTROL DEVICES)

## E: PURGE CONTROL SOLENOID VALVE

The purge control solenoid valve is on the evaporation line between the canister and intake manifold. The valve is installed under the intake manifold.

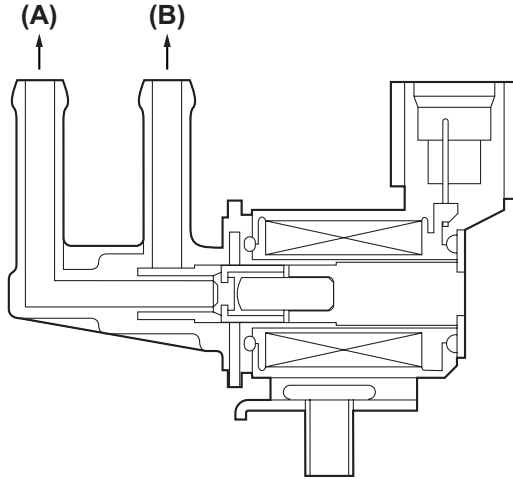

EC-00237

- (A) To intake manifold
- (B) To canister

# EVAPORATIVE EMISSION CONTROL SYSTEM

EMISSION CONTROL (AUX. EMISSION CONTROL DEVICES)

## F: PRESSURE CONTROL SOLENOID VALVE

The fuel tank pressure control solenoid valve is located in the evaporation line between the canister and the fuel tank.

When the tank inside pressure becomes higher than the atmospheric pressure, the valve is opened allowing fuel vapors to be introduced into the canister.

On the other hand, when the tank inside pressure becomes lower than the atmospheric pressure, external air is taken from the drain valve into the canister.

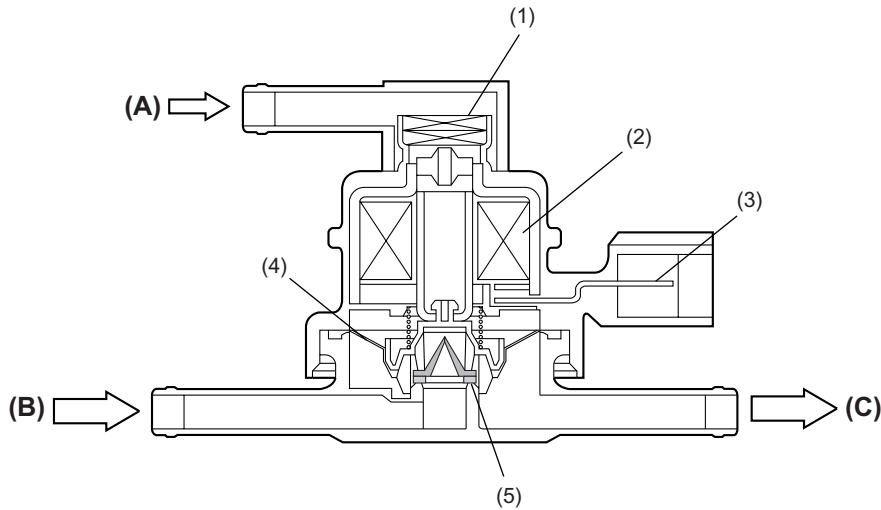

EC-00026

- |                        |                          |
|------------------------|--------------------------|
| (1) Filter             | (A) Atmospheric pressure |
| (2) Coil               | (B) Shut-off valve       |
| (3) Connector terminal | (C) To fuel tank         |
| (4) Diaphragm          |                          |
| (5) Valve              |                          |

## G: VENT VALVE

The vent valve is incorporated in the fuel tank. During filling the fuel tank, fuel vapors are introduced into the canister through the vent valve.

When the fuel vapor pressure becomes higher than the atmospheric pressure and overcomes the spring force which is applied to the back side of the diaphragm, the port toward the canister is opened. The vent valve also has a float which rises and block the port toward the canister when the fuel is full.

# EVAPORATIVE EMISSION CONTROL SYSTEM

EMISSION CONTROL (AUX. EMISSION CONTROL DEVICES)

## H: SHUT-OFF VALVE

The shut-off valve is located at the top of the fuel filler pipe. When a filler gun is inserted into the filler pipe, the shut-off valve closes the evaporation line.

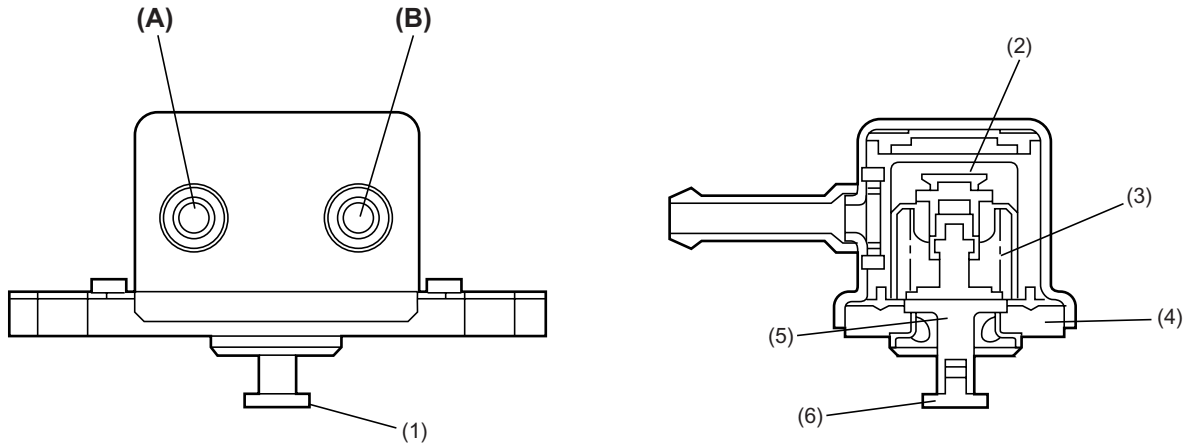

EC-00029

- (1) Pin
- (2) Valve
- (3) Spring
- (4) Plate
- (5) Shaft
- (6) Pin
- (A) To canister
- (B) To fuel tank

## I: FUEL TANK SENSOR CONTROL VALVE

The fuel tank sensor control valve is installed on the top of the fuel tank and its one end is connected to the fuel tank pressure sensor while its other end is open to the atmosphere.

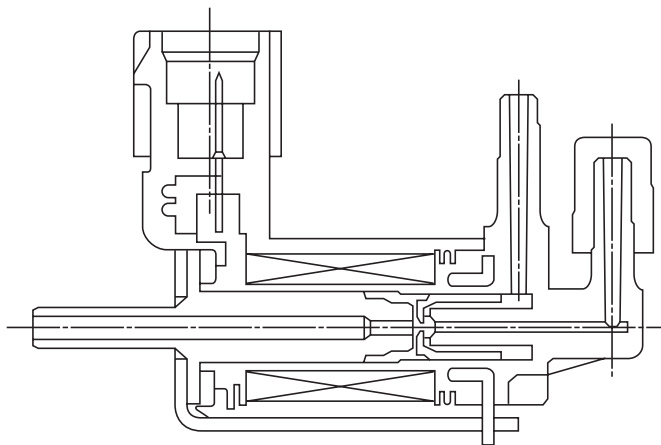

EC-00031

EC(H4SO)-20

# EVAPORATIVE EMISSION CONTROL SYSTEM

EMISSION CONTROL (AUX. EMISSION CONTROL DEVICES)

## J: FUEL TANK PRESSURE SENSOR

The fuel tank pressure sensor is installed on the top of the fuel tank and measures the pressure in the fuel tank.

The measured pressure is converted into an electrical signal and sent to the ECM for diagnosis of the evaporative emission control system.

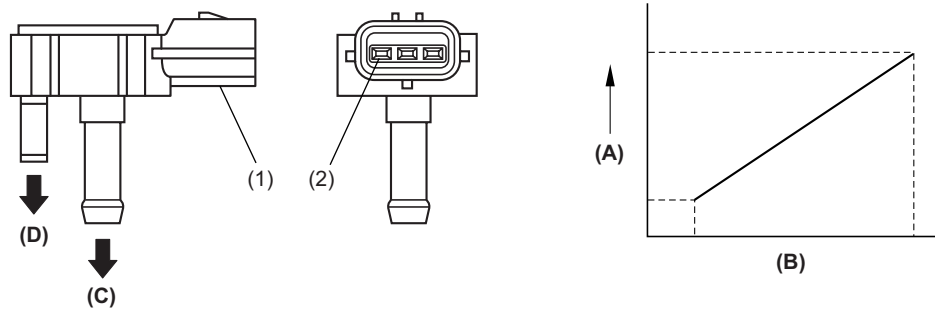

EC-02110

- (1) Connector
- (2) Terminal

- (A) Output voltage
- (B) Input pressure
- (C) To fuel tank
- (D) To fuel tank sensor control valve

# ON-BOARD REFUELING VAPOR RECOVERY (ORVR) SYSTEM

EMISSION CONTROL (AUX. EMISSION CONTROL DEVICES)

## 9. On-board Refueling Vapor Recovery (ORVR) System

### A: GENERAL

The on-board refueling vapor recovery system allows the fuel vapors in the fuel tank to be introduced directly into the canister through the vent valve when the fuel tank inside pressure increases as a result of refueling.

The diagnosis of the system is performed by monitoring the fuel tank inside pressure data from the fuel tank pressure sensor while forcibly closing the drain valve.

### B: OPERATION

- While driving

Since the back side of the diaphragm in the pressure control solenoid valve is open to the atmosphere, the diaphragm is held pressed by the atmospheric pressure in the position where only the external air is introduced into the canister. When the fuel vapor pressure acting on the other side of the diaphragm increases and overcomes the atmospheric pressure, it pushes the diaphragm and opens the port through which the fuel vapors make their way to the canister.

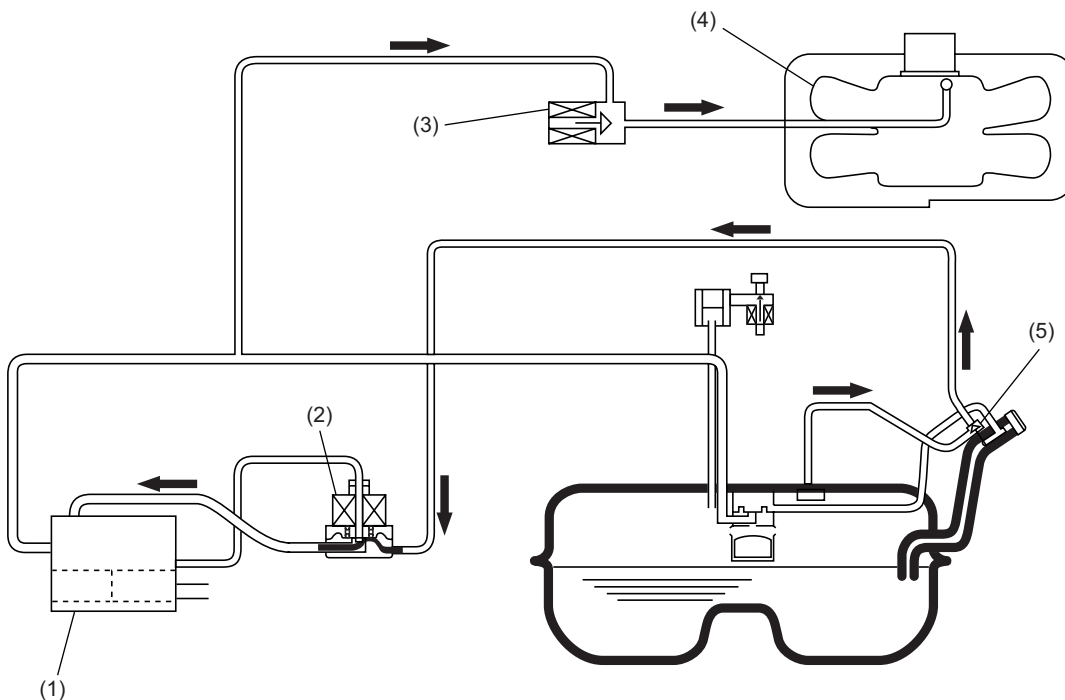

EC-02094

- |                                     |                          |
|-------------------------------------|--------------------------|
| (1) Canister                        | (4) Intake manifold      |
| (2) Pressure control solenoid valve | (5) Shut-off valve: open |
| (3) Purge control solenoid valve    |                          |

# ON-BOARD REFUELING VAPOR RECOVERY (ORVR) SYSTEM

EMISSION CONTROL (AUX. EMISSION CONTROL DEVICES)

- While refueling

As the fuel enters the fuel tank, the tank inside pressure increases. When the inside pressure becomes higher than the atmospheric pressure, the port of the vent valve opens, allowing the fuel vapors to be introduced into the canister through the vent line. The fuel vapors are absorbed by charcoal in the canister, so the air discharged from the drain valve contains no fuel. When a filler gun is inserted, the shut-off valve closes the evaporation line.

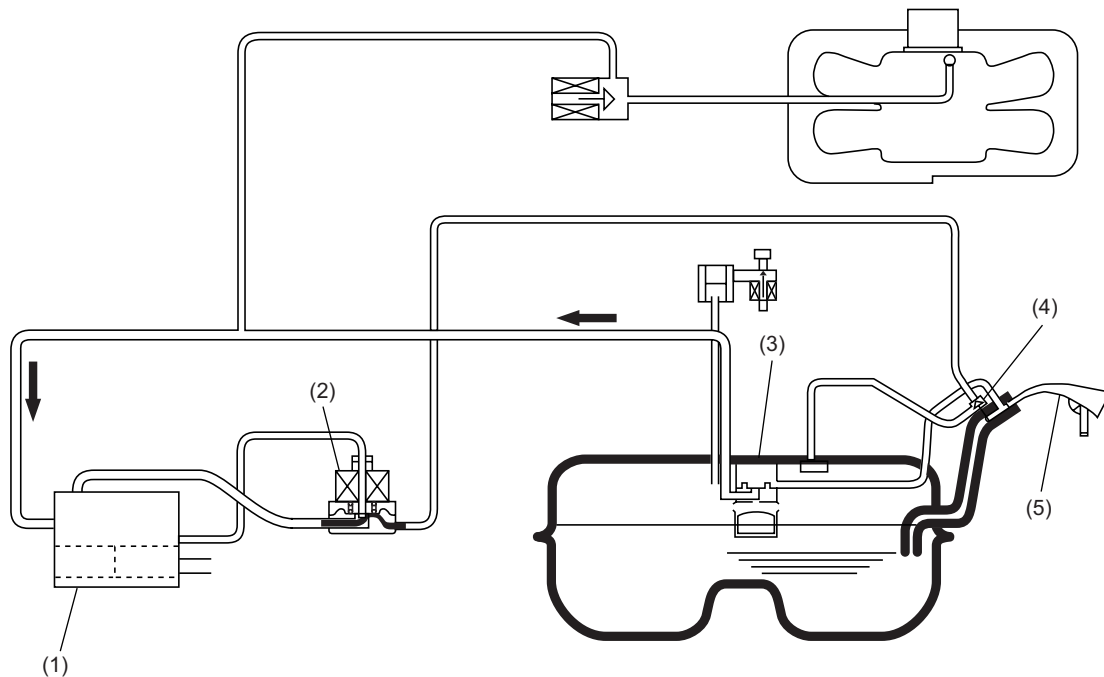

EC-02095

- |                                     |                            |
|-------------------------------------|----------------------------|
| (1) Canister                        | (4) Shut-off valve: closed |
| (2) Pressure control solenoid valve | (5) Filler gun             |
| (3) Vent valve                      |                            |

# VACUUM CONNECTIONS

EMISSION CONTROL (AUX. EMISSION CONTROL DEVICES)

## 10. Vacuum Connections

The hose and pipe connections of the intake manifold and other related parts are as shown in the illustration.

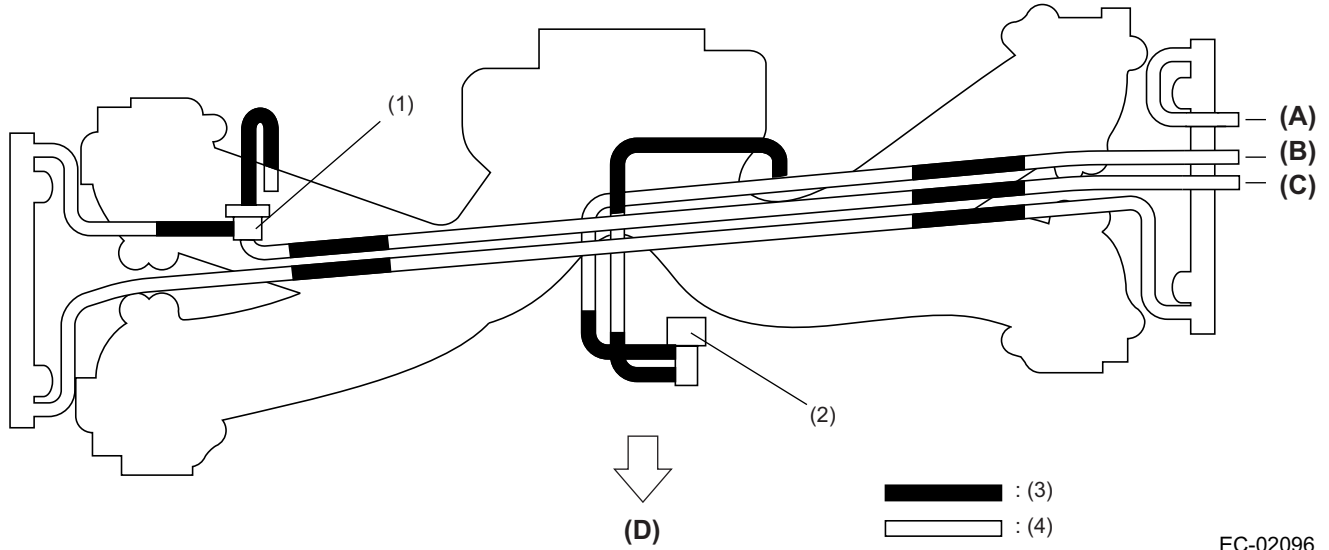

EC-02096