

Brought to you by Eris Studios
NOT FOR RESALE

INSTRUMENTATION DRIVER INFO

COMBINATION METER

INSTRUMENTATION/DRIVER INFO

1. Combination Meter

A: ELECTRO-LUMINESCENT METER

To increase desirability and visibility of the meter, an electro-luminescent meter is used on some models.

- Red LEDs are used for meter rings and needles illumination.
- The brightness of the meter display area can be properly adjusted to meet various conditions.
- An indicator that illuminates when the lighting switch is turned to the next position from OFF is provided.

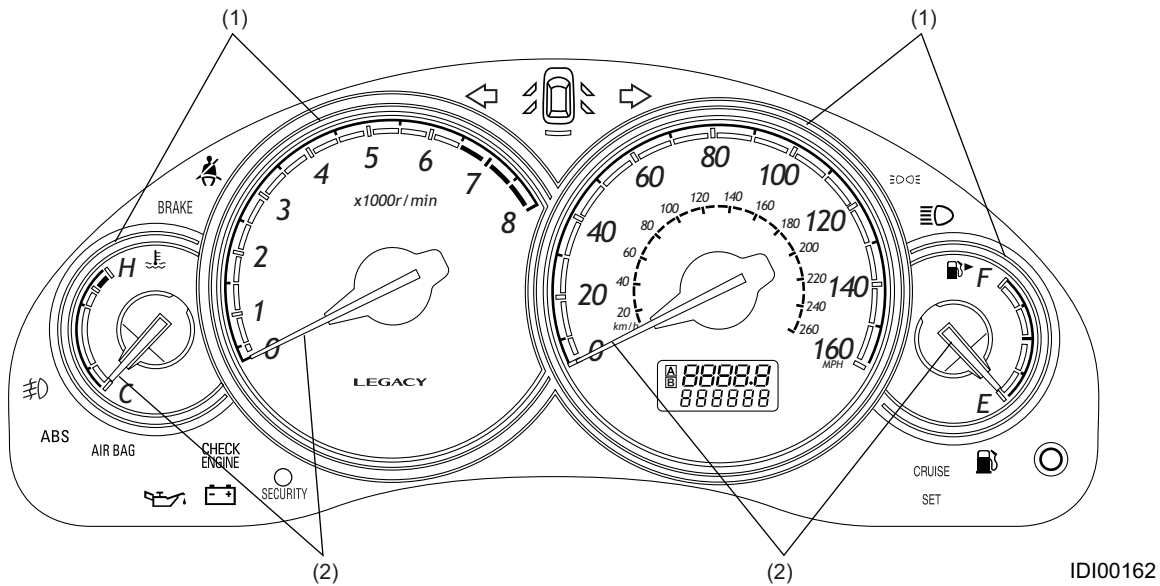

(1) Meter ring

(2) Needle

IDI00162

B: ILLUMINATION AND NEEDLES

1. INITIAL OPERATION

- Electro-luminescent meter

When the ignition switch is turned ON, the meter rings are illuminated first, and the needles are lit next. Then the needle moves from the minimum reading to the maximum reading, and then returns to the minimum reading. Finally the dial illumination and LCD turn on.

- Standard meter

When the ignition switch is turned ON, the meter needle moves from the minimum reading to the maximum reading and then returns to the minimum reading.

The illumination brightness can be adjusted by selecting any of the six steps of the instrument panel dial. (Adjustment is possible only when the lighting switch is ON for the standard meter.)

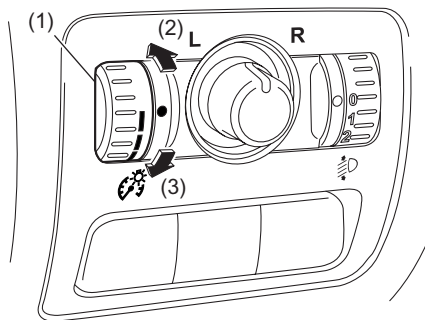

(1) Adjustment dial

(2) Brighter

(3) Darker

COMBINATION METER

INSTRUMENTATION/DRIVER INFO

C: WARNING AND INDICATOR LIGHTS

Brought to you by Eris Studios
NOT FOR RESALE

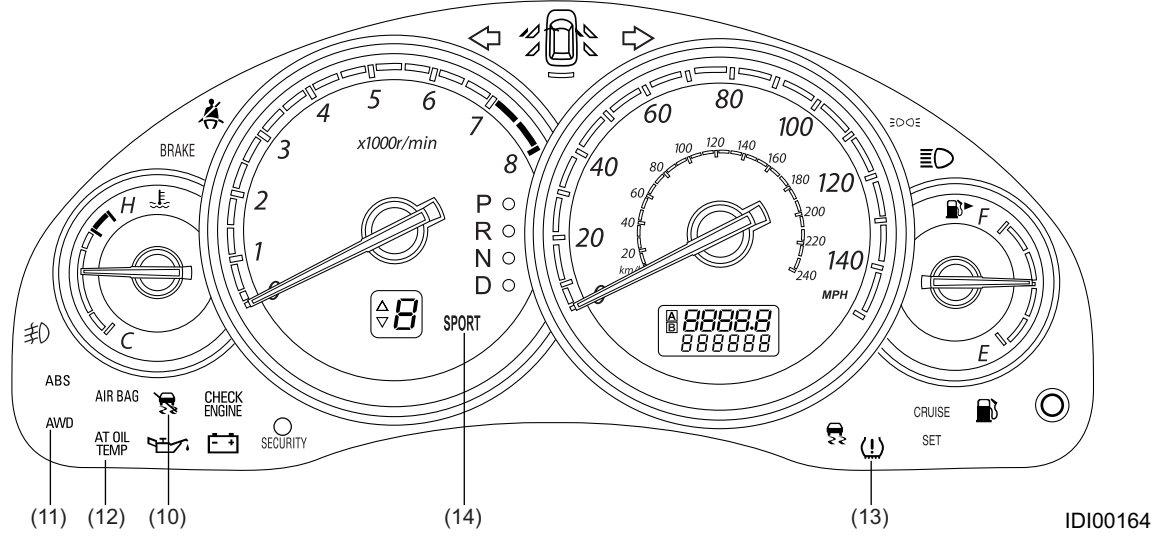
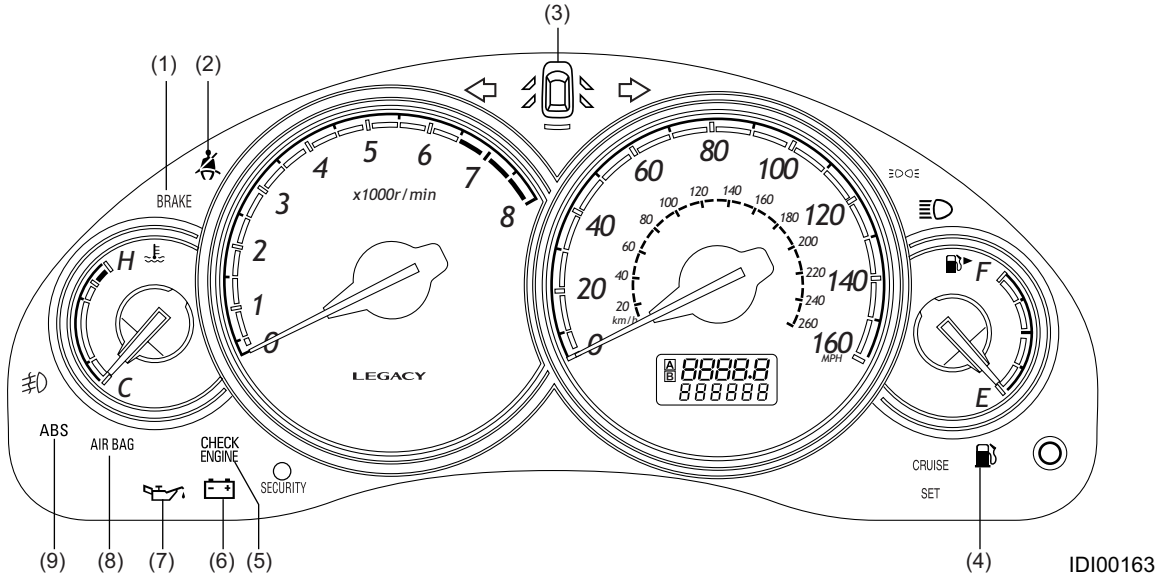

- (1) Brake fluid level warning/parking brake indicator light
This light illuminates if the fluid level in the brake reservoir tank lowers below the specified level and/or when the parking brake is applied.
- (2) Seat belt warning light
This warning light illuminates when the ignition switch is turned ON, and goes out when the seat belt is fastened.
- (3) Door open warning light
This warning light illuminates when one or more doors and/or rear gate are not completely closed.
- (4) Low fuel warning light
This warning light comes ON when the quantity of the fuel remaining in the tank has decreased to 9 ℓ (2.4 US gal, 2.0 Imp gal) or less.
- (5) Engine malfunction indicator light
This light illuminates if a fault occurs in the MFI (Multiple point Fuel Injection) system.
- (6) Charge warning light
This warning light illuminates when a fault occurs in the charging system while the engine is running.
- (7) Oil pressure warning light
This light illuminates when the engine oil pressure decreases below 14.7 kPa (0.15 kgf/cm², 2.1 psi).
- (8) AIR BAG system warning light
This warning light illuminates if a fault occurs in the airbag system.
- (9) ABS warning light
This warning light illuminates if a fault occurs in any electrical component of the ABS (Anti-lock Brake System).
- (10) Vehicle dynamics control warning light and vehicle dynamics control OFF indicator light
This light illuminates when a fault occurs in any electrical component of the vehicle dynamics control. It also illuminates when the vehicle dynamics control OFF switch is pressed.
- (11) AWD warning light (AT)
This warning light illuminates if the vehicle is driven with front and rear tire sizes different from each other. On 4AT models, this indicator illuminates when the drive mode is changed from AWD to FWD (with the fuse installed in the FWD switch).
- (12) AT oil temperature warning light (AT)
This warning light illuminates when the ATF temperature exceeds 150°C (302°F).
- (13) Tire pressure warning light
This warning light illuminates when the air pressure in either of the tires drops below the specified value while traveling, and flashes when a fault occurs in the tire pressure monitoring system.
- (14) Sports mode indicator (AT)
This indicator illuminates when the AT selector lever is put in the sports mode position, and blinks if a fault occurs in the AT control system.

COMBINATION METER

INSTRUMENTATION/DRIVER INFO

When everything is normal, the warning and indicator lights should be ON or OFF as shown below according to ignition switch positions.

Warning/Indicator light		Ignition switch position			
		LOCK/ACC	ON	ST	While engine is running
(1)	Brake fluid level / parking brake	OFF	ON	ON	*1
(2)	Seat belt	OFF	*2	*2	*2
(3)	Door or rear gate open	• Open	ON	ON	ON
		• Closed	OFF	OFF	OFF
(4)	Low fuel level	OFF	*3	*3	*3
(5)	Engine malfunction indicator	OFF	ON	ON	OFF
(6)	Charge	OFF	ON	ON	OFF
(7)	Oil pressure	OFF	ON	ON	OFF
(8)	AIR BAG	OFF	*4	*4	*4
(9)	ABS	OFF	*5	*5	*5
(10)	Vehicle dynamics control	OFF	ON	ON	OFF
(11)	AWD	OFF	*6	*6	*6
(12)	AT oil temperature	OFF	ON	ON	OFF
(13)	Tire pressure	OFF	*5	*5	*5
(14)	Sports mode	OFF	OFF	OFF	*7

*1: This warning light illuminates when the parking brake is applied.

*2: This warning light flashes after the ignition switch is turned ON until the drivers seat belt is fastened.

*3: This warning light illuminates when the quantity of the fuel remaining in the tank has decreased to 9 ℓ (2.4 US gal, 2.0 Imp gal) or less.

*4: This warning light illuminates for about 6 seconds, and then goes out.

*5: This warning light illuminates for about 2 seconds, and then goes out.

*6: This warning light illuminates if the front and rear tire sizes are different from each other. This also illuminates when the drive mode is changed from AWD to FWD (4AT models).

*7: This light illuminates when the AT selector lever is moved to the sports mode position.

COMBINATION METER

INSTRUMENTATION/DRIVER INFO

MEMO

Brought to you by Eris Studios
NOT FOR RESALE

COMBINATION METER

INSTRUMENTATION/DRIVER INFO

D: TELLTALE LIGHT

Brought to you by Eris Studios
NOT FOR RESALE

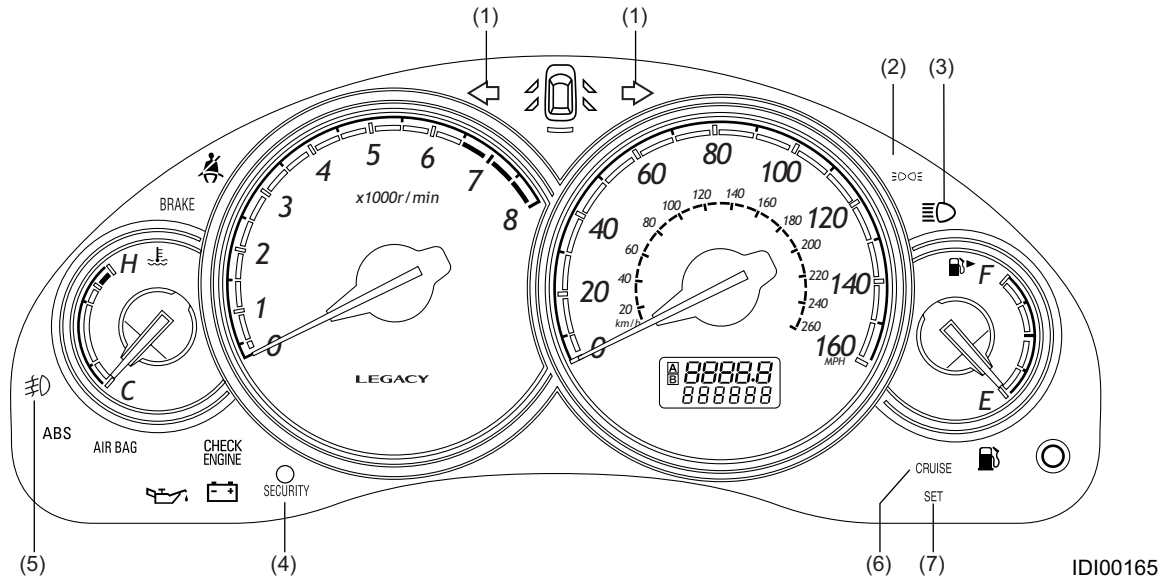

ID100165

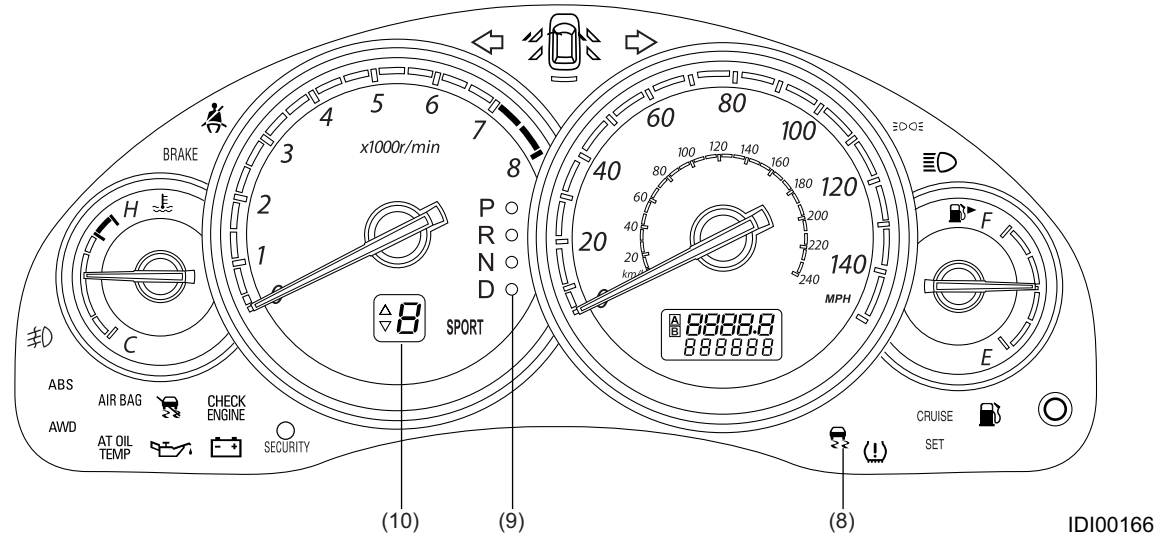

ID100166

COMBINATION METER

INSTRUMENTATION/DRIVER INFO

- (1) Turn signal indicator light
This light blinks in unison with the corresponding turn signal lights when the turn signal switch is operated.
- (2) Lighting switch indicator light
Turns on when the lighting switch is turned to the next position from OFF.
- (3) Headlight beam indicator
This light illuminates when the headlights are in the high-beam position.
- (4) Immobilizer indicator
This light illuminates when the immobilizer systems are armed.
- (5) Front fog light indicator light
This light illuminates when the front fog lights are ON.
- (6) CRUISE indicator light
This light illuminates when the cruise control main switch is turned ON.
- (7) SET indicator light
This light illuminates when the cruise control main switch is turned ON and the SET/COAST switch on the command switch is turned ON.
- (8) Vehicle dynamics control function indicator light
This light blinks when the vehicle dynamics control is operating.
- (9) AT selector lever position indicator (AT)
The indicator corresponding to the present AT select lever position illuminates when the ignition switch is in any position other than ACC and LOCK.
- (10) Sports shift indicator (AT)
Indicates the current gear position when sports shift is selected.

COMBINATION METER

INSTRUMENTATION/DRIVER INFO

When everything is normal, the telltales should be ON, OFF or in other states as shown below according to ignition switch position.

Telltale light		Ignition switch position			
		LOCK/ACC	ON	ST	While engine is running
(1)	Turn signal	OFF	Blink	Blink	Blink
(2)	Lighting switch	OFF	*1	*1	*1
(3)	Headlight beam	● High beam	OFF	ON	ON
		● Low beam	OFF	OFF	OFF
(4)	Immobilizer	*2	OFF	OFF	OFF
(5)	Front fog light	Front fog light ON	OFF	ON	ON
(6)	CRUISE	OFF	OFF	OFF	ON
(7)	SET	OFF	OFF	OFF	*3
(8)	Vehicle dynamics control	OFF	*4	ON	OFF
(9)	AT selector lever position	OFF	ON	ON	ON
(10)	Sports shift indicator	OFF	*5	OFF	*5

*1: Turns on when the lighting switch is turned to the next position from OFF.

*2: This light illuminates when the immobilizer system is armed.

*3: This light illuminates when the SET/COAST switch is turned ON while driving at 40 km/h (25 MPH) or higher.

*4: This light illuminates for about 2 seconds, and then goes out.

*5: Indicates the current gear position when sports shift is selected. It also illuminates for about 2 seconds when the ignition switch is turned ON.

Brought to you by Eris Studios
NOT FOR RESALE

E: SPEEDOMETER

1. GENERAL

- The speedometer system is an electrical type that uses electric signals from the ABS or vehicle dynamics control (VDC) control module.
- Since the system does not use mechanical components such as rotating cable, there are no opportunities of occurring such problems as meter needle vibration and cable disconnection. Also, it does not constitute any means of mechanical noise transmission.
- The odometer and trip meter readings appear on a liquid crystal display (LCD).
- At the trip meter display, the illumination level and the following trouble information (abnormality of various control modules, communication system, vehicle speed signals, etc.) are shown in addition to the trip meter reading.

Indication	Indicated fault
“Er --”	High speed and low speed CAN communication failed simultaneously
“Er HC”	High speed CAN communication failure
“Er LC”	Low speed CAN communication failure
“Er IU”	Body integrated unit failure inside
“Er EG”	Engine control module communication counter failure
“Er tC”	Transmission control module communication counter failure
“Er Ab”	ABS/VDC control module communication counter failure
“Er SP”	Vehicle speed signal abnormal (ABS/VDC diagnostic trouble code information)
“Er SS”	Vehicle speed signal abnormal (wheel speed signal abnormal)

2. OPERATION

The ABS or VDC control module calculates the vehicle speed based on signals from the four wheel speed sensors and sends vehicle speed signals (4 pulses per rotation of wheel) to the speedometer drive circuit and odometer/trip meter drive circuit in the speedometer.

NOTE:

Signals from the ABS or VDC control module are also used by the engine control module, automatic transmission control module, etc.

3. SPECIFICATIONS

Speedometer	Type		Electric pulse type
	Indication	km/h	The needle points to 60 km/h (37.3 MPH) when 2,548 pulses are input per minute.
		MPH	The needle points to 60 MPH (95 km/h) when 4,104 pulses are input per minute.
Odometer	Type		Pulse count type
	Display		LCD/6 digits; 0 to 999,999 km (miles)
	Indication		Counts up 1 km per 2,548 pulses. (4,104 pulses per mile)(Count down is impossible.)
Trip meter	Type		Pulse count type
	Display		LCD/4 digits; 0 to 999.9 km (miles) and 1000 to 9999 km (miles).
	Indication		Counts up 1 km per 2,548 pulses. (4,104 pulses per mile)(To change the trip meter from A to B or B to A, push the knob momentarily. To return the trip meter to zero indication, keep the knob pushed for more than 1 second.)

COMBINATION METER

INSTRUMENTATION/DRIVER INFO

F: TACHOMETER

The tachometer drive circuit is connected to the engine speed sensing circuit in the engine control module.

When the engine speed increases or decreases, the voltage of the circuit also increases or decreases, changing the magnetic force of the tachometer drive coil.

The tachometer needle then moves in accordance with change in the engine speed.

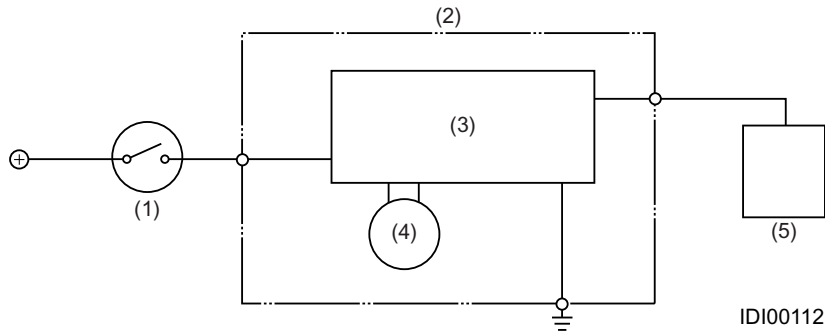

- (1) Ignition switch
- (2) Combination meter
- (3) Microprocessor

- (4) Tachometer
- (5) Engine control module

G: WATER TEMPERATURE GAUGE

- Water temperature signals are generated at the engine coolant temperature sensor on the engine, and after converted into digital signals, these signals are sent via the body integrated unit to the combination meter.
- The resistance of the engine coolant temperature sensor changes according to the engine coolant temperature. Therefore, the signals sent to the water temperature gauge also changes according to the engine coolant temperature. As the change in signals causes the magnetic force of the step motor to change, the gauge needle moves according to the engine coolant temperature.
- When the coolant is at a normal operating temperature of approx. 85 to 100°C (158 to 212°F), the gauge needle stays in the middle of the indication range as shown below.

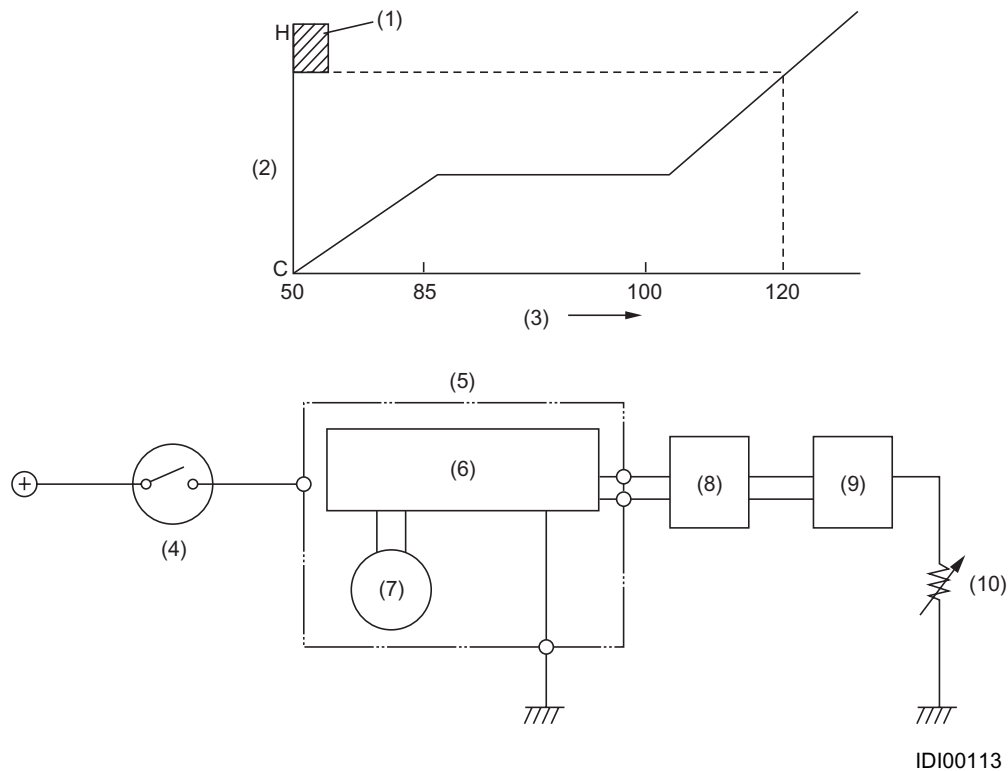

- (1) Red zone
- (2) Indication
- (3) Temperature (°C)
- (4) Ignition switch
- (5) Combination meter

- (6) Microprocessor
- (7) Water temperature gauge
- (8) Body integrated unit
- (9) Engine control module
- (10) Engine coolant temperature sensor

COMBINATION METER

INSTRUMENTATION/DRIVER INFO

H: FUEL GAUGE

1. GENERAL

● The fuel gauge unit consists of a float and a potentiometer whose resistance varies depending on movement of the float. It is located inside the fuel tank and forms an integral part of the fuel pump. The fuel gauge indicates the fuel level in the tank when the ignition switch is in the ON position. When the trip knob is pushed, the fuel gauge illumination comes ON and the fuel level registered just before the ignition switch was turned OFF is indicated, even when the ignition switch is in the OFF position.

● All models are equipped with two fuel level sensors. These sensors are installed in the fuel tank, one on the right side and the other on the left side. Two sensors are necessary because the fuel tank is divided into main and sub tank compartments.

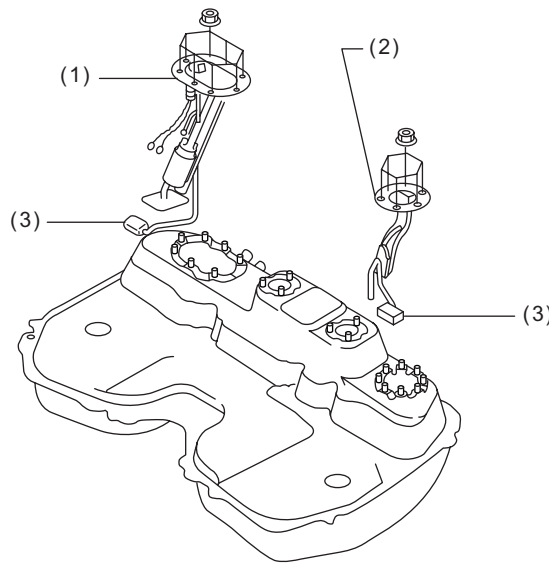

IDI00017

- (1) Main fuel level sensor
- (2) Fuel sub level sensor
- (3) Float

COMBINATION METER

INSTRUMENTATION/DRIVER INFO

2. OPERATION

The low fuel warning light operates as follows:

The signal from the fuel level sensor is converted into a digital signal at the body integrated unit, and then sent to the combination meter. The combination meter microprocessor continually monitors this signal. It turns on the low fuel warning light in the combination meter if a resistance value corresponding to the critical fuel level is detected for a certain time while driving.

This monitoring time has been decided to avoid false operation of the warning light, which may happen when a large part of remaining fuel is collected temporarily in the sub tank compartment.

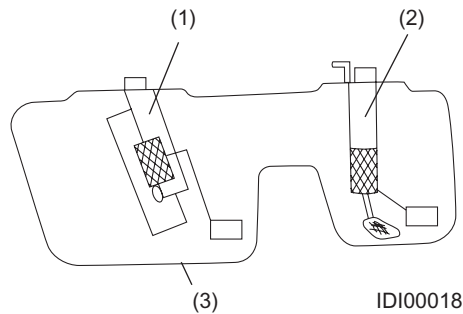

- (1) Main fuel level sensor
- (2) Fuel sub level sensor
- (3) Fuel tank

3. SPECIFICATIONS

	Fuel level	Resistance
Main fuel level sensor	Full	1.0 — 3.0Ω
	Empty	30.9 — 32.9Ω
Fuel sub level sensor	Full	1.0 — 3.0Ω
	Empty	61.1 — 63.1Ω

COMBINATION METER

INSTRUMENTATION/DRIVER INFO

I: DIAGNOSIS MODE

1. GENERAL

The combination meter is provided with a self diagnosis function and a diagnostic trouble code display function which indicate DTCs for the engine, transmission and ABS/VDC control modules. To enter diagnosis mode, the diagnosis connector located near the fuse box under the right side of the driver's seat is used.

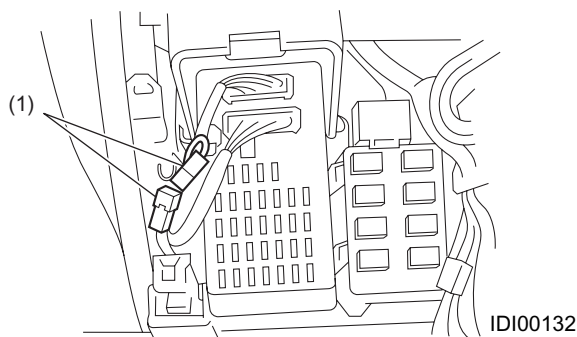

(1) Diagnosis connector

2. PROCEDURE

● Entering diagnosis mode

- 1) Connect the diagnosis connector.
- 2) Turn ON the ignition switch.
- 3) During initial operation of the meter and while the needle is moving, push the trip knob once to enter diagnostic trouble code display mode, or push the knob twice to enter self diagnosis mode.

NOTE:

If the vehicle is driven while in diagnosis mode (vehicle speed signals input), diagnosis mode is cancelled.

● To exit diagnosis mode

Turn OFF the ignition switch and disconnect the diagnosis connector to exit diagnosis mode.

Brought to you by Eris Studios
NOT FOR RESALE

3. FUNCTION

● **Self diagnosis mode**

When self diagnosis mode is activated, the system switches to warning lights, indicators, needle movement, illumination or buzzer check mode (sports shift) each time the trip knob is pushed.

● **Diagnostic trouble codes display mode**

When diagnostic trouble code display mode is activated, the display switches to indicate engine control module, transmission control module, or ABS/VDC control module diagnostic trouble codes each time the trip knob is pushed. In addition to the type of control module, the display will show whether the diagnostic trouble codes are now being received, present, or not. If CAN communication is failed, "-----" is displayed.

Control module	Status	Indication
Engine control module	Receiving diagnostic trouble codes	Trip "A" + "P (blink)"
	Diagnostic trouble codes present	Trip "A" + "P xxxx"
	No failure exists	Trip "A" + "P ----"
Transmission control module	Receiving diagnostic trouble codes	Trip "B" + "P (blink)"
	Diagnostic trouble codes present	Trip "B" + "P xxxx"
	No failure exists	Trip "B" + "P ----"
ABS/VDC control module	Receiving diagnostic trouble codes	Trip "A" + "C (blink)"
	Diagnostic trouble codes present	Trip "A" + "C xxxx"
	No failure exists	Trip "A" + "C ----"
CAN communication error	—	"-----"

CLOCK UNIT

Brought to you by Eris Studios
NOT FOR RESALE

2. Clock Unit

A: GENERAL

The clock unit display can be switched to indicate outside air temperature, fuel efficiency, remaining travel distance or continuous driving time, by operating a button. The DISP button is used for switching the display, and the indicated information switches in the following sequence each time the button is pressed: outside temperature → fuel efficiency at the instant → average fuel efficiency → remaining travel distance → continuous driving time. These data are sent from the combination meter by means of digital communication. This clock unit is provided with a function to automatically display a failure; if the accessory power circuit is open it displays “Acc”, and if the ignition power circuit is open it displays “ign”. If an abnormality is detected in the communication between the combination meter and clock unit or in the received data, “Err” is displayed. If no data can be received, “Err” will always be displayed even when the indication is switched with the DISP button, but when only a specific data is not received, “Err” will be displayed only when the indication is switched to display that data. For example, if outside temperature data is not received “Err” will be displayed only when the thermometer feature is selected, and other indications such as the fuel efficiency meter will be displayed normally.

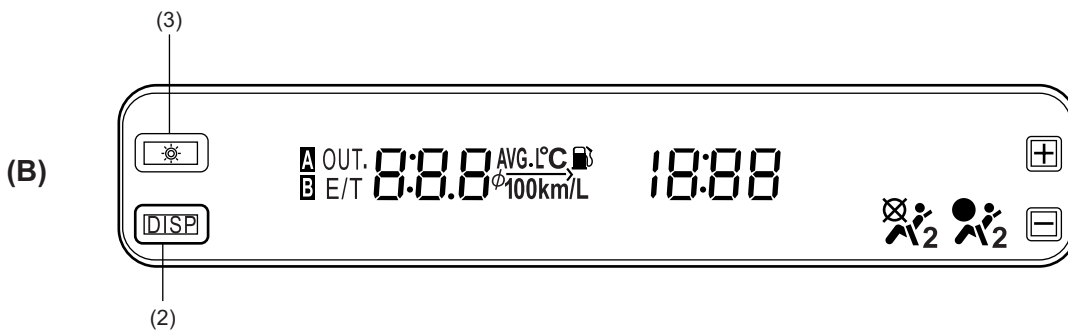
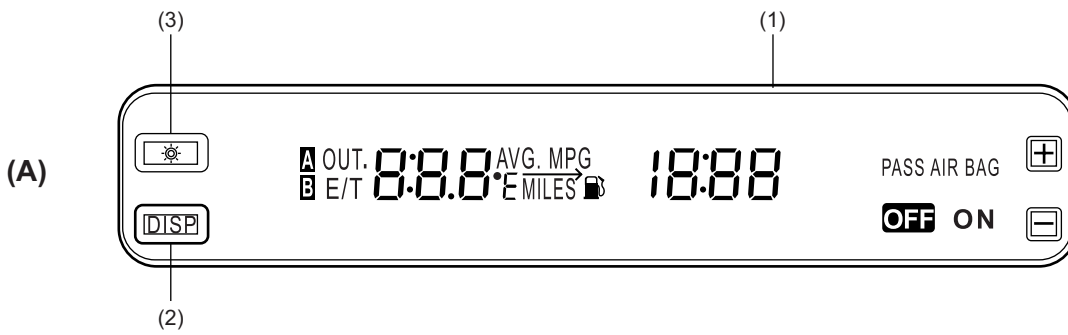

(A) For U.S.

(B) For Canada

(1) Clock unit

(3) BRIGHT button

(2) DISP button

B: OPERATION**1. CLOCK DISPLAY**

The clock shows time when the ignition switch is turned to ACC or further from OFF.

2. INSTANT FUEL EFFICIENCY, AVERAGE FUEL EFFICIENCY, REMAINING TRAVEL DISTANCE AND CONTINUOUS DRIVING TIME DISPLAY

The combination meter microprocessor performs calculations based on vehicle speed signals from the ABS/VDC control module, remaining fuel signals from the body integrated unit, fuel efficiency signals from the engine control module, and engine start signals, and then sends the data to the clock unit.

- Average fuel efficiency

The value is calculated from the distance and total amount of consumed fuel since the trip meter has been reset the last time.

- Instant fuel efficiency

The value is calculated during driving, based on the traveled distance and amount of consumed fuel recorded for a certain period.

- Remaining travel distance

The value is calculated from the average fuel efficiency in recent 30 km (18.8 miles) and the amount of remaining fuel.

- Continuous driving time

Indicates the total time since the engine has been started.

3. OUTSIDE AIR TEMPERATURE DISPLAY

The body integrated unit performs calculations based on outside air temperature signals from the ambient sensor and vehicle speed signals from the ABS/VDC control module, and then sends the data via the combination meter to the clock unit.

4. BRIGHT (DIMMER CANCELING) FUNCTION

The dimmer can be cancelled by pushing the BRIGHT button when the lighting switch is ON. The lights returns to the dimmed state when the button is pushed again.

5. PASSENGER'S SEAT AIRBAG INDICATOR

When this indicator (a mark on vehicles for Canada) is ON, the passenger's seat airbag will deploy in case of a front collision that should cause the airbag system to activate. When the indicator (a mark on vehicles for Canada) is OFF the passengers seat airbag will not deploy.

CLOCK UNIT

INSTRUMENTATION/DRIVER INFO

C: SCHEMATIC DRAWINGS

Brought to you by Eris Studios
NOT FOR RESALE

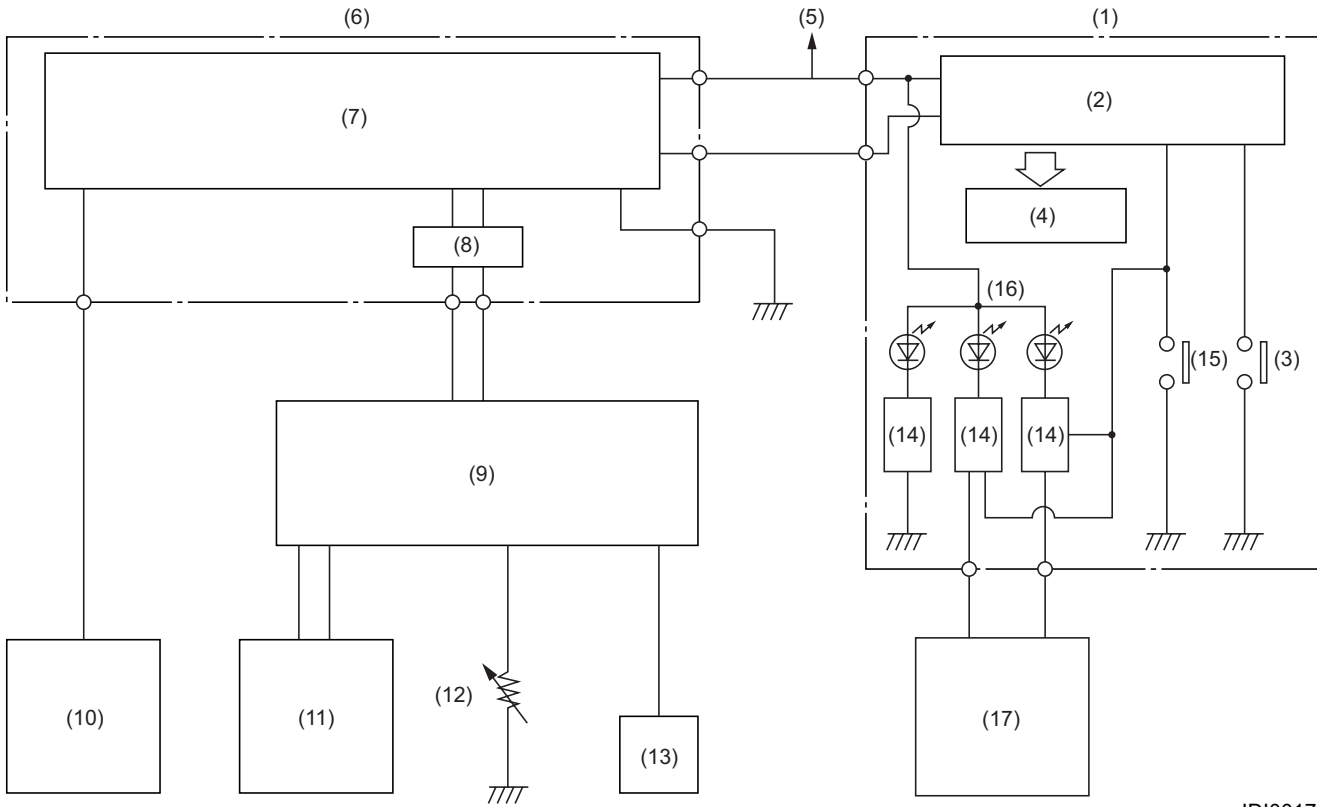

IDI00173

- | | |
|----------------------------------|--|
| (1) Clock unit | (10) ABS or VDC control module |
| (2) Microprocessor | (11) Engine control module |
| (3) DISP button | (12) Fuel level sensor |
| (4) Display | (13) Ambient sensor |
| (5) Ignition switch | (14) Dimmer canceling circuit |
| (6) Combination meter | (15) BRIGHT button |
| (7) Microprocessor | (16) Passenger's seat airbag indicator |
| (8) CAN transmitter and receiver | (17) Airbag control module |
| (9) Body integrated unit | |