

Brought to you by Eris Studios  
NOT FOR RESALE

# **POWER ASSISTED SYSTEM (POWER STEERING)**

# TILT STEERING COLUMN

POWER ASSISTED SYSTEM (POWER STEERING)

## 1. Tilt Steering Column

### A: TILT MECHANISM

- The steering wheel vertical position can be adjusted within a 38 mm (1.50 in) range by using the tilt lever to unlock the steering column and lock it again at the desired position.

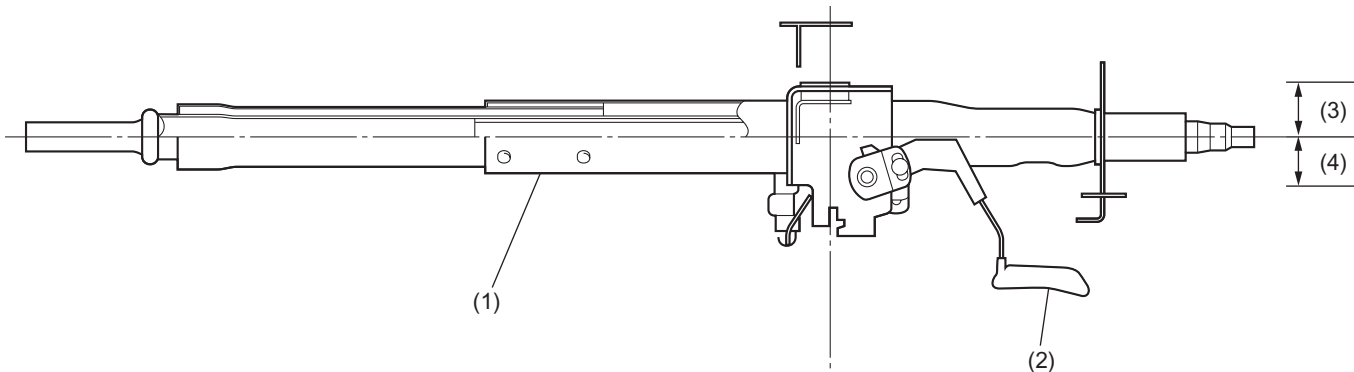

PS-00470

- (1) Tilt steering column
- (2) Tilt lever
- (3) 23 mm (0.91 in)
- (4) 15 mm (0.59 in)

### B: ENERGY-ABSORBING MECHANISM

- To absorb the backward movement energy generated in the engine compartment in the event of a frontal collision, a press-fitted pipes type steering column jacket has been adopted. When an impact load exceeding a certain level is applied to the steering column, jacket A slides on jacket B.

Since jacket B is press-fitted in jacket A, friction generated between them absorbs the impact. The column bending load is supported by the press-fitted jackets.

- Another measure to alleviate impact on the driver in the event of a collision is the ripping plate, which is located between the steering column and the tilt bracket attached to the steering support beam. When a large impact load is applied to the steering column, the ripping plate is deformed and torn progressively. The impact energy is absorbed during this process.

# TILT STEERING COLUMN

POWER ASSISTED SYSTEM (POWER STEERING)

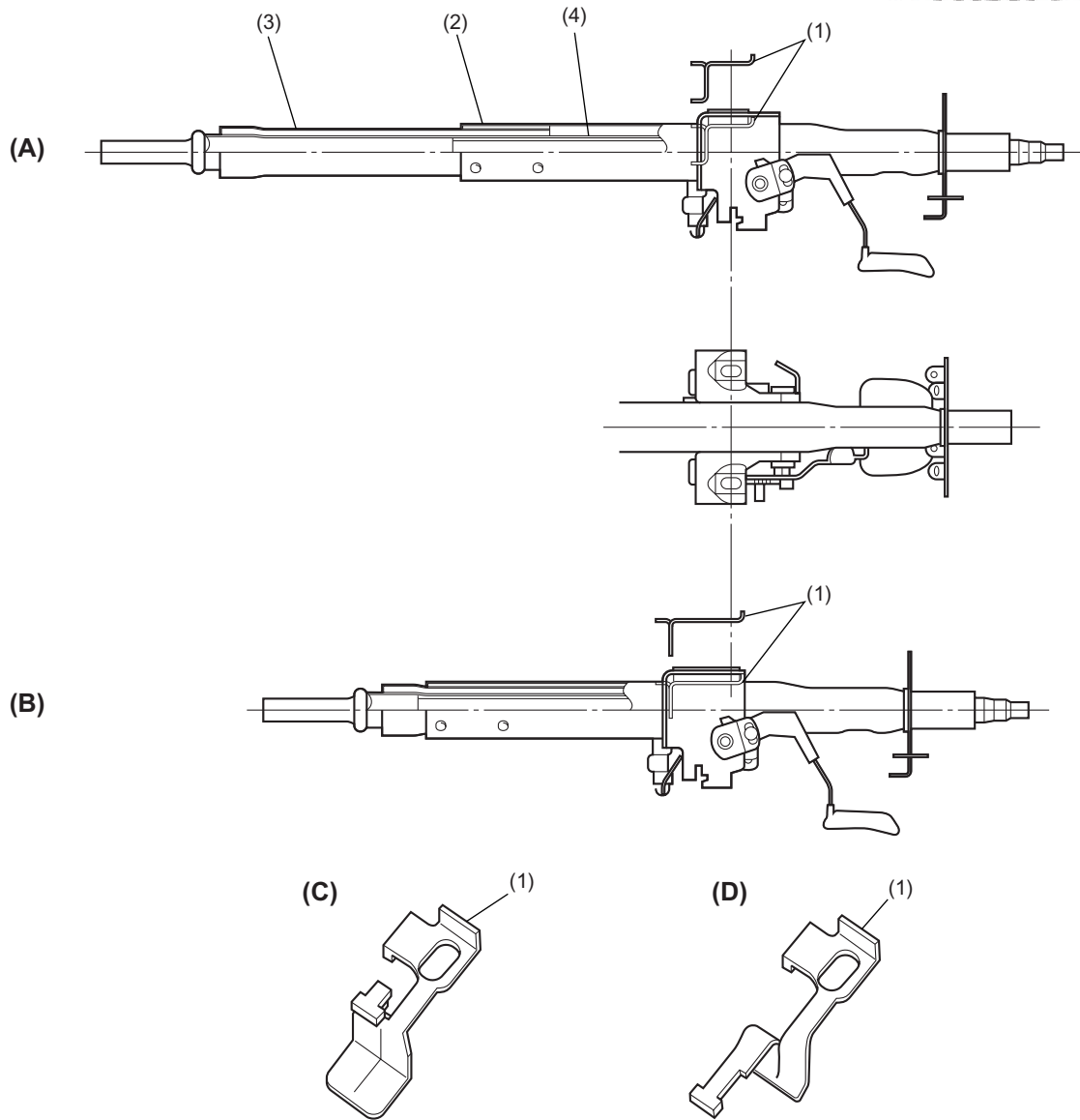

- (A) Before absorption of impact energy
- (B) After absorption of impact energy
- (C) Before ripping
- (D) After ripping

- (1) Ripping plate
- (2) Jacket A
- (3) Jacket B
- (4) Shaft

PS-00471

## TILT STEERING COLUMN

POWER ASSISTED SYSTEM (POWER STEERING)

---

### C: STEERING SUPPORT BEAM

- The steering column is held in position by a support beam, which is installed crosswise in the vehicle body at a level close to the steering wheel to reduce the overhang distance of the steering wheel from the supporting point of the column. The steering shaft upper bearing is also located close to the steering wheel to increase supporting efficiency as well as to minimize vibration of the steering wheel.

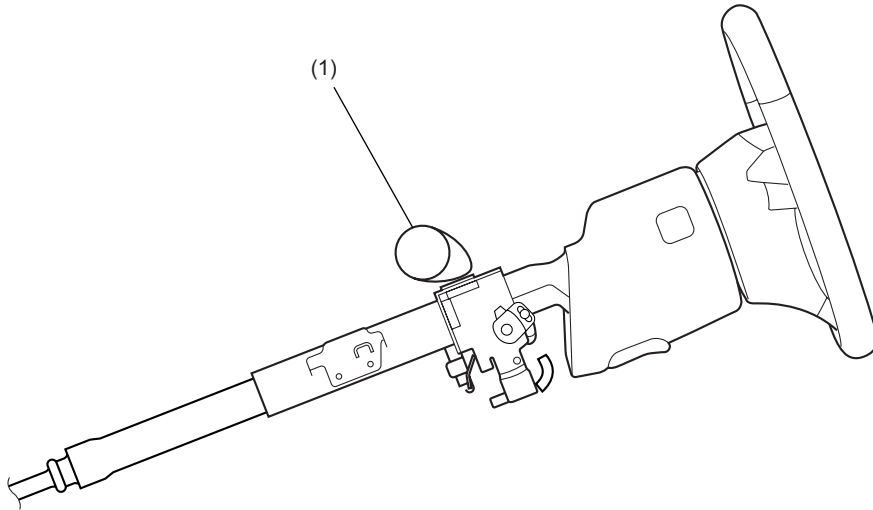

PS-00475

(1) Steering support beam

## 2. Power Steering System

### A: HYDRAULIC SYSTEM

- The fluid pump is directly driven by the engine through a belt.
- The fluid flow is maintained almost constant regardless of change in the engine speed by the function of the flow control valve. The flow-regulated fluid is delivered to the control valve through hose A.
- When the steering wheel is turned, the rotary control valve connected to the pinion shaft opens the hydraulic circuit corresponding to the direction in which the steering wheel is turned. The fluid then flows into chamber A or B via pipe A or B.
- The fluid pressure in chamber A or B acts on the rack piston in the same direction as the rack shaft is moved by rotation of the steering wheel. This helps reduce the effort required of the driver to operate the steering wheel.
- Movement of the rack piston causes the fluid in the other chamber to return to the reservoir tank via pipe A or B, control valve, and hose B.
  - As the steering shaft is connected to the pinion shaft mechanically via the rotary control valve, the steering system can operate as a manual system even if the hydraulic system becomes inoperative.
  - To control the maximum fluid pressure, a relief valve is built into the fluid pump to prevent build-up of excessive fluid pressure.
- Since a damper valve is provided in the fluid passage, the steering stability in straight forward direction is improved and kickback is reduced.

# POWER STEERING SYSTEM

POWER ASSISTED SYSTEM (POWER STEERING)

Brought to you by Eris Studios  
NOT FOR RE-USE

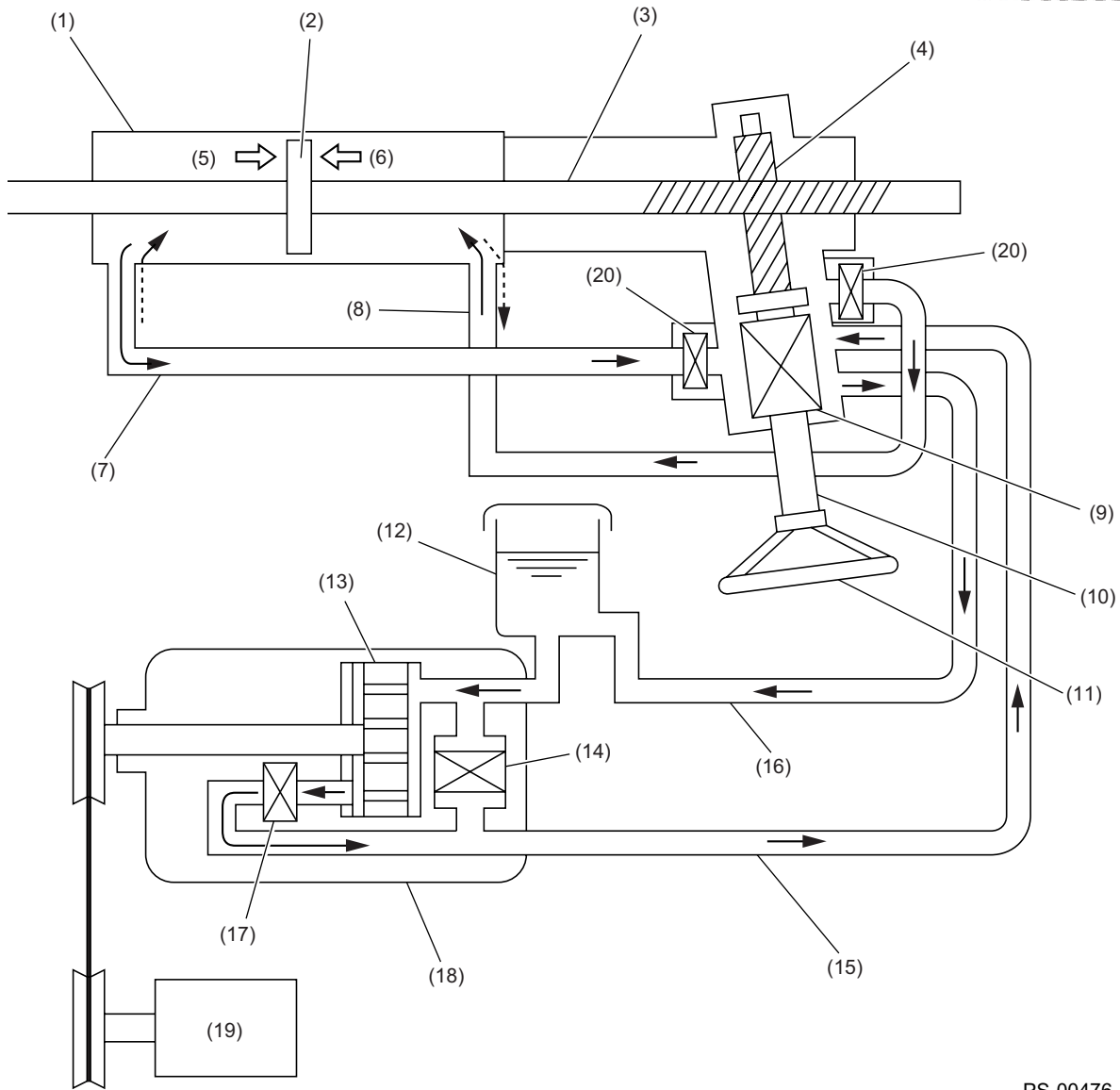

PS-00476

- |                     |                     |
|---------------------|---------------------|
| (1) Power cylinder  | (11) Steering wheel |
| (2) Rack piston     | (12) Tank           |
| (3) Rack shaft      | (13) Vane pump      |
| (4) Pinion shaft    | (14) Relief valve   |
| (5) Chamber A       | (15) Hose A         |
| (6) Chamber B       | (16) Hose B         |
| (7) Pipe A          | (17) Control valve  |
| (8) Pipe B          | (18) Fluid pump     |
| (9) Control valve   | (19) Engine         |
| (10) Steering shaft | (20) Damper valve   |

# POWER STEERING SYSTEM

POWER ASSISTED SYSTEM (POWER STEERING)

## B: GEARBOX ASSEMBLY

### 1. POWER CYLINDER

The gearbox integrates the control valve and power cylinder into a single unit. The rack shaft serves as a power cylinder piston. The rotary control valve is located around the pinion shaft.

The rotary control valve and power cylinder are connected to each other by two hydraulic fluid pipes.

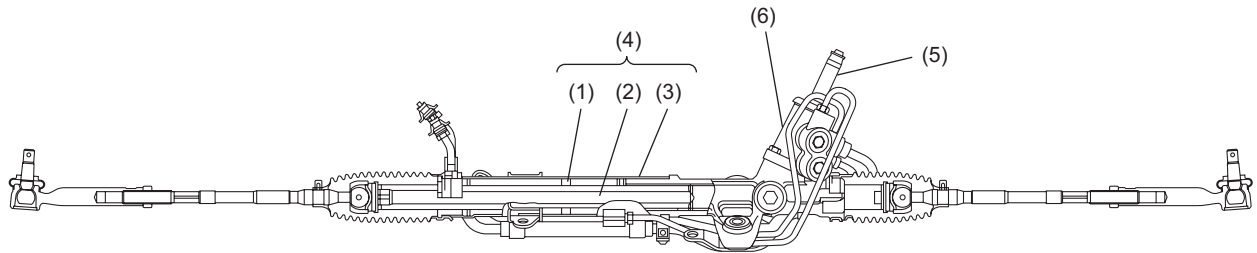

PS-00626

- (1) Piston
- (2) Rack shaft
- (3) Cylinder

- (4) Power cylinder
- (5) Pinion shaft
- (6) Control valve

# POWER STEERING SYSTEM

## POWER ASSISTED SYSTEM (POWER STEERING)

### 2. ROTARY CONTROL VALVE

The rotary control valve consists of a rotor (which rotates together with the steering shaft), a pinion (which is connected to the rotor and torsion bar), and a sleeve (which rotates together with the pinion). The rotor and sleeve have grooves C and D, respectively, which form fluid passages  $V_1$  through  $V_4$ .

The pinion is in mesh with the rotor with adequate clearance, which enable the rack to be moved manually by rotating the steering shaft (fail-safe feature).

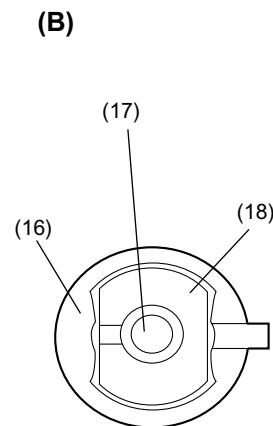
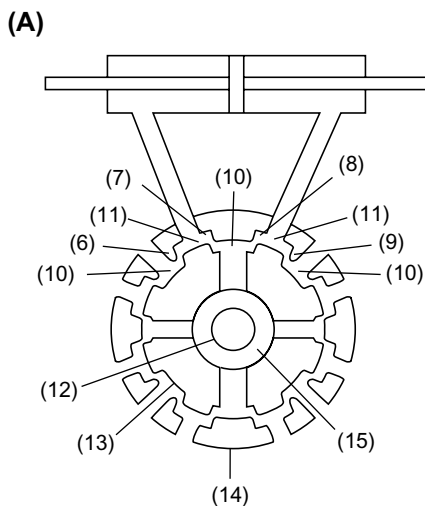
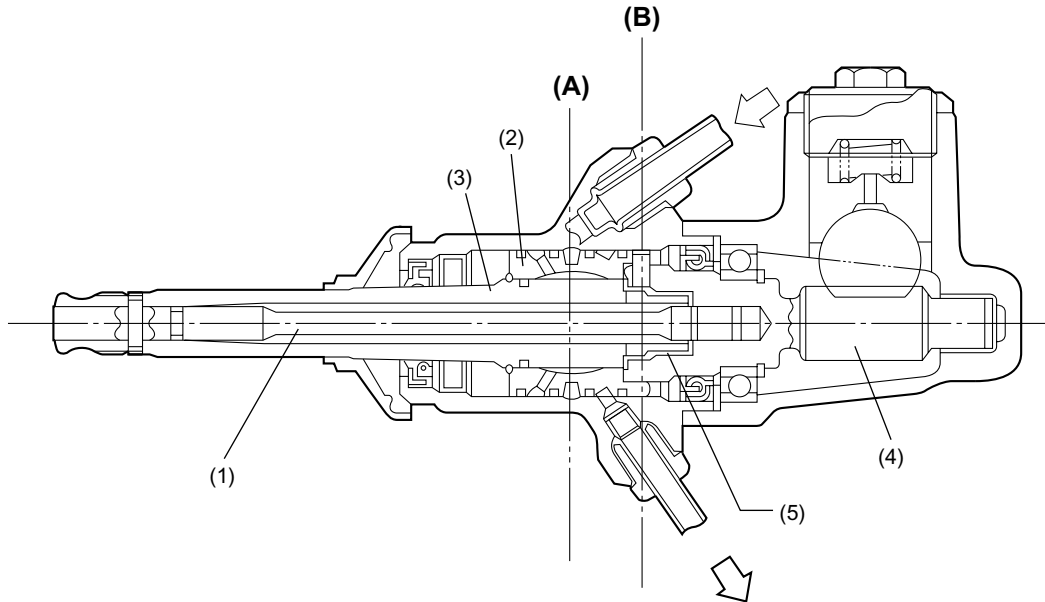

PS-00011



# POWER STEERING SYSTEM

POWER ASSISTED SYSTEM (POWER STEERING)

---

- (1) Torsion bar
  - (2) Sleeve
  - (3) Rotor
  - (4) Pinion
  - (5) Pinion-to-rotor engagement (fail-safe feature)
  - (6) Fluid passage  $V_1$
  - (7) Fluid passage  $V_2$
  - (8) Fluid passage  $V_3$
  - (9) Fluid passage  $V_4$
  
  - (10) Groove C
  - (11) Groove D
- (12) Torsion bar
  - (13) Rotor
  - (14) Sleeve
  - (15) Fluid return line (to reservoir tank)
  - (16) Pinion
  - (17) Torsion bar
  - (18) Rotor
- (A)** Cross-sectional view A (fluid passage switching circuit)
- (B)** Cross-sectional view B (pinion-to-rotor engagement)

# POWER STEERING SYSTEM

## POWER ASSISTED SYSTEM (POWER STEERING)

- Principle of operation

When the torsion bar is twisted by a rotational force applied to the steering wheel, the relative position between the rotor and sleeve changes. This changes the cross-sectional area of fluid passages  $V_1$ ,  $V_2$ ,  $V_3$  and  $V_4$ . The fluid passages are thus switched and the fluid pressure is controlled in accordance with the operation of the steering wheel.

- When no steering force is applied:

The rotor and sleeve are held at the neutral position. Fluid passages  $V_1$ ,  $V_2$ ,  $V_3$  and  $V_4$ , which are formed by grooves C and D are open equally. Under this condition, the fluid from the pump returns to the reservoir tank so that neither fluid pressure builds up nor the rack piston moves in the power cylinder.

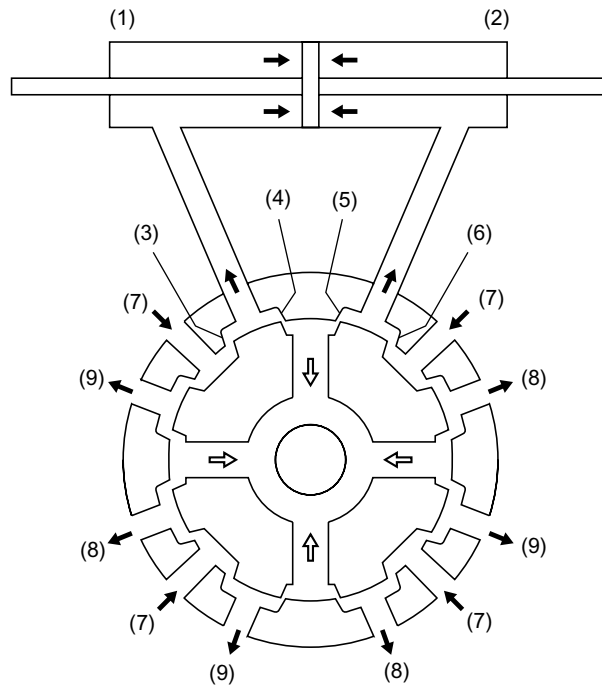

PS-00012

- (1) Chamber A
- (2) Chamber B
- (3)  $V_1$

- (4)  $V_2$
- (5)  $V_3$
- (6)  $V_4$

- (7) From fluid pump
- (8) To A
- (9) To B

# POWER STEERING SYSTEM

POWER ASSISTED SYSTEM (POWER STEERING)

- When steering force is applied:

When the steering wheel is turned to the right, for example, fluid passages  $V_1$  and  $V_3$  are opened while fluid passages  $V_2$  and  $V_4$  are nearly closed.

At this point, the fluid pressure in chamber A of the power cylinder increases depending on the degree of closure of fluid passages  $V_2$  and  $V_4$  so that the rack piston moves to the right. The fluid in chamber B, on the other hand, is drained through fluid passage  $V_3$  into the reservoir tank.

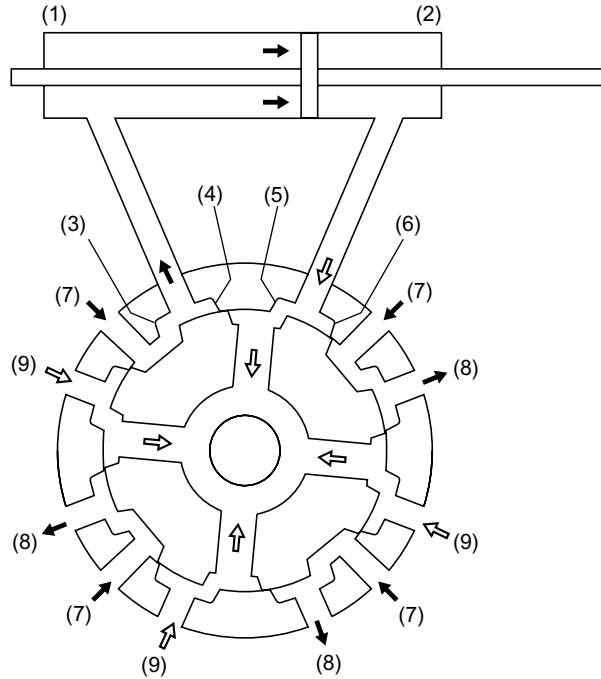

PS-00013

(1) Chamber A

(2) Chamber B

(3)  $V_1$

(4)  $V_2$

(5)  $V_3$

(6)  $V_4$

(7) From fluid pump

(8) To A

(9) From B

- Fail-safe function

If fluid pressure fails to build up due to, for example, a broken fluid pump drive belt, the steering wheel rotating torque is transmitted from the valve rotor to the pinion through mechanical engagement between them.

# POWER STEERING SYSTEM

POWER ASSISTED SYSTEM (POWER STEERING)

## 3. DAMPER VALVE

The damper valve is incorporated in the control valve body and is placed in the fluid passage at between the rotary control valve and the power cylinder chamber. Since the damper valve limits rapid flow of fluid caused by external force, the steering stability in straight forward direction is improved and kickback is reduced.

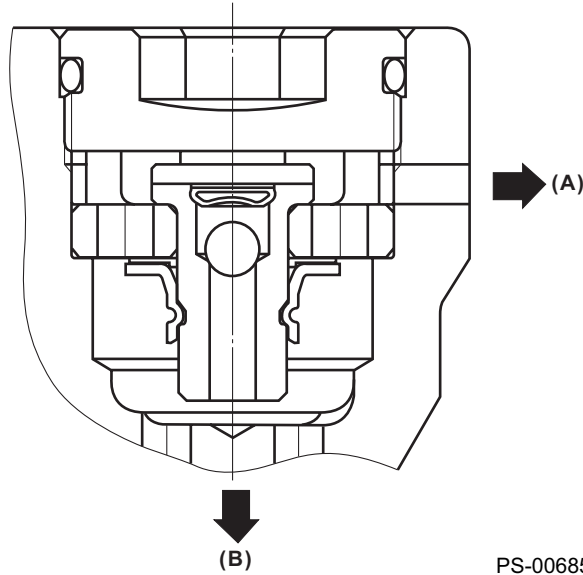

PS-00685

- (A) To control valve
- (B) To chamber A or B

# POWER STEERING SYSTEM

POWER ASSISTED SYSTEM (POWER STEERING)

## C: FLUID PUMP AND RESERVOIR TANK

The fluid pump is a vane type driven by the engine via belt.

The reservoir tank is mounted on the vehicle body.

The fluid pump incorporates the flow control valve and relief valve, each performing the following functions:

- The flow control valve regulates the flow rate of discharged fluid to a constant level irrespective of the engine speed.
- The relief valve protects the system from excessively high pressures that may occur, for example, when the steering wheel is turned all the way.
- To stabilize the fluid temperature, an oil cooler is installed between the reservoir tank and gear-box.

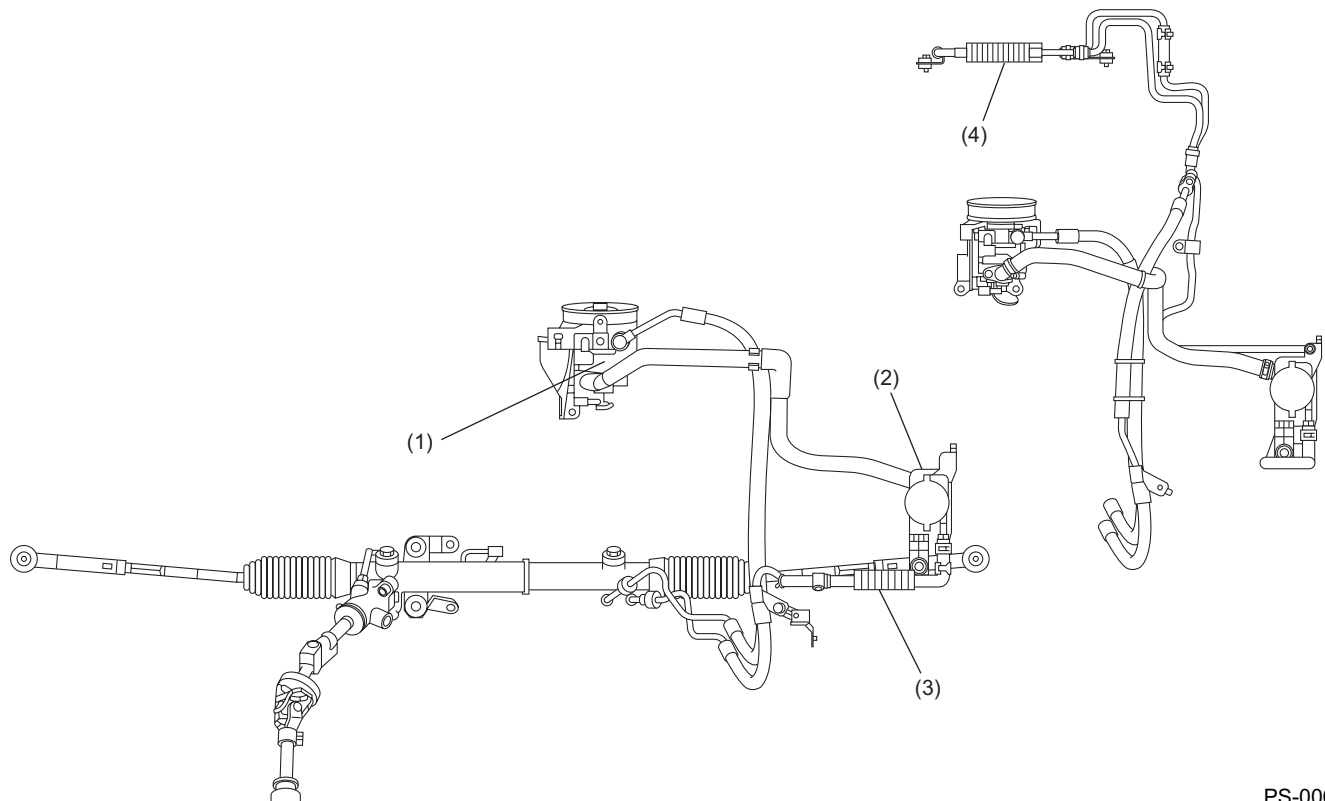

PS-00627

- (1) Fluid pump
- (2) Reservoir tank
- (3) Oil cooler (H4 models)
- (4) Oil cooler (H6 models)

# POWER STEERING SYSTEM

POWER ASSISTED SYSTEM (POWER STEERING)

Brought to you by Eris Studios  
NOT FOR RESALE

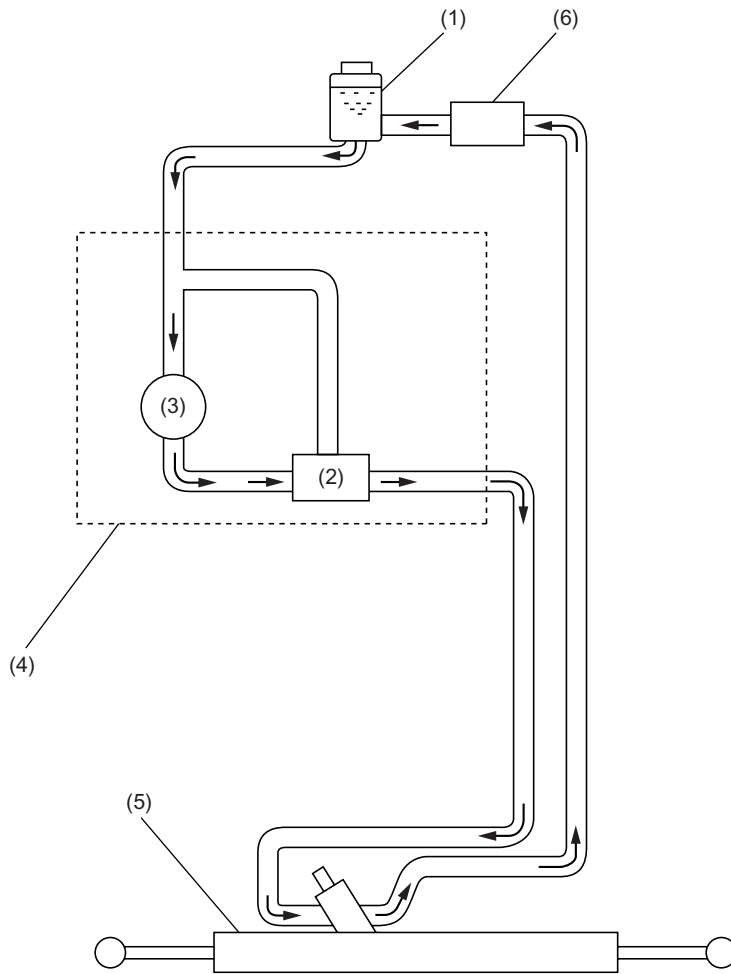

PS-00504

- (1) Reservoir tank
- (2) Relief valve assembly
- (3) Vane pump

- (4) Fluid pump assembly
- (5) Steering gearbox
- (6) Oil cooler

# POWER STEERING SYSTEM

## POWER ASSISTED SYSTEM (POWER STEERING)

● The fluid pump is belt-driven by the engine. The fluid flow is controlled according to the engine speed so that an adequate steering resistance is given during high-speed operation. The fluid pump is a variable capacity type vane pump whose delivery rate per rotation decreases as the engine speed increases. The pump is integral with a pump control valve and relief valve.

● The vane pump consists of a rotor, a cam ring, and 11 vanes.

When the rotor rotates, the vane in each slot of the rotor is moved out by centrifugal force in radial directions and pressed against the cam ring. The fluid from the suction port is confined in chambers formed between two adjacent vanes and carried to the discharge port. Since the cam ring is movable in relation to the rotor, the volume of each chamber is variable. This enables the delivery rate per rotation of the pump to be changed.

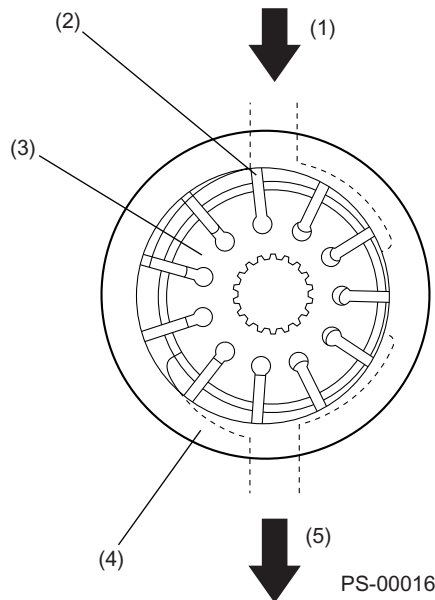

- (1) Suction
- (2) Vane
- (3) Rotor
- (4) Cam ring
- (5) Discharge

# POWER STEERING SYSTEM

## POWER ASSISTED SYSTEM (POWER STEERING)

### ● Flow control

The variable capacity pump changes its delivery rate per rotation by changing the degree of eccentricity of the cam ring according to its rotating speed (engine speed).

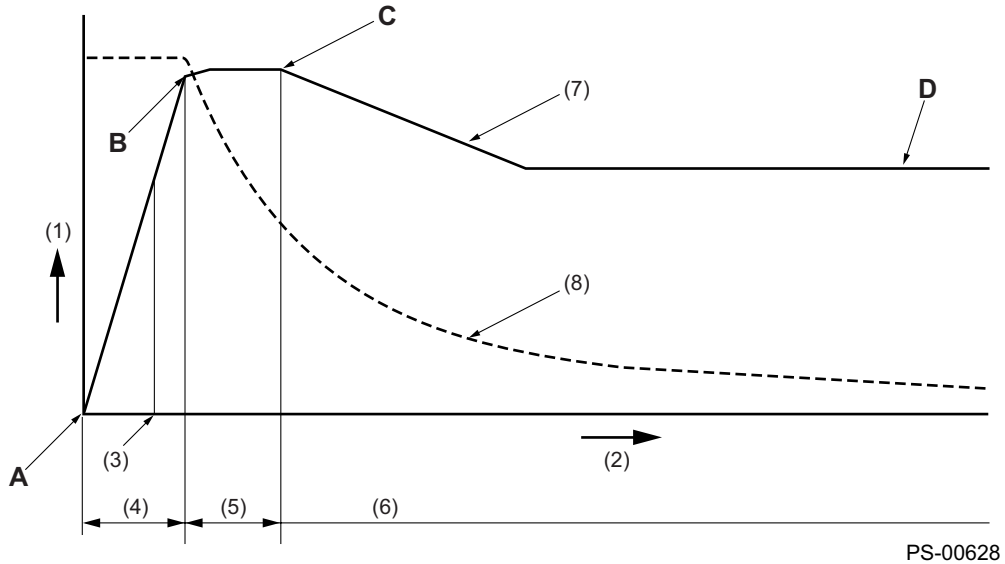

PS-00628

- |                |                                        |
|----------------|----------------------------------------|
| (1) Fluid flow | (5) Mid-speed                          |
| (2) Pump speed | (6) High-speed                         |
| (3) Idling     | (7) Delivery rate per unit time        |
| (4) Low-speed  | (8) Delivery rate per rotation of pump |

### NOTE:

In the following description, pump speed ranges will be indicated using the speed points A through D shown in the drawing above.



# POWER STEERING SYSTEM

POWER ASSISTED SYSTEM (POWER STEERING)

## Low-range-speed operation (A — B range)

In this speed range, as well as in all the other speed ranges, two different pump discharge pressures are always applied to the control valve; one is directly led from the discharge port to the left end of the valve and the other is led through an orifice (variable orifice) to the right end of the valve. Since the orifice has a pressure reducing effect, the latter pressure is lower than the former.

When the pump is operating at a low speed, its discharge pressure is also low, resulting in only small difference between the two pressures. In this condition, the valve stays pushed leftward by the spring, allowing the non-pressurized tank fluid to enter chamber A. To chamber B, on the other hand, the orifice-reduced discharge pressure is applied, so the cam ring is pushed leftward by the cam ring spring. This makes the eccentricity of the cam ring a maximum and, therefore, the delivery rate per rotation of the pump becomes a maximum.

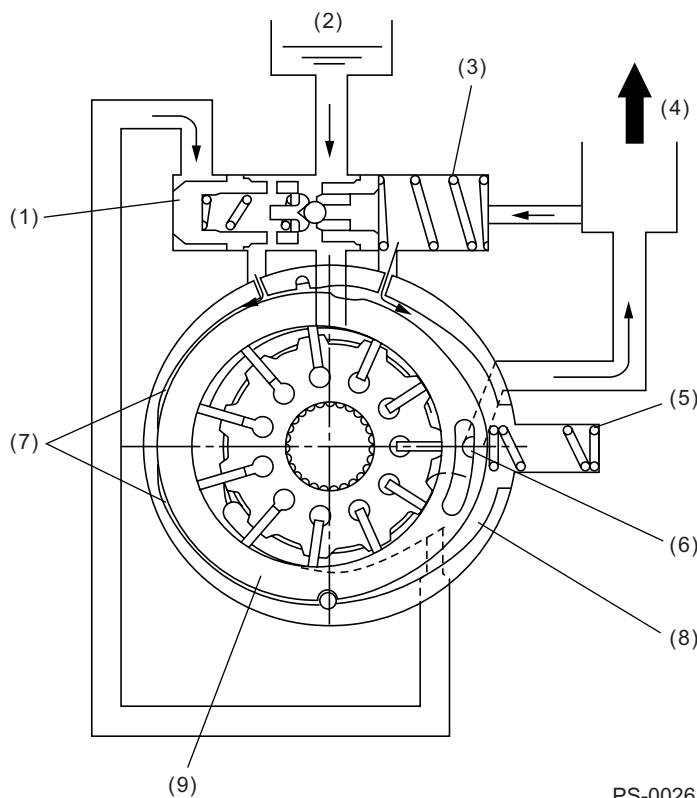

PS-00261

- |                          |                        |
|--------------------------|------------------------|
| (1) Control valve        | (6) Variable orifice   |
| (2) Reservoir tank fluid | (7) Pressure chamber A |
| (3) Control valve spring | (8) Pressure chamber B |
| (4) Gear box             | (9) Cam ring           |
| (5) Cam ring spring      |                        |

# POWER STEERING SYSTEM

## POWER ASSISTED SYSTEM (POWER STEERING)

### Mid- to high-range-speed operation (B — D range)

During mid-range speed operation, the pump increases its delivery rate. Since the pressure before passing through the variable orifice increases, the control valve moves rightward, overcoming the tension of the control valve spring. This movement of the control valve allows the pressure upstream of the variable orifice to be directed to chamber A after being adjusted to a necessary pressure\* by the port opening area created by the control valve. On the other hand, chamber B receives the reservoir pressure (suction pressure). This means that the pressure in chamber A is higher than that in chamber B. As a result, the cam ring moves rightward against the tension of the cam spring. This causes the delivery rate per rotation of the pump to be reduced, so that the flow rate of the fluid to the steering gear box decreases accordingly.

The above control is performed when the pump is operating at a speed in the B — D range.

\* The “necessary pressure” for chamber A is a pressure required to move the cam ring to the position corresponding to each predetermined flow rate (pump delivery rate). The pressure is obtained by changing the port opening area appropriately through displacement of the control valve. The displacement of the control valve is determined by how much the pressure before the variable orifice is different from that after the orifice.

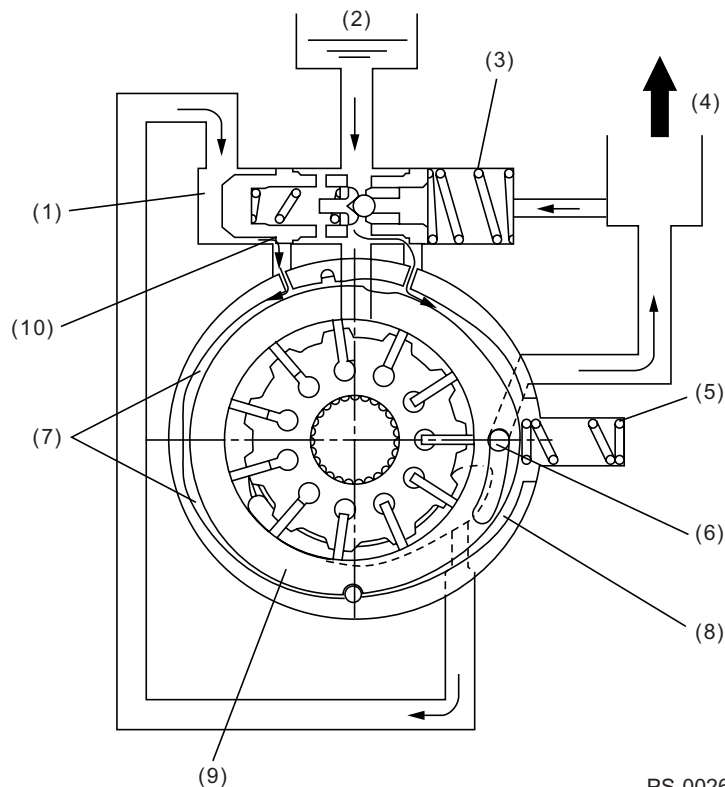

- |                          |                        |
|--------------------------|------------------------|
| (1) Control valve        | (6) Variable orifice   |
| (2) Reservoir tank fluid | (7) Pressure chamber A |
| (3) Control valve spring | (8) Pressure chamber B |
| (4) Gear box             | (9) Cam ring           |
| (5) Cam ring spring      | (10) Opening area      |

# POWER STEERING SYSTEM

POWER ASSISTED SYSTEM (POWER STEERING)

## Maximum pressure control

When the overall delivery rate of the pump exceeds a preset value, the relief valve opens to allow part of the discharged fluid to flow toward the suction side of the pump, thereby controlling the maximum pressure.

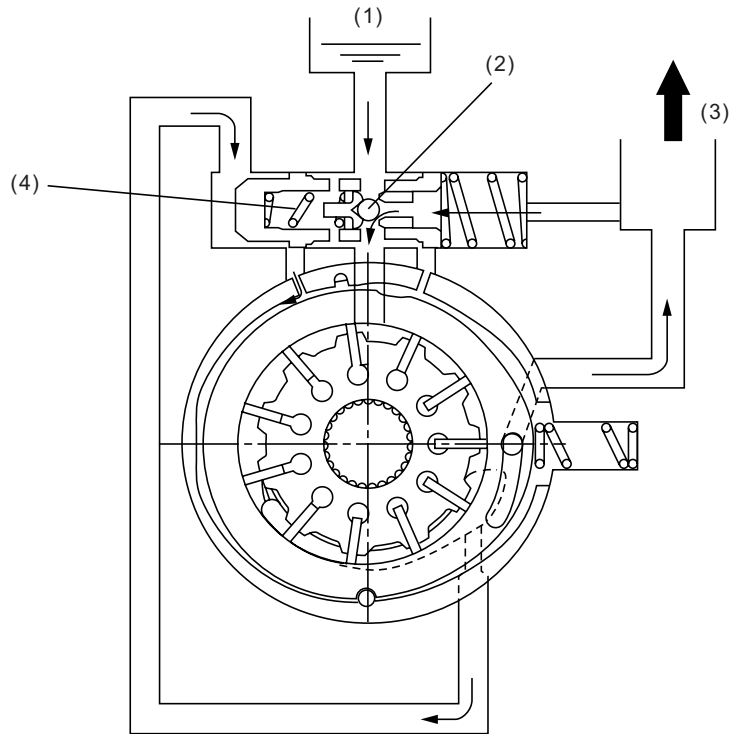

PS-00263

- (1) Reservoir tank fluid
- (2) Relief valve
- (3) Gear box
- (4) Relief spring