

Brought to you by Eris Studios  
NOT FOR RESALE

# **STARTING/CHARGING SYSTEMS**

# STARTER

STARTING/CHARGING

Brought to you by Eris Studios  
NOT FOR RESALE

## 1. Starter

The starter is of a reduction type.

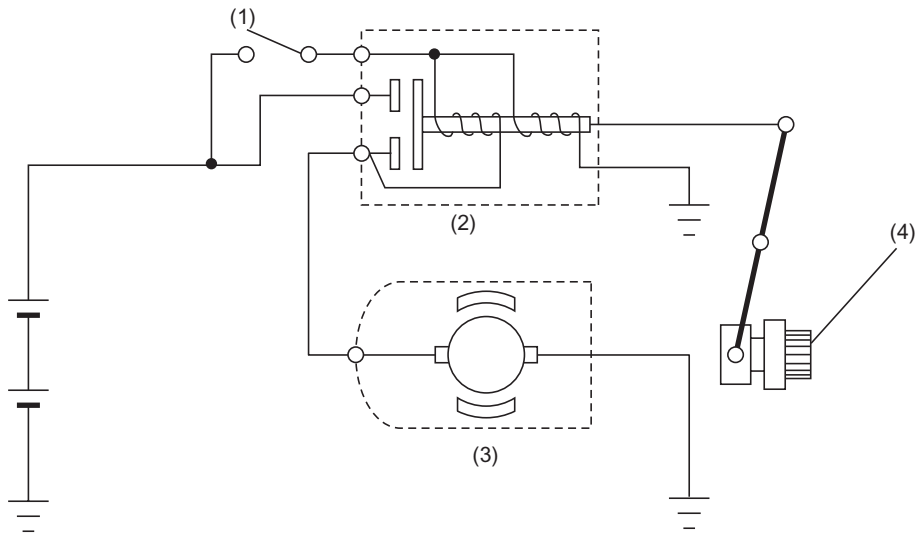

SC-02008

- (1) Starter switch
- (2) Magnet switch
- (3) Starter
- (4) Pinion

## 2. Generator

The generator has a built-in regulator which provides diagnostic functions in addition to a voltage regulating function as follows:

1) Voltage regulation

The on-off operation of transistor connects and disconnects the field current circuit, providing a constant level of output voltage.

2) Diagnosis warning

When any of the following problems occur, the charge light illuminates.

(1) No voltage generation

Brush wear exceeds specified wear limits, field coil circuit is broken, etc.

(2) Excessive output

Output voltage is greater than 16 volts (approx.)

(3) Terminal B disconnection

Harness is disconnected from generator terminal B.

(4) Terminal S disconnection

Harness is disconnected from generator terminal S. In this case, voltage is slightly greater than specified regulated voltage; however, voltage regulation is still controlled and the battery is prevented from becoming overcharged.

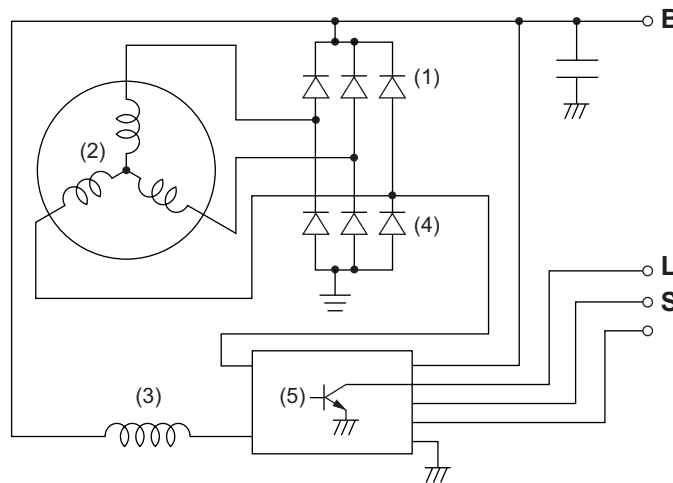

SC-02093

(1) Positive side diodes (3 pcs.)

(4) Negative side diodes (3 pcs.)

(2) Stator coil

(5) IC regulator

(3) Field coil

## BATTERY

STARTING/CHARGING

---

### 3. Battery

The battery is located in the left front part of the engine compartment. It is held on a tray by the battery holder.

Brought to you by Eris Studios  
NOT FOR RESALE