

Brought to you by Eris Studios
NOT FOR RESALE

SEATS

1. Front Seat

A: ADJUSTMENT

Adjustment ranges are expanded to fit a wider variety of body types.

- The height of each headrest is adjustable to any of the 3 positions available.
- The uppermost position of the backrest is 11° rearwards from the perpendicular; the reclining angle is widened.
- A “towel bar” type seat slide lever is used for easier operation.
- The seat lifter mechanism has been changed from a system that lifts only the cushion to a system that lifts the entire seat.

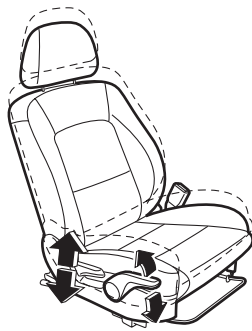

SE-00419



SE-00420

B: HEIGHT ADJUSTER

The driver's seat is provided with a height adjuster. Both the seat cushion and backrest rise every time the lifter lever is pulled up; they lower every time the lever is pushed down.

The lever is enlarged for easier operation.

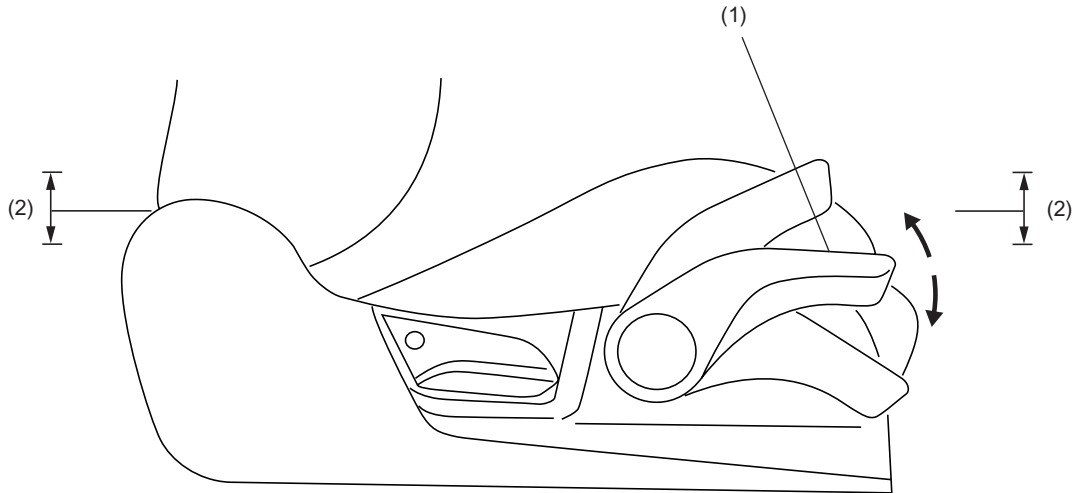

SE-00374

(1) Lifter lever

(2) Seat height adjustment range

C: ACTIVE HEADREST

In case of rear-end collision, the headrest moves forward to immediately support the passenger's head to reduce the possibility of injury to the neck.

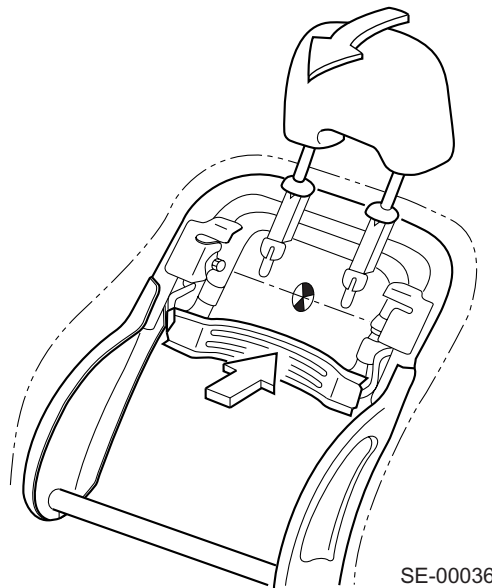

SE-00036

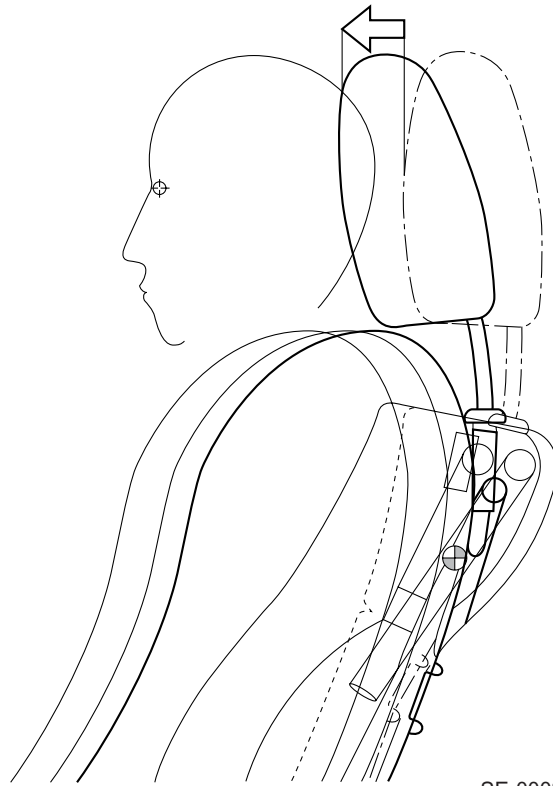

SE-00037

- 1) In case of rear-end collision, the passenger's body will move rearward by the impact.
- 2) When the body moves rearward, the thrust receiving plate inside the seat is pressed in.
- 3) When the thrust receiving plate is pressed in, the headrest moves forward due to a levering action.

2. Powered Seat System With Memory Preset (From '06MY)

A: GENERAL

- It is possible to register optimal seat positions adjusted by a driver (seat forward/back position, seat cushion height and angle, back rest angle) to the memory unit.
- Up to 2 seat positions can be registered, and even if the seat position has been changed, it will be possible to call out a registered seat position with a single button. It is possible to set this to use for different drivers, or to set a driving position and a rest position.
- The memory switch assembly for registering and calling out the memory, is located on the side cover of the driver's seat cushion (door side).

B: COMPONENT

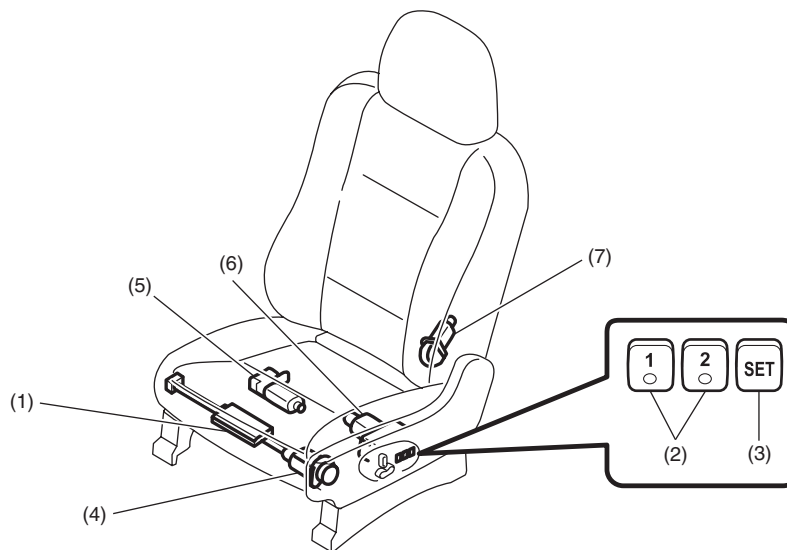

SE-00748

- | | | |
|--|-----------------------|--------------------------|
| (1) Memory unit | (4) Slide motor ASSY | (6) Tilt motor ASSY |
| (2) Preset call button
(memory switch ASSY) | (5) Lifter motor ASSY | (7) Reclining motor ASSY |
| (3) SET button
(memory switch ASSY) | | |

POWERED SEAT SYSTEM WITH MEMORY PRESET (FROM '06MY)

SEAT

1. MEMORY UNIT

In addition to storing the current slide/tilt/lifter/reclining positions based on the pulse signals from each motor assembly, registration/call out of preset seat positions is performed by the operation of the memory switch assembly.

The amount of movement for each motor is counted from a reference position, and the counts are recorded by this count. If the counts from the reference position exceeds the limit for some reason, the preset call feature may not operate properly, and initialization will be required in this case.

When a preset seat position is registered or called out, the built-in buzzer will sound.

2. MEMORY SWITCH ASSEMBLY

• SET button

When the SET button is pressed, the unit will enter the registration preparation status. (If the preset call button is not pressed within 5 seconds, the registration preparation status will be cancelled.)

• Preset call button

- Calls out the registered seat position.
- By pressing the preset call button after pressing the SET button, the seat position is registered.

3. MOTOR ASSEMBLY

A motor assembly is provided for each function of slide, tilt, lifter, and reclining.

Each motor assembly has a built-in encoder, and sends a pulse signal to the memory unit.

POWERED SEAT SYSTEM WITH MEMORY PRESET (FROM '06MY)

SEAT

C: SPECIFICATION

1. SYSTEM DIAGRAM

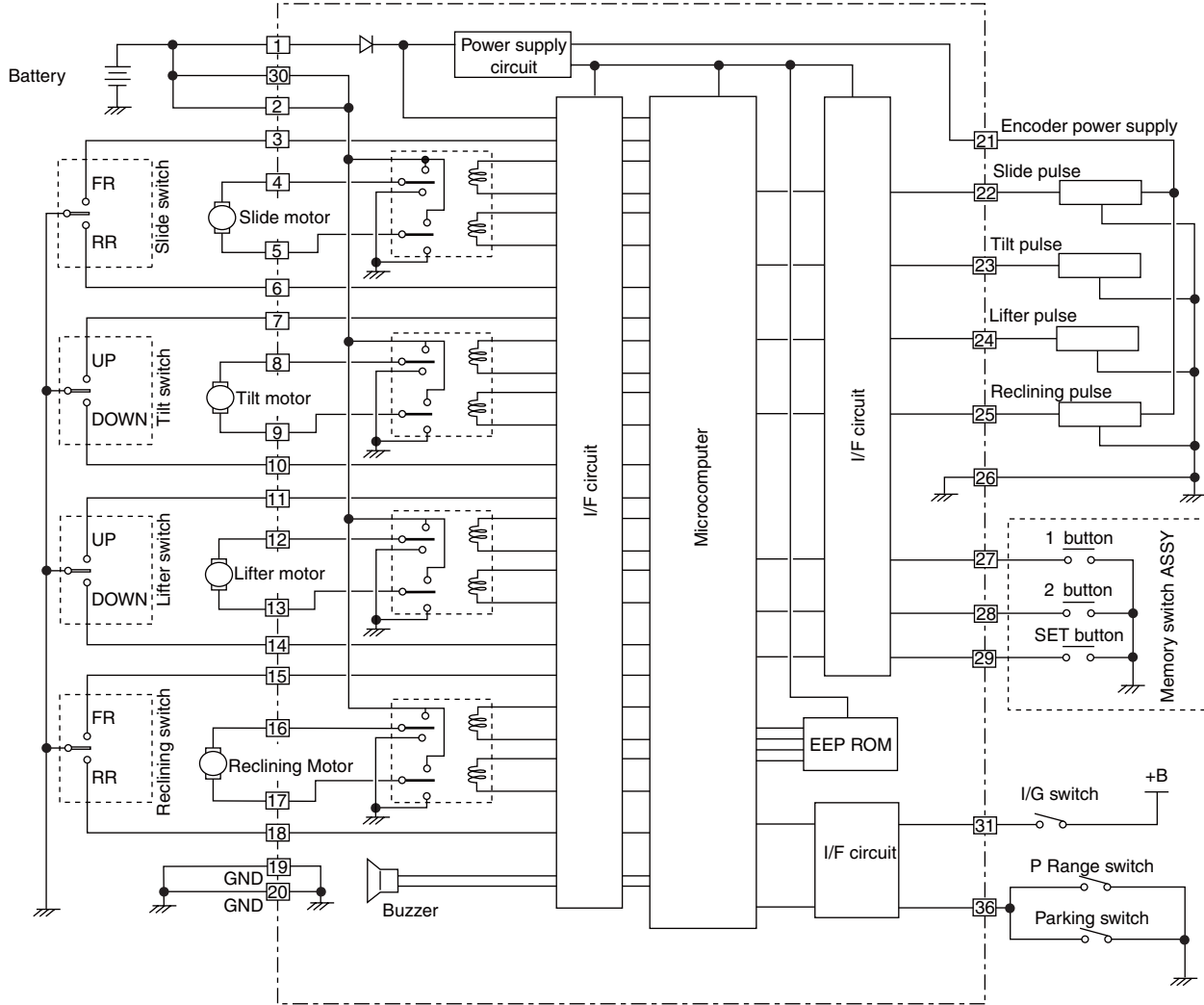

SE-00758

POWERED SEAT SYSTEM WITH MEMORY PRESET (FROM '06MY)

SEAT

2. I/O SIGNAL

DC10 to 16, -30 to +80°C

Terminal No.	Input/output name	Maximum input voltage (V)	Hi level minimum input/output voltage (V)	Low level maximum input/output voltage (V)	Maximum allowable current (A)
1	Main power supply input	16	10	—	3
2	Motor power supply 2 input	16	10	—	25
3	Slide forward switch input	—	—	1.5	50 mA
4	Slide motor forward output	16	9.5	—	23 ^{*2}
5	Slide motor reverse output	16	9.5	—	23 ^{*2}
6	Slide reverse switch input	—	—	1.5	50 mA
7	Tilt up switch input	—	—	1.5	50 mA
8	Tilt motor up output	16	9.5	—	23 ^{*2}
9	Tilt motor down output	16	9.5	—	23 ^{*2}
10	Tilt down switch input	—	—	1.5	50 mA
11	Lifter up switch input	—	—	1.5	50 mA
12	Lifter motor up output	16	9.5	—	23 ^{*2}
13	Lifter motor down output	16	9.5	—	23 ^{*2}
14	Lifter down switch input	—	—	1.5	50 mA
15	Reclining forward switch input	—	—	1.5	50 mA
16	Reclining motor forward output	16	9.5	—	25 ^{*2}
17	Reclining motor reverse output	16	9.5	—	25 ^{*2}
18	Reclining reverse switch input	—	—	1.5	50 mA
19	Main GND 1 input	—	—	—	25
20	Main GND 2 input	—	—	—	25
21	Encoder power supply output	16	8 ^{*1}	—	50 mA
22	Slide pulse input	—	—	1	50 mA
23	Tilt pulse input	—	—	1	50 mA
24	Lifter pulse input	—	—	1	50 mA
25	Reclining pulse input	—	—	1	50 mA
26	Motor pulse GND input	—	—	—	3
27	Preset call button 1 input	—	—	1	50 mA
28	Preset call button 2 input	—	—	1	50 mA
29	SET button input	—	—	1	50 mA
30	Motor power supply 1 input	16	10	—	25
31	Ignition switch input	16	10	—	3
36	Parking switch input	—	—	1.5	50 mA

*1: When current flow is 8 mA or less.

*2: When output time is 4 seconds or less (compatibility with built-in motor circuit breaker)

D: OPERATION

1. SEAT POSITION REGISTRATION

- 1) Set the seat to the optimum position.
- 2) Press the SET button, and press preset call button 1 or 2 within 5 seconds.
- 3) When the seat position is registered, the buzzer will sound once.

NOTE:

Even if the battery is removed, the registered seat position will not be deleted.

2. CALLING OUT THE PRESET SEAT POSITION

By pressing the preset call button 1 or 2, the seat will return to the registered seat position.

CAUTION:

1 The operational conditions for the preset call operation is as follows.

AT model:

Ignition switch	Selector lever	Operational condition
ON	"P" range position	Preset call allowed
ON	Other than the "P" range	Preset call prohibited
OFF	"P" range position	Preset call allowed
OFF	Other than the "P" range	Preset call allowed

MT model:

Ignition switch	Parking brake	Operational condition
ON	Applied	Preset call allowed
ON	Disengaged	Preset call prohibited
OFF	Applied	Preset call allowed
OFF	Disengaged	Preset call allowed

2 If the following is performed while performing the seat preset call, the call out operation will be cancelled.

- When power seat operation by manual switch is performed
- When preset call button 1 or 2 is pressed
- When the SET button is pressed

POWERED SEAT SYSTEM WITH MEMORY PRESET (FROM '06MY)

SEAT

3. INITIALIZATION

In relation to the reference position recorded by the memory unit, if the actual amount of seat movement does not match the pulse count, (eg. motor should only count up to 10 but counted to 11 during movement), the preset call operation may not function properly. If the registered position and the called out position differs, it is necessary to perform initialization.

NOTE:

Steps 1 to 4 may be performed in any order.

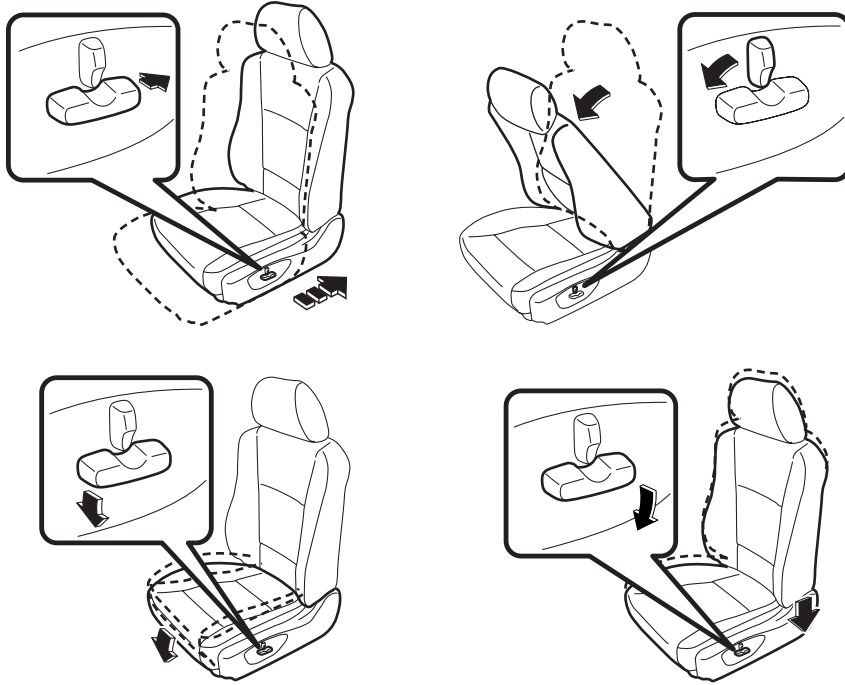

SE-00750

1. Operate the slide switch and move the seat towards the rear. Even after reaching the rearmost position, continue to operate the switch until a buzzer is heard.
2. Operate the reclining switch and move the back rest forward. Even after reaching the foremost position, continue to operate the switch until a buzzer is heard.
3. Operate the tilt switch and move the seat cushion downward. Even after reaching the lowest position, continue to operate the switch until a buzzer is heard.
4. Operate the lifter switch and move the seat cushion downward. Even after reaching the lowest position, continue to operate the switch until a buzzer is heard.
5. When the switch operation in the 4th step is turned from ON to OFF, if the initialization has been completed properly, the buzzer will sound 3 times.

NOTE:

If the following conditions occur, the initialization operation will be cancelled.

- If the interval of operations between steps 1 to 4 exceed 10 seconds
- If all operations from steps 1 to 4 are not performed
- If power is cut off during the operations of steps 1 to 4, or if the voltage to the unit falls below the operating voltage

3. Rear Seat

A: OPERATION

1. SEDAN MODELS

The backrest has an armrest. It is also featured with a “center through” function.

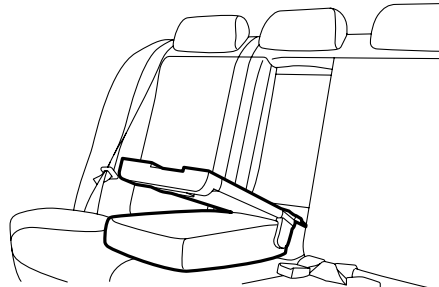

SE-00396

2. WAGON MODELS

- Unlock the backrest by pushing the release button and then fold the backrest forwards.
- The backrest and shoulder portions are separated to improve support of the rear passenger's body. The backrest is also provided with a single-action folding feature, which contributes to form a flat luggage room by folding only the backrest forwards.

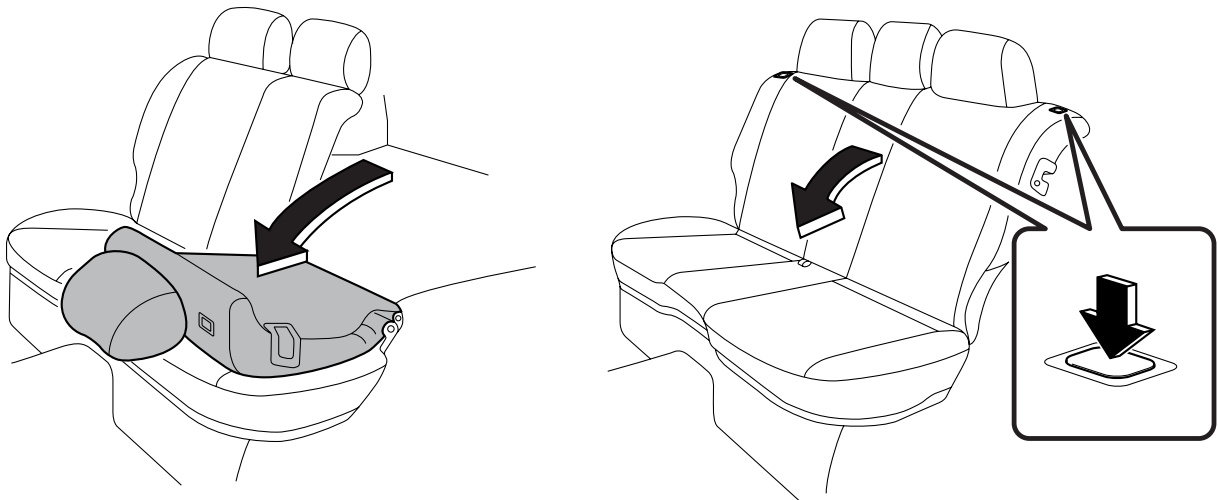

SE-00377

WALK-IN FEATURE (FROM '06MY)

SEAT

4. WALK-IN Feature (From '06MY)

A: GENERAL

A WALK-IN feature is provided on the second row seats to make it easier for the 3rd row passengers to get in and out of the vehicle.

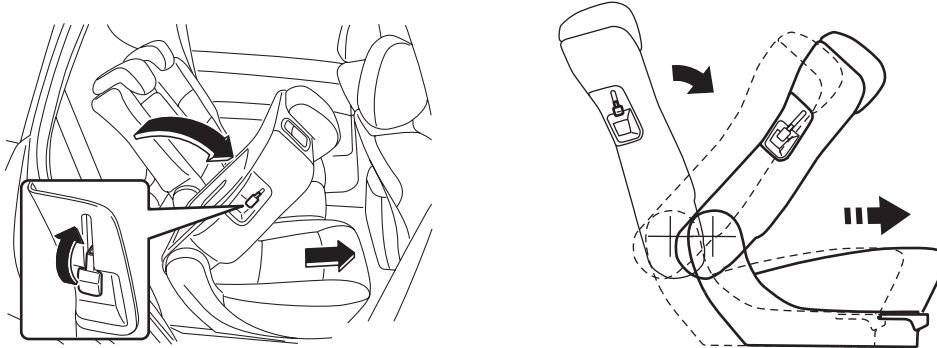

SE-00752

B: MECHANISM

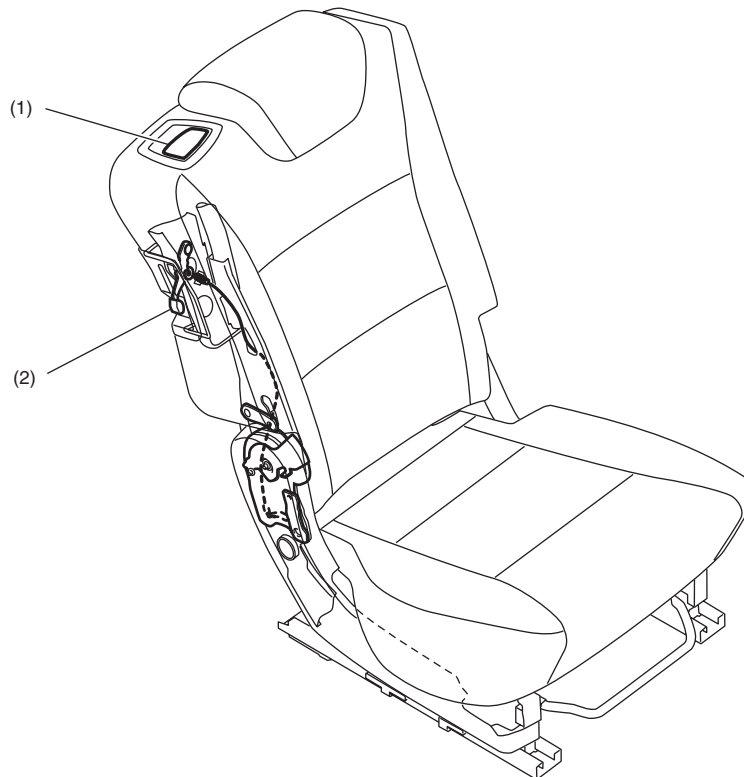

SE-00753

(1) Reclining lever

(2) WALK-IN lever

Brought to you by Eris Studios
NOT FOR RESALE

C: FUNCTION

1. FOLDING

When the WALK-IN lever is operated, the recliner is released through a wire inside the seat, and the seat backrest will fold forward. This will press the WALK-IN bracket against the lock plate, and rotate centered on the hinge center, pulling the slide release cable, and the seat slide lock will be released.

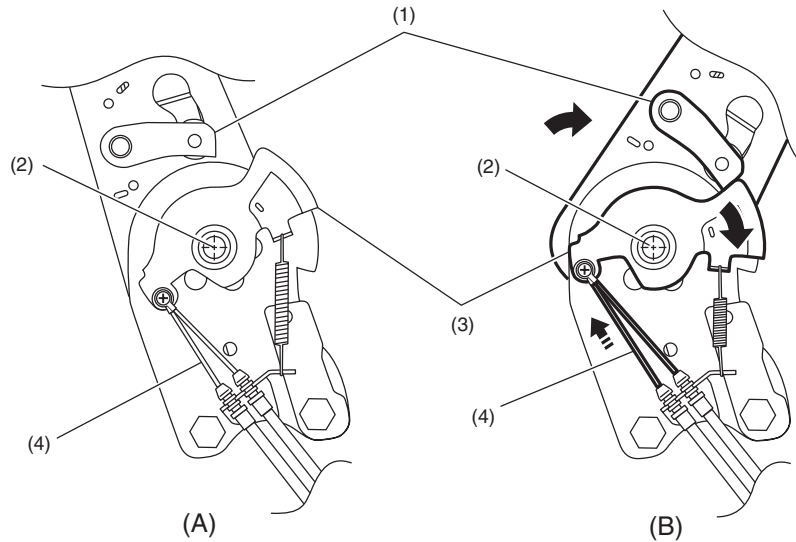

SE-00754

(A) When locked

(B) When folded

(1) Lock plate
(2) Hinge center

(3) WALK-IN bracket

(4) Slide release cable

2. WHEN FOLDED FORWARD

When the reclining lever is operated, the lock plate is pulled up with the wire. The pulled up lock plate is maintained at that position, and it will become possible to fold forward.

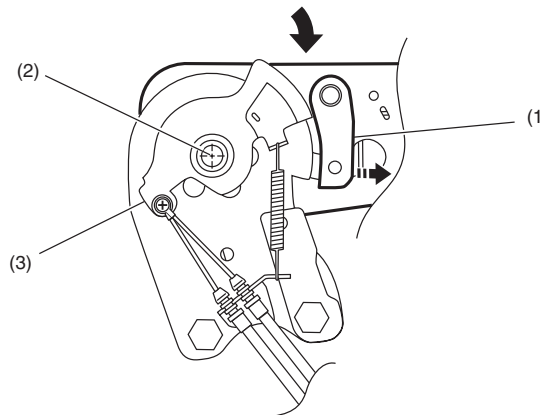

SE-00755

(1) Lock plate

(2) Hinge center

(3) WALK-IN bracket

OCCUPANT DETECTION SYSTEM (UNTIL '05MY)

SEAT

5. Occupant Detection System (Until '05MY)

A: GENERAL

The passenger's seat is equipped with an occupant detection system, which consists of an occupant detection control module and four loadcell sensors, etc.

The occupant detection system sends signals to control the deployment of the passenger's seat air-bag when a child or small person is sitting in the passenger's seat.

B: SYSTEM CONFIGURATION

The components of the occupant detection system are integrated as a seat cushion frame assembly; the assembly cannot be disassembled and the components cannot be replaced separately.

1. OCCUPANT DETECTION CONTROL MODULE

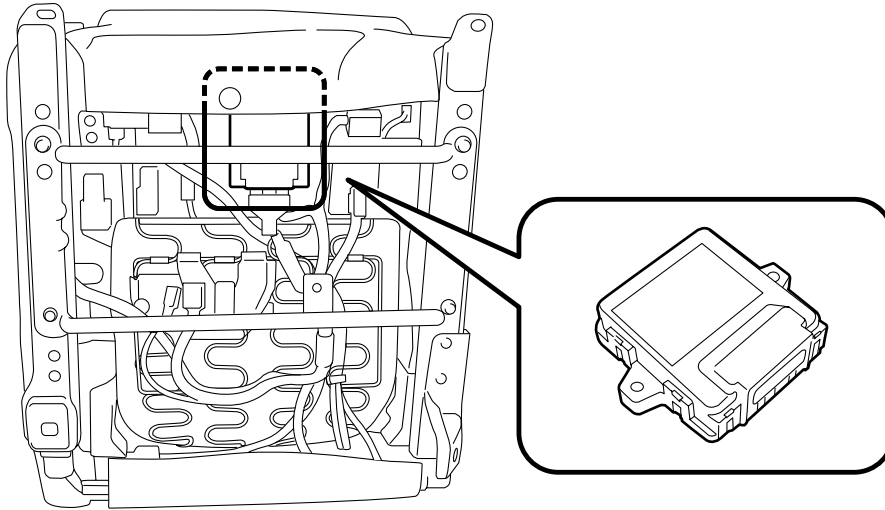

SE-00475

The occupant detection control module is installed under the passenger's seat and detects the presence/absence and physique of the person sitting in the passenger's seat based on signals sent from the loadcell sensors to send signals to the airbag control module.

If there is any abnormality in the occupant detection control module, the airbag warning light in the combination meter illuminates to warn the driver of system abnormality. Diagnostic trouble codes can be read by using a Subaru select monitor.

2. LOADCELL SENSOR

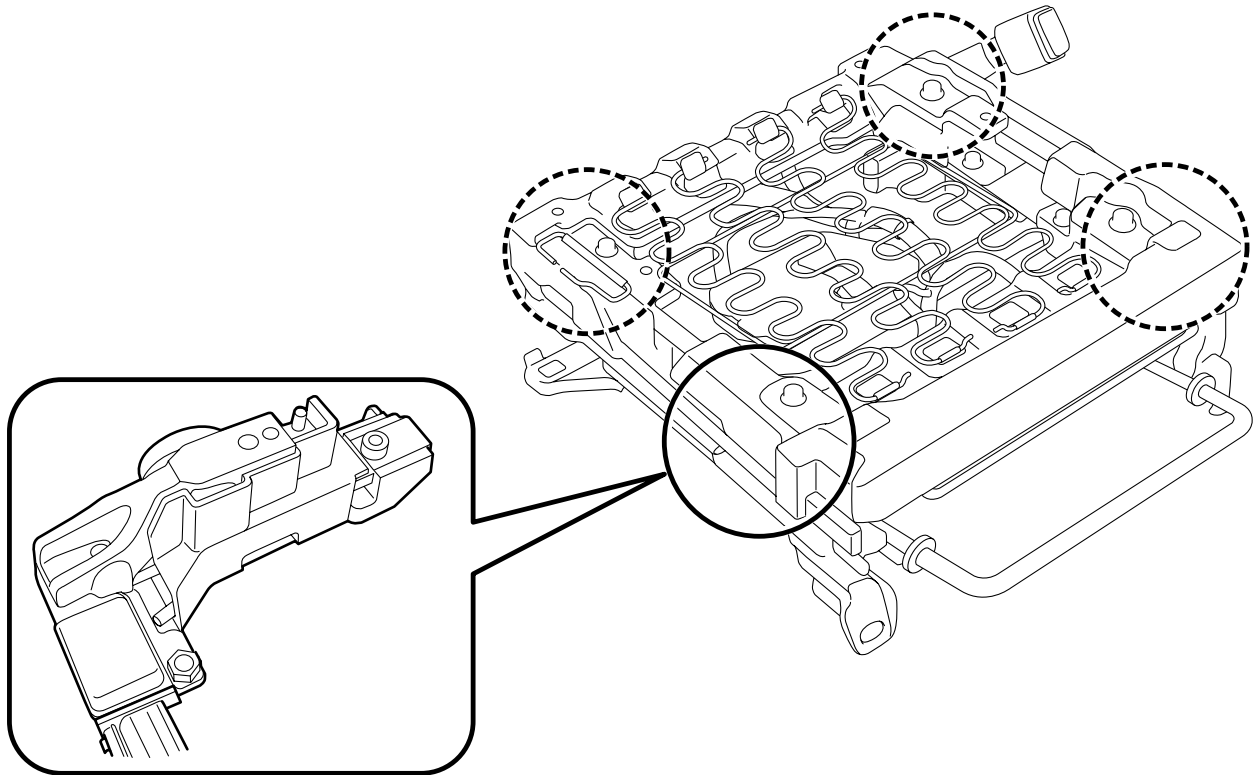

SE-00476

Four loadcell sensors are installed on the passenger's seat and each sensor measures the load to send signals to the load occupant detection control module.

OCCUPANT DETECTION SYSTEM (UNTIL '05MY)

SEAT

3. PASSENGER'S SEAT AIRBAG INDICATOR

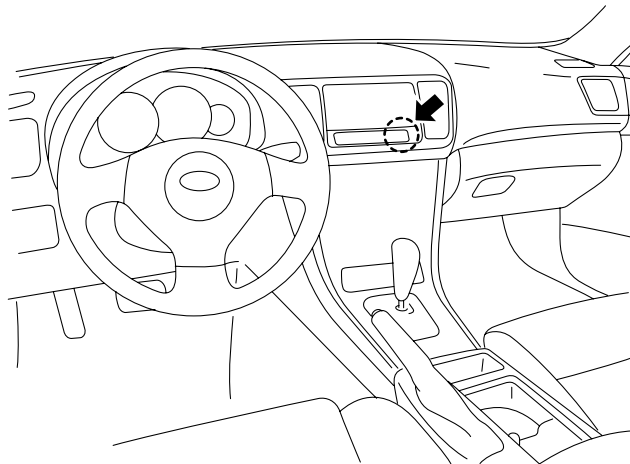

SE-00477

The passenger's seat airbag indicator light is built in the center part of the instrument panel. The light indicates the result judged by the occupant detection control module.

Depending on the occupant detection control module's decision, the passenger's seat airbag may not deploy even in case of a frontal collision, however, the driver's seat airbag will deploy and the driver/passenger seat belt pretensioners are controlled to activate. Also, the driver/passenger seat side airbags and the left/right curtain airbags are controlled to activate.

For initial check of the occupant detection system, both the ON (will deploy) and OFF (will not deploy) indicators will illuminate for about 6 seconds after the ignition switch is turned ON, and then turns OFF simultaneously for 2 seconds.

6. Occupant Detection System (From '06MY)

A: GENERAL

In '06MY, the occupant detection system was changed. The loadcell sensor that is located between the seat cushion and the seat frame consists of the bladder (bag) containing silicon gel and the pressure sensor connected with a hose. When the passenger sits in the passenger's seat, the silicon gel contained in the bladder is pushed. The loadcell sensor measures this pressure, and then it sends the signal to the occupant detection control module. The occupant detection control module detects the physique of the person sitting in the passenger's seat based on the signals, and then it sends the control signal to the airbag control module.

The belt tension sensor was also added to the outer seat belt. The belt tension sensor detects the status that seat belt is continuously tensioning (when the child seat is attached to the passenger's seat, etc.), and then it sends the signal to the occupant detection control module.

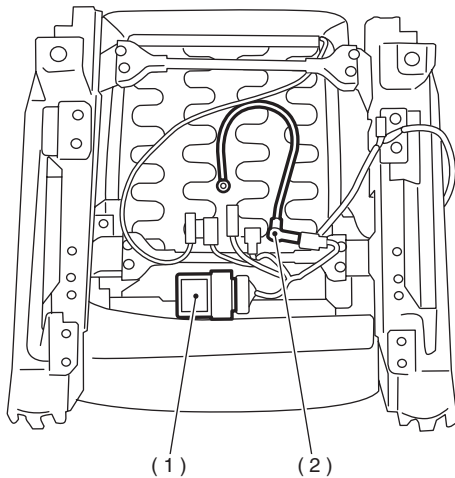

SE-00666

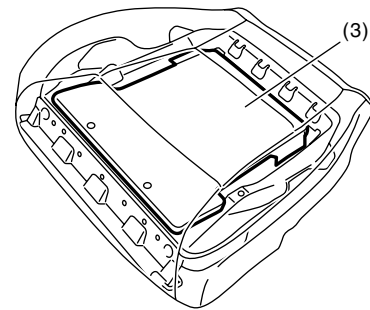

SE-00667

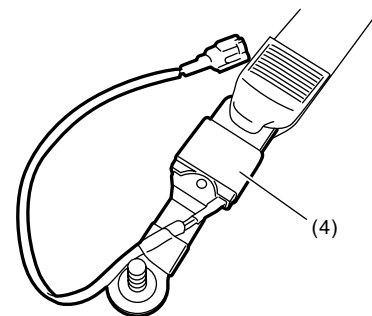

SE-00668

- (1) Occupant detection control module
- (2) Loadcell sensor
- (3) Bladder (with silicon gel)
- (4) Belt tension sensor