

Brought to you by Eris Studios
NOT FOR RESALE

MANUAL TRANSMISSION AND DIFFERENTIAL 5-SPEED (5MT)

General Description

MANUAL TRANSMISSION AND DIFFERENTIAL

1. General Description

A: SPECIFICATION

1. MANUAL TRANSMISSION AND DIFFERENTIAL

Model		2.5 L	
		2.5i, OUTBACK	
		2.5 L Turbo	
Type		5-forward speeds with synchromesh and 1-reverse	
Transmission gear ratio		1st	3.454
		2nd	2.062
		3rd	1.448
		4th	1.088
		5th	0.780
		Reverse	3.333
Front reduction gear	Final	Type of gear	Hypoid
		Gear ratio	3.900
Rear reduction gear	Transfer	Type of gear	Helical
		Gear ratio	1.000
	Final	Type of gear	Hypoid
		Gear ratio	3.900
Front differential	Type and number of gear		Straight bevel gear (Bevel pinion: 2, Bevel gear: 2)
Center differential	Type and number of gear		Straight bevel gear (Bevel pinion: 2, bevel gear: 2 and viscous coupling)
Transmission gear oil		GL-5	
Transmission gear oil capacity		3.5 ℓ (3.7 US qt, 3.1 Imp qt)	

2. TRANSMISSION GEAR OIL

Recommended oil:

GL-5 (75W-90) or equivalent

3. TRANSMISSION CASE ASSEMBLY

Drive pinion shim adjustment

Hypoid gear backlash:

0.13 — 0.18 mm (0.0051 — 0.0071 in)

Drive pinion shim			
Part No.	Thickness mm (in)	Part No.	Thickness mm (in)
32295AA031	0.150 (0.0059)	32295AA071	0.250 (0.0098)
32295AA041	0.175 (0.0069)	32295AA081	0.275 (0.0108)
32295AA051	0.200 (0.0079)	32295AA091	0.300 (0.0118)
32295AA061	0.225 (0.0089)	32295AA101	0.500 (0.0197)

Selection of main shaft rear plate

Main shaft rear plate		
Dimension "A" mm (in)	Part No.	Mark
4.00 — 4.13 (0.1575 — 0.1626)	32294AA041	1
3.87 — 3.99 (0.1524 — 0.1571)	32294AA051	2

4. DRIVE PINION ASSEMBLY

Preload adjustment of thrust bearing

Starting torque:

0.3 — 0.8 N·m (0.03 — 0.08 kgf·m, 0.2 — 0.6 ft·lb)

Adjusting washer No. 1	
Part No.	Thickness mm (in)
803025051	3.925 (0.1545)
803025052	3.950 (0.1555)
803025053	3.975 (0.1565)
803025054	4.000 (0.1575)
803025055	4.025 (0.1585)
803025056	4.050 (0.1594)
803025057	4.075 (0.1604)

Adjusting washer No. 2	
Part No.	Thickness mm (in)
803025059	3.850 (0.1516)
803025054	4.000 (0.1575)
803025058	4.150 (0.1634)

5. REVERSE IDLER GEAR

Adjustment of reverse idler gear position

Reverse idler gear to transmission case (LH) wall clearance:

6.0 — 7.5 mm (0.236 — 0.295 in)

Reverse shifter lever		
Part No.	Mark	Remarks
32820AA070	7	Further from case wall
32820AA080	8	Standard
32820AA090	9	Closer to the case wall

After installing a suitable reverse shifter lever, adjust the clearance using washers.

Reverse idler gear to transmission case wall clearance:

0 — 0.5 mm (0 — 0.020 in)

Washer (20.5 × 26 × t)			
Part No.	Thickness mm (in)	Part No.	Thickness mm (in)
803020151	0.4 (0.016)	803020154	1.9 (0.075)
803020152	1.1 (0.043)	803020155	2.3 (0.091)
803020153	1.5 (0.059)	—	—

6. SHIFTER FORK AND ROD

Select a suitable shifter fork so that both the coupling sleeve and reverse driven gear are positioned in the center of their synchromesh mechanisms.

Rod end clearance:

A: 1st-2nd — 3rd-4th

0.4 — 1.4 mm (0.016 — 0.055 in)

B: 3rd-4th — 5th

0.5 — 1.3 mm (0.020 — 0.051 in)

1st-2nd shifter fork		
Part No.	Mark	Remarks
32804AA060	1	Approaches 1st gear by 0.2 mm (0.008 in).
32804AA070	No mark	Standard
32804AA080	3	Approaches 2nd gear by 0.2 mm (0.008 in)

3rd-4th shifter fork		
Part No.	Mark	Remarks
32810AA061	1	Approaches 4th gear by 0.2 mm (0.008 in).
32810AA071	No mark	Standard
32810AA101	3	Approaches 3rd gear by 0.2 mm (0.008 in)

5th shifter fork (Non-turbo model), Identification paint (pink)		
Part No.	Mark	Remarks
32812AA201	7	Approaches 5th gear by 0.2 mm (0.008 in).
32812AA211	No mark	Standard
32812AA221	9	Moves away from 5th gear by 0.2 mm (0.008 in).

5th shifter fork (Turbo model), Identification paint (blue)		
Part No.	Mark	Remarks
32812AA231	7	Approaches 5th gear by 0.2 mm (0.008 in).
32812AA241	No mark	Standard
32812AA251	9	Moves away from 5th gear by 0.2 mm (0.008 in).

7. TRANSFER CASE OR REAR CASE

Neutral position adjustment

Adjusting shim	
Part No.	Thickness mm (in)
32190AA000	0.15 (0.0059)
32190AA010	0.30 (0.0118)

Reverse accent shaft		
Part No.	Mark	Remarks
32188AA130	S	Neutral position is closer to 1st.
32188AA140	T	Standard
32188AA150	U	Neutral position is closer to reverse gear.

Reverse check plate adjustment

Reverse check plate			
Part No.	Mark	Angle θ	Remarks
32189AA000	0	28°	Arm stops closer to 5th gear.
32189AA010	1	31°	Arm stops closer to 5th gear.
33189AA020	2	34°	Arm stops in the center.
32189AA030	3	37°	Arm stops closer to reverse gear.
32189AA040	4	40°	Arm stops closer to reverse gear.

General Description

MANUAL TRANSMISSION AND DIFFERENTIAL

8. EXTENSION ASSEMBLY

Taper roller bearing preload (standard protrusion) :

0.2 — 0.3 mm (0.008 — 0.012 in)

NOTE:

Always adjust to the specified range of preload.

Thrust washer (50 × 61 × t)	
Part No.	Thickness mm (in)
803050060	0.50 (0.0197)
803050061	0.55 (0.0217)
803050062	0.60 (0.0236)
803050063	0.65 (0.0256)
803050064	0.70 (0.0276)
803050065	0.75 (0.0295)
803050066	0.80 (0.0315)
803050067	0.85 (0.0335)
803050068	0.90 (0.0354)
803050069	0.95 (0.0374)
803050070	1.00 (0.0394)
803050071	1.05 (0.0413)
803050072	1.10 (0.0433)
803050073	1.15 (0.0453)
803050074	1.20 (0.0472)
803050075	1.25 (0.0492)
803050076	1.30 (0.0512)
803050077	1.35 (0.0531)
803050078	1.40 (0.0551)
803050079	1.45 (0.0571)

Thrust washer to center differential side clearance:

0.15 — 0.35 mm (0.0059 — 0.0138 in)

Thrust washer	
Part No.	Thickness mm (in)
803036050	0.9 (0.035)
803036054	1.0 (0.039)
803036051	1.1 (0.043)
803036055	1.2 (0.047)
803036052	1.3 (0.051)
803036056	1.4 (0.055)
803036053	1.5 (0.059)
803036057	1.6 (0.063)
803036058	1.7 (0.067)

9. FRONT DIFFERENTIAL

Bevel gear to pinion backlash:

0.13 — 0.18 mm (0.0051 — 0.0071 in)

Washer (38.1 × 50 × t)			
Part No.	Thickness mm (in)	Part No.	Thickness mm (in)
803038021	0.925 — 0.950 (0.0364 — 0.0374)	803038023	1.025 — 1.050 (0.0404 — 0.0413)
803038022	0.975 — 1.000 (0.0384 — 0.0394)	—	—

Pinion shaft to axle drive shaft clearance:

0 — 0.2 mm (0 — 0.008 in)

Snap ring (Outer-28)			
Part No.	Thickness mm (in)	Part No.	Thickness mm (in)
805028011	1.05 (0.0413)	805028012	1.20 (0.0472)

10. TRANSFER DRIVE GEAR

Snap ring (Outer-30) to ball bearing clearance:

0.01 — 0.15 mm (0.0004 — 0.0059 in)

Snap ring (Outer-30)	
Part No.	Thickness mm (in)
805030041	1.53 (0.0602)
805030042	1.65 (0.0650)
805030043	1.77 (0.0697)

General Description

MANUAL TRANSMISSION AND DIFFERENTIAL

B: COMPONENT

1. TRANSMISSION CASE

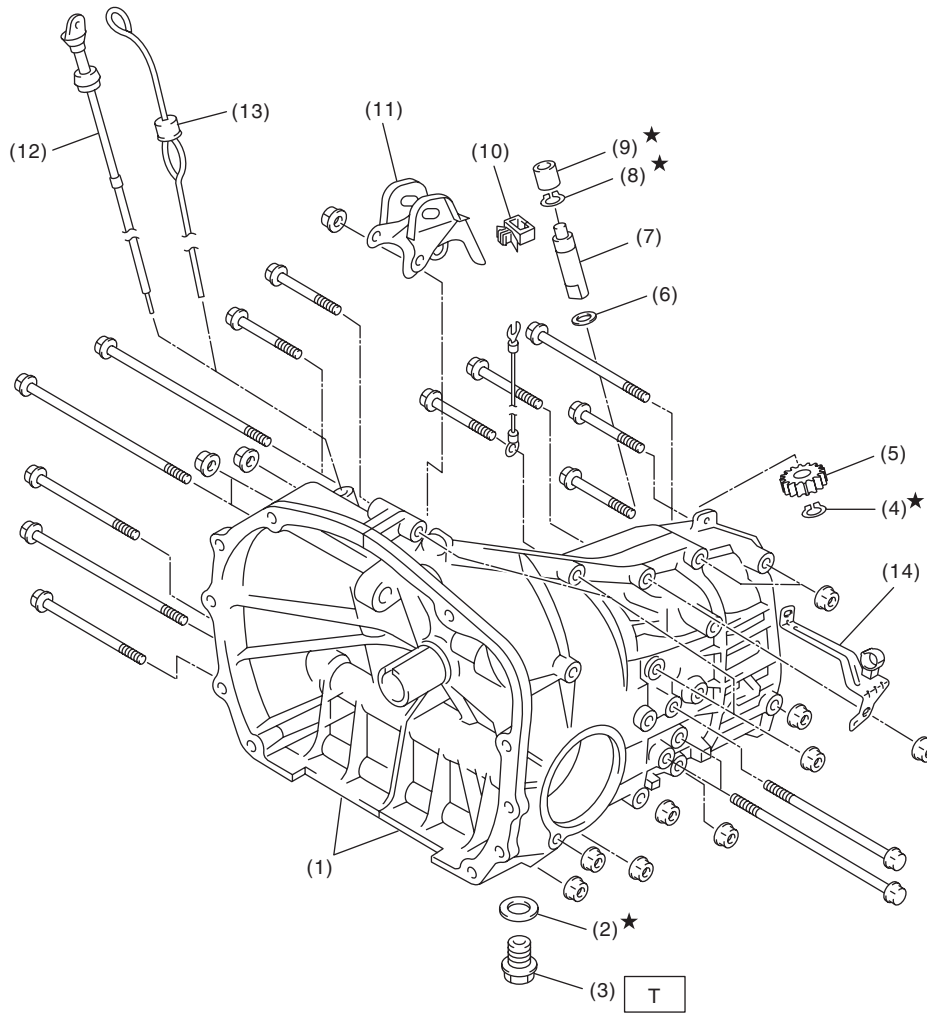

MT-00974

General Description

MANUAL TRANSMISSION AND DIFFERENTIAL

- | | | |
|-----------------------------|--|--|
| (1) Transmission case ASSY | (8) Snap ring (Outer) | (14) Harness bracket (Non-turbo model) |
| (2) Gasket | (9) Oil seal | |
| (3) Drain plug | (10) Clamp | |
| (4) Snap ring (Outer) | (11) Pitching stopper bracket | |
| (5) Speedometer driven gear | (12) Oil level gauge (Non-turbo model) | |
| (6) Washer | (13) Oil level gauge (Turbo model) | |
| (7) Speedometer shaft | | |

Tightening torque: N·m (kgf-m, ft-lb)

**T: 44 (4.5, 32.5) (Aluminum gasket)
70 (7.1, 51.6) (Copper gasket)**

Transmission case tightening torque:

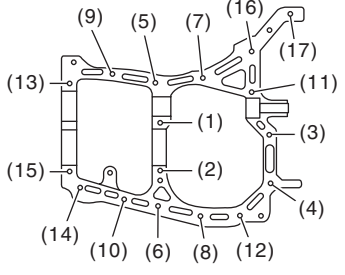
 <p style="text-align: right; margin-top: 10px;">MT-00003</p>	Bolt No.	Bolt size mm	Tightening torque N·m (kgf-m, ft-lb)
	(5) — (15)	8	25 (2.5, 18.4)
	(1) — (4) (16), (17)	10	39 (4.0, 28.9)

General Description

2. DRIVE PINION ASSEMBLY

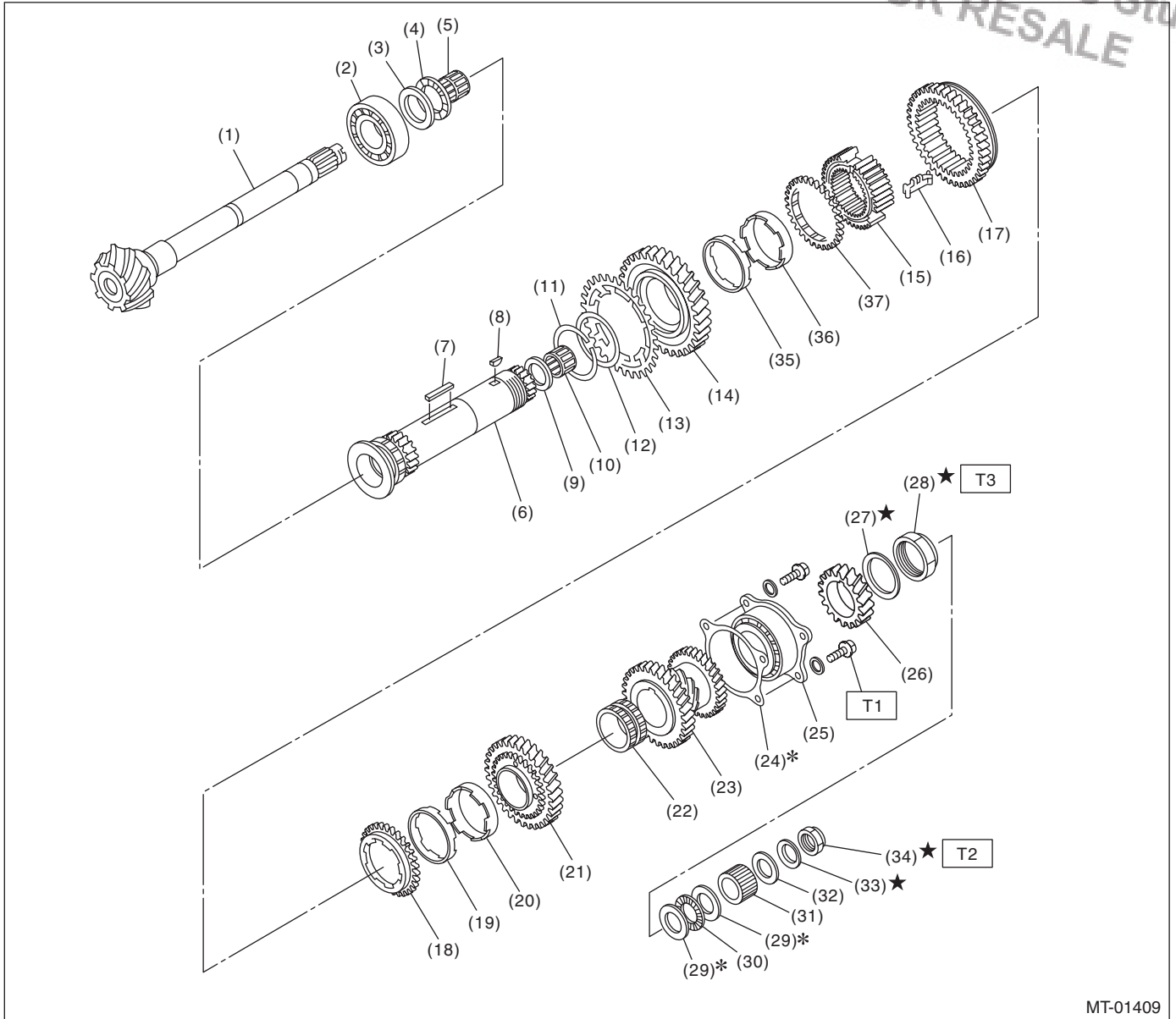

MT-01409

- | | | |
|---|-------------------------------|-------------------------------------|
| (1) Drive pinion shaft | (15) 1st-2nd synchronizer hub | (29) Adjusting washer |
| (2) Roller bearing | (16) Insert key | (30) Thrust bearing |
| (3) Washer | (17) Reverse driven gear | (31) Differential bevel gear sleeve |
| (4) Thrust bearing | (18) Outer baulk ring | (32) Washer |
| (5) Needle bearing | (19) Synchro cone | (33) Lock washer |
| (6) Driven shaft | (20) Inner baulk ring | (34) Lock nut |
| (7) Key | (21) 2nd driven gear | (35) Inner baulk ring |
| (8) Woodruff key | (22) 2nd driven gear bushing | (36) Synchro cone |
| (9) Drive pinion collar | (23) 3rd-4th driven gear | (37) Outer baulk ring |
| (10) Needle bearing | (24) Driven pinion shim | |
| (11) Snap ring (Outer)
(Non-turbo model) | (25) Roller bearing | |
| (12) Washer (Non-turbo model) | (26) 5th driven gear | |
| (13) Sub gear (Non-turbo model) | (27) Lock washer | |
| (14) 1st driven gear | (28) Lock nut | |

Tightening torque: N·m (kgf·m, ft·lb)

T1: 30 (3.1, 22.1)

T2: 120 (12.2, 88.5)

T3: 260 (26.5, 191.8)

General Description

MANUAL TRANSMISSION AND DIFFERENTIAL

3. MAIN SHAFT ASSEMBLY

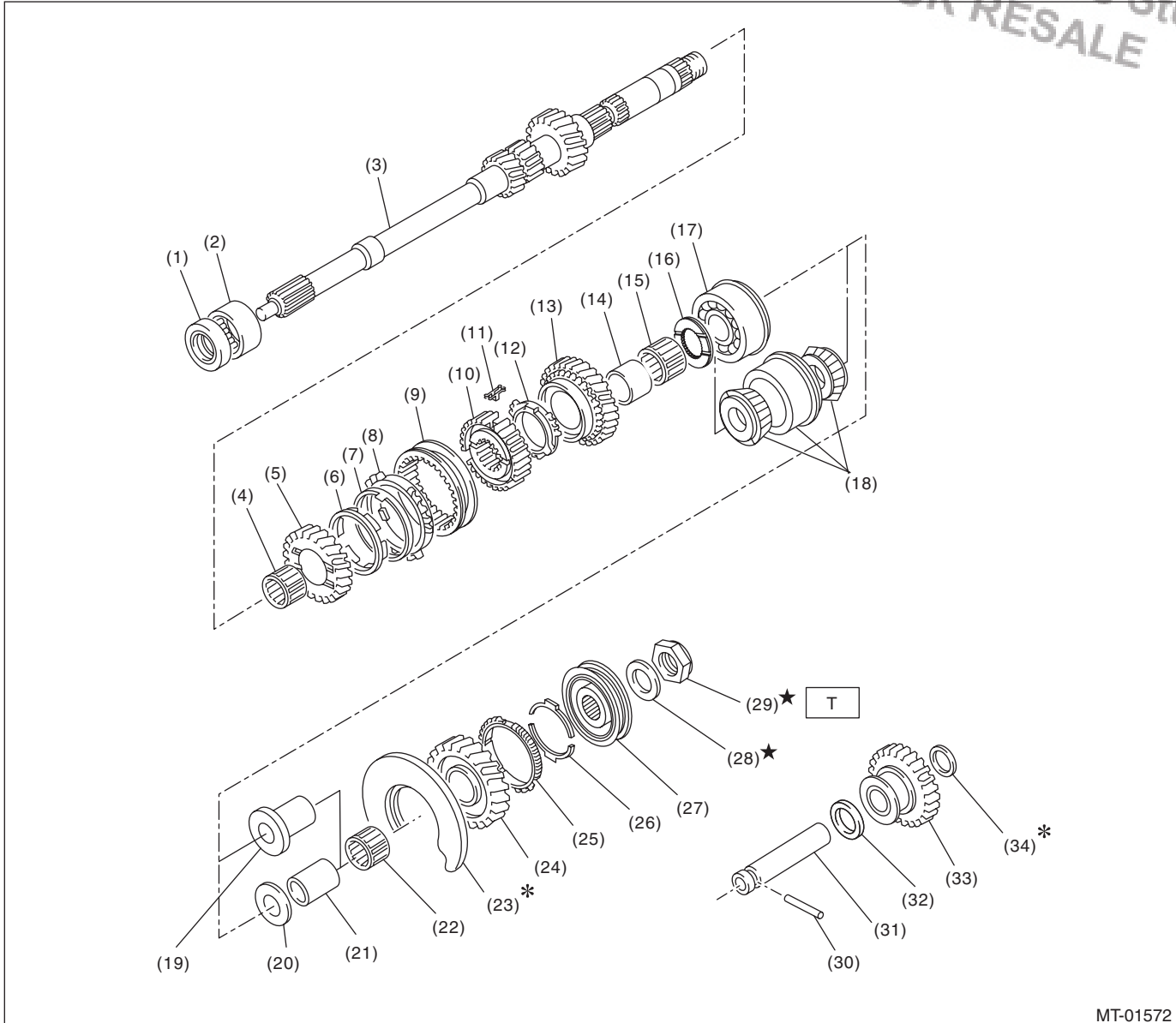

MT-01572

- | | | |
|----------------------------------|--|-------------------------------|
| (1) Oil seal | (15) Needle bearing | (25) 5th baulk ring |
| (2) Needle bearing | (16) 4th gear thrust washer | (26) Baulk lever |
| (3) Transmission main shaft | (17) Ball bearing (Non-turbo model) | (27) 5th hub & sleeve No. 2 |
| (4) Needle bearing | (18) Taper roller bearing (Turbo model) | (28) Lock washer |
| (5) 3rd drive gear | (19) 5th needle bearing race (Turbo model) | (29) Lock nut |
| (6) Inner baulk ring | (20) 5th gear thrust washer (Non-turbo model) | (30) Straight pin |
| (7) 3rd synchro cone | (21) 5th needle bearing race (Non-turbo model) | (31) Reverse idler gear shaft |
| (8) Outer baulk ring | (22) Needle bearing | (32) Washer |
| (9) 3rd-4th coupling sleeve | (23) Main shaft rear plate | (33) Reverse idler gear |
| (10) 3rd-4th synchronizer hub | (24) 5th drive gear | (34) Washer |
| (11) 3rd-4th shifting insert key | | |
| (12) 4th baulk ring | | |
| (13) 4th drive gear | | |
| (14) 4th needle bearing race | | |

Tightening torque: N·m (kgf·m, ft·lb)
T: 120 (12.2, 88.5)

General Description

MANUAL TRANSMISSION AND DIFFERENTIAL

4. SHIFTER FORK AND SHIFTER ROD

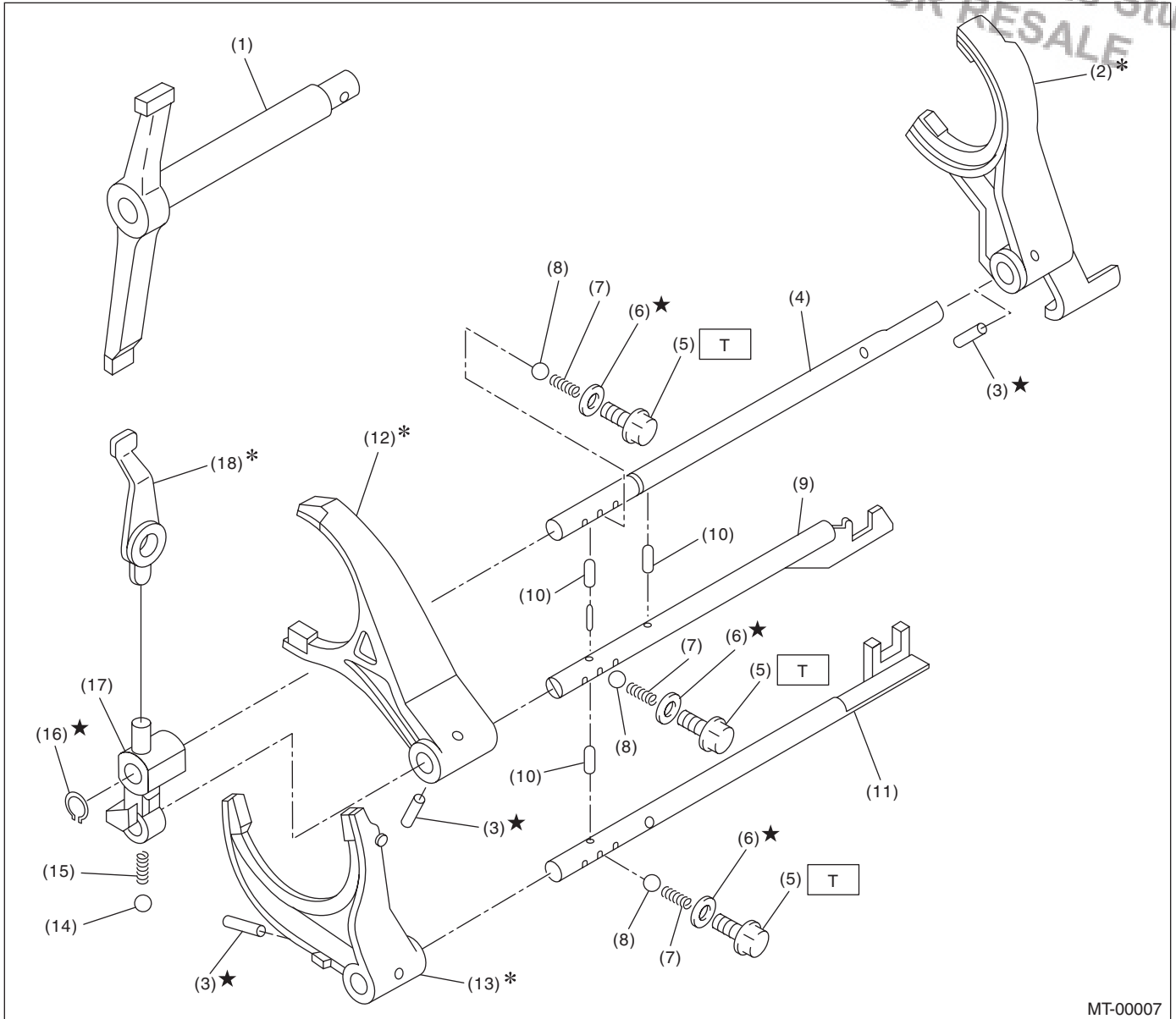

MT-00007

- | | | |
|--------------------------|---------------------------|----------------------------|
| (1) Shifter arm | (8) Ball | (15) Spring |
| (2) 5th shifter fork | (9) 3rd-4th fork rod | (16) Snap ring (Outer) |
| (3) Straight pin | (10) Interlock plunger | (17) Reverse fork rod arm |
| (4) Reverse fork rod | (11) 1st-2nd fork rod | (18) Reverse shifter lever |
| (5) Checking ball plug | (12) 3rd-4th shifter fork | |
| (6) Gasket | (13) 1st-2nd shifter fork | |
| (7) Checking ball spring | (14) Ball | |

Tightening torque: N·m (kgf·m, ft·lb)

T: 20 (2.0, 14.8)

General Description

MANUAL TRANSMISSION AND DIFFERENTIAL

5. TRANSFER CASE AND EXTENSION

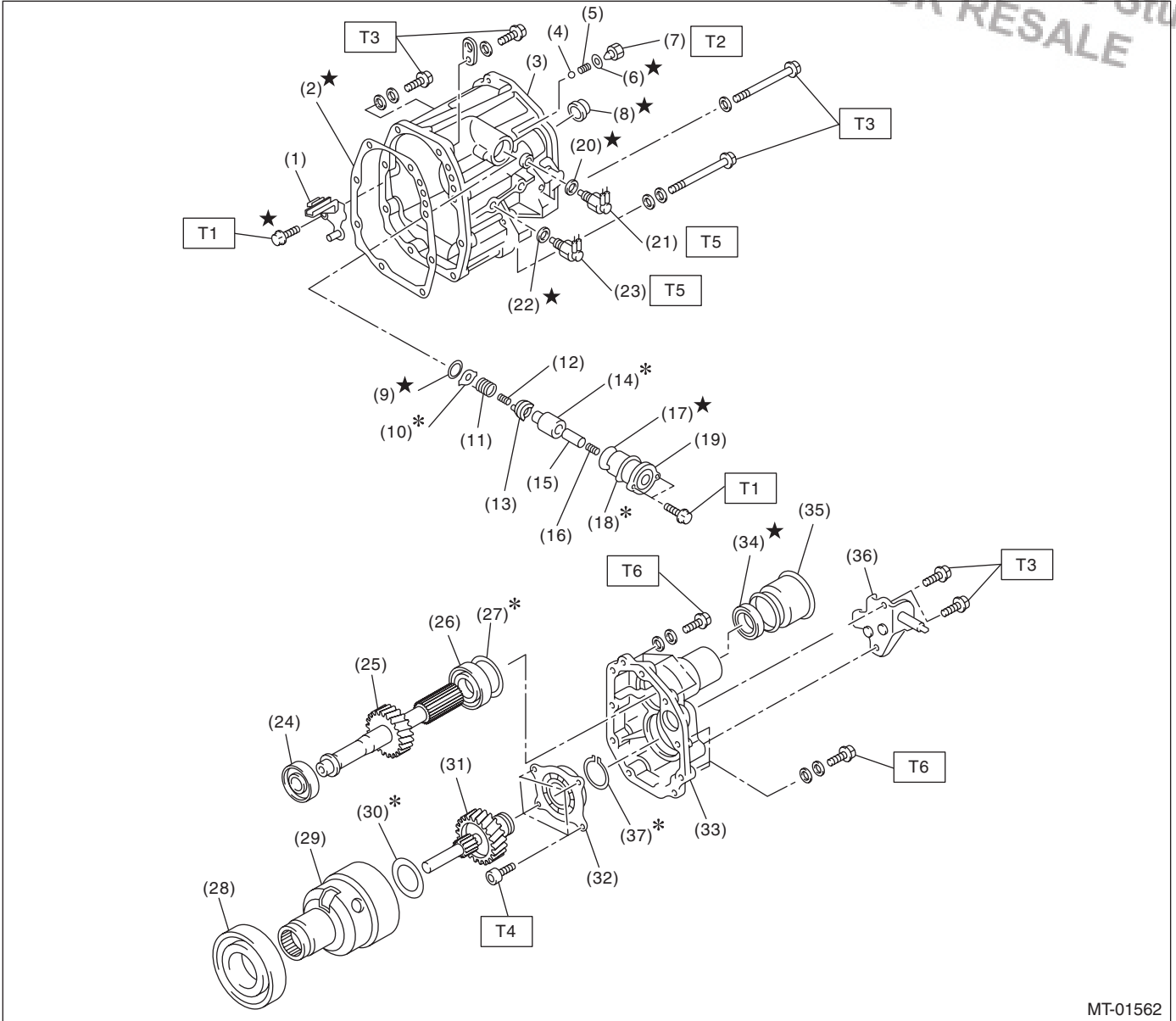

MT-01562

- | | | |
|----------------------------|------------------------------|--------------------------|
| (1) Oil guide | (16) Return spring | (31) Transfer drive gear |
| (2) Gasket | (17) O-ring | (32) Ball bearing |
| (3) Transfer case | (18) Adjusting select shim | (33) Extension case |
| (4) Ball | (19) Reverse check sleeve | (34) Oil seal |
| (5) Reverse accent spring | (20) Gasket | (35) Dust cover |
| (6) Gasket | (21) Neutral position switch | (36) Shift bracket |
| (7) Plug | (22) Gasket | (37) Snap ring |
| (8) Oil seal | (23) Back-up light switch | |
| (9) Snap ring (Inner) | (24) Roller bearing | |
| (10) Reverse check plate | (25) Transfer driven gear | |
| (11) Reverse check spring | (26) Roller bearing | |
| (12) Reverse return spring | (27) Adjusting washer | |
| (13) Reverse check cam | (28) Ball bearing | |
| (14) Reverse accent shaft | (29) Center differential | |
| (15) Return spring cap | (30) Adjusting washer | |

Tightening torque: N·m (kgf·m, ft·lb)

T1: 6.4 (0.65, 4.7)

T2: 9.75 (1.0, 7.2)

T3: 24.5 (2.5, 18.1)

T4: 26 (2.7, 20)

T5: 32.3 (3.3, 23.8)

T6: 40 (4.1, 29.7)

6. FRONT DIFFERENTIAL

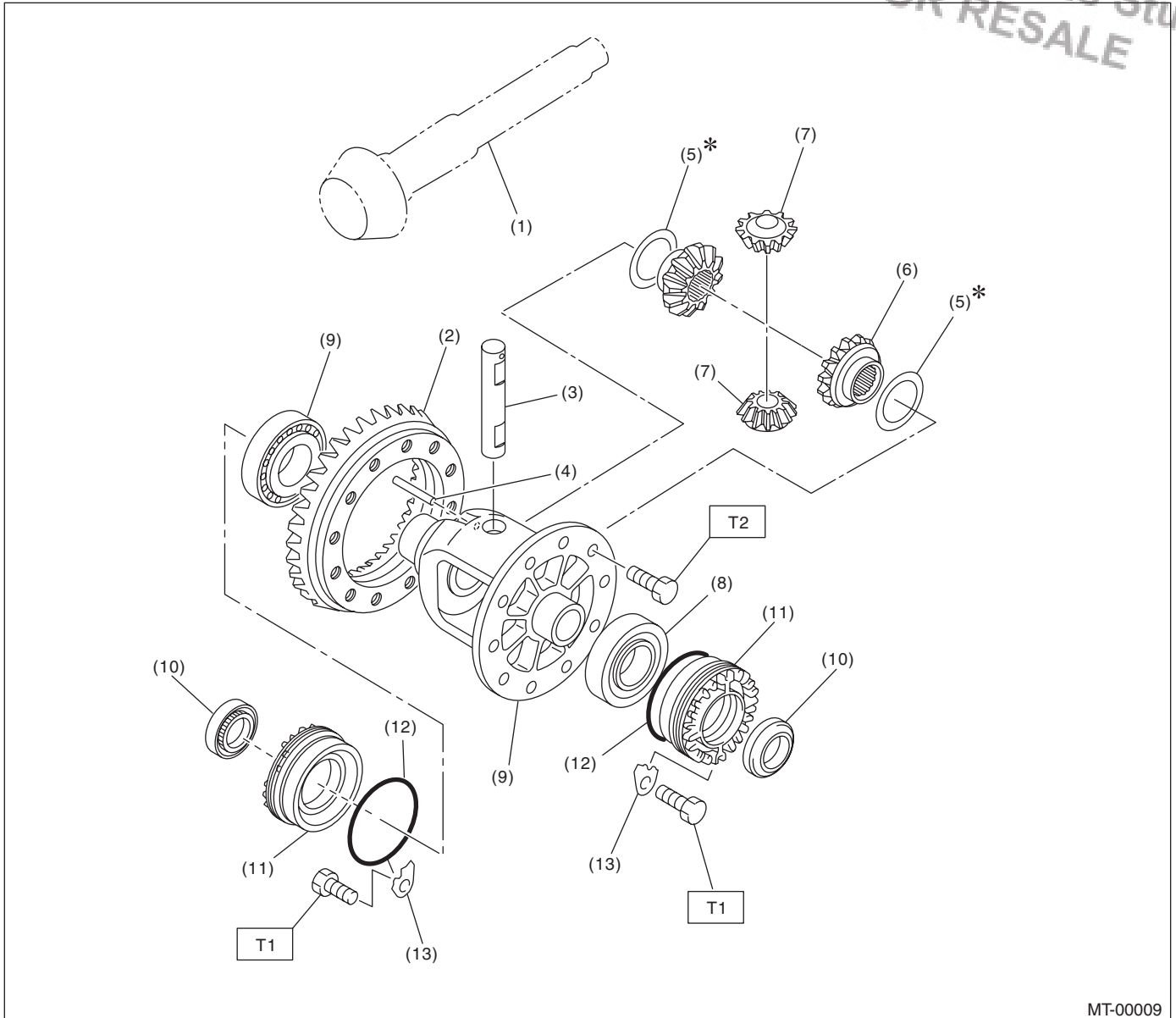

MT-00009

- | | | |
|-----------------------------|---------------------------------|--------------------------|
| (1) Drive pinion shaft | (7) Differential bevel pinion | (13) Retainer lock plate |
| (2) Hypoid driven gear | (8) Roller bearing | |
| (3) Pinion shaft | (9) Differential case | |
| (4) Straight pin | (10) Oil seal | |
| (5) Washer | (11) Differential side retainer | |
| (6) Differential bevel gear | (12) O-ring | |

Tightening torque: N·m (kgf·m, ft·lb)

T1: 25 (2.5, 18.4)

T2: 62 (6.3, 45.6)

General Description

MANUAL TRANSMISSION AND DIFFERENTIAL

7. TRANSMISSION MOUNTING

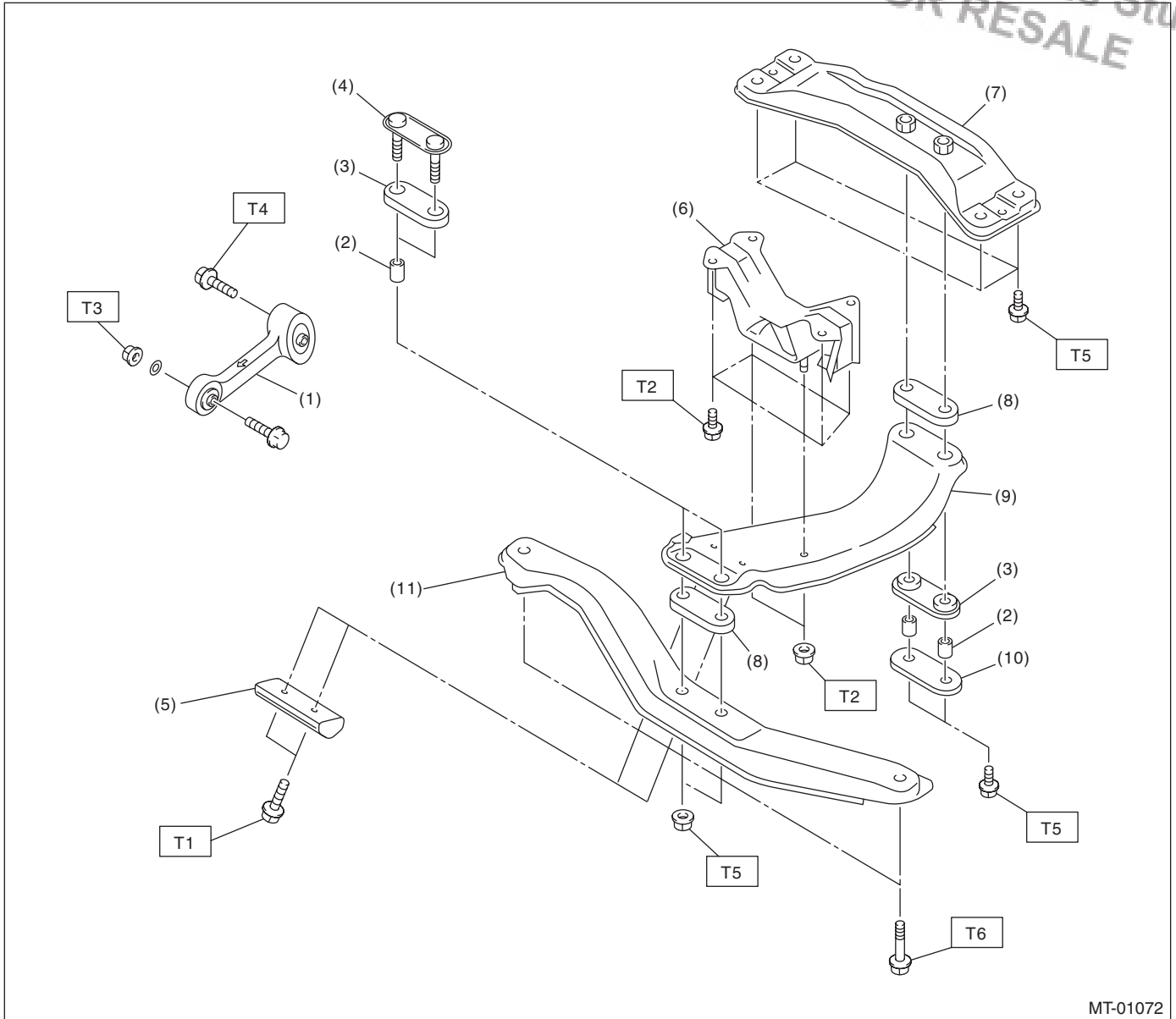

MT-01072

- | | |
|---------------------------------|--------------------------|
| (1) Pitching stopper | (8) Upper cushion rubber |
| (2) Spacer | (9) Center crossmember |
| (3) Lower cushion rubber | (10) Rear plate |
| (4) Front plate | (11) Front crossmember |
| (5) Dynamic damper | |
| (6) Transmission cushion rubber | |
| (7) Rear crossmember | |

Tightening torque: N·m (kgf·m, ft·lb)

T1: 7.5 (0.76, 5.5)

T2: 35 (3.6, 26)

T3: 50 (5.1, 37)

T4: 58 (5.9, 43)

T5: 70 (7.1, 51.6)

T6: 140 (14.3, 103)

C: CAUTION

- Wear appropriate work clothing, including a cap, protective goggles and protective shoes when performing any work.
- Remove contamination including dirt and corrosion before removal, installation or disassembly.
- Keep the disassembled parts in order and protect them from dust and dirt.
- Before removal, installation or disassembly, be sure to clarify the abnormal condition. Avoid unnecessary removal, installation, disassembly and replacement.
- When disassembling the case and other light alloy parts, use a plastic hammer to force it apart. Do not pry apart with screwdrivers or other tools.
- Vehicle components are extremely hot after driving. Be wary of receiving burns from heated parts.
- Use SUBARU genuine gear oil, grease etc. or equivalent. Do not mix fluid, grease, etc. of different grades or manufacturers.
- Be sure to tighten fasteners including bolts and nuts to the specified torque.
- Place shop jacks or rigid racks at the specified points.
- Apply gear oil onto sliding or revolving surfaces before installation.
- Replace deformed or damaged snap rings with new parts.
- Before installing O-rings or oil seals, apply sufficient amount of gear oil to avoid damage and deformation.
- Be careful not to incorrectly install or fail to install O-rings, snap rings and other such parts.
- Before securing a part on a vise, place cushioning material such as wood blocks, aluminum plate, or cloth between the part and the vise.
- Avoid damaging the mating surface of the case.
- Before applying liquid gasket, completely remove the liquid gasket.

General Description

MANUAL TRANSMISSION AND DIFFERENTIAL

D: PREPARATION TOOL

1. SPECIAL TOOL

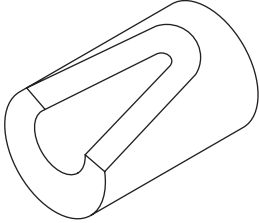
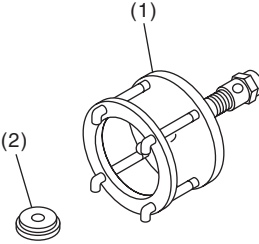
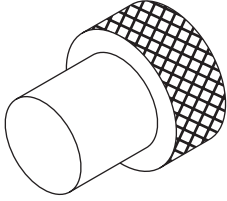
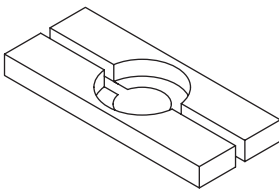
ILLUSTRATION	TOOL NUMBER	DESCRIPTION	REMARKS
 <p style="text-align: center;">ST-399411700</p>	399411700	ACCENT BALL INSTALLER	Used for installing reverse shifter rail arm.
 <p style="text-align: center;">ST-899524100</p>	899524100	PULLER SET	Used for removing and installing the roller bearing (Differential). (1) Puller (2) Cap
 <p style="text-align: center;">ST-399780104</p>	399780104	WEIGHT	Used for measuring preload on the roller bearing.
 <p style="text-align: center;">ST-498077000</p>	498077000	REMOVER	Used for removing the roller bearing of the drive pinion shaft.

General Description

MANUAL TRANSMISSION AND DIFFERENTIAL

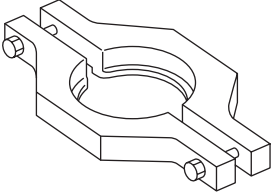
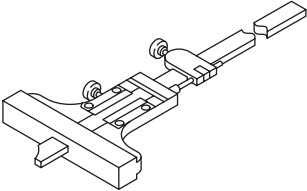
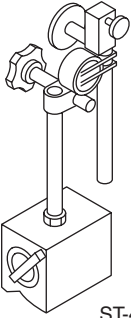
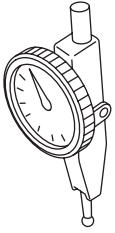
ILLUSTRATION	TOOL NUMBER	DESCRIPTION	REMARKS
 <p data-bbox="337 520 467 541">ST-498077300</p>	498077300	CENTER DIFFERENTIAL BEARING REMOVER	Used for removing the center differential cover ball bearing.
 <p data-bbox="337 888 467 909">ST-498147000</p>	498147000	DEPTH GAUGE	Used for adjusting the main shaft axial end play.
 <p data-bbox="337 1255 467 1276">ST-498247001</p>	498247001	MAGNET BASE	<ul style="list-style-type: none"> • Used for measuring backlash between the side gear and pinion, and the hypoid gear. • Used together with the DIAL GAUGE (498247100).
 <p data-bbox="337 1617 467 1638">ST-498247100</p>	498247100	DIAL GAUGE	<ul style="list-style-type: none"> • Used for measuring backlash between the side gear and pinion, and the hypoid gear. • Used together with the MAGNET BASE (498247001).

General Description

MANUAL TRANSMISSION AND DIFFERENTIAL

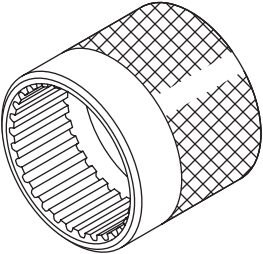
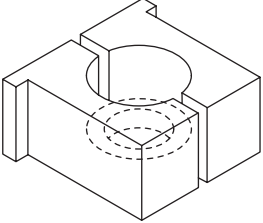
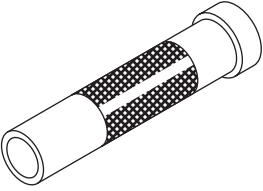
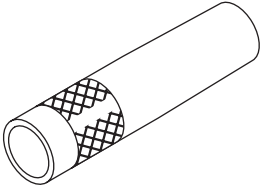
ILLUSTRATION	TOOL NUMBER	DESCRIPTION	REMARKS
 <p style="text-align: center;">ST-498427100</p>	498427100	STOPPER	Used for securing the drive pinion shaft assembly and the driven gear assembly when removing the drive pinion shaft assembly lock nut.
 <p style="text-align: center;">ST-498937000</p>	498937000	TRANSMISSION HOLDER	Used for removing and installing the lock nut of the transmission main shaft.
 <p style="text-align: center;">ST-499277100</p>	499277100	BUSHING 1-2 INSTALLER	<ul style="list-style-type: none"> • Used for installing the 1st driven gear thrust plate and the 1st-2nd driven gear bushing. • Used for installing the roller bearing outer race to the differential case.
 <p style="text-align: center;">ST-499277200</p>	499277200	INSTALLER	Used for press-fitting the 2nd driven gear, roller bearings and the 5th driven gear onto the driven shaft.

General Description

MANUAL TRANSMISSION AND DIFFERENTIAL

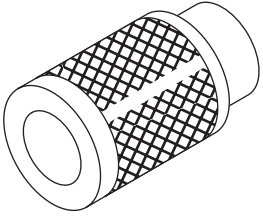
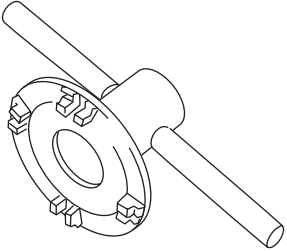
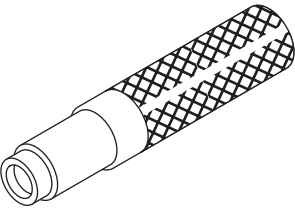
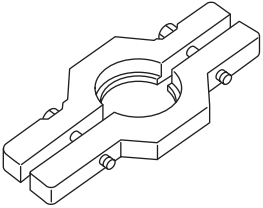
ILLUSTRATION	TOOL NUMBER	DESCRIPTION	REMARKS
 <p data-bbox="337 520 467 541">ST-499757002</p>	499757002	INSTALLER	<ul style="list-style-type: none"> • Used for installing the snap ring (OUT 25), and ball bearing (25 × 26 × 17). • Used for installing the bearing cone of the transfer driven gear (extension core side).
 <p data-bbox="326 884 467 905">ST18630AA010</p>	18630AA010	WRENCH COMPL RETAINER	<ul style="list-style-type: none"> • Used for removing and installing the differential side retainer. • WRENCH ASSEMBLY (499787000) can also be used.
 <p data-bbox="337 1251 467 1272">ST-499827000</p>	499827000	PRESS	Used for installing the speedometer oil seal when attaching the speedometer cable to the transmission.
 <p data-bbox="337 1619 467 1640">ST-499857000</p>	499857000	5TH DRIVEN GEAR REMOVER	Used for removing the 5th driven gear.

General Description

MANUAL TRANSMISSION AND DIFFERENTIAL

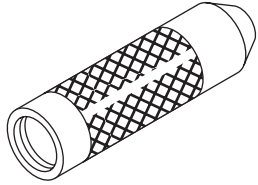
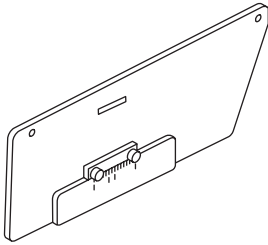
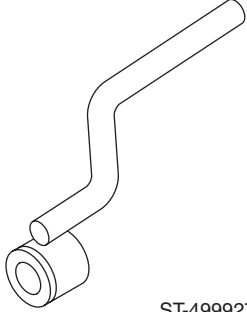
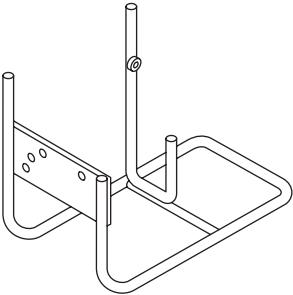
ILLUSTRATION	TOOL NUMBER	DESCRIPTION	REMARKS
 <p style="text-align: center;">ST-499877000</p>	499877000	RACE 4-5 INSTALLER	<ul style="list-style-type: none"> • Used for installing the 4th needle bearing race and ball bearing onto the transmission main shaft. • Used together with the REMOVER (899714110).
 <p style="text-align: center;">ST-499917500</p>	499917500	DRIVE PINION GAUGE ASSY	Used for adjusting the drive pinion shim.
 <p style="text-align: center;">ST-499927100</p>	499927100	HANDLE	Used for fitting the transmission main shaft.
 <p style="text-align: center;">ST-499937100</p>	499937100	TRANSMISSION STAND	Stand used for disassembling and assembling the transmission.

General Description

MANUAL TRANSMISSION AND DIFFERENTIAL

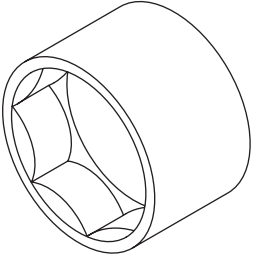
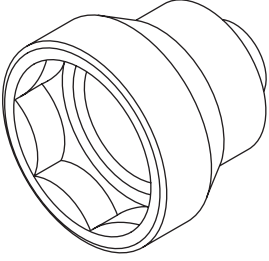
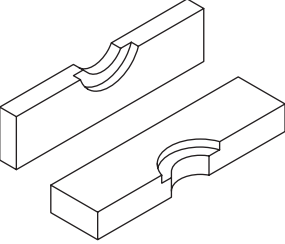
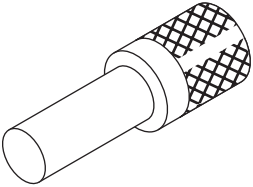
ILLUSTRATION	TOOL NUMBER	DESCRIPTION	REMARKS
 <p data-bbox="337 520 467 541">ST-499987003</p>	499987003	SOCKET WRENCH (35)	Used for removing and installing the driven pinion lock nut and main shaft lock nut.
 <p data-bbox="337 888 467 909">ST-499987300</p>	499987300	SOCKET WRENCH (50)	Used for removing and installing the driven gear assembly lock nut.
 <p data-bbox="337 1255 467 1276">ST-899714110</p>	899714110	REMOVER	Used for fixing the transmission main shaft, drive pinion and rear drive shaft.
 <p data-bbox="337 1619 467 1640">ST-899864100</p>	899864100	REMOVER	Used for removing transmission main shaft and drive pinion parts.

General Description

MANUAL TRANSMISSION AND DIFFERENTIAL

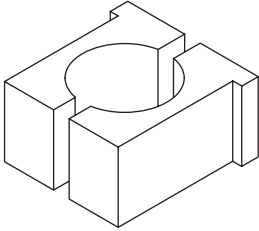
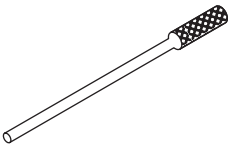
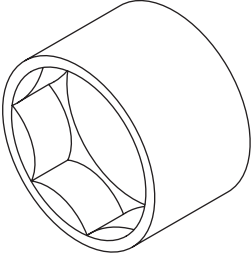
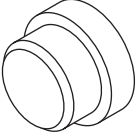
ILLUSTRATION	TOOL NUMBER	DESCRIPTION	REMARKS
 <p style="text-align: center;">ST-899884100</p>	899884100	HOLDER	Used for tightening the lock nut on the sleeve.
 <p style="text-align: center;">ST-899904100</p>	899904100	STRAIGHT PIN REMOVER	Used for removing and installing the straight pin.
 <p style="text-align: center;">ST-899988608</p>	899988608	SOCKET WRENCH (27)	Used for removing and installing the drive pinion lock nut.
 <p style="text-align: center;">ST-398497701</p>	398497701	ADAPTER	<ul style="list-style-type: none"> • Used for installing roller bearing onto the differential case. • Used together with the BUSHING 1-2 INSTALLER (499277100).

General Description

MANUAL TRANSMISSION AND DIFFERENTIAL

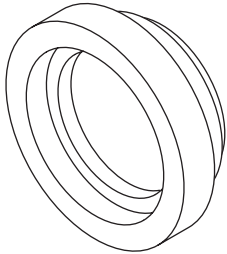
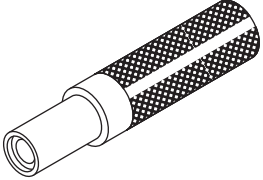
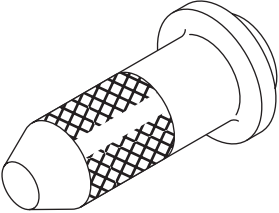
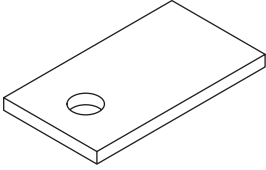
ILLUSTRATION	TOOL NUMBER	DESCRIPTION	REMARKS
 <p data-bbox="337 516 467 541">ST-499587000</p>	499587000	INSTALLER	Used for installing the driven gears to the driven shaft.
 <p data-bbox="337 884 467 909">ST-899824100</p>	899824100	PRESS	Used for installing the speedometer shaft oil seal.
 <p data-bbox="337 1251 467 1276">ST-498057300</p>	498057300	INSTALLER	Used for installing the extension oil seal.
 <p data-bbox="337 1619 467 1644">ST-498255400</p>	498255400	PLATE	Used for measuring backlash.

General Description

MANUAL TRANSMISSION AND DIFFERENTIAL

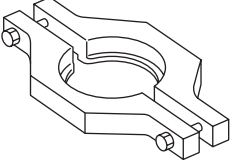
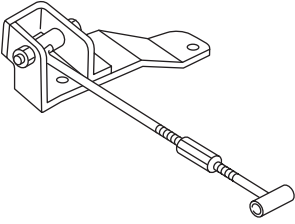
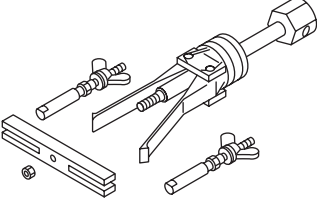
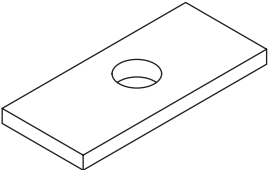
ILLUSTRATION	TOOL NUMBER	DESCRIPTION	REMARKS
 <p style="text-align: center;">ST-498077400</p>	<p style="text-align: center;">498077400</p>	<p>SYNCHRO CONE REMOVER</p>	<ul style="list-style-type: none"> • Used for removing the synchronizer cone of the main shaft. • Used for removing 5th driven gear of the drive pinion shaft.
 <p style="text-align: center;">ST41099AC000</p>	<p style="text-align: center;">41099AC000</p>	<p>ENGINE SUPPORT BRACKET</p>	<p>Used for supporting the engine.</p>
 <p style="text-align: center;">ST-398527700</p>	<p style="text-align: center;">398527700</p>	<p>PULLER ASSY</p>	<p>Used for removing the extension case roller bearing.</p>
 <p style="text-align: center;">ST-398643600</p>	<p style="text-align: center;">398643600</p>	<p>GAUGE</p>	<p>Used for measuring the total end play, extension end play and drive pinion height.</p>

General Description

MANUAL TRANSMISSION AND DIFFERENTIAL

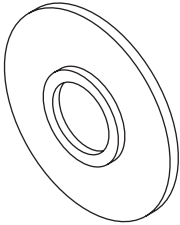
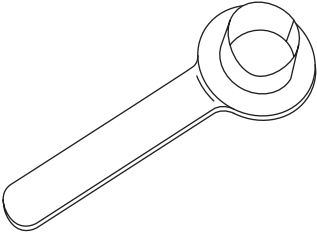
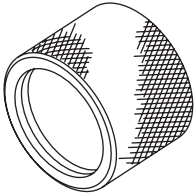
ILLUSTRATION	TOOL NUMBER	DESCRIPTION	REMARKS
 <p>ST-398177700</p>	398177700	INSTALLER	<ul style="list-style-type: none"> Used for installing the bearing cone of transfer driven gear (transfer case side). Used for installing the ball bearing of the transfer drive gear.
 <p>ST28399SA010</p>	28399SA010	OIL SEAL PROTECTOR	Used for protecting the oil seal from damage when inserting the front drive shaft.
 <p>ST18675AA000</p>	18675AA000	DIFFERENTIAL SIDE OIL SEAL INSTALLER	Used for installing the differential side retainer oil seal.

2. GENERAL TOOL

TOOL NAME	REMARKS
Circuit tester	Used for measuring resistance, voltage and current.
TORX® bit T70	Used for installing and removing the transmission gear oil drain plug.

Transmission Gear Oil

MANUAL TRANSMISSION AND DIFFERENTIAL

2. Transmission Gear Oil

A: INSPECTION

- 1) Park the vehicle on a level surface.
- 2) Turn the ignition switch to OFF, and wait until the engine cools.
- 3) Remove the oil level gauge and wipe it clean.
- 4) Reinsert the level gauge all the way. Be sure that the level gauge is correctly inserted in the proper direction.
- 5) Pull out the oil level gauge again, and check the oil level. If it is lower level or less, add oil through the oil level gauge hole to bring the level up to the upper level.

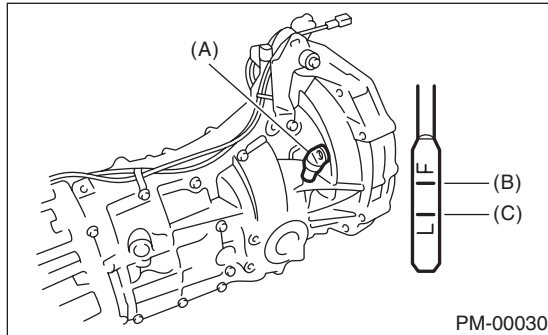

- (A) Oil level gauge
- (B) Upper level
- (C) Lower level

B: REPLACEMENT

- 1) Pull out the oil level gauge.
- 2) Lift up the vehicle.
- 3) Using the TORX® bit T70, remove the drain plug, and drain the transmission gear oil completely.

CAUTION:

- Immediately after the engine has been running, the transmission gear oil is hot. Be careful not to burn yourself.
- Be careful not to spill the transmission gear oil on the exhaust pipe, to prevent emission of smoke or causing a fire. If differential gear oil is spilled on the exhaust pipe, wipe it off completely.

- 4) Using the TORX® bit T70, tighten the transmission gear oil drain plug.

NOTE:

- Tighten the drain plug of the transmission gear oil after draining the transmission gear oil.
- Use a new gasket.

Tightening torque:

44 N·m (4.5 kgf-m, 32.5 ft-lb) (Aluminum gasket)

70 N·m (7.1 kgf-m, 51.6 ft-lb) (Copper gasket)

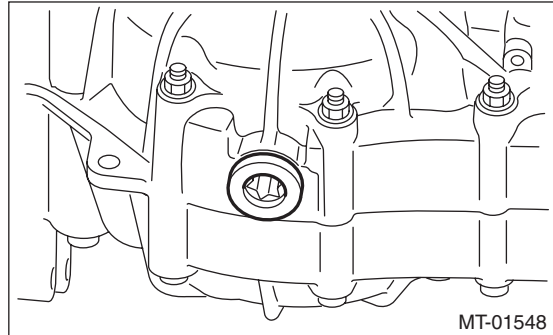

- 5) Lower the vehicle.
- 6) Pour gear oil through the gauge hole.

Recommended gear oil:

GL-5 (75W-90) or equivalent

Gear oil capacity:

3.5 ℓ (3.7 US qt, 3.1 Imp qt)

- 7) Measure the transmission gear oil level to check that it is within specifications.

CAUTION:

When inserting the level gauge into transmission, align the protrusion on the top part of the level gauge with the notch in the gauge hole.

3. Manual Transmission Assembly

A: REMOVAL

- 1) Set the vehicle on a lift.
- 2) Open the front hood fully, and support with stay.
- 3) Disconnect the ground cable from battery.
- 4) Remove the air intake duct and air cleaner case. (Non-turbo model) <Ref. to IN(H4SO)-7, REMOVAL, Air Intake Duct.> <Ref. to IN(H4SO)-5, REMOVAL, Air Cleaner Case.>
- 5) Remove the air cleaner case stay. (Non-turbo model)

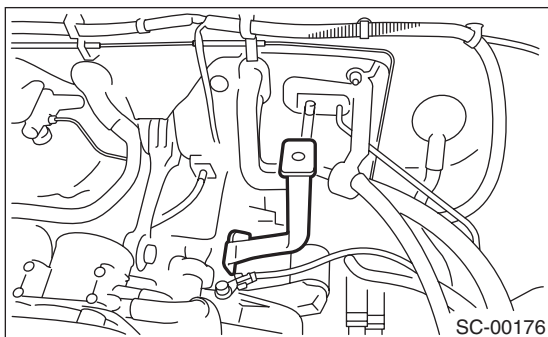

- 6) Remove the intercooler. (Turbo model) <Ref. to IN(H4DOTC)-13, REMOVAL, Intercooler.>

- 7) Disconnect the connectors listed below.

- (1) Neutral position switch connector
- (2) Back-up light switch connector
- (3) Vehicle Speed Sensor

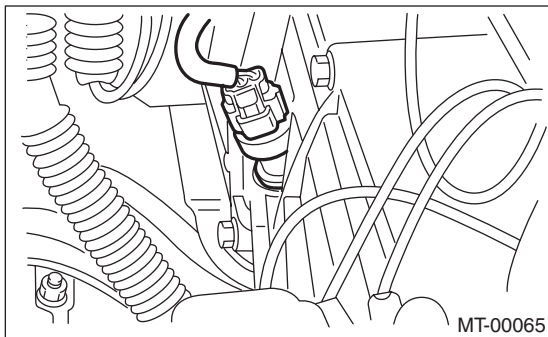

- 8) Remove the starter. <Ref. to SC(H4SO)-8, REMOVAL, Starter.>

- 9) Remove the operating cylinder from the transmission, and suspend on a wire.

- Non-turbo model

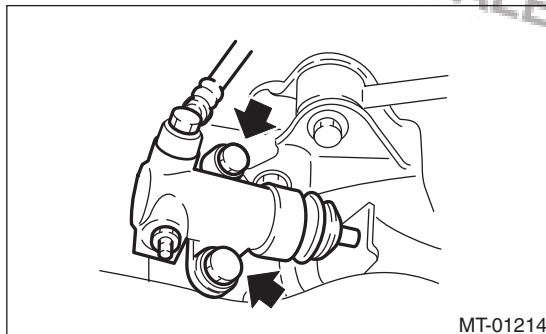

- Turbo model

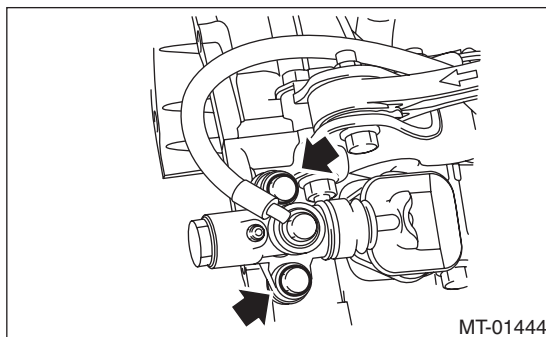

- 10) Remove the throttle body.

- Non-turbo model

<Ref. to FU(H4SO)-12, REMOVAL, Throttle Body.>

- Turbo model

<Ref. to FU(H4DOTC)-16, REMOVAL, Throttle Body.>

- 11) Remove the pitching stopper.

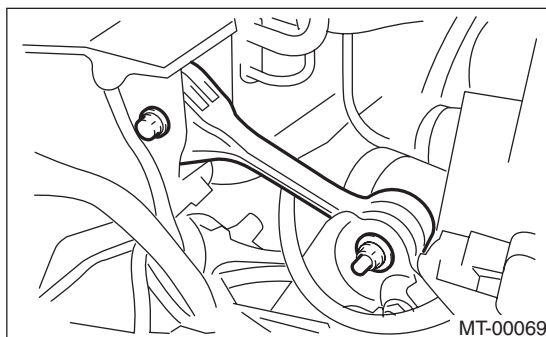

- 12) Set the ST.

ST 41099AC000 ENGINE SUPPORT BRACKET

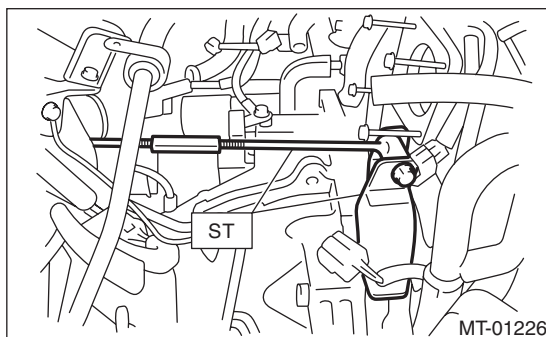

Manual Transmission Assembly

MANUAL TRANSMISSION AND DIFFERENTIAL

13) Remove the bolts which hold upper side of transmission to engine.

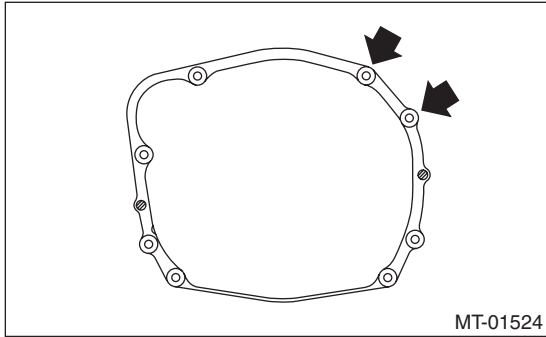

14) Remove the front and center exhaust pipes. (Non-turbo model) <Ref. to EX(H4SO)-4, REMOVAL, Front Exhaust Pipe.> <Ref. to EX(H4SO)-7, REMOVAL, Center Exhaust Pipe.>

15) Remove the center exhaust pipe. (Turbo model) <Ref. to EX(H4DOTC)-10, REMOVAL, Center Exhaust Pipe.>

16) Remove the rear exhaust pipe and muffler.

- Non-turbo model

<Ref. to EX(H4SO)-8, REMOVAL, Rear Exhaust Pipe.> <Ref. to EX(H4SO)-9, REMOVAL, Muffler.>

- Turbo model

<Ref. to EX(H4DOTC)-15, REMOVAL, Rear Exhaust Pipe.> <Ref. to EX(H4DOTC)-17, REMOVAL, Muffler.>

CAUTION:

When removing the exhaust pipes, be careful each exhaust pipe does not drop out.

17) Remove the hanger bracket from the right side of transmission.

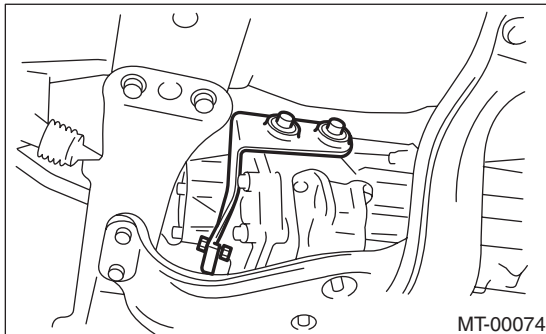

18) Remove the propeller shaft. <Ref. to DS-15, REMOVAL, Propeller Shaft.>

19) Remove the gear shift rod and the stay from the transmission.

(1) Disconnect the stay from the transmission.

(2) Disconnect the gear shift rod from the transmission.

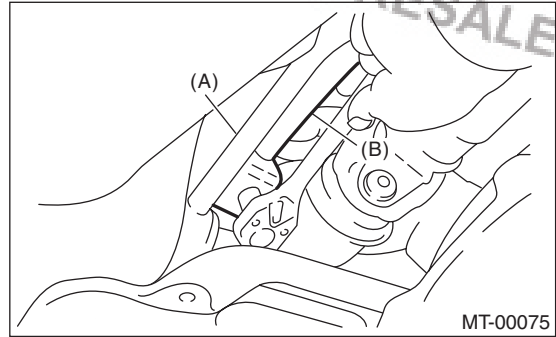

(A) Stay

(B) Gear shift rod

20) Separate the stabilizer link from the transverse link.

- Wagon model

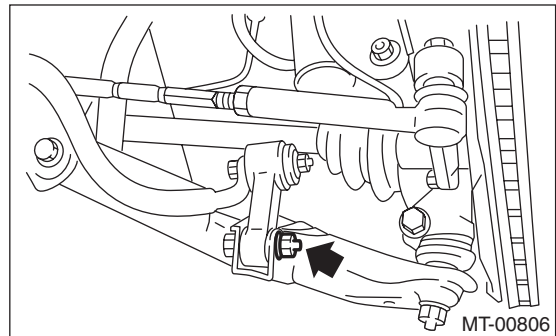

- Sedan model

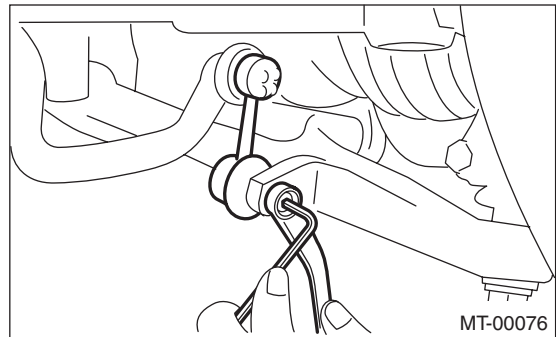

Manual Transmission Assembly

MANUAL TRANSMISSION AND DIFFERENTIAL

21) Remove the bolt securing the ball joint of the transverse link to the housing, then separate the transverse link and the housing.

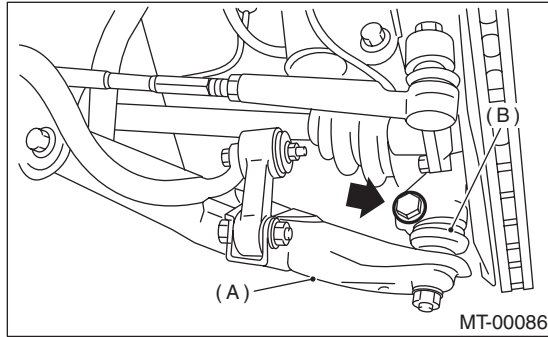

- (A) Transverse link
- (B) Ball joint

22) Using a crowbar, remove the left and right front drive shaft from the transmission.

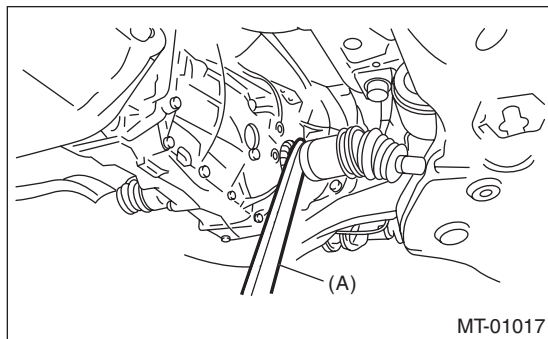

- (A) Crowbar

23) Remove the nuts which hold lower side of transmission to engine.

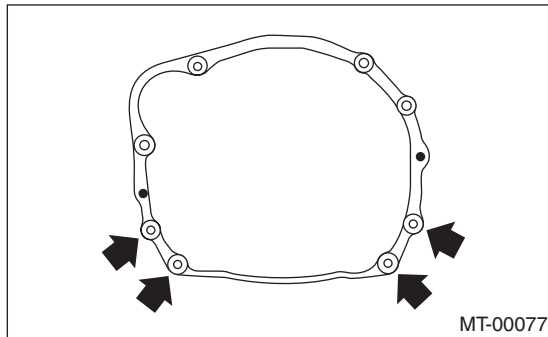

24) Place the transmission jack under the transmission.

CAUTION:

Always support the transmission case with a transmission jack.

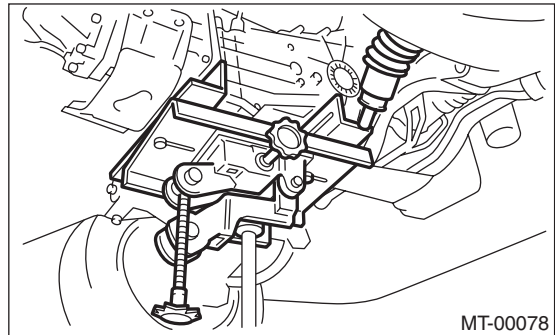

25) Remove the front crossmember and rear crossmember from the vehicle.

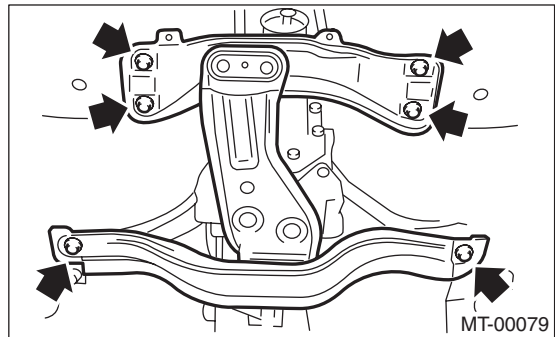

26) Tighten the turnbuckle of the ST while lowering the transmission jack to tilt the engine assembly towards the back.

27) Remove the transmission.

NOTE:

Move the transmission jack towards the rear until the main shaft is withdrawn from the clutch disc.

28) Separate the transmission assembly from the transmission cushion rubber.

Manual Transmission Assembly

MANUAL TRANSMISSION AND DIFFERENTIAL

B: INSTALLATION

1) Replace the differential side retainer oil seal.
<Ref. to 5MT-34, REPLACEMENT, Differential Side Retainer Oil Seal.>

ST 18675AA000 DIFFERENTIAL SIDE OIL SEAL INSTALLER

NOTE:

Be sure to replace the differential side retainer oil seal after the removing the front drive shaft.

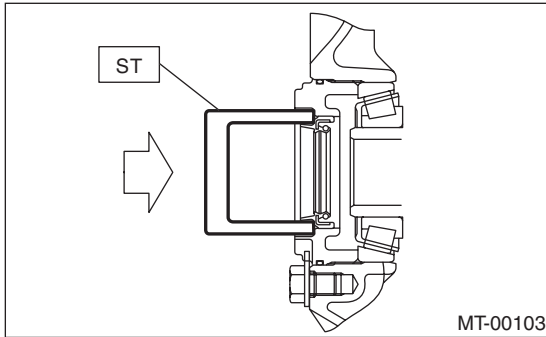

2) Install the transmission cushion rubber to the transmission assembly.

Tightening torque:

35 N·m (3.6 kgf-m, 26 ft-lb)

3) Install the transmission onto the engine.

- (1) Lift up the transmission gradually using a transmission jack.
- (2) Engage at the spline section.

NOTE:

Be careful not to hit the main shaft against the clutch cover.

4) Loosen the turnbuckle of the ST while raising the transmission jack to return the engine to its original position.

5) Install the front crossmember and rear crossmember.

Tightening torque:

T1: 70 N·m (7.1 kgf-m, 51.6 ft-lb)

T2: 140 N·m (14.3 kgf-m, 103 ft-lb)

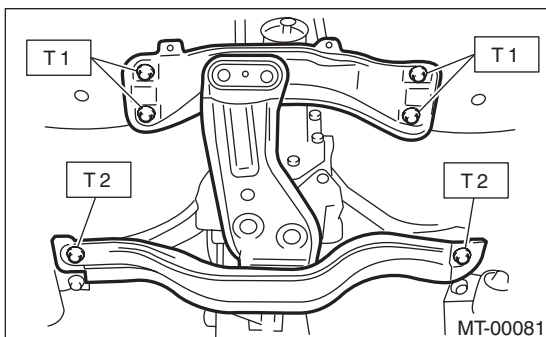

6) Take out the transmission jack.

7) Tighten the nuts which hold the lower side of transmission to the engine.

Tightening torque:

50 N·m (5.1 kgf-m, 37 ft-lb)

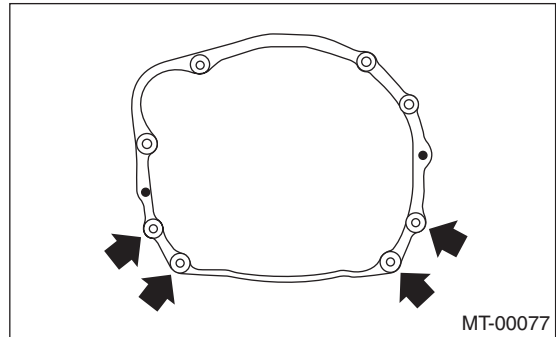

8) Connect the transmission to the engine.

(1) Install the starter.

<Ref. to SC(H4SO)-8, INSTALLATION, Starter.>

(2) Tighten the bolts which hold the upper side of the transmission to the engine.

Tightening torque:

50 N·m (5.1 kgf-m, 37 ft-lb)

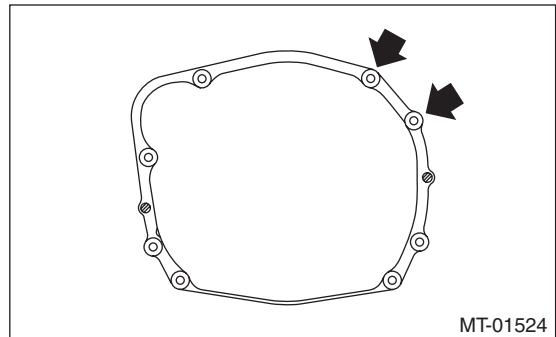

9) Remove the ST.

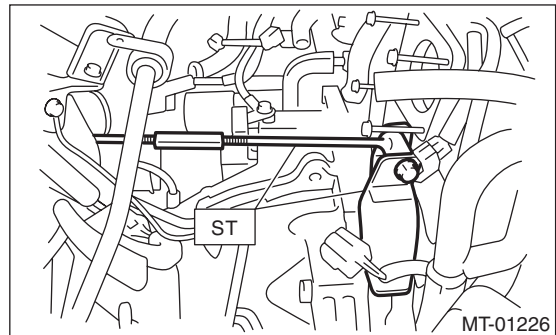

Manual Transmission Assembly

MANUAL TRANSMISSION AND DIFFERENTIAL

10) Install the pitching stopper.

Tightening torque:

T1: 50 N·m (5.1 kgf·m, 37 ft·lb)

T2: 58 N·m (5.9 kgf·m, 43 ft·lb)

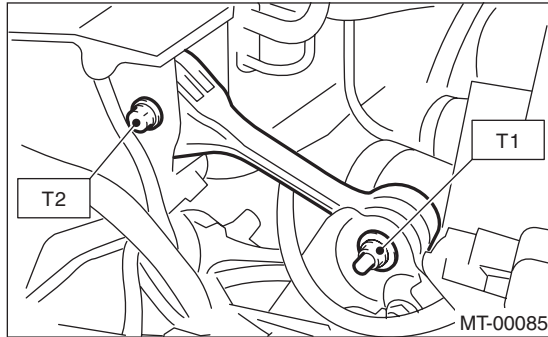

11) Install the throttle body.

- Non-turbo model

<Ref. to FU(H4SO)-12, INSTALLATION, Throttle Body.>

- Turbo model

<Ref. to FU(H4DOTC)-16, INSTALLATION, Throttle Body.>

12) Lift up the vehicle.

13) Install the front drive shaft into the transmission.

ST 28399SA010 OIL SEAL PROTECTOR

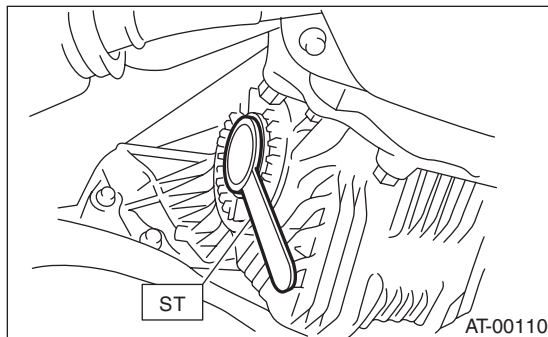

14) Insert the ball joints of the transverse link into the lower part of housing, then tighten the installing bolts.

Tightening torque:

50 N·m (5.1 kgf·m, 36.9 ft·lb)

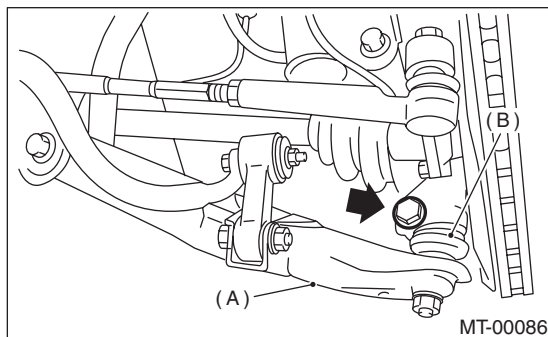

- (A) Transverse link
- (B) Ball joint

15) Attach the stabilizer link to the transverse link.

- Wagon model

Tightening torque:

30 N·m (3.1 kgf·m, 22 ft·lb)

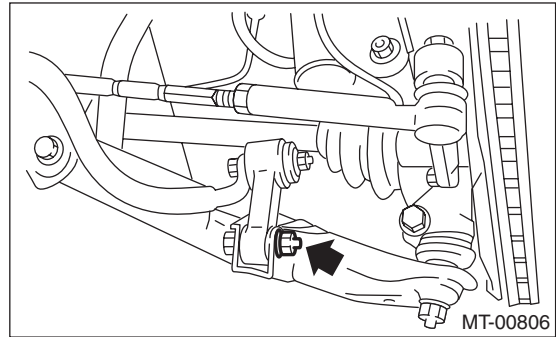

- Sedan model

Tightening torque:

45 N·m (4.6 kgf·m, 33 ft·lb)

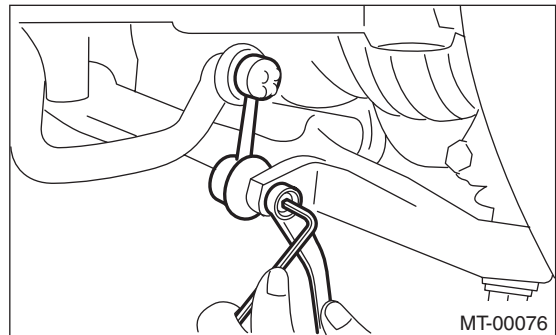

16) Attach the gear shift rod and stay.

- (1) Attach the gear shift rod to the transmission.

Tightening torque:

12 N·m (1.2 kgf·m, 8.9 ft·lb)

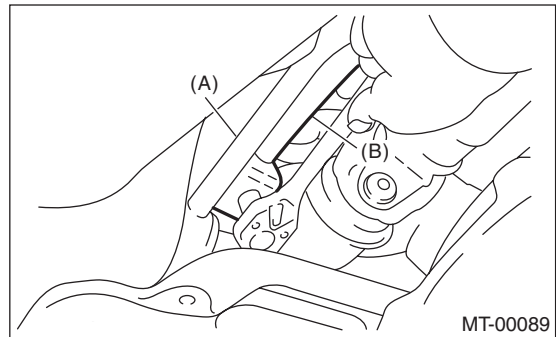

- (A) Stay
- (B) Gear shift rod

- (2) Attach the stay to the transmission.

Tightening torque:

18 N·m (1.8 kgf·m, 13.0 ft·lb)

17) Install the propeller shaft. <Ref. to DS-16, INSTALLATION, Propeller Shaft.>

Manual Transmission Assembly

MANUAL TRANSMISSION AND DIFFERENTIAL

18) Install the hanger bracket on the right side of the transmission.

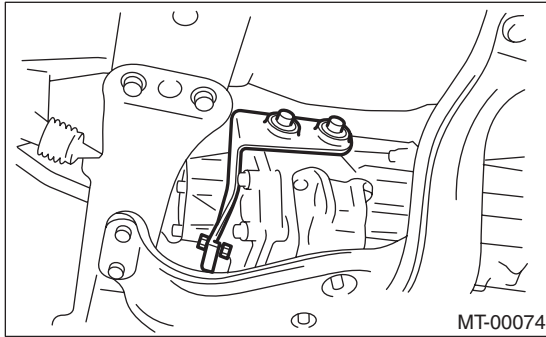

19) Install the rear exhaust pipe and muffler.

- Non-turbo model

<Ref. to EX(H4SO)-8, INSTALLATION, Rear Exhaust Pipe.> <Ref. to EX(H4SO)-9, INSTALLATION, Muffler.>

- Turbo model

<Ref. to EX(H4DOTC)-15, INSTALLATION, Rear Exhaust Pipe.> <Ref. to EX(H4DOTC)-17, INSTALLATION, Muffler.>

20) Install the front exhaust pipe and the center exhaust pipe. (Non-turbo model)

<Ref. to EX(H4SO)-5, INSTALLATION, Front Exhaust Pipe.> <Ref. to EX(H4SO)-7, INSTALLATION, Center Exhaust Pipe.>

21) Install the center exhaust pipe. (Turbo model)
<Ref. to EX(H4DOTC)-11, INSTALLATION, Center Exhaust Pipe.>

22) Install the under cover.

23) Install the operating cylinder.

Tightening torque:

37 N·m (3.8 kgf-m, 27.5 ft-lb)

- Non-turbo model

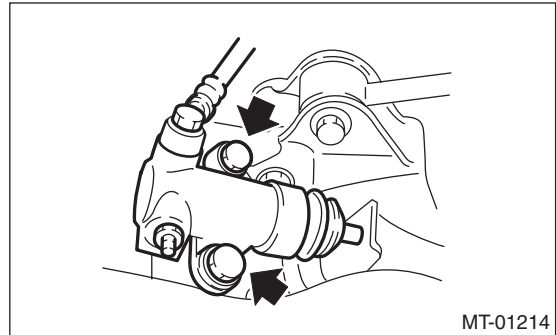

- Turbo model

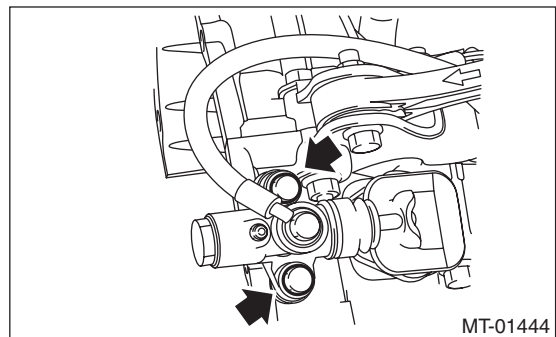

24) Connect the following connectors.

- (1) Transmission ground cable

Tightening torque:

13 N·m (1.3 kgf-m, 9.4 ft-lb)

- (2) Vehicle speed sensor connector
- (3) Neutral position switch connector
- (4) Back-up light switch connector

25) Install the air cleaner case stay.

Tightening torque:

16 N·m (1.6 kgf-m, 11.6 ft-lb)

26) Install the air intake duct and air cleaner case. (Non-turbo model)

<Ref. to IN(H4SO)-5, INSTALLATION, Air Cleaner Case.>, <Ref. to IN(H4SO)-7, INSTALLATION, Air Intake Duct.>

27) Install the intercooler. (Turbo model)

<Ref. to IN(H4DOTC)-14, INSTALLATION, Intercooler.>

28) Connect the ground cable to battery.

29) Take off the vehicle from lift arms.

4. Transmission Mounting System

A: REMOVAL

1. PITCHING STOPPER

- 1) Disconnect the ground cable from battery.
- 2) Remove the air intake duct and air cleaner case. (Non-turbo model) <Ref. to IN(H4SO)-7, REMOVAL, Air Intake Duct.> and <Ref. to IN(H4SO)-5, REMOVAL, Air Cleaner Case.>
- 3) Remove the intercooler. (Turbo model) <Ref. to IN(H4DOTC)-13, REMOVAL, Intercooler.>
- 4) Remove the throttle body.
 - Non-turbo model
<Ref. to FU(H4SO)-12, REMOVAL, Throttle Body.>
 - Turbo model
<Ref. to FU(H4DOTC)-16, REMOVAL, Throttle Body.>
- 5) Remove the pitching stopper.

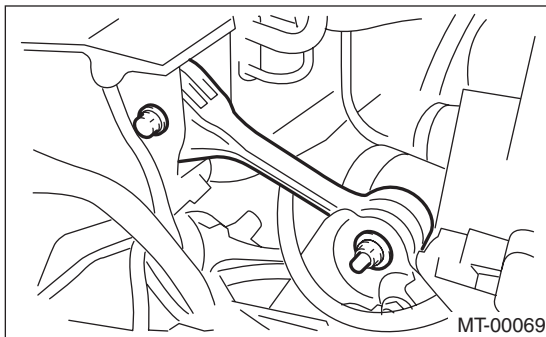

2. CROSSMEMBER AND CUSHION RUBBER

- 1) Disconnect the ground cable from battery.
- 2) Lift up the vehicle.
- 3) Remove the front and center exhaust pipes. (Non-turbo model)
<Ref. to EX(H4SO)-4, REMOVAL, Front Exhaust Pipe.> <Ref. to EX(H4SO)-7, REMOVAL, Center Exhaust Pipe.>
- 4) Remove the center exhaust pipe. (Turbo model)
<Ref. to EX(H4DOTC)-10, REMOVAL, Center Exhaust Pipe.>
- 5) Remove the rear exhaust pipe and muffler.
 - Non-turbo model
<Ref. to EX(H4SO)-8, REMOVAL, Rear Exhaust Pipe.> <Ref. to EX(H4SO)-9, REMOVAL, Muffler.>
 - Turbo model
<Ref. to EX(H4DOTC)-15, REMOVAL, Rear Exhaust Pipe.> <Ref. to EX(H4DOTC)-17, REMOVAL, Muffler.>

- 6) Set the transmission jack under the transmission body.

CAUTION:

Always support the transmission case with a transmission jack.

- 7) Remove the front crossmember and rear crossmember.

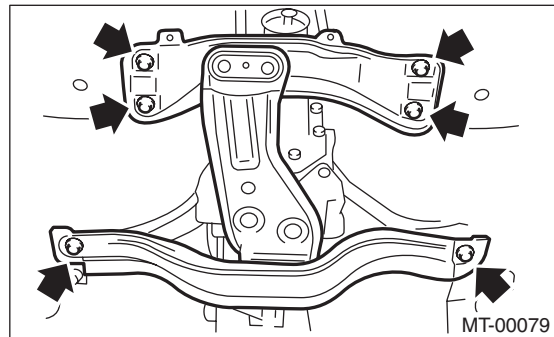

- 8) Remove the transmission cushion rubber.

B: INSTALLATION

1. PITCHING STOPPER

- 1) Install the pitching stopper.

Tightening torque:

T1: 50 N·m (5.1 kgf·m, 37 ft·lb)

T2: 58 N·m (5.9 kgf·m, 43 ft·lb)

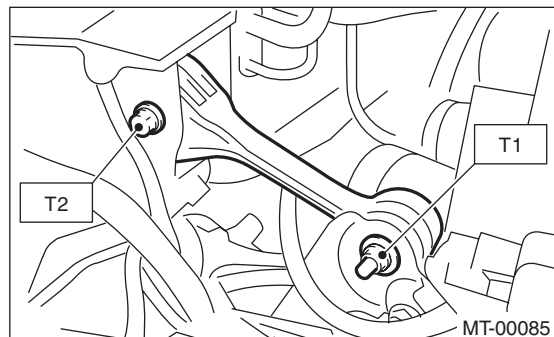

- 2) Install the throttle body.
 - Non-turbo model
<Ref. to FU(H4SO)-12, INSTALLATION, Throttle Body.>
 - Turbo model
<Ref. to FU(H4DOTC)-16, INSTALLATION, Throttle Body.>
- 3) Install the air intake duct and air cleaner case. (Non-turbo model)
<Ref. to IN(H4SO)-5, INSTALLATION, Air Cleaner Case.> <Ref. to IN(H4SO)-7, INSTALLATION, Air Intake Duct.>
- 4) Install the intercooler. (Turbo model)
<Ref. to IN(H4DOTC)-14, INSTALLATION, Intercooler.>
- 5) Connect the ground cable to battery.

Transmission Mounting System

MANUAL TRANSMISSION AND DIFFERENTIAL

2. CROSSMEMBER AND CUSHION RUBBER

1) Install the transmission cushion rubber.

Tightening torque:

35 N·m (3.6 kgf·m, 26 ft·lb)

2) Install the front crossmember and rear crossmember.

Tightening torque:

T1: 70 N·m (7.1 kgf·m, 51 ft·lb)

T2: 140 N·m (14.3 kgf·m, 103 ft·lb)

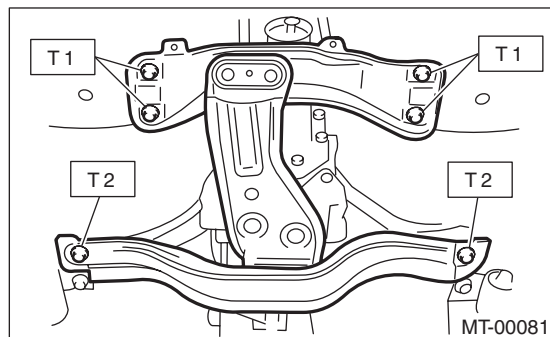

3) Remove the transmission jack.

4) Install the front and center exhaust pipe. (Non-turbo model)

<Ref. to EX(H4SO)-5, INSTALLATION, Front Exhaust Pipe.> <Ref. to EX(H4SO)-7, INSTALLATION, Center Exhaust Pipe.>

5) Install the center exhaust pipe. (Turbo model)
<Ref. to EX(H4DOTC)-11, INSTALLATION, Center Exhaust Pipe.>

6) Install the rear exhaust pipe and muffler.

- Non-turbo model

<Ref. to EX(H4SO)-8, INSTALLATION, Rear Exhaust Pipe.> <Ref. to EX(H4SO)-9, INSTALLATION, Muffler.>

- Turbo model

<Ref. to EX(H4DOTC)-15, INSTALLATION, Rear Exhaust Pipe.> <Ref. to EX(H4DOTC)-17, INSTALLATION, Muffler.>

C: INSPECTION

Perform the following inspection procedures, and repair or replace faulty parts.

1. PITCHING STOPPER

Make sure that the pitching stopper is not bent or damaged. Check that the rubber is not stiff, cracked or otherwise damaged.

2. CROSSMEMBER AND CUSHION RUBBER

Make sure that the crossmember is not bent or damaged. Check that the rubber is not stiff, cracked or otherwise damaged.

5. Oil Seal

A: INSPECTION

Check the oil seals for leaks. If there is leakage, replace the oil seal and check the propeller shaft.

B: REPLACEMENT

- 1) Clean the transmission exterior.
- 2) Using the TORX® bit T70, remove the drain plug, and drain the transmission gear oil completely.
- 3) Using the TORX® bit T70, tighten the transmission gear oil drain plug.

NOTE:

Use a new gasket.

Tightening torque:

44 N·m (4.5 kgf·m, 32.5 ft·lb) (Aluminum gasket)

70 N·m (7.1 kgf·m, 51.6 ft·lb) (Copper gasket)

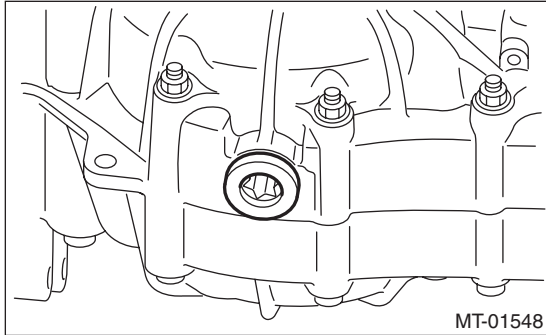

- 4) Remove the rear exhaust pipe and muffler.
 - Non-turbo model
<Ref. to EX(H4SO)-8, REMOVAL, Rear Exhaust Pipe.> <Ref. to EX(H4SO)-9, REMOVAL, Muffler.>
 - Turbo model
<Ref. to EX(H4DOTC)-15, REMOVAL, Rear Exhaust Pipe.> <Ref. to EX(H4DOTC)-17, REMOVAL, Muffler.>
 - 5) Remove the propeller shaft. <Ref. to DS-15, REMOVAL, Propeller Shaft.>
 - 6) Remove the oil seal using ST.
- ST 398527700 PULLER ASSY

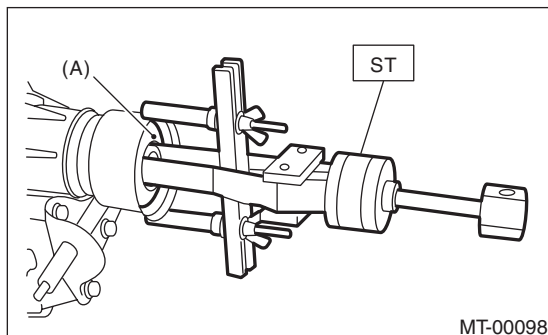

(A) Oil seal

- 7) Using the ST, install the oil seal.
- ST 498057300 INSTALLER

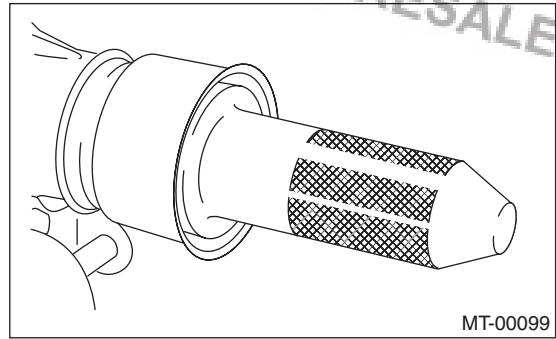

- 8) Install the propeller shaft. <Ref. to DS-16, INSTALLATION, Propeller Shaft.>
- 9) Install the rear exhaust pipe and muffler.
 - Non-turbo model
<Ref. to EX(H4SO)-8, INSTALLATION, Rear Exhaust Pipe.> <Ref. to EX(H4SO)-9, INSTALLATION, Muffler.>
 - Turbo model
<Ref. to EX(H4DOTC)-15, INSTALLATION, Rear Exhaust Pipe.> <Ref. to EX(H4DOTC)-17, INSTALLATION, Muffler.>
- 10) Pour in gear oil and check the oil level. <Ref. to 5MT-24, REPLACEMENT, Transmission Gear Oil.>

Differential Side Retainer Oil Seal

MANUAL TRANSMISSION AND DIFFERENTIAL

6. Differential Side Retainer Oil Seal

A: INSPECTION

Check for oil leakage from differential side retainer oil seal part. If there is oil leakage, replace with a new oil seal and check the drive shaft.

B: REPLACEMENT

- 1) Lift up the vehicle.
- 2) Remove the differential gear oil drain plug using TORX® bit T70, and drain the differential gear oil completely.

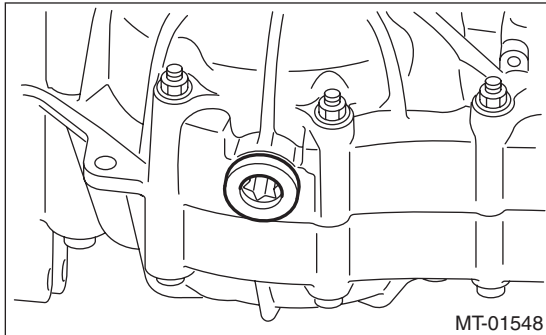

- 3) Replace the gasket with a new part and tighten the differential oil drain plug using the TORX® bit T70.

Tightening torque:

44 N·m (4.5 kgf·m, 32.5 ft·lb) (Aluminum gasket)

70 N·m (7.1 kgf·m, 51.6 ft·lb) (Copper gasket)

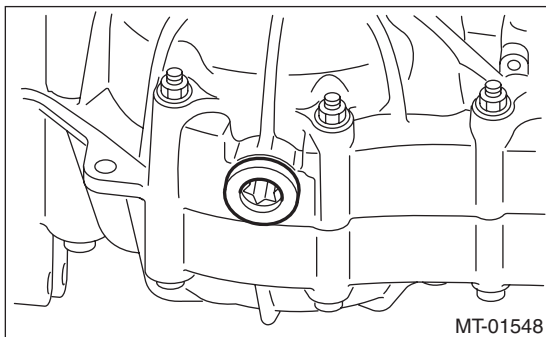

- 4) Remove the front and center exhaust pipes. (Non-turbo model)
<Ref. to EX(H4SO)-4, REMOVAL, Front Exhaust Pipe.> <Ref. to EX(H4SO)-7, REMOVAL, Center Exhaust Pipe.>
- 5) Remove the center exhaust pipe. (Turbo model)
<Ref. to EX(H4DOTC)-10, REMOVAL, Center Exhaust Pipe.>
- 6) Separate the front drive shaft from the transmission. <Ref. to DS-31, REMOVAL, Front Drive Shaft.>

- 7) Remove the differential side retainer oil seal.

NOTE:

- Be sure to replace the differential side retainer oil seal whenever the front drive shaft is removed from the transmission.
- Use the ST 398527700 PULLER ASSY to remove the oil seal. When removing the part by using a flat tip screwdriver, be careful not to scratch the differential side retainer.

- 8) Using the ST, install the differential side retainer oil seal by lightly tapping with a plastic hammer.
ST 18675AA000 DIFFERENTIAL SIDE OIL SEAL INSTALLER

NOTE:

Apply oil to the oil seal lips.

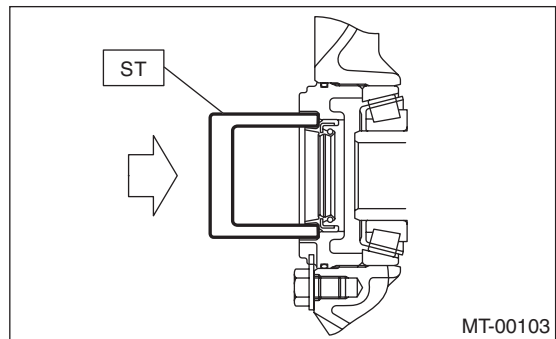

- 9) Install the front drive shaft. <Ref. to DS-31, INSTALLATION, Front Drive Shaft.>
ST 28399SA010 OIL SEAL PROTECTOR
- 10) Install the front and center exhaust pipe. (Non-turbo model)
<Ref. to EX(H4SO)-5, INSTALLATION, Front Exhaust Pipe.> <Ref. to EX(H4SO)-7, INSTALLATION, Center Exhaust Pipe.>
- 11) Install the center exhaust pipe. (Turbo model)
<Ref. to EX(H4DOTC)-11, INSTALLATION, Center Exhaust Pipe.>
- 12) Lower the vehicle.
- 13) Pour gear oil through the oil level gauge hole. <Ref. to 5MT-24, REPLACEMENT, Transmission Gear Oil.>

7. Switches and Harness

A: REMOVAL

1. BACK-UP LIGHT SWITCH AND NEUTRAL POSITION SWITCH

- 1) Disconnect the ground cable from battery.
 - 2) Remove the air intake duct and air cleaner case. (Non-turbo model) <Ref. to IN(H4SO)-5, REMOVAL, Air Cleaner Case.> <Ref. to IN(H4SO)-7, REMOVAL, Air Intake Duct.>
 - 3) Remove the intercooler. (Turbo model) <Ref. to IN(H4DOTC)-13, REMOVAL, Intercooler.>
 - 4) Disconnect the connector back-up light switch and neutral position switch.
- Non-turbo model

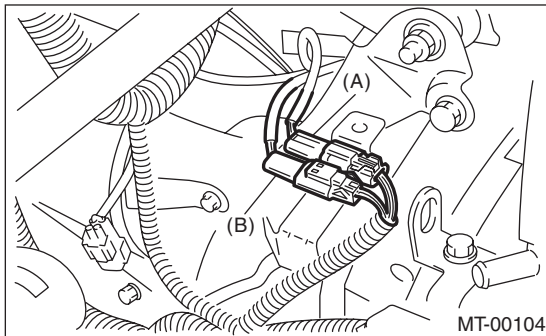

(A) Neutral position switch (Brown)
(B) Back-up light switch (Gray)

- Turbo model

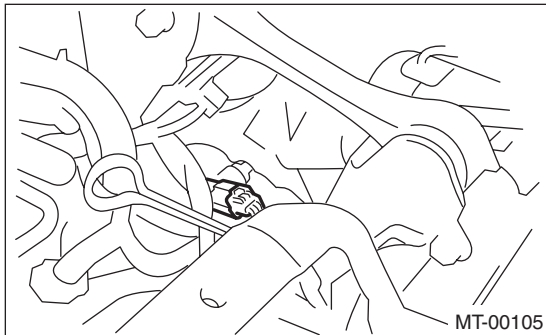

- 5) Lift up the vehicle.

- 6) Remove the back-up light switch and neutral position switch along with the harness.

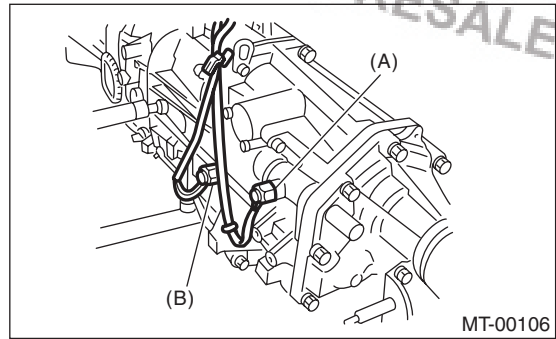

(A) Neutral position switch (Brown)
(B) Back-up light switch (Gray)

B: INSTALLATION

1. BACK-UP LIGHT SWITCH AND NEUTRAL POSITION SWITCH

- 1) Install the back-up light switch and neutral position switch with the harness.

Tightening torque:

32.3 N·m (3.3 kgf-m, 23.8 ft-lb)

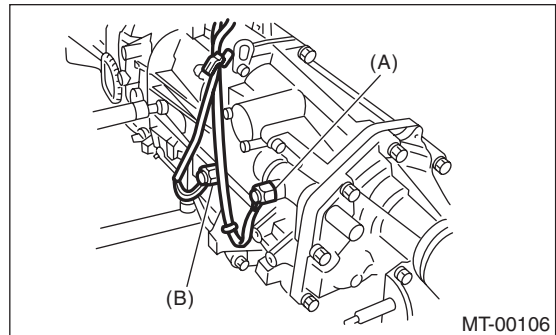

(A) Neutral position switch
(B) Back-up light switch

- 2) Connect the connectors of the back-up light switch and neutral position switch.
- 3) Install the air intake duct and air cleaner case. (Non-turbo model) <Ref. to IN(H4SO)-5, INSTALLATION, Air Cleaner Case.> <Ref. to IN(H4SO)-7, INSTALLATION, Air Intake Duct.>
- 4) Install the intercooler. (Turbo model) <Ref. to IN(H4DOTC)-14, INSTALLATION, Intercooler.>
- 5) Connect the ground cable to battery.

C: INSPECTION

1. BACK-UP LIGHT SWITCH

Check the back-up light switch. <Ref. to LI-9, INSPECTION, Back-up Light System.>

2. NEUTRAL POSITION SWITCH

- 1) Turn the ignition switch to OFF.
- 2) Disconnect the connector of neutral position switch.
- 3) Measure the resistance between neutral position switch terminals.

Non-turbo model:

Gear shift position	Terminal No.	Specified resistance
Neutral position	1 and 2	Less than 1 Ω
Other positions		1 M Ω or more

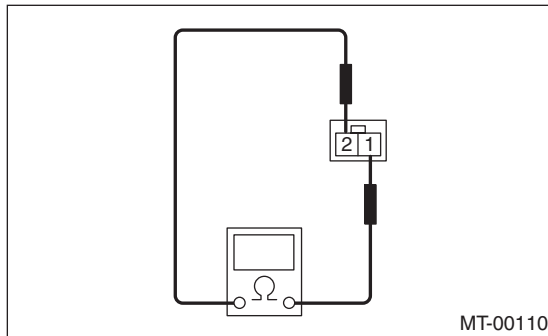

Turbo model:

Gear shift position	Terminal No.	Specified resistance
Neutral position	1 and 3	Less than 1 Ω
Other positions		1 M Ω or more

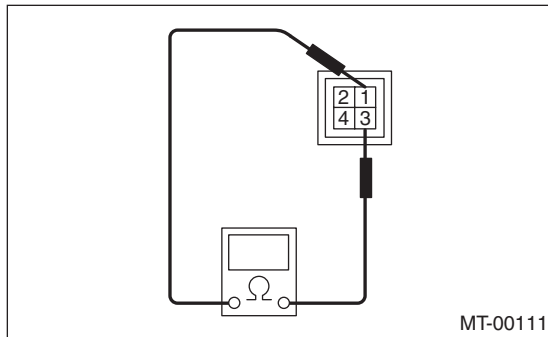

- 4) Replace faulty parts.

8. Vehicle Speed Sensor

A: REMOVAL

- 1) Disconnect the ground cable from battery.
- 2) Lift up the vehicle.
- 3) Remove the front, center and rear exhaust pipes and the muffler.
 - Non-turbo model
<Ref. to EX(H4SO)-4, REMOVAL, Front Exhaust Pipe.> <Ref. to EX(H4SO)-7, REMOVAL, Center Exhaust Pipe.> <Ref. to EX(H4SO)-8, REMOVAL, Rear Exhaust Pipe.> <Ref. to EX(H4SO)-9, REMOVAL, Muffler.>
 - Turbo model
<Ref. to EX(H4DOTC)-8, REMOVAL, Front Exhaust Pipe.> <Ref. to EX(H4DOTC)-10, REMOVAL, Center Exhaust Pipe.> <Ref. to EX(H4DOTC)-15, REMOVAL, Rear Exhaust Pipe.> <Ref. to EX(H4DOTC)-17, REMOVAL, Muffler.>
- 4) Disconnect the connector from vehicle speed sensor.
- 5) Turn the vehicle speed sensor to remove.

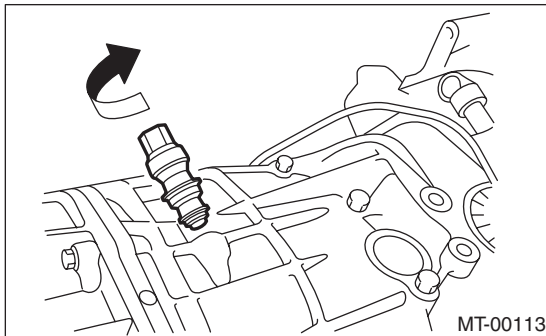

B: INSTALLATION

NOTE:

- Discard the vehicle speed sensor after removal, and replace with a new sensor.
 - Make sure that there is no foreign matter on the sensor mounting.
 - Align the tip end of the key with the key groove on the end of speedometer shaft during installation.
- 1) Hand tighten the vehicle speed sensor.
 - 2) Tighten the vehicle speed sensor using suitable tools.

Tightening torque:

5.9 N·m (0.6 kgf·m, 4.3 ft·lb)

- 3) Connect the connector of the vehicle speed sensor.

- 4) Install the front, center and rear exhaust pipes, and the muffler.

- Non-turbo model

<Ref. to EX(H4SO)-5, INSTALLATION, Front Exhaust Pipe.> <Ref. to EX(H4SO)-7, INSTALLATION, Center Exhaust Pipe.> <Ref. to EX(H4SO)-8, INSTALLATION, Rear Exhaust Pipe.> <Ref. to EX(H4SO)-9, INSTALLATION, Muffler.>

- Turbo model

<Ref. to EX(H4DOTC)-8, INSTALLATION, Front Exhaust Pipe.> <Ref. to EX(H4DOTC)-11, INSTALLATION, Center Exhaust Pipe.> <Ref. to EX(H4DOTC)-15, INSTALLATION, Rear Exhaust Pipe.> <Ref. to EX(H4DOTC)-17, INSTALLATION, Muffler.>

- 5) Lower the vehicle.

- 6) Connect the ground cable to battery.

C: INSPECTION

Because the vehicle speed sensor cannot be inspected by itself, check whether the speedometer is operating properly. If it is not operating properly, check the combination meter system. <Ref. to IDI-3, INSPECTION, Combination Meter System.>

9. Preparation for Overhaul

A: PROCEDURE

- 1) Clean oil, grease, dirt and dust from the transmission.
- 2) Using the TORX® bit T70, remove the drain plug, and drain the transmission gear oil completely.
- 3) Using the TORX® bit T70, tighten the transmission gear oil drain plug.

NOTE:

Use a new gasket.

Tightening torque:

44 N·m (4.5 kgf·m, 32.5 ft·lb) (Aluminum gasket)

70 N·m (7.1 kgf·m, 51.6 ft·lb) (Copper gasket)

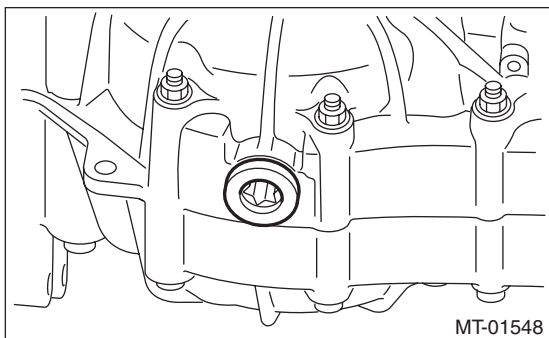

- 4) Attach the transmission to the ST.
ST 499937100 TRANSMISSION STAND

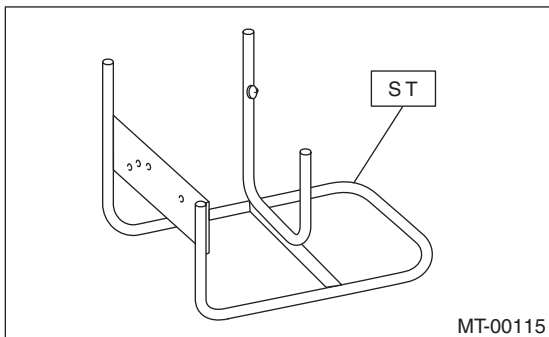

- 5) Apply oil to rotating parts before assembly.
- 6) All disassembled parts, if to be reused, should be reinstalled in the original positions and directions.
- 7) Gaskets, lock washers and lock nuts must be replaced with new parts.
- 8) Apply liquid gasket to the specified areas to prevent leakage.

10. Transfer Case and Extension Case Assembly

A: REMOVAL

- 1) Remove the manual transmission assembly from the vehicle. <Ref. to 5MT-25, REMOVAL, Manual Transmission Assembly.>
- 2) Remove the back-up light switch and the neutral position switch. <Ref. to 5MT-35, REMOVAL, Switches and Harness.>
- 3) Remove the transfer case together with the extension case assembly.

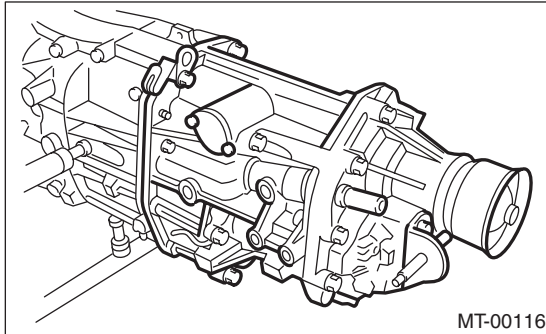

- 4) Remove the shifter arm.
- 5) Remove the extension case assembly.

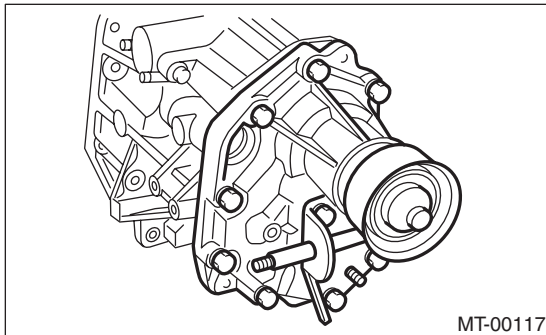

B: INSTALLATION

- 1) Install the center differential and transfer driven gear into the transfer case.

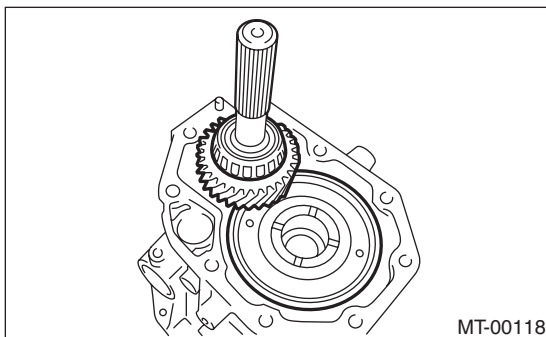

- 2) Remove the bearing outer race from the extension case.

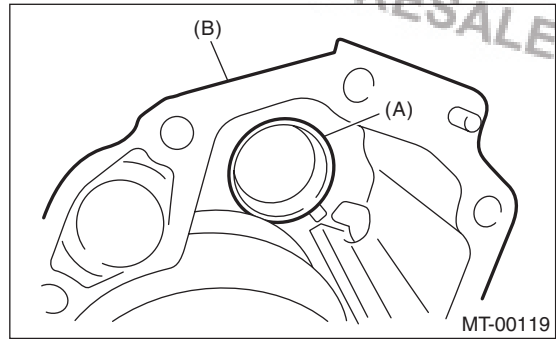

- (A) Bearing outer race
(B) Extension case

- 3) While holding the bearing outer race horizontally, rotate the driven shaft for ten turns.
- 4) Measure the height "W" between transfer case and taper roller bearing on the transfer driven gear.

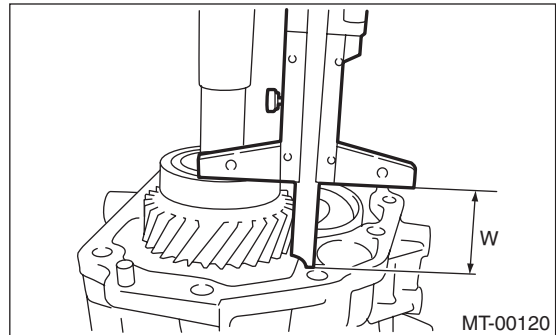

- 5) Measure depth "X" on bearing insertion part of the extension case.

NOTE:

Measure with bearing outer race and thrust washer removed.

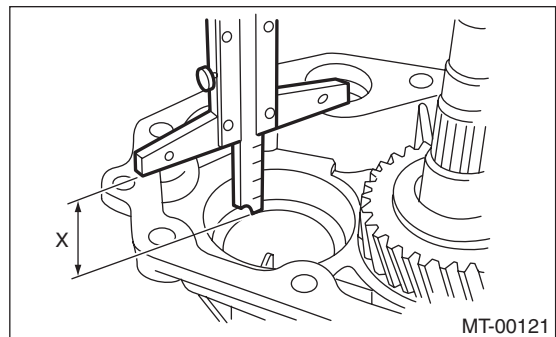

- 6) Calculate the thrust washer thickness "t" using following calculation.

$$t = X - W + (0.2 - 0.3 \text{ mm } (0.008 - 0.012 \text{ in}))$$

Transfer Case and Extension Case Assembly

MANUAL TRANSMISSION AND DIFFERENTIAL

7) Select the washer with the nearest value in the following table.

Taper roller bearing preload (standard protrusion) :

0.2 — 0.3 mm (0.008 — 0.012 in)

NOTE:

Always adjust to the specified range of preload.

Thrust washer (50 × 61 × t)	
Part No.	Thickness mm (in)
803050060	0.50 (0.0197)
803050061	0.55 (0.0217)
803050062	0.60 (0.0236)
803050063	0.65 (0.0256)
803050064	0.70 (0.0276)
803050065	0.75 (0.0295)
803050066	0.80 (0.0315)
803050067	0.85 (0.0335)
803050068	0.90 (0.0354)
803050069	0.95 (0.0374)
803050070	1.00 (0.0394)
803050071	1.05 (0.0413)
803050072	1.10 (0.0433)
803050073	1.15 (0.0453)
803050074	1.20 (0.0472)
803050075	1.25 (0.0492)
803050076	1.30 (0.0512)
803050077	1.35 (0.0531)
803050078	1.40 (0.0551)
803050079	1.45 (0.0571)

8) Fit the thrust washers on the transfer drive shaft.
9) Install the bearing cone into the extension case.
10) Measure the depth "S" between transfer case and center differential.

ST 398643600 GAUGE

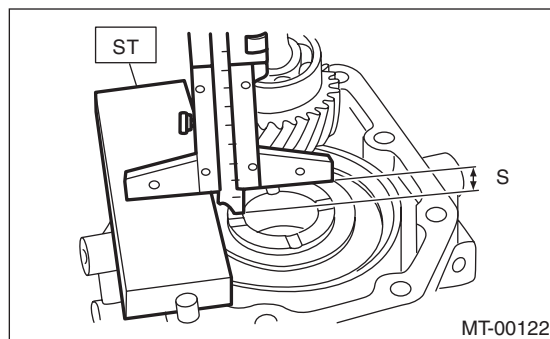

11) Measure the depth "T" between extension case and transfer drive gear.

ST 398643600 GAUGE

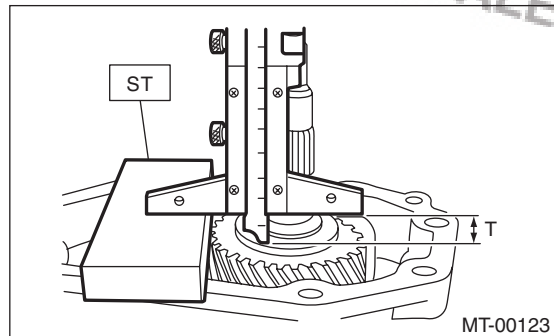

NOTE:

ST thickness [15 mm (0.59 in)]

12) Calculate the thrust washer "U" using the following calculation:

$U = S + T - 30 \text{ mm (1.18 in)}$ [Thickness of ST]

13) Select a suitable washer in the following table.

Standard clearance:

0.15 — 0.35 mm (0.0059 — 0.0138 in)

Thrust washer	
Part No.	Thickness mm (in)
803036050	0.9 (0.035)
803036054	1.0 (0.039)
803036051	1.1 (0.043)
803036055	1.2 (0.047)
803036052	1.3 (0.051)
803036056	1.4 (0.055)
803036053	1.5 (0.059)
803036057	1.6 (0.063)
803036058	1.7 (0.067)

14) Fit the thrust washer onto the center differential.

15) Apply a proper amount of liquid gasket to the transfer case mating surface.

Liquid gasket:

THREE BOND 1215 (Part No. 004403007) or equivalent

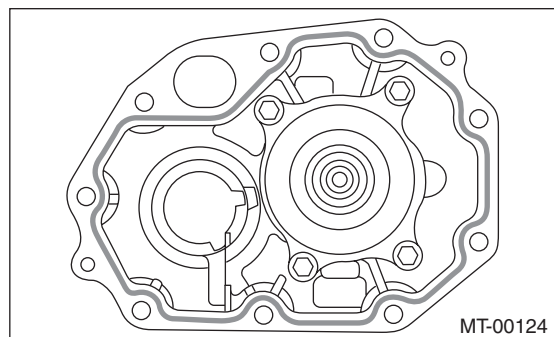

Transfer Case and Extension Case Assembly

MANUAL TRANSMISSION AND DIFFERENTIAL

16) Install the extension assembly into the transfer case.

Tightening torque:

40 N·m (4.1 kgf-m, 29.7 ft-lb)

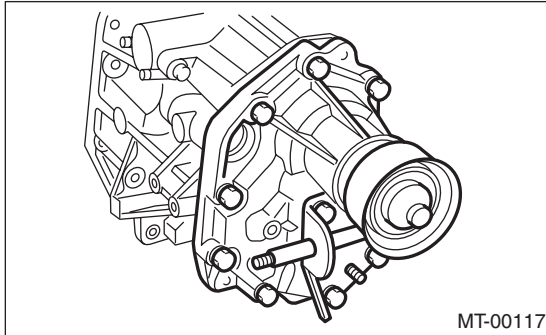

17) Attach the shifter arm to transfer case.

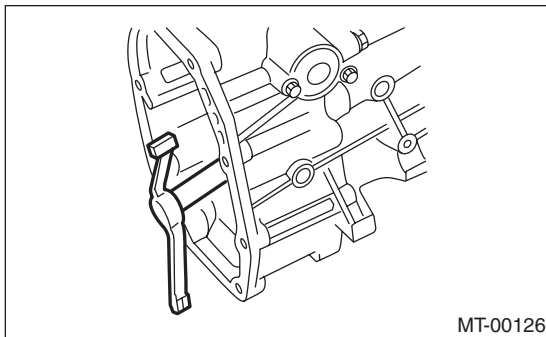

18) Hang the shifter arm on 3rd-4th fork rod.

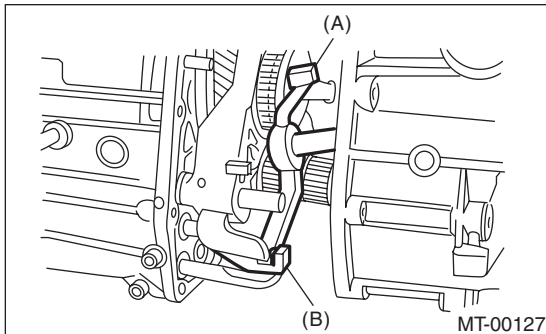

(A) Shifter arm

(B) 3rd-4th fork rod

19) Install the extension case assembly along with the transfer case to the transmission case.

Tightening torque:

24.5 N·m (2.5 kgf-m, 18.1 ft-lb)

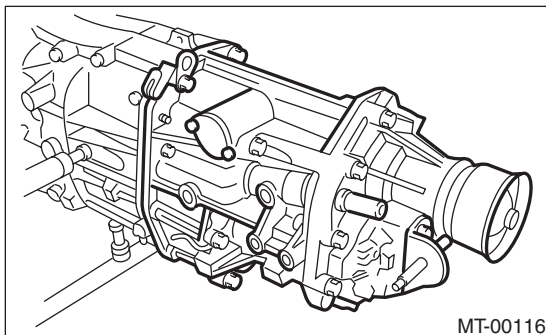

C: DISASSEMBLY

1. TRANSFER CASE

1) Remove the reverse check sleeve assembly. <Ref. to 5MT-48, REMOVAL, Reverse Check Sleeve.>

2) Remove the oil guide.

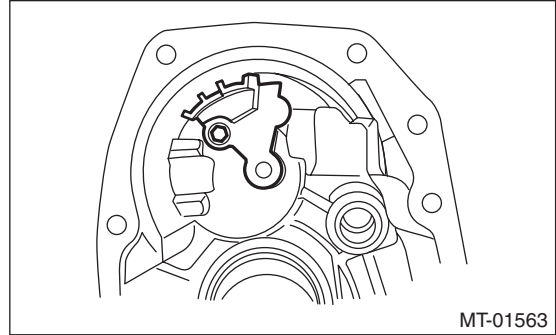

2. EXTENSION CASE

1) Remove the transfer drive gear assembly. <Ref. to 5MT-43, REMOVAL, Transfer Drive Gear.>

2) Remove the shift bracket.

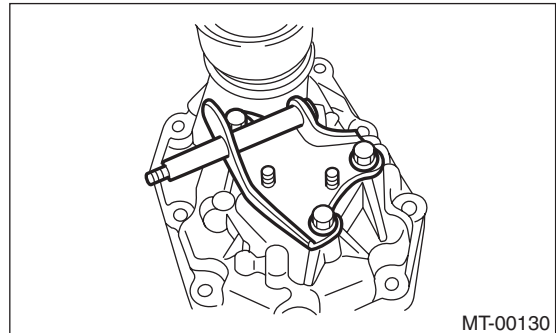

3) Remove the oil seal from the extension case. <Ref. to 5MT-33, Oil Seal.>

Transfer Case and Extension Case Assembly

MANUAL TRANSMISSION AND DIFFERENTIAL

D: ASSEMBLY

1. EXTENSION CASE

1) Using the ST, install the oil seal to the extension case. <Ref. to 5MT-33, Oil Seal.>

NOTE:

Use a new oil seal.

2) Install the shift bracket to extension case.

Tightening torque:

24.5 N·m (2.5 kgf-m, 18.1 ft-lb)

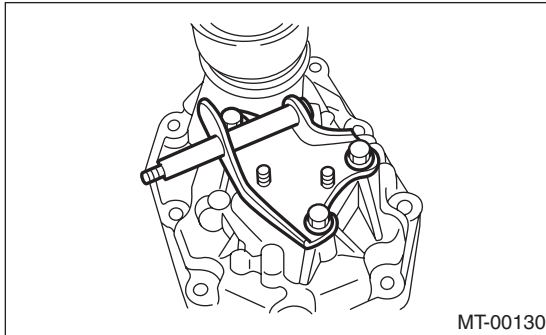

3) Install the transfer drive gear to the extension case. <Ref. to 5MT-43, INSTALLATION, Transfer Drive Gear.>

2. TRANSFER CASE

1) Install the oil guide to the transfer case.

Tightening torque:

6.4 N·m (0.65 kgf-m, 4.7 ft-lb)

NOTE:

Use a new installing bolt.

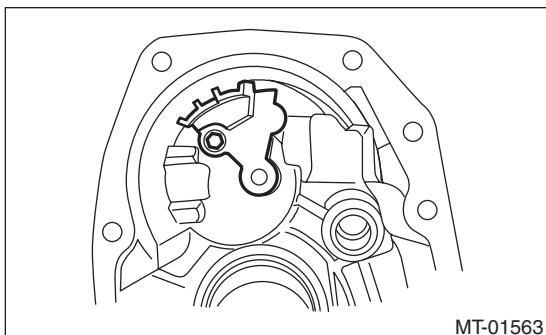

2) Install the reverse check sleeve assembly to the transfer case. <Ref. to 5MT-48, INSTALLATION, Reverse Check Sleeve.>

11. Transfer Drive Gear

A: REMOVAL

- 1) Remove the manual transmission assembly from the vehicle. <Ref. to 5MT-25, REMOVAL, Manual Transmission Assembly.>
- 2) Remove the back-up light switch and the neutral position switch. <Ref. to 5MT-35, REMOVAL, Switches and Harness.>
- 3) Remove the transfer case together with the extension case assembly. <Ref. to 5MT-39, REMOVAL, Transfer Case and Extension Case Assembly.>
- 4) Remove the extension case assembly.
- 5) Remove the transfer driven gear.
- 6) Remove the transfer drive gear.

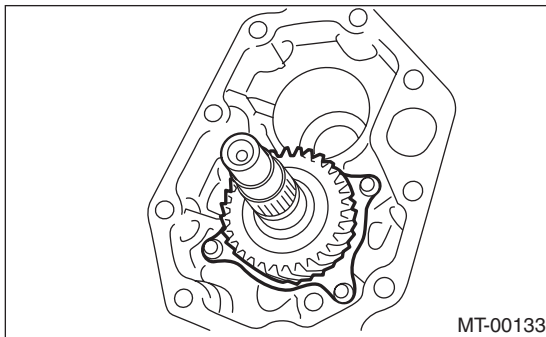

B: INSTALLATION

- 1) Install the transfer drive gear.

Tightening torque:

26 N·m (2.7 kgf·m, 20 ft·lb)

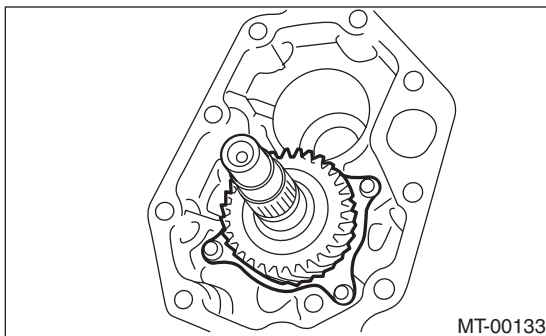

- 2) Install the transfer driven gear.
- 3) Install the extension case assembly.
- 4) Install the transfer case and the extension case assembly. <Ref. to 5MT-39, INSTALLATION, Transfer Case and Extension Case Assembly.>
- 5) Install the back-up light switch & neutral position switch. <Ref. to 5MT-35, INSTALLATION, Switches and Harness.>
- 6) Install the manual transmission assembly to the vehicle. <Ref. to 5MT-28, INSTALLATION, Manual Transmission Assembly.>

C: DISASSEMBLY

- 1) Remove the snap ring.

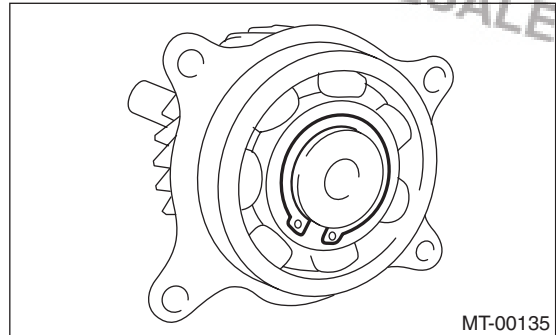

- 2) Remove the ball bearing.

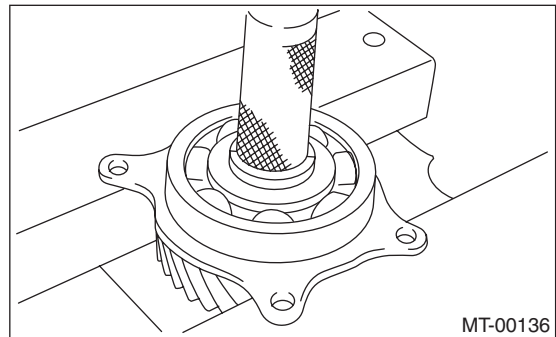

D: ASSEMBLY

- 1) Set the ST against the inner race of the bearing, and install the drive shaft.

ST 398177700 INSTALLER

CAUTION:

Do not apply a load in excess of 10 kN (1 ton, 1.1 US ton, 1.0 Imp ton).

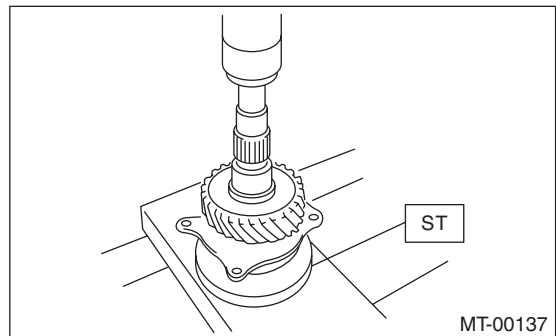

- 2) Install the snap ring on the transfer drive shaft.
- 3) Inspect the clearance between the snap ring and the ball bearing. <Ref. to 5MT-44, INSPECTION, Transfer Drive Gear.>

Brought to you by Eris Studios
NOT FOR RESALE

E: INSPECTION

1) Bearing

Replace the bearings in the following cases.

- In case of broken or rusty bearings
- In case of worn or damaged bearings
- When the bearings fail to turn smoothly or emit noise in rotation after gear oil lubrication.

2) Drive gear

If the drive gear tooth surface and shaft are excessively broken or damaged, replace the drive gear.

3) Measure the clearance between snap ring and inner race of ball bearing with a thickness gauge.

Clearance:

0.01 — 0.15 mm (0.0004 — 0.0059 in)

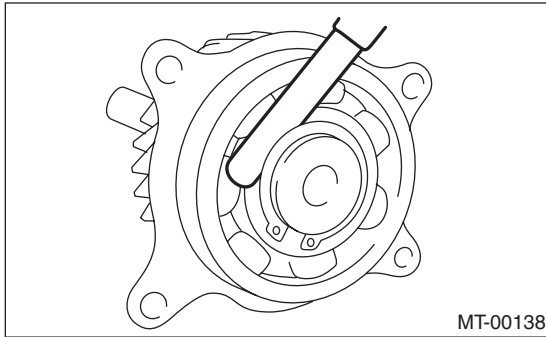

If the measurement is not within specification, select a suitable snap ring and replace it.

Snap ring (Outer-30)	
Part No.	Thickness mm (in)
805030041	1.53 (0.0602)
805030042	1.65 (0.0650)
805030043	1.77 (0.0697)

12. Transfer Driven Gear

A: REMOVAL

- 1) Remove the manual transmission assembly from the vehicle. <Ref. to 5MT-25, REMOVAL, Manual Transmission Assembly.>
- 2) Remove the back-up light switch & neutral position switch. <Ref. to 5MT-35, REMOVAL, Switches and Harness.>
- 3) Remove the transfer case together with the extension case assembly. <Ref. to 5MT-39, REMOVAL, Transfer Case and Extension Case Assembly.>
- 4) Remove the extension case assembly.
- 5) Remove the transfer driven gear.

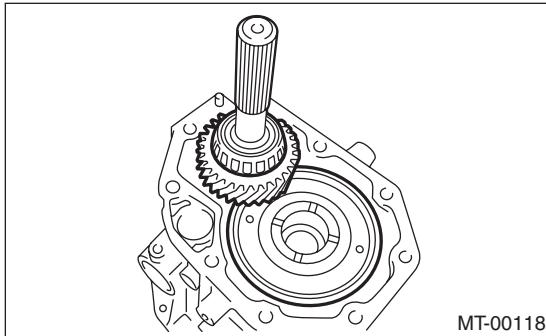

- 6) Remove bearing outer races from the extension case and transfer case.

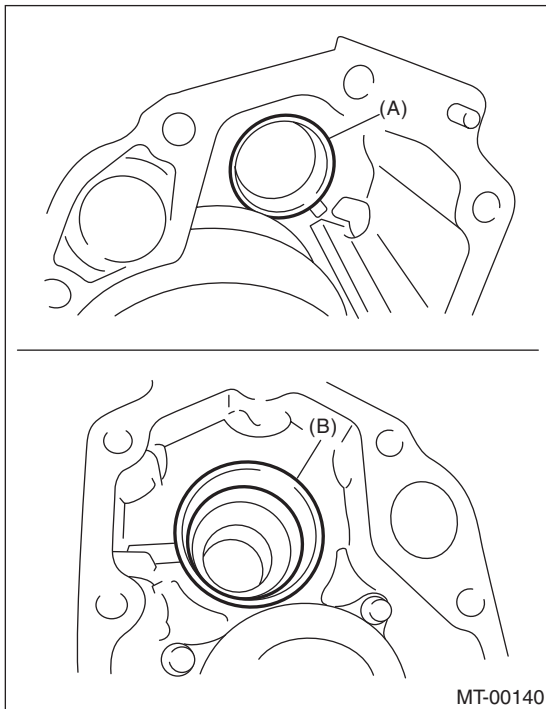

- (A) Bearing outer race (Transfer case side)
- (B) Bearing outer race (Extension case side)

B: INSTALLATION

- 1) Install the bearing outer races to extension case and transfer case.

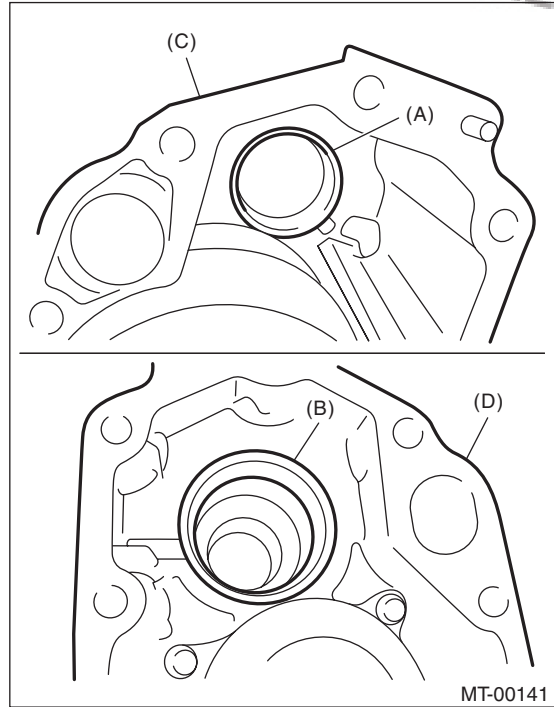

- (A) Bearing outer race
- (B) Bearing outer race
- (C) Transfer case
- (D) Extension case

- 2) Install the transfer driven gear.

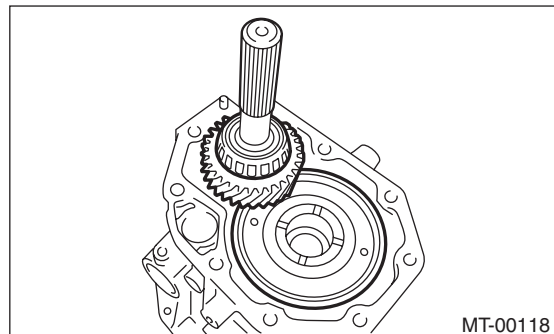

- 3) Install the transfer case and the extension case assembly. <Ref. to 5MT-39, INSTALLATION, Transfer Case and Extension Case Assembly.>
- 4) Install the back-up light switch & neutral position switch. <Ref. to 5MT-35, INSTALLATION, Switches and Harness.>
- 5) Install the manual transmission assembly to the vehicle. <Ref. to 5MT-28, INSTALLATION, Manual Transmission Assembly.>

Transfer Driven Gear

MANUAL TRANSMISSION AND DIFFERENTIAL

C: DISASSEMBLY

1) Using the ST, remove the roller bearing (extension case side).

ST 498077000 REMOVER

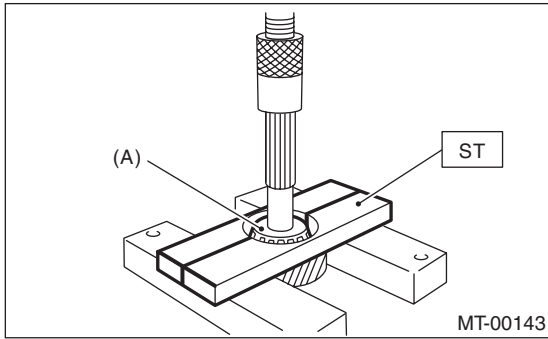

(A) Roller bearing

2) Using ST1 and ST2, remove the roller bearing (transfer case side).

ST1 498077000 REMOVER

ST2 899864100 REMOVER

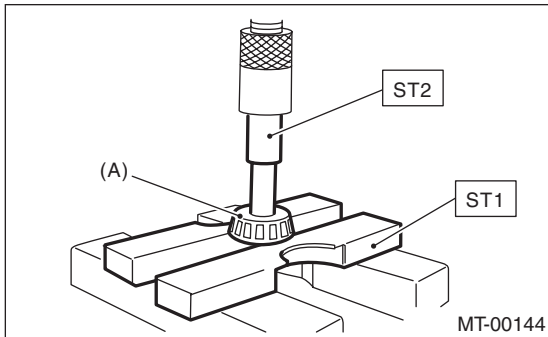

(A) Roller bearing

D: ASSEMBLY

1) Using the ST, install the roller bearing (extension case side).

ST1 398177700 INSTALLER

ST2 899864100 REMOVER

CAUTION:

Do not apply a load in excess of 10 kN (1 ton, 1.1 US ton, 1.0 Imp ton).

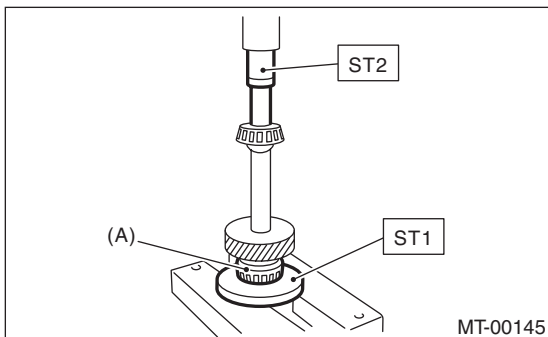

(A) Roller bearing

2) Using ST, install the roller bearing (transfer case side).

ST 499757002 INSTALLER

CAUTION:

Do not apply a load in excess of 10 kN (1 ton, 1.1 US ton, 1.0 Imp ton).

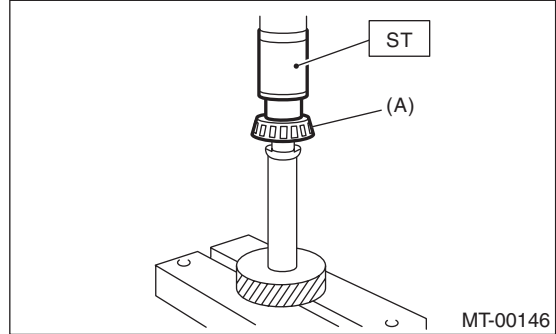

(A) Roller bearing

E: INSPECTION

1) Bearing

Replace the bearings in the following cases.

- In case of broken or rusty bearings
- In case of worn or damaged bearings
- When the bearings fail to turn smoothly or emit noise in rotation after gear oil lubrication.

2) Driven gear

If the driven gear tooth surface and shaft are excessively broken or damaged, replace the driven gear.

13.Center Differential

A: REMOVAL

- 1) Remove the manual transmission assembly from the vehicle. <Ref. to 5MT-25, REMOVAL, Manual Transmission Assembly.>
- 2) Remove the transfer case together with the extension case assembly. <Ref. to 5MT-39, REMOVAL, Transfer Case and Extension Case Assembly.>
- 3) Remove the extension case assembly. <Ref. to 5MT-39, REMOVAL, Transfer Case and Extension Case Assembly.>
- 4) Remove the transfer driven gear. <Ref. to 5MT-45, REMOVAL, Transfer Driven Gear.>
- 5) Remove the center differential.

B: INSTALLATION

- 1) Install the center differential into transfer case.
- 2) Install the transfer driven gear. <Ref. to 5MT-45, INSTALLATION, Transfer Driven Gear.>
- 3) Install the extension case assembly. <Ref. to 5MT-39, INSTALLATION, Transfer Case and Extension Case Assembly.>
- 4) Install the transfer case together with the extension case assembly. <Ref. to 5MT-39, INSTALLATION, Transfer Case and Extension Case Assembly.>
- 5) Install the back-up light switch & neutral position switch. <Ref. to 5MT-35, INSTALLATION, Switches and Harness.>
- 6) Install the manual transmission assembly to the vehicle. <Ref. to 5MT-28, INSTALLATION, Manual Transmission Assembly.>

C: DISASSEMBLY

- Center differential is a non-disassembled part which should not be disassembled.
- Remove the ball bearing using ST.
- Do not reuse the ball bearing.

ST 498077300 CENTER DIFFERENTIAL
BEARING REMOVER

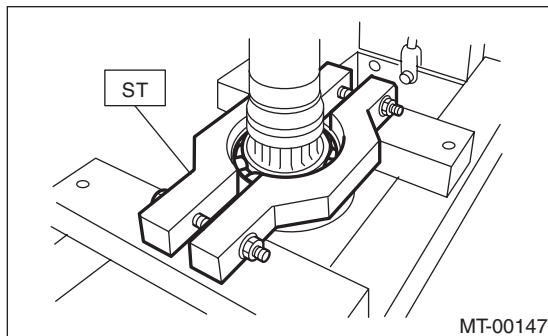

D: ASSEMBLY

Install the ball bearing into the center differential assembly.

CAUTION:

Do not apply a load in excess of 10 kN (1 ton, 1.1 US ton, 1.0 Imp ton).

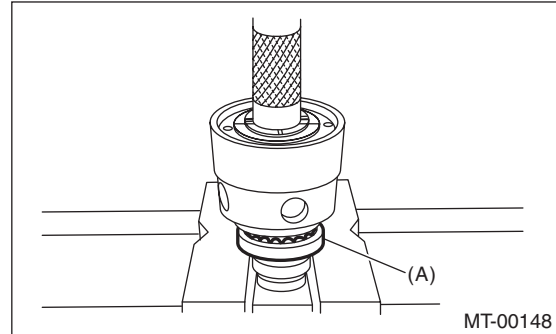

(A) Ball bearing

E: INSPECTION

1) Bearing

Replace the bearings in the following cases.

- In case of broken or rusty bearings
- In case of worn or damaged bearings
- When the bearings fail to turn smoothly or emit noise in rotation after gear oil lubrication.
- When bearing has other defects.

2) Center differential

Replace the center differential case assembly if worn or damaged.

Reverse Check Sleeve

MANUAL TRANSMISSION AND DIFFERENTIAL

14. Reverse Check Sleeve

A: REMOVAL

- 1) Remove the manual transmission assembly from the vehicle. <Ref. to 5MT-25, REMOVAL, Manual Transmission Assembly.>
- 2) Remove the transfer case together with the extension case assembly. <Ref. to 5MT-39, REMOVAL, Transfer Case and Extension Case Assembly.>
- 3) Remove the shifter arm.
- 4) Remove the plug, gasket, reverse accent spring, and reverse check ball.

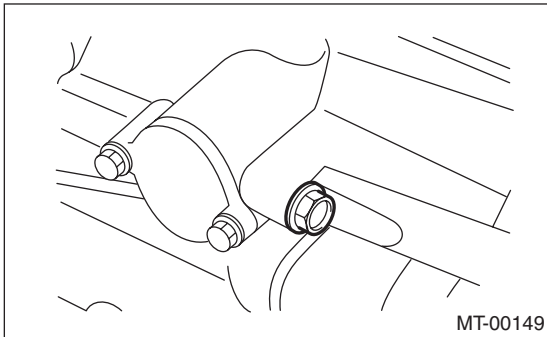

- 5) Remove the reverse check sleeve.

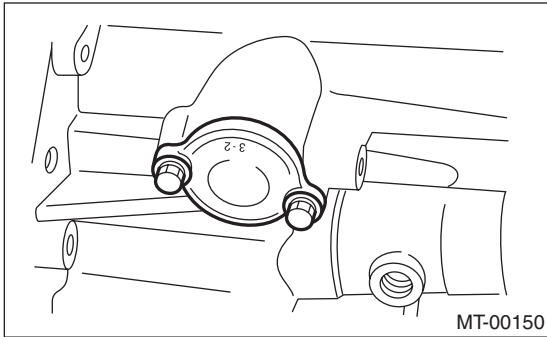

B: INSTALLATION

- 1) Install the reverse check sleeve.

Tightening torque:

6.4 N·m (0.65 kgf-m, 4.7 ft-lb)

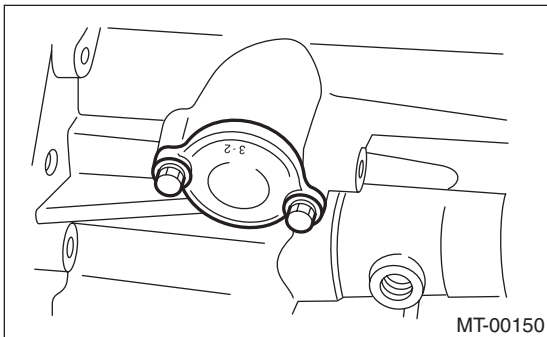

- 2) Install reverse check ball, reverse accent spring, gasket and plug to the transfer case.

Tightening torque:

9.75 N·m (1.0 kgf-m, 7.2 ft-lb)

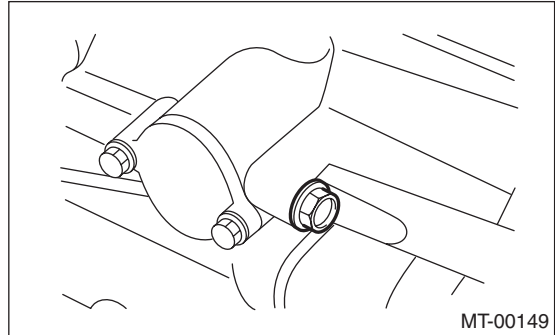

- 3) Attach the shifter arm to the transfer case assembly.
- 4) Install the transfer case together with the extension case assembly. <Ref. to 5MT-39, INSTALLATION, Transfer Case and Extension Case Assembly.>
- 5) Install the manual transmission assembly to the vehicle. <Ref. to 5MT-28, INSTALLATION, Manual Transmission Assembly.>

C: DISASSEMBLY

- 1) Cover the reverse check sleeve with a rag, and remove the snap ring using a screwdriver.

NOTE:

Replace the snap ring with a new part if it is deformed or spring force is weakened.

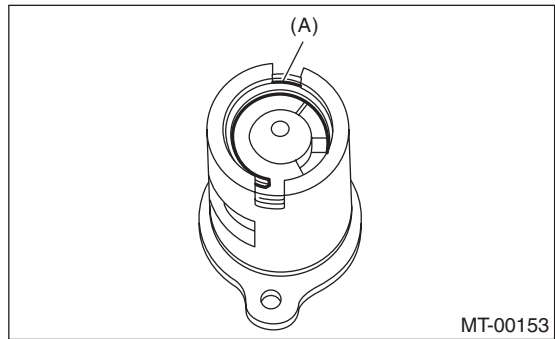

(A) Snap ring

2) Remove the reverse check plate, reverse check spring, reverse check cam, return spring (5th-Rev), reverse accent shaft, return spring cap and return spring (1st-2nd).

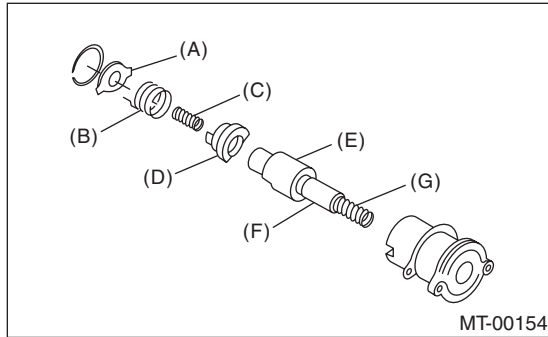

- (A) Reverse check plate
- (B) Reverse check spring
- (C) Return spring (5th-Rev)
- (D) Reverse check cam
- (E) Reverse accent shaft
- (F) Return spring cap
- (G) Return spring (1st-2nd)

3) Remove the O-ring.

NOTE:

- Visually check the O-ring. Replace if faulty.
- Be careful not to damage the adjusting shim between reverse check sleeve assembly and the case.

D: ASSEMBLY

1) Install the return spring (1st-2nd), return spring cap, reverse accent shaft, reverse check cam, return spring (5th-Rev) and check spring to the reverse check sleeve.

NOTE:

Be sure to position the bent section of reverse check spring to fit in the groove of the check cam.

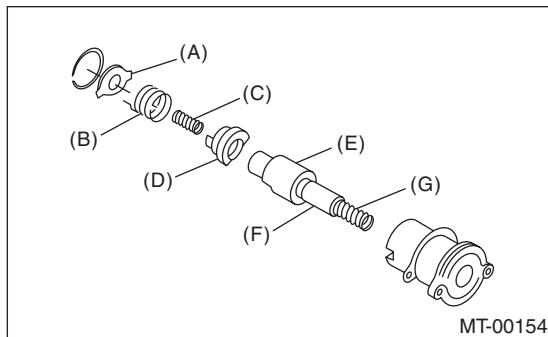

- (A) Reverse check plate
- (B) Reverse check spring
- (C) Return spring (5th-Rev)
- (D) Reverse check cam
- (E) Reverse accent shaft
- (F) Return spring cap
- (G) Return spring (1st-2nd)

2) Hook the curved section of the reverse check spring over the reverse check plate.

3) Rotate the cam so that the protrusion of the reverse check cam comes to the opening of the plate.

4) With cam held in that position, install the reverse check plate onto the reverse check sleeve and hold in place with the snap ring.

5) Position the new O-ring in the groove of sleeve.

E: INSPECTION

- Make sure the cutout of the reverse accent shaft is aligned with the opening in the reverse check sleeve.
 - Turn the cam by hand to check for smooth rotation.
 - Move the cam and shaft all the way toward the plate, and make sure it releases.
- If the cam does not return properly, replace the reverse check spring. If the shaft does not return, check for scratches on the inner surface of sleeve. If the sleeve is in good order, replace the spring.

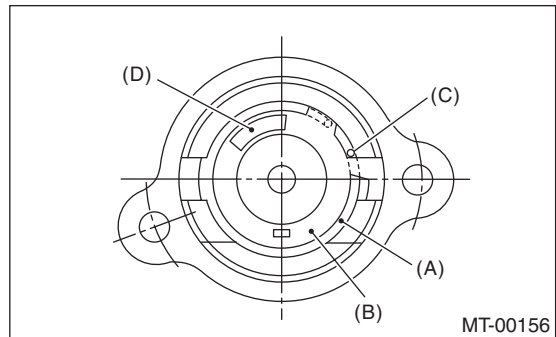

- (A) Snap ring
- (B) Reverse check plate
- (C) Checking spring
- (D) Check cam

- Select a suitable reverse accent shaft and reverse check plate. <Ref. to 5MT-50, ADJUSTMENT, Reverse Check Sleeve.>

Reverse Check Sleeve

MANUAL TRANSMISSION AND DIFFERENTIAL

F: ADJUSTMENT

1. NEUTRAL POSITION ADJUSTMENT

- 1) Shift the gear into 3rd gear position.
- 2) Because of the return spring function, until the arm contacts the stopper the shifter arm will feel lighter moving towards 1st/2nd gear and heavier towards the reverse gear.
- 3) Make adjustment so that the heavy stroke (reverse side) is a little heavier than the lighter stroke (1st/2nd side).
- 4) To adjust, remove the bolts holding the reverse check sleeve assembly to the case, and move the sleeve assembly outward, then place an adjustment shim between the sleeve assembly and the case to adjust the clearance.

CAUTION:

Be careful not to damage the O-ring when placing shims.

NOTE:

- When the shim is removed, the neutral position will move closer to reverse; when the shim is added, the neutral position will move closer to 1st gear.
- If it is not possible to adjust the clearance with only shims, replace the reverse accent shaft and re-adjust.

Adjusting shim	
Part No.	Thickness mm (in)
32190AA000	0.15 (0.0059)
32190AA010	0.30 (0.0118)

Reverse accent shaft		
Part No.	Mark	Remarks
32188AA130	S	Neutral position is closer to 1st gear.
32188AA140	T	Standard
32188AA150	U	Neutral position is closer to reverse gear.

2. REVERSE CHECK PLATE ADJUSTMENT

- 1) Shift the shifter arm to "5th" and then to reverse to see if the reverse check mechanism operates properly.
- 2) Also check to see if the arm returns to neutral when released from the reverse position. If the arm does not return properly, replace the reverse check plate.

Reverse check plate			
Part No.	(A): No.	Angle θ	Remarks
32189AA001	0	28°	Arm stops closer to 5th gear.
32189AA011	1	31°	Arm stops closer to 5th gear.
32189AA021	2	34°	Arm stops in the center.
32189AA031	3	37°	Arm stops closer to reverse gear.
32189AA041	4	40°	Arm stops closer to reverse gear.

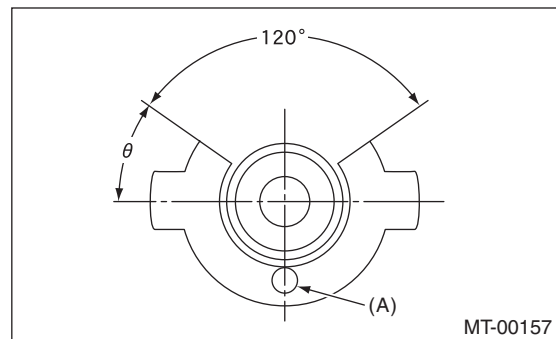

15. Transmission Case

A: REMOVAL

- 1) Remove the manual transmission assembly from the vehicle. <Ref. to 5MT-25, REMOVAL, Manual Transmission Assembly.>
- 2) Remove the clutch release lever. <Ref. to CL-18, REMOVAL, Release Bearing and Lever.>
- 3) Remove the transfer case together with the extension case assembly. <Ref. to 5MT-39, REMOVAL, Transfer Case and Extension Case Assembly.>
- 4) Remove the bearing mounting bolt.

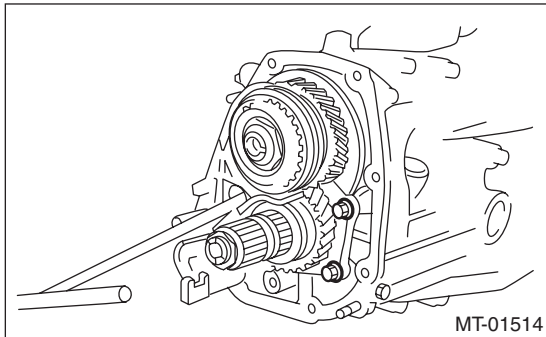

- 5) Remove the main shaft rear plate.

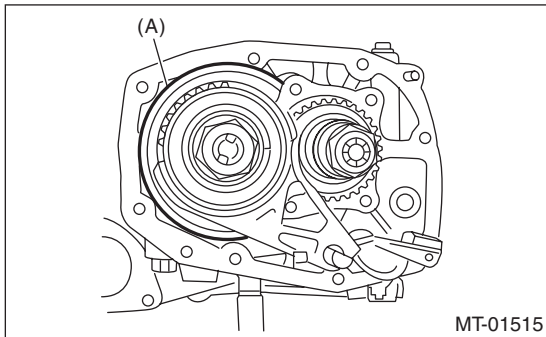

(A) Main shaft rear plate

- 6) Separate the transmission case into the right and left cases by loosening the coupling bolts and nuts.

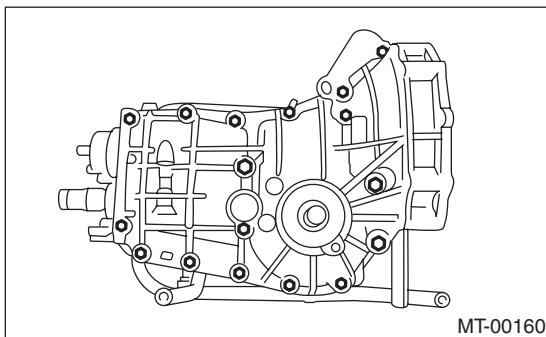

- 7) Remove the drive pinion shaft assembly from the left side of the transmission case.

NOTE:

Use a hammer handle, etc. to remove if too tight.

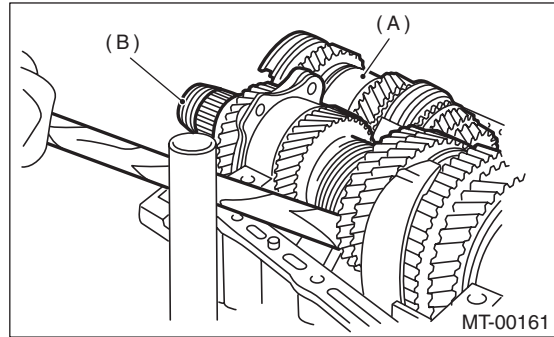

(A) Main shaft ASSY

(B) Drive pinion shaft ASSY

- 8) Remove the main shaft assembly.
- 9) Remove the front differential assembly.

NOTE:

- Do not confuse the right and left roller bearing outer races.
- Be careful not to damage the oil seal of retainer.

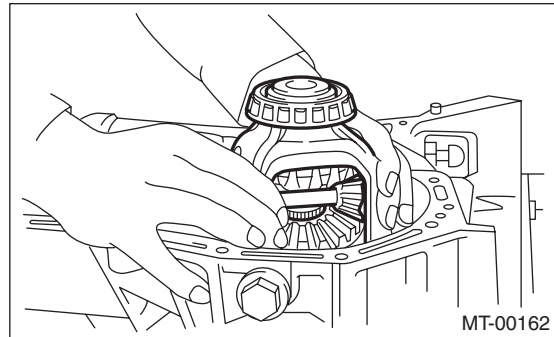

B: INSTALLATION

- 1) Wipe off grease, oil and dust on the mating surfaces of transmission cases with cleaning solvent.
- 2) Install the front differential assembly.
- 3) Install the main shaft assembly.
Install the transmission case knock pin into the knock pin hole of needle bearing.
- 4) Install the drive pinion shaft assembly.
Install the transmission case knock pin into the roller bearing knock pin hole.
- 5) Apply liquid gasket, and then join the right side and left side of the case together.

Liquid gasket:

THREE BOND 1215 (Part No. 004403007) or equivalent

Transmission Case

MANUAL TRANSMISSION AND DIFFERENTIAL

6) With brackets and clips as shown in the figure, tighten the 17 bolts.

NOTE:

- Insert the bolts from the bottom and tighten the nuts at the top.
- Put the cases together so that the drive pinion shim and input shaft holder shims are not caught in between.
- Check that the speedometer gears are mating correctly.

Tightening torque:

8 mm bolt

25 N·m (2.5 kgf-m, 18.4 ft-lb)

★ **10 mm bolt**

39 N·m (4.0 kgf-m, 28.9 ft-lb)

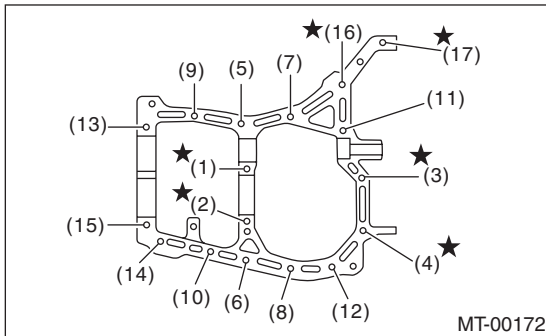

7) Tighten the ball bearing mounting bolts.

Tightening torque:

30 N·m (3.1 kgf-m, 22.1 ft-lb)

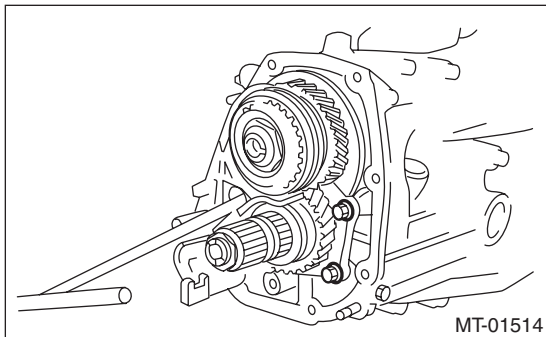

8) Perform backlash adjustment of the hypoid gear and preload measurement of the roller bearing:

NOTE:

Support the drive pinion shaft assembly with the ST.

ST 498427100 STOPPER

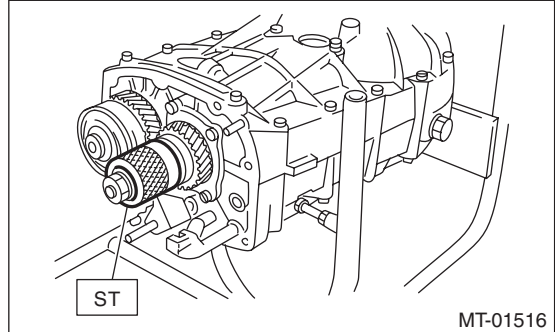

9) Place the transmission with the left side of case facing downward, and put ST1 on bearing cup.

10) Screw the retainer assembly from the bottom into left case using ST2. Fit the ST3 on transmission main shaft. Shift the gear into 4th or 5th, and turn the shaft several times. Screw in the retainer while rotating the ST3 until a slight resistance is felt on ST2.

This is the contact point of the hypoid gear and the drive pinion shaft. Repeat the above sequence several times to ensure the contact point.

ST1 399780104 WEIGHT

ST2 18630AA010 WRENCH COMPL RETAINER

ST3 499927100 HANDLE

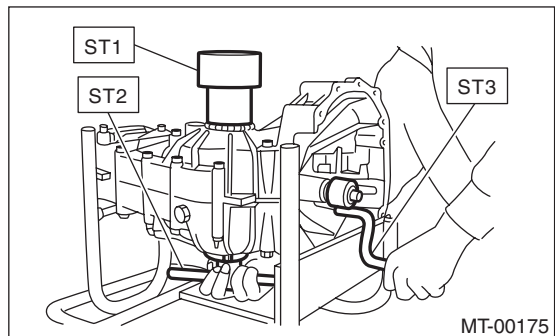

Transmission Case

MANUAL TRANSMISSION AND DIFFERENTIAL

11) Remove the weight, and screw in the retainer without the O-ring on the upper side, and stop at the point where a slight resistance is felt.

NOTE:

In this condition, the backlash between hypoid gear and drive pinion shaft is zero.

ST 18630AA010 WRENCH COMPL RETAINER

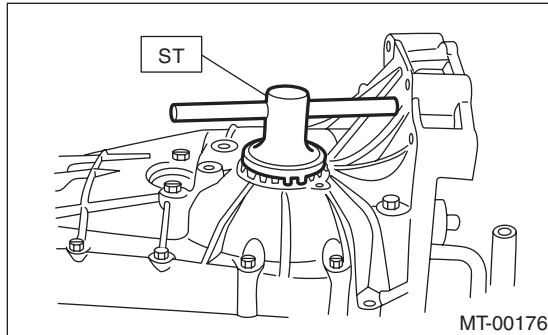

12) Loosen the retainer on the lower side by 3 notches and turn the retainer on the upper side by the same amount in order to apply backlash.

13) Rotate the retainer of the upper side additionally by 1 notch in order to apply preload on taper roller bearing.

14) Tighten temporarily both the upper and lower lock plates, and put marks both the holder and lock plate for later readjustment.

NOTE:

If it is hard to install the lock plates, reverse the sides and install them.

15) Turn the transmission main shaft several times while tapping around the retainer lightly with plastic hammer.

16) Inspect and adjust backlash and tooth contact of the hypoid gear. <Ref. to 5MT-71, INSPECTION, Front Differential Assembly.>

17) After checking the tooth contact of the hypoid gears, remove the lock plate. Then loosen the retainer until the O-ring groove appears. Fit the O-ring into the groove and tighten the retainer into the position where retainer was tightened previously. Install the lock plate.

NOTE:

- Count number of turns while loosening retainer and record it.
- Perform this for both upper and lower retainers.

Tightening torque:

T: 25 N·m (2.5 kgf-m, 18.4 ft-lb)

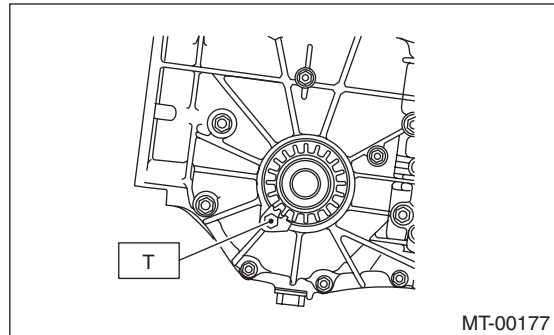

18) Select the main shaft rear plate. <Ref. to 5MT-58, ADJUSTMENT, Main Shaft Assembly.>

19) Install the clutch release lever and bearing. <Ref. to CL-18, INSTALLATION, Release Bearing and Lever.>

20) Install the transfer case together with the extension case assembly. <Ref. to 5MT-39, INSTALLATION, Transfer Case and Extension Case Assembly.>

21) Install the manual transmission assembly to the vehicle. <Ref. to 5MT-28, INSTALLATION, Manual Transmission Assembly.>

C: INSPECTION

Check the transmission case for cracks, damage, or oil leaks.

16. Main Shaft Assembly

A: REMOVAL

- 1) Remove the manual transmission assembly from the vehicle. <Ref. to 5MT-25, REMOVAL, Manual Transmission Assembly.>
- 2) Remove the transfer case together with the extension case assembly. <Ref. to 5MT-39, REMOVAL, Transfer Case and Extension Case Assembly.>
- 3) Remove the transmission case. <Ref. to 5MT-51, REMOVAL, Transmission Case.>
- 4) Remove the drive pinion shaft assembly. <Ref. to 5MT-59, REMOVAL, Drive Pinion Shaft Assembly.>
- 5) Remove the main shaft assembly.

B: INSTALLATION

- 1) Attach the needle bearing and oil seal to the front of the transmission main shaft assembly.

NOTE:

- Wrap the clutch splined section with vinyl tape to prevent damage to the oil seal.
- Apply UNILUBE #2 (or equivalent) to the sealing lip of the oil seal.
- Use a new oil seal.

- 2) Install the transmission case knock pin into the knock pin hole of the needle bearing outer race.

NOTE:

Align the end face of the seal with surface (A) when installing the oil seal.

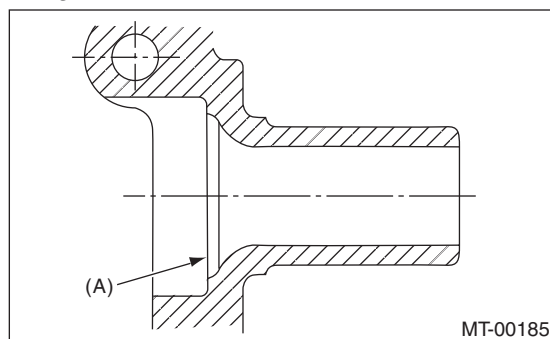

- 3) Install the drive pinion shaft assembly. <Ref. to 5MT-59, INSTALLATION, Drive Pinion Shaft Assembly.>
- 4) Install the transmission case. <Ref. to 5MT-51, INSTALLATION, Transmission Case.>
- 5) Install the transfer case together with the extension case assembly. <Ref. to 5MT-39, INSTALLATION, Transfer Case and Extension Case Assembly.>
- 6) Install the manual transmission assembly to the vehicle. <Ref. to 5MT-28, INSTALLATION, Manual Transmission Assembly.>

C: DISASSEMBLY

- 1) Put vinyl tape around main shaft spline to protect the oil seal from damage. Then pull out the oil seal and needle bearing by hand.
- 2) Remove the lock nut from the transmission main shaft assembly.

NOTE:

Flatten the lock nut tab before removing the lock nut.

- | | | |
|-----|-----------|---------------------|
| ST1 | 498937000 | TRANSMISSION HOLDER |
| ST2 | 499987003 | SOCKET WRENCH (35) |

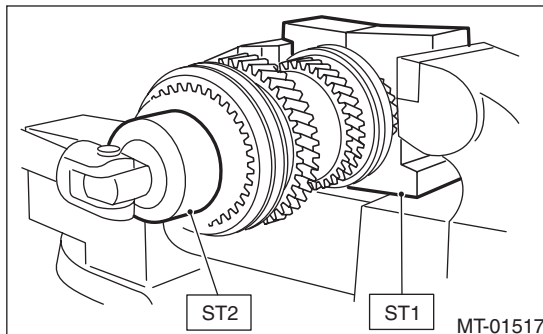

- 3) Remove the 5th hub & sleeve No. 2, baulk lever, baulk ring, 5th drive gear & needle bearing.

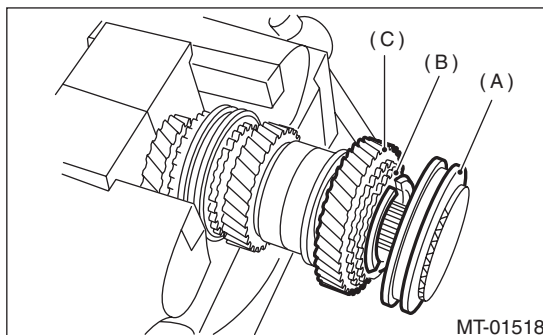

- | | |
|-----|------------------------|
| (A) | 5th hub & sleeve No. 2 |
| (B) | Baulk ring |
| (C) | 5th drive gear |

Main Shaft Assembly

MANUAL TRANSMISSION AND DIFFERENTIAL

4) Using ST1 and ST2, remove the rest of the parts.

NOTE:

- When replacing the sleeve & hub, replace them as a set.
- Do not disassemble the sleeve & hub; the aligning position is pre-matched.
- If it is necessary to disassemble, mark the engaging points on the splines beforehand.

ST1 899864100 REMOVER

ST2 899714110 REMOVER

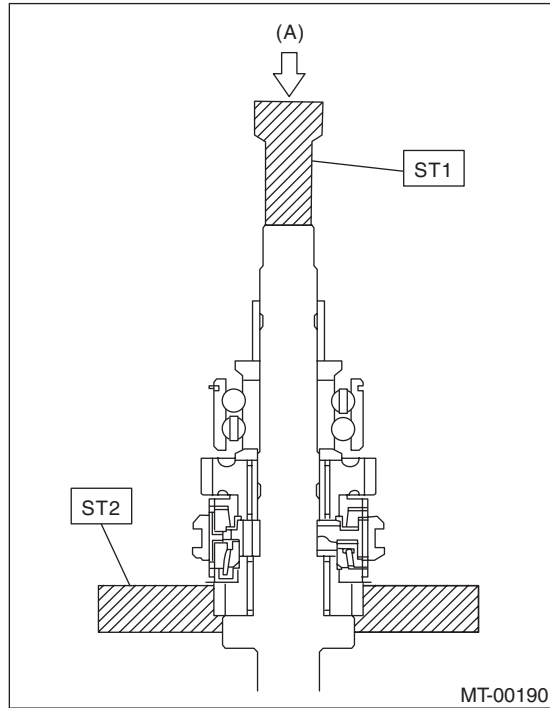

(A) Press

D: ASSEMBLY

1) When the sleeve & hub assemblies have been disassembled, reassemble by aligning the alignment marks.

NOTE:

Position the open ends of the spring 120° apart.

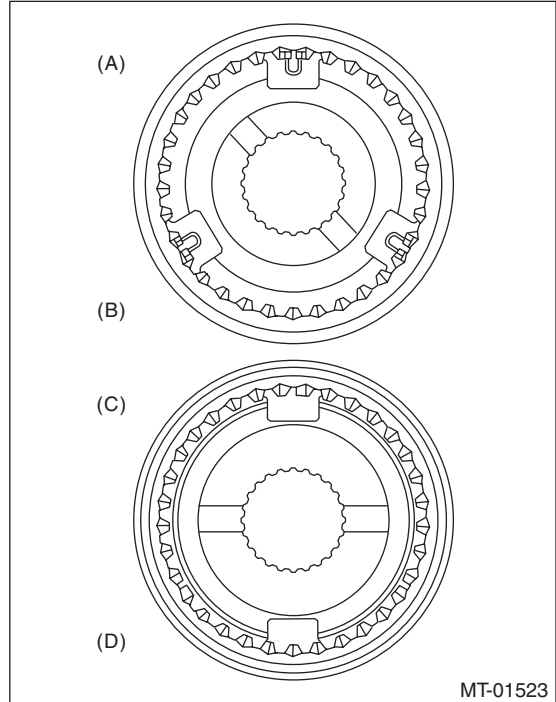

- (A) 3rd-4th hub ASSY
- (B) 3rd gear side
- (C) 5th hub & sleeve No. 2
- (D) 5th gear side

Main Shaft Assembly

MANUAL TRANSMISSION AND DIFFERENTIAL

2) Install the 3rd drive gear, outer baulk ring, synchro cone, inner baulk ring, sleeve & hub assembly for the 3rd needle bearing, on the transmission main shaft.

NOTE:

Align the groove in baulk ring with the shifting insert.

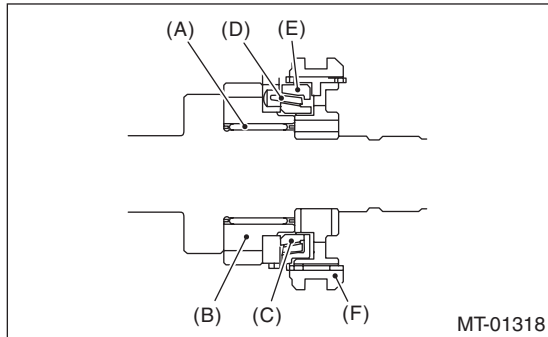

- (A) 3rd needle bearing
- (B) 3rd drive gear
- (C) Inner baulk ring
- (D) Synchro cone
- (E) Outer baulk ring
- (F) Sleeve & hub ASSY

3) Install the 4th needle bearing race onto transmission main shaft using ST1, ST2 and press.

CAUTION:

Do not apply a load in excess of 10 kN (1 ton, 1.1 US ton, 1.0 Imp ton).

ST1 899714110 REMOVER

ST2 499877000 RACE 4-5 INSTALLER

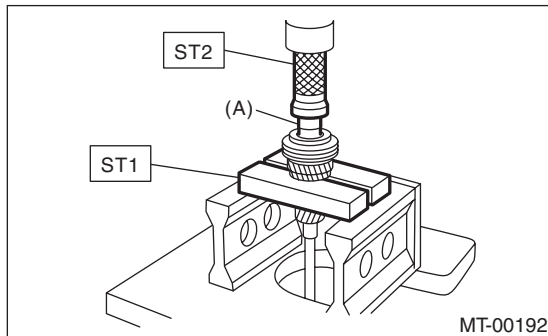

- (A) 4th needle bearing race

4) Install the baulk ring, needle bearing, 4th drive gear and 4th gear thrust washer to the transmission main shaft.

NOTE:

Align the baulk ring and gear & hub assembly with the key groove.

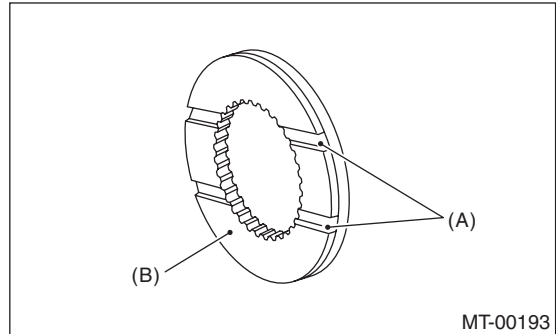

- (A) Groove
- (B) Face this surface to the 4th gear side.

5) Press-fit the ball bearing into the rear section of transmission main shaft using ST1, ST2 and a press.

CAUTION:

Do not apply a load in excess of 10 kN (1 ton, 1.1 US ton, 1.0 Imp ton).

ST1 899714110 REMOVER

ST2 499877000 RACE 4-5 INSTALLER

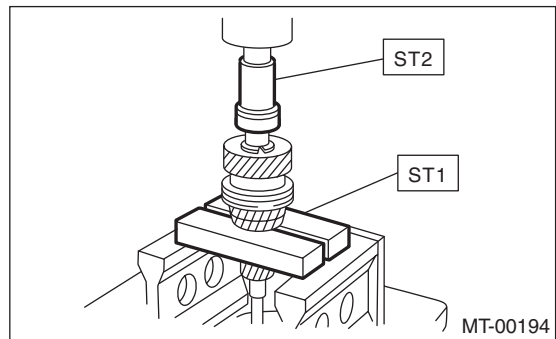

Main Shaft Assembly

MANUAL TRANSMISSION AND DIFFERENTIAL

6) Using the ST1 and ST2, install the 5th gear thrust washer and 5th needle bearing race onto the rear section of transmission main shaft.

CAUTION:

Do not apply a load in excess of 10 kN (1 ton, 1.1 US ton, 1.0 Imp ton).

NOTE:

Make sure the thrust washer is oriented in the correct direction.

ST1 899714110 REMOVER

ST2 499877000 RACE 4-5 INSTALLER

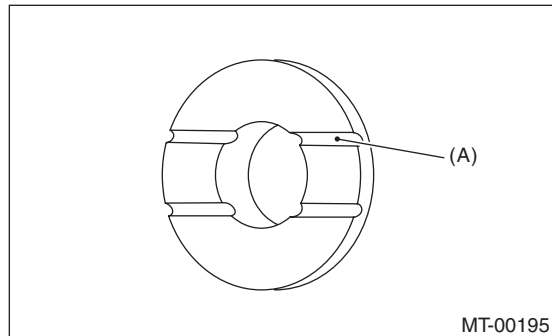

(A) Face this surface to the 5th gear side.

7) Install rest of the parts to the rear section of the transmission main shaft.

CAUTION:

• **Install the baulk lever so that the concave side faces toward the 5th hub.**

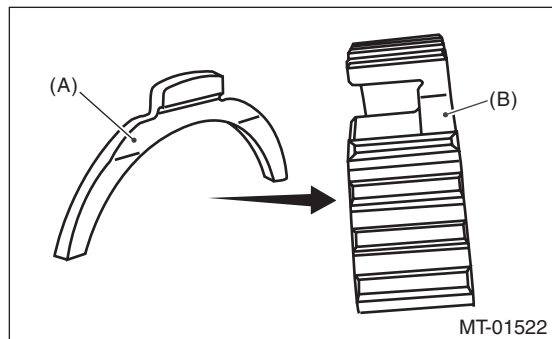

(A) Baulk lever
(B) 5th hub

• **Fit the convex portions of baulk ring with the gaps between baulk levers.**

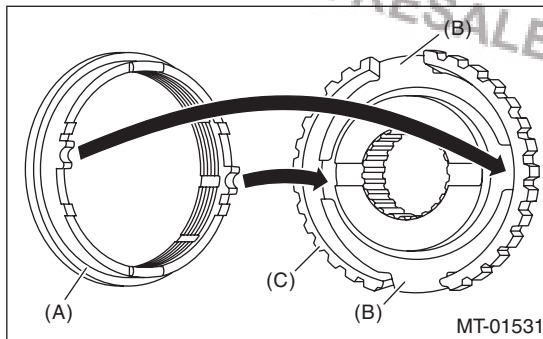

(A) Baulk ring
(B) Baulk lever
(C) 5th hub

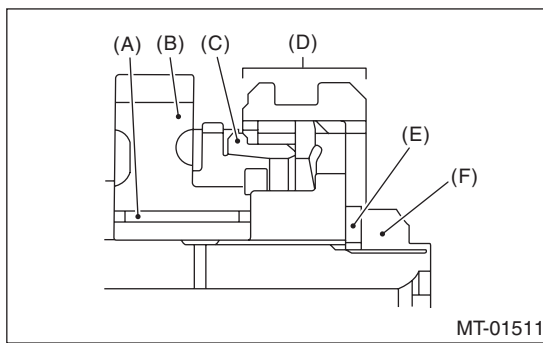

(A) Needle bearing
(B) 5th drive gear
(C) Baulk ring
(D) 5th hub & sleeve No. 2
(E) Lock washer
(F) Lock nut

8) Tighten new lock nuts to the specified torque using ST1 and ST2.

9) Crimp lock nuts in two locations after tightening.

ST1 499987003 SOCKET WRENCH (35)

ST2 498937000 TRANSMISSION HOLDER

Tightening torque:

120 N·m (12.2 kgf·m, 88.5 ft·lb)

Main Shaft Assembly

MANUAL TRANSMISSION AND DIFFERENTIAL

E: INSPECTION

Disassembled parts should be washed clean first with cleaning solvent and then inspected carefully.

1) Bearing

Replace the bearings in the following cases.

- When the bearing balls, outer races and inner races are broken or rusty.
- When the bearing is worn.
- When the bearings fail to turn smoothly or emit noise in rotation after gear oil lubrication.
- When bearing has other defects.

2) Bushing (each gear)

Replace the bushing in following cases.

- When the sliding surface is damaged or abnormally worn.
- When the inner wall is abnormally worn.

3) Gear

Replace gears in the following cases.

- Replace the gear with new part if its tooth surfaces are broken, damaged or excessively worn.
- Correct or replace if the contact surface of the cone and baulk ring is rough or damaged.
- Correct or replace if the inner surface or end face is damaged.

4) Baulk ring

Replace the ring in following cases:

- When the inner surface and end face are damaged.
- When the ring inner surface is abnormally or partially worn down.
- When the contact surface of the synchronizer ring insert is scored or abnormally worn down.

5) Shifting insert key

Replace the insert key if deformed, excessively worn or defective in any way.

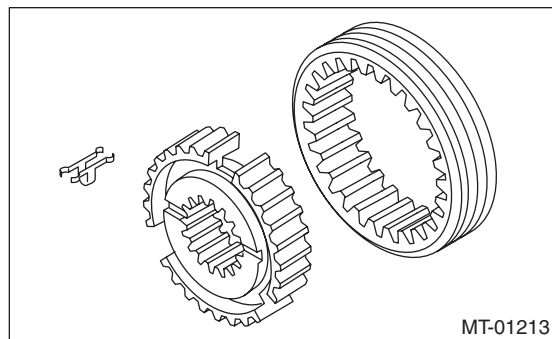

6) Oil seal

Replace the oil seal if the lip is deformed, hardened, worn or defective in any way.

7) O-ring

Replace the O-ring if the sealing face is deformed, hardened, damaged, worn or defective in any way.

8) Gearshift mechanism

Repair or replace the gearshift mechanism if excessively worn, bent or defective in any way.

F: ADJUSTMENT

Selection of main shaft rear plate:

Using the ST, measure the protrusion amount (A) of ball bearing from transmission main case surface, and select a suitable plate in the following table.

NOTE:

Before measuring, tap the end of main shaft with a plastic hammer lightly in order to make the clearance zero between the main case surface and moving flange of bearing.

ST 498147000 DEPTH GAUGE

Dimension (A) mm (in)	Part No.	Mark
4.00 — 4.13 (0.1575 — 0.1626)	32294AA041	1
3.87 — 3.99 (0.1524 — 0.1571)	32294AA051	2

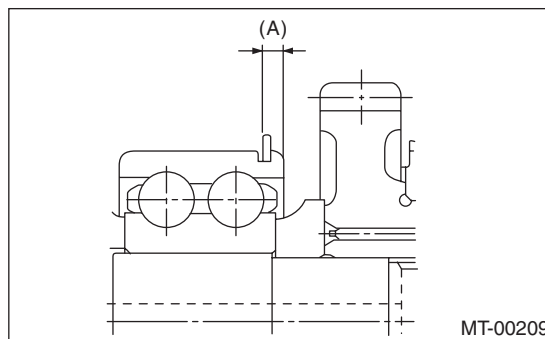

Drive Pinion Shaft Assembly

MANUAL TRANSMISSION AND DIFFERENTIAL

17. Drive Pinion Shaft Assembly

A: REMOVAL

- 1) Remove the manual transmission assembly from the vehicle. <Ref. to 5MT-25, REMOVAL, Manual Transmission Assembly.>
- 2) Remove the transfer case together with the extension case assembly. <Ref. to 5MT-39, REMOVAL, Transfer Case and Extension Case Assembly.>
- 3) Remove the transmission case. <Ref. to 5MT-51, REMOVAL, Transmission Case.>
- 4) Remove the drive pinion shaft assembly.

NOTE:

Use a hammer handle, etc. to remove if too tight.

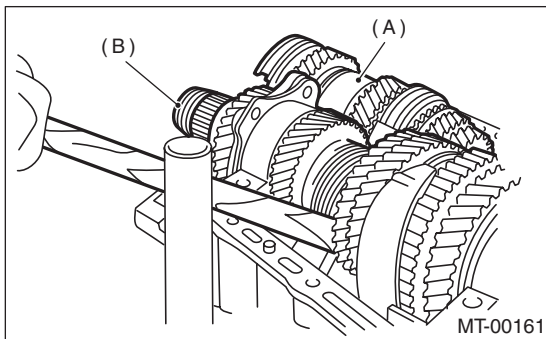

- (A) Main shaft ASSY
- (B) Drive pinion shaft ASSY

B: INSTALLATION

- 1) Remove the front differential assembly.
- 2) Alignment marks/numbers on hypoid gear set: The number (A) on top of the drive pinion, and the number on the hypoid driven gear are set numbers for the two gears. Use a pair having the same numbers. The figure (B) below shows a number for shim adjustment. If no number is shown, the value is zero.

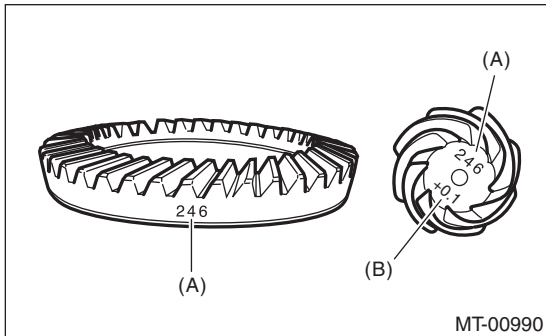

- (A) Set number
- (B) Number for shim adjustment

- 3) Place the drive pinion shaft assembly on transmission main case RH without shim and tighten the bearing mounting bolts.

- 4) Perform inspection and adjustment of ST.

NOTE:

- Loosen the two bolts and adjust so that the scale indicates 0.5 correctly when the plate end and the scale end are on the same level.
- Tighten the two bolts.

ST 499917500 DRIVE PINION GAUGE ASSY

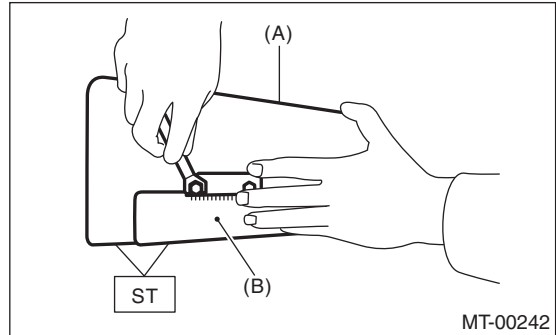

- (A) Plate
- (B) Scale

- 5) Position the ST by inserting the knock pin of ST into the knock hole of transmission case.

ST 499917500 DRIVE PINION GAUGE ASSY

- 6) Slide the drive pinion gauge scale with finger tip and read the value at the point where it matches with the end face of drive pinion.

ST 499917500 DRIVE PINION GAUGE ASSY

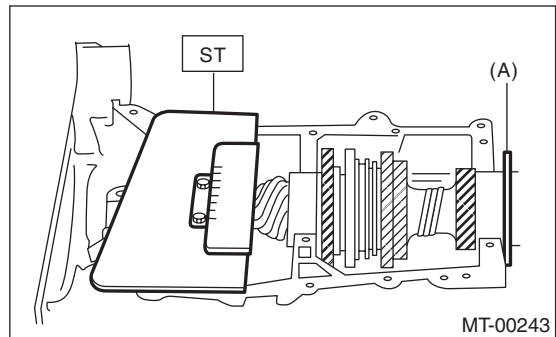

- (A) Adjust the clearance to zero without shim.

- 7) The thickness of shim shall be determined by adding the value indicated on drive pinion to the value indicated on the ST. (Add if the number on drive pinion is prefixed by +, and subtract if the number is prefixed by -.)

ST 499917500 DRIVE PINION GAUGE ASSY

Drive Pinion Shaft Assembly

MANUAL TRANSMISSION AND DIFFERENTIAL

8) Select one to three shims in the following table for the value determined as described above, and take the shim(s) which thickness is closest to the said value.

Drive pinion shim	
Part No.	Thickness mm (in)
32295AA031	0.150 (0.0059)
32295AA041	0.175 (0.0069)
32295AA051	0.200 (0.0079)
32295AA061	0.225 (0.0089)
32295AA071	0.250 (0.0098)
32295AA081	0.275 (0.0108)
32295AA091	0.300 (0.0118)
32295AA101	0.500 (0.0197)

9) Install the front differential assembly. <Ref. to 5MT-68, INSTALLATION, Front Differential Assembly.>

10) Set the transmission main shaft assembly and drive pinion shaft assembly in position. (When doing so, there will be no clearance between the two when moved all the way to the front). Inspect a suitable 1st-2nd, 3rd-4th and 5th shifter fork so that the coupling sleeve and reverse driven gear are positioned in the center of the synchronizing mechanism. <Ref. to 5MT-65, INSPECTION, Drive Pinion Shaft Assembly.>

11) Install the transmission case. <Ref. to 5MT-51, INSTALLATION, Transmission Case.>

12) Install the transfer case together with the extension case assembly. <Ref. to 5MT-39, INSTALLATION, Transfer Case and Extension Case Assembly.>

13) Install the manual transmission assembly to the vehicle. <Ref. to 5MT-28, INSTALLATION, Manual Transmission Assembly.>

C: DISASSEMBLY

NOTE:

Attach a cloth to the end of driven shaft (on the frictional side of the thrust needle bearing) to prevent damage during disassembly or reassembly.

1) Flatten the nut tab. Remove the lock nut with ST1, ST2 and ST3.

ST1 899884100 HOLDER

ST2 498427100 STOPPER

ST3 899988608 SOCKET WRENCH (27)

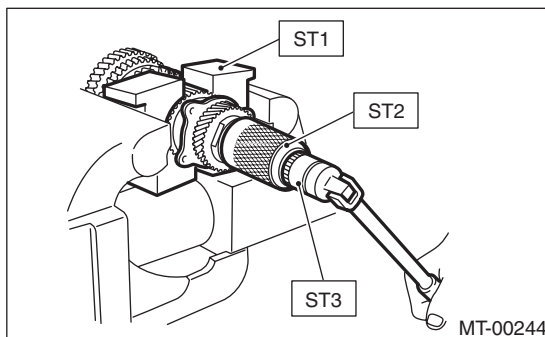

2) Draw out the drive pinion from driven shaft. Remove the differential bevel gear sleeve, adjusting washer No. 1, adjusting washer No. 2, thrust bearing, needle bearing and drive pinion collar.

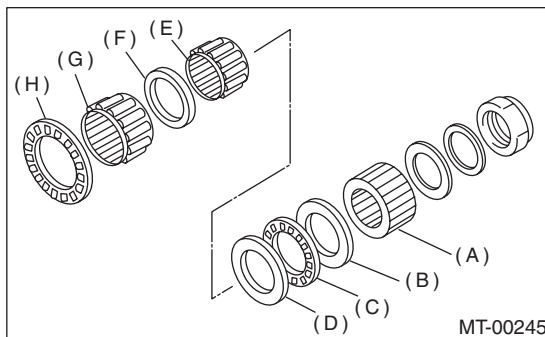

- (A) Differential bevel gear sleeve
- (B) Adjusting washer No. 1 (25 × 37.5 × t)
- (C) Thrust bearing (25 × 37.5 × 3)
- (D) Adjusting washer No. 2 (25 × 37.5 × 4)
- (E) Needle bearing (25 × 30 × 20)
- (F) Drive pinion collar
- (G) Needle bearing (30 × 37 × 23)
- (H) Thrust bearing (33 × 50 × 3)

Drive Pinion Shaft Assembly

MANUAL TRANSMISSION AND DIFFERENTIAL

3) Remove the roller bearing and washer using ST and a press.

NOTE:

Do not reuse the roller bearing.
ST 498077000 REMOVER

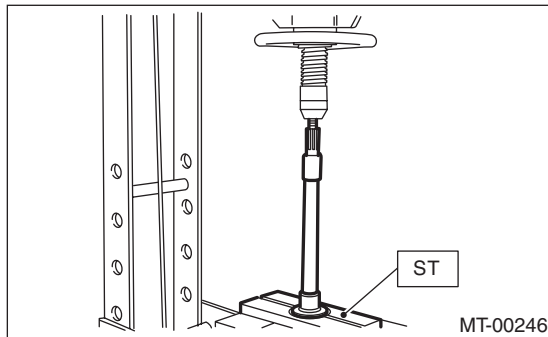

4) Flatten the nut tab. Remove the lock nut using ST1 and ST2.

ST1 499987300 SOCKET WRENCH (50)
ST2 899884100 HOLDER

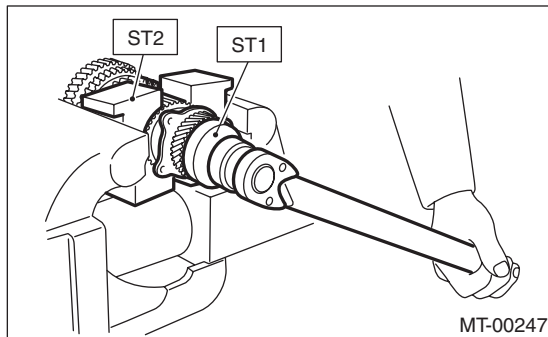

5) Remove the 5th driven gear using ST.

ST 499857000 5TH DRIVEN GEAR REMOVER

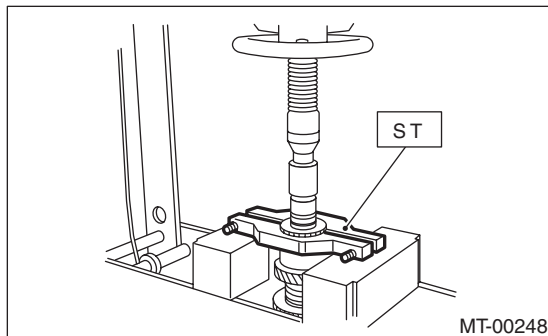

6) Remove the woodruff key.

7) Remove the roller bearing, and 3rd-4th driven gear using ST1 and ST2.

ST1 499757002 INSTALLER
ST2 899714110 REMOVER

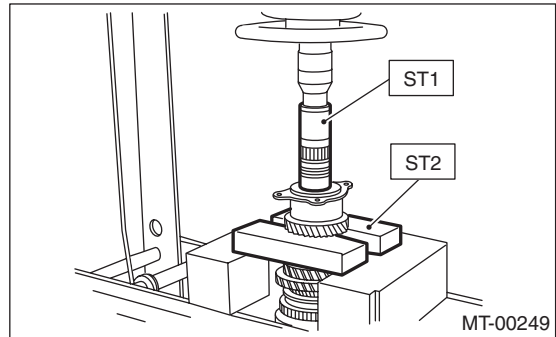

8) Remove the key.

9) Remove the 2nd driven gear, inner baulk ring, synchro cone and outer baulk ring.

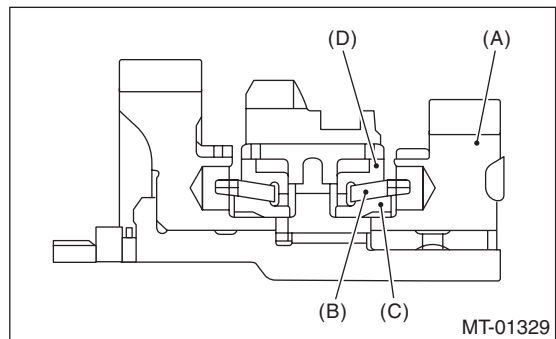

(A) 2nd driven gear

(B) Inner baulk ring

(C) Synchro cone

(D) Outer baulk ring

10) Remove the 1st driven gear, inner baulk ring, synchro cone, outer baulk ring, 2nd gear bushing, gear & hub using ST1 and ST2.

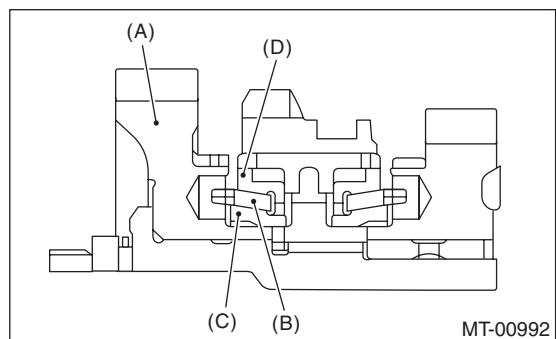

(A) 1st driven gear

(B) Inner baulk ring

(C) Synchro cone

(D) Outer baulk ring

Drive Pinion Shaft Assembly

MANUAL TRANSMISSION AND DIFFERENTIAL

NOTE:

If necessary, use the new gear & hub assembly, when replacing the gear or hub assembly. Because these must engage at the specified point, avoid disassembly as much as possible. If it must be disassembled, mark the engaging point on the spline beforehand.

ST1 499757002 INSTALLER

ST2 899714110 REMOVER

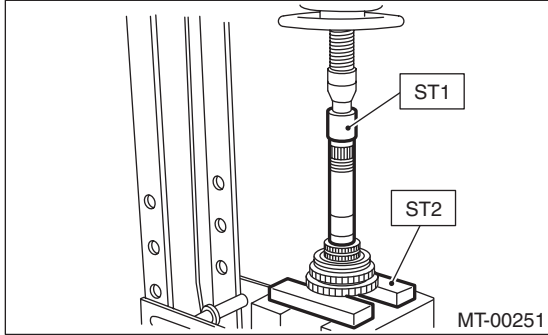

11) Remove the sub gear, washer, and snap ring (outer) for the 1st driven gear. (Non-turbo model)

D: ASSEMBLY

1) Install the sleeve and gear & hub assembly by matching alignment marks.

NOTE:

Use the new gear & hub assembly, if replacing the gear or hub.

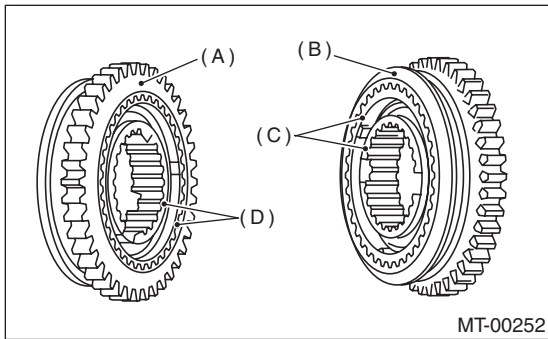

- (A) 1st gear side
- (B) 2nd gear side
- (C) Flush surface
- (D) Stepped surface

2) Install the washer, snap ring (outer) and sub gear onto the 1st driven gear. (Non-turbo model)

3) Install the 1st driven gear, inner baulk ring, synchro cone, outer baulk ring, gear & hub assembly onto driven shaft. (Turbo model)

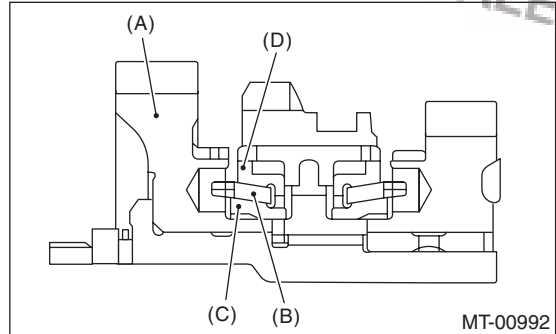

- (A) 1st driven gear
- (B) Inner baulk ring
- (C) Synchro cone
- (D) Outer baulk ring

NOTE:

- Take care to install the gear & hub assembly in proper direction.
- Align the baulk ring and gear & hub assembly with the key groove.

4) Install the 2nd driven gear bushing onto the driven shaft using ST1, ST2 and a press.

CAUTION:

Do not apply a load in excess of 10 kN (1 ton, 1.1 US ton, 1.0 Imp ton).

NOTE:

- Attach a cloth to the end of the driven shaft to prevent damage.
- When press fitting, align the oil holes of the shaft and bushing

ST1 499277200 INSTALLER

ST2 499587000 INSTALLER

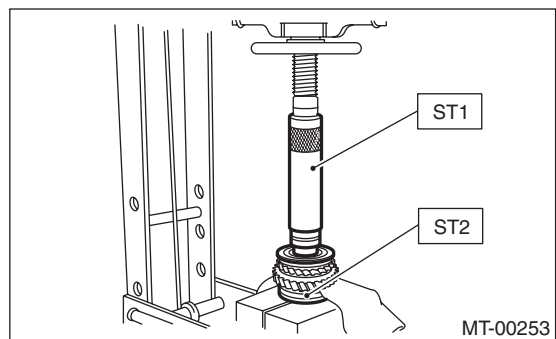

Drive Pinion Shaft Assembly

MANUAL TRANSMISSION AND DIFFERENTIAL

5) Install the 2nd driven gear, inner baulk ring, synchro cone and outer baulk ring, and insert them onto driven shaft.

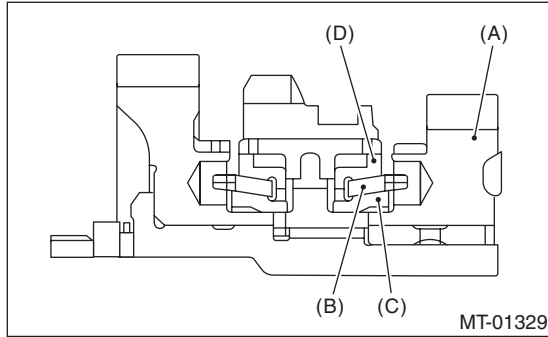

- (A) 2nd driven gear
- (B) Inner baulk ring
- (C) Synchro cone
- (D) Outer baulk ring

6) After installing key on driven shaft, install the 3rd-4th driven gear using an ST and a press.

CAUTION:

Do not apply a load in excess of 10 kN (1 ton, 1.1 US ton, 1.0 Imp ton).

NOTE:

Align the groove in baulk ring with the insert.

ST 499277200 INSTALLER

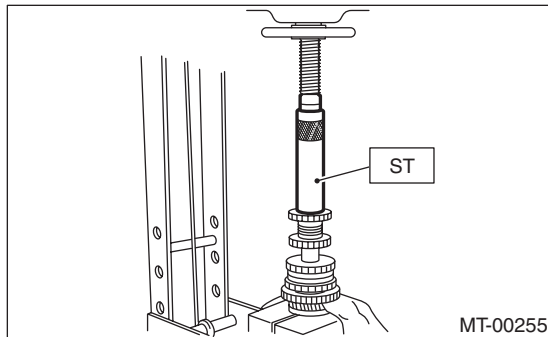

7) Install a set of roller bearings onto the driven shaft using the ST and a press.

CAUTION:

Do not apply a load in excess of 10 kN (1 ton, 1.1 US ton, 1.0 Imp ton).

ST 499277200 INSTALLER

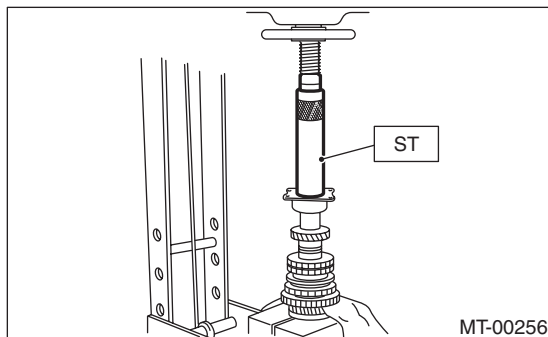

8) Position the woodruff key in groove of the rear of driven shaft. Install the 5th driven gear onto driven shaft using ST and a press.

CAUTION:

Do not apply a load in excess of 10 kN (1 ton, 1.1 US ton, 1.0 Imp ton).

ST 499277200 INSTALLER

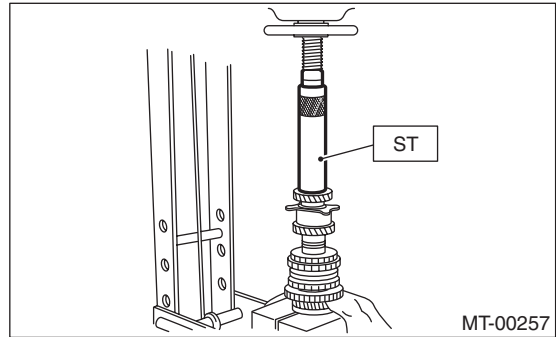

9) Install the lock washer. Install the lock nut and tighten to the specified torque using the ST.

ST 499987300 SOCKET WRENCH (50)

Tightening torque:

260 N·m (26.5 kgf·m, 191.7 ft·lb)

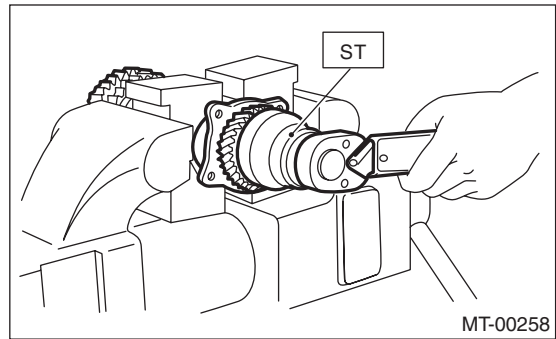

NOTE:

- Crimp the locknut in 2 locations.
- Using a spring scale, check that starting torque of roller bearing is 0.1 to 1.5 N (0.01 to 0.15 kgf, 0.02 to 0.33 lbf).

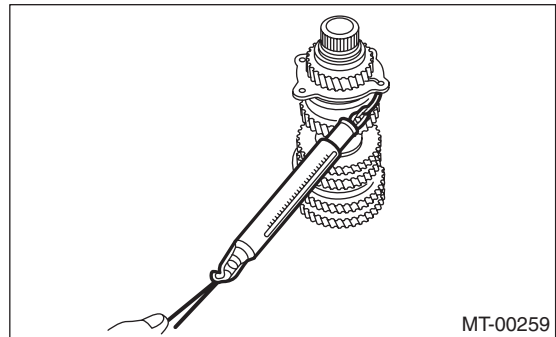

Drive Pinion Shaft Assembly

MANUAL TRANSMISSION AND DIFFERENTIAL

10) Install the roller bearing onto drive pinion.

NOTE:

When installing the roller bearing, note its directions (front and rear) because the knock pin hole of outer race is offset.

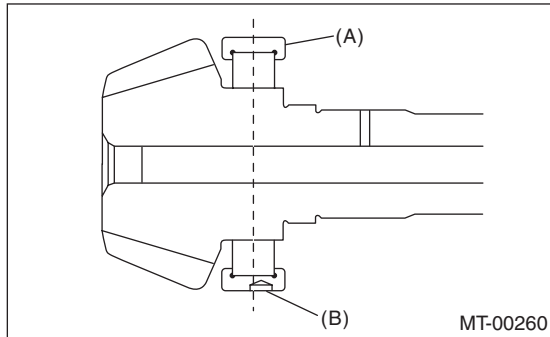

- (A) Roller bearing
- (B) Knock pin hole

11) Install the washer using ST1, ST2 and a press.

CAUTION:

Do not apply a load in excess of 10 kN (1 ton, 1.1 US ton, 1.0 Imp ton).

ST1 499277100 BUSHING 1-2 INSTALLER

ST2 499277200 INSTALLER

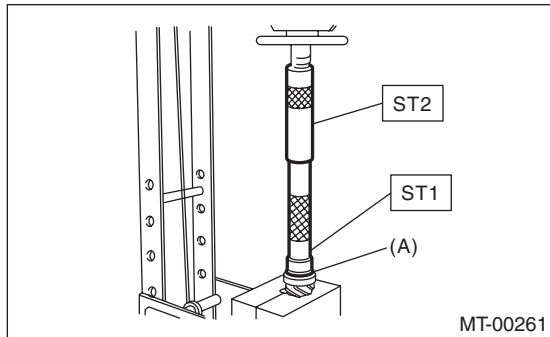

- (A) Washer

12) Install the thrust bearing and needle bearing. Install the driven shaft assembly.

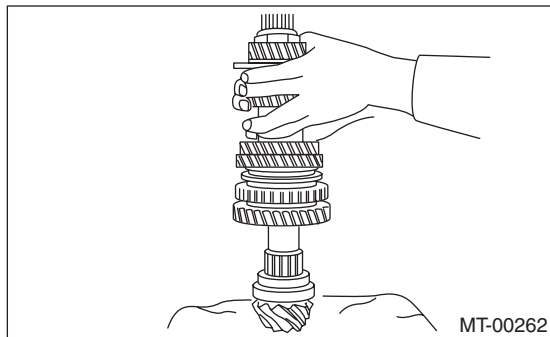

13) Install the drive pinion collar, needle bearing, adjusting washer No. 2, thrust bearing, adjusting washer No. 1 and differential bevel gear sleeve in this order.

NOTE:

Be careful to install the spacer in the proper direction.

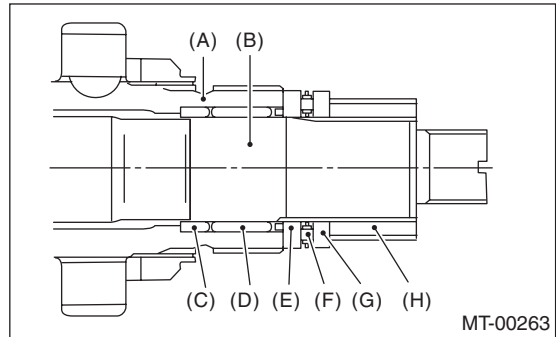

- (A) Driven shaft
- (B) Drive shaft
- (C) Drive pinion collar
- (D) Needle bearing (25 × 30 × 20)
- (E) Adjusting washer No. 2 (25 × 36 × 4)
- (F) Thrust bearing (25 × 37.5 × 3)
- (G) Adjusting washer No. 1 (25 × 36 × t)
- (H) Differential bevel gear sleeve

14) Adjust the thrust bearing preload. <Ref. to 5MT-66, THRUST BEARING PRELOAD, ADJUSTMENT, Drive Pinion Shaft Assembly.>

Drive Pinion Shaft Assembly

MANUAL TRANSMISSION AND DIFFERENTIAL

E: INSPECTION

Disassembled parts should be washed clean first with cleaning solvent and then inspected carefully.

1) Bearing

Replace the bearings in the following cases.

- When the bearing balls, outer races and inner races are broken or rusty.
- When the bearing is worn.
- When the bearings fail to turn smoothly or emit noise in rotation after gear oil lubrication.
- The ball bearing on the rear side of the drive pinion shaft should be checked for smooth rotation before the drive pinion shaft assembly is disassembled. In this case, because a preload is working on the bearing, its rotation feels like it is slightly dragging unlike other bearings.

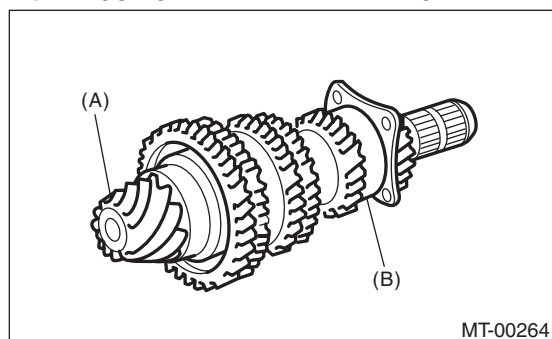

(A) Drive pinion shaft

(B) Ball bearing

- When bearing has other defects.

2) Bushing (each gear)

Replace the bushing in following cases.

- When the sliding surface is damaged or abnormally worn.
- When the inner wall is abnormally worn.

3) Gear

Replace gears in the following cases.

- Replace the gear with new part if its tooth surfaces are broken, damaged or excessively worn.
- Correct or replace if the contact surface of the cone and baulk ring is rough or damaged.
- Repair or replace if the inner surface or end face are damaged.

4) Baulk ring

Replace the ring in following cases:

- When the inner surface and end face are damaged.
- When the ring inner surface is abnormally or partially worn down.
- If the gap between the end faces of the ring and the gear splined part is excessively small, check the clearance (A) while pressing the ring against the cone.

Clearance (A):

0.5 — 1.0 mm (0.020 — 0.040 in)

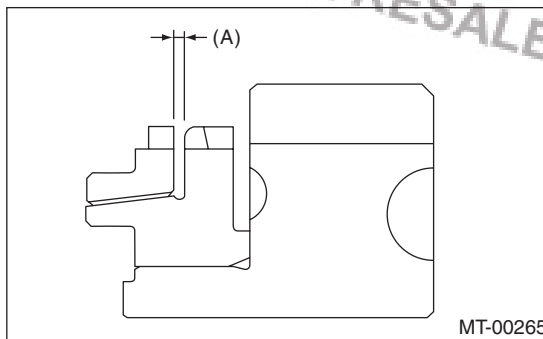

- When the contact surface of the synchronizer ring insert is scratched or abnormally worn.

5) Shifting insert key

Replace the insert key if deformed, excessively worn or defective in any way.

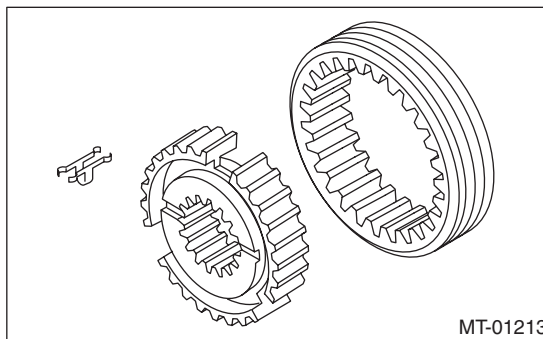

6) Oil seal

Replace the oil seal if the lip is deformed, hardened, worn or defective in any way.

7) O-ring

Replace the O-ring if the sealing face is deformed, hardened, damaged, worn or defective in any way.

Drive Pinion Shaft Assembly

MANUAL TRANSMISSION AND DIFFERENTIAL

F: ADJUSTMENT

1. THRUST BEARING PRELOAD

1) Select a suitable adjusting washer No. 1 to so that dimension (H) will be zero in a visual check. Position the washer (18.3 × 30 × 4) and lock washer (18 × 30 × 2) and attach the lock nut. (18 × 13.5)

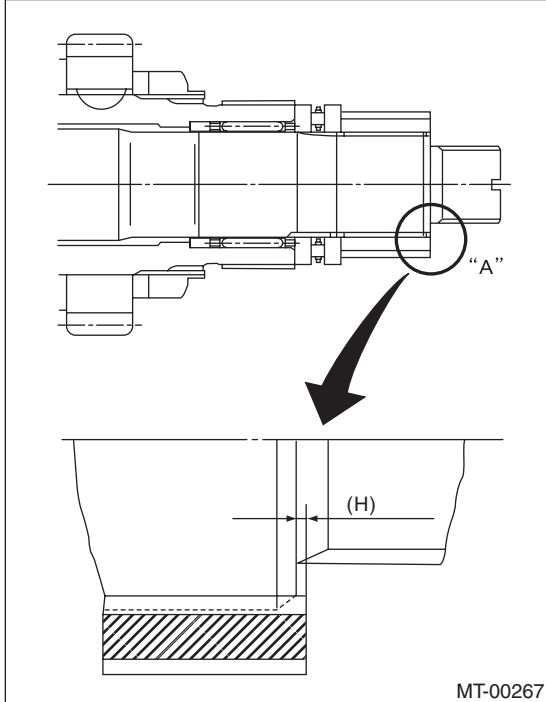

2) Using the ST1, ST2 and ST3, tighten the new lock nut to the specified torque.

ST1 899884100 HOLDER
 ST2 498427100 STOPPER
 ST3 899988608 SOCKET WRENCH (27)

Tightening torque:

120 N·m (12.2 kgf·m, 88.5 ft·lb)

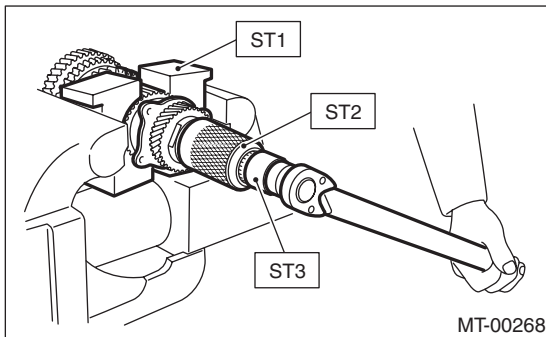

3) After removing the ST2, measure the starting torque using torque driver.

ST1 899884100 HOLDER

ST3 899988608 SOCKET WRENCH (27)

Starting torque:

0.3 — 0.8 N·m

(0.03 — 0.08 kgf·m, 0.2 — 0.6 ft·lb)

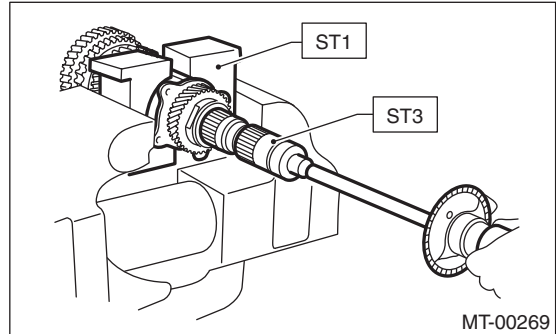

4) If the starting torque is not within the specified limit, select new adjusting washer No. 1 and re-check starting torque.

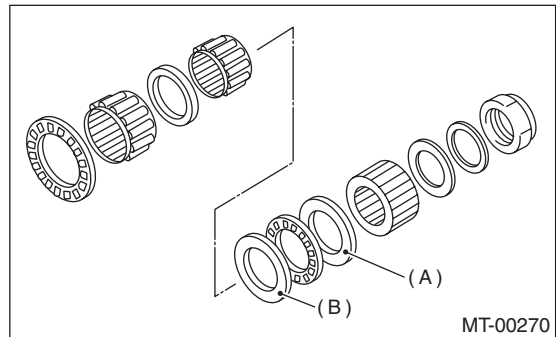

(A) Adjusting washer No. 1

(B) Adjusting washer No. 2

Adjusting washer No. 1	
Part No.	Thickness mm (in)
803025051	3.925 (0.1545)
803025052	3.950 (0.1555)
803025053	3.975 (0.1565)
803025054	4.000 (0.1575)
803025055	4.025 (0.1585)
803025056	4.050 (0.1594)
803025057	4.075 (0.1604)

Drive Pinion Shaft Assembly

MANUAL TRANSMISSION AND DIFFERENTIAL

5) When the specified starting torque cannot be obtained by adjusting washer No. 1, select adjusting washer No. 2 from the following table. Repeat steps 1) through 4) to adjust starting torque.

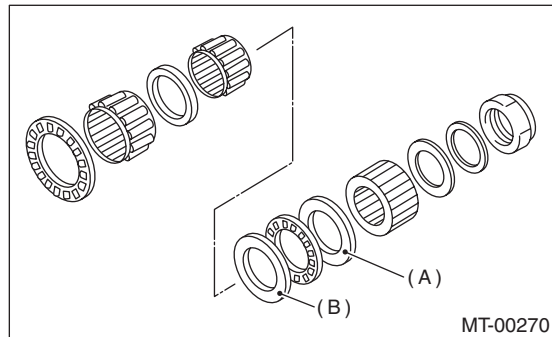

- (A) Adjusting washer No. 1
- (B) Adjusting washer No. 2

Starting torque	Dimension H	Adjusting washer No. 2
Low	Small	Select thicker one.
High	Large	Select thinner one.

Adjusting washer No. 2	
Part No.	Thickness mm (in)
803025059	3.850 (0.1516)
803025054	4.000 (0.1575)
803025058	4.150 (0.1634)

6) Recheck that the starting torque is within the specified range, then crimp the lock nut at four positions.

Front Differential Assembly

MANUAL TRANSMISSION AND DIFFERENTIAL

18. Front Differential Assembly

A: REMOVAL

- 1) Remove the manual transmission assembly from the vehicle. <Ref. to 5MT-25, REMOVAL, Manual Transmission Assembly.>
- 2) Remove the transfer case together with the extension case assembly. <Ref. to 5MT-39, REMOVAL, Transfer Case and Extension Case Assembly.>
- 3) Remove the transmission case. <Ref. to 5MT-51, REMOVAL, Transmission Case.>
- 4) Remove the drive pinion shaft assembly. <Ref. to 5MT-59, REMOVAL, Drive Pinion Shaft Assembly.>
- 5) Remove the main shaft assembly. <Ref. to 5MT-54, REMOVAL, Main Shaft Assembly.>
- 6) Remove the front differential assembly.

NOTE:

- Do not confuse the right and left roller bearing outer races.
- Be careful not to damage the oil seal of retainer.

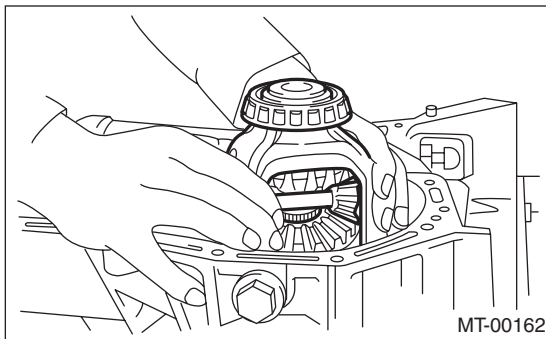

- 7) Remove the differential side retainers using ST. ST 18630AA010 WRENCH COMPL RETAINER

NOTE:

ST 499787000 WRENCH ASSEMBLY can also be used.

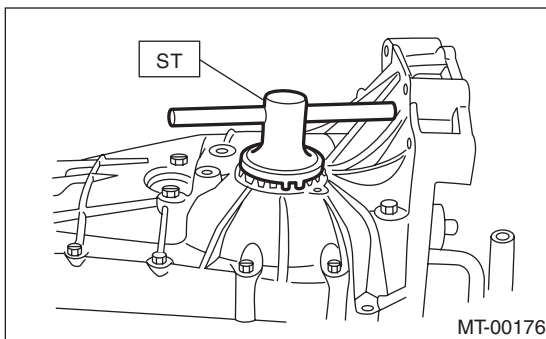

- 8) Remove the bearing outer race from the transmission case.

ST 398527700 PULLER ASSY

B: INSTALLATION

- 1) Install the differential side retainers using ST. ST 18630AA010 WRENCH COMPL RETAINER
- 2) Install the bearing outer race to the transmission case.
- 3) Install the front differential assembly.

NOTE:

Be careful not to fold the sealing lip of oil seal.

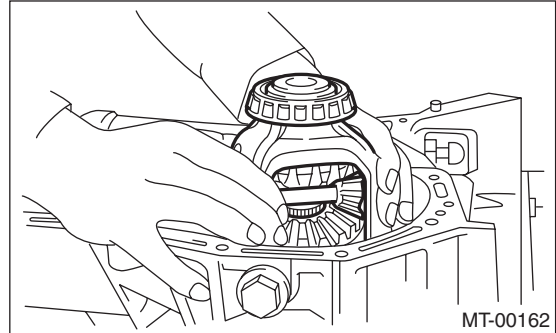

- 4) Install the main shaft assembly. <Ref. to 5MT-54, INSTALLATION, Main Shaft Assembly.>
- 5) Install the drive pinion shaft assembly. <Ref. to 5MT-59, INSTALLATION, Drive Pinion Shaft Assembly.>
- 6) Install the transmission case. <Ref. to 5MT-51, INSTALLATION, Transmission Case.>
- 7) Install the transfer case together with the extension case assembly. <Ref. to 5MT-39, INSTALLATION, Transfer Case and Extension Case Assembly.>
- 8) Install the manual transmission assembly to the vehicle. <Ref. to 5MT-28, INSTALLATION, Manual Transmission Assembly.>

Front Differential Assembly

MANUAL TRANSMISSION AND DIFFERENTIAL

C: DISASSEMBLY

1. DIFFERENTIAL CASE ASSEMBLY

1) Loosen the twelve bolts and remove hypoid driven gear.

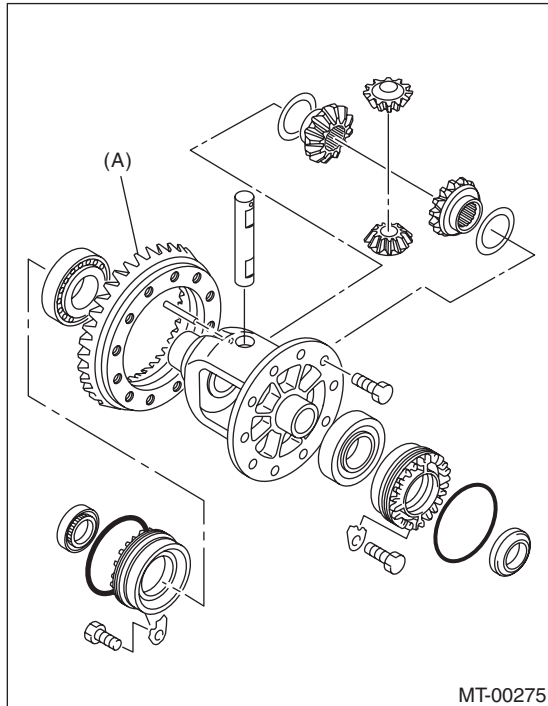

(A) Hypoid driven gear

2) Drive out the straight pin from differential assembly toward hypoid driven gear side.

ST 899904100 STRAIGHT PIN REMOVER

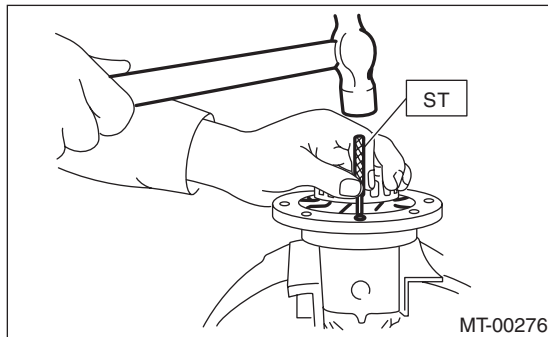

3) Pull out the pinion shaft, and remove the differential bevel pinion, differential bevel gear and washer.

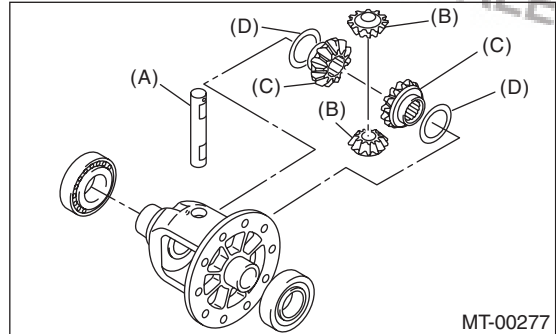

- (A) Pinion shaft
- (B) Differential bevel pinion
- (C) Differential bevel gear
- (D) Washer

4) Using the ST, remove the roller bearing.

ST 899524100 PULLER SET

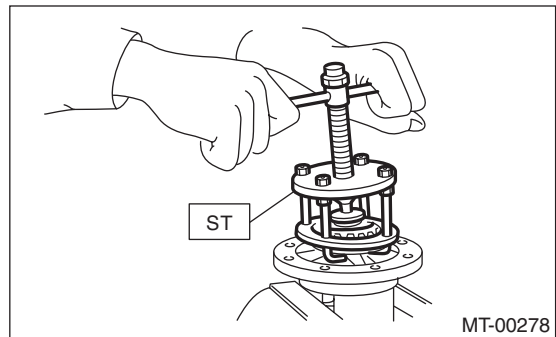

2. SIDE RETAINER

1) Remove the O-ring.

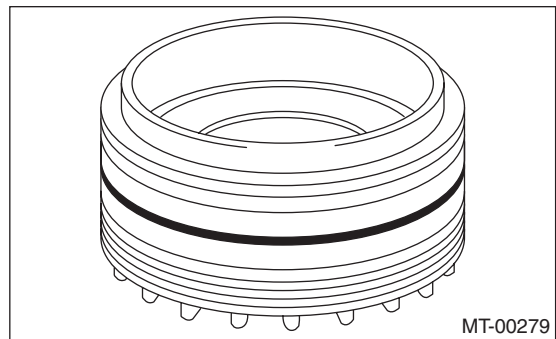

Front Differential Assembly

MANUAL TRANSMISSION AND DIFFERENTIAL

2) Remove the oil seal.

NOTE:

- Remove using the flat tip screwdriver.
- Do not reuse the oil seal. Replace the oil seal with a new part.

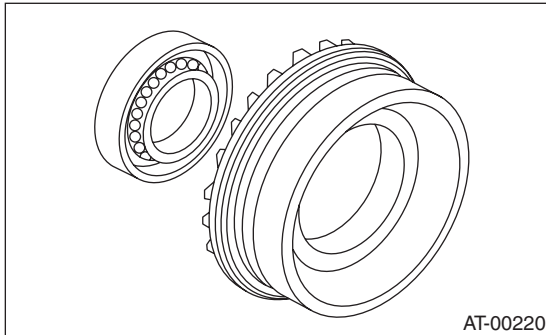

D: ASSEMBLY

1. DIFFERENTIAL CASE ASSEMBLY

1) Install the differential bevel gear and differential bevel pinion together with washers, and insert the pinion shaft.

NOTE:

Face the chamfered side of washer toward gear.

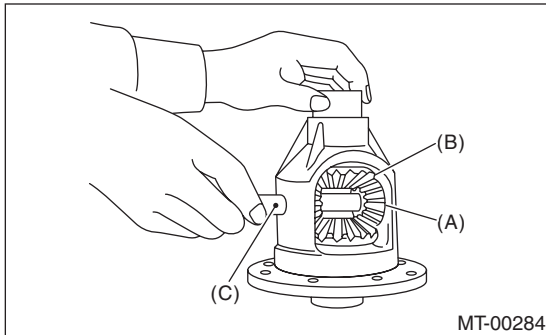

- (A) Differential bevel pinion
- (B) Differential bevel gear
- (C) Pinion shaft

2) Measure the backlash between differential bevel gear and differential pinion. If backlash is not within specified value, install a suitable washer to adjust. <Ref. to 5MT-72, ADJUSTMENT, Front Differential Assembly.>

NOTE:

Be sure the pinion gear teeth contacts adjacent gear teeth during measurement.

- ST1 498247001 MAGNET BASE
- ST2 498247100 DIAL GAUGE

Standard backlash

0.13 — 0.18 mm (0.0051 — 0.0071 in)

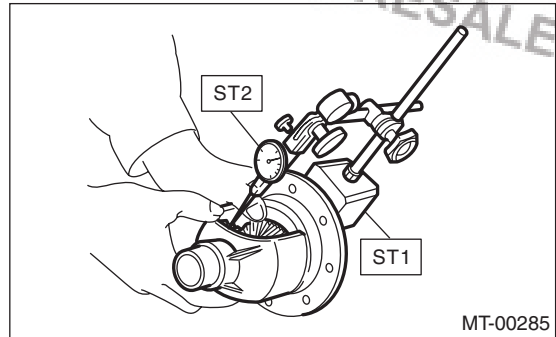

3) Align the pinion shaft and differential case with each hole, and drive the straight pin into the holes from the hypoid driven gear using the ST.

NOTE:

Lock the straight pin after installing.

ST 899904100 STRAIGHT PIN REMOVER

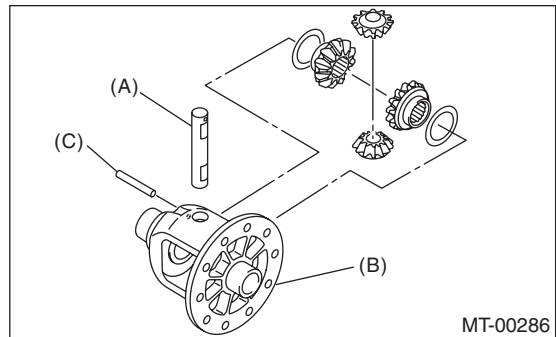

- (A) Pinion shaft
- (B) Differential case
- (C) Straight pin

4) Install the roller bearing to differential case.

CAUTION:

Do not apply a load in excess of 10 kN (1 ton, 1.1 US ton, 1.0 Imp ton).

NOTE:

Be careful because the roller bearing outer races are used as a set.

- ST1 499277100 BUSHING 1-2 INSTALLER
- ST2 398497701 ADAPTER

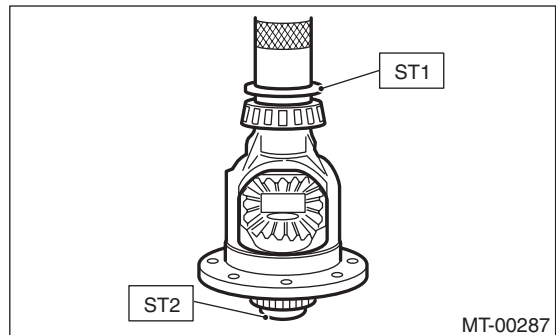

Front Differential Assembly

MANUAL TRANSMISSION AND DIFFERENTIAL

5) Install the hypoid driven gear to the differential case using twelve bolts.

Tightening torque:

T: 62 N·m (6.3 kgf·m, 45.6 ft·lb)

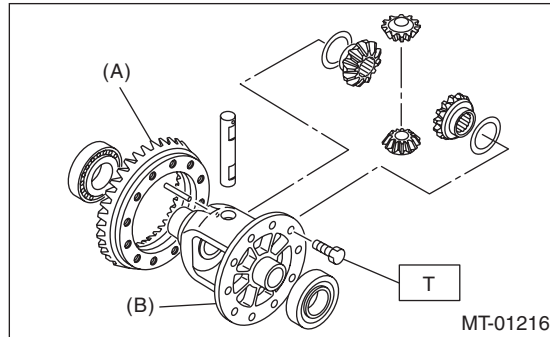

- (A) Hypoid driven gear
- (B) Differential case

2. SIDE RETAINER

1) Install a new oil seal.

ST 18675AA000 DIFFERENTIAL SIDE OIL SEAL INSTALLER

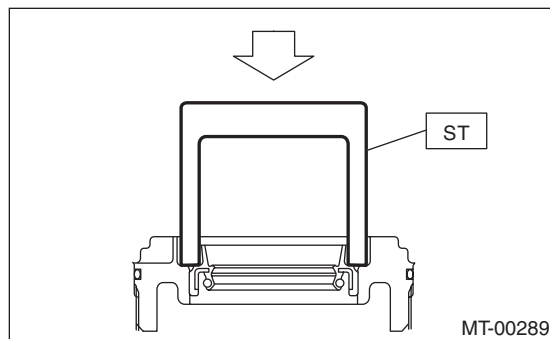

CAUTION:

- When press-fitting the oil seal to the side retainer, tap with a plastic hammer etc. to press in.

- Never use a press.

2) Install a new O-ring.

NOTE:

Do not stretch or damage the O-ring.

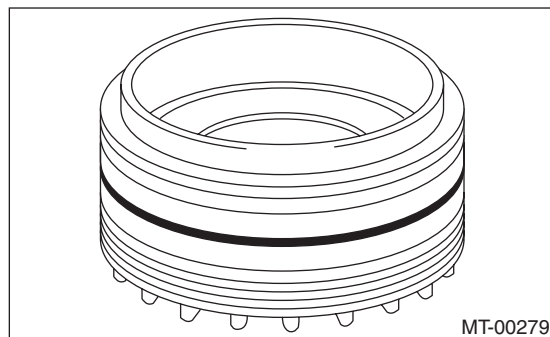

E: INSPECTION

Repair or replace the differential gear in the following cases:

- If the hypoid drive gear and drive pinion shaft tooth surfaces are damaged, excessively worn, or seized.
- When the roller bearing on the drive pinion shaft has a worn or damaged roller path.
- When there is damage, wear or seizure of the differential bevel pinion, differential bevel gear, washer, pinion shaft or straight pin.
- When the differential case sliding surfaces are worn or damaged.

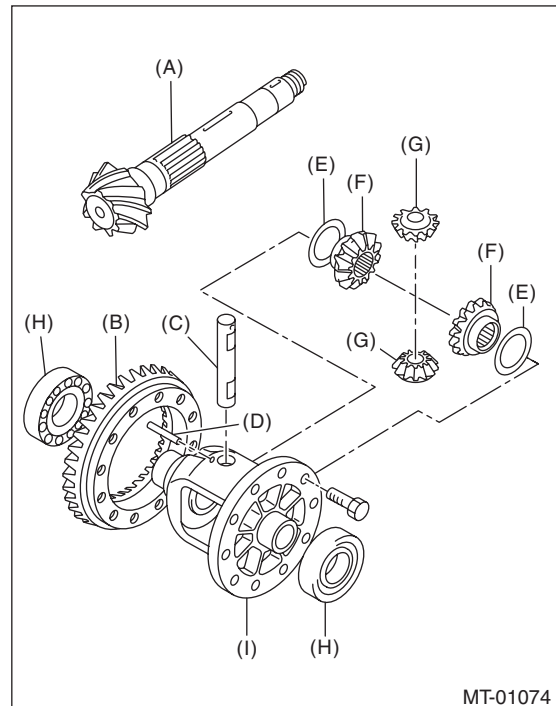

- (A) Drive pinion shaft
- (B) Hypoid driven gear
- (C) Pinion shaft
- (D) Straight pin
- (E) Washer
- (F) Differential bevel gear
- (G) Differential bevel pinion
- (H) Roller bearing
- (I) Differential case

Front Differential Assembly

MANUAL TRANSMISSION AND DIFFERENTIAL

1. BEVEL PINION GEAR BACKLASH

Measure the backlash between differential bevel gear and differential bevel pinion. If backlash is not within specified value, install a suitable washer to adjust.

NOTE:

Be sure the pinion gear teeth contacts adjacent gear teeth during measurement.

ST1 498247001 MAGNET BASE
ST2 498247100 DIAL GAUGE

Standard backlash

0.13 — 0.18 mm (0.0051 — 0.0071 in)

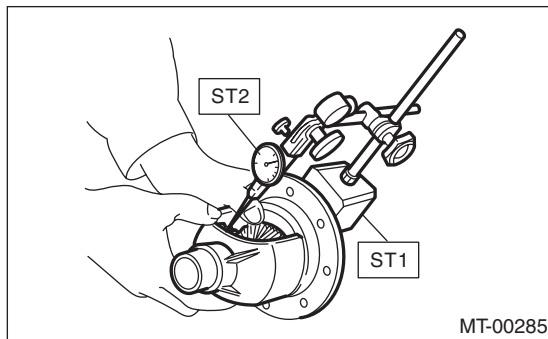

2. HYPOID GEAR BACKLASH

1) Set the ST1, ST2 and ST3. Insert the needle through transmission oil drain plug hole so that the needle comes in contact with the tooth surface on the right corner, and check the backlash.

ST1 498247001 MAGNET BASE
ST2 498247100 DIAL GAUGE
ST3 498255400 PLATE

2) Install SUBARU genuine axle shafts to both sides, rotate in the inversion direction so that the gauge contacts the tooth surface, and read the dial gauge

Part No. 38415AA100AXLE SHAFT

Backlash:

0.13 — 0.18 mm (0.0051 — 0.0071 in)

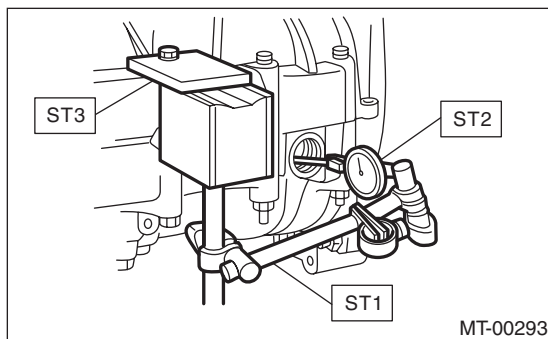

NOTE:

If the backlash is outside the specified range, adjust it by turning the holder in the RH side case.

3. TOOTH CONTACT OF HYPOID GEAR

Check tooth contact of hypoid gear as follows: Apply a thin uniform coat of red lead on both teeth surfaces on 3 or 4 teeth of the hypoid gear. Move the hypoid gear back and forth by turning the transmission main shaft until a definite contact pattern is developed on the hypoid gear, and judge whether face contact is correct. If it is improper, make adjustment. <Ref. to 5MT-72, ADJUSTMENT, Front Differential Assembly.>

- Tooth contact is correct.

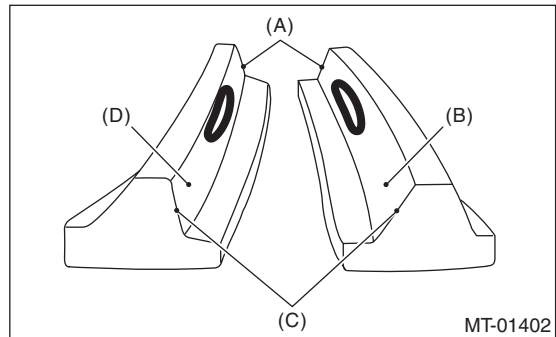

- (A) Toe
- (B) Coast side
- (C) Heel
- (D) Drive side

F: ADJUSTMENT

1. BEVEL PINION GEAR BACKLASH

1) Disassemble the front differential assembly. <Ref. to 5MT-69, DISASSEMBLY, Front Differential Assembly.>

2) Select a different washer from the table and install.

Washer	
Part No.	Thickness mm (in)
803038021	0.925 — 0.950 (0.0364 — 0.0374)
803038022	0.975 — 1.000 (0.0384 — 0.0394)
803038023	1.025 — 1.050 (0.0404 — 0.0413)

3) Adjust until the standard value is obtained.

Standard backlash

0.13 — 0.18 mm (0.0051 — 0.0071 in)

Front Differential Assembly

MANUAL TRANSMISSION AND DIFFERENTIAL

2. HYPOID GEAR BACKLASH

Adjust the backlash by turning the holder in the RH side case.

ST 18630AA010 WRENCH COMPL RETAINER

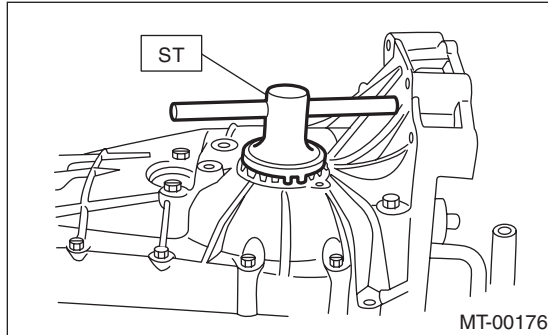

NOTE:

Each time side retainer rotates one tooth, backlash changes by 0.05 mm (0.020 in).

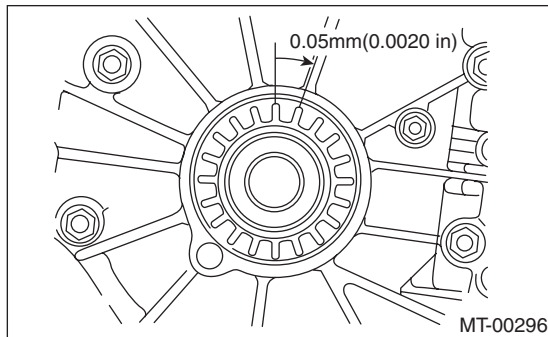

3. TOOTH CONTACT OF HYPOID GEAR

- 1) Adjust until correct teeth contact is obtained.
- 2) Check tooth contact, and perform the adjustment as follows.

- Tooth contact

Check item: Tooth contact surface is slightly shifted toward the toe side under a no-load condition. (When driving, it moves towards the heel side.)

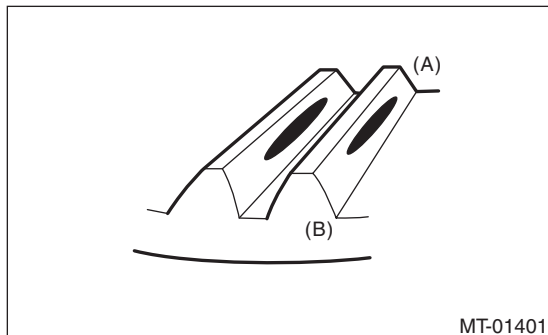

- (A) Toe side
- (B) Heel side

- Face contact

Check item: Backlash is too large.

Contact pattern

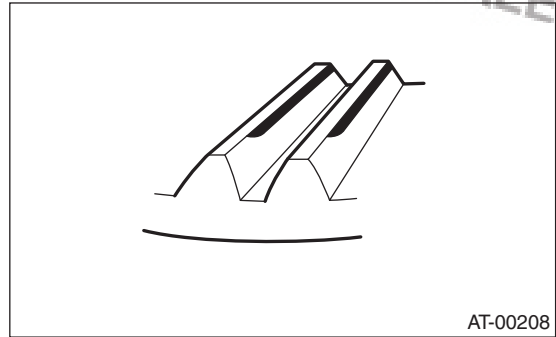

Corrective action: Reduce thickness of pinion height adjusting washer in order to bring the drive pinion closer to driven gear side.

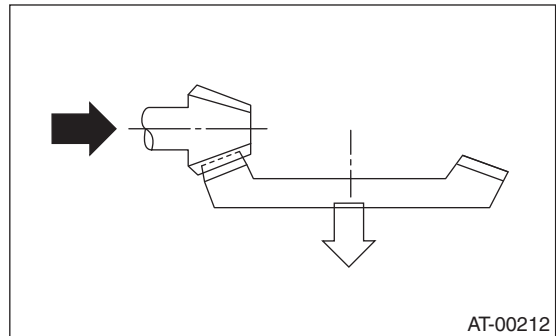

- Flank contact

Check item: Backlash is too small.

Contact pattern

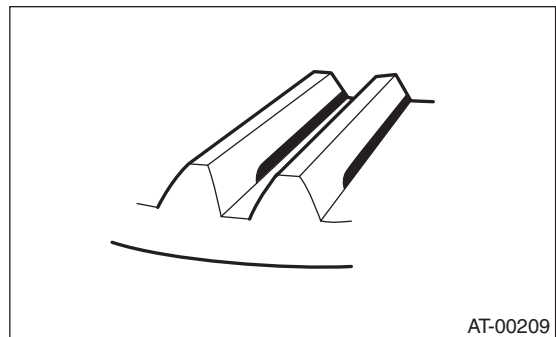

Corrective action: Increase the thickness of the pinion height adjusting washer in order to place the drive pinion away from the driven gear.

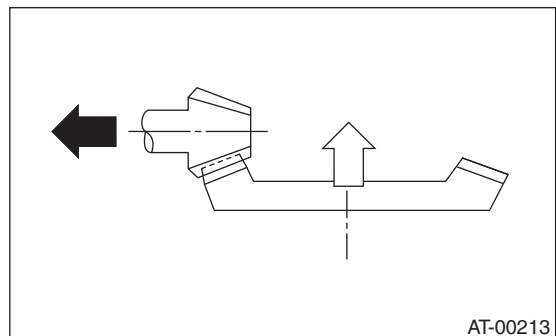

Front Differential Assembly

MANUAL TRANSMISSION AND DIFFERENTIAL

- Toe contact (inside contact)

Check item: Teeth contact area is too small.

Contact pattern

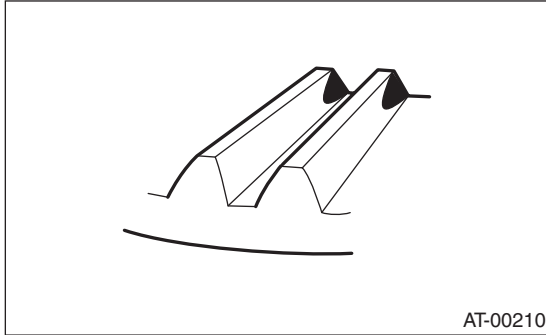

Corrective action: Increase thickness of pinion height adjusting washer according to the procedures for moving the drive pinion closer to the driven gear.

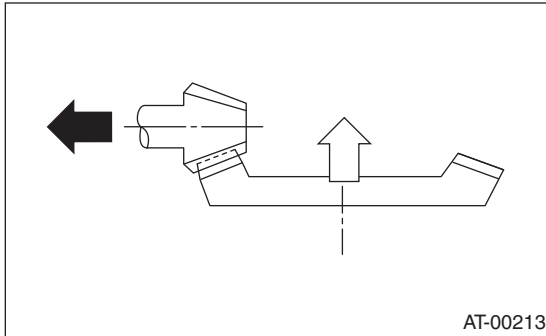

- Heel contact (outside end contact)

Check item: Teeth contact area is too small.

Contact pattern

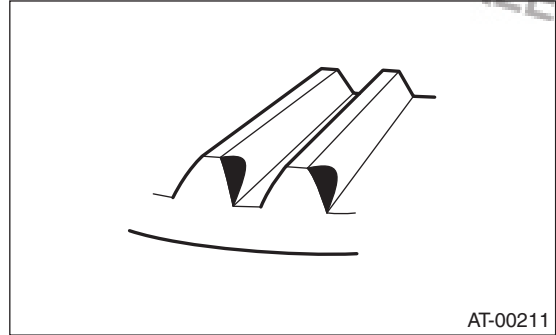

Corrective action: Reduce thickness of the pinion height adjusting washer according to the procedures for moving the drive pinion away from the driven gear.

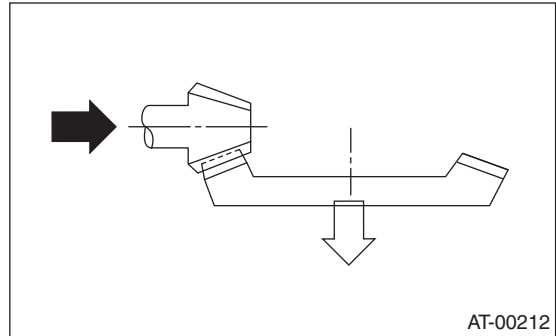

19.Speedometer Gear

A: REMOVAL

- 1) Remove the manual transmission assembly from the vehicle. <Ref. to 5MT-25, REMOVAL, Manual Transmission Assembly.>
- 2) Remove the back-up light switch and the neutral position switch. <Ref. to 5MT-35, REMOVAL, Switches and Harness.>
- 3) Remove the transfer case together with the extension case assembly. <Ref. to 5MT-39, REMOVAL, Transfer Case and Extension Case Assembly.>
- 4) Remove the transmission case. <Ref. to 5MT-51, REMOVAL, Transmission Case.>
- 5) Remove the vehicle speed sensor. <Ref. to 5MT-37, REMOVAL, Vehicle Speed Sensor.>
- 6) Remove the snap ring (outer) and pull out the speedometer driven gear. Next, remove the oil seal, speedometer shaft and washer.

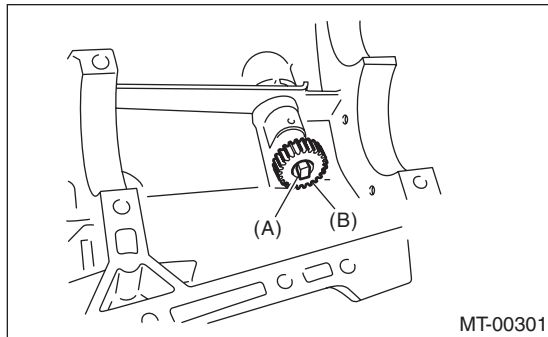

- (A) Snap ring (Outer)
- (B) Speedometer driven gear

B: INSTALLATION

- 1) Install the washer and speedometer shaft, and press fit the oil seal with the ST.

NOTE:

If the oil seal has been removed, use a new oil seal. ST 899824100 or 499827000PRESS

- 2) Install the vehicle speed sensor. <Ref. to 5MT-37, INSTALLATION, Vehicle Speed Sensor.>

- 3) Install the speed meter driven gear and snap ring (outer).

NOTE:

If the oil seal has been removed, use a new snap ring.

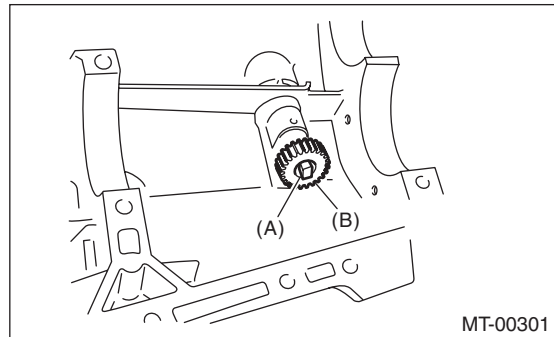

- (A) Snap ring (Outer)
- (B) Speedometer driven gear

- 4) Install the transmission case. <Ref. to 5MT-51, INSTALLATION, Transmission Case.>

- 5) Install the transfer case together with the extension case assembly. <Ref. to 5MT-39, INSTALLATION, Transfer Case and Extension Case Assembly.>

- 6) Install the back-up light switch and neutral position switch. <Ref. to 5MT-35, INSTALLATION, Switches and Harness.>

- 7) Install the manual transmission assembly to the vehicle. <Ref. to 5MT-28, INSTALLATION, Manual Transmission Assembly.>

C: INSPECTION

Check the speedometer driven gear, oil seal and speedometer shaft for damage. Replace if damaged.

20. Reverse Idler Gear

A: REMOVAL

- 1) Remove the manual transmission assembly from the vehicle. <Ref. to 5MT-25, REMOVAL, Manual Transmission Assembly.>
- 2) Remove the back-up light switch and the neutral position switch. <Ref. to 5MT-35, REMOVAL, Switches and Harness.>
- 3) Remove the transfer case together with the extension case assembly. <Ref. to 5MT-39, REMOVAL, Transfer Case and Extension Case Assembly.>
- 4) Remove the transmission case. <Ref. to 5MT-51, REMOVAL, Transmission Case.>
- 5) Remove the drive pinion shaft assembly. <Ref. to 5MT-59, REMOVAL, Drive Pinion Shaft Assembly.>
- 6) Remove the main shaft assembly. <Ref. to 5MT-54, REMOVAL, Main Shaft Assembly.>
- 7) Remove the front differential assembly. <Ref. to 5MT-68, REMOVAL, Front Differential Assembly.>
- 8) Remove the shifter forks and rods. <Ref. to 5MT-78, REMOVAL, Shifter Fork and Rod.>
- 9) Pull out the straight pin, and remove the reverse idler gear shaft, washer, reverse idler gear and washer.

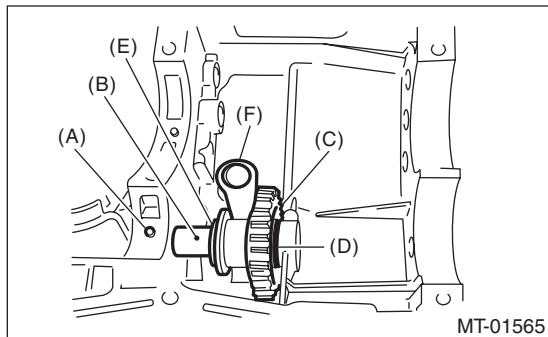

- (A) Straight pin
- (B) Reverse idler gear shaft
- (C) Reverse idler gear
- (D) Washer
- (E) Washer
- (F) Reverse shifter lever

- 10) Remove the reverse shifter lever.

B: INSTALLATION

- 1) Install the reverse shifter lever, washer, reverse idler gear, washer and reverse idler gear shaft, and secure them with the straight pin.

NOTE:

Be sure to install the reverse idler gear shaft from rear side.

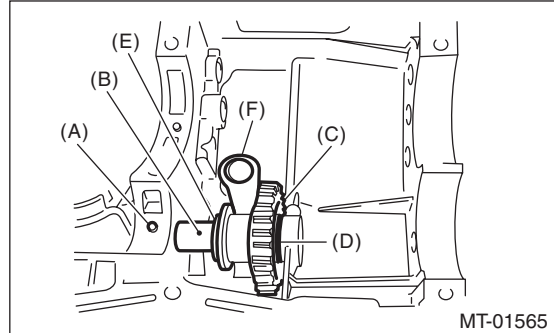

- (A) Straight pin
- (B) Reverse idler gear shaft
- (C) Reverse idler gear
- (D) Washer
- (E) Washer
- (F) Reverse shifter lever

- 2) Check and adjust clearance between the reverse idler gear and the timing case wall surface. <Ref. to 5MT-76, INSTALLATION, Reverse Idler Gear.> <Ref. to 5MT-77, ADJUSTMENT, Reverse Idler Gear.>
- 3) Install the shifter forks and rods. <Ref. to 5MT-78, INSTALLATION, Shifter Fork and Rod.>
- 4) Install the front differential assembly. <Ref. to 5MT-68, INSTALLATION, Front Differential Assembly.>
- 5) Install the main shaft assembly. <Ref. to 5MT-54, INSTALLATION, Main Shaft Assembly.>
- 6) Install the drive pinion shaft assembly. <Ref. to 5MT-59, INSTALLATION, Drive Pinion Shaft Assembly.>
- 7) Install the transmission case. <Ref. to 5MT-51, INSTALLATION, Transmission Case.>
- 8) Install the transfer case together with the extension case assembly. <Ref. to 5MT-39, INSTALLATION, Transfer Case and Extension Case Assembly.>
- 9) Install the back-up light switch and neutral position switch. <Ref. to 5MT-35, INSTALLATION, Switches and Harness.>
- 10) Install the manual transmission assembly to the vehicle. <Ref. to 5MT-28, INSTALLATION, Manual Transmission Assembly.>

C: INSPECTION

1) Move the reverse shifter rod toward the reverse side. Check the clearance between the reverse idler gear and the timing case wall surface. If out of specification, select an appropriate reverse shifter lever and adjust.

Clearance A:

6.0 — 7.5 mm (0.236 — 0.295 in)

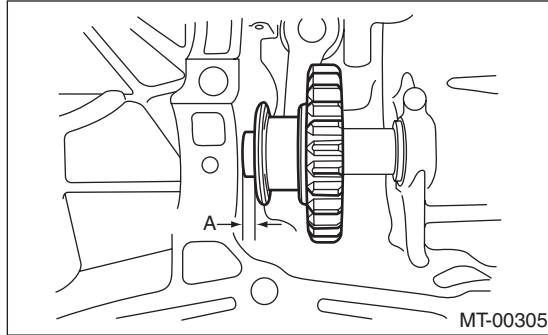

2) After installing a suitable reverse shifter lever, shift into neutral. Check the clearance between the reverse idler gear and the timing case wall surface. If out of specification, select the appropriate washer and adjust.

Clearance:

0 — 0.5 mm (0 — 0.020 in)

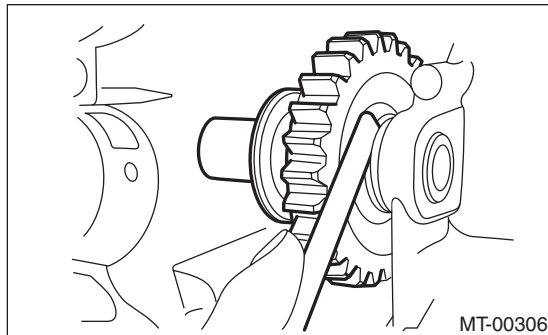

3) Check the reverse idler gear and shaft for damage. Replace if damaged.

D: ADJUSTMENT

1) Select the appropriate reverse shifter lever from the table below, and adjust until the clearance between the reverse idler gear and transmission case wall is within specification.

Clearance A:

6.0 — 7.5 mm (0.236 — 0.295 in)

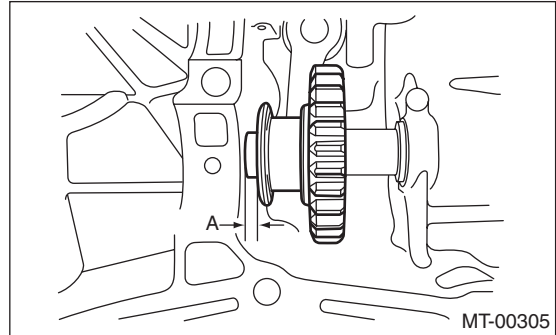

Reverse shifter lever		
Part No.	Mark	Remarks
32820AA070	7	Far from case wall
32820AA080	8	Standard
32820AA090	9	Closer to case wall

2) Select an appropriate washer from the table below, and adjust until the clearance between the reverse idler gear and transmission case wall is within specification.

Clearance:

0 — 0.5 mm (0 — 0.020 in)

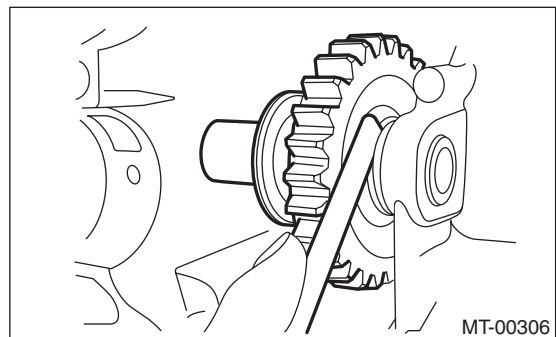

Washer	
Part No.	Thickness mm (in)
803020151	0.4 (0.016)
803020152	1.1 (0.043)
803020153	1.5 (0.059)
803020154	1.9 (0.075)
803020155	2.3 (0.091)

Shifter Fork and Rod

MANUAL TRANSMISSION AND DIFFERENTIAL

21. Shifter Fork and Rod

A: REMOVAL

- 1) Remove the manual transmission assembly from the vehicle. <Ref. to 5MT-25, REMOVAL, Manual Transmission Assembly.>
- 2) Remove the back-up light switch & neutral position switch. <Ref. to 5MT-35, REMOVAL, Switches and Harness.>
- 3) Remove the transfer case together with the extension case assembly. <Ref. to 5MT-39, REMOVAL, Transfer Case and Extension Case Assembly.>
- 4) Remove the transmission case. <Ref. to 5MT-51, REMOVAL, Transmission Case.>
- 5) Remove the drive pinion shaft assembly. <Ref. to 5MT-59, REMOVAL, Drive Pinion Shaft Assembly.>
- 6) Remove the main shaft assembly. <Ref. to 5MT-54, REMOVAL, Main Shaft Assembly.>
- 7) Remove the front differential assembly. <Ref. to 5MT-68, REMOVAL, Front Differential Assembly.>
- 8) Drive out the straight pin by tapping with the ST, and pull out the 5th shifter fork.

ST 398791700 STRAIGHT PIN REMOVER

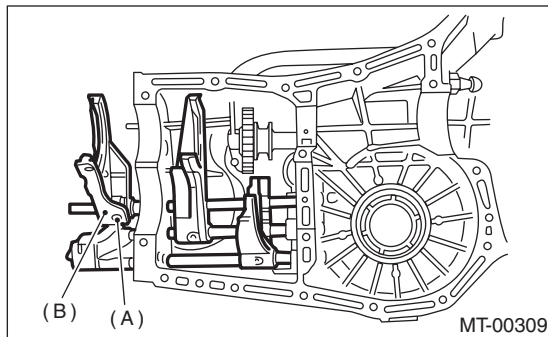

- (A) Straight pin
- (B) 5th shifter fork

- 9) Remove the plugs, springs and check balls.

- 10) Drive out the straight pin, and pull out the 3rd-4th fork rod and shifter fork.

NOTE:

When removing the rod, keep other rods in neutral. Also, when pulling out the straight pin, remove it toward the inside of case so that it does not hit against the case.

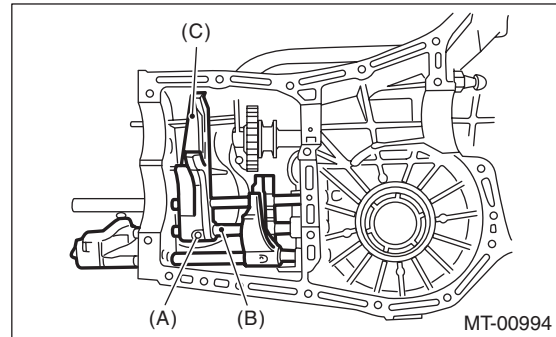

- (A) Straight pin
- (B) 3rd-4th fork rod
- (C) Shifter fork

- 11) Drive out the straight pin, and pull out the 1st-2nd fork rod and shifter fork.

- 12) Remove the snap ring (outer), and pull out the reverse fork rod from reverse fork rod arm. Then take out the ball, spring and interlock plunger from the rod.

And then remove the rod.

NOTE:

When pulling out the reverse fork rod arm, be careful not to let the ball pop out of arm.

- 13) Remove the reverse shifter lever.

B: INSTALLATION

- 1) Install the reverse arm fork spring, ball and interlock plunger to the reverse fork rod arm. Insert the reverse fork rod into the hole of the reverse fork rod arm, and hold it with snap ring (outer) using ST.

NOTE:

Apply grease to plunger to prevent it from falling.

ST 399411700 ACCENT BALL INSTALLER

- 2) Position the ball, spring and new gasket in the reverse fork rod hole on the left side of transmission case, and tighten the checking ball plug.

- 3) Install the 1st-2nd fork rod into 1st-2nd shifter fork through the hole on the rear of transmission case.

- 4) Align the holes in the rod and the fork, and drive the new straight pin into these holes using the ST.

NOTE:

- Set other rods to neutral.
- Make sure the interlock plunger is on the 3rd-4th fork rod side.

ST 398791700 STRAIGHT PIN REMOVER

Shifter Fork and Rod

5) Attach the interlock plunger on 3rd-4th fork rod.

NOTE:

Apply grease to plunger to prevent it from falling.

6) Attach the 3rd-4th fork rod into 3rd-4th shifter fork through the hole on the rear of transmission case.

7) Align the holes in the rod and the fork, and drive the new straight pin into these holes.

NOTE:

- Set the reverse fork rod to neutral.
- Make sure the interlock plunger (before installation) is on the reverse fork rod side.

ST 398791700 STRAIGHT PIN REMOVER

8) Install the 5th shifter fork onto the rear of reverse fork rod. Align the holes in the two parts and drive new straight pin into the specified place.

ST 398791700 STRAIGHT PIN REMOVER

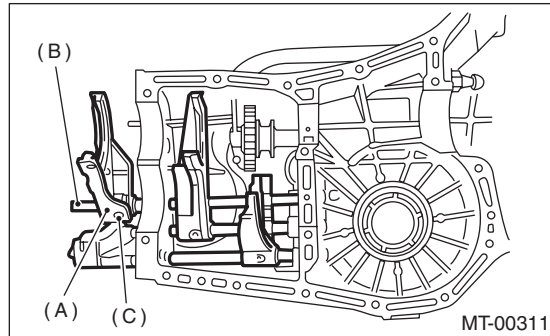

- (A) 5th shifter fork
- (B) Reverse fork rod
- (C) Straight pin

9) Position the balls, check ball springs and new gaskets into holes of the 3rd-4th and 1st-2nd rods, and install the plugs.

Tightening torque:

20 N·m (2.0 kgf·m, 14.5 ft·lb)

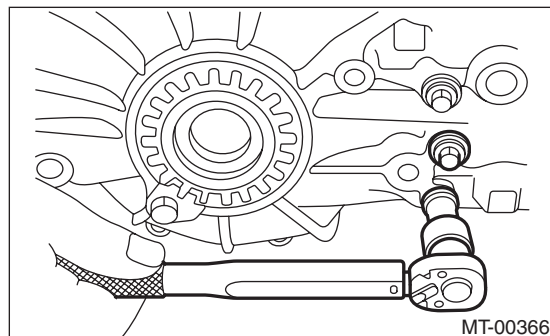

10) Install the front differential assembly. <Ref. to 5MT-68, INSTALLATION, Front Differential Assembly.>

11) Install the main shaft assembly.

<Ref. to 5MT-54, INSTALLATION, Main Shaft Assembly.>

12) Install the drive pinion shaft assembly. <Ref. to 5MT-59, INSTALLATION, Drive Pinion Shaft Assembly.>

13) Install the transmission case. <Ref. to 5MT-51, INSTALLATION, Transmission Case.>

14) Install the transfer case together with the extension case assembly. <Ref. to 5MT-39, INSTALLATION, Transfer Case and Extension Case Assembly.>

15) Install the back-up light switch and the neutral position switch. <Ref. to 5MT-35, INSTALLATION, Switches and Harness.>

16) Install the manual transmission assembly to the vehicle. <Ref. to 5MT-28, INSTALLATION, Manual Transmission Assembly.>

C: INSPECTION

1) Check the fork and rod for damage. Replace if damaged.

2) Gearshift mechanism

Repair or replace the gearshift mechanism if excessively worn, bent or defective in any way.

3) Inspect the clearance between 1st, 2nd driven gear and reverse driven gear. If any clearance is not within specifications, replace the shifter fork as required.

Clearance (a) and (b):
9.5 mm (0.374 in)

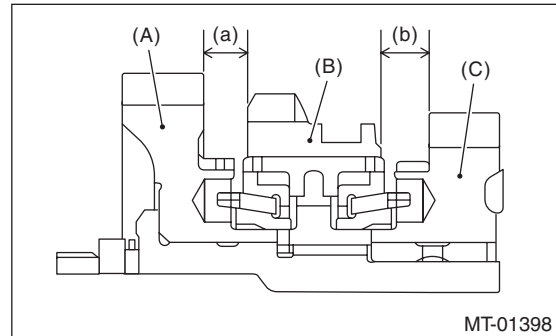

- (A) 1st driven gear
- (B) Reverse driven gear
- (C) 2nd driven gear

1st-2nd shifter fork		
Part No.	Mark	Remarks
32804AA060	1	Approaches 1st gear by 0.2 mm (0.008 in).
32804AA070	No mark	Standard
32804AA080	3	Moves away from 2nd gear by 0.2 mm (0.008 in).

Shifter Fork and Rod

MANUAL TRANSMISSION AND DIFFERENTIAL

4) Inspect the clearance between the 3rd, 4th drive gear and the coupling sleeve. If any clearance is not within specifications, replace the shifter fork as required.

Clearance (a) and (b):
9.3 mm (0.366 in)

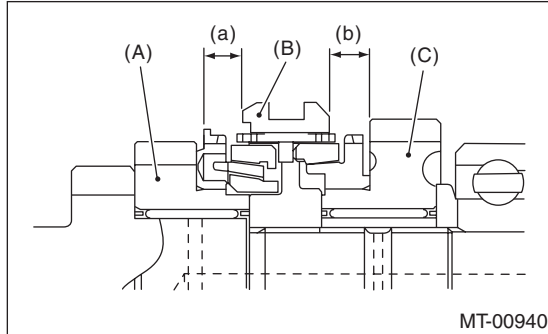

- (A) 3rd drive gear
- (B) Coupling sleeve
- (C) 4th drive gear

3rd-4th shifter fork		
Part No.	Mark	Remarks
32810AA061	1	Approaches 4th gear by 0.2 mm (0.008 in).
32810AA071	No mark	Standard
32810AA101	3	Moves away from 3rd gear by 0.2 mm (0.008 in).

5) Inspect the clearance between 5th drive gear and coupling sleeve. If any clearance is not within specifications, replace the shifter fork as required.

Clearance (a):
9.3 mm (0.366 in)

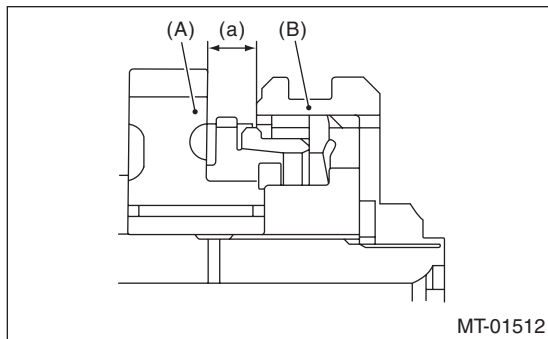

- (A) 5th drive gear
- (B) Coupling sleeve

5th shifter fork (Non-turbo model), Identification paint (pink)		
Part No.	Mark	Remarks
32812AA201	7	Approaches 5th gear by 0.2 mm (0.008 in).
32812AA211	No mark	Standard
32812AA221	9	Moves away from 5th gear by 0.2 mm (0.008 in).

5th shifter fork (Turbo model), Identification paint (blue)		
Part No.	Mark	Remarks
32812AA231	7	Approaches 5th gear by 0.2 mm (0.008 in).
32812AA241	No mark	Standard
32812AA251	9	Moves away from 5th gear by 0.2 mm (0.008 in).

6) Inspect the rod end clearances (A) and (B). If any clearance is not within specifications, replace the rod or fork as required.

Clearance (A):

3rd-4th — 5th:

0.5 — 1.3 mm (0.020 — 0.051 in)

Clearance (B):

1st-2nd — 3rd-4th:

0.4 — 1.4 mm (0.016 — 0.055 in)

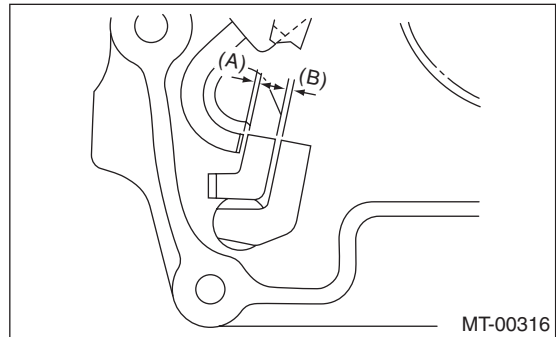

22. General Diagnostic Table

A: INSPECTION

1. MANUAL TRANSMISSION

Symptom	Possible cause	Corrective action
1. Gears are difficult to intermesh. NOTE: The cause for difficulty in shifting gears can be classified into two kinds: One is a defective gear shift system and the other is defective transmission. However, if the operation is heavy and engagement of the gears is difficult, a defective clutch disengagement may also be responsible. Check whether the clutch is correctly functioning, before checking the gear shift system and transmission.	(a) Worn, damaged or burred chamfer at internal spline of the sleeve and reverse driven gear	Replace.
	(b) Worn, damaged or burred chamfer of gear spline	Replace.
	(c) Worn or scratched bushings	Replace.
	(d) Incorrect contact or wear between synchronizer ring and gear cone	Repair or replace.
2. The gear is slipping out • Gear slips out when coasting on rough road. • Gear slips out during acceleration.	(a) Defective pitching stopper adjustment	Adjust.
	(b) Loose engine mounting bolts	Tighten or replace.
	(c) Worn fork shifter, broken shifter fork rail spring	Replace.
	(d) Worn or damaged ball bearing	Replace.
	(e) Excessive clearance between splines of synchronizer hub and synchronizer sleeve	Replace.
	(f) Worn teeth steps on synchronizer hub (caused by slippage of 3rd gear)	Replace.
	(g) Worn 1st driven gear and driven shaft	Replace.
	(h) Worn 2nd driven gear and bushing	Replace.
	(i) Worn 3rd drive gear and needle bearing	Replace.
	(j) Worn 4th drive gear and needle bearing	Replace.
	(k) Worn reverse idler gear and bushing	Replace.
3. Abnormal noise is emitted from the transmission NOTE: If a noise is heard when the vehicle is parked with its engine idling and if a noise ceases when the clutch is disengaged, it may be considered that the noise is coming from the transmission.	(a) Insufficient or improper lubrication	Lubricate with specified oil or replace.
	(b) Worn or damaged gears and bearings NOTE: If the trouble is only wear of the gear teeth surfaces, only a high whirring noise will occur at high speeds, but if any part is broken, rhythmical clicking sounds will be heard even at low speeds.	Replace.

General Diagnostic Table

MANUAL TRANSMISSION AND DIFFERENTIAL

2. DIFFERENTIAL

Symptom	Possible cause	Corrective action
<p>1. Broken differential (case, gear, bearing, etc.)</p> <p>NOTE: Noise will occur, and eventually the differential will not be able to operate due to broken pieces obstructing the gear revolution.</p>	(a) Insufficient or improper oil	Disassemble the differential and replace broken components. At the same time check other components for any trouble, and replace if necessary.
	(b) Use of vehicle under severe conditions such as excessive load and improper use of the clutch	Readjust the preload and backlash of the bearing, and the contact surface of gear.
	(c) Improper adjustment of taper roller bearing	Adjust.
	(d) Improper adjustment of the drive pinion and the hypoid driven gear	Adjust.
	(e) Excessive backlash of a vehicle under severe operating conditions due to worn differential side gear, washer or differential pinion.	Add recommended oil to the specified level. Do not use vehicle under severe operating conditions.
	(f) Loose hypoid driven gear clamping bolts	Tighten.
<p>2. Differential and hypoid gear noises</p> <p>Troubles of the differential and hypoid gear always appear as noise problems. Therefore noise is the first indication of trouble. However, noises from the engine, muffler, tire, exhaust gas, bearing, body, etc. are easily mistaken for the differential noise. Pay special attention to the hypoid gear noise because it is easily confused with other gear noises. There are the following four kinds of noises.</p> <ul style="list-style-type: none"> • Gear noise while driving: If noise increases as the vehicle speed increases, it may be due to insufficient gear oil, incorrect gear engagement, damaged gears, etc. • Gear noise during coasting: Damaged gears due to misadjusted bearings and incorrect shim adjustment. • Noise from bearings during driving or during coasting: Bearing cracked, damaged. • Noise occurring mainly during a turn: Noise from the differential side gear, differential pinion, differential pinion shaft 	(a) Insufficient oil	Lubricate.
	(b) Improper adjustment of hypoid driven gear and drive pinion	Check the tooth contact.
	(c) Worn teeth of hypoid driven gear and drive pinion	Replace as a set. Readjust the bearing preload.
	(d) Loose roller bearing	Readjust the backlash of the hypoid driven gear to drive pinion, and check the tooth contact.
	(e) Distorted hypoid driven gear or differential case	Replace.
	(f) Worn washer and differential pinion shaft	Replace.