

Brought to you by Eris Studios
NOT FOR RESALE

AIRBAG SYSTEM

1. General Description

A: COMPONENT

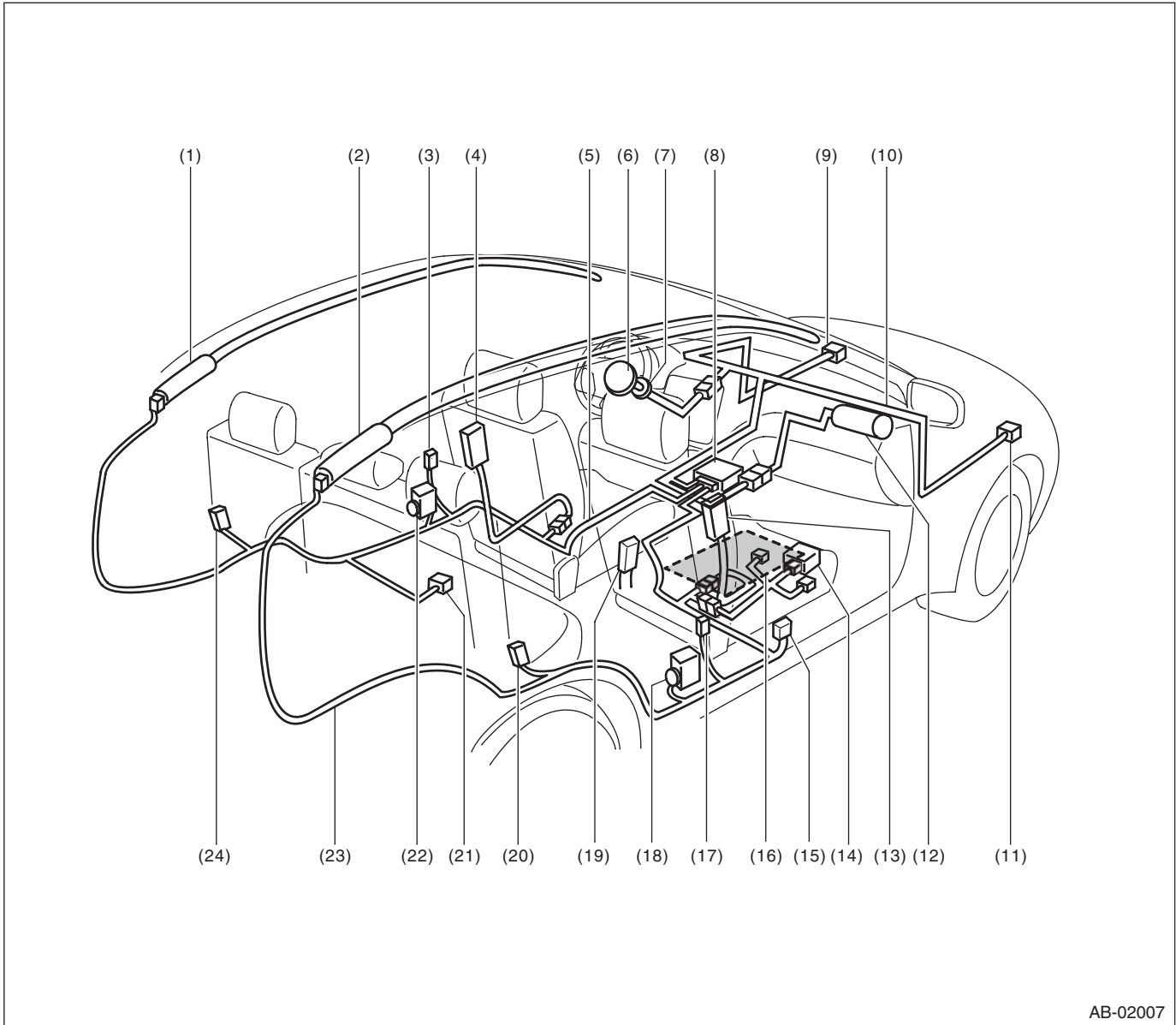

AB-02007

- | | | |
|---|--|--------------------------------|
| (1) Curtain airbag module LH | (9) Front sub sensor LH | (17) Side airbag sensor RH |
| (2) Curtain airbag module RH | (10) Front airbag harness | (18) Seat belt pretensioner RH |
| (3) Side airbag sensor LH | (11) Front sub sensor RH | (19) Buckle switch RH |
| (4) Side airbag module LH | (12) Airbag module ASSY (Passenger) | (20) Curtain airbag sensor RH |
| (5) Airbag rear harness LH | (13) Side airbag module RH | (21) Satellite safing sensor |
| (6) Airbag module ASSY (Driver) | (14) Occupant detection control module | (22) Seat belt pretensioner LH |
| (7) Combination switch ASSY with roll connector | (15) Belt tensioner sensor | (23) Airbag rear harness RH |
| (8) Airbag control module | (16) Occupant detection sensor | (24) Curtain airbag sensor LH |

1. DRIVER'S AIRBAG MODULE

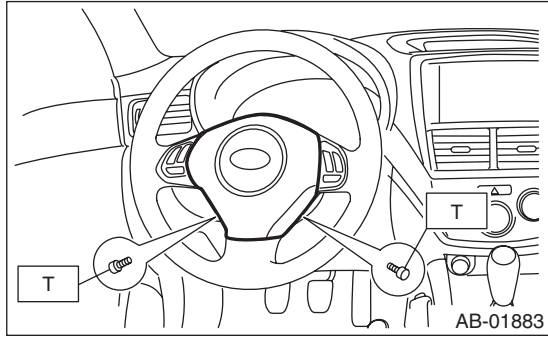

Tightening torque:
 10 N·m (1.0 kgf·m, 7.2 ft·lb)

2. PASSENGER'S AIRBAG MODULE

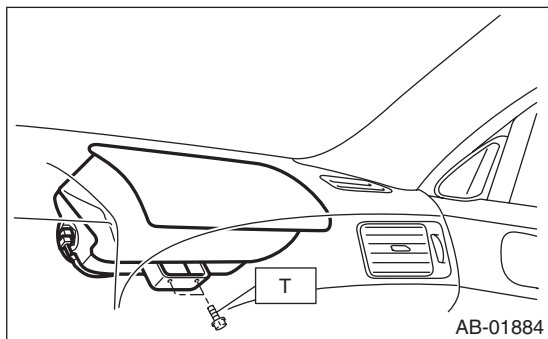

Tightening torque:
 7.5 N·m (0.76 kgf·m, 5.5 ft·lb)

3. SIDE AIRBAG MODULE

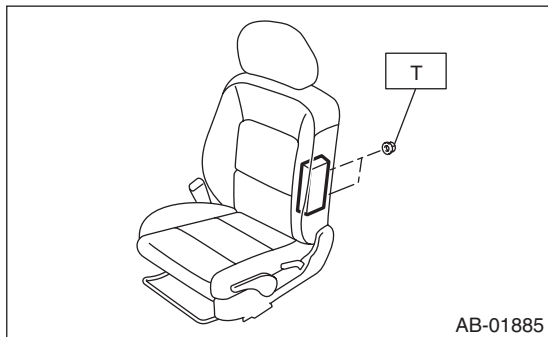

Tightening torque:
 6 N·m (0.61 kgf·m, 4.4 ft·lb)

4. CURTAIN AIRBAG MODULE

- Wagon model

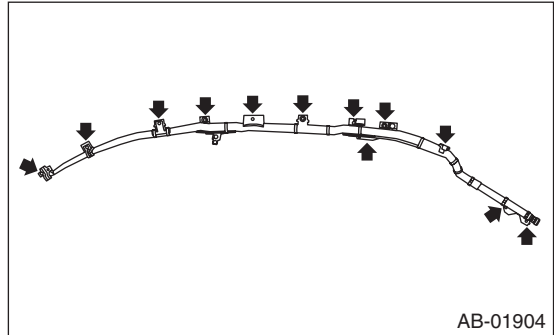

- Sedan model

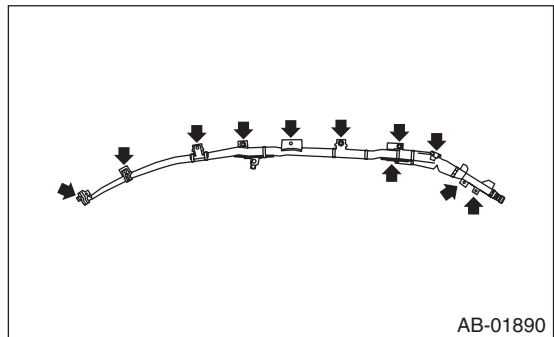

Tightening torque:
 7.5 N·m (0.76 kgf·m, 5.5 ft·lb)

5. AIRBAG CONTROL MODULE

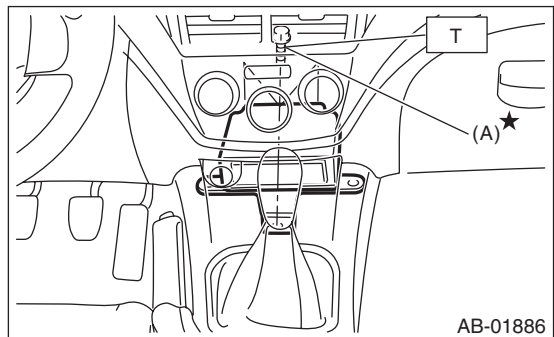

(A) Bolt

Tightening torque:
 25 N·m (2.5 kgf·m, 18.1 ft·lb)

CAUTION:
 Do not reuse mounting bolts and nuts.

AIRBAG SYSTEM

6. FRONT SUB SENSOR

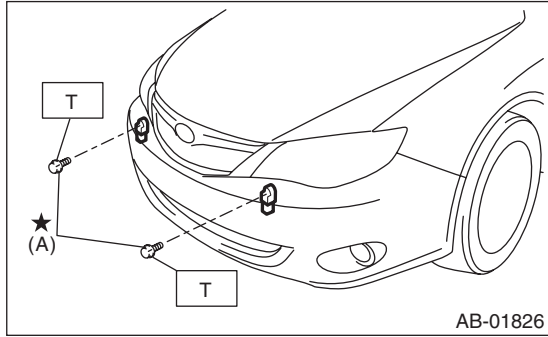

(A) Bolt

Tightening torque:

13 N·m (1.32 kgf·m, 9.6 ft·lb)

CAUTION:

Do not reuse mounting bolts and nuts.

7. SIDE AIRBAG SENSOR

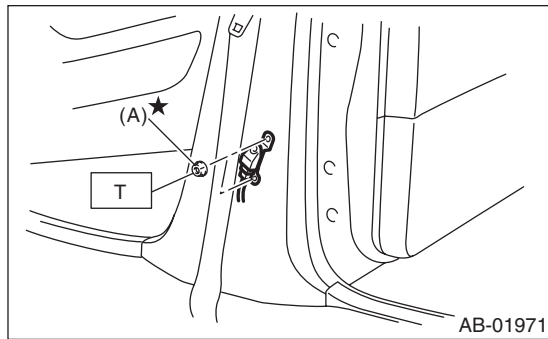

(A) Nut

Tightening torque:

7.5 N·m (0.76 kgf·m, 5.5 ft·lb)

CAUTION:

Do not reuse mounting bolts and nuts.

8. CURTAIN AIRBAG SENSOR

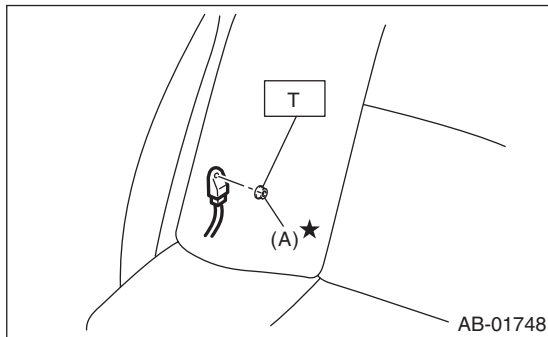

(A) Nut

Tightening torque:

7.5 N·m (0.76 kgf·m, 5.5 ft·lb)

CAUTION:

Do not reuse mounting bolts and nuts.

9. SATELLITE SAFING SENSOR

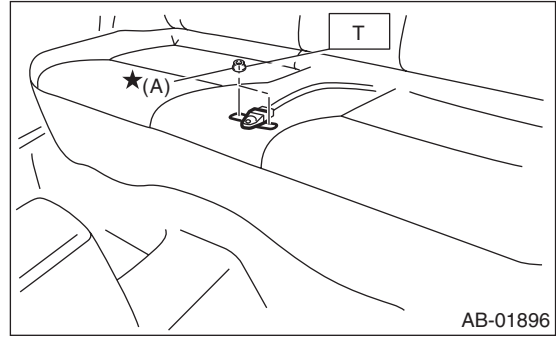

(A) Nut

Tightening torque:

7.5 N·m (0.76 kgf·m, 5.5 ft·lb)

CAUTION:

Do not reuse mounting bolts and nuts.

10. STEERING ROLL CONNECTOR

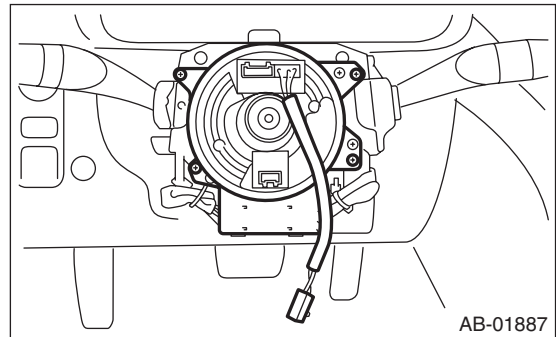

11. AIRBAG HARNESS

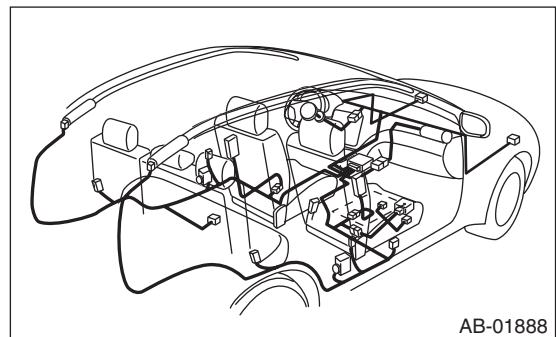

Brought to you by NGOK Studios
NOT FOR RESALE

B: CAUTION

- When servicing a vehicle, be sure to turn the ignition switch to OFF, disconnect the ground cable from battery, and wait for 20 seconds or more before starting work.
- The airbag system is fitted with a backup power source. After disconnecting the battery ground cable, the airbag may deploy if you do not wait for 20 seconds or more before starting airbag system servicing.

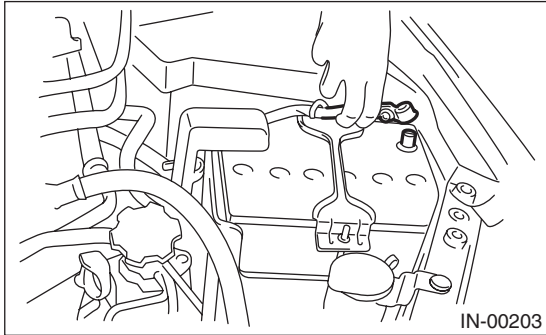

- If the airbag warning light illuminates, repair the vehicle immediately. Otherwise, the airbag or pretensioner may inflate incorrectly, or not inflate in collision.
- If each airbag sensor, airbag module, airbag control module, pretensioner, harness or satellite safing sensor is deformed or damaged, replace with a new part.

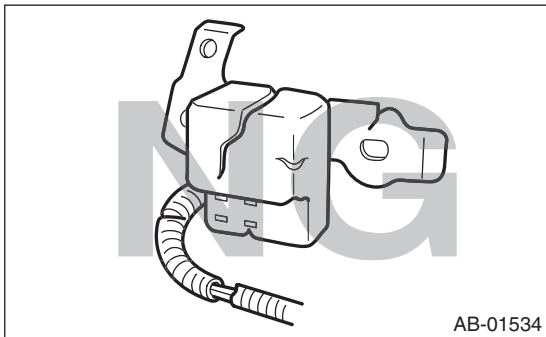

- When checking the airbag system, be sure to use a digital circuit tester. Use of an analog circuit tester may cause the airbag to activate erroneously due to a minimal current inside tester.

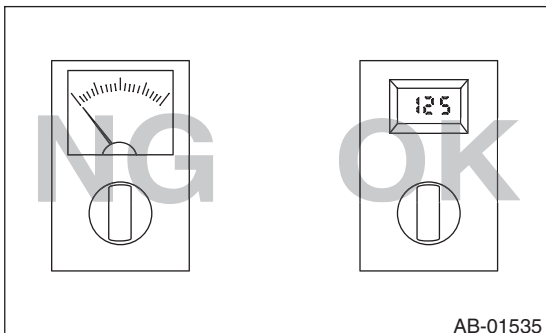

- When checking, use a test harness (1). Damage to connector terminal cause malfunction. Do not directly apply the tester probe to connector terminal of airbag.

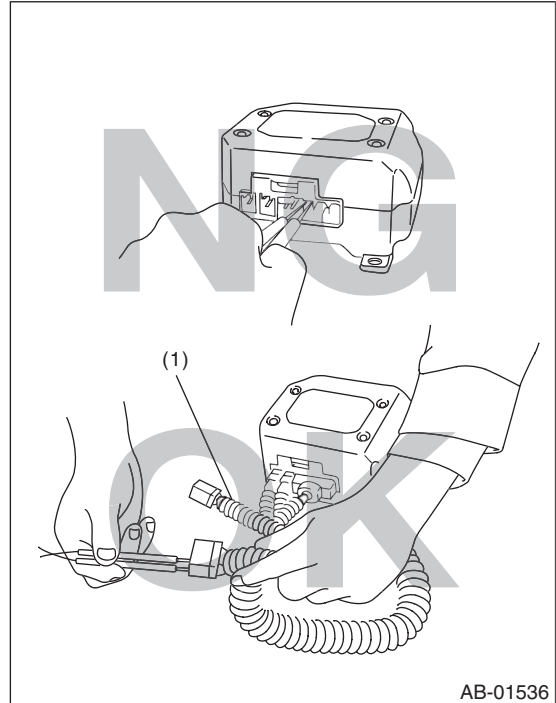

- Do not allow water or oil to come in contact with the connector terminals. Also do not touch the connector terminals.

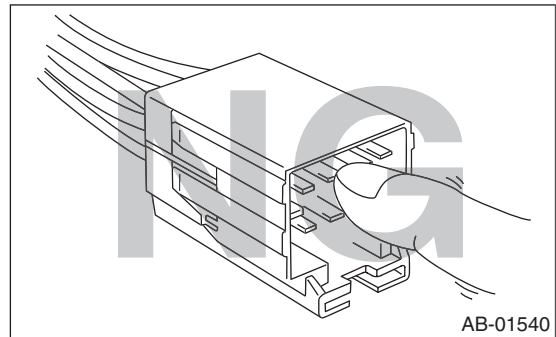

- Do not check continuity of the airbag modules for driver's side, passenger's side and curtain, or the pretensioner.

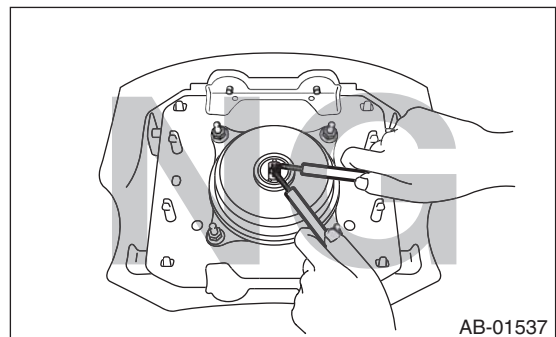

General Description

Brought to you by Eris Studios
NOT FOR RESALE

AIRBAG SYSTEM

- If damage, open circuit or rust is found on airbag system wiring harness, do not use a soldering equipment to repair. Replace the faulty harness with a new genuine part.

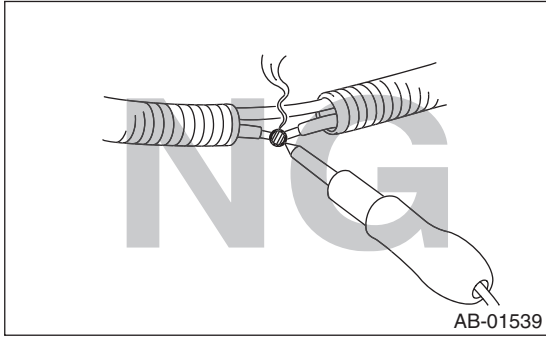

- Install the wiring harness securely with the specified clips to avoid interference or tangled with other parts.

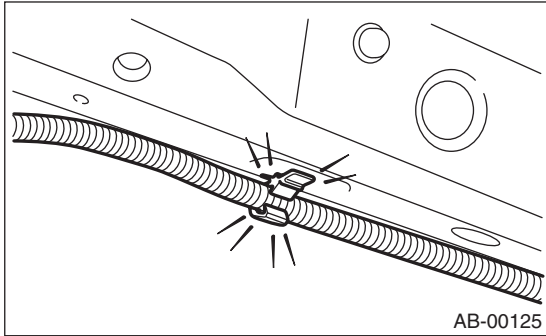

- When painting or performing sheet metal work on the front part of the vehicle, including the front wheel apron, front fender and front side frame, remove the front sub sensors and wiring harness of airbag system.
- When painting or performing sheet metal work on the side of the vehicle, including the side sill, center pillar and front and rear doors, or near the rear floorpan or rear crossmember, remove the side airbag sensors, curtain airbag sensors, satellite safing sensor and wiring harness of the airbag system.

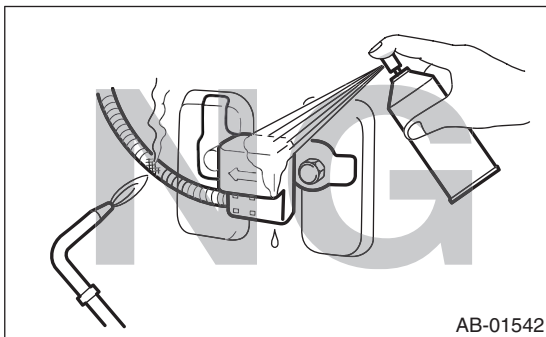

- Do not use the airbag or pretensioner parts from other vehicles. Always replace the defective parts with new parts.
- Never reuse a deployed airbag module and pretensioner.

- Do not discard undeployed airbag module or pretensioner.
- When airbag control module, front sub sensor, side airbag sensor, curtain airbag sensor and satellite safing sensor are removed, do not reuse the bolts and nuts. Always use new bolts and nuts for them.
- Do not drop each airbag module, airbag control module or sensor, subject them to high temperature of 85°C (185°F) or more, or let water, oil or grease get on them; otherwise, the internal parts may be damaged and reliability greatly lowered.

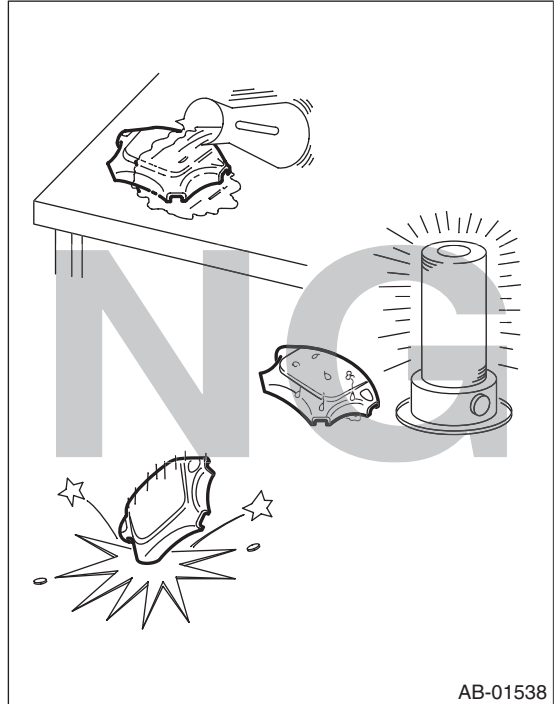

- After removing all the parts of airbag system, keep the airbag module with the pad side facing upward on a dry, clean and flat surface away from heat, light sources, moisture and dust.

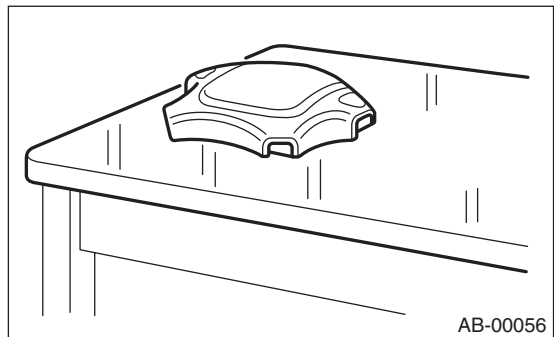

General Description

- The driver's, passenger's, side, curtain airbag modules, and the pretensioner must not be disassembled.

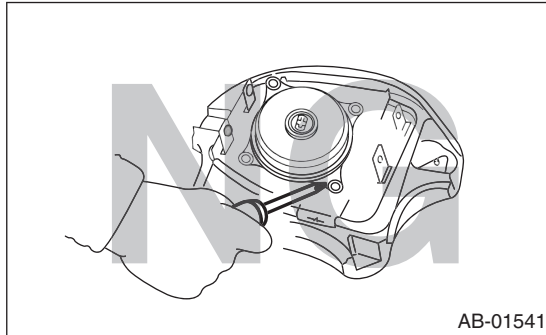

- When installing steering wheel and steering roll connector, be sure to adjust the steering roll connector.
- The removed front seat with airbag module must be kept at least 200 mm (8 in) away from walls and other objects.

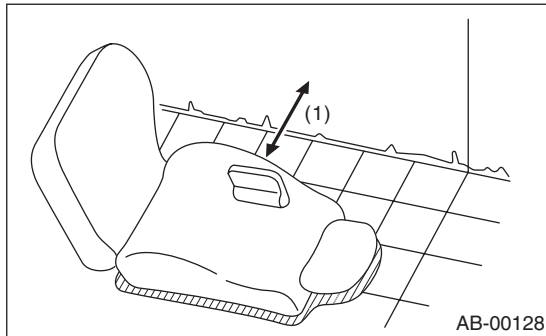

(1) 200 mm (8 in) or more

General Description

Brought to you by Eris Studios
NOT FOR RESALE

AIRBAG SYSTEM

- When storing a removed airbag module, do not place it with the pad side of airbag facing downward. Do not place any objects on the airbag module. Do not pile up the airbag module. If the airbag inflates for some reason when an airbag module pad is touching other objects, it may cause serious accident.

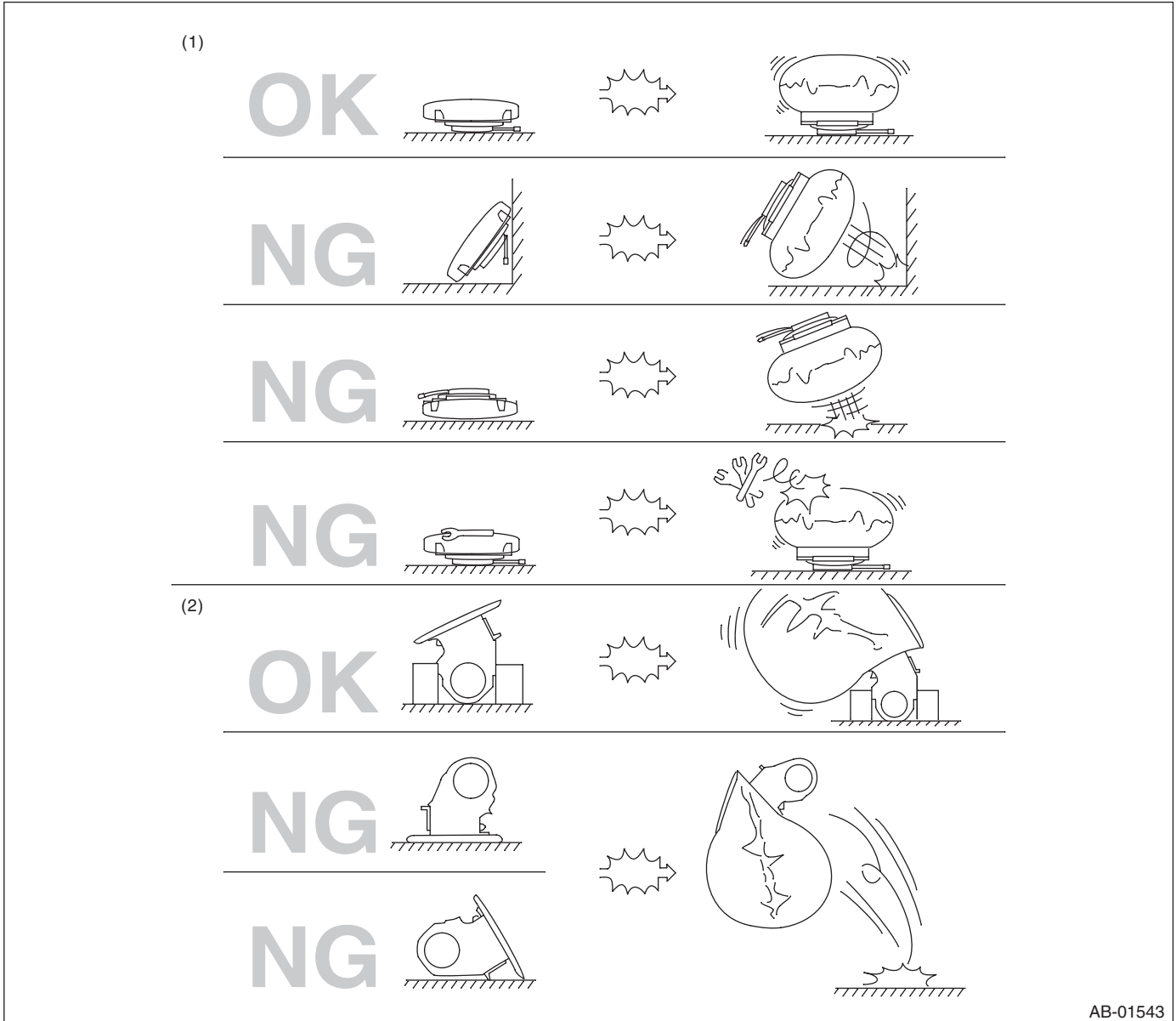

(1) Driver's airbag module

(2) Passenger's airbag module

C: PREPARATION TOOL

1. GENERAL TOOL

TOOL NAME	REMARKS
TORX®T30	Used for removal/installation of driver's airbag module

2. Airbag Connector

A: PROCEDURE

1. POWER SUPPLY

1) How to disconnect:

(1) Push lock (A), then disconnect the connector.

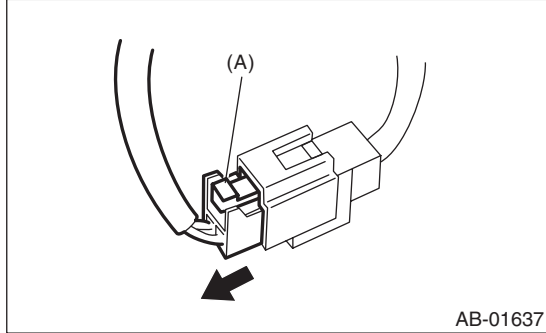

CAUTION:

When pulling the slide lock or disconnecting connector, be sure to hold the connector, not the harness.

2) How to connect:

Holding the connector, push it in securely until a clicking sound is heard.

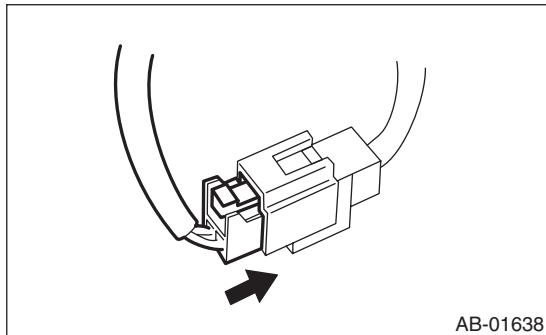

CAUTION:

Be sure to insert the connector in until it is locked. Then pull it gently to make sure that it is locked.

2. AIRBAG CONTROL MODULE

1) How to disconnect:

Press the lock lever plate (A) and pull out the lock lever.

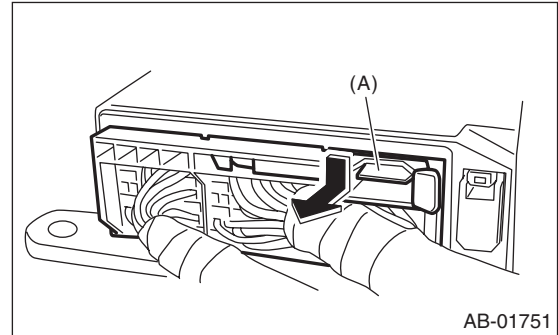

2) How to connect:

Insert the connector, push the lock lever in securely.

CAUTION:

Be sure to insert the connector in until it is locked. Then pull it lightly to make sure that it is locked.

Airbag Connector

AIRBAG SYSTEM

Brought to you by Eris Studios
NOT FOR RESALE

3. DRIVER'S AIRBAG (BETWEEN AIRBAG MAIN HARNESS AND ROLL CONNECTOR) AND PASSENGER'S AIRBAG

1) How to disconnect:

(1) Push the slide lock (A) in the direction of arrow.

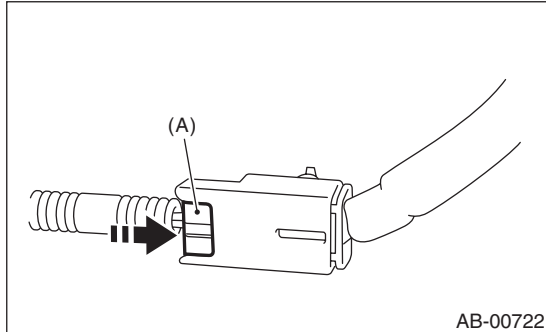

AB-00722

(2) With the slide lock pushed, disconnect the connector.

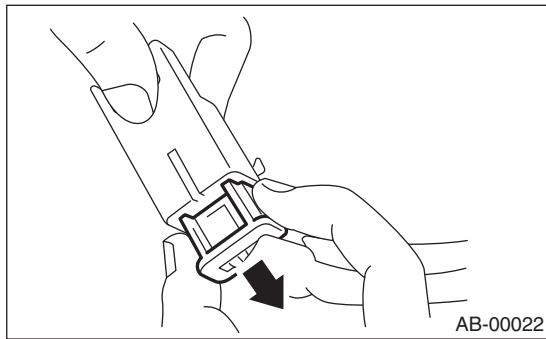

AB-00022

CAUTION:

When pulling the slide lock or disconnecting connector, be sure to hold the connector, not the harness.

2) How to connect:

Holding the connector, push it in securely until a clicking sound is heard.

CAUTION:

Be sure to insert the connector in until it is locked. Then pull it gently to make sure that it is locked.

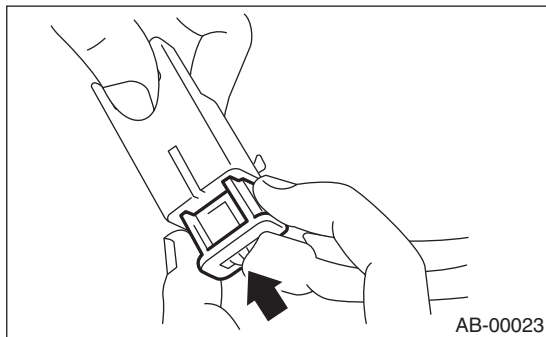

AB-00023

4. DRIVER'S AIRBAG MODULE, CURTAIN AIRBAG MODULE AND PRETENSIONER

1) How to disconnect:

(1) Using a flat tip screwdriver, pry the push lock upward to unlock.

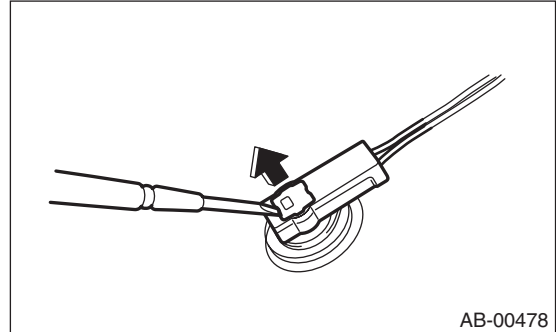

AB-00478

(2) Pull the connector to disconnect from the driver's airbag module assembly or the retractor assembly.

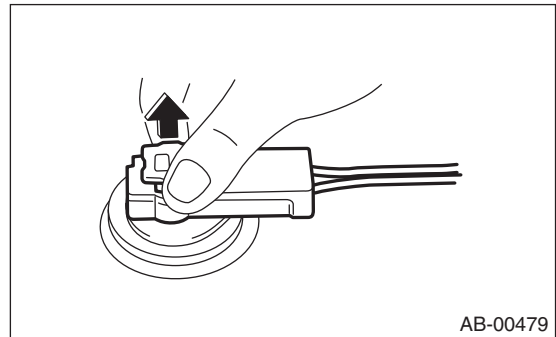

AB-00479

2) How to connect:

Connect the connector in the reverse order of disconnecting. At this time, be sure to insert until a clicking sound is heard.

CAUTION:

• Be sure to insert the connector in until it is locked.

• Be sure to push the push lock in securely. Then pull it gently to make sure that it is locked.

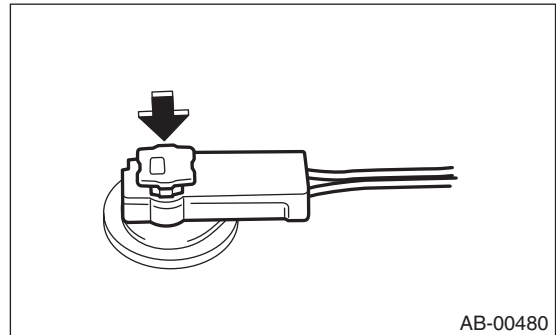

AB-00480

5. FRONT SUB SENSOR, SIDE AIRBAG SENSOR, CURTAIN AIRBAG SENSOR AND SATELLITE SAFING SENSOR

1) How to disconnect:
Holding outer part (A), pull it in the direction of arrow.

CAUTION:
When pulling the slide lock or disconnecting connector, be sure to hold the connector, not the harness.

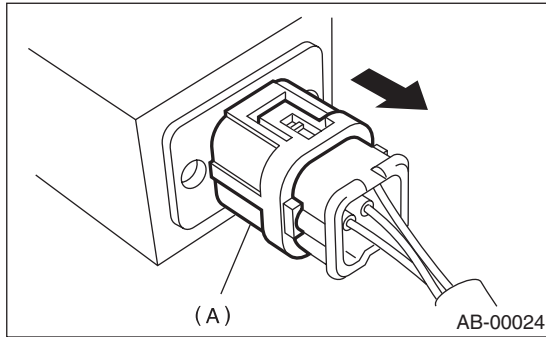

2) How to connect:
Holding the connector, push it in securely until a clicking sound is heard.

CAUTION:

- Do not touch the outer side section or else the outer side (A) will move back.
- Be sure to insert the connector in until it is locked. Then pull it gently to make sure that it is locked.

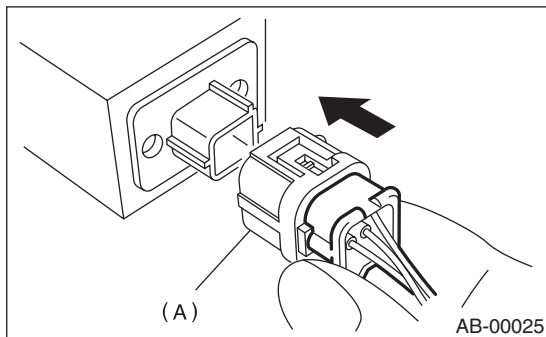

6. SIDE AIRBAG MODULE

1) How to disconnect:
(1) Move the slide lock (A) in the direction of arrow and hold it.
(2) With the slide lock (A) moved, pull the connector (B) in the direction of arrow.

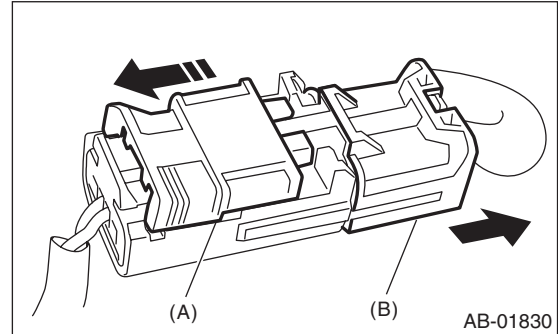

CAUTION:
When pulling the slide lock or disconnecting connector, be sure to hold the connector, not the harness.

2) How to connect:
Holding the connector, push it in securely until a clicking sound is heard.

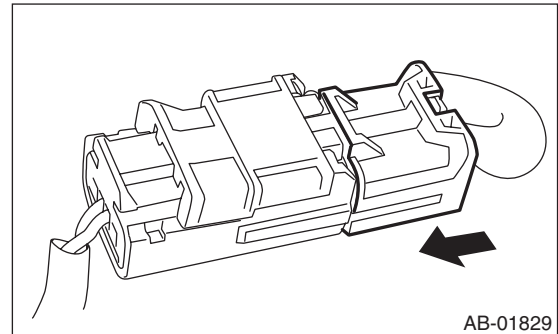

CAUTION:
Be sure to insert the connector in until it is locked. Then pull it lightly to make sure that it is locked.

7. BUCKLE SWITCH RH

1) How to disconnect:

- (1) Move the slide lock (A) in the direction of arrow and hold it.
- (2) With the slide lock (A) moved, pull the connector (B) in the direction of arrow.

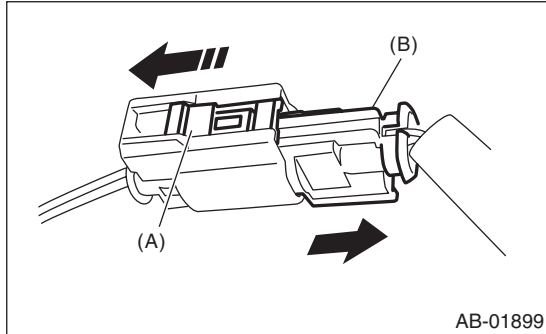

CAUTION:

When pulling the slide lock or disconnecting connector, be sure to hold the connector, not the harness.

2) How to connect:

Holding the connector, push it in securely until a clicking sound is heard.

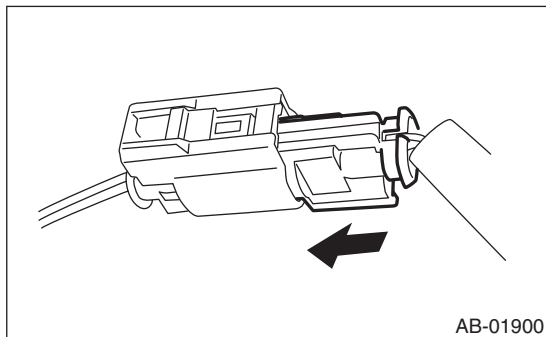

CAUTION:

Be sure to insert the connector in until it is locked. Then pull it gently to make sure that it is locked.

3. Inspection Locations After a Collision

A: REPLACEMENT

Replace the following parts when the airbag is deployed.

1. FRONT COLLISION

- 1) Driver's airbag module
- 2) Passenger's airbag module
- 3) Driver's seat belt (Pretensioner)
- 4) Passenger's seat belt (Pretensioner)
- 5) Airbag control module
- 6) Front sub sensor
- 7) Roll connector
- 8) Passenger's side seat cushion pad and frame assembly
- 9) Instrument panel (for integrating with passenger's airbag module)

2. SIDE COLLISION

- 1) Airbag control module
- 2) Satellite safing sensor
- 3) Satellite safing sensor cover
- 4) Side airbag module (operating side seat backrest)
- 5) Side airbag sensor (operating side)
- 6) Curtain airbag module (operating side)
- 7) Curtain airbag sensor (operating side)

3. INSPECTION OF OTHER PARTS

Check for the following parts, and replace the damaged parts with new parts.

- 1) Steering wheel and steering shaft

Check the steering shaft for mounting conditions and deflection of front and rear, upward and downward directions, and deflection of front and rear direction with tilt lever released. (After a collision, absorbing part of steering shaft may have been operated.)

- 2) Check the direct type connector of driver's airbag module, curtain airbag module, pretensioner, etc. for damage, and also check each harness for pinch and connector damage. Replace the main harness as a unit if damage is found.

- 3) Check the seat cushion, backrest, seat rail and headrest for installing condition and play.

- 4) For the passenger's seat, replace the seat cushion pad frame assembly with a new part if the seat cushion frame assembly is deformed or cracked.

- 5) If there are tears or loosening in the passenger side seat cushion cover, it may interfere with the proper operation of the passenger detection system. Replace with a new cushion cover.

- 6) Be sure to perform the system calibration for the occupant detection system after removing or replacing the passenger seat cushion cover. Failure to do so may cause improper operation of the occupant detection system. <Ref. to OD(diag)-15, SYSTEM CALIBRATION (REZEROING), OPERATION, Subaru Select Monitor.>

- 7) Use the Subaru Select Monitor to check whether the passenger's seat belt buckle switch is operating normally.

AIRBAG SYSTEM

B: INSPECTION

If the vehicle is involved in a collision, even if it is a slight collision, be sure to check the following systems.

1. DRIVER'S AIRBAG MODULE

1) Check for the following, and replace the damaged parts with new parts.

- Airbag module is cracked or deformed.
- Harness and/or connector is cracked, deformed or open.
- Harness wire is exposed.
- The module surface is fouled with grease, oil, water or cleaning solvent.

2) When installing a new driver's airbag module, check for the following, and replace the damaged parts with new parts.

- The steering wheel is in the way, making it difficult to install the airbag module.
- The clearance between the driver's airbag module and steering wheel is not constant.
- When steering wheel deformation in axial and vertical directions exceed limits.

Standard:

Axial deflection A

Less than 6 mm (0.24 in)

Vertical deflection L

Less than 17 mm (0.68 in)

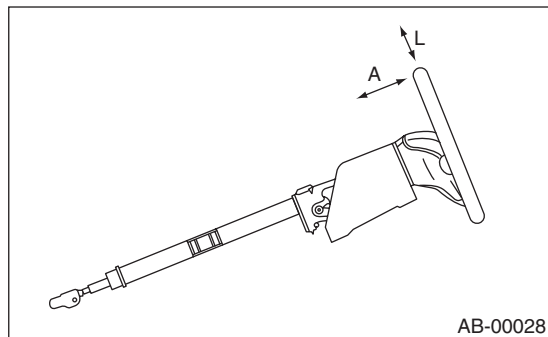

2. PASSENGER'S AIRBAG MODULE

Check for the following, and replace the damaged parts with new parts.

- Airbag module is cracked or deformed.
- Harness and/or connector is cracked, deformed or open.
- Harness wire is exposed.
- Mounting bracket is cracked or deformed.

3. SIDE AIRBAG MODULE

Check for the following, and replace the damaged parts with new parts.

- Front seat, airbag module and mounting bracket are damaged or deformed.
- Harness and/or connector is cracked, deformed or open.
- Harness wire is exposed.

4. CURTAIN AIRBAG MODULE

Check for the following, and replace the damaged parts with new parts.

- Airbag cover is scratched or torn.
- Harness and/or connector is cracked, deformed or open.
- Harness wire is exposed.
- Mounting bracket and securing clip are cracked or deformed.

5. AIRBAG CONTROL MODULE

Check for the following, and replace the damaged parts with new parts.

- Control module is cracked or deformed.
- Mounting bracket is cracked or deformed.
- Connector is scratched, cracked or deformed.
- Airbag is deployed.
- Side airbag is deployed.
- Curtain airbag is deployed.

6. FRONT SUB SENSOR

If the section of vehicle as shown in the figure is damaged, check the following items and replace the damaged parts with new parts.

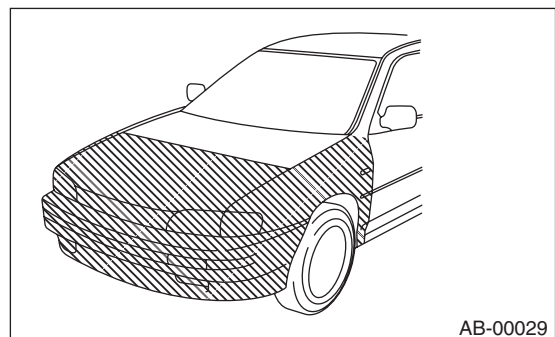

- Front sub sensor is cracked or deformed.
- Connector is scratched, cracked or deformed.
- Airbag is deployed.

7. SATELLITE SAFING SENSOR, SIDE AIRBAG SENSOR AND CURTAIN AIRBAG SENSOR

If the section of vehicle as shown in the figure is damaged, check the following items and replace the damaged parts with new parts.

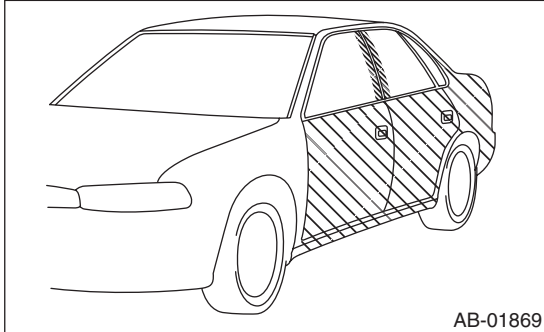

- Satellite safing sensor, side airbag sensor and curtain airbag sensor are cracked or deformed.
- Mounting bracket is cracked or deformed.
- Satellite safing sensor is cracked or deformed.
- Connector is scratched, cracked or deformed.
- Side airbag or curtain airbag is deployed. (operating side)

8. ROLL CONNECTOR

Check for the following, and replace the damaged parts such as cracks, deformation, etc. with new parts.

- Combination switch
- Steering roll connector

9. STEERING SHAFT

Measure the overall length of steering column. If the length is not within the specification, the steering column may be damaged. Replace it with a new part.

Standard: Overall length L

Tilt column

$$833.6^{+1.3}_{-0.3} \text{ mm } (32.82^{+0.051}_{-0.012} \text{ in})$$

Tilt and telescopic column (measure while minimized)

$$818.6^{+1.5}_{-1.5} \text{ mm } (32.23^{+0.059}_{-0.059} \text{ in})$$

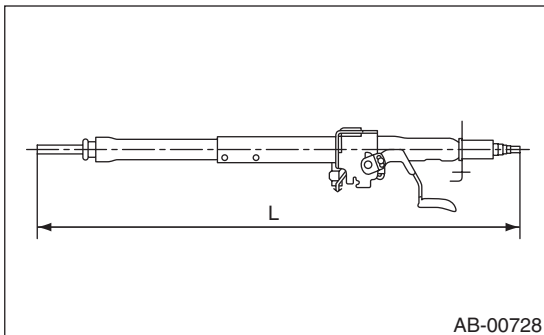

10. PASSENGER'S SEAT

1) Check for the following, and replace the damaged parts with new parts.

- Seat belt buckle body or bracket is scratched, cracked or deformed.
- Backrest frame for crack or deformation
- Headrest for deformation or play
- If the seat cushion cover and seat backrest cover is scratched or coming loose, replace with a new cover and readjust the system. <Ref. to OD(diag)-15, SYSTEM CALIBRATION (REZEROING), OPERATION, Subaru Select Monitor.>

CAUTION:

If any of the following applies, replace the seat cushion pad and frame assembly. Do not disassemble.

- Cracks or deformation found in the seat cushion frame or seat cushion pad.
- Scratches, cracks, or deformation found on the passenger detection system pressure sensor hoses or passenger detection control module, or attachment brackets of the control module.
- Harness and/or connector is cracked, deformed or open. Harness wire is exposed.

2) After checking the installing condition of passenger's seat, perform the system calibration of occupant detection system. <Ref. to OD(diag)-15, SYSTEM CALIBRATION (REZEROING), OPERATION, Subaru Select Monitor.>

11. BELT TENSION SENSOR

Check for the following, and replace the damaged parts with new parts.

- Belt tension sensor is scratched, cracked, or deformed.
- Harness and/or connector is cracked, deformed or open. Harness wire is exposed.

4. Driver's Airbag Module

A: REMOVAL

CAUTION:

Refer to "CAUTION" of "General Description" before handling the airbag module. <Ref. to AB-5, CAUTION, General Description.>

- 1) Position the front wheels straight ahead. (After moving a vehicle 5 m (16 ft) or more with front wheels positioned straight ahead, make sure that the vehicle moves straight ahead.)
- 2) Turn the ignition switch to OFF.
- 3) Disconnect the ground cable from battery and wait for at least 20 seconds before starting work.
- 4) Using TORX® bit T30 (1), remove the two TORX® bolts on the side of steering wheel.

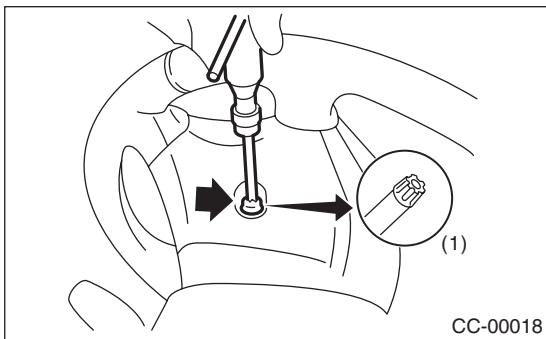

- 5) Disconnect the horn harness.
- 6) Disconnect the airbag connector on the back of airbag module, and then remove the airbag module. <Ref. to AB-9, PROCEDURE, Airbag Connector.>

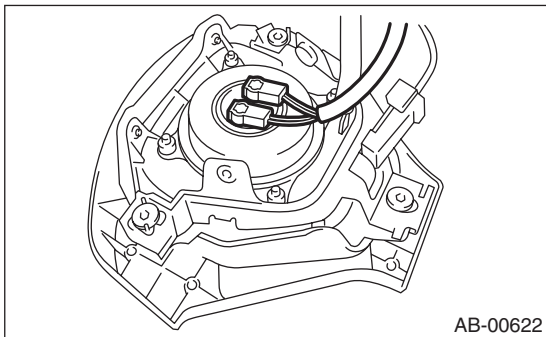

- 7) Refer to "CAUTION" for handling of a removed airbag module. <Ref. to AB-5, CAUTION, General Description.>

B: INSTALLATION

CAUTION:

- Refer to "CAUTION" of "General Description" before handling the airbag module. <Ref. to AB-5, CAUTION, General Description.>
 - Do not allow harness and connectors to interfere or get tangled up with other parts.
- Install in the reverse order of removal.

Tightening torque:

10 N·m (1.0 kgf-m, 7.2 ft-lb)

C: INSPECTION

CAUTION:

- Refer to "CAUTION" of "General Description" before handling the airbag module. <Ref. to AB-5, CAUTION, General Description.>
 - Do not allow harness and connectors to interfere or get tangled up with other parts.
- Check for the following, and replace the damaged parts with new parts. <Ref. to AB-14, DRIVER'S AIRBAG MODULE, INSPECTION, Inspection Locations After a Collision.>
- Airbag module
 - Harness
 - Connector
 - Mounting bracket

5. Passenger's Airbag Module

A: REMOVAL

CAUTION:

Refer to "CAUTION" of "General Description" before handling the airbag module. <Ref. to AB-5, CAUTION, General Description.>

- 1) Turn the ignition switch to OFF.
- 2) Disconnect the ground cable from battery and wait for at least 20 seconds before starting work.
- 3) Remove the instrument panel. <Ref. to EI-51, REMOVAL, Instrument Panel Assembly.>
- 4) Remove the claw, and remove the passenger's airbag module.

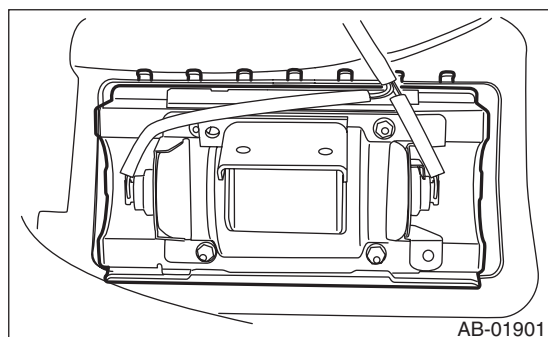

- 5) Refer to "CAUTION" for handling of a removed airbag module. <Ref. to AB-5, CAUTION, General Description.>

B: INSTALLATION

CAUTION:

Do not allow harness and connectors to interfere or get tangled up with other parts.

Install in the reverse order of removal.

Tightening torque:

7.5 N·m (0.76 kgf-m, 5.5 ft-lb)

C: INSPECTION

CAUTION:

Refer to "CAUTION" of "General Description" before handling the airbag module. <Ref. to AB-5, CAUTION, General Description.>

Check for the following, and replace the damaged parts with new parts. <Ref. to AB-14, PASSENGER'S AIRBAG MODULE, INSPECTION, Inspection Locations After a Collision.>

- Airbag module
- Harness
- Connector
- Mounting bracket

6. Side Airbag Module

A: REMOVAL

CAUTION:

Refer to “CAUTION” of “General Description” before handling the airbag module. <Ref. to AB-5, CAUTION, General Description.>

NOTE:

Remove the passenger’s side by referring to driver’s side.

- 1) Turn the ignition switch to OFF.
- 2) Disconnect the ground cable from battery and wait for at least 20 seconds before starting work.
- 3) Remove the front seat from the vehicle. <Ref. to SE-6, REMOVAL, Front Seat.>
- 4) Remove the clip from reverse side of seat cushion assembly and slide rail, and then remove the side airbag harness.
- 5) Remove the side airbag harness from backrest frame assembly.
- 6) Remove the plastic fastener at the bottom-back side of backrest.

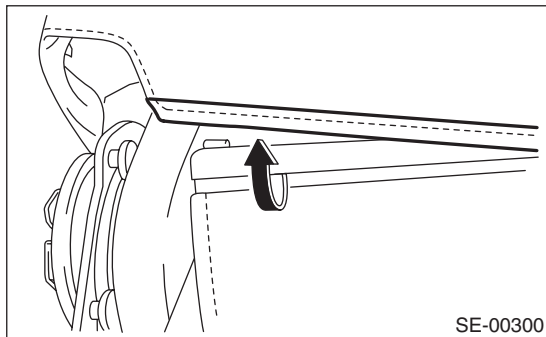

- 7) Open the fastener at the rear side of backrest.

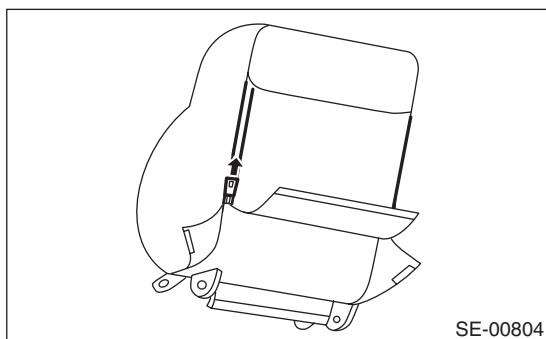

- 8) Remove the hog rings of backrest cover.

CAUTION:

When removing the hog rings, be careful not to tear the vinyl sheet within the seat. If the sheet has torn, replace it with a new sheet.

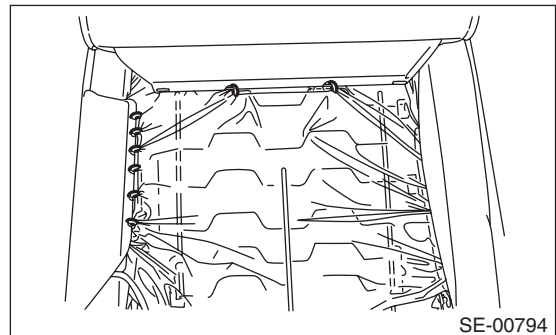

- 9) Remove the pad (A) and then remove the mounting nuts for side airbag module.

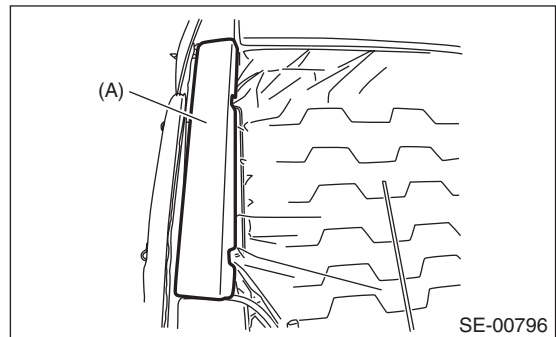

- 10) Remove the side airbag harness from backrest frame assembly.

B: INSTALLATION

CAUTION:

- Refer to “CAUTION” of “General Description” before handling the airbag module. <Ref. to AB-5, CAUTION, General Description.>
- Be sure to perform the system calibration for occupant detection system after passenger’s seat installation. <Ref. to OD(diag)-15, SYSTEM CALIBRATION (REZEROING), OPERATION, Sub-aru Select Monitor.>

- 1) Make sure that there is no foreign matter on side airbag module.
- 2) Install the side airbag module (A) to backrest frame assembly.

CAUTION:

When installing the side airbag module assembly, be sure to install it by inserting the side airbag module between the backrest cover and airbag guide cloth.

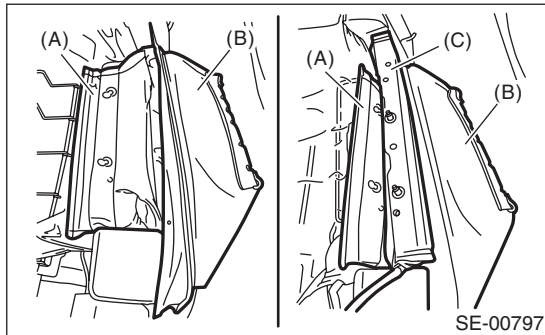

- (A) Airbag guide cloth
- (B) Backrest cover
- (C) Side airbag module ASSY

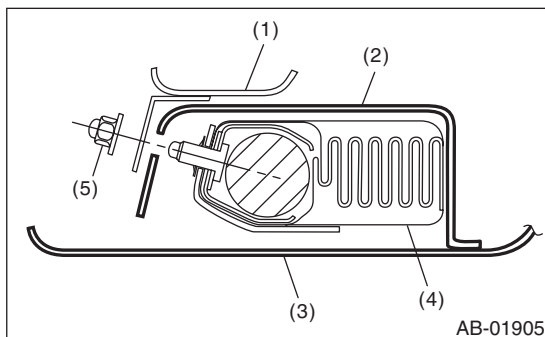

- (1) Backrest frame ASSY
- (2) Airbag guide cloth
- (3) Backrest cover
- (4) Side airbag module ASSY
- (5) Hexagon cap nut

When the backrest cover is not installed securely, the side airbag module may not be deployed properly, therefore keep strictly to the following procedure.

- Be careful not to stain or damage the backrest cover during assembly.
- Always use new hog rings.
- Secure the hog ring using hog ring pliers.
- Install the hog rings to the specified points securely and make sure that no wrinkle or twisting on backrest cover.

Tightening torque:

6.0 N-m (0.61 kgf-m, 4.4 ft-lb)

- 3) Install the side airbag harness to backrest frame assembly.
- 4) Install the backrest cover.
- 5) Install the side airbag harness to the clip of the slide rail IN.
- 6) Recline the seat or slide it backward and forward, and check there is no contact between the seat backrest assembly, cushion cover assembly and side airbag harness.

C: INSPECTION

CAUTION:

Refer to “CAUTION” of “General Description” before handling the airbag module. <Ref. to AB-5, CAUTION, General Description.>

Check for the following, and replace damaged parts with new parts. <Ref. to AB-14, SIDE AIRBAG MODULE, INSPECTION, Inspection Locations After a Collision.>

- 1) With side collision (when side airbag is deployed)
 - Side airbag module assembly
 - Satellite safing sensor
 - Side airbag sensor
 - Curtain airbag sensor
 - Backrest pad assembly
 - Backrest frame assembly
 - Backrest cover assembly
- 2) When damage is found by visual check
 - Headrest assembly
 - Headrest lock bushing
 - Outer slide rail
 - Inner slide rail
 - Seat hinge cover
 - Seat lifter lever
 - Reclining lever
 - Side airbag harness and connector on body side
 - Satellite safing sensor cover
- 3) With side collision (when side airbag is not deployed)

Check the seat, airbag module, sensor visually, and then replace them with new parts if damaged or cracked.

Specially inspect the damage of airbag module body, mounting bracket and harness connector.
- 4) Without side collision (dirt and damage of cover)

Replace the corresponding part with a new part.

7. Curtain Airbag Module

A: REMOVAL

CAUTION:

Refer to “CAUTION” of “General Description” before handling the airbag module. <Ref. to AB-5, CAUTION, General Description.>

- 1) Turn the ignition switch to OFF.
- 2) Disconnect the ground cable from battery and wait for at least 20 seconds before starting work.
- 3) Remove the rear quarter trim. <Ref. to EI-55, REMOVAL, Rear Quarter Trim.>
- 4) Disconnect the curtain airbag module connector.

- Wagon model

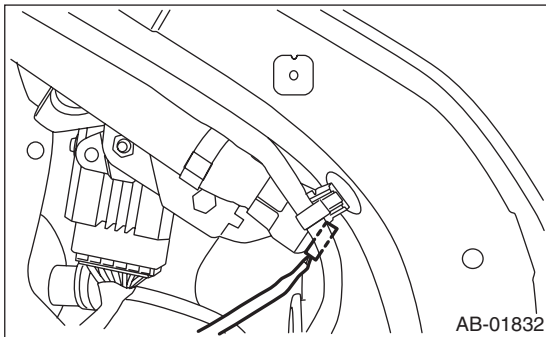

- Sedan model

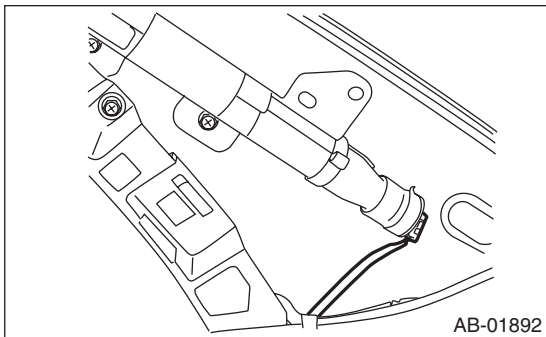

5) Remove the roof trim. <Ref. to EI-61, REMOVAL, Roof Trim.>

6) Remove the airbag guide from the front pillar.

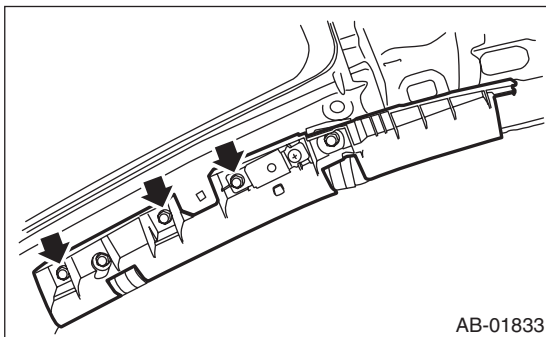

7) Remove the bolts and then remove the curtain airbag module.

CAUTION:

- Be careful not to damage the curtain airbag module during removal.
- Never open the curtain airbag module before deploying it. Never reuse the deployed curtain airbag module.
- Wagon model

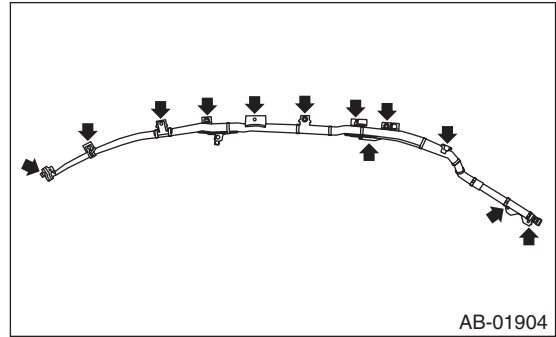

- Sedan model

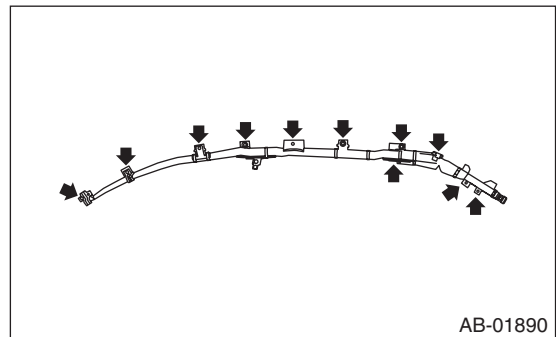

B: INSTALLATION

CAUTION:

- Refer to “CAUTION” of “General Description” before handling the airbag module. <Ref. to AB-5, CAUTION, General Description.>
- When installing the curtain airbag module, install a specified part at specified place.
- Be careful not to damage the curtain airbag module during removal.
- Never open the curtain airbag module before deploying it. Never reuse the deployed curtain airbag module.
- Make sure that there are no foreign matter on airbag module.

Install in the reverse order of removal.

Tightening torque:

7.5 N·m (0.76 kgf-m, 5.5 ft-lb)

C: INSPECTION

CAUTION:

Refer to “CAUTION” of “General Description” before handling the airbag module. <Ref. to AB-5, CAUTION, General Description.>

Check for the following, and replace the damaged parts with new parts. <Ref. to AB-14, CURTAIN AIRBAG MODULE, INSPECTION, Inspection Locations After a Collision.>

1) With side collision (when curtain airbag is deployed)

- Curtain airbag module assembly
- Satellite safing sensor
- Curtain airbag sensor
- Roof trim
- Front pillar upper trim
- Center pillar upper trim
- Rear quarter pillar trim
- Airbag guide A, B, C

2) When damage is found by visual check

- Assist grip
- Assist grip bracket
- Curtain airbag harness and connector on body side
- Satellite safing sensor bracket
- Satellite safing sensor cover

3) With side collision (when curtain airbag is not deployed)

Check the roof trim, pillar trim, airbag module and sensor visually, and then replace them with new parts if damaged or cracked.

Specially inspect the damage of airbag module body, mounting bracket and harness connector.

4) Without side collision (dirt and damage of cover)

Replace the corresponding part with a new part.

8. Airbag Control Module

A: REMOVAL

CAUTION:

- Do not disassemble the airbag control module.
- If the airbag control module is deformed or if the damage from water is suspected, replace the airbag control module with a new part.
- Do not drop the airbag control module.
- After removal, keep the airbag control module on a dry, clean surface away from moisture, heat and dust.

- 1) Turn the ignition switch to OFF.
- 2) Disconnect the ground cable from battery and wait for at least 20 seconds before starting work.
- 3) Remove the console box. <Ref. to EI-47, REMOVAL, Console Box.>
- 4) Center panel <Ref. to EI-48, CENTER PANEL, REMOVAL, Center Console.>
- 5) Console front panel <Ref. to EI-48, CONSOLE FRONT PANEL, REMOVAL, Center Console.>
- 6) Remove the audio.
- 7) Remove the heater duct.

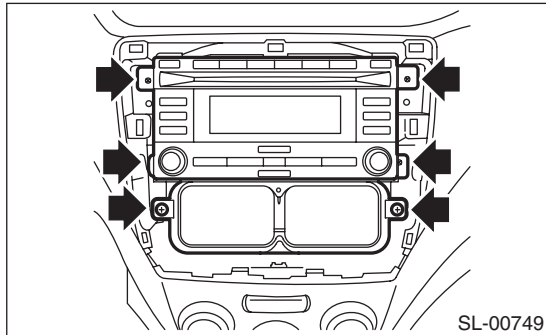

- 8) Disconnect the connector from airbag control module.
- 9) Remove the three bolts and remove airbag control module.

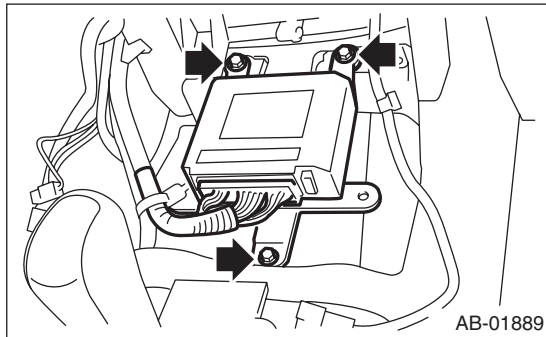

B: INSTALLATION

CAUTION:

- Do not reuse the bolt and nut. Always use new bolts and nuts for them.
 - Before installing the audio, check that the heater duct is connected securely.
- Install in the reverse order of removal.

Tightening torque:

25 N·m (2.5 kgf-m, 18.1 ft-lb)

C: INSPECTION

Check for the following, and replace the damaged parts with new parts.

- Control module, connector, and mounting bracket are damaged.
- Airbag is deployed.
- Side airbag is deployed.
- Curtain airbag is deployed.

9. Front Sub Sensor

A: REMOVAL

- 1) Turn the ignition switch to OFF.
- 2) Disconnect the ground cable from battery and wait for at least 20 seconds before starting work.
- 3) Remove the front bumper face. <Ref. to EI-29, REMOVAL, Front Bumper.>
- 4) Remove the headlight assembly. <Ref. to LI-12, REMOVAL, Headlight Assembly.>
- 5) Remove the bolt, and then detach the front sub sensor.

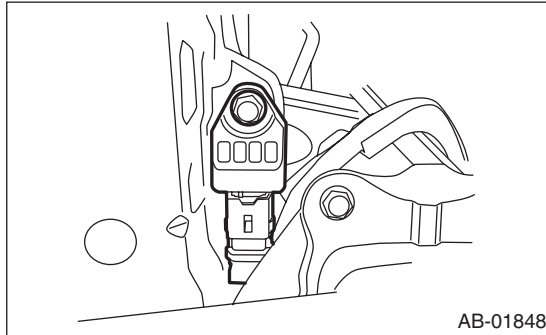

- 6) Disconnect the connector from front sub sensor.

B: INSTALLATION

Install in the reverse order of removal.

CAUTION:

- Do not reuse the bolt and nut.
Always use new bolts and nuts for them.
- When installing the sensor, securely insert the arrest pin on the back side of sensor into the body side hole.
- After attaching the headlight assembly, always perform headlight beam level adjustment.

Tightening torque:

13 N·m (1.32 kgf·m, 9.6 ft·lb)

C: INSPECTION

Check for the following, and replace the damaged parts with new parts.

- Front sub sensor or connector is damaged.
- Airbag is deployed.

10.Side Airbag Sensor

A: REMOVAL

- 1) Turn the ignition switch to OFF.
- 2) Disconnect the ground cable from battery and wait for at least 20 seconds before starting work.
- 3) Remove the front outer seat belt. <Ref. to SB-17, OUTER SEAT BELT ASSEMBLY, REMOVAL, Front Seat Belt.>
- 4) Remove the nuts to remove the side airbag sensor.

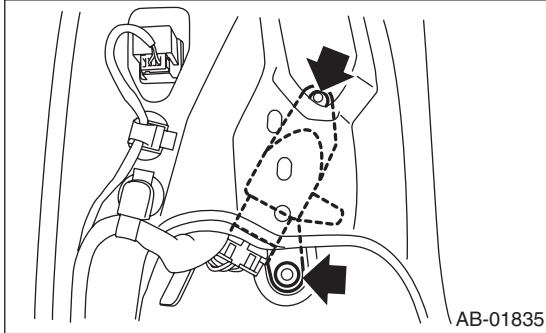

CAUTION:

Do not separate the side airbag sensor and bracket. It cause the airbag system malfunction. If the sensor is removed from the bracket, replace them with new parts.

- 5) Disconnect the airbag connector.

B: INSTALLATION

CAUTION:

- Do not reuse the bolt and nut.
- Always use new bolts and nuts for them.

Install in the reverse order of removal.

Tightening torque:

7.5 N·m (0.76 kgf·m, 5.5 ft·lb)

C: INSPECTION

Check for the following, and replace the damaged parts with new parts.

- The bracket or connector of side airbag sensor is damaged.
- Side airbag is deployed.

11. Curtain Airbag Sensor

A: REMOVAL

- 1) Turn the ignition switch to OFF.
- 2) Disconnect the ground cable from battery and wait for at least 20 seconds before starting work.
- 3) Remove the rear seat. <Ref. to SE-11, REMOVAL, Rear Seat.>
- 4) Remove the nuts to remove the curtain airbag sensor.

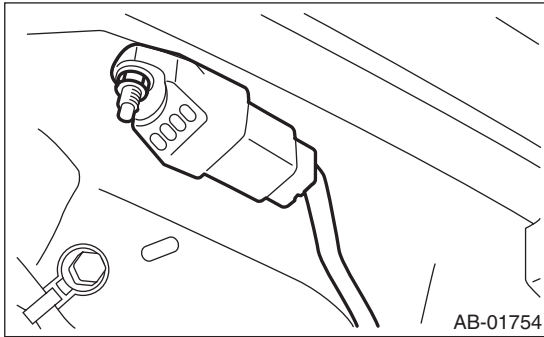

- 5) Disconnect the airbag connector.

B: INSTALLATION

CAUTION:

- Do not reuse the bolt and nut.
Always use new bolts and nuts for them.
- When installing the sensor, securely insert the arrest pin on the back side of sensor into the body side hole.

Install in the reverse order of removal.

Tightening torque:

7.5 N·m (0.76 kgf-m, 5.5 ft-lb)

C: INSPECTION

Check for the following, and replace the damaged parts with new parts.

- Curtain airbag sensor or connector is damaged.
- Curtain airbag is deployed.

12. Satellite Safing Sensor

A: REMOVAL

- 1) Turn the ignition switch to OFF.
- 2) Disconnect the ground cable from battery and wait for at least 20 seconds before starting work.
- 3) Remove the rear seat cushion. <Ref. to SE-11, REMOVAL, Rear Seat.>
- 4) Remove the cover.

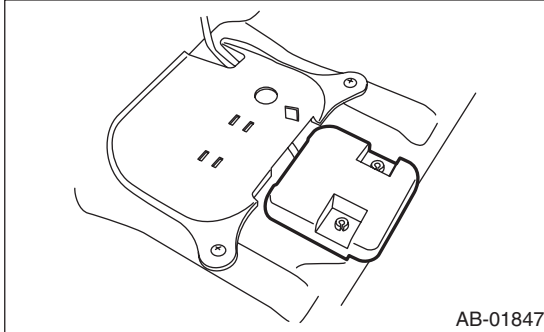

- 5) Remove the nuts to remove the satellite safing sensor.

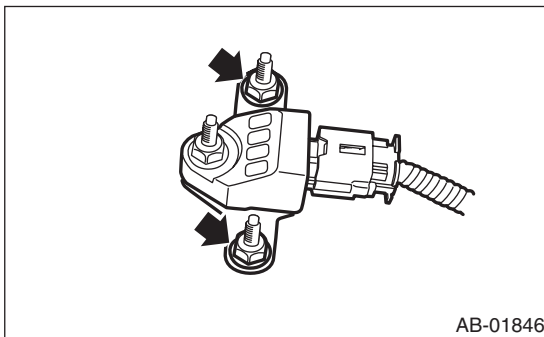

CAUTION:

Do not separate the satellite safing sensor and bracket. It cause the airbag system malfunction. If the sensor is removed from the bracket, replace them with new parts.

- 6) Disconnect the airbag connector.

B: INSTALLATION

CAUTION:

- Do not reuse the bolt and nut. Always use new bolts and nuts for them.
- When installing the satellite safing sensor cover, push the cover securely until it contacts the floor panel.
- When the installation of the satellite safing sensor cover becomes loose and it can be removed easily, replace the cover with a new part.
- After installing the satellite safing sensor cover, check that the sensor harness is not pinched.

Install in the reverse order of removal.

Tightening torque:

7.5 N·m (0.76 kgf-m, 5.5 ft-lb)

C: INSPECTION

Check for the following, and replace the damaged parts with new parts.

- Mounting bracket or connector of satellite safing sensor is damaged.
- The satellite safing sensor cover is damaged
- Side airbag or curtain airbag is deployed.

13. Roll Connector

A: REMOVAL

- 1) Turn the ignition switch to OFF.
- 2) Disconnect the ground cable from battery and wait for at least 20 seconds before starting work.
- 3) Remove the driver's airbag module. <Ref. to AB-16, Driver's Airbag Module.>
- 4) Remove the steering wheel. <Ref. to PS-13, REMOVAL, Steering Wheel.>
- 5) Remove the steering column cover.
- 6) Remove the screws, and then remove the roll connector.

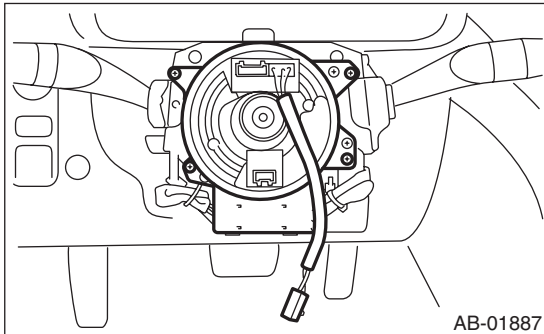

B: INSTALLATION

- 1) Install in the reverse order of removal.
- 2) Before installing steering wheel, be sure to adjust the direction of roll connector with steering. <Ref. to AB-27, ADJUSTMENT, Roll Connector.>

C: INSPECTION

Check for the following, and replace the damaged parts with new parts.

- Combination switch and roll connector are cracked or deformed.

D: ADJUSTMENT

- 1) Check that front wheels are positioned in straight ahead direction.
- 2) Turn the roll connector pin (A) clockwise until it stops.
- 3) Turn the roll connector pins (A) approx. 3.25 turns until "▲" marks are aligned.

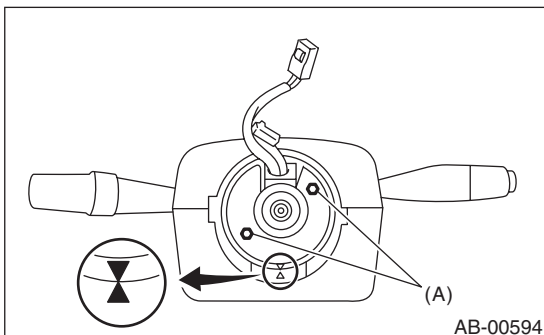

Roll Connector

AIRBAG SYSTEM

Brought to you by Eris Studios
NOT FOR RESALE