

Brought to you by Eris Studios
NOT FOR RESALE

AIRBAG SYSTEM (DIAGNOSTICS)

Basic Diagnostic Procedure

AIRBAG SYSTEM (DIAGNOSTICS)

Brought to you by Eris Studios
NOT FOR RESALE

1. Basic Diagnostic Procedure

A: PROCEDURE

	Step	Check	Yes	No
1	CHECK WARNING LIGHT. Check whether the airbag warning light in the combination meter is lit.	Does the airbag warning light illuminate?	Go to step 2.	Perform the diagnosis according to phenomenon of the problem.
2	READ DTC. 1) Turn the ignition switch to OFF. 2) Connect the Subaru Select Monitor to the data link connector. 3) Turn the ignition switch to ON and run the Subaru Select Monitor. 4) Read the DTC. <Ref. to AB(diag)-33, OPERATION, Read Diagnostic Trouble Code (DTC).> NOTE: If the communication function of the Subaru Select Monitor cannot be executed normally, check the communication circuit. <Ref. to AB(diag)-30, COMMUNICATION FOR INITIALIZING IMPOSSIBLE, INSPECTION, Subaru Select Monitor.> 5) Record all DTCs and freeze frame data.	Is DTC displayed?	Go to step 3.	Go to "Airbag Warning Light Failure". <Ref. to AB(diag)-37, Airbag Warning Light Failure.>
3	PERFORM DIAGNOSIS. 1) Judge the possible cause from "List of Diagnostic Trouble Code (DTC)". <Ref. to AB(diag)-42, List of Diagnostic Trouble Code (DTC).> 2) Inspect the DTC using "List of Diagnostic Trouble Code (DTC)". 3) Repair the trouble cause. 4) Perform the Clear Memory Mode. <Ref. to AB(diag)-35, Clear Memory Mode.> 5) Perform the Inspection Mode. <Ref. to AB(diag)-34, Inspection Mode.> 6) Read any other DTCs displayed.	Is DTC displayed?	Perform the procedure 1) to 5) in step 3.	Finish the diagnosis.

Check List for Interview

AIRBAG SYSTEM (DIAGNOSTICS)

Brought to you by Eris Studios
NOT FOR SALE

2. Check List for Interview

A: CHECK

Customer's Name		Inspector's Name	
Date Vehicle Brought in	/ /	Registration No.	
Odometer Reading	km miles	V.I.N.	
Date Problem Occurred	/ /	Registration Year	/ /
Weather	<input type="checkbox"/> Fine <input type="checkbox"/> Cloudy <input type="checkbox"/> Rainy <input type="checkbox"/> Snowy <input type="checkbox"/> Others:		
Temperature	°C (°F)		
Road Condition	<input type="checkbox"/> Flat road <input type="checkbox"/> Uphill <input type="checkbox"/> Downhill <input type="checkbox"/> Gravel road <input type="checkbox"/> Others:		
Vehicle Operation	<input type="checkbox"/> Starting <input type="checkbox"/> Idling <input type="checkbox"/> Driving <ul style="list-style-type: none"> <input type="checkbox"/> Constant speed <input type="checkbox"/> Accelerating <input type="checkbox"/> Decelerating <input type="checkbox"/> Turning <input type="checkbox"/> Others: 		
Details of Problem			
Airbag Warning Light Operation	<input type="checkbox"/> Normal (After turning the ignition switch to ON, lit for approximately 6 seconds and goes off.) <input type="checkbox"/> Remains ON <input type="checkbox"/> Remains OFF		
DTC output	<input type="checkbox"/> OK code <input type="checkbox"/> DTC: (Code:)		

General Description

AIRBAG SYSTEM (DIAGNOSTICS)

Brought to you by Eris Studios
NOT FOR RESALE

3. General Description

A: CAUTION

- When servicing a vehicle, be sure to turn the ignition switch to OFF, disconnect the ground cable from battery, and wait for 20 seconds or more before starting work.
- The airbag system is fitted with a backup power source. If the airbag system is serviced within 20 seconds after the ground cable is disconnected, it may inflate.

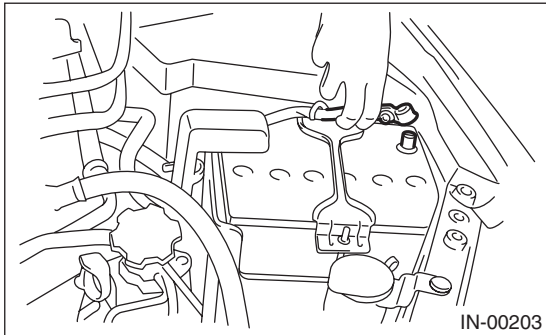

- If sensors, airbag module, airbag control module, pretensioner or harness is deformed or damaged, replace with new parts.

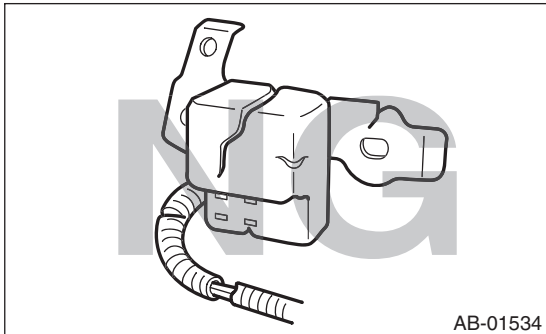

- Do not use the airbag system and pretensioners on other vehicles. When replacing parts, be sure to replace them with new parts.
- When checking the airbag system, be sure to use a digital circuit tester. Use of an analog circuit tester may cause the airbag to activate erroneously due to a minimal current inside tester.

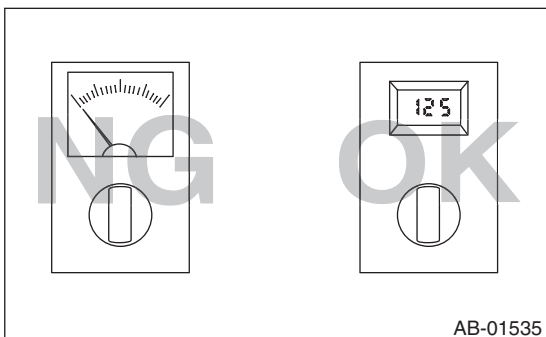

- When checking, use a test harness (1). Damage to connector terminal causes malfunction. Do not directly put the tester probe on airbag connector terminal.

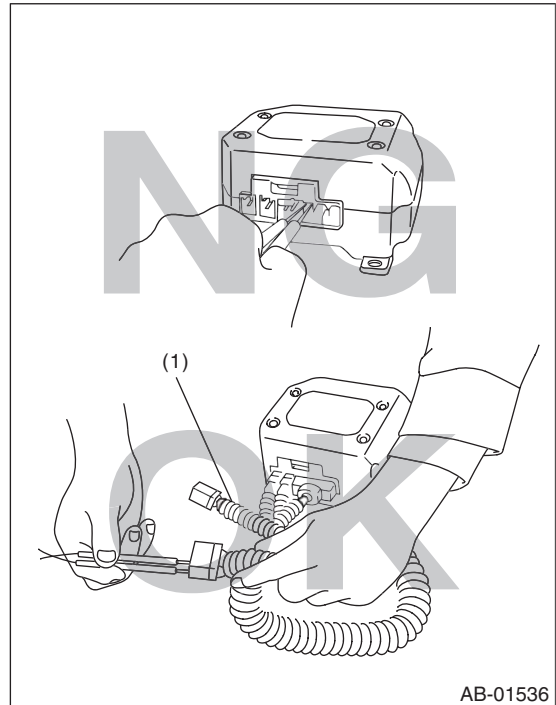

- Do not drop the airbag system parts, or keep them at high temperature of 85°C (153°F) or more, or let water, oil or grease get on them; the internal parts may be damaged and reliability greatly lowered.

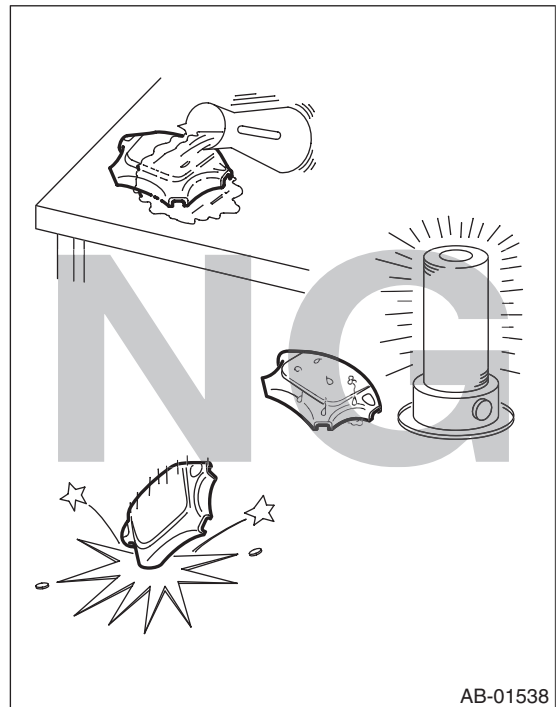

General Description

AIRBAG SYSTEM (DIAGNOSTICS)

Brought to you by Eris Studios
NOT FOR SALE

- If damage, open circuit or rust is found on airbag system wiring harness, do not use a soldering equipment to repair. Replace the faulty harness with a new genuine part.

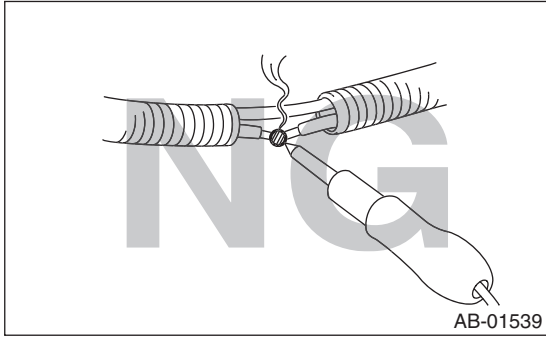

- Install the wiring harness securely with the specified clips to avoid interference or tangled with other parts.

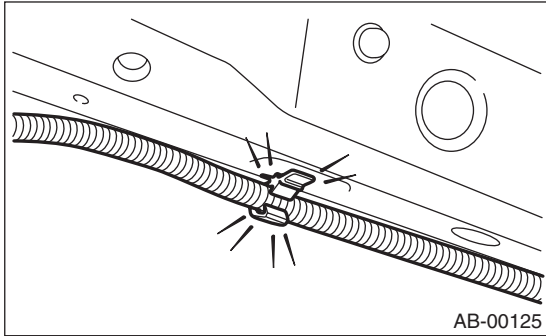

- Do not allow water or oil to come in contact with the connector terminals. Also, do not touch the connector terminals.

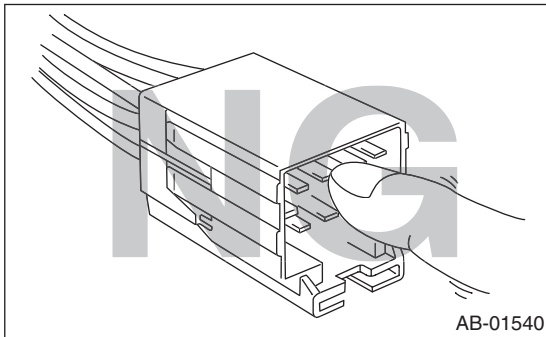

- Do not disassemble driver's airbag module, passenger's airbag module, side or curtain airbag modules, or pretensioner.

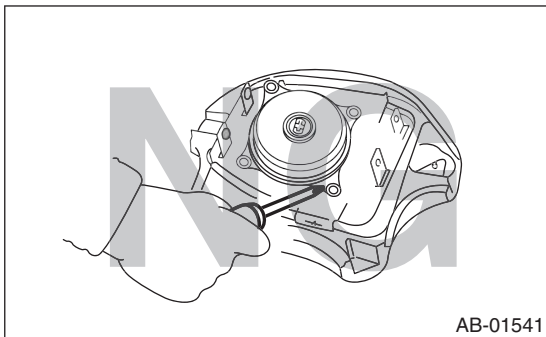

- The airbag module cannot be used again if deployed once.
- After removal, keep the airbag module with the pad side facing upward on a dry, clean and flat surface away from heat, light sources, moisture and dust.

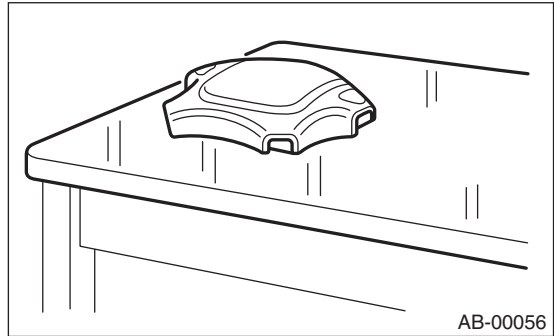

- Do not check continuity of the airbag modules for driver's side, passenger's side and curtain, or the pretensioner.

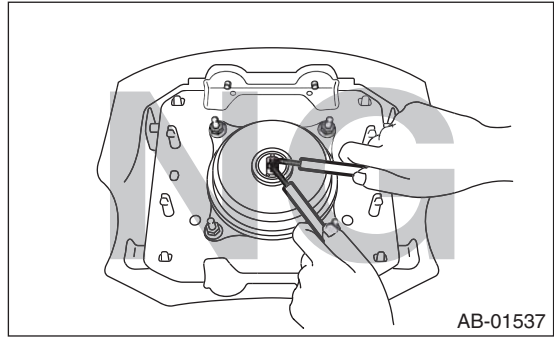

- The removed front seat with airbag module must be kept at least 200 mm (8 in) away from walls and other objects.

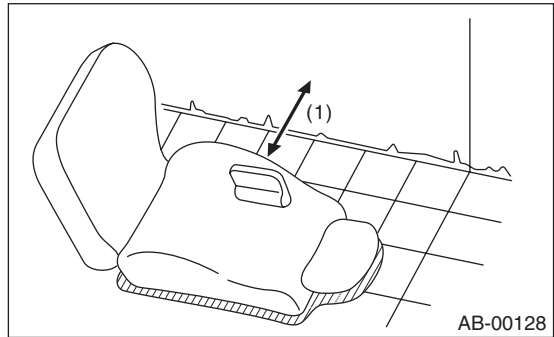

(1) 200 mm (8 in) or more

- When painting or performing sheet metal work on the front part of the vehicle, including the front wheel apron, front fender and front side frame, remove the front sub sensors and wiring harness of airbag system.

General Description

AIRBAG SYSTEM (DIAGNOSTICS)

Brought to you by Eris Studios
NOT FOR RESALE

- When painting or repairing sheet metal work on the side of the vehicle, including the side sill, center pillar, front and rear doors, rear crossmember and rear floorpan, remove the side airbag sensors, satellite safing sensor and wiring harness of the airbag system.

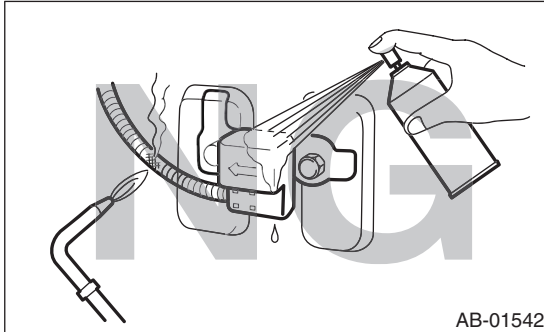

- Do not discard undeployed airbag module. They could easily cause a serious accident if accidentally deployed.

General Description

AIRBAG SYSTEM (DIAGNOSTICS)

Brought to you by Eris Studios
NOT FOR RESALE

- When storing a removed airbag module, do not place it with the pad side facing downward. Do not place any objects on the airbag module. Do not pile up the airbag module. If the airbag inflates for some reason when an airbag module pad is touching other objects, it may cause serious accident.

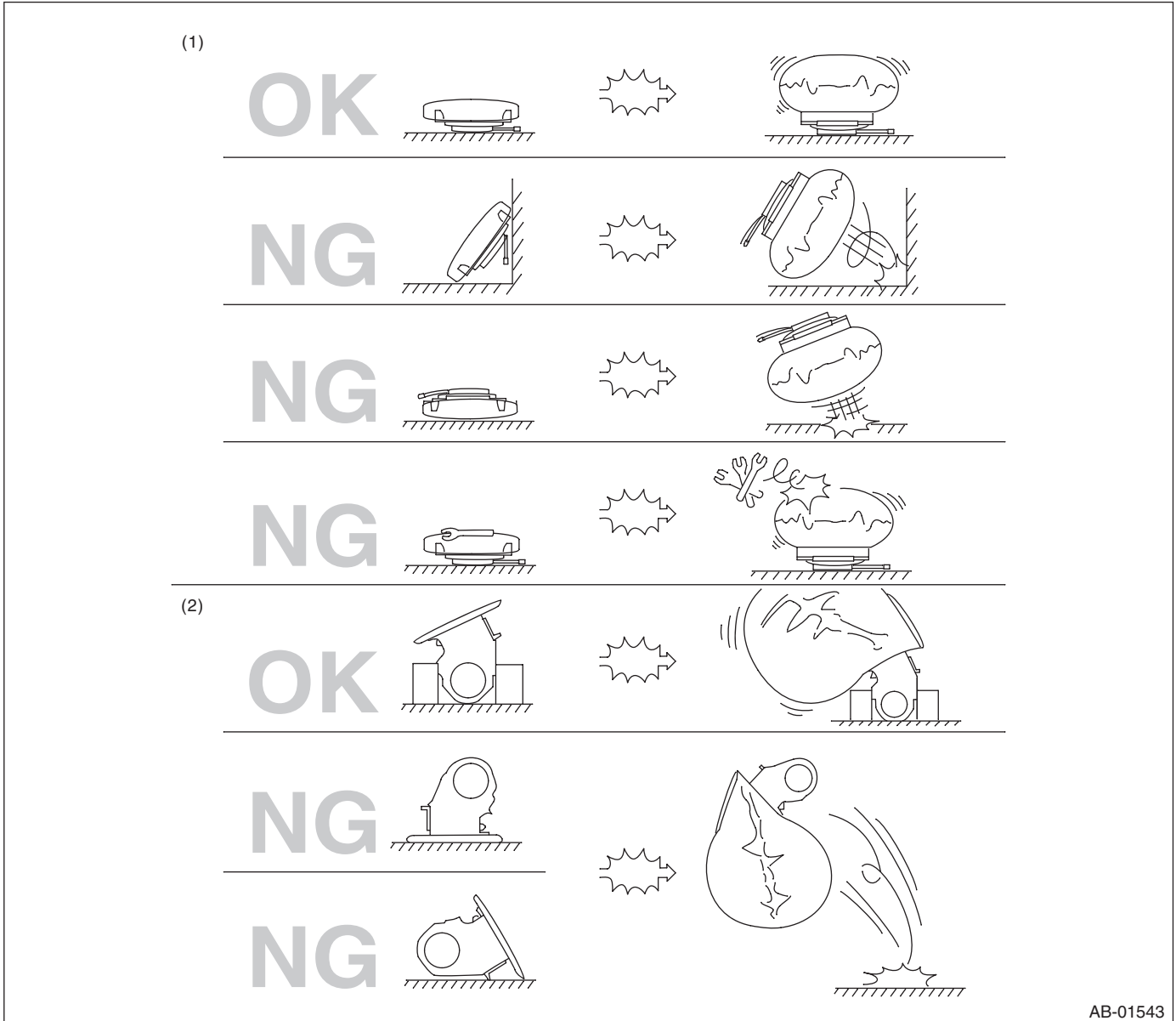

AB-01543

(1) Driver's airbag module

(2) Passenger's airbag module

B: INSPECTION

Measure the battery voltage and check electrolyte.

Standard voltage: 12 V

Specific gravity: 1.260 or more

General Description

AIRBAG SYSTEM (DIAGNOSTICS)

Brought to you by Eris Studios
NOT FOR RESALE

C: PREPARATION TOOL

CAUTION:

To measure the voltage and resistance of airbag system component, be sure to use the specified test harness.

1. SPECIAL TOOL

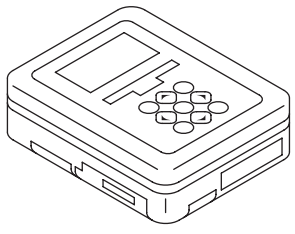
ILLUSTRATION	TOOL NUMBER	DESCRIPTION	REMARKS
 <p>ST1B021XU0</p>	1B021XU0	SUBARU SELECT MONITOR III KIT	Used for troubleshooting for electrical system.

• TEST HARNESS H

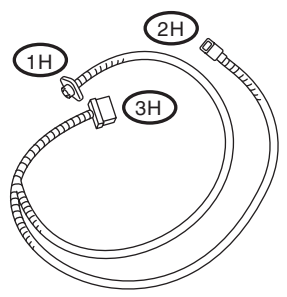
ILLUSTRATION	TOOL NUMBER	DESCRIPTION	REMARKS
 <p>ST98299FA030</p>	98299FA030	TEST HARNESS H	Used when measuring voltage and resistance of front sub sensor and satellite safing sensor.

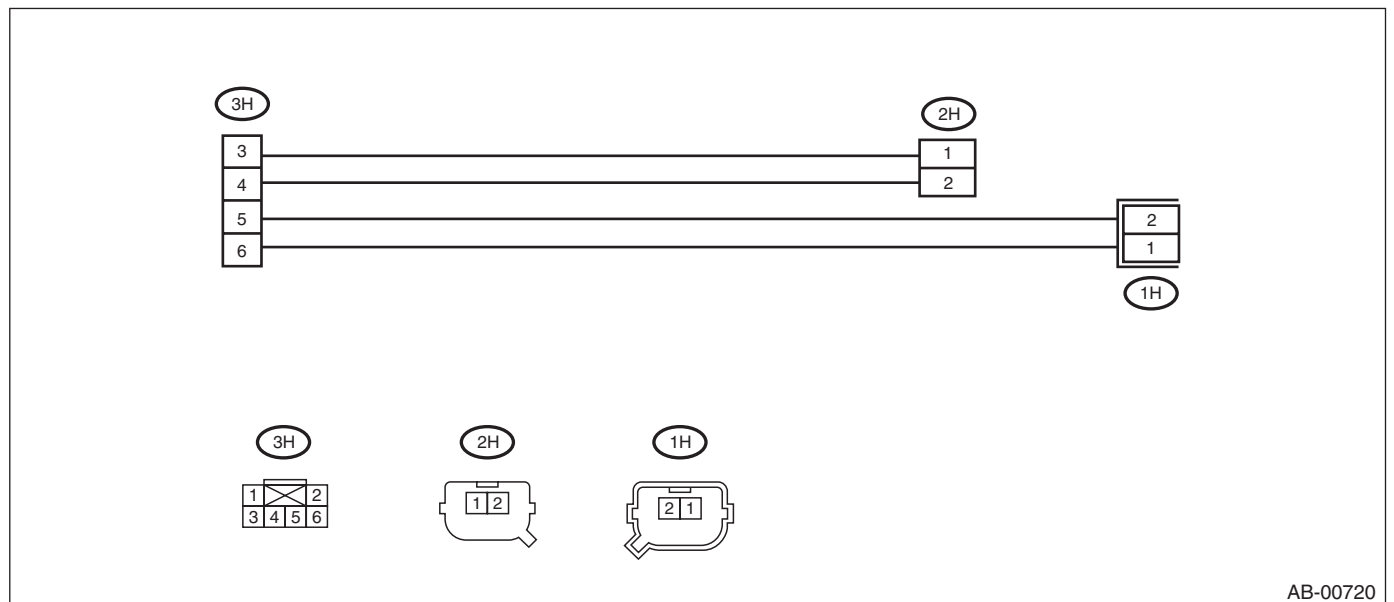

AB-00720

General Description

AIRBAG SYSTEM (DIAGNOSTICS)

Brought to you by Eris Studios
NOT FOR SALE

• TEST HARNESS N

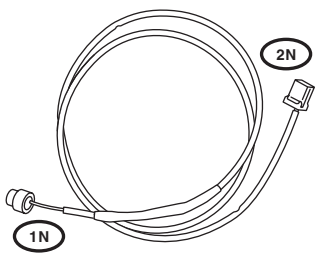
ILLUSTRATION	TOOL NUMBER	DESCRIPTION	REMARKS
 <p>ST98299SA000</p>	98299SA000	TEST HARNESS N	Used when measuring voltage and resistance of driver's airbag module and seat belt pretensioner.

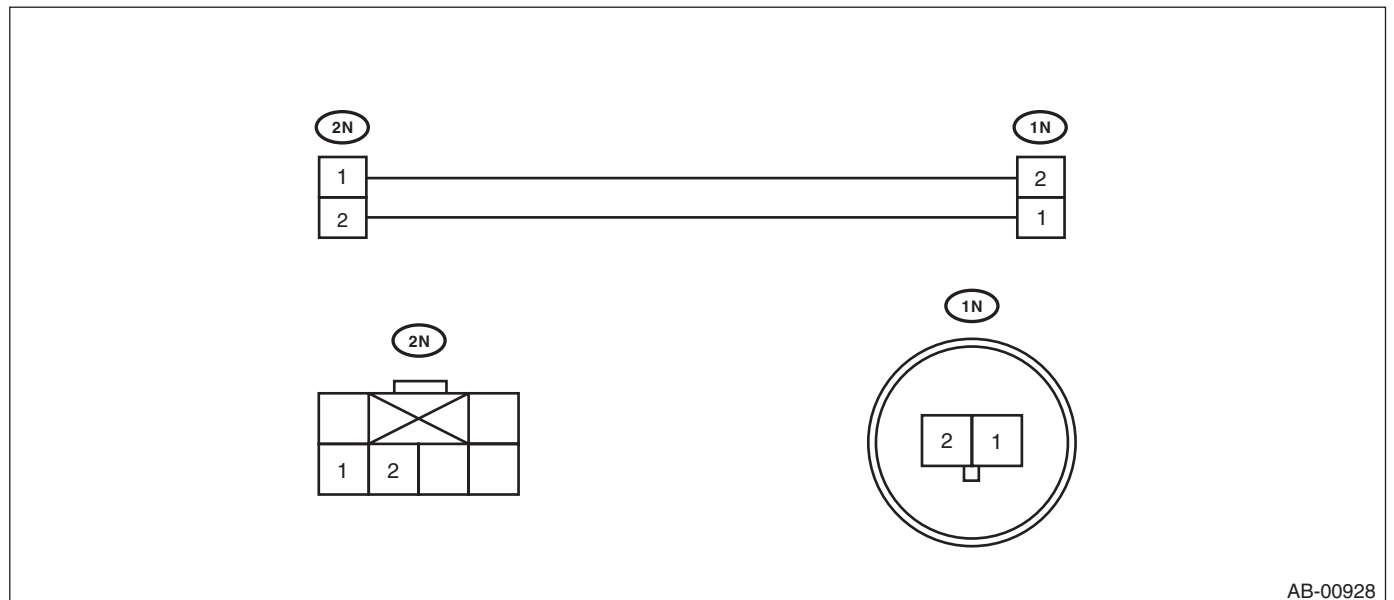

AB-00928

General Description

Brought to you by Eris Studios
NOT FOR RESALE

AIRBAG SYSTEM (DIAGNOSTICS)

- TEST HARNESS P

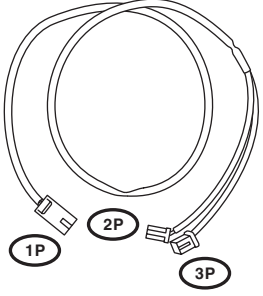
ILLUSTRATION	TOOL NUMBER	DESCRIPTION	REMARKS
 <p>ST98299SA020</p>	98299SA020	TEST HARNESS P	Used when measuring voltage and resistance of driver's airbag module harness.

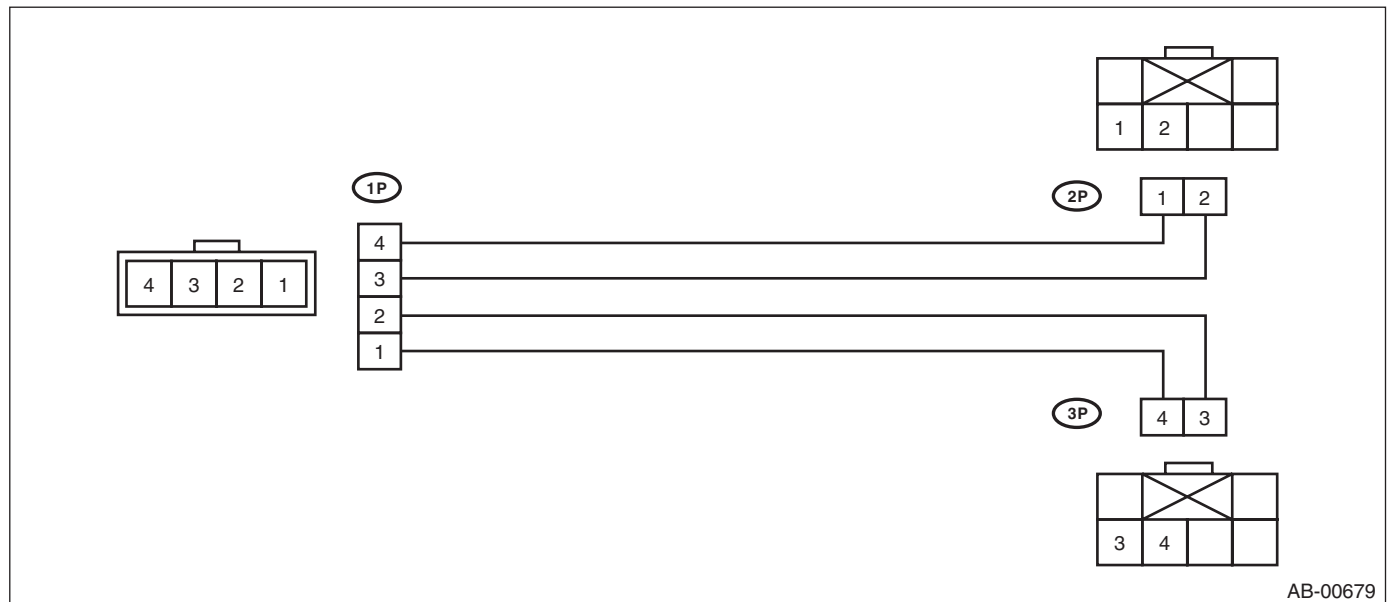

General Description

AIRBAG SYSTEM (DIAGNOSTICS)

Brought to you by Eris Studios
NOT FOR SALE

- TEST HARNESS Q

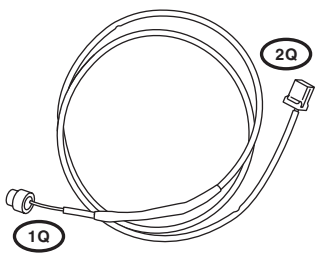
ILLUSTRATION	TOOL NUMBER	DESCRIPTION	REMARKS
 <p>ST98299SA040</p>	98299SA040	TEST HARNESS Q	Used when measuring voltage and resistance of driver's airbag module.

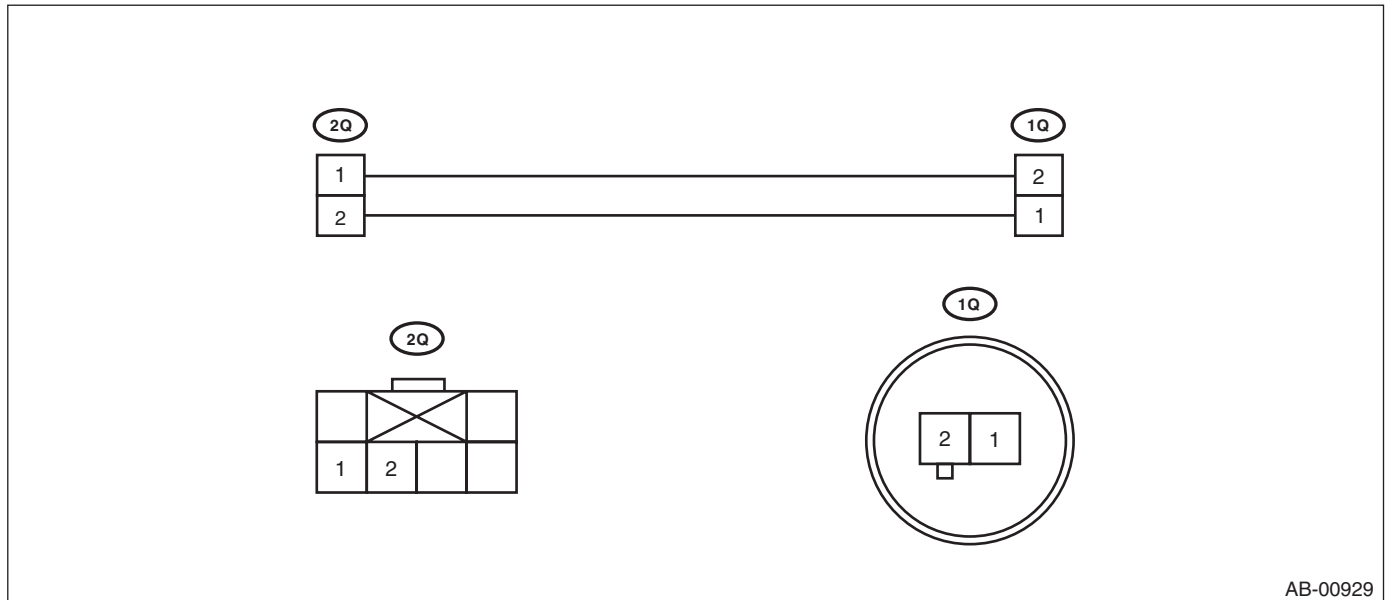

AB-00929

General Description

Brought to you by Eris Studios
NOT FOR RESALE

AIRBAG SYSTEM (DIAGNOSTICS)

- TEST HARNESS AG

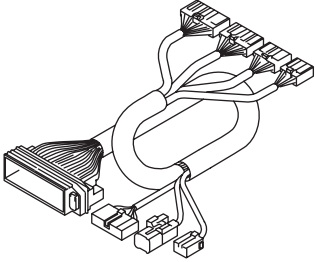
ILLUSTRATION	TOOL NUMBER	DESCRIPTION	REMARKS
 <p>ST98299AG070</p>	98299AG070	TEST HARNESS AG	Used when measuring voltage and resistance of airbag control module.

General Description

AIRBAG SYSTEM (DIAGNOSTICS)

Brought to you by Eris Studios
NOT FOR SALE

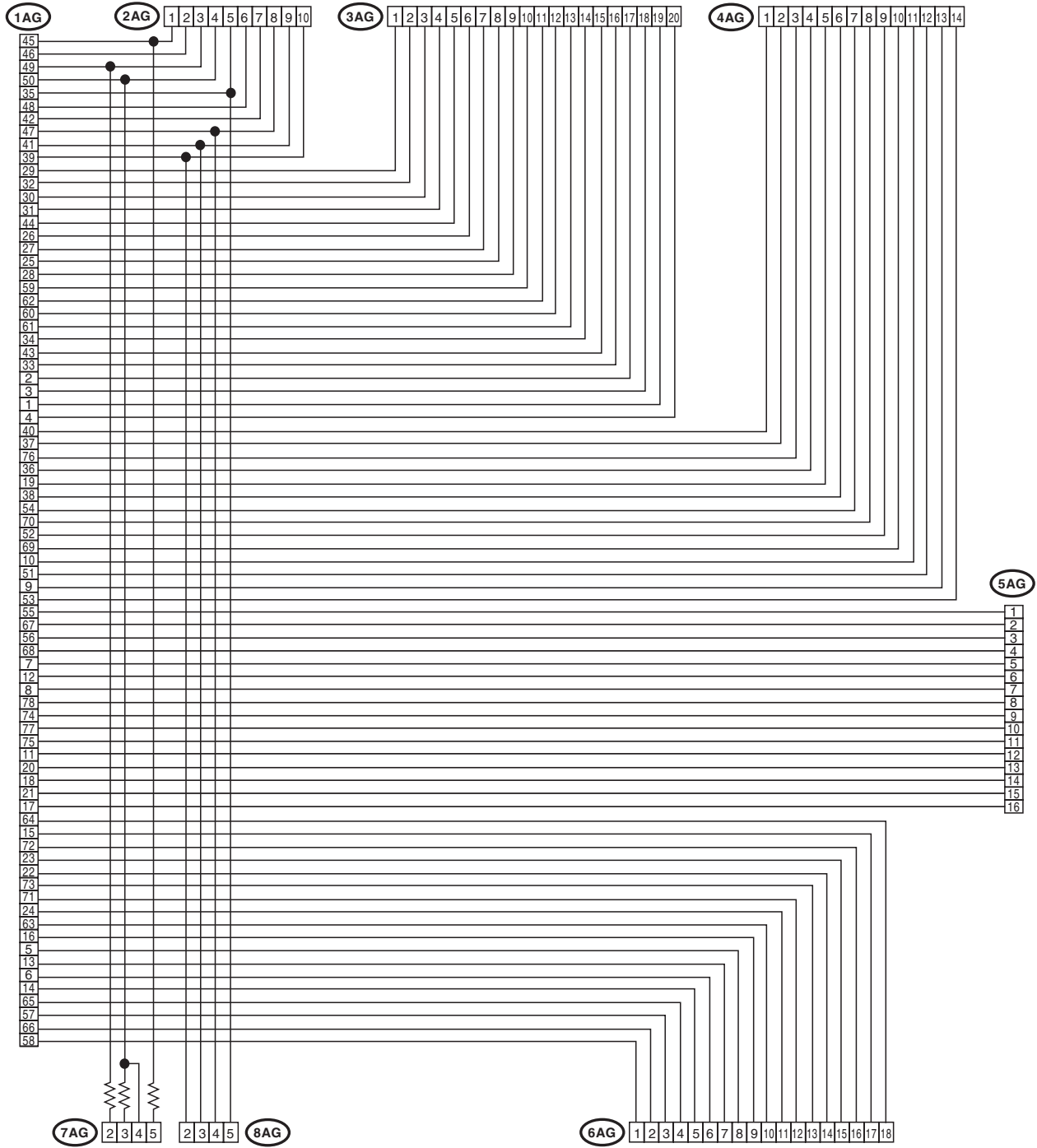

AB-01902

General Description

Brought to you by Eris Studios
NOT FOR RESALE

AIRBAG SYSTEM (DIAGNOSTICS)

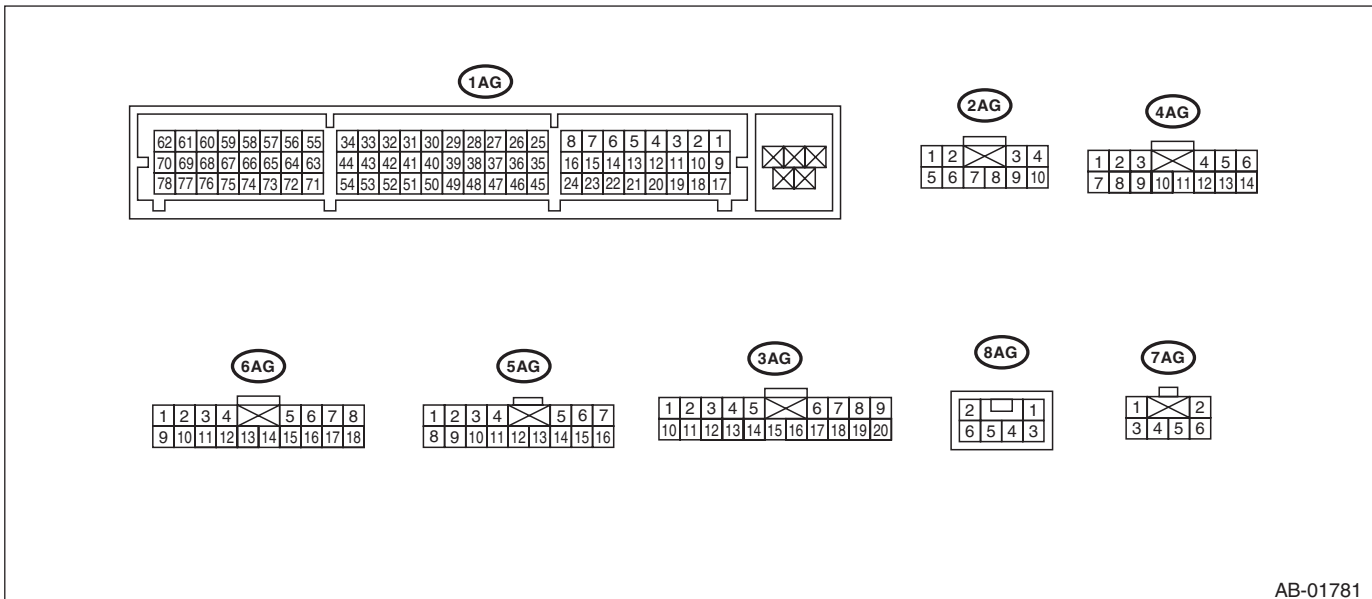

AB-01781

• TEST HARNESS AJ

ILLUSTRATION	TOOL NUMBER	DESCRIPTION	REMARKS
<p>ST98299FG000</p>	98299FG000	TEST HARNESS AJ	Used when measuring power supply and resistance of side airbag harness.

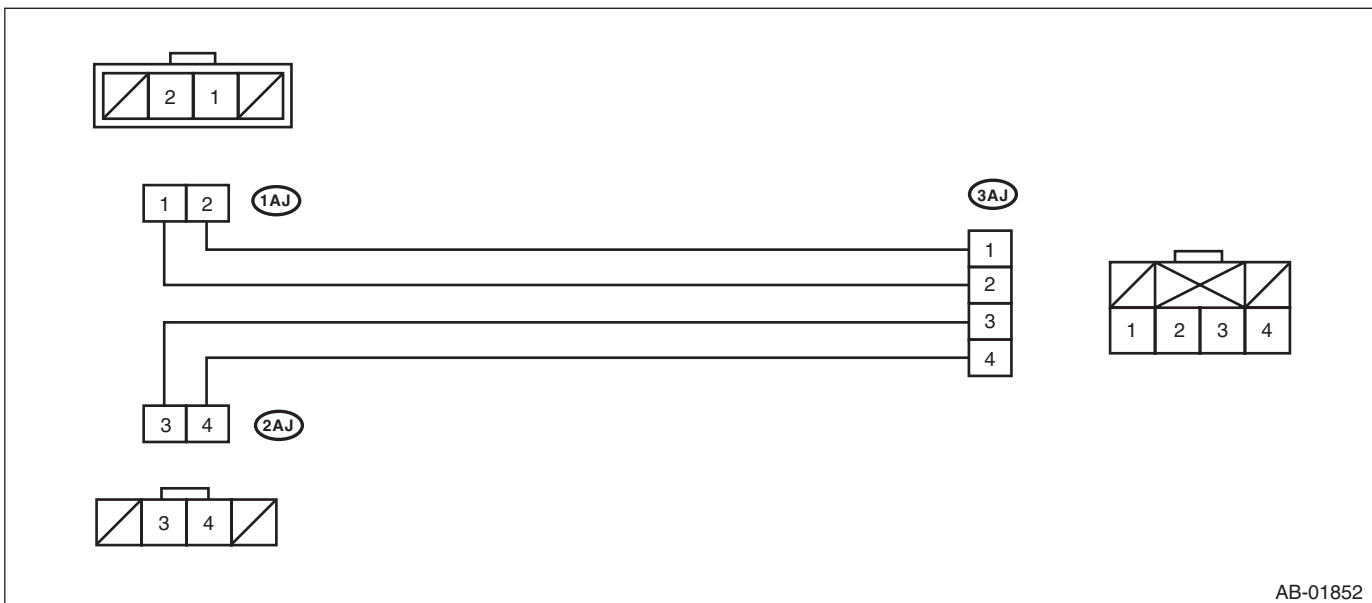

AB-01852

General Description

AIRBAG SYSTEM (DIAGNOSTICS)

Brought to you by Eris Studios
NOT FOR SALE

- TEST HARNESS V

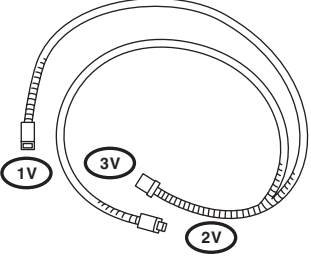
ILLUSTRATION	TOOL NUMBER	DESCRIPTION	REMARKS
 <p>ST98299AG010</p>	98299AG010	TEST HARNESS V	Used when measuring voltage and resistance of side airbag sensor and curtain airbag sensor.

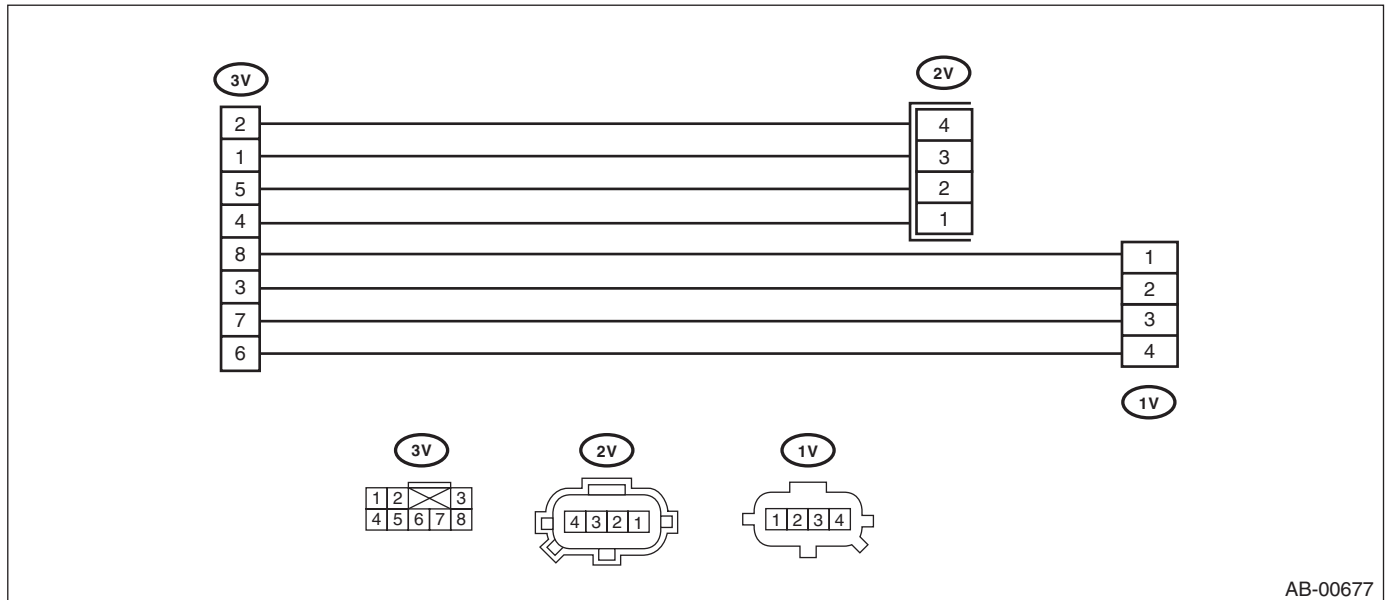

General Description

Brought to you by Eris Studios
NOT FOR RESALE

AIRBAG SYSTEM (DIAGNOSTICS)

- TEST HARNESS AB

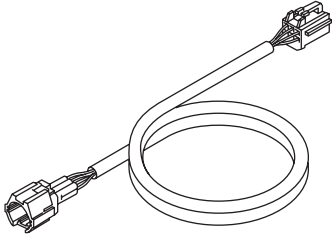
ILLUSTRATION	TOOL NUMBER	DESCRIPTION	REMARKS
 <p>ST98299XA000</p>	98299XA000	TEST HARNESS AB	Used when measuring voltage and resistance of occupant detection system.

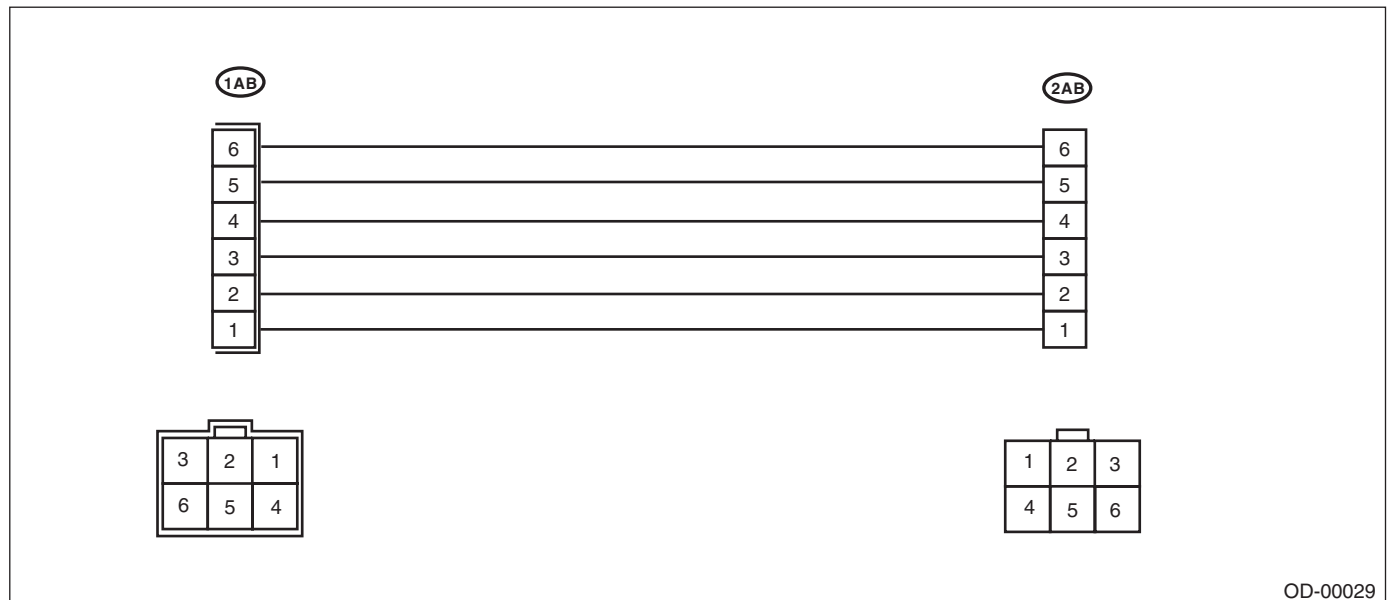

General Description

AIRBAG SYSTEM (DIAGNOSTICS)

Brought to you by Eris Studios
NOT FOR SALE

- TEST HARNESS AC

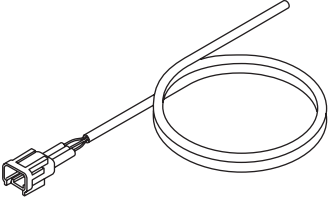
ILLUSTRATION	TOOL NUMBER	DESCRIPTION	REMARKS
 ST98299XA010	98299XA010	TEST HARNESS AC	Used for diagnosing seat belt tension sensor.

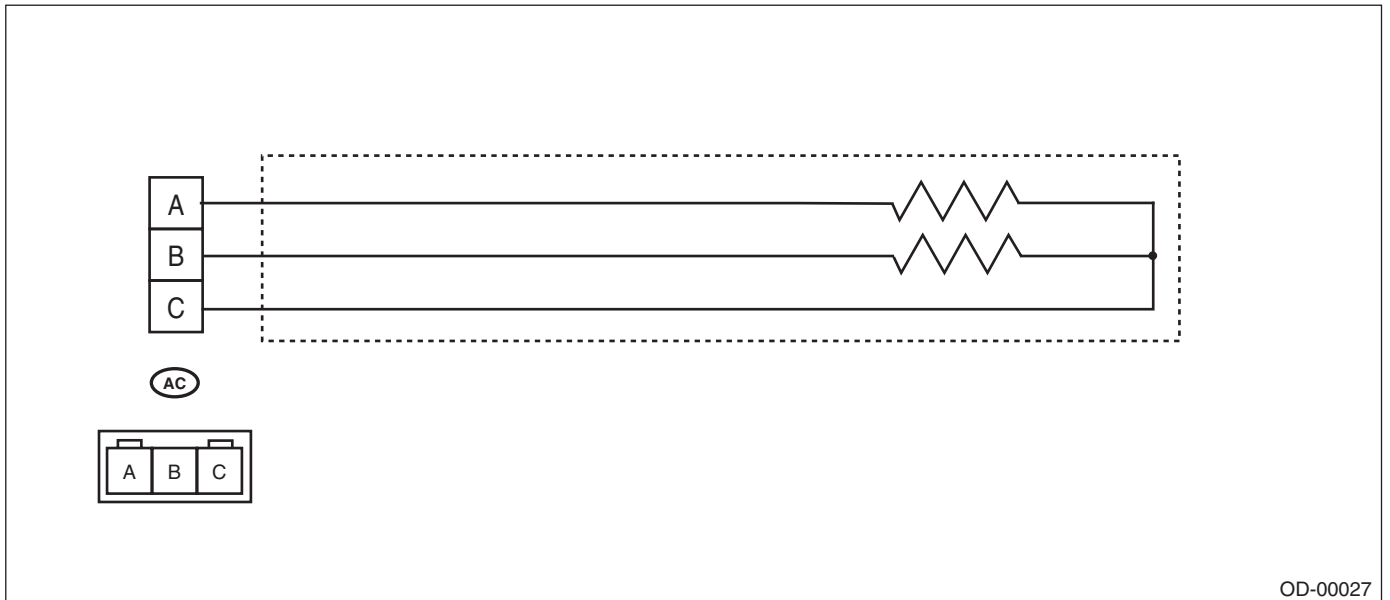

General Description

Brought to you by Eris Studios
NOT FOR RESALE

AIRBAG SYSTEM (DIAGNOSTICS)

- TEST HARNESS AD

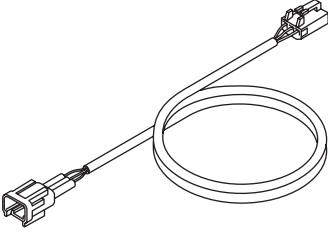
ILLUSTRATION	TOOL NUMBER	DESCRIPTION	REMARKS
 ST98299XA020	98299XA020	TEST HARNESS AD	Used when measuring voltage and resistance of the seat belt tension sensor.

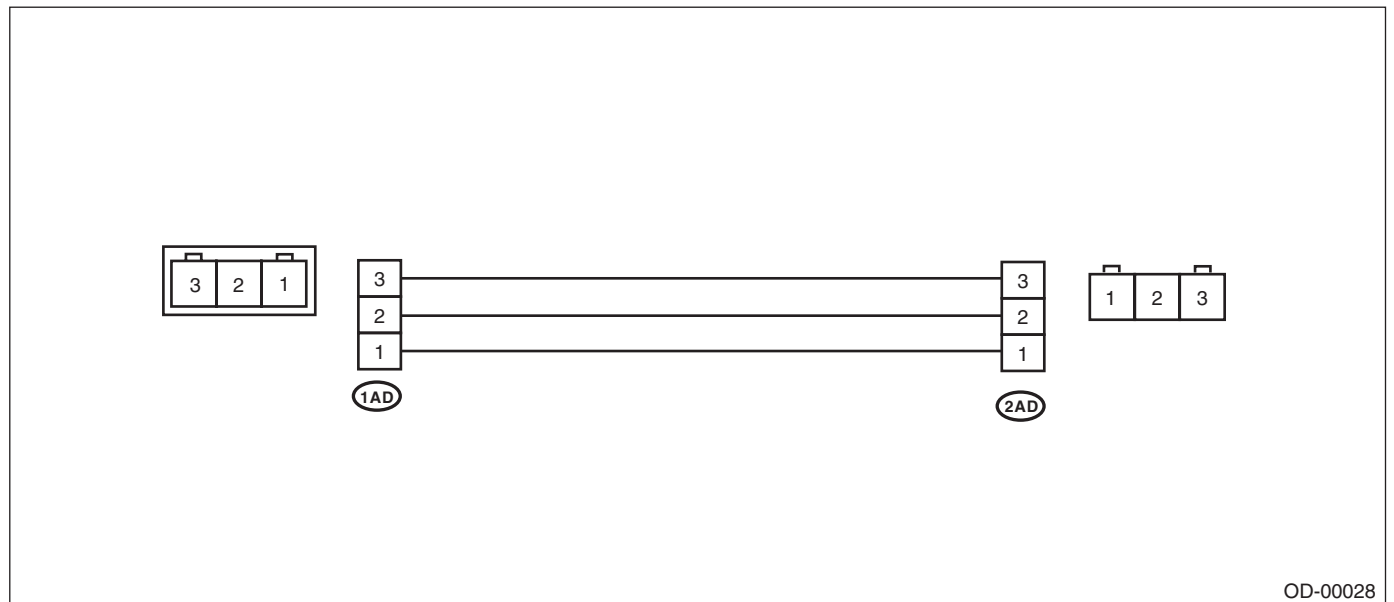

OD-00028

General Description

AIRBAG SYSTEM (DIAGNOSTICS)

Brought to you by Eris Studios
NOT FOR SALE

• TEST HARNESS AE

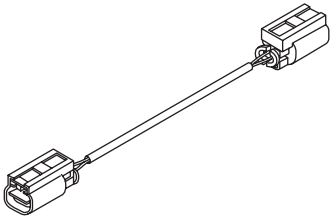
ILLUSTRATION	TOOL NUMBER	DESCRIPTION	REMARKS
 ST98299XA030	98299XA030	TEST HARNESS AE	<ul style="list-style-type: none">• Used for diagnosing seat belt tension sensor.• Used together with the test harness Y.

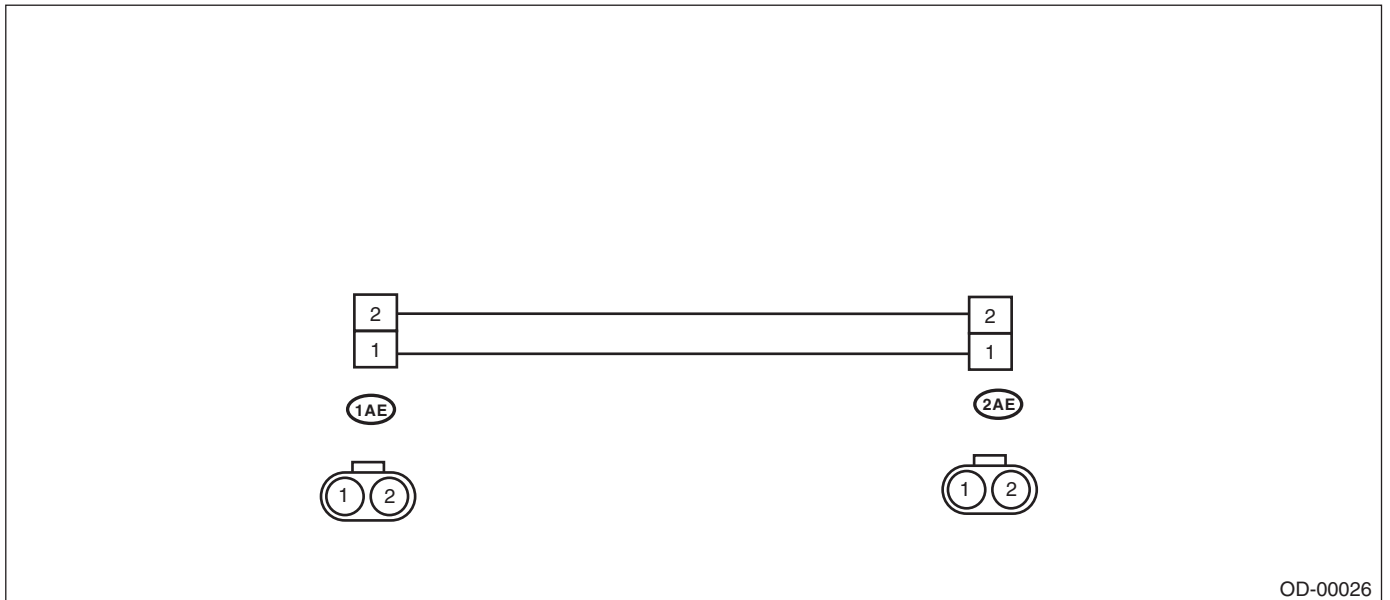

General Description

Brought to you by Eris Studios
NOT FOR RESALE

AIRBAG SYSTEM (DIAGNOSTICS)

• AIRBAG RESISTOR

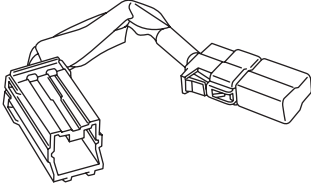
ILLUSTRATION	TOOL NUMBER	DESCRIPTION	REMARKS
 ST98299PA040	98299PA040	AIRBAG RESISTOR	Used in replacement of airbag module for which resistance value is same as airbag module. Two ST are required for diagnosis of two-stage inflator type airbag module.

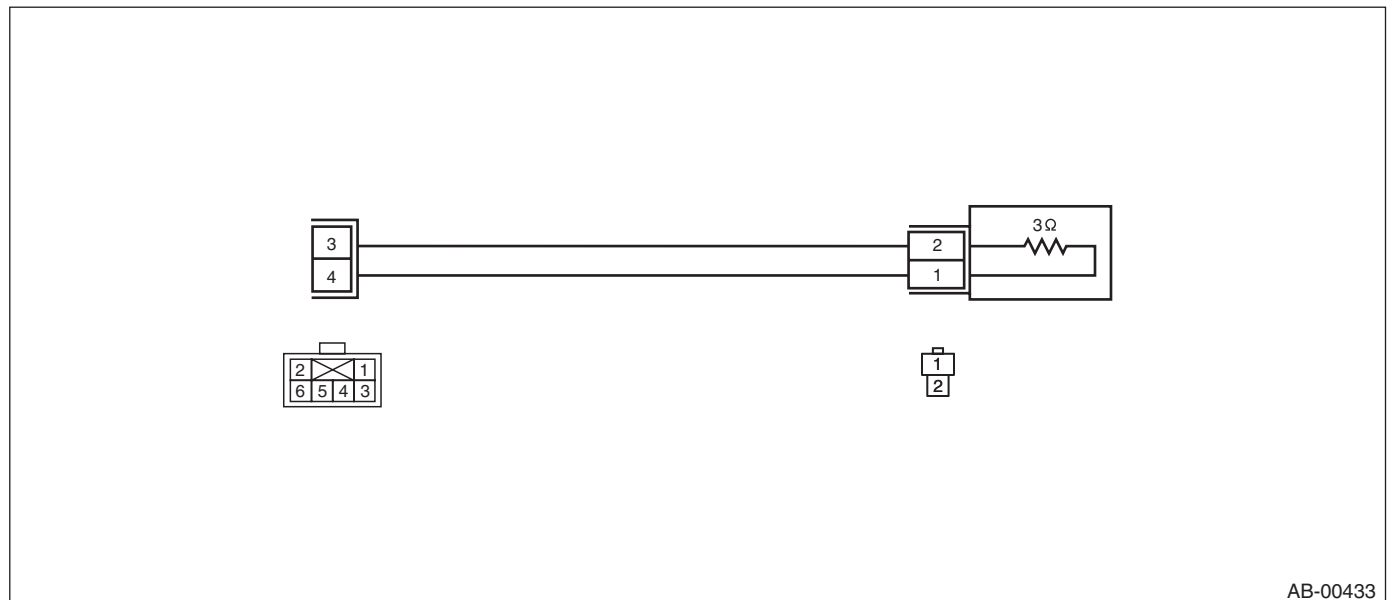

General Description

AIRBAG SYSTEM (DIAGNOSTICS)

Brought to you by Eris Studios
NOT FOR SALE

• TEST HARNESS AI

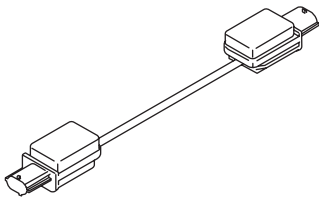
ILLUSTRATION	TOOL NUMBER	DESCRIPTION	REMARKS
 <p>ST98299AG090</p>	98299AG090	TEST HARNESS AI	<ul style="list-style-type: none"> Used when diagnosing the side airbag sensor and curtain airbag sensor. Used together with the test harness V.

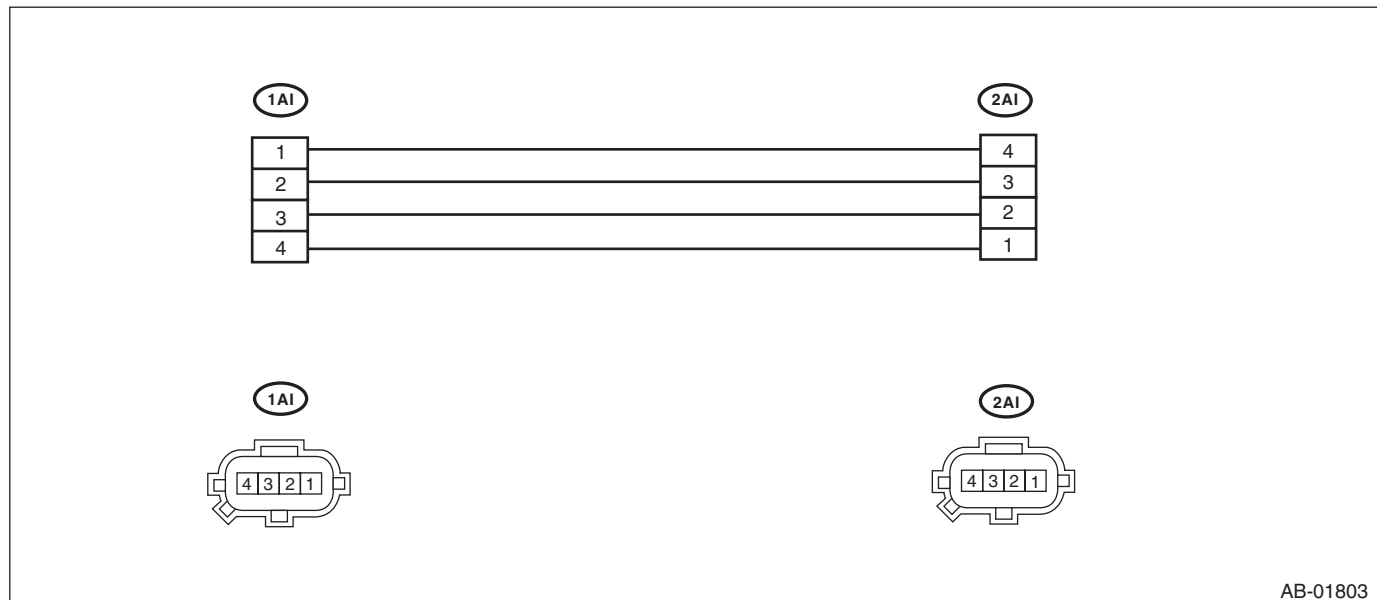

2. GENERAL TOOL

TOOL NAME	REMARKS
Circuit tester	Used for measuring resistance, voltage and current.
Oscilloscope	Used for measuring the sensor.

Electrical Component Location

AIRBAG SYSTEM (DIAGNOSTICS)

Brought to you by Eris Studios
NOT FOR RESALE

4. Electrical Component Location

A: LOCATION

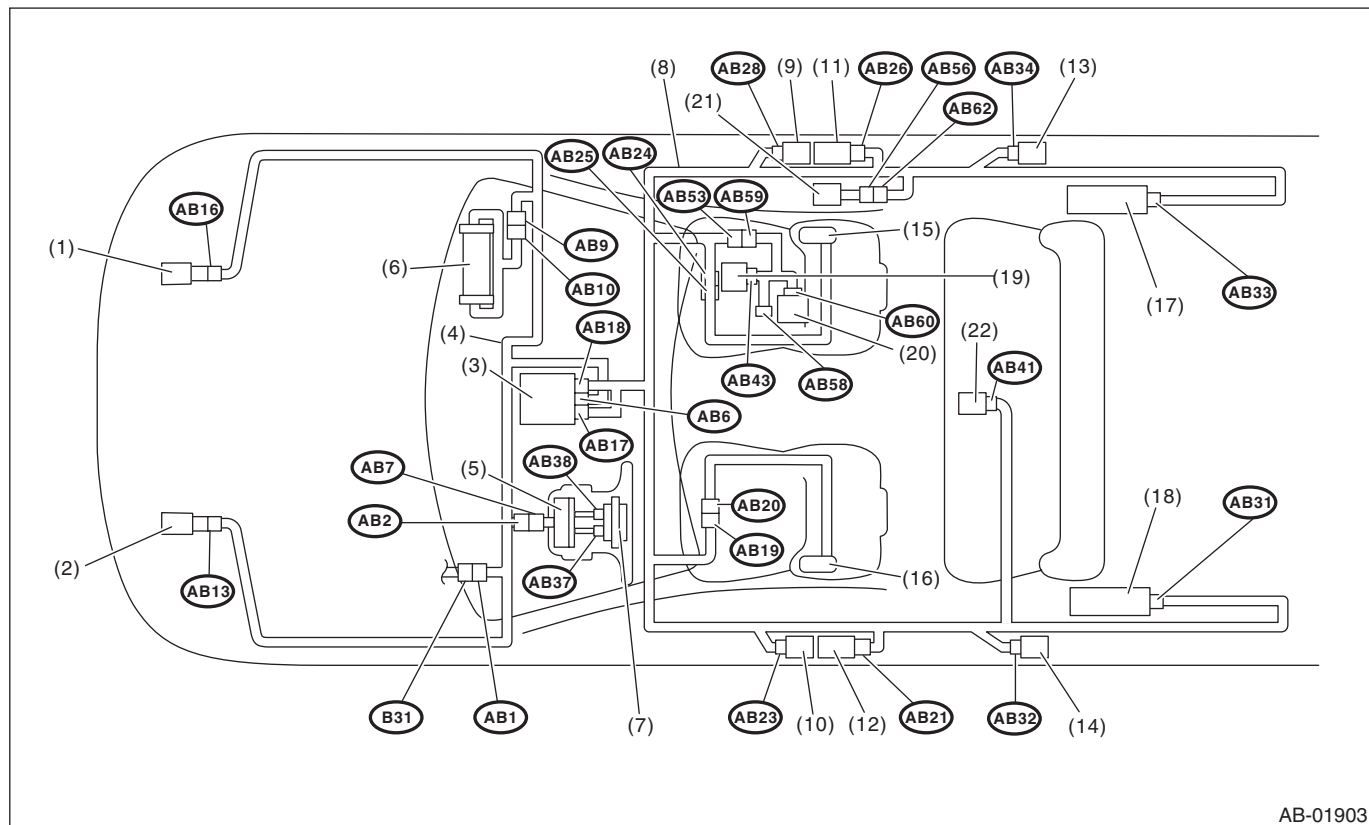

AB-01903

- | | | |
|---------------------------------|----------------------------------|----------------------------------------|
| (1) Front sub sensor (RH) | (9) Side airbag sensor (RH) | (17) Curtain airbag inflator (RH) |
| (2) Front sub sensor (LH) | (10) Side airbag sensor (LH) | (18) Curtain airbag inflator (LH) |
| (3) Airbag control module | (11) Seat belt pretensioner (RH) | (19) Occupant detection control module |
| (4) Airbag main harness | (12) Seat belt pretensioner (LH) | (20) Buckle switch (RH) |
| (5) Roll connector | (13) Curtain airbag sensor (RH) | (21) Belt tension sensor |
| (6) Passenger's airbag inflator | (14) Curtain airbag sensor (LH) | (22) Satellite safing sensor |
| (7) Driver's airbag inflator | (15) Side airbag inflator (RH) | |
| (8) Airbag rear harness | (16) Side airbag inflator (LH) | |

Connector No.	(AB1)	(AB2)	(AB6)	(AB7)	(AB9)	(AB10)	(AB13)	(AB16)	(AB17)	(AB18)	(AB19)	(AB20)
Pin	6	4	30	4	4	4	2	2	20	20	2	2
Color	Yellow	Yellow	Yellow	Yellow	Yellow	Yellow	Yellow	Yellow	Yellow	Yellow	Yellow	Yellow
Male/Female	Female	Female	Female	Male	Female	Male	Female	Female	Female	Female	Female	Male
Connector No.	(AB21)	(AB23)	(AB24)	(AB25)	(AB26)	(AB28)	(AB31)	(AB32)	(AB33)	(AB34)	(AB37)	(AB38)
Pin	2	4	2	2	2	4	2	4	2	4	2	2
Color	Black	Yellow	Yellow	Yellow	Black	Yellow	Black	Yellow	Black	Yellow	Orange	Black
Male/Female	Female	Female	Female	Male	Female	Female	Female	Female	Female	Female	Female	Female
Connector No.	(AB41)	(AB43)	(AB53)	(AB56)	(AB58)	(AB59)	(AB60)	(AB62)				
Pin	2	18	6	3	3	6	2	3				
Color	Yellow	Black	Gray	Brown	Gray	Gray	Yellow	Brown				
Male/Female	Female	Female	Female	Male	Female	Male	Male	Female				

5. Airbag Connector

A: PROCEDURE

1. AIRBAG CONTROL MODULE

1) How to disconnect:

Press the lock lever plate (A) and pull out the lock lever.

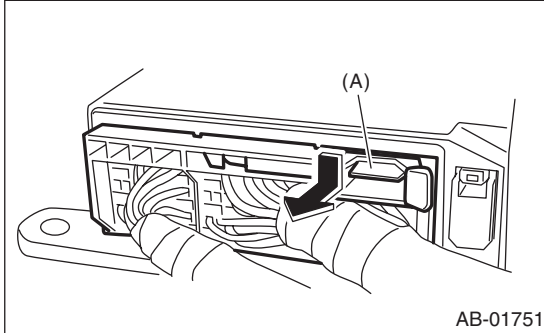

2) How to connect:

Insert the connector, push the lock lever in securely.

CAUTION:

Be sure to insert the connector in until it is locked. Then pull it lightly to make sure that it is locked.

2. BUCKLE SWITCH

1) How to disconnect:

(1) Move the slide lock (A) in the direction of arrow.

(2) While holding the slide lock (A) in the moved position, disconnect the connector.

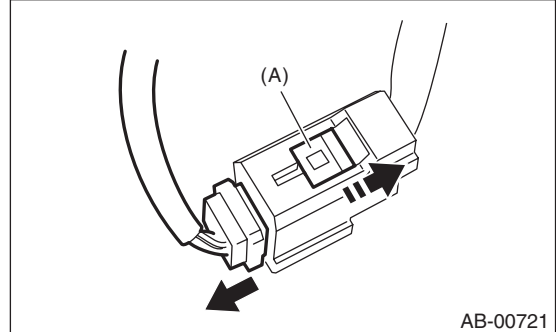

CAUTION:

When pulling the slide lock or disconnecting connector, be sure to hold the connector, not the harness.

2) How to connect:

Holding the connector (A), and push it in carefully until a clicking sound is heard.

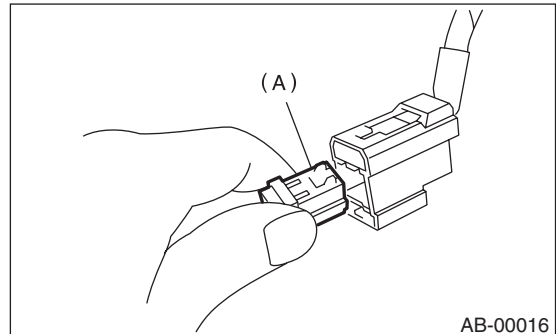

CAUTION:

Be sure to insert the connector in until it is locked. Then pull it gently to make sure that it is locked.

Airbag Connector

Brought to you by Eris Studios
NOT FOR RESALE

AIRBAG SYSTEM (DIAGNOSTICS)

3. DRIVER'S AIRBAG MODULE & PRETENSIONER & CURTAIN AIRBAG

1) How to disconnect:

(1) Using a flat tip screwdriver, pry the push lock upward to unlock.

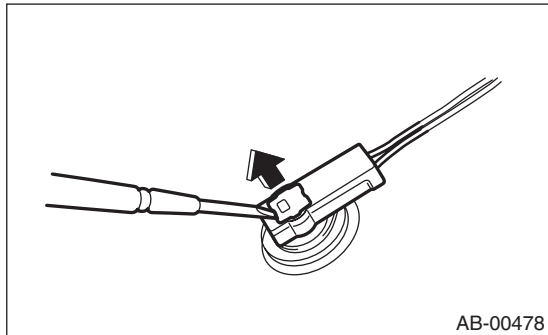

AB-00478

(2) Pull the connector to disconnect from the driver's airbag module assembly, the retractor assembly or the curtain airbag inflator.

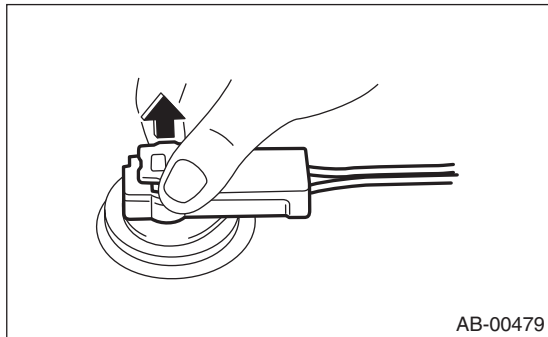

AB-00479

2) How to connect:

Connect the connector in the reverse order of disconnecting. At this time, be sure to insert the push lock until a clicking sound is heard.

CAUTION:

- Be sure to insert the connector in until it is locked. Then pull it gently to make sure that it is locked.
- Be sure to push the push lock in securely.

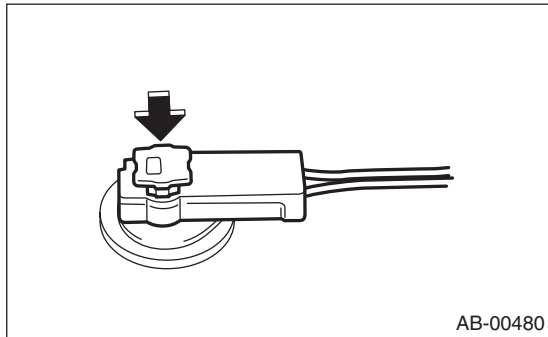

AB-00480

NOTE:

The connector cannot be connected when the push lock is in the lock position. To connect the connector, set the push lock to unlock position.

4. DRIVER'S AIRBAG (BETWEEN AIRBAG MAIN HARNESS AND ROLL CONNECTOR) AND SIDE AIRBAG

1) How to disconnect:

(1) Push the slide lock (A) in the direction of arrow.

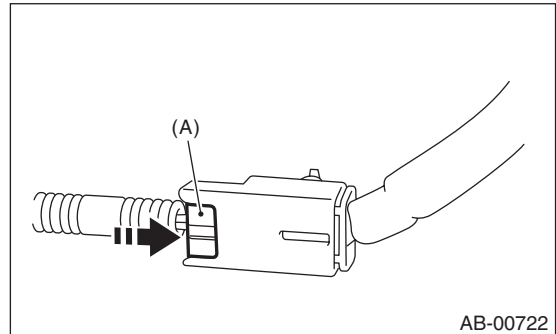

AB-00722

(2) With the slide lock pushed, disconnect the connector.

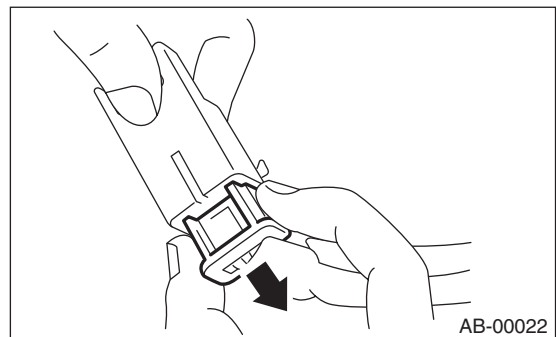

AB-00022

CAUTION:

When pulling the slide lock or disconnecting connector, be sure to hold the connector, not the harness.

2) How to connect:

Holding the connector, push it in securely until a clicking sound is heard.

CAUTION:

Be sure to insert the connector in until it is locked. Then pull it gently to make sure that it is locked.

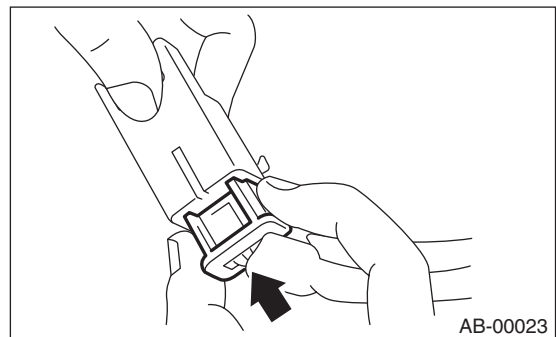

AB-00023

5. SIDE AIRBAG MODULE

1) How to disconnect:

- (1) Move the slide lock (A) in the direction of arrow and hold it.
- (2) While holding the slide lock (A), pull the connector (B) in the direction of arrow.

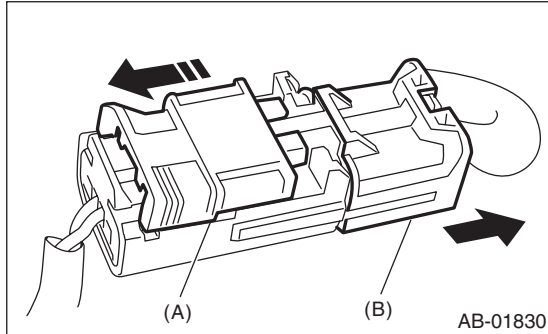

CAUTION:

When pulling the slide lock or disconnecting connector, be sure to hold the connector, not the harness.

2) How to connect:

Holding the connector, push it in securely until a clicking sound is heard.

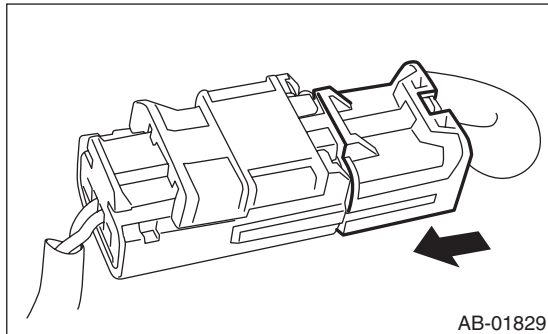

CAUTION:

Be sure to insert the connector in until it is locked. Then pull it lightly to make sure that it is locked.

6. FRONT SUB SENSOR, SIDE AIRBAG SENSOR, CURTAIN AIRBAG SENSOR AND SATELLITE SAFING SENSOR

1) How to disconnect:

Holding outer part (A), pull it in the direction of arrow.

CAUTION:

When pulling the slide lock or disconnecting connector, be sure to hold the connector, not the harness.

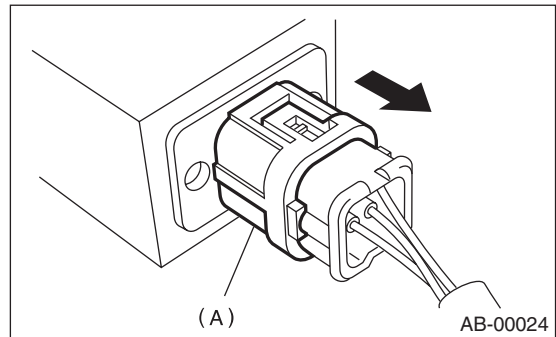

2) How to connect:

Holding the connector, push it in securely until a clicking sound is heard.

CAUTION:

- Do not touch the outer side section or else the outer side (A) will move back.
- Be sure to insert the connector in until it is locked. Then pull it gently to make sure that it is locked.

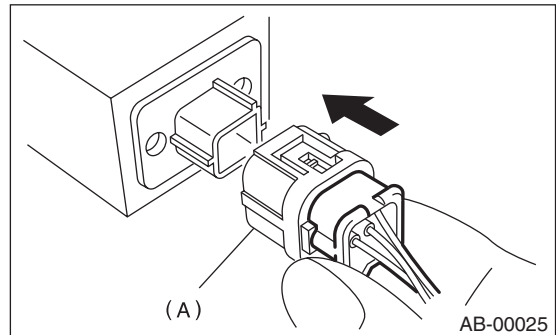

Airbag Control Module I/O Signal

AIRBAG SYSTEM (DIAGNOSTICS)

Brought to you by Eris Studios
NOT FOR RESALE

6. Airbag Control Module I/O Signal

A: ELECTRICAL SPECIFICATION

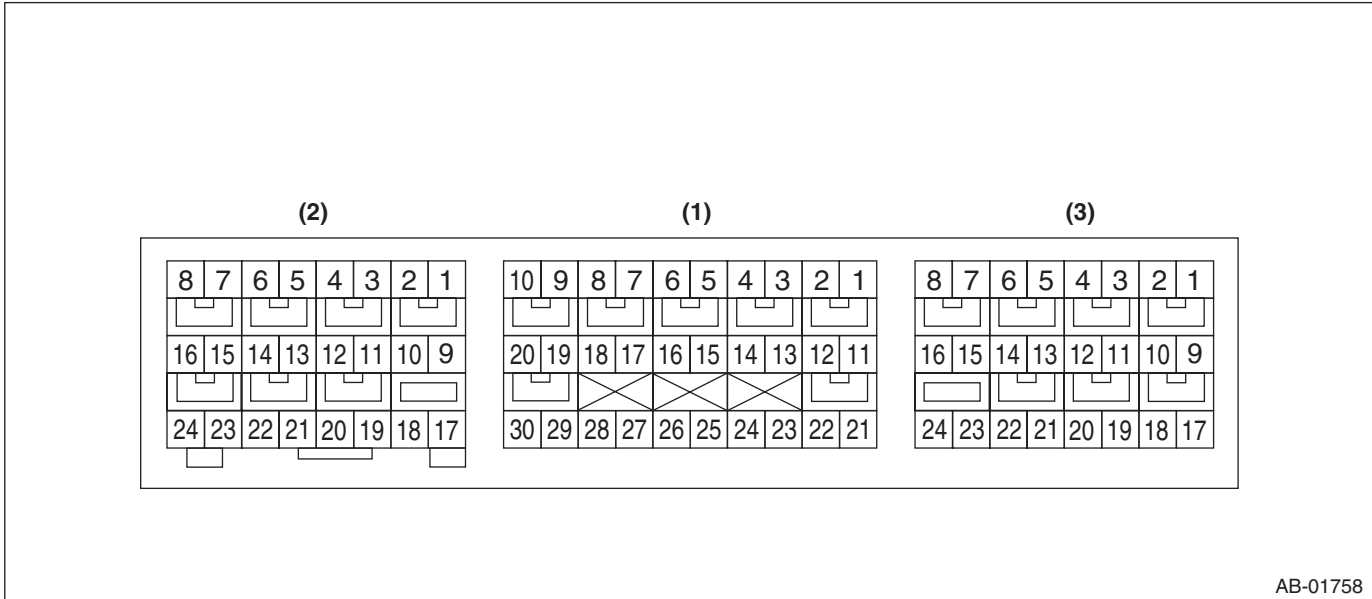

- Terminal numbers in airbag control module connector are shown in the figure.
- Airbag warning light illuminates when the connector is removed from airbag control module.

Airbag Control Module I/O Signal

AIRBAG SYSTEM (DIAGNOSTICS)

Brought to you by Eris Studios
NOT FOR SALE

Item		Control module terminal No.
Data link connector		(1) — 16
Combination meter		(1) — 11
Battery power supply	Dedicated fuse	(1) — 21
Passenger's airbag module level one	+	(1) — 4
	-	(1) — 3
Passenger's airbag module level two	+	(1) — 1
	-	(1) — 2
Driver's airbag module level one	+	(1) — 5
	-	(1) — 6
Driver's airbag module level two	+	(1) — 8
	-	(1) — 7
Front sub sensor LH	+	(1) — 30
	-	(1) — 28
Front sub sensor RH	+	(1) — 29
	-	(1) — 27
Ground line (GND)		(1) — 25
		(1) — 26
Passenger's airbag OFF indicator		(1) — 17
Passenger's airbag ON indicator		(1) — 23
Passenger's seat belt warning light (integrated module)		(1) — 15
Seat belt pretensioner LH	+	(2) — 5
	-	(2) — 6
Side airbag sensor LH Curtain airbag sensor LH	+	(2) — 24
	-	(2) — 23
Side airbag module LH	+	(2) — 1
	-	(2) — 2
Curtain airbag module LH	+	(2) — 4
	-	(2) — 3
Seat belt pretensioner RH	+	(3) — 4
	-	(3) — 3
Side airbag sensor RH Curtain airbag sensor RH	+	(3) — 17
	-	(3) — 18
Side airbag module RH	+	(3) — 8
	-	(3) — 7
Curtain airbag module RH	+	(3) — 5
	-	(3) — 6
Satellite safing sensor	+	(2) — 20
	-	(2) — 21
Occupant detection control module	+	(3) — 16
	-	(3) — 24

B: WIRING DIAGRAM

Refer to the WI section wiring diagram. <Ref. to WI-149, WIRING DIAGRAM, Airbag System.>

7. Subaru Select Monitor

A: OPERATION

1. READ DIAGNOSTIC TROUBLE CODE (DTC)

When malfunction of airbag system occurs, the DTC stored in airbag control module will be read out.

1) Prepare the Subaru Select Monitor kit. <Ref. to AB(diag)-8, SPECIAL TOOL, PREPARATION TOOL, General Description.>

2) Connect the diagnosis cable to the Subaru Select Monitor.

3) Connect the Subaru Select Monitor to the data link connector.

(1) Data link connector is located in the lower portion of instrument panel (on the driver's side).

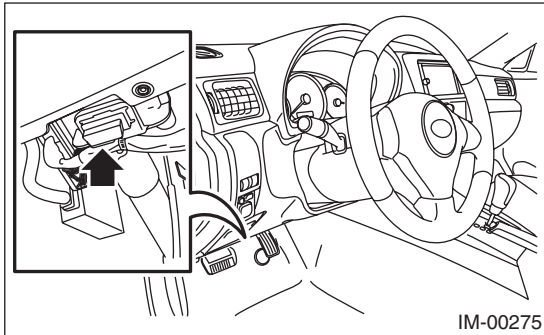

(2) Connect the diagnosis cable to the data link connector.

CAUTION:

Do not connect scan tools other than the Subaru Select Monitor.

4) Turn the ignition switch to ON (engine OFF) and run the Subaru Select Monitor.

5) On the «Main Menu», select {Each System Check}.

6) On the «System Selection Menu», select {Airbag System}.

7) After {Airbag System} is displayed, select [OK].

8) Select the {Diagnostic Trouble Code} in «Airbag System».

NOTE:

- For details concerning the operation procedure, refer to the «help on PC application for Subaru Select Monitor».

- For details concerning DTCs, refer to List of Diagnostic Trouble Codes (DTC). <Ref. to AB(diag)-42, List of Diagnostic Trouble Code (DTC).>

2. DISPLAY OF STATUS INFORMATION

Check the operating condition of each sensor in the event of malfunction in the seat belt buckle switch, or when the seat belt buckle switch has been replaced.

- 1) On the «Main Menu», select {Each System Check}.
- 2) On the «System Selection Menu», select {Airbag System}.
- 3) Select the {Status Data} in «Airbag System».

The following table is for support data.

Item	Display
Seat position sensor LH	— ^{*5}
Seat position sensor RH	— ^{*5}
Seat belt buckle switch LH	— ^{*9}
Seat belt buckle switch RH	Belted ^{*6} /Unbelted ^{*7} /Other ^{*8} /Initial Setting ^{*4} /— ^{*9}
Passenger's airbag control status	ON ^{*10} /OFF ^{*11} /Initial Setting ^{*4}

*1: The seat position is forward.

*2: The seat position is rearward.

*3: Displayed when data other than before and behind the seat, such as the breakdown etc., is input.

*4: Displayed when it is initial.

*5: Seat position sensor not supported

*6: Seat belt fastened

*7: Seat belt not fastened

*8: Displayed when data other than belt fastened or not fastened, such as breakdowns is input.

*9: Seat belt buckle switch not supported

*10: Passenger's airbag operating state

*11: Passenger's airbag non-operating state

NOTE:

For details concerning the operation procedure, refer to the «help on PC application for Subaru Select Monitor».

3. CLEAR MEMORY MODE

Clear the DTC stored in the airbag control module after repairing the airbag system. (After the breakdown is recovered, the breakdown code for completed recoveries are read out when the next breakdown occurs if the memory clear work is not performed.)

- 1) On the «Main Menu», select {Each System Check}.
- 2) On the «System Selection Menu», select {Airbag System}.
- 3) Select the {Clear Memory} in «Airbag System».
- 4) When the “Clear Memory?” is shown on the screen, press [OK].
- 5) When “Done” is displayed, end the Subaru Select Monitor.

NOTE:

For details concerning the operation procedure, refer to the «help on PC application for Subaru Select Monitor».

Subaru Select Monitor

AIRBAG SYSTEM (DIAGNOSTICS)

Brought to you by Eris Studios
NOT FOR RESALE

B: INSPECTION

1. COMMUNICATION FOR INITIALIZING IMPOSSIBLE

DETECTING CONDITION:

Defective harness connector

TROUBLE SYMPTOM:

Communication is impossible between the airbag control module and the Subaru Select Monitor.

WIRING DIAGRAM:

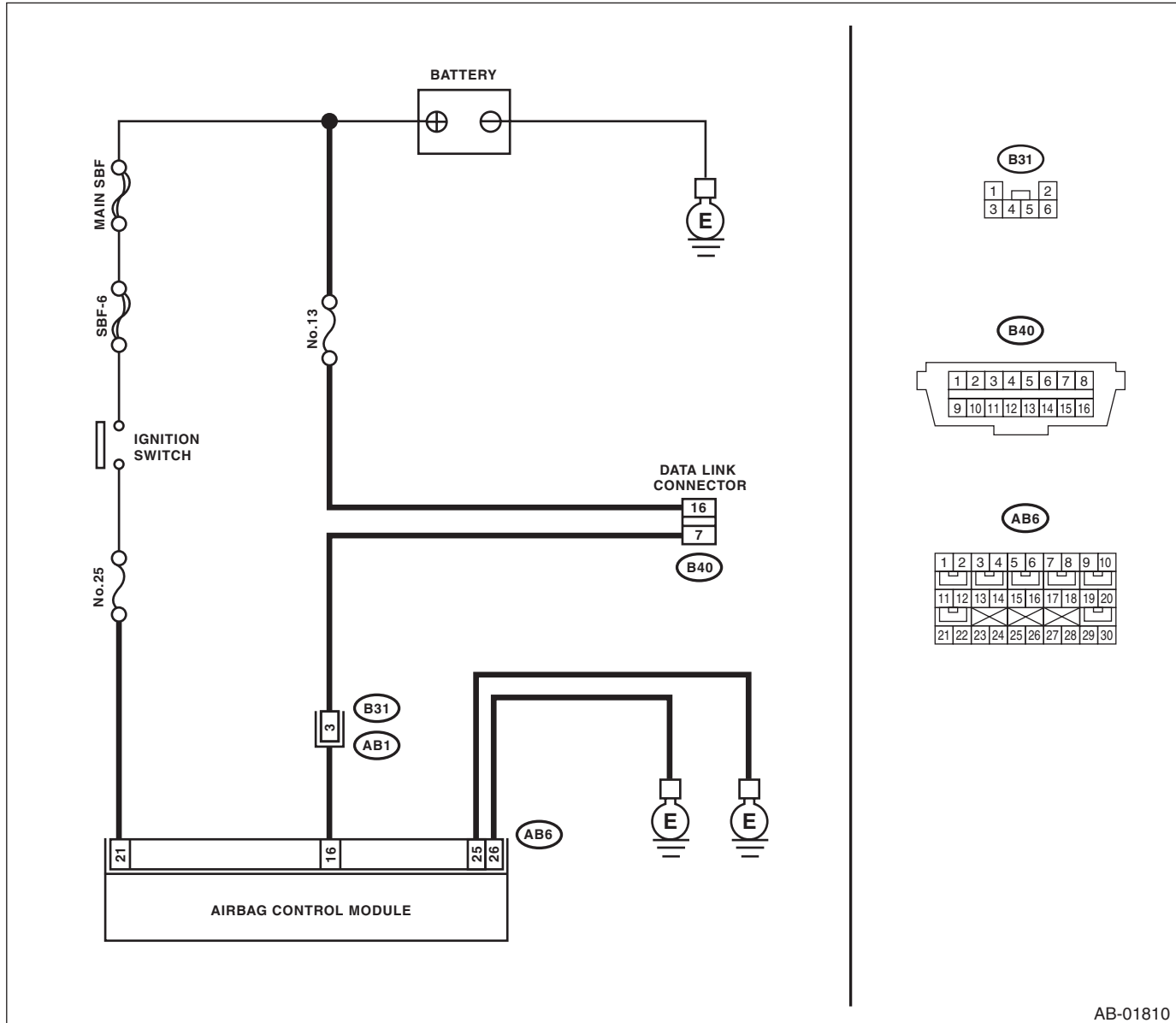

AB-01810

Subaru Select Monitor

AIRBAG SYSTEM (DIAGNOSTICS)

Brought to you by Eris Studios
NOT FOR SALE

	Step	Check	Yes	No
1	CHECK IGNITION SWITCH.	Is the ignition switch ON?	Go to step 2.	Turn the ignition switch to ON, and select the airbag mode using the Subaru Select Monitor.
2	CHECK BATTERY. 1) Turn the ignition switch to OFF. 2) Measure the battery voltage.	Is the voltage 11 V or more?	Go to step 3.	Charge or replace the battery.
3	CHECK BATTERY TERMINAL.	Is there poor contact at battery terminal?	Tighten the battery terminal or replace it.	Go to step 4.
4	CHECK SUBARU SELECT MONITOR COMMUNICATION. 1) Turn the ignition switch to ON. 2) Using the Subaru Select Monitor, check whether communication to other systems can be performed normally.	Is the system name displayed on Subaru Select Monitor?	Go to step 10.	Go to step 5.
5	CHECK FUSE NO. 25 (IN FUSE & RELAY BOX). Remove the fuse No. 25 and perform visual inspection.	Is the fuse No. 25 (in fuse & relay box) blown out?	Replace the fuse No. 25. If fuse No. 25 is blown out again, check the power supply circuit.	Go to step 6.
6	CHECK AIRBAG CONTROL MODULE CONNECTOR. 1) Turn the ignition switch to OFF, disconnect the battery ground cable, and wait 20 seconds or more. 2) Confirm that the connectors of airbag control module (AB6, AB17, and AB18) are securely connected.	Is the connector of the airbag control module securely connected?	Go to step 7.	Connect the connector of the airbag control module.
7	CHECK SUBARU SELECT MONITOR COMMUNICATION. 1) Turn the ignition switch to OFF. 2) Disconnect the airbag control module connector. 3) Turn the ignition switch to ON. 4) Check whether communication to other systems can be executed normally.	Is the system name displayed on Subaru Select Monitor?	Replace the airbag control module. <Ref. to AB-22, Airbag Control Module.>	Go to step 8.
8	CHECK HARNESS CONNECTOR BETWEEN EACH CONTROL MODULE AND DATA LINK CONNECTOR. 1) Turn the ignition switch to OFF. 2) Disconnect the airbag control module, ABSCM&H/U, ECM and TCM. 3) Measure the resistance between data link connector and chassis ground. Connector & terminal (B40) No. 7 — Chassis ground:	Is the resistance 1 MΩ or more?	Go to step 9.	Repair the harness and connector between each control module and data link connector. (Replace the harness without repairing the airbag harness.)
9	CHECK OUTPUT SIGNAL TO THE AIRBAG CONTROL MODULE. 1) Turn the ignition switch to ON in the condition of step 8. 2) Measure the voltage between data link connector and chassis ground. Connector & terminal (B40) No. 7 (+) — Chassis ground (-):	Is the voltage less than 1 V?	Go to step 10.	Repair the harness and connector between each control module and data link connector. (Replace the harness without repairing the airbag harness.)

Subaru Select Monitor

AIRBAG SYSTEM (DIAGNOSTICS)

Brought to you by Eris Studios
NOT FOR RESALE

Step	Check	Yes	No
10 CHECK THE HARNESS BETWEEN THE AIRBAG CONTROL MODULE AND DATA LINK CONNECTOR. 1) Turn the ignition switch to OFF, disconnect the battery ground cable, and wait for 20 seconds or more. 2) Disconnect the connectors (AB6, AB17, and AB18) from airbag control module. 3) Connect the connector (1AG) in the test harness AG to the connectors (AB6, AB17, and AB18). 4) Measure the resistance between connector (4AG) in the test harness AG and the data link connector. Connector & terminal (4AG) No. 1 — (B40) No. 7:	Is the resistance less than 10 Ω?	Go to step 11.	Repair the harness between the airbag control module and the data link connector. Or replace the airbag main harness along with the bulkhead harness.
11 CHECK POWER SUPPLY CIRCUIT. 1) Turn the ignition switch to ON. 2) Measure the voltage between connector (2AG) in the test harness AG and chassis ground. Connector & terminal (2AG) No. 1 — Chassis ground:	Is the voltage 10 V or more?	Go to step 12.	Repair the harness between the airbag control module and the battery. Or replace the airbag main harness along with the bulkhead harness.
12 CHECK BETWEEN THE AIRBAG CONTROL MODULE AND CHASSIS GROUND. 1) Turn the ignition switch to OFF. 2) Measure the resistance between connector (2AG) in the test harness AG and chassis ground. Connector & terminal (2AG) No. 4 — Chassis ground: (2AG) No. 3 — Chassis ground:	Is the resistance less than 10 Ω?	Go to step 13.	Repair the harness between the airbag control module and the chassis ground. Or replace the airbag main harness along with the bulkhead harness.
13 CHECK POOR CONTACT IN CONNECTOR.	Is there poor contact in the control module power supply, ground circuit and data link connector?	Repair the connector. (For airbag system connectors, do not repair but replace the entire harness.)	Replace the airbag control module only. <Ref. to AB-22, REMOVAL, Airbag Control Module.>

2. WITHOUT DTC

DETECTING CONDITION:

- Defective combination meter
- Open circuit in harness

TROUBLE SYMPTOM:

- Airbag warning light remains on.
- “NO TROUBLE CODE” will be displayed on the Subaru Select Monitor.

NOTE:

- For detailed operation procedures, refer to “Airbag Warning Light Failure”. <Ref. to AB(diag)-37, Airbag Warning Light Failure.>
- When the airbag warning light is OFF and “NO TROUBLE CODE” is displayed on Subaru Select Monitor, the system is operating properly.

Read Diagnostic Trouble Code (DTC)

AIRBAG SYSTEM (DIAGNOSTICS)

8. Read Diagnostic Trouble Code (DTC)

A: OPERATION

For details about reading of DTCs, refer to “Subaru Select Monitor”. <Ref. to AB(diag)-28, Subaru Select Monitor.>

Brought to you by Eris Studios
NOT FOR SALE

9. Inspection Mode

A: PROCEDURE

Recreate the circumstance by referring to the conditions described in the checklist.

10. Clear Memory Mode

A: OPERATION

- Clear the memory in the following steps after the malfunction is repaired.
- For details concerning DTC clear operation, refer to “Subaru Select Monitor”. <Ref. to AB(diag)-28, Subaru Select Monitor.>

Airbag Warning Light Illumination Pattern

AIRBAG SYSTEM (DIAGNOSTICS)

Brought to you by Eris Studios
NOT FOR RESALE

11. Airbag Warning Light Illumination Pattern

A: INSPECTION

Turn the ignition switch to ON, and confirm that the airbag warning light remains on for approx. 6 seconds then turns off afterwards.

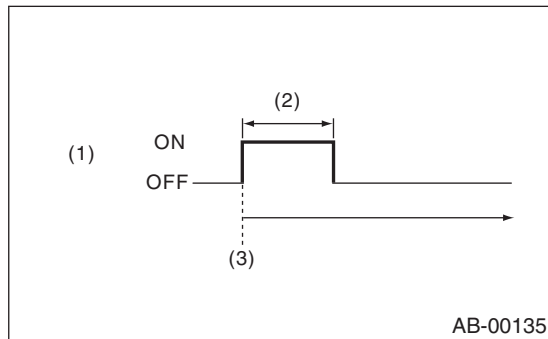

- (1) Airbag warning light
- (2) Approx. 6 sec.
- (3) Ignition switch ON

Brought to you by Eris Studios
NOT FOR SALE

12. Airbag Warning Light Failure

A: AIRBAG WARNING LIGHT REMAINS ON

DETECTING CONDITION:

- Airbag warning light is faulty.
- Airbag control module to airbag warning light circuit is shorted or open.
- Grounding circuit is faulty.
- Airbag control module is faulty.
- Connection of (AB1) and (B31) is improper.
- Connection of (AB6, AB17, and AB18) to airbag control module is improper.

CAUTION:

- Before diagnosing the airbag system, be sure to turn the ignition switch to OFF, disconnect the ground cable from the battery, and wait 20 seconds or more before starting to work.
- When replacing the airbag module, seat belt pretensioner, roll connector, control module and sensor, reconnect each part and check that the warning light operates properly.
- When inspecting the airbag main harness, disconnect the airbag module connectors of the driver's and passenger's seats for safety.
- When inspecting the airbag rear harness, disconnect the side airbag module connector, curtain airbag module connector and seat belt pretensioner connector for safety reasons.

WIRING DIAGRAM:

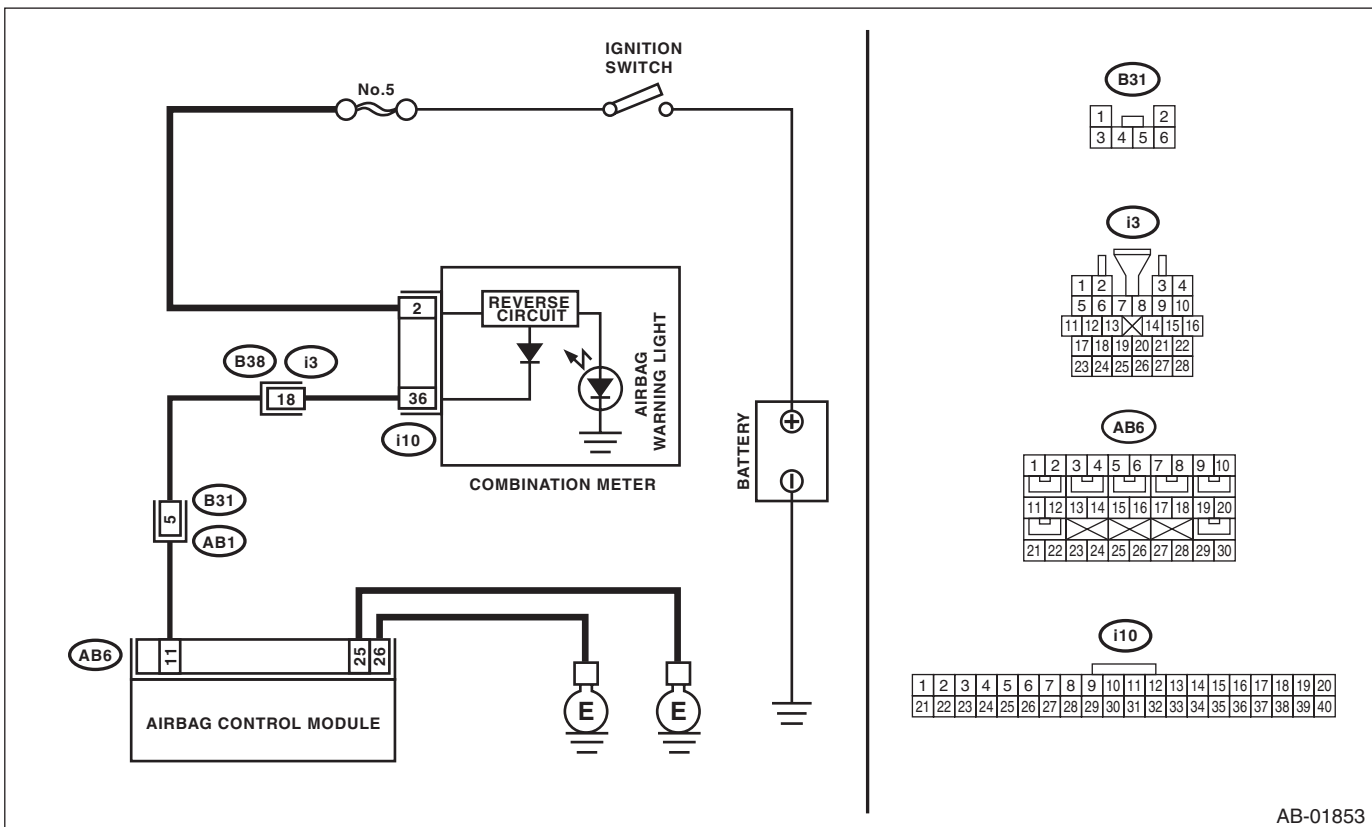

AB-01853

Airbag Warning Light Failure

AIRBAG SYSTEM (DIAGNOSTICS)

Brought to you by Eris Studios
NOT FOR RESALE

	Step	Check	Yes	No
1	READ DTC. Read the DTC. <Ref. to AB(diag)-28, READ DIAGNOSTIC TROUBLE CODE (DTC), OPERATION, Subaru Select Monitor.>	Is DTC displayed?	Perform the diagnosis according to DTC.	Go to step 2.
2	CHECK POOR CONTACT. 1) Turn the ignition switch to OFF, disconnect the battery ground cable, and wait for 20 seconds or more. 2) Confirm that the connectors of airbag control module (AB6, AB17, and AB18) are securely connected.	Is there poor contact in connectors (AB6, AB17, and AB18) ?	If the poor contact of the connector is not fixed, replace the airbag main harness along with body harness or replace the airbag control module. <Ref. to AB-22, Airbag Control Module.>	Go to step 3.
3	CHECK AIRBAG MAIN HARNESS. 1) Remove the instrument panel lower cover and disconnect the connectors (AB7) and (AB2). 2) Remove the instrument panel side cover on the passenger's side and disconnect the connectors (AB10) and (AB9). 3) Disconnect the connectors (AB6, AB17, and AB18) from the airbag control module, and connect the connector (1AG) in the test harness AG. 4) Connect the battery ground terminal and turn the ignition switch to ON. 5) Connect the connectors (7AG) and (8AG) in the test harness AG. NOTE: After the fault has been cleared, disconnect the connectors (7AG) and (8AG).	Does the airbag warning light go off?	Go to step 4.	Go to step 5.
4	CHECK GROUND CIRCUIT. 1) Turn the ignition switch to OFF, disconnect the battery ground cable, and wait for 20 seconds or more. 2) Disconnect the connectors (AB6, AB17, and AB18) from airbag control module. 3) Connect the connector (1AG) in the test harness AG to the body harness connectors (AB6, AB17, and AB18). 4) Measure the resistance between connector (2AG) in the test harness AG and chassis ground. <i>Connector & terminal</i> <i>(2AG) No. 4 — Chassis ground:</i> <i>(2AG) No. 3 — Chassis ground:</i>	Is the resistance less than 10 Ω?	Replace the airbag control module. <Ref. to AB-22, Airbag Control Module.>	Repair the chassis ground circuit.
5	CHECK AIRBAG MAIN HARNESS AND BULKHEAD HARNESS. 1) Disconnect the connectors (7AG) and (8AG). 2) Remove the combination meter. 3) Measure the resistance between the combination meter connector and test harness AG connector (2AG). <i>Connector & terminal</i> <i>(2AG) No. 5 — (i10) No. 36:</i>	Is the resistance less than 10 Ω?	Check the combination meter.	Go to step 6.

Airbag Warning Light Failure

AIRBAG SYSTEM (DIAGNOSTICS)

Brought to you by Eris Studios
NOT FOR SALE

Step	Check	Yes	No
6 CHECK POOR CONTACT OF CONNECTORS (AB1) AND (B31). 1) Turn the ignition switch to OFF, disconnect the battery ground terminal, and wait 20 seconds or more. 2) Confirm that there is a firm contact between connectors (AB1) and (B31).	Is there poor contact in connectors (AB1) and (B31) ?	Repair the bulk-head harness or replace the airbag main harness along with body harness.	Go to step 7.
7 CHECK AIRBAG MAIN HARNESS. Check the airbag main harness for defect.	Is there any defect in the airbag main harness?	Replace the airbag main harness along with bulk-head harness.	Repair the bulk-head harness.

Airbag Warning Light Failure

Brought to you by Eris Studios
NOT FOR RESALE

AIRBAG SYSTEM (DIAGNOSTICS)

B: AIRBAG WARNING LIGHT REMAINS OFF

DETECTING CONDITION:

- Fuse No. 5 (in fuse box) is brown out.
- Body harness circuit is open.
- Airbag warning light is faulty.
- Airbag main harness is faulty.
- Airbag control module is faulty.

CAUTION:

- Before diagnosing the airbag system, be sure to turn the ignition switch to OFF, disconnect the ground terminal from battery, and wait 20 seconds or more before starting to work.
- When replacing the airbag module, seat belt pretensioner, roll connector, control module and sensor, reconnect each part and check that the warning light operates properly.
- When inspecting the airbag main harness, disconnect the airbag module connectors of the driver's and passenger's seats for safety.
- When inspecting the airbag rear harness, disconnect the side airbag module connector, curtain airbag module connector and seat belt pretensioner connector for safety reasons.

WIRING DIAGRAM:

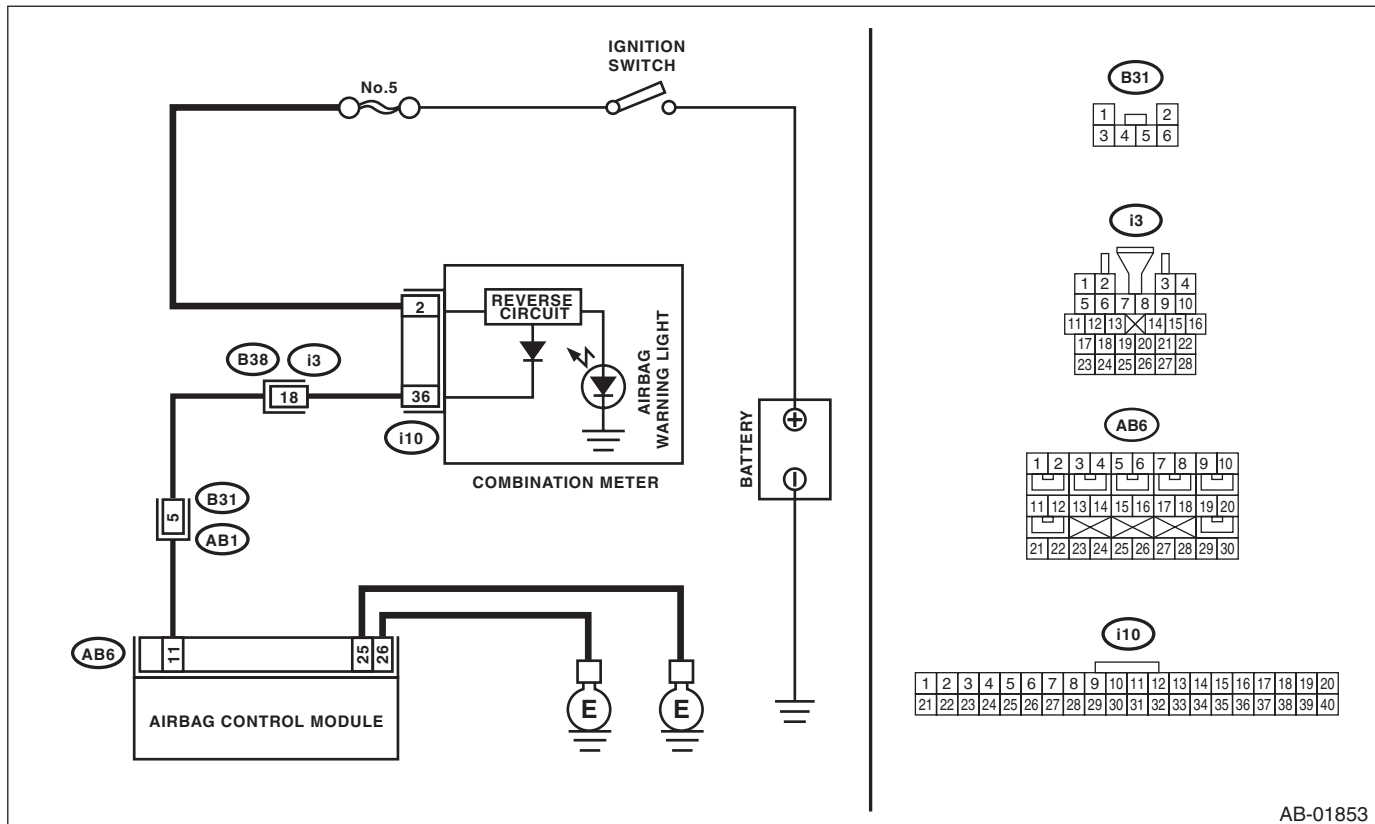

AB-01853

Airbag Warning Light Failure

AIRBAG SYSTEM (DIAGNOSTICS)

Brought to you by Eris Studios
NOT FOR SALE

Step	Check	Yes	No
1 CHECK COMBINATION METER. Turn the ignition switch to ON, and confirm that warning light of combination meter illuminates.	Do warning lights except for airbag illuminate?	Go to step 2.	Check the combination meter.
2 CHECK DTC. Read the DTC. <Ref. to AB(diag)-28, READ DIAGNOSTIC TROUBLE CODE (DTC), OPERATION, Subaru Select Monitor.>	Is DTC displayed?	Perform the diagnosis according to DTC.	Go to step 3.
3 CHECK FUSE NO. 5 (IN MAIN FUSE BOX). Remove the fuse No. 5 and perform visual inspection.	Is the fuse No. 5 (in main fuse box) blown out?	Replace the fuse No. 5. If the fuse No. 5 is blown out again, go to step 4.	Go to step 4.
4 CHECK AIRBAG WARNING LIGHT CIRCUIT (IN COMBINATION METER). 1) Turn the ignition switch to OFF, disconnect the battery ground cable, and wait for 20 seconds or more. 2) Disconnect the connectors (AB1) and (B31). 3) Connect the battery ground terminal and turn the ignition switch to ON.	Does airbag warning light illuminate?	Go to step 5.	Check the combination meter.
5 CHECK AIRBAG MAIN HARNESS. 1) Turn the ignition switch to OFF, disconnect the battery ground cable, and wait for 20 seconds or more. 2) Connect the connector (AB1) and (B31). 3) Disconnect the connectors (AB6, AB17, and AB18) from airbag control module. 4) Connect the battery ground terminal and turn the ignition switch to ON.	Does airbag warning light illuminate?	Replace the airbag control module. <Ref. to AB-22, Airbag Control Module.>	Replace the airbag main harness along with bulkhead harness.

List of Diagnostic Trouble Code (DTC)

AIRBAG SYSTEM (DIAGNOSTICS)

Brought to you by Eris Studios
NOT FOR RESALE

13. List of Diagnostic Trouble Code (DTC)

A: LIST

DTC	Display	Diagnosis content	Reference
11	Driver's Airbag failure	<ul style="list-style-type: none"> • Airbag main harness circuit is open, shorted or shorted to ground. • Airbag module harness (Driver's side) circuit is open, shorted or shorted to ground. • Roll connector circuit is open, shorted or shorted to ground. • Airbag control module is faulty. • Driver's airbag module is faulty. 	<Ref. to AB(diag)-49, DTC 11 DRIVER'S AIRBAG FAILURE, Diagnostic Chart with Trouble Code.>
12	Passenger's Airbag failure	<ul style="list-style-type: none"> • Airbag main harness circuit is open, shorted or shorted to ground. • Airbag module harness (Passenger's side) circuit is open, shorted or shorted to ground. • Airbag control module is faulty. • Passenger's airbag module is faulty. 	<Ref. to AB(diag)-52, DTC 12 PASSENGER'S AIRBAG FAILURE, Diagnostic Chart with Trouble Code.>
15	Driver's Airbag failure	<ul style="list-style-type: none"> • Airbag main harness circuit (Driver's side) is shorted to power supply. • Airbag module harness circuit (Driver's side) is shorted to power supply. • Roll connector is shorted to power supply. • Airbag control module is faulty. • Driver's airbag module is faulty. 	<Ref. to AB(diag)-54, DTC 15 DRIVER'S AIRBAG FAILURE, Diagnostic Chart with Trouble Code.>
16	Passenger's Airbag failure	<ul style="list-style-type: none"> • Airbag main harness circuit (Passenger's side) is shorted to power supply. • Airbag module harness circuit (Passenger's side) is shorted to power supply. • Airbag control module is faulty. • Passenger's airbag module is faulty. 	<Ref. to AB(diag)-57, DTC 16 PASSENGER'S AIRBAG FAILURE, Diagnostic Chart with Trouble Code.>
21	Airbag ECM failure	Airbag control module is faulty.	<Ref. to AB(diag)-58, DTC 21 AIRBAG ECM FAILURE, Diagnostic Chart with Trouble Code.>
22	Front Airbag Firing output	Front airbag module and seat belt pretensioner (LH/RH) are inflated.	<Ref. to AB(diag)-59, DTC 22 FRONT AIRBAG FIRING OUTPUT, Diagnostic Chart with Trouble Code.>
26	Passenger's Airbag indicator failure	<ul style="list-style-type: none"> • Passenger's airbag indicator is faulty. • Airbag control module is faulty. • Airbag main harness circuit is open, shorted or shorted to ground. • Body harness circuit is open. 	<Ref. to AB(diag)-60, DTC 26 PASSENGER'S AIRBAG INDICATOR FAILURE, Diagnostic Chart with Trouble Code.>
27	ODS Communication error	<ul style="list-style-type: none"> • Occupant detection control module communication is faulty. • Airbag rear harness circuit is open, shorted, shorted to ground or shorted to power supply. • Occupant detection harness is faulty. • Airbag control module is faulty. • Occupant detection system is faulty. 	<Ref. to AB(diag)-62, DTC 27 ODS COMMUNICATION ERROR, Diagnostic Chart with Trouble Code.>
29	ODS Failure	<ul style="list-style-type: none"> • Occupant detection sensor is faulty. • Occupant detection control module is faulty. • Occupant detection harness is faulty. • Fuse No. 25 (in joint box) is blown. 	Refer to "Occupant Detection System" for details on DTC 29. <Ref. to OD(diag)-26, DTC 29 ODS FAILURE, Diagnostic Procedure with Diagnostic Trouble Code (DTC).>

List of Diagnostic Trouble Code (DTC)

AIRBAG SYSTEM (DIAGNOSTICS)

Brought to you by Eris Studios
 NOT FOR SALE

DTC	Display	Diagnosis content	Reference
2A	ODS Calibration error	System calibration (Rezeroing) of the occupant detection system was not ended normally.	Refer to "Occupant Detection System" for details on DTC 2A. <Ref. to OD(diag)-23, DTC 2A ODS CALIBRATION ERROR, Diagnostic Procedure with Diagnostic Trouble Code (DTC).>
2B	ODS System wrong parts	<ul style="list-style-type: none"> • Wrong airbag control module was installed. • Wrong occupant detection system was installed. • Occupant detection system is faulty. 	Refer to "Occupant Detection System" for details on DTC 2B. <Ref. to OD(diag)-23, DTC 2B ODS SYSTEM WRONG PARTS, Diagnostic Procedure with Diagnostic Trouble Code (DTC).>
2C	Belt Tension Sensor failure	<ul style="list-style-type: none"> • Passenger's seat belt tension sensor is faulty. • Occupant detection system is faulty. • Airbag rear harness circuit is open, shorted, shorted to ground or shorted to power supply. • Occupant detection harness is faulty. 	Refer to "Occupant Detection System" for details on DTC 2C. <Ref. to OD(diag)-24, DTC 2C BELT TENSION SENSOR FAILURE, Diagnostic Procedure with Diagnostic Trouble Code (DTC).>
33	Front Sub Sensor RH failure	Front sub sensor (RH) is faulty.	<Ref. to AB(diag)-63, DTC 33 FRONT SUB SENSOR RH FAILURE, Diagnostic Chart with Trouble Code.>
34	Front Sub Sensor LH failure	Front sub sensor (LH) is faulty.	<Ref. to AB(diag)-63, DTC 34 FRONT SUB SENSOR LH FAILURE, Diagnostic Chart with Trouble Code.>
37	Buckle Switch RH failure	<ul style="list-style-type: none"> • Passenger's buckle switch circuit is open, shorted or shorted to ground. • Occupant detection system is faulty. • Occupant detection harness is faulty. 	Refer to "Occupant Detection System" for details on DTC 37. <Ref. to OD(diag)-27, DTC 37 BUCKLE SWITCH RH FAILURE, Diagnostic Procedure with Diagnostic Trouble Code (DTC).>
39	Seatbelt Warning failure	<ul style="list-style-type: none"> • Airbag control module is faulty. • Body integrated unit is faulty. • Harness circuits between body integrated unit and airbag control module are open, shorted or shorted to ground. 	<Ref. to AB(diag)-64, DTC 39 SEAT BELT WARNING FAILURE, Diagnostic Chart with Trouble Code.>
41	Side Airbag RH failure	<ul style="list-style-type: none"> • Side airbag harness (RH) circuit is faulty. • Side airbag module (RH) is faulty. • Airbag control module is faulty. 	<Ref. to AB(diag)-66, DTC 41 SIDE AIRBAG RH FAILURE, Diagnostic Chart with Trouble Code.>
42	Side Airbag LH failure	<ul style="list-style-type: none"> • Side airbag harness (LH) circuit is faulty. • Side airbag module (LH) is faulty. • Airbag control module is faulty. 	<Ref. to AB(diag)-68, DTC 42 SIDE AIRBAG LH FAILURE, Diagnostic Chart with Trouble Code.>
45	Side Airbag RH failure	<ul style="list-style-type: none"> • Side airbag harness (RH) is shorted to power supply. • Airbag control module is faulty. 	<Ref. to AB(diag)-70, DTC 45 SIDE AIRBAG RH FAILURE, Diagnostic Chart with Trouble Code.>

List of Diagnostic Trouble Code (DTC)

AIRBAG SYSTEM (DIAGNOSTICS)

Brought to you by Eris Studios
NOT FOR RESALE

DTC	Display	Diagnosis content	Reference
46	Side Airbag LH failure	<ul style="list-style-type: none"> Side airbag harness (LH) is shorted to power supply. Airbag control module is faulty. 	<Ref. to AB(diag)-72, DTC 46 SIDE AIRBAG LH FAILURE, Diagnostic Chart with Trouble Code.>
53	Side Airbag Sensor RH failure	Side airbag sensor (RH) is faulty.	<Ref. to AB(diag)-74, DTC 53 SIDE AIRBAG SENSOR RH FAILURE, Diagnostic Chart with Trouble Code.>
54	Side Airbag Sensor LH failure	Side airbag sensor (LH) is faulty.	<Ref. to AB(diag)-74, DTC 54 SIDE AIRBAG SENSOR LH FAILURE, Diagnostic Chart with Trouble Code.>
55	Side Curtain Airbag Firing output	<ul style="list-style-type: none"> Side airbag module and curtain airbag module are deployed. Curtain airbag module is deployed. 	<Ref. to AB(diag)-74, DTC 55 SIDE CURTAIN AIRBAG FIRING OUTPUT, Diagnostic Chart with Trouble Code.>
58	Curtain Airbag Sensor RH failure	Curtain airbag sensor (RH) is faulty.	<Ref. to AB(diag)-74, DTC 58 CURTAIN AIRBAG SENSOR RH FAILURE, Diagnostic Chart with Trouble Code.>
59	Curtain Airbag Sensor LH failure	Curtain airbag sensor (LH) is faulty.	<Ref. to AB(diag)-74, DTC 59 CURTAIN AIRBAG SENSOR LH FAILURE, Diagnostic Chart with Trouble Code.>
61	Belt Pretensioner RH failure	<ul style="list-style-type: none"> Seat belt pretensioner (RH) circuit is open, shorted or shorted to ground. Airbag control module is faulty. Pretensioner is faulty. Pretensioner harness is faulty. 	<Ref. to AB(diag)-75, DTC 61 BELT PRETENSIONER RH FAILURE, Diagnostic Chart with Trouble Code.>
62	Belt Pretensioner LH failure	<ul style="list-style-type: none"> Seat belt pretensioner (LH) circuit is open, shorted or shorted to ground. Airbag control module is faulty. Pretensioner is faulty. Pretensioner harness is faulty. 	<Ref. to AB(diag)-77, DTC 62 BELT PRETENSIONER LH FAILURE, Diagnostic Chart with Trouble Code.>
65	Belt Pretensioner RH failure	<ul style="list-style-type: none"> Seat belt pretensioner (RH) circuit is shorted to power supply. Pretensioner is faulty. Pretensioner harness is faulty. Airbag control module is faulty. 	<Ref. to AB(diag)-79, DTC 65 BELT PRETENSIONER RH FAILURE, Diagnostic Chart with Trouble Code.>
66	Belt Pretensioner LH failure	<ul style="list-style-type: none"> Seat belt pretensioner (LH) circuit is shorted to power supply. Pretensioner is faulty. Pretensioner harness is faulty. Airbag control module is faulty. 	<Ref. to AB(diag)-81, DTC 66 BELT PRETENSIONER LH FAILURE, Diagnostic Chart with Trouble Code.>
71	Driver's Airbag failure	<ul style="list-style-type: none"> Airbag main harness circuit is open, shorted or shorted to ground. Airbag module harness (Driver's side) circuit is open, shorted or shorted to ground. Roll connector circuit is open, shorted or shorted to ground. Airbag control module is faulty. Driver's airbag module is faulty. 	<Ref. to AB(diag)-83, DTC 71 DRIVER'S AIRBAG FAILURE, Diagnostic Chart with Trouble Code.>

List of Diagnostic Trouble Code (DTC)

AIRBAG SYSTEM (DIAGNOSTICS)

Brought to you by Eris Studios
 NOT FOR SALE

DTC	Display	Diagnosis content	Reference
72	Passenger's Airbag failure	<ul style="list-style-type: none"> • Airbag main harness circuit is open, shorted or shorted to ground. • Airbag module harness (Passenger's side) circuit is open, shorted or shorted to ground. • Airbag control module is faulty. • Passenger's airbag module is faulty. 	<Ref. to AB(diag)-86, DTC 72 PASSENGER'S AIRBAG FAILURE, Diagnostic Chart with Trouble Code.>
75	Driver's Airbag failure	<ul style="list-style-type: none"> • Airbag main harness circuit (Driver's side) is shorted to power supply. • Airbag module harness circuit (Driver's side) is shorted to power supply. • Roll connector is shorted to power supply. • Airbag control module is faulty. • Driver's airbag module is faulty. 	<Ref. to AB(diag)-88, DTC 75 DRIVER'S AIRBAG FAILURE, Diagnostic Chart with Trouble Code.>
76	Passenger's Airbag failure	<ul style="list-style-type: none"> • Airbag main harness circuit (Passenger's side) is shorted to power supply. • Airbag module harness circuit (Passenger's side) is shorted to power supply. • Airbag control module is faulty. • Passenger's airbag module is faulty. 	<Ref. to AB(diag)-91, DTC 76 PASSENGER'S AIRBAG FAILURE, Diagnostic Chart with Trouble Code.>
91	Curtain Airbag Module RH failure	<ul style="list-style-type: none"> • Curtain airbag harness (RH) circuit is faulty. • Curtain airbag module (RH) is faulty. • Airbag control module is faulty. 	<Ref. to AB(diag)-93, DTC 91 CURTAIN AIRBAG MODULE RH FAILURE, Diagnostic Chart with Trouble Code.>
92	Curtain Airbag Module LH failure	<ul style="list-style-type: none"> • Curtain airbag harness (LH) circuit is faulty. • Curtain airbag module (LH) is faulty. • Airbag control module is faulty. 	<Ref. to AB(diag)-95, DTC 92 CURTAIN AIRBAG MODULE LH FAILURE, Diagnostic Chart with Trouble Code.>
95	Curtain Airbag Module RH failure	<ul style="list-style-type: none"> • Curtain airbag harness (RH) is shorted to power supply. • Curtain airbag module (RH) is faulty. • Airbag control module is faulty. 	<Ref. to AB(diag)-97, DTC 95 CURTAIN AIRBAG MODULE RH FAILURE, Diagnostic Chart with Trouble Code.>
96	Curtain Airbag Module LH failure	<ul style="list-style-type: none"> • Curtain airbag harness (LH) is shorted to power supply. • Curtain airbag module (LH) is faulty. • Airbag control module is faulty. 	<Ref. to AB(diag)-99, DTC 96 CURTAIN AIRBAG MODULE LH FAILURE, Diagnostic Chart with Trouble Code.>
E2 E3 E4	Front Sensor Bus RH Communication error	<ul style="list-style-type: none"> • Open or short circuit in harness (RH) between airbag control module and front sub sensor. • Front sub sensor (RH) is faulty. • Airbag control module is faulty. 	<Ref. to AB(diag)-100, DTC E2 FRONT SENSOR BUS RH COMMUNICATION ERROR, Diagnostic Chart with Trouble Code.> <Ref. to AB(diag)-100, DTC E3 FRONT SENSOR BUS RH COMMUNICATION ERROR, Diagnostic Chart with Trouble Code.> <Ref. to AB(diag)-101, DTC E4 FRONT SENSOR BUS RH COMMUNICATION ERROR, Diagnostic Chart with Trouble Code.>

List of Diagnostic Trouble Code (DTC)

AIRBAG SYSTEM (DIAGNOSTICS)

Brought to you by Eris Studios
NOT FOR RESALE

DTC	Display	Diagnosis content	Reference
E6 E7 E8	Front Sensor Bus LH Communication error	<ul style="list-style-type: none"> • Open or short circuit in harness (LH) between airbag control module and front sub sensor. • Front sub sensor (LH) is faulty. • Airbag control module is faulty. 	<p><Ref. to AB(diag)-103, DTC E6 FRONT SENSOR BUS LH COMMUNICATION ERROR, Diagnostic Chart with Trouble Code.></p> <p><Ref. to AB(diag)-103, DTC E7 FRONT SENSOR BUS LH COMMUNICATION ERROR, Diagnostic Chart with Trouble Code.></p> <p><Ref. to AB(diag)-104, DTC E8 FRONT SENSOR BUS LH COMMUNICATION ERROR, Diagnostic Chart with Trouble Code.></p>
E9 EA EB EC	Side Sensor Bus RH Communication error	<ul style="list-style-type: none"> • Open or short circuit in harness (RH) between airbag control module and side sensor. • Side airbag sensor (RH) or curtain airbag sensor (RH) is faulty. • Airbag control module is faulty. 	<p><Ref. to AB(diag)-106, DTC E9 SIDE SENSOR BUS RH COMMUNICATION ERROR, Diagnostic Chart with Trouble Code.></p> <p><Ref. to AB(diag)-106, DTC EA SIDE SENSOR BUS RH COMMUNICATION ERROR, Diagnostic Chart with Trouble Code.></p> <p><Ref. to AB(diag)-106, DTC EB SIDE SENSOR BUS RH COMMUNICATION ERROR, Diagnostic Chart with Trouble Code.></p> <p><Ref. to AB(diag)-107, DTC EC SIDE SENSOR BUS RH COMMUNICATION ERROR, Diagnostic Chart with Trouble Code.></p>
ED EE	Side Sensor Bus RH Communication error	<ul style="list-style-type: none"> • Open or short circuit in harness (RH) between airbag control module and side sensor. • Side airbag sensor (RH) or curtain airbag sensor (RH) is faulty. • Airbag control module is faulty. 	<p><Ref. to AB(diag)-109, DTC ED SIDE SENSOR BUS RH COMMUNICATION ERROR, Diagnostic Chart with Trouble Code.></p> <p><Ref. to AB(diag)-110, DTC EE SIDE SENSOR BUS RH COMMUNICATION ERROR, Diagnostic Chart with Trouble Code.></p>

List of Diagnostic Trouble Code (DTC)

AIRBAG SYSTEM (DIAGNOSTICS)

Brought to you by Eriss Studios
NOT FOR SALE

DTC	Display	Diagnosis content	Reference
F1 F2 F3 F4	Side Sensor Bus LH Communication error	<ul style="list-style-type: none"> • Open or short circuit in harness (LH) between airbag control module and side sensor. • Side airbag sensor (LH) or curtain airbag sensor (LH) is faulty. • Airbag control module is faulty. 	<p><Ref. to AB(diag)-113, DTC F1 SIDE SENSOR BUS LH COMMUNICATION ERROR, Diagnostic Chart with Trouble Code.></p> <p><Ref. to AB(diag)-113, DTC F2 SIDE SENSOR BUS LH COMMUNICATION ERROR, Diagnostic Chart with Trouble Code.></p> <p><Ref. to AB(diag)-113, DTC F3 SIDE SENSOR BUS LH COMMUNICATION ERROR, Diagnostic Chart with Trouble Code.></p> <p><Ref. to AB(diag)-114, DTC F4 SIDE SENSOR BUS LH COMMUNICATION ERROR, Diagnostic Chart with Trouble Code.></p>
F5 F6	Side Sensor Bus LH Communication error	<ul style="list-style-type: none"> • Open or short circuit in harness (LH) between airbag control module and side sensor. • Side airbag sensor (LH) or curtain airbag sensor (LH) is faulty. • Airbag control module is faulty. 	<p><Ref. to AB(diag)-116, DTC F5 SIDE SENSOR BUS LH COMMUNICATION ERROR, Diagnostic Chart with Trouble Code.></p> <p><Ref. to AB(diag)-117, DTC F6 SIDE SENSOR BUS LH COMMUNICATION ERROR, Diagnostic Chart with Trouble Code.></p>
F8 F9 FA	Satellite Sensor Bus Communication error	<ul style="list-style-type: none"> • Open or short circuit in harness between airbag control module and satellite safing sensor. • Satellite safing sensor is faulty. • Airbag control module is faulty. 	<p><Ref. to AB(diag)-120, DTC F8 SATELLITE SENSOR BUS COMMUNICATION ERROR, Diagnostic Chart with Trouble Code.></p> <p><Ref. to AB(diag)-120, DTC F9 SATELLITE SENSOR BUS COMMUNICATION ERROR, Diagnostic Chart with Trouble Code.></p> <p><Ref. to AB(diag)-121, DTC FA SATELLITE SENSOR BUS COMMUNICATION ERROR, Diagnostic Chart with Trouble Code.></p>
3A	Front Sub Sensor RH False installation	<ul style="list-style-type: none"> • Front sensor (RH) is misinstalled. • Airbag control module is faulty. 	<p><Ref. to AB(diag)-123, DTC 3A FRONT SUB SENSOR RH FALSE INSTALLATION, Diagnostic Chart with Trouble Code.></p>
3B	Front Sub Sensor LH False installation	<ul style="list-style-type: none"> • Front sensor (LH) is misinstalled. • Airbag control module is faulty. 	<p><Ref. to AB(diag)-123, DTC 3B FRONT SUB SENSOR LH FALSE INSTALLATION, Diagnostic Chart with Trouble Code.></p>

List of Diagnostic Trouble Code (DTC)

AIRBAG SYSTEM (DIAGNOSTICS)

Brought to you by Eris Studios
NOT FOR RESALE

DTC	Display	Diagnosis content	Reference
3C	Satellite Sensor Bus failure	Satellite safing sensor is faulty.	<Ref. to AB(diag)-123, DTC 3C SATELLITE SENSOR BUS FAILURE, Diagnostic Chart with Trouble Code.>
3D	Satellite Sensor False installation	<ul style="list-style-type: none"> • Satellite safing sensor is misinstalled. • Airbag control module is faulty. 	<Ref. to AB(diag)-123, DTC 3D SATELLITE SENSOR FALSE INSTALLATION, Diagnostic Chart with Trouble Code.>
5A	Side Airbag Sensor RH False installation	<ul style="list-style-type: none"> • Side A/B sensor is misinstalled. • Airbag control module is faulty. 	<Ref. to AB(diag)-124, DTC 5A SIDE AIRBAG SENSOR RH FALSE INSTALLATION, Diagnostic Chart with Trouble Code.>
5B	Side Airbag Sensor LH False installation	<ul style="list-style-type: none"> • Side A/B sensor is misinstalled. • Airbag control module is faulty. 	<Ref. to AB(diag)-124, DTC 5B SIDE AIRBAG SENSOR LH FALSE INSTALLATION, Diagnostic Chart with Trouble Code.>
5C	Curtain Airbag Sensor RH False installation	<ul style="list-style-type: none"> • Curtain A/B sensor is misinstalled. • Airbag control module is faulty. 	<Ref. to AB(diag)-124, DTC 5C CURTAIN AIRBAG SENSOR RH FALSE INSTALLATION, Diagnostic Chart with Trouble Code.>
5D	Curtain Airbag Sensor LH False installation	<ul style="list-style-type: none"> • Curtain A/B sensor is misinstalled. • Airbag control module is faulty. 	<Ref. to AB(diag)-124, DTC 5D CURTAIN AIRBAG SENSOR LH FALSE INSTALLATION, Diagnostic Chart with Trouble Code.>

14. Diagnostic Chart with Trouble Code

A: DTC 11 DRIVER'S AIRBAG FAILURE

DTC DETECTING CONDITION:

- Airbag main harness circuit is open, shorted or shorted to ground.
- Airbag module harness (driver's side) circuit is open, shorted or shorted to ground.
- Roll connector circuit is open, shorted or shorted to ground.
- Driver's airbag module is faulty.
- Airbag control module is faulty.

CAUTION:

- Before diagnosing the airbag system, be sure to turn the ignition switch to OFF, disconnect the ground cable from the battery, and wait 20 seconds or more before starting to work.
- When replacing the airbag module, seat belt pretensioner, roll connector, control module and sensor, reconnect each part and check that the warning light operates properly.
- When inspecting the airbag main harness, disconnect the airbag module connectors of the driver's and passenger's seats for safety.
- When inspecting the airbag rear harness, disconnect the side airbag module connector, curtain airbag module connector and seat belt pretensioner connector for safety reasons.

NOTE:

Prior to starting work, prepare two airbag resistors (98299PA040).

WIRING DIAGRAM:

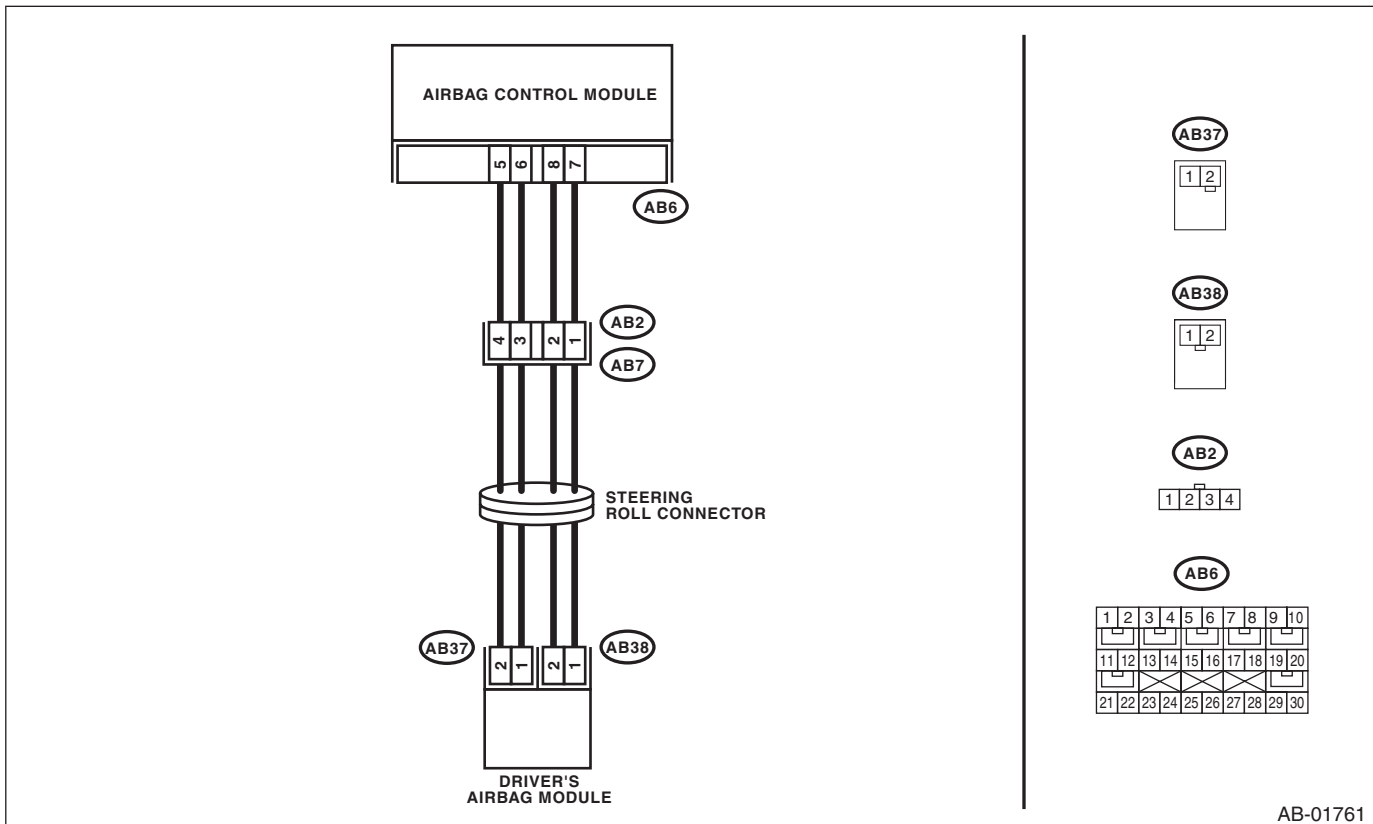

Diagnostic Chart with Trouble Code

AIRBAG SYSTEM (DIAGNOSTICS)

Brought to you by Eris Studios
NOT FOR RESALE

Step	Check	Yes	No
1 CHECK POOR CONTACT IN CONNECTORS. Check for poor contact of the connectors between the airbag control module and the driver's airbag module.	Is there poor contact?	Replace the airbag harness.	Go to step 2.
2 CHECK DRIVER'S AIRBAG MODULE. 1) Turn the ignition switch to OFF, disconnect the battery ground cable, and wait for 20 seconds or more. 2) Remove the driver's airbag module. 3) Connect the connector (1N) in the test harness N to the connector (AB38). 4) Connect the airbag resistor to the connector (2N) of test harness N. 5) Connect the connector (1Q) in the test harness Q to connector (AB37). 6) Connect the airbag resistor to the connector (2Q) in the test harness Q. 7) Connect the battery ground terminal and turn the ignition switch to ON.	Does the airbag warning light illuminate for 6 seconds and go off?	Replace the driver's airbag module. <Ref. to AB-16, Driver's Airbag Module.>	Go to step 3.
3 CHECK ROLL CONNECTOR. 1) Turn the ignition switch to OFF, disconnect the battery ground cable, and wait for 20 seconds or more. 2) Disconnect the test harness N from connector (AB38). 3) Disconnect the test harness Q from connector (AB37). 4) Remove the instrument panel lower cover and disconnect the connector (AB7) from (AB2). 5) Connect the connector (1P) in the test harness P to connector (AB2). 6) Connect the airbag resistor to the connectors (2P) and (3P) of test harness P. 7) Connect the battery ground terminal and turn the ignition switch to ON.	Does the airbag warning light illuminate for 6 seconds and go off?	Replace the roll connector. <Ref. to AB-27, Roll Connector.>	Go to step 4.
4 CHECK AIRBAG MAIN HARNESS (DRIVER'S AIRBAG HARNESS). 1) Turn the ignition switch to OFF, disconnect the battery ground cable, and wait for 20 seconds or more. 2) Disconnect the airbag resistor from the connectors (2P) and (3P) of test harness P. 3) Remove the instrument panel side cover on the passenger's side and disconnect the connectors (AB10) and (AB9). 4) Disconnect the connectors (AB6, AB17, and AB18) from the airbag control module, and connect the connector (1AG) in the test harness AG. 5) Measure the resistance between connector (3AG) in the test harness AG and connectors (2P) and (3P) in the test harness P. Connector & terminal (3AG) No. 1 — (2P) No. 1: (3AG) No. 3 — (2P) No. 2:	Is the resistance less than 10 Ω?	Go to step 5.	Replace the airbag main harness along with body harness.

Diagnostic Chart with Trouble Code

AIRBAG SYSTEM (DIAGNOSTICS)

Brought to you by Eris Studios
NOT FOR SALE

Step	Check	Yes	No
<p>5 CHECK AIRBAG MAIN HARNESS (DRIVER'S AIRBAG HARNESS). Measure the resistance between connector (3AG) terminals in the test harness AG. Connector & terminal <i>(3AG) No. 1 — (3AG) No. 3:</i> <i>(3AG) No. 3 — Chassis ground:</i> <i>(3AG) No. 1 — Chassis ground:</i> <i>(3AG) No. 2 — (3AG) No. 4:</i> <i>(3AG) No. 2 — Chassis ground:</i> <i>(3AG) No. 4 — Chassis ground:</i> <i>(3AG) No. 1 — (3AG) No. 2:</i> <i>(3AG) No. 1 — (3AG) No. 4:</i> <i>(3AG) No. 2 — (3AG) No. 3:</i> <i>(3AG) No. 3 — (3AG) No. 4:</i></p>	Is the resistance 1 MΩ or more?	Go to step 6.	Replace the airbag main harness along with body harness.
<p>6 CHECK AIRBAG CONTROL MODULE. 1) Connect all connectors. 2) Erase the memory. 3) Perform the Inspection Mode. 4) Read the DTC.</p>	Is the same DTC displayed?	Replace the airbag control module. <Ref. to AB-22, Airbag Control Module.>	Go to step 7.
<p>7 CHECK FOR ANY OTHER DTC ON DISPLAY.</p>	Is any other DTC displayed?	Check DTC using "List of Diagnostic Trouble Code (DTC)". <Ref. to AB(diag)-42, List of Diagnostic Trouble Code (DTC).>	Finish the diagnosis.

Diagnostic Chart with Trouble Code

Brought to you by Eris Studios
NOT FOR RESALE

AIRBAG SYSTEM (DIAGNOSTICS)

B: DTC 12 PASSENGER'S AIRBAG FAILURE

DTC DETECTING CONDITION:

- Airbag main harness circuit is open, shorted or shorted to ground.
- Airbag module harness (Passenger's side) circuit is open, shorted or shorted to ground.
- Passenger's airbag module is faulty.
- Airbag control module is faulty.

CAUTION:

- Before diagnosing the airbag system, be sure to turn the ignition switch to OFF, disconnect the ground cable from the battery, and wait 20 seconds or more before starting to work.
- When replacing the airbag module, seat belt pretensioner, roll connector, control module and sensor, reconnect each part and check that the warning light operates properly.
- When inspecting the airbag main harness, disconnect the airbag module connectors of the driver's and passenger's seats for safety.
- When inspecting the airbag rear harness, disconnect the side airbag module connector, curtain airbag module connector and seat belt pretensioner connector for safety reasons.

NOTE:

Prior to starting work, prepare two airbag resistors (98299PA040).

WIRING DIAGRAM:

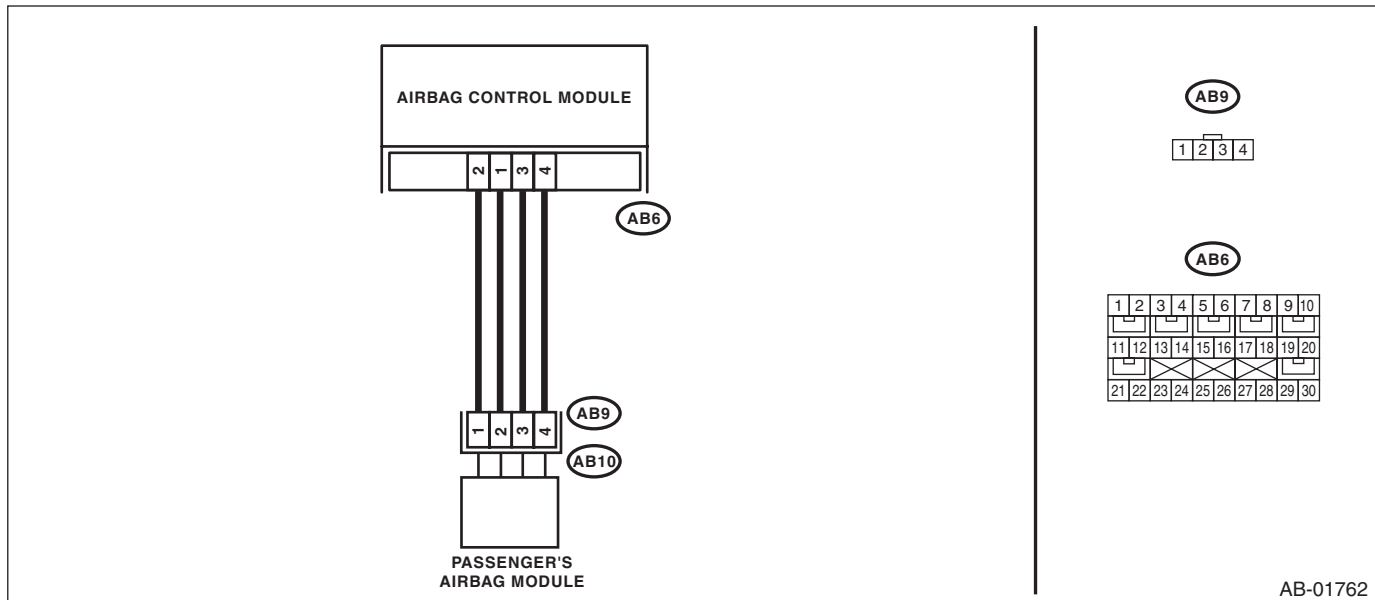

Step	Check	Yes	No
1 CHECK POOR CONTACT IN CONNECTORS. Check for poor contact of the connectors between the airbag control module and the passenger's airbag module.	Is there poor contact?	Replace the airbag harness.	Go to step 2.
2 CHECK PASSENGER'S AIRBAG MODULE. 1) Turn the ignition switch to OFF, disconnect the battery ground cable, and wait for 20 seconds or more. 2) Remove the instrument panel side cover on the passenger's side and disconnect the connector (AB10) from (AB9). 3) Connect the connector (1P) in the test harness P to connector (AB9). 4) Connect the airbag resistor to the connectors (2P) and (3P) of test harness P. 5) Connect the battery ground terminal and turn the ignition switch to ON.	Does the airbag warning light illuminate for 6 seconds and go off?	Replace the passenger's airbag module. <Ref. to AB-17, Passenger's Airbag Module.>	Go to step 3.

Diagnostic Chart with Trouble Code

AIRBAG SYSTEM (DIAGNOSTICS)

Brought to you by Eris Studios
NOT FOR SALE

Step	Check	Yes	No
3 CHECK AIRBAG MAIN HARNESS (PASSENGER'S AIRBAG HARNESS). 1) Turn the ignition switch to OFF, disconnect the battery ground cable, and wait for 20 seconds or more. 2) Disconnect the airbag resistor from the connectors (2P) and (3P) of test harness P. 3) Remove the instrument panel lower cover and disconnect the connector (AB7) from (AB2). 4) Disconnect the connectors (AB6, AB17, and AB18) from the airbag control module, and connect the connector (1AG) in the test harness AG. 5) Measure the resistance between connector (3AG) in the test harness AG and connectors (2P) and (3P) in the test harness P. Connector & terminal <i>(3AG) No. 9 — (2P) No. 1:</i> <i>(3AG) No. 7 — (2P) No. 2:</i>	Is the resistance less than 10 Ω?	Go to step 4.	Replace the airbag main harness along with body harness.
4 CHECK AIRBAG MAIN HARNESS (PASSENGER'S AIRBAG HARNESS). Measure the resistance between connectors (3AG) in the test harness AG, and between connector (3AG) and chassis ground. Connector & terminal <i>(3AG) No. 9 — (3AG) No. 7:</i> <i>(3AG) No. 9 — Chassis ground:</i> <i>(3AG) No. 7 — Chassis ground:</i> <i>(3AG) No. 8 — (3AG) No. 6:</i> <i>(3AG) No. 8 — Chassis ground:</i> <i>(3AG) No. 6 — Chassis ground:</i> <i>(3AG) No. 7 — (3AG) No. 6:</i> <i>(3AG) No. 6 — (3AG) No. 9:</i> <i>(3AG) No. 7 — (3AG) No. 8:</i> <i>(3AG) No. 8 — (3AG) No. 9:</i>	Is the resistance 1 MΩ or more?	Go to step 5.	Replace the airbag main harness along with body harness.
5 CHECK AIRBAG CONTROL MODULE. 1) Connect all connectors. 2) Erase the memory. 3) Perform the Inspection Mode. 4) Read the DTC.	Is the same DTC displayed?	Replace the airbag control module. <Ref. to AB-22, Airbag Control Module.>	Go to step 6.
6 CHECK FOR ANY OTHER DTC ON DISPLAY.	Is any other DTC displayed?	Check DTC using "List of Diagnostic Trouble Code (DTC)". <Ref. to AB(diag)-42, List of Diagnostic Trouble Code (DTC).>	Finish the diagnosis.

Diagnostic Chart with Trouble Code

Brought to you by Eris Studios
NOT FOR RESALE

AIRBAG SYSTEM (DIAGNOSTICS)

C: DTC 15 DRIVER'S AIRBAG FAILURE

DTC DETECTING CONDITION:

- Airbag main harness circuit (Driver's side) is shorted to power supply.
- Airbag module harness circuit (Driver's side) is shorted to power supply.
- Roll connector is shorted to power supply.
- Driver's airbag module is faulty.
- Airbag control module is faulty.

CAUTION:

- Before diagnosing the airbag system, be sure to turn the ignition switch to OFF, disconnect the ground cable from the battery, and wait 20 seconds or more before starting to work.
- When replacing the airbag module, seat belt pretensioner, roll connector, control module and sensor, reconnect each part and check that the warning light operates properly.
- When inspecting the airbag main harness, disconnect the airbag module connectors of the driver's and passenger's seats for safety.
- When inspecting the airbag rear harness, disconnect the side airbag module connector, curtain airbag module connector and seat belt pretensioner connector for safety reasons.

NOTE:

Prior to starting work, prepare two airbag resistors (98299PA040).

WIRING DIAGRAM:

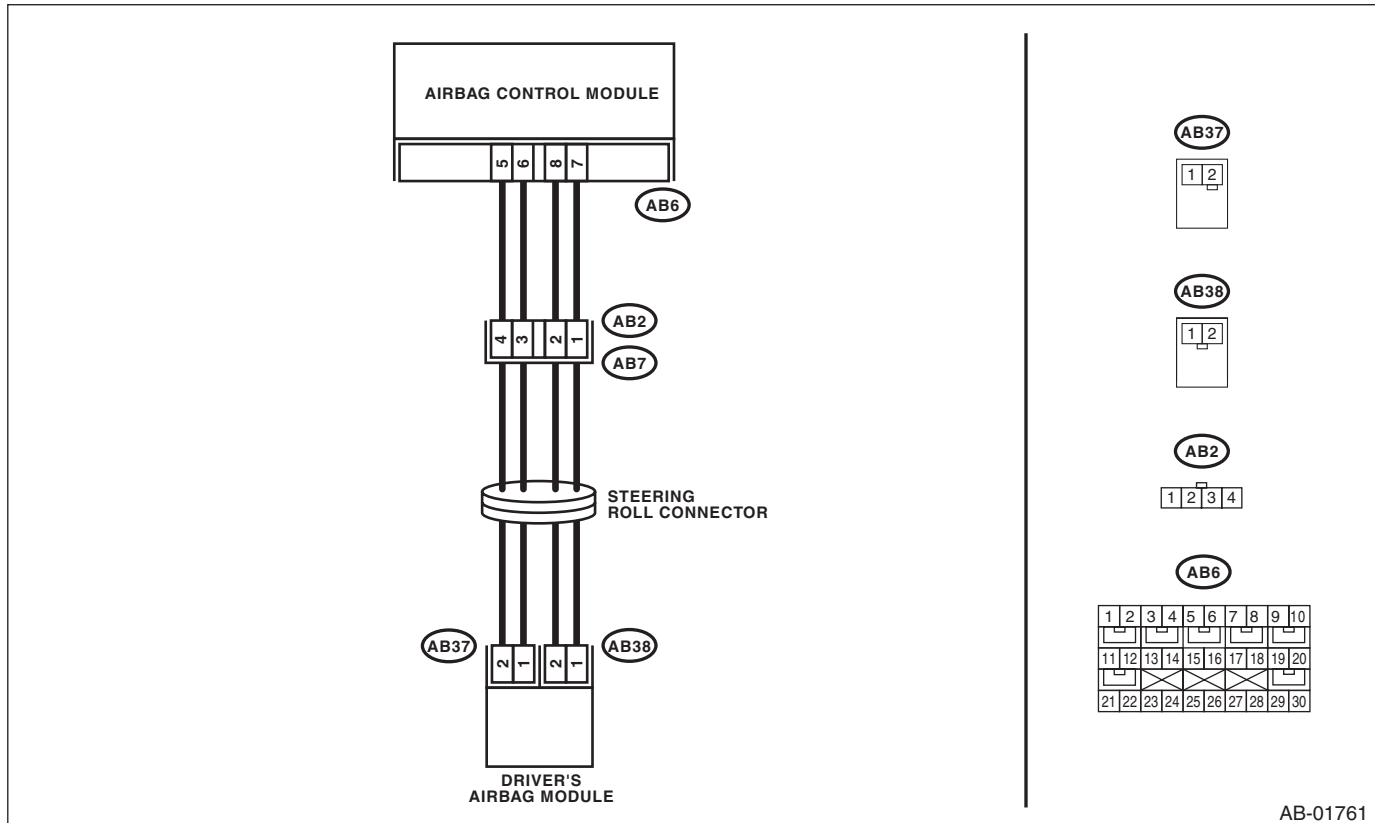

AB-01761

Diagnostic Chart with Trouble Code

AIRBAG SYSTEM (DIAGNOSTICS)

Brought to you by Eris Studios
NOT FOR RESALE

Step	Check	Yes	No
1 CHECK POOR CONTACT IN CONNECTORS. Check for poor contact of the connectors between the airbag control module and the driver's airbag module.	Is there poor contact?	Replace the airbag harness.	Go to step 2.
2 CHECK DRIVER'S AIRBAG MODULE. 1) Turn the ignition switch to OFF, disconnect the battery ground cable, and wait for 20 seconds or more. 2) Remove the driver's airbag module. 3) Connect the connector (AB38) to the connector (1N) in the test harness N. 4) Connect the airbag resistor to the connector (2N) of test harness N. 5) Connect the connector (1Q) in the test harness Q to connector (AB37). 6) Connect the airbag resistor to the connector (2Q) in the test harness Q. 7) Connect the battery ground terminal and turn the ignition switch to ON.	Does the airbag warning light illuminate for 6 seconds and go off?	Replace the driver's airbag module. <Ref. to AB-16, Driver's Airbag Module.>	Go to step 3.
3 CHECK ROLL CONNECTOR. 1) Turn the ignition switch to OFF, disconnect the battery ground cable, and wait for 20 seconds or more. 2) Disconnect the test harness N from connector (AB38). 3) Disconnect the test harness Q from connector (AB37). 4) Remove the instrument panel lower cover and disconnect the connector (AB7) from (AB2). 5) Connect the connector (1P) in the test harness P to connector (AB2). 6) Connect the airbag resistor to the connectors (2P) and (3P) of test harness P. 7) Connect the battery ground terminal and turn the ignition switch to ON.	Does the airbag warning light illuminate for 6 seconds and go off?	Replace the roll connector. <Ref. to AB-27, Roll Connector.>	Go to step 4.
4 CHECK AIRBAG MAIN HARNESS (DRIVER'S AIRBAG HARNESS). 1) Turn the ignition switch to OFF, disconnect the battery ground cable, and wait for 20 seconds or more. 2) Disconnect the airbag resistor from the connectors (2P) and (3P) of test harness P. 3) Remove the instrument panel side cover on the passenger's side and disconnect the connectors (AB10) and (AB9). 4) Disconnect the connectors (AB6, AB17, and AB18) from the airbag control module, and connect the connector (1AG) in the test harness AG. 5) Connect the battery ground terminal and turn the ignition switch to ON. (engine OFF) 6) Measure the voltage between connector (3AG) in the test harness AG and chassis ground. Connector & terminal (3AG) No. 3 (+) — Chassis ground (-): (3AG) No. 1 (+) — Chassis ground (-):	Is the voltage less than 1 V?	Go to step 5.	Replace the airbag main harness along with body harness.

Diagnostic Chart with Trouble Code

AIRBAG SYSTEM (DIAGNOSTICS)

Brought to you by Eris Studios
NOT FOR RESALE

Step	Check	Yes	No
5 CHECK AIRBAG CONTROL MODULE. 1) Connect all connectors. 2) Erase the memory. 3) Perform the Inspection Mode. 4) Read the DTC.	Is the same DTC displayed?	Replace the airbag control module. <Ref. to AB-22, Airbag Control Module.>	Go to step 6 .
6 CHECK FOR ANY OTHER DTC ON DISPLAY.	Is any other DTC displayed?	Check DTC using "List of Diagnostic Trouble Code (DTC)". <Ref. to AB(diag)-42, List of Diagnostic Trouble Code (DTC).>	Finish the diagnosis.

Diagnostic Chart with Trouble Code

AIRBAG SYSTEM (DIAGNOSTICS)

Brought to you by Eris Studios
NOT FOR SALE

D: DTC 16 PASSENGER'S AIRBAG FAILURE

DTC DETECTING CONDITION:

- Airbag main harness circuit (Passenger's side) is shorted to power supply.
- Airbag module harness circuit (Passenger's side) is shorted to power supply.
- Passenger's airbag module is faulty.
- Airbag control module is faulty.

CAUTION:

- Before diagnosing the airbag system, be sure to turn the ignition switch to OFF, disconnect the ground cable from the battery, and wait 20 seconds or more before starting to work.
- When replacing the airbag module, seat belt pretensioner, roll connector, control module and sensor, reconnect each part and check that the warning light operates properly.
- When inspecting the airbag main harness, disconnect the airbag module connectors of the driver's and passenger's seats for safety.
- When inspecting the airbag rear harness, disconnect the side airbag module connector, curtain airbag module connector and seat belt pretensioner connector for safety reasons.

NOTE:

Prior to starting work, prepare two airbag resistors (98299PA040).

WIRING DIAGRAM:

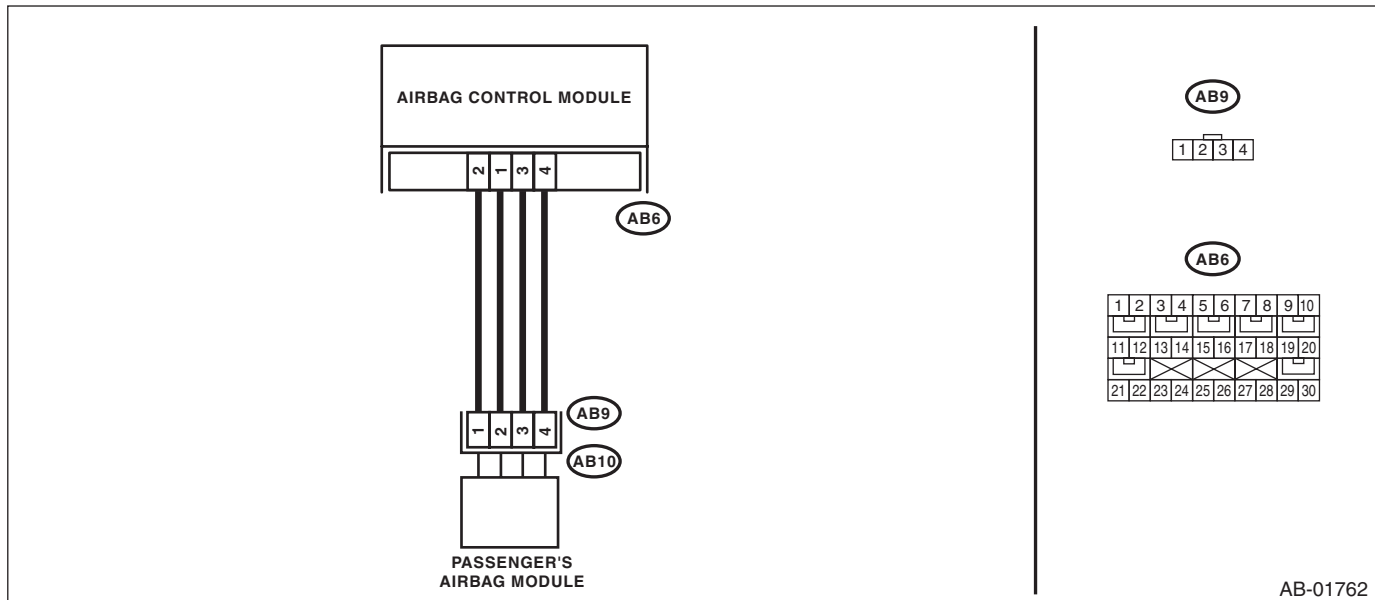

Step	Check	Yes	No
1 CHECK POOR CONTACT IN CONNECTORS. Check for poor contact of the connectors between the airbag control module and the passenger's airbag module.	Is there poor contact?	Replace the airbag harness along with chassis harness.	Go to step 2.
2 CHECK PASSENGER'S AIRBAG MODULE. 1) Turn the ignition switch to OFF, disconnect the battery ground cable, and wait for 20 seconds or more. 2) Remove the instrument panel side cover on the passenger's side and disconnect the connector (AB10) from (AB9). 3) Connect the connector (1P) in the test harness P to connector (AB9). 4) Connect the airbag resistor to the connectors (2P) and (3P) of test harness P. 5) Connect the battery ground terminal and turn the ignition switch to ON.	Does the airbag warning light illuminate for 6 seconds and go off?	Replace the passenger's airbag module. <Ref. to AB-17, Passenger's Airbag Module.>	Go to step 3.

Diagnostic Chart with Trouble Code

AIRBAG SYSTEM (DIAGNOSTICS)

Brought to you by Eris Studios
NOT FOR RESALE

Step	Check	Yes	No
3 CHECK AIRBAG MAIN HARNESS (PASSENGER'S AIRBAG HARNESS). 1) Turn the ignition switch to OFF, disconnect the battery ground cable, and wait for 20 seconds or more. 2) Disconnect the airbag resistor from the connectors (2P) and (3P) of test harness P. 3) Remove the instrument panel lower cover and disconnect the connector (AB7) from (AB2). 4) Disconnect the connectors (AB6, AB17, and AB18) from the airbag control module, and connect the connector (1AG) in the test harness AG. 5) Connect the battery ground terminal and turn the ignition switch to ON. (engine OFF) 6) Measure the voltage between connector (3AG) in the test harness AG and chassis ground. Connector & terminal (3AG) No. 9 (+) — Chassis ground (-): (3AG) No. 7 (+) — Chassis ground (-):	Is the voltage less than 1 V?	Go to step 4.	Replace the airbag main harness along with body harness.
4 CHECK AIRBAG CONTROL MODULE. 1) Connect all connectors. 2) Erase the memory. 3) Perform the Inspection Mode. 4) Read the DTC.	Is the same DTC displayed?	Replace the airbag control module. <Ref. to AB-22, Airbag Control Module.>	Go to step 5.
5 CHECK FOR ANY OTHER DTC ON DISPLAY.	Is any other DTC displayed?	Check DTC using "List of Diagnostic Trouble Code (DTC)". <Ref. to AB(diag)-42, List of Diagnostic Trouble Code (DTC).>	Finish the diagnosis.

E: DTC 21 AIRBAG ECM FAILURE

DTC DETECTING CONDITION:

Airbag control module is faulty.

CAUTION:

- Before diagnosing the airbag system, be sure to turn the ignition switch to OFF, disconnect the ground terminal from battery, and wait 20 seconds or more before starting to work.
- When replacing the airbag module, seat belt pretensioner, roll connector, control module and sensor, reconnect each part and check that the warning light operates properly.

Step	Check	Yes	No
1 CHECK IF DTC 21 IS INDICATED. Read the DTC. <Ref. to AB(diag)-28, READ DIAGNOSTIC TROUBLE CODE (DTC), OPERATION, Subaru Select Monitor.>	Does the Subaru Select Monitor display DTC21?	Replace the airbag control module. <Ref. to AB-22, Airbag Control Module.>	Perform the Clear Memory Mode. <Ref. to AB(diag)-29, CLEAR MEMORY MODE, OPERATION, Subaru Select Monitor.>

Diagnostic Chart with Trouble Code

AIRBAG SYSTEM (DIAGNOSTICS)

Brought to you by Eris Studios
NOT FOR SALE

F: DTC 22 FRONT AIRBAG FIRING OUTPUT

WIRING DIAGRAM:

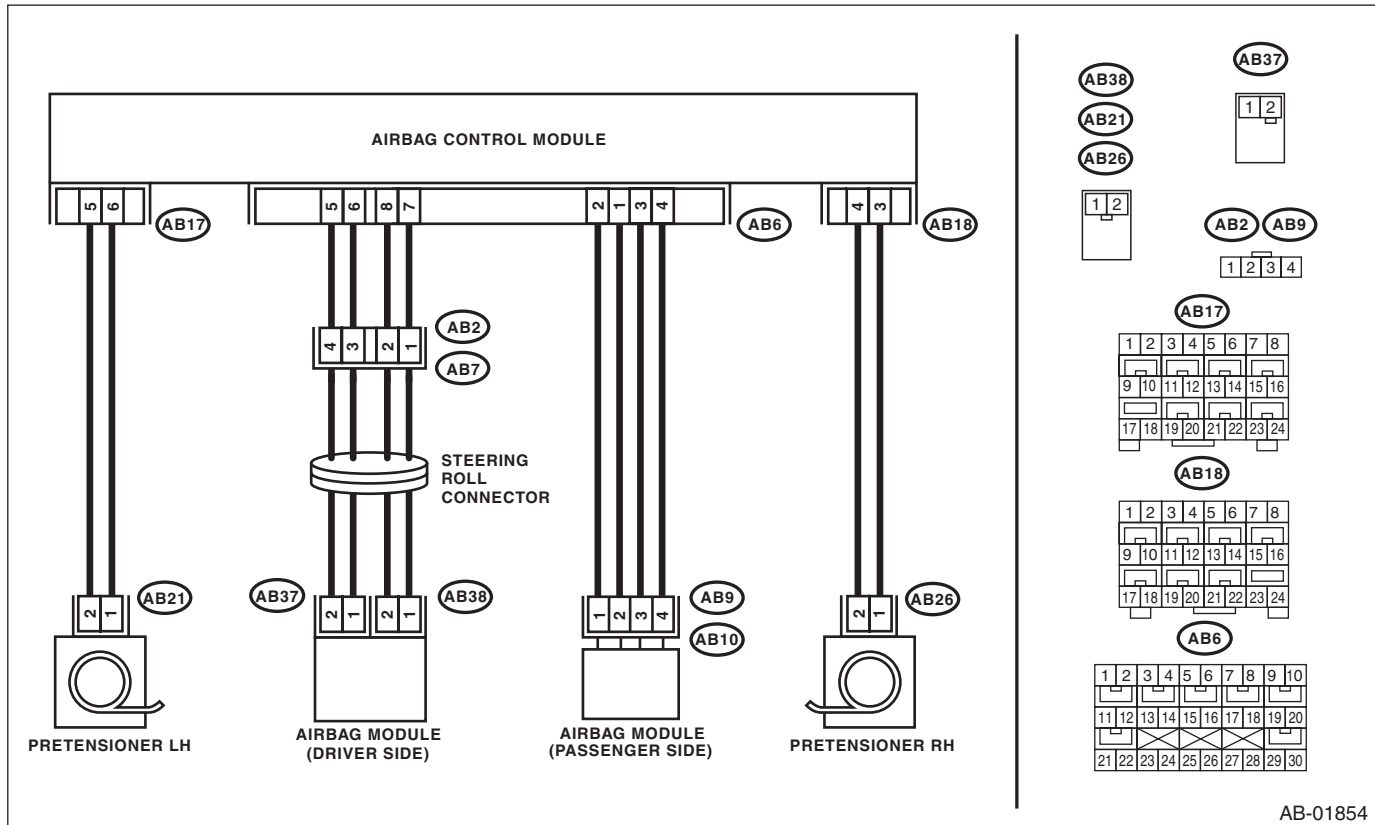

This DTC is indicated when the front airbag module and the pretensioner are deployed.

Once this DTC is displayed, the memory cannot be cleared. Therefore replace the following parts.

- Airbag control module <Ref. to AB-22, Airbag Control Module.>
- Driver's airbag module <Ref. to AB-16, Driver's Airbag Module.>
- Passenger's airbag module <Ref. to AB-17, Passenger's Airbag Module.>
- Front sub sensor of both sides <Ref. to AB-23, Front Sub Sensor.>
- Front outer seat belt with pretensioner of both sides <Ref. to SB-17, Front Seat Belt.>
- Steering roll connector <Ref. to AB-27, Roll Connector.>
- Occupant detection system (passenger's seat cushion & frame assembly) <Ref. to SE-6, Front Seat.>

Diagnostic Chart with Trouble Code

Brought to you by Eris Studios
NOT FOR RESALE

AIRBAG SYSTEM (DIAGNOSTICS)

G: DTC 26 PASSENGER'S AIRBAG INDICATOR FAILURE

DTC DETECTING CONDITION:

- Passenger's airbag indicator is faulty.
- Airbag control module is faulty.
- Airbag main harness circuit is open.
- Body harness circuit is open.

CAUTION:

- Before diagnosing the airbag system, be sure to turn the ignition switch to OFF, disconnect the ground terminal from battery, and wait 20 seconds or more before starting to work.
- When replacing the airbag module, seat belt pretensioner, roll connector, control module and sensor, reconnect each part and check that the warning light operates properly.
- When inspecting the airbag main harness, disconnect the airbag module connectors of the driver's and passenger's seats for safety.
- When inspecting the airbag rear harness, disconnect the side airbag module connector, curtain airbag module connector and seat belt pretensioner connector for safety reasons.

WIRING DIAGRAM:

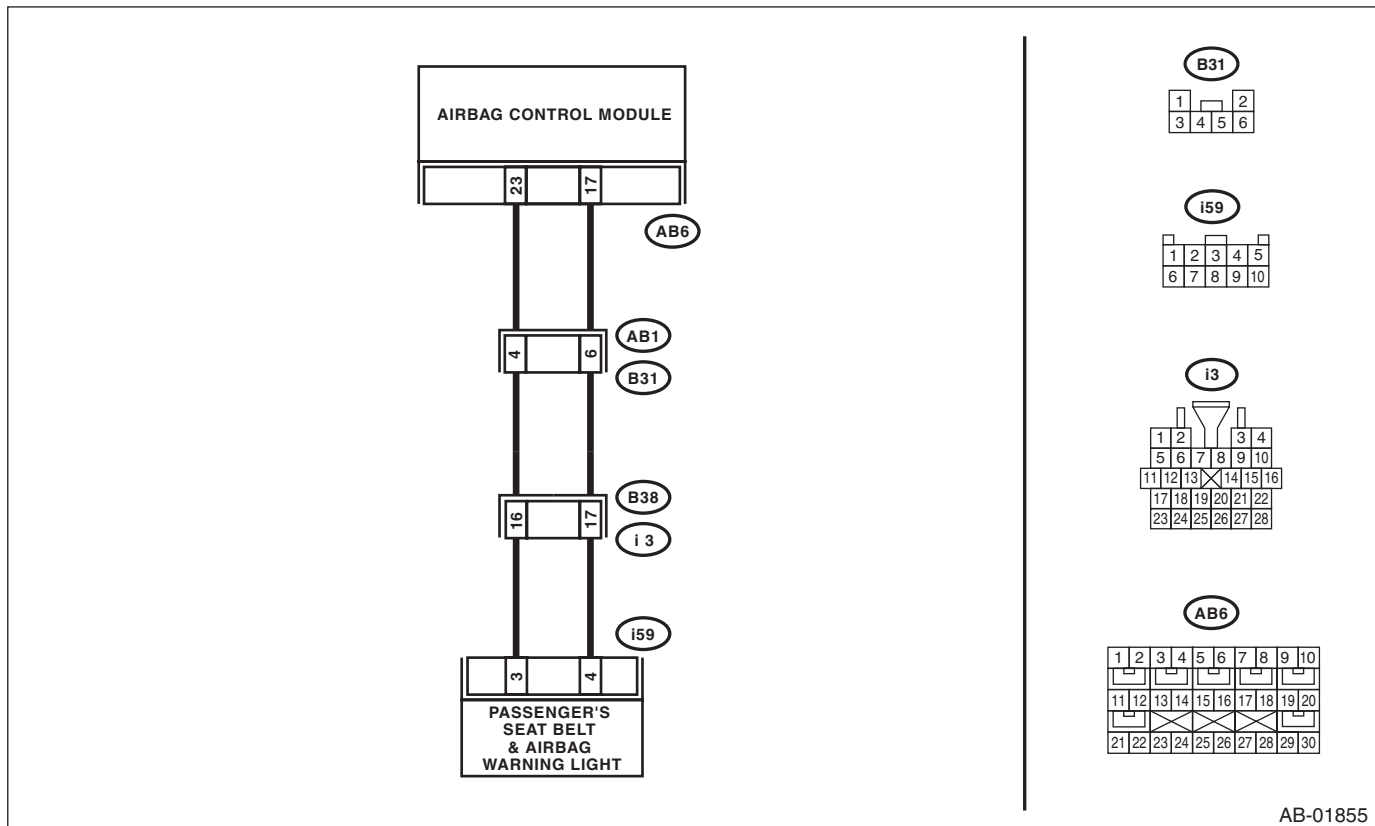

Diagnostic Chart with Trouble Code

AIRBAG SYSTEM (DIAGNOSTICS)

Brought to you by Eriss Studios
NOT FOR SALE

	Step	Check	Yes	No
1	CHECK POOR CONTACT. 1) Turn the ignition switch to OFF, disconnect the battery ground cable, and wait for 20 seconds or more. 2) Confirm that firm contact is secured for the connector between the airbag control module and the clock.	Is there poor contact in any connector?	Replace the airbag harness connector.	Go to step 2.
2	CHECK AIRBAG MAIN HARNESS. 1) Disconnect the connectors (AB6, AB17, and AB18) from airbag control module. 2) Connect the battery ground terminal and turn the ignition switch to ON. NOTE: Neither of ON/OFF illuminates when it is normal.	Does the passenger's airbag indicator illuminate?	Go to step 3.	Go to step 4.
3	CHECK AIRBAG MAIN HARNESS. 1) Turn the ignition switch to OFF. 2) Remove the clock and disconnect the connector (R150). 3) Connect the connector (1AG) in the test harness AG to the connectors (AB6, AB17, and AB18). 4) Measure the resistance between connector (2AG) in the test harness AG and chassis ground. Connector & terminal (2AG) No. 9 — (2AG) No. 8: (2AG) No. 9 — Chassis ground: (2AG) No. 8 — Chassis ground:	Is the resistance 1 MΩ or more?	Replace the clock. <Ref. to IDI-20, REMOVAL, Clock.>	Repair the bulk-head harness. Or replace the airbag main harness along with body harness.
4	CHECK AIRBAG HARNESS. 1) Connect the connectors (7AG) and (8AG) in the test harness AG. 2) Connect the battery ground terminal and turn the ignition switch to ON.	Does the passenger's airbag indicator illuminate?	Replace the airbag control module. <Ref. to AB-22, Airbag Control Module.>	Go to step 5.
5	CHECK AIRBAG HARNESS. 1) Turn the ignition switch to OFF. 2) Connect the connector (1AG) in the test harness AG to the connectors (AB6, AB17, and AB18). 3) Measure the resistance between connector (2AG) in the test harness AG and connector (i59). Connector & terminal (2AG) No. 9 — (i59) No. 4: (2AG) No. 8 — (i59) No. 3:	Is the resistance less than 10 Ω?	Go to step 6.	Repair the bulk-head harness. Or replace the airbag main harness along with body harness.
6	CHECK BODY HARNESS. 1) Turn the ignition switch to ON. 2) Measure the voltage between connector (i59) and chassis ground. Connector & terminal (i59) No. 8 — Chassis ground:	Is the voltage 10 V or more?	Replace the clock. <Ref. to IDI-20, REMOVAL, Clock.>	Repair the clock power supply line.

Diagnostic Chart with Trouble Code

AIRBAG SYSTEM (DIAGNOSTICS)

Brought to you by Eris Studios
NOT FOR RESALE

H: DTC 27 ODS COMMUNICATION ERROR

DTC DETECTING CONDITION:

- Communication to the occupant detection control module is faulty.
- Airbag rear harness circuit is open, shorted, shorted to ground or shorted to power supply.
- Occupant detection harness (seat harness) is faulty.
- Occupant detection system is faulty.
- Airbag control module is faulty.

Step	Check	Yes	No
1	CHECK POOR CONTACT IN CONNECTORS. Check for poor contact of the connectors between the airbag control module and the occupant detection control module.	Is there poor contact?	Reconnect the connector. If defective is not improved, replace the airbag rear harness along with the body harness or the occupant detection harness (seat harness).
2	CHECK AIRBAG HARNESS. 1) Turn the ignition switch to OFF, disconnect the battery ground cable, and wait for 20 seconds or more. 2) Disconnect the connectors (AB6, AB17, and AB18) from airbag control module. 3) Disconnect the connectors (AB59) and (AB53) under the passenger's seat. 4) Connect the connector (1AG) in the test harness AG to the connectors (AB6, AB17, and AB18). 5) Connect the connector (1AB) in the test harness AB to the connector (AB53). 6) Measure the resistance between connector (6AG) in the test harness AG and connector (2AB) in the test harness AB. <i>Connector & terminal</i> <i>(6AG) No. 9 — (2AB) No. 1:</i> <i>(6AG) No. 11 — (2AB) No. 2:</i>	Is the resistance less than 10 Ω?	Go to step 3. Replace the airbag rear harness along with body harness.
3	CHECK AIRBAG HARNESS. Measure the resistance between connector (6AG) in the test harness AG and chassis ground. <i>Connector & terminal</i> <i>(6AG) No. 9 — Chassis ground:</i> <i>(6AG) No. 9 — (6AG) No. 11:</i> <i>(6AG) No. 11 — Chassis ground:</i>	Is the resistance less than 1 MΩ?	Go to step 4. Replace the airbag rear harness along with body harness.
4	CHECK AIRBAG HARNESS. 1) Turn the ignition switch to ON. 2) Measure the voltage between connector (2AB) in the test harness AB and chassis ground. <i>Connector & terminal</i> <i>(2AB) No. 3 — chassis ground:</i>	Is the voltage 9 V or more?	Replace the occupant detection harness (seat harness). If defective is not improved, replace the occupant detection system (seat cushion & frame assembly), and then the airbag control module in this order. Check the battery voltage and fuse. If there is no fault, replace the airbag rear harness along with body harness or replace the body harness.

I: DTC 29 ODS FAILURE

NOTE:

Refer to “Occupant Detection System” for details on DTC 29. <Ref. to OD(diag)-26, DTC 29 ODS FAILURE, Diagnostic Procedure with Diagnostic Trouble Code (DTC).>

J: DTC 2A ODS CALIBRATION ERROR

NOTE:

Refer to “Occupant Detection System” for details on DTC 2A. <Ref. to OD(diag)-23, DTC 2A ODS CALIBRATION ERROR, Diagnostic Procedure with Diagnostic Trouble Code (DTC).>

K: DTC 2B ODS SYSTEM WRONG PARTS

NOTE:

Refer to “Occupant Detection System” for details on DTC 2B. <Ref. to OD(diag)-23, DTC 2B ODS SYSTEM WRONG PARTS, Diagnostic Procedure with Diagnostic Trouble Code (DTC).>

L: DTC 2C BELT TENSION SENSOR FAILURE

NOTE:

Refer to “Occupant Detection System” for details on DTC 2C. <Ref. to OD(diag)-24, DTC 2C BELT TENSION SENSOR FAILURE, Diagnostic Procedure with Diagnostic Trouble Code (DTC).>

M: DTC 33 FRONT SUB SENSOR RH FAILURE

DTC DETECTING CONDITION:

Front sub sensor (RH) is faulty.

If DTC 33 is displayed, the circuit within the front sub sensor (RH) is faulty.

Replace the front sub sensor (RH). <Ref. to AB-23, Front Sub Sensor.>

N: DTC 34 FRONT SUB SENSOR LH FAILURE

DTC DETECTING CONDITION:

Front sub sensor (LH) is faulty.

If DTC 34 is displayed, the circuit within the front sub sensor (LH) is faulty.

Replace the front sub sensor (LH). <Ref. to AB-23, Front Sub Sensor.>

O: DTC 37 BUCKLE SWITCH RH FAILURE

NOTE:

Refer to “Occupant Detection System” for details on DTC 37. <Ref. to OD(diag)-27, DTC 37 BUCKLE SWITCH RH FAILURE, Diagnostic Procedure with Diagnostic Trouble Code (DTC).>

Diagnostic Chart with Trouble Code

Brought to you by Eris Studios
NOT FOR RESALE

AIRBAG SYSTEM (DIAGNOSTICS)

P: DTC 39 SEAT BELT WARNING FAILURE

DTC DETECTING CONDITION:

- Airbag control module is faulty.
- Body integrated unit is faulty.
- Harness circuits between body integrated unit and airbag control module are open, shorted or shorted to ground.

CAUTION:

- Before diagnosing the airbag system, be sure to turn the ignition switch to OFF, disconnect the ground terminal from battery, and wait 20 seconds or more before starting to work.
- When replacing the airbag module, seat belt pretensioner, roll connector, control module and sensor, reconnect each part and check that the warning light operates properly.
- When inspecting the airbag main harness, disconnect the airbag module connectors of the driver's and passenger's seats for safety.
- When inspecting the airbag rear harness, disconnect the side airbag module connector, curtain airbag module connector and seat belt pretensioner connector for safety reasons.

WIRING DIAGRAM:

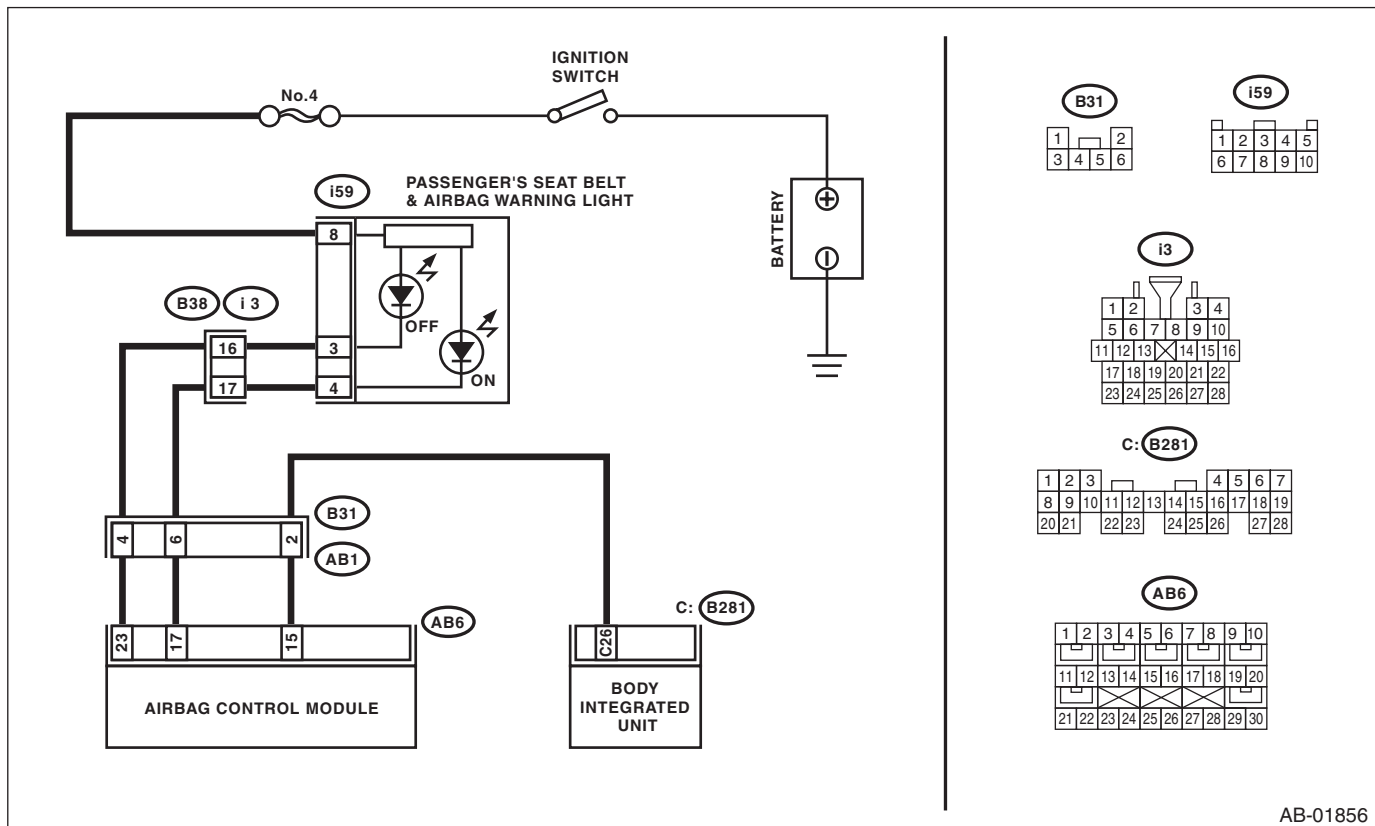

AB-01856

Diagnostic Chart with Trouble Code

AIRBAG SYSTEM (DIAGNOSTICS)

Brought to you by Eris Studios
NOT FOR RESALE

Step	Check	Yes	No
1 CHECK AIRBAG HARNESS. 1) Turn the ignition switch to OFF, disconnect the battery ground cable, and wait for 20 seconds or more. 2) Disconnect the connectors (AB6, AB17, and AB18) from airbag control module. 3) Connect the battery ground terminal and turn the ignition switch to ON.	Does the passenger's seat belt warning light blink for 6 seconds and go off?	Go to step 3.	Go to step 2.
2 CHECK AIRBAG HARNESS. 1) Turn the ignition switch to OFF. 2) Connect the connector (1AG) in the test harness AG to the connectors (AB6, AB17, and AB18). 3) Measure the resistance between connector (2AG) in the test harness AG and chassis ground. <i>Connector & terminal (2AG) No. 10 — Chassis ground:</i>	Is the resistance 1 MΩ or more?	Replace the body integrated unit.	Repair the bulk-head harness. Or replace the airbag main harness along with body harness.
3 CHECK AIRBAG HARNESS. 1) Connect the connectors (7AG) and (8AG) in the test harness AG in the condition of step 2. 2) Turn the ignition switch to ON.	Does the passenger's seat belt warning light blink for 6 seconds, then repeatedly light and go off?	Replace the airbag control module. <Ref. to AB-22, Airbag Control Module.>	Go to step 4.
4 CHECK AIRBAG HARNESS. 1) Disconnect the connectors (7AG) and (8AG) in the test harness AG in the condition of step 3. 2) Measure the resistance between connector (2AG) in the test harness AG and connector (B281). <i>Connector & terminal (2AG) No. 10 — (B281) No. 26:</i>	Is the resistance less than 10 Ω?	Replace the body integrated unit.	Repair the bulk-head harness. Or replace the airbag main harness along with body harness.

Diagnostic Chart with Trouble Code

Brought to you by Eris Studios
NOT FOR RESALE

AIRBAG SYSTEM (DIAGNOSTICS)

Q: DTC 41 SIDE AIRBAG RH FAILURE

DTC DETECTING CONDITION:

- Side airbag harness (RH) is faulty.
- Side airbag module (RH) is faulty.
- Airbag control module is faulty.

CAUTION:

- Before diagnosing the airbag system, be sure to turn the ignition switch to OFF, disconnect the ground terminal from battery, and wait 20 seconds or more before starting to work.
- When replacing the airbag module, seat belt pretensioner, roll connector, control module and sensor, reconnect each part and check that the warning light operates properly.
- When inspecting the airbag main harness, disconnect the airbag module connectors of the driver's and passenger's seats for safety.
- When inspecting the airbag rear harness, disconnect the side airbag module connector, curtain airbag module connector and seat belt pretensioner connector for safety reasons.

WIRING DIAGRAM:

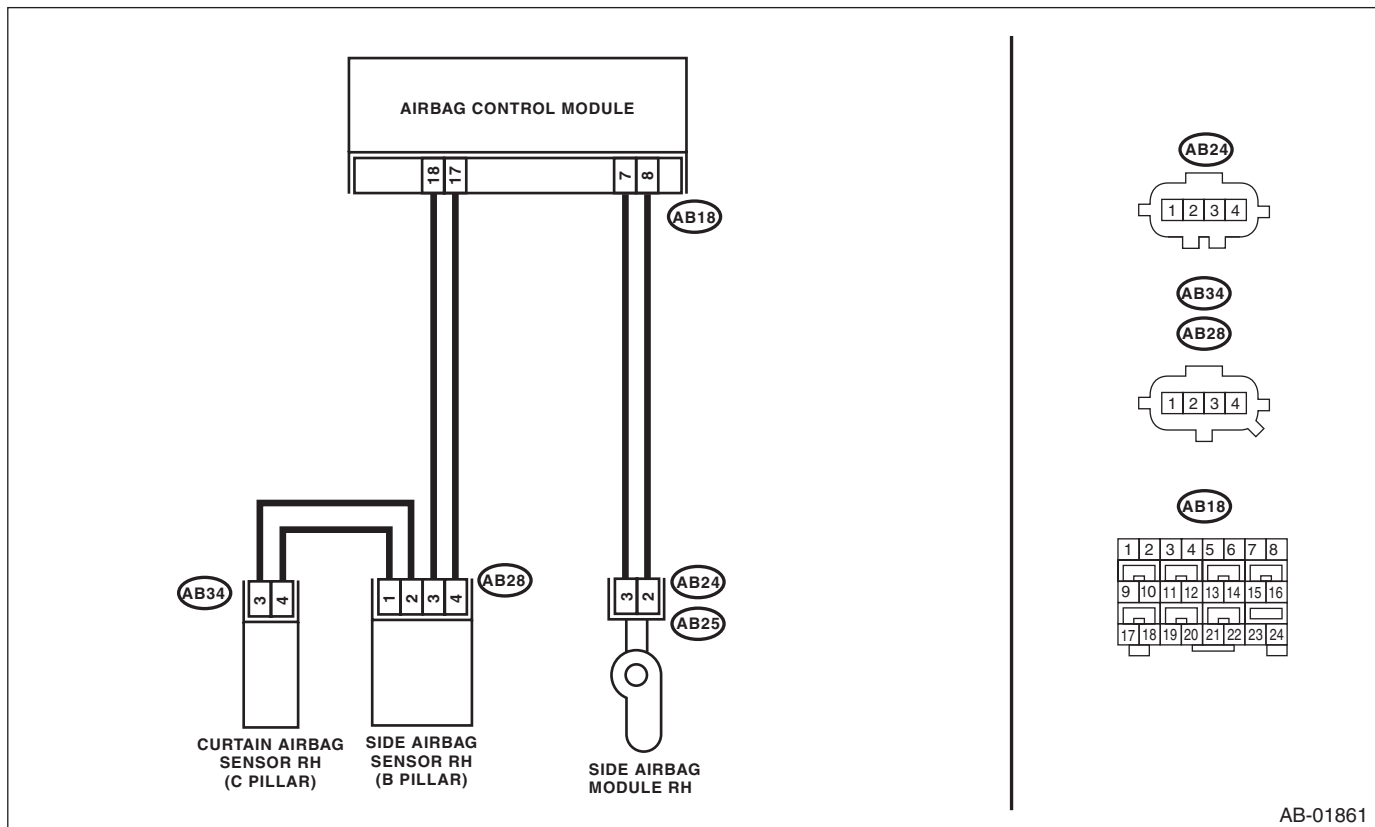

AB-01861

Step	Check	Yes	No	
1	CHECK POOR CONTACT IN CONNECTORS. Check for poor contact of the connectors between the airbag control module, side airbag module RH and the side airbag sensor RH.	Is there poor contact?	Replace the airbag rear harness along with body harness.	Go to step 2.

Diagnostic Chart with Trouble Code

AIRBAG SYSTEM (DIAGNOSTICS)

Brought to you by Eris Studios
NOT FOR SALE

Step	Check	Yes	No
2 CHECK SIDE AIRBAG MODULE. 1) Turn the ignition switch to OFF, disconnect the battery ground cable, and wait for 20 seconds or more. 2) Disconnect the connectors (AB25) and (AB24), and connect the connector (1AJ) in test harness AJ to connector (AB24). 3) Connect the airbag resistor to the connector (3AJ) of test harness AJ. 4) Connect the battery ground terminal and turn the ignition switch to ON.	Does the airbag warning light illuminate for 6 seconds and go off?	Replace the side airbag module (RH). <Ref. to AB-18, REMOVAL, Side Airbag Module.>	Go to step 3.
3 CHECK AIRBAG REAR HARNESS (SIDE AIRBAG MODULE HARNESS RH). 1) Turn the ignition switch to OFF, disconnect the battery ground cable, and wait for 20 seconds or more. 2) Disconnect the connector (AB26) from seat belt pretensioner (RH). 3) Disconnect the connector (AB33) from curtain airbag module (RH). 4) Disconnect the airbag resistor from test harness AJ. 5) Disconnect the connectors (AB6, AB17, and AB18) from airbag control module. 6) Connect the connector (1AG) in the test harness AG to the connectors (AB6, AB17, and AB18). 7) Measure the resistance between connector (5AG) in the test harness AG and connector (3AJ) in the test harness AJ. <i>Connector & terminal</i> <i>(5AG) No. 5 — (3AJ) No. 2:</i> <i>(5AG) No. 7 — (3AJ) No. 1:</i>	Is the resistance less than 10 Ω?	Go to step 4.	Replace the airbag rear harness along with body harness.
4 CHECK AIRBAG REAR HARNESS (SIDE AIRBAG MODULE HARNESS RH). Measure the resistance between connector (5AG) terminals in the test harness AG. <i>Connector & terminal</i> <i>(5AG) No. 5 — (5AG) No. 7:</i>	Is the resistance 1 MΩ or more?	Go to step 5.	Replace the airbag rear harness along with body harness.
5 CHECK AIRBAG REAR HARNESS (SIDE AIRBAG MODULE HARNESS RH). Measure the resistance between connector (5AG) in the test harness AG and chassis ground. <i>Connector & terminal</i> <i>(5AG) No. 5 — Chassis ground:</i> <i>(5AG) No. 7 — Chassis ground:</i>	Is the resistance 1 MΩ or more?	Go to step 6.	Replace the airbag rear harness along with body harness.
6 CHECK AIRBAG CONTROL MODULE. 1) Connect all connectors. 2) Erase the memory. 3) Perform the Inspection Mode. 4) Read the DTC.	Is the same DTC displayed?	Replace the airbag control module. <Ref. to AB-22, Airbag Control Module.>	Go to step 7.
7 CHECK FOR ANY OTHER DTC ON DISPLAY.	Is any other DTC displayed?	Check DTC using "List of Diagnostic Trouble Code (DTC)". <Ref. to AB(diag)-42, List of Diagnostic Trouble Code (DTC).>	Finish the diagnosis.

Diagnostic Chart with Trouble Code

AIRBAG SYSTEM (DIAGNOSTICS)

Brought to you by Eris Studios
NOT FOR RESALE

R: DTC 42 SIDE AIRBAG LH FAILURE

DTC DETECTING CONDITION:

- Side airbag harness (LH) is faulty.
- Side airbag module (LH) is faulty.
- Airbag control module is faulty.

CAUTION:

- Before diagnosing the airbag system, be sure to turn the ignition switch to OFF, disconnect the ground terminal from battery, and wait 20 seconds or more before starting to work.
- When replacing the airbag module, seat belt pretensioner, roll connector, control module and sensor, reconnect each part and check that the warning light operates properly.
- When inspecting the airbag main harness, disconnect the airbag module connectors of the driver's and passenger's seats for safety.
- When inspecting the airbag rear harness, disconnect the side airbag module connector, curtain airbag module connector and seat belt pretensioner connector for safety reasons.

WIRING DIAGRAM:

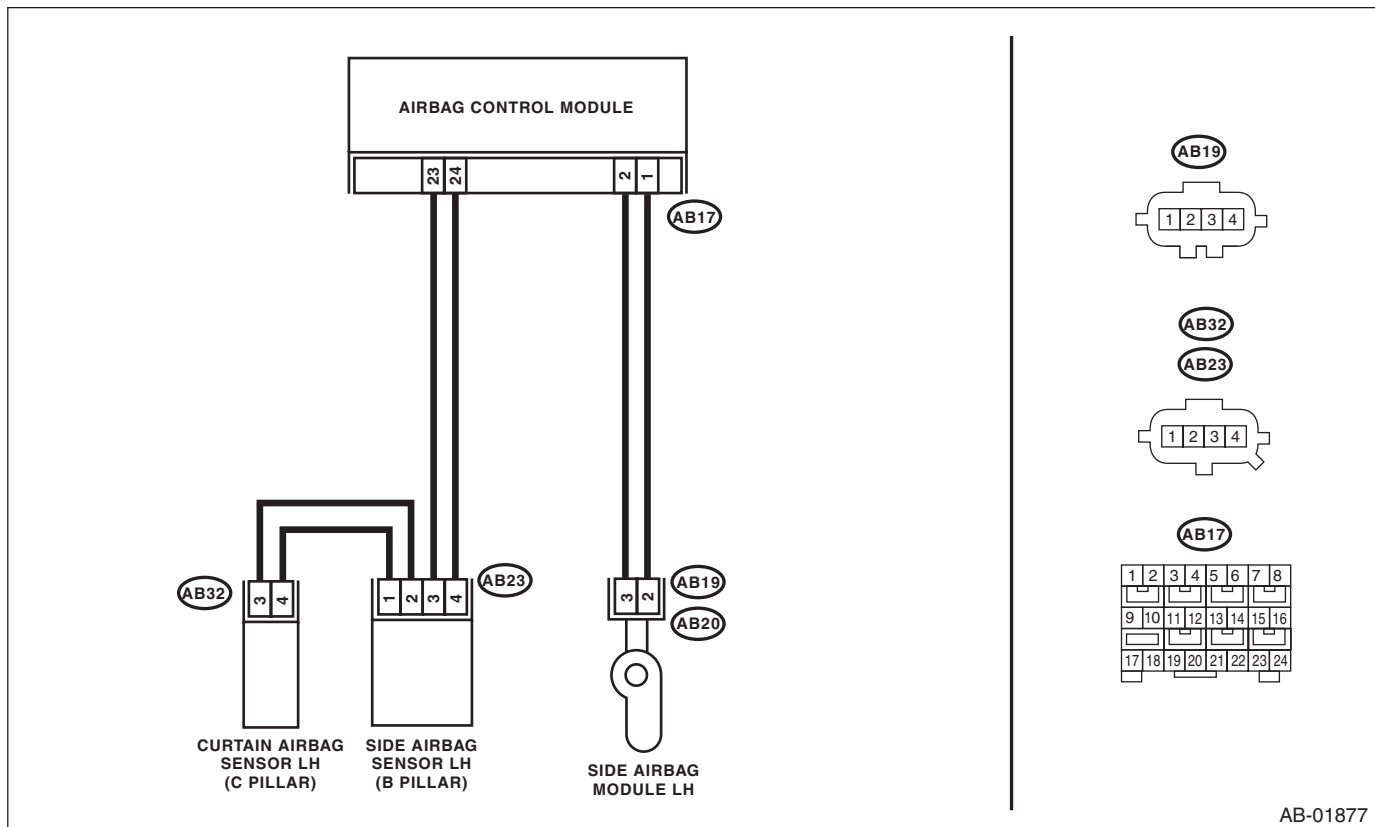

AB-01877

Step	Check	Yes	No	
1	CHECK POOR CONTACT IN CONNECTORS. Check for poor contact of the connectors between the airbag control module, side airbag module LH and the side airbag sensor LH.	Is there poor contact?	Replace the airbag rear harness along with body harness.	Go to step 2.

Diagnostic Chart with Trouble Code

AIRBAG SYSTEM (DIAGNOSTICS)

Brought to you by Eris Studios
NOT FOR SALE

Step	Check	Yes	No
2 CHECK SIDE AIRBAG MODULE. 1) Turn the ignition switch to OFF, disconnect the battery ground cable, and wait for 20 seconds or more. 2) Disconnect the connectors (AB20) and (AB19), and connect the connector (1AJ) in test harness AJ to connector (AB19). 3) Connect the airbag resistor to the connector (3AJ) of test harness AJ. 4) Connect the battery ground terminal and turn the ignition switch to ON.	Does the airbag warning light illuminate for 6 seconds and go off?	Replace the side airbag module (LH). <Ref. to AB-18, REMOVAL, Side Airbag Module.>	Go to step 3.
3 CHECK AIRBAG REAR HARNESS (SIDE AIRBAG MODULE HARNESS LH). 1) Turn the ignition switch to OFF, disconnect the battery ground cable, and wait for 20 seconds or more. 2) Disconnect the connector (AB21) from seat belt pretensioner (LH). 3) Disconnect the connector (AB31) from curtain airbag module (LH). 4) Disconnect the airbag resistor from test harness. 5) Disconnect the connectors (AB6, AB17, and AB18) from airbag control module. 6) Connect the connector (1AG) in the test harness AG to the connectors (AB6, AB17, and AB18). 7) Measure the resistance between connector (5AG) in the test harness AG and connector (3AJ) in the test harness AJ. <i>Connector & terminal</i> <i>(5AG) No. 1 — (3AJ) No. 1:</i> <i>(5AG) No. 3 — (3AJ) No. 2:</i>	Is the resistance less than 10 Ω?	Go to step 4.	Replace the airbag rear harness along with body harness.
4 CHECK AIRBAG REAR HARNESS (SIDE AIRBAG MODULE HARNESS LH). Measure the resistance between connector (5AG) terminals in the test harness AG. <i>Connector & terminal</i> <i>(5AG) No. 1 — (5AG) No. 3:</i>	Is the resistance 1 MΩ or more?	Go to step 5.	Replace the airbag rear harness along with body harness.
5 CHECK AIRBAG REAR HARNESS (SIDE AIRBAG MODULE HARNESS LH). Measure the resistance between connector (5AG) in the test harness AG and chassis ground. <i>Connector & terminal</i> <i>(5AG) No. 1 — Chassis ground:</i> <i>(5AG) No. 3 — Chassis ground:</i>	Is the resistance 1 MΩ or more?	Go to step 6.	Replace the airbag rear harness along with body harness.
6 CHECK AIRBAG CONTROL MODULE. 1) Connect all connectors. 2) Erase the memory. 3) Perform the Inspection Mode. 4) Read the DTC.	Is the same DTC displayed?	Replace the airbag control module. <Ref. to AB-22, Airbag Control Module.>	Go to step 7.
7 CHECK FOR ANY OTHER DTC ON DISPLAY.	Is any other DTC displayed?	Check DTC using “List of Diagnostic Trouble Code (DTC)”. <Ref. to AB(diag)-42, List of Diagnostic Trouble Code (DTC).>	Finish the diagnosis.

Diagnostic Chart with Trouble Code

Brought to you by Eris Studios
NOT FOR RESALE

AIRBAG SYSTEM (DIAGNOSTICS)

S: DTC 45 SIDE AIRBAG RH FAILURE

DTC DETECTING CONDITION:

- Side airbag harness (RH) is shorted to power supply.
- Airbag control module is faulty.

CAUTION:

- Before diagnosing the airbag system, be sure to turn the ignition switch to OFF, disconnect the ground terminal from battery, and wait 20 seconds or more before starting to work.
- When replacing the airbag module, seat belt pretensioner, roll connector, control module and sensor, reconnect each part and check that the warning light operates properly.
- When inspecting the airbag main harness, disconnect the airbag module connectors of the driver's and passenger's seats for safety.
- When inspecting the airbag rear harness, disconnect the side airbag module connector, curtain airbag module connector and seat belt pretensioner connector for safety reasons.

WIRING DIAGRAM:

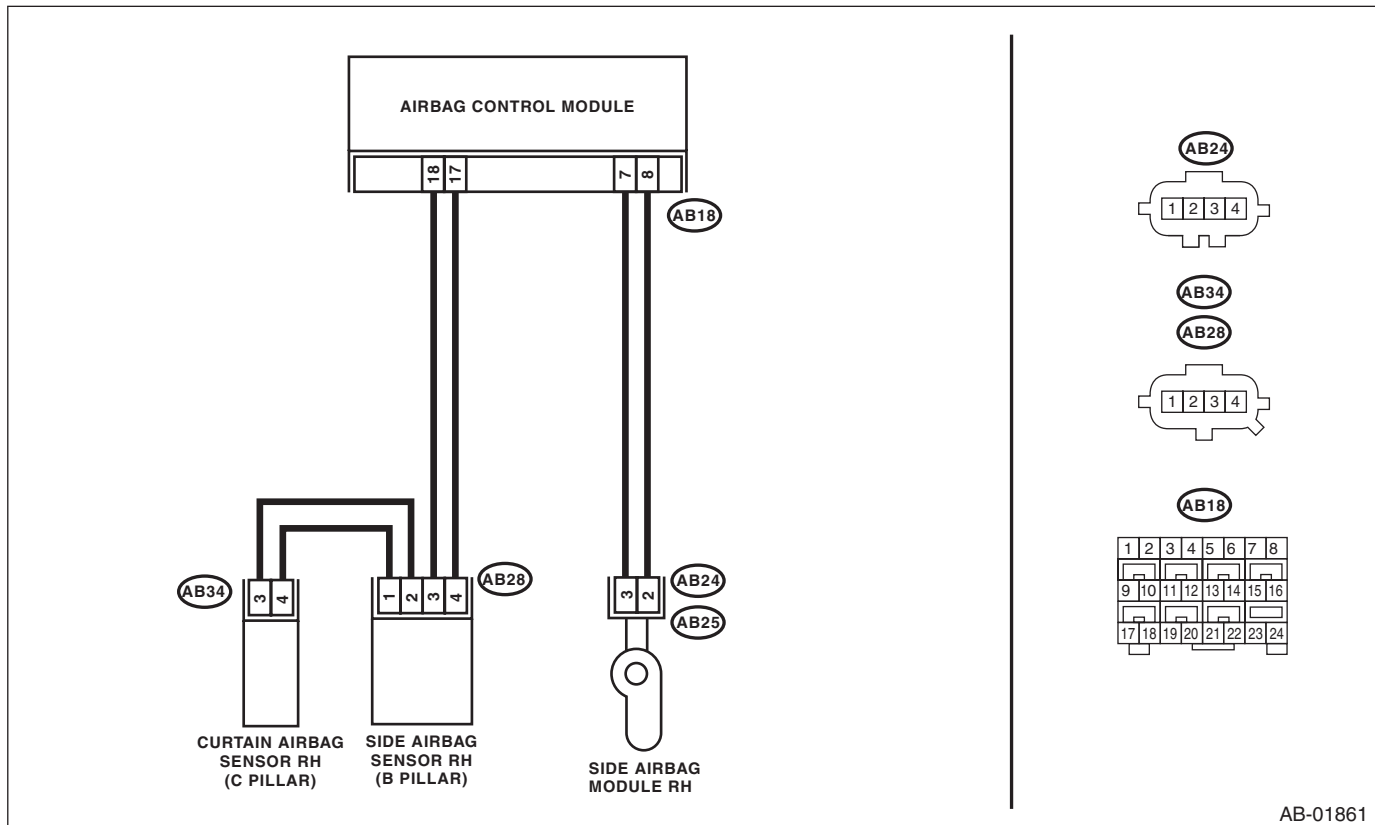

AB-01861

Diagnostic Chart with Trouble Code

AIRBAG SYSTEM (DIAGNOSTICS)

Brought to you by Eris Studios
NOT FOR SALE

	Step	Check	Yes	No
1	CHECK POOR CONTACT IN CONNECTORS. Check for poor contact of the connectors between the airbag control module, side airbag module RH and the side airbag sensor RH.	Is there poor contact?	Replace the airbag rear harness along with body harness.	Go to step 2.
2	CHECK SIDE AIRBAG MODULE. 1) Turn the ignition switch to OFF, disconnect the battery ground cable, and wait for 20 seconds or more. 2) Disconnect the connectors (AB25) and (AB24), and connect the connector (1AJ) in test harness AJ to connector (AB24). 3) Connect the airbag resistor to the connector (3AJ) of test harness AJ. 4) Connect the battery ground terminal and turn the ignition switch to ON.	Does the airbag warning light illuminate for 6 seconds and go off?	Replace the side airbag module (RH). <Ref. to AB-18, REMOVAL, Side Airbag Module.>	Go to step 3.
3	CHECK AIRBAG REAR HARNESS (SIDE AIRBAG MODULE HARNESS RH). 1) Turn the ignition switch to OFF, disconnect the battery ground cable, and wait for 20 seconds or more. 2) Disconnect the connector (AB26) from seat belt pretensioner (RH). 3) Disconnect the connector (AB33) from curtain airbag module (RH). 4) Disconnect the airbag resistor from test harness. 5) Disconnect the connectors (AB6, AB17, and AB18) from airbag control module. 6) Connect the connector (1AG) in the test harness AG to the connectors (AB6, AB17, and AB18). 7) Connect the battery ground terminal and turn the ignition switch to ON. 8) Measure the voltage between connector (5AG) in the test harness AG and chassis ground. Connector & terminal (5AG) No. 5 (+) — Chassis ground (-): (5AG) No. 7 (+) — Chassis ground (-):	Is the voltage less than 1 V?	Go to step 4.	Replace the airbag rear harness along with body harness.
4	CHECK AIRBAG CONTROL MODULE. 1) Connect all connectors. 2) Erase the memory. 3) Perform the Inspection Mode. 4) Read the DTC.	Is the same DTC displayed?	Replace the airbag control module. <Ref. to AB-22, Airbag Control Module.>	Go to step 5.
5	CHECK FOR ANY OTHER DTC ON DISPLAY.	Is any other DTC displayed?	Check DTC using "List of Diagnostic Trouble Code (DTC)". <Ref. to AB(diag)-42, List of Diagnostic Trouble Code (DTC).>	Finish the diagnosis.

Diagnostic Chart with Trouble Code

Brought to you by Eris Studios
NOT FOR RESALE

AIRBAG SYSTEM (DIAGNOSTICS)

T: DTC 46 SIDE AIRBAG LH FAILURE

DTC DETECTING CONDITION:

- Side airbag harness (LH) is shorted to power supply.
- Airbag control module is faulty.

CAUTION:

- Before diagnosing the airbag system, be sure to turn the ignition switch to OFF, disconnect the ground terminal from battery, and wait 20 seconds or more before starting to work.
- When replacing the airbag module, seat belt pretensioner, roll connector, control module and sensor, reconnect each part and check that the warning light operates properly.
- When inspecting the airbag main harness, disconnect the airbag module connectors of the driver's and passenger's seats for safety.
- When inspecting the airbag rear harness, disconnect the side airbag module connector, curtain airbag module connector and seat belt pretensioner connector for safety reasons.

WIRING DIAGRAM:

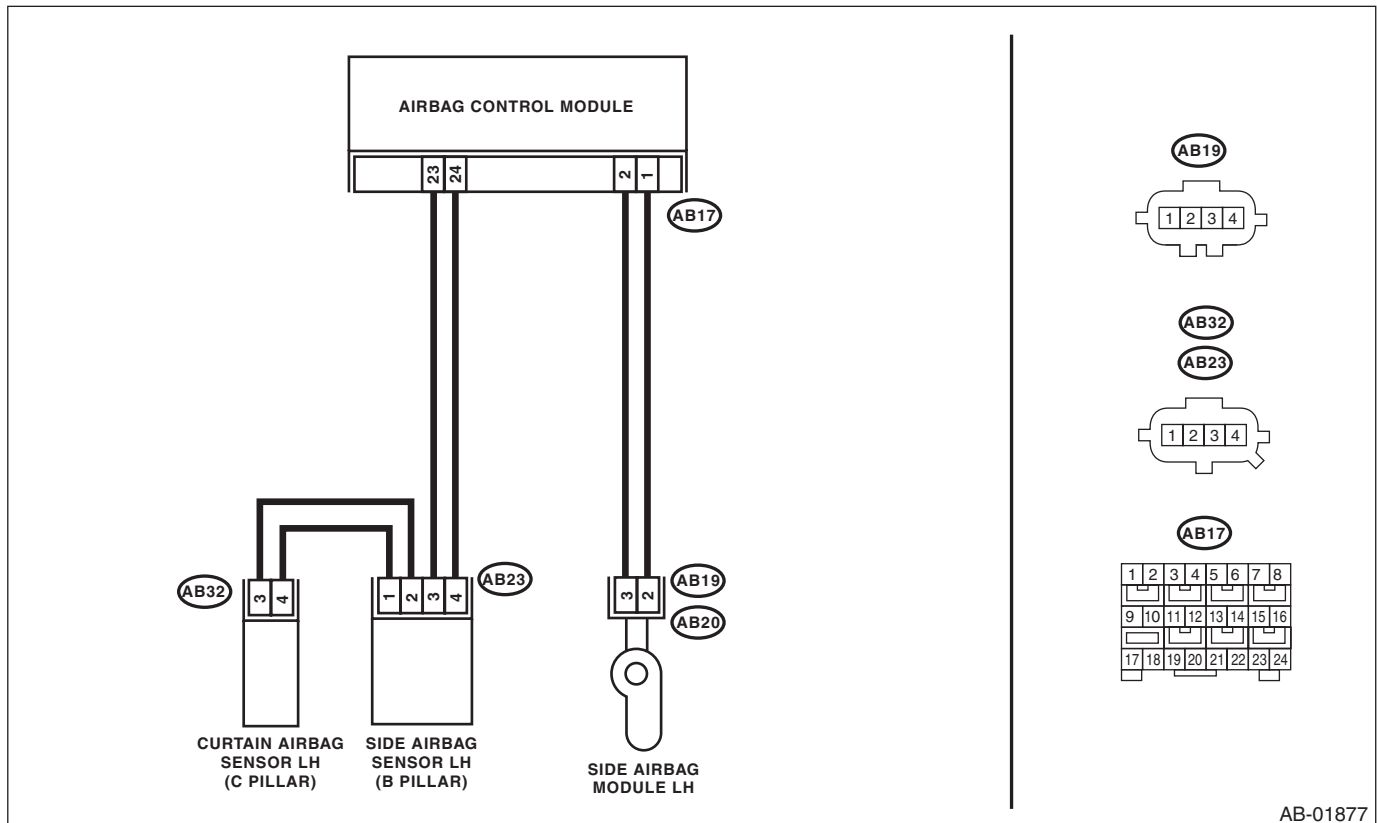

AB-01877

Diagnostic Chart with Trouble Code

AIRBAG SYSTEM (DIAGNOSTICS)

Brought to you by Eris Studios
NOT FOR SALE

	Step	Check	Yes	No
1	CHECK POOR CONTACT IN CONNECTORS. Check for poor contact of the connectors between the airbag control module, side airbag module LH and the side airbag sensor LH.	Is there poor contact?	Replace the airbag rear harness along with body harness.	Go to step 2.
2	CHECK SIDE AIRBAG MODULE. 1) Turn the ignition switch to OFF, disconnect the battery ground cable, and wait for 20 seconds or more. 2) Disconnect the connectors (AB20) and (AB19), and connect the connector (1AJ) in test harness AJ to connector (AB19). 3) Connect the airbag resistor to the connector (3AJ) of test harness AJ. 4) Connect the battery ground terminal and turn the ignition switch to ON.	Does the airbag warning light illuminate for 6 seconds and go off?	Replace the side airbag module (LH). <Ref. to AB-18, REMOVAL, Side Airbag Module.>	Go to step 3.
3	CHECK AIRBAG REAR HARNESS (SIDE AIRBAG MODULE HARNESS LH). 1) Turn the ignition switch to OFF, disconnect the battery ground cable, and wait for 20 seconds or more. 2) Disconnect the connector (AB21) from seat belt pretensioner (LH). 3) Disconnect the connector (AB31) from curtain airbag module (LH). 4) Disconnect the airbag resistor from test harness. 5) Disconnect the connectors (AB6, AB17, and AB18) from airbag control module. 6) Connect the connector (1AG) in the test harness AG to the connectors (AB6, AB17, and AB18). 7) Connect the battery ground terminal and turn the ignition switch to ON. 8) Measure the voltage between connector (5AG) in the test harness AG and chassis ground. Connector & terminal (5AG) No. 3 (+) — Chassis ground (-): (5AG) No. 1 (+) — Chassis ground (-):	Is the voltage less than 1 V?	Go to step 4.	Replace the airbag rear harness along with body harness.
4	CHECK AIRBAG CONTROL MODULE. 1) Connect all connectors. 2) Erase the memory. 3) Perform the Inspection Mode. 4) Read the DTC.	Is the same DTC displayed?	Replace the airbag control module. <Ref. to AB-22, Airbag Control Module.>	Go to step 5.
5	CHECK FOR ANY OTHER DTC ON DISPLAY.	Is any other DTC displayed?	Check DTC using "List of Diagnostic Trouble Code (DTC)". <Ref. to AB(diag)-42, List of Diagnostic Trouble Code (DTC).>	Finish the diagnosis.

Diagnostic Chart with Trouble Code

AIRBAG SYSTEM (DIAGNOSTICS)

Brought to you by Eris Studios
NOT FOR RESALE

U: DTC 53 SIDE AIRBAG SENSOR RH FAILURE

DTC DETECTING CONDITION:

Side airbag sensor (RH) is faulty.

When DTC 53 is displayed, the circuit within the side airbag sensor (RH) is faulty.

Replace the side airbag sensor (RH). <Ref. to AB-24, Side Airbag Sensor.>

V: DTC 54 SIDE AIRBAG SENSOR LH FAILURE

DTC DETECTING CONDITION:

Side airbag sensor (LH) is faulty.

When DTC 54 is displayed, the circuit within the side airbag sensor (LH) is faulty.

Replace the side airbag sensor (LH). <Ref. to AB-24, Side Airbag Sensor.>

W: DTC 55 SIDE CURTAIN AIRBAG FIRING OUTPUT

This DTC is displayed when the side airbag module and curtain airbag module are deployed.

Once this DTC is displayed, the memory cannot be cleared. Replace the following parts.

- Airbag control module <Ref. to AB-22, Airbag Control Module.>
- Front seat with side airbag module (Operating side) <Ref. to SE-6, Front Seat.>
- Side airbag sensor (Operating side) <Ref. to AB-24, Side Airbag Sensor.>
- Curtain airbag module (Operating side) <Ref. to AB-20, Curtain Airbag Module.>
- Curtain airbag sensor (Operating side) <Ref. to AB-25, Curtain Airbag Sensor.>
- Satellite safing sensor <Ref. to AB-26, Satellite Safing Sensor.>

X: DTC 58 CURTAIN AIRBAG SENSOR RH FAILURE

DTC DETECTING CONDITION:

Curtain airbag sensor (RH) is faulty.

If DTC 58 is displayed, the circuit within the curtain airbag sensor (RH) is faulty.

Replace the curtain airbag sensor (RH). <Ref. to AB-25, Curtain Airbag Sensor.>

Y: DTC 59 CURTAIN AIRBAG SENSOR LH FAILURE

DTC DETECTING CONDITION:

Curtain airbag sensor (LH) is faulty.

If DTC 59 is displayed, the circuit within the curtain airbag sensor (LH) is faulty.

Replace the curtain airbag sensor (LH). <Ref. to AB-25, Curtain Airbag Sensor.>

Diagnostic Chart with Trouble Code

AIRBAG SYSTEM (DIAGNOSTICS)

Brought to you by Eris Studios
NOT FOR SALE

Z: DTC 61 BELT PRETENSIONER RH FAILURE

DTC DETECTING CONDITION:

- Seat belt pretensioner (RH) circuit is open, shorted or shorted to ground.
- Airbag control module is faulty.
- Pretensioner is faulty.
- Pretensioner harness is faulty.

CAUTION:

- Before diagnosing the airbag system, be sure to turn the ignition switch to OFF, disconnect the ground terminal from battery, and wait 20 seconds or more before starting to work.
- When replacing the airbag module, seat belt pretensioner, roll connector, control module and sensor, reconnect each part and check that the warning light operates properly.
- When inspecting the airbag main harness, disconnect the airbag module connectors of the driver's and passenger's seats for safety.
- When inspecting the airbag rear harness, disconnect the side airbag module connector, curtain airbag module connector and seat belt pretensioner connector for safety reasons.

WIRING DIAGRAM:

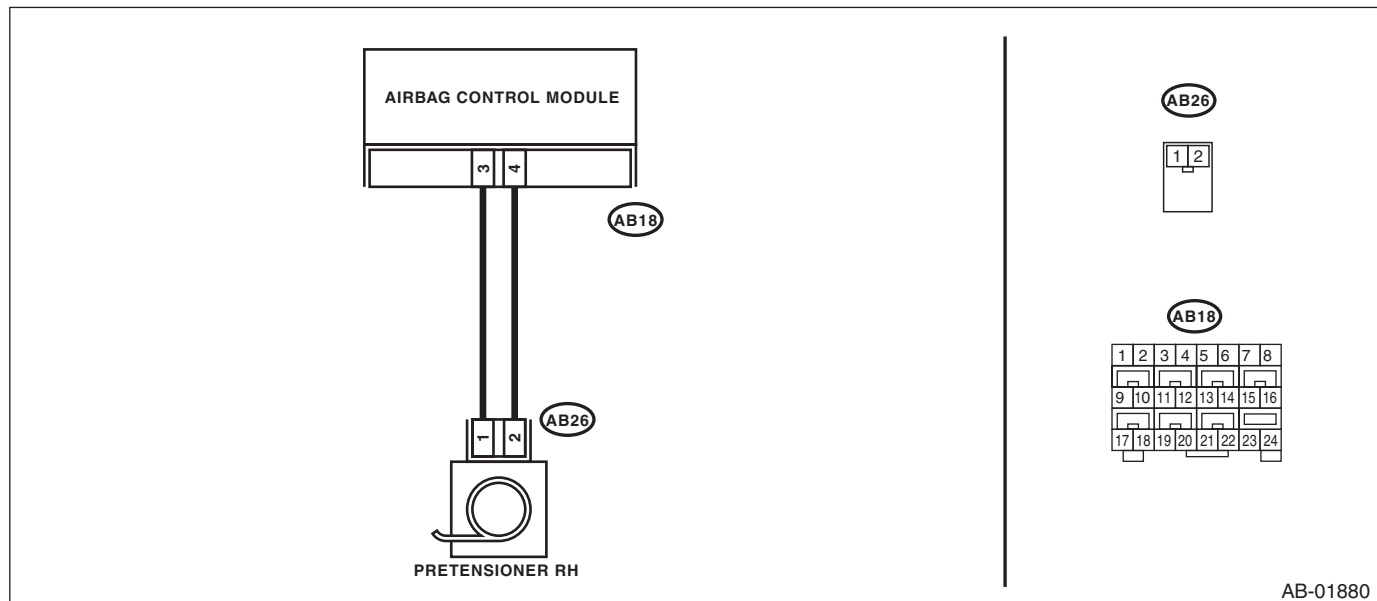

AB-01880

Step	Check	Yes	No
1 CHECK POOR CONTACT IN CONNECTORS. Check for poor contact of the connectors between the airbag control module and the seat belt pretensioner RH.	Is there poor contact?	Replace the airbag rear harness along with body harness.	Go to step 2.
2 CHECK SEAT BELT PRETENSIONER. 1) Turn the ignition switch to OFF, disconnect the battery ground cable, and wait for 20 seconds or more. 2) Disconnect the connector (AB26) from seat belt pretensioner (RH). 3) Connect the connector (1N) in the test harness N to the connector (AB26). 4) Connect the airbag resistor to the connector (2N) of test harness N. 5) Connect the battery ground terminal and turn the ignition switch to ON.	Does the airbag warning light illuminate for 6 seconds and go off?	Replace the seat belt pretensioner (RH). <Ref. to SB-17, Front Seat Belt.>	Go to step 3.

Diagnostic Chart with Trouble Code

AIRBAG SYSTEM (DIAGNOSTICS)

Brought to you by Eris Studios
NOT FOR RESALE

Step	Check	Yes	No
3 CHECK AIRBAG REAR HARNESS (PRE-TENSIONER HARNESS RH). 1) Turn the ignition switch to OFF, disconnect the battery ground cable, and wait for 20 seconds or more. 2) Disconnect the airbag resistor from test harness. 3) Disconnect connector (AB24) from side airbag module (RH). 4) Disconnect the connector (AB33) from curtain airbag module (RH). 5) Disconnect the connectors (AB6, AB17, and AB18) from airbag control module. 6) Connect the connector (1AG) in the test harness AG to the connectors (AB6, AB17, and AB18). 7) Measure the resistance between connector (3AG) in the test harness AG and connector (2N) in the test harness N. <i>Connector & terminal</i> <i>(3AG) No. 18 — (2N) No. 2:</i> <i>(3AG) No. 20 — (2N) No. 1:</i>	Is the resistance less than 10 Ω?	Go to step 4.	Replace the airbag rear harness along with body harness.
4 CHECK AIRBAG REAR HARNESS (PRE-TENSIONER HARNESS RH). Measure the resistance between connector (3AG) terminals in the test harness AG. <i>Connector & terminal</i> <i>(3AG) No. 18 — (3AG) No. 20:</i>	Is the resistance 1 MΩ or more?	Go to step 5.	Replace the airbag rear harness along with body harness.
5 CHECK AIRBAG REAR HARNESS (PRE-TENSIONER HARNESS RH). Measure the resistance between connector (3AG) in the test harness AG and chassis ground. <i>Connector & terminal</i> <i>(3AG) No. 18 — Chassis ground:</i> <i>(3AG) No. 20 — Chassis ground:</i>	Is the resistance 1 MΩ or more?	Go to step 6.	Replace the airbag rear harness along with body harness.
6 CHECK AIRBAG CONTROL MODULE. 1) Connect all connectors. 2) Erase the memory. 3) Perform the Inspection Mode. 4) Read the DTC.	Is the same DTC displayed?	Replace the airbag control module. <Ref. to AB-22, Airbag Control Module.>	Go to step 7.
7 CHECK FOR ANY OTHER DTC ON DISPLAY.	Is any other DTC displayed?	Check DTC using "List of Diagnostic Trouble Code (DTC)". <Ref. to AB(diag)-42, List of Diagnostic Trouble Code (DTC).>	Finish the diagnosis.

Diagnostic Chart with Trouble Code

AIRBAG SYSTEM (DIAGNOSTICS)

Brought to you by Eriss Studios
NOT FOR SALE

AA:DTC 62 BELT PRETENSIONER LH FAILURE

DTC DETECTING CONDITION:

- Seat belt pretensioner (LH) circuit is open, shorted or shorted to ground.
- Airbag control module is faulty.
- Pretensioner is faulty.
- Pretensioner harness is faulty.

CAUTION:

- Before diagnosing the airbag system, be sure to turn the ignition switch to OFF, disconnect the ground terminal from battery, and wait 20 seconds or more before starting to work.
- When replacing the airbag module, seat belt pretensioner, roll connector, control module and sensor, reconnect each part and check that the warning light operates properly.
- When inspecting the airbag main harness, disconnect the airbag module connectors of the driver's and passenger's seats for safety.
- When inspecting the airbag rear harness, disconnect the side airbag module connector, curtain airbag module connector and seat belt pretensioner connector for safety reasons.

WIRING DIAGRAM:

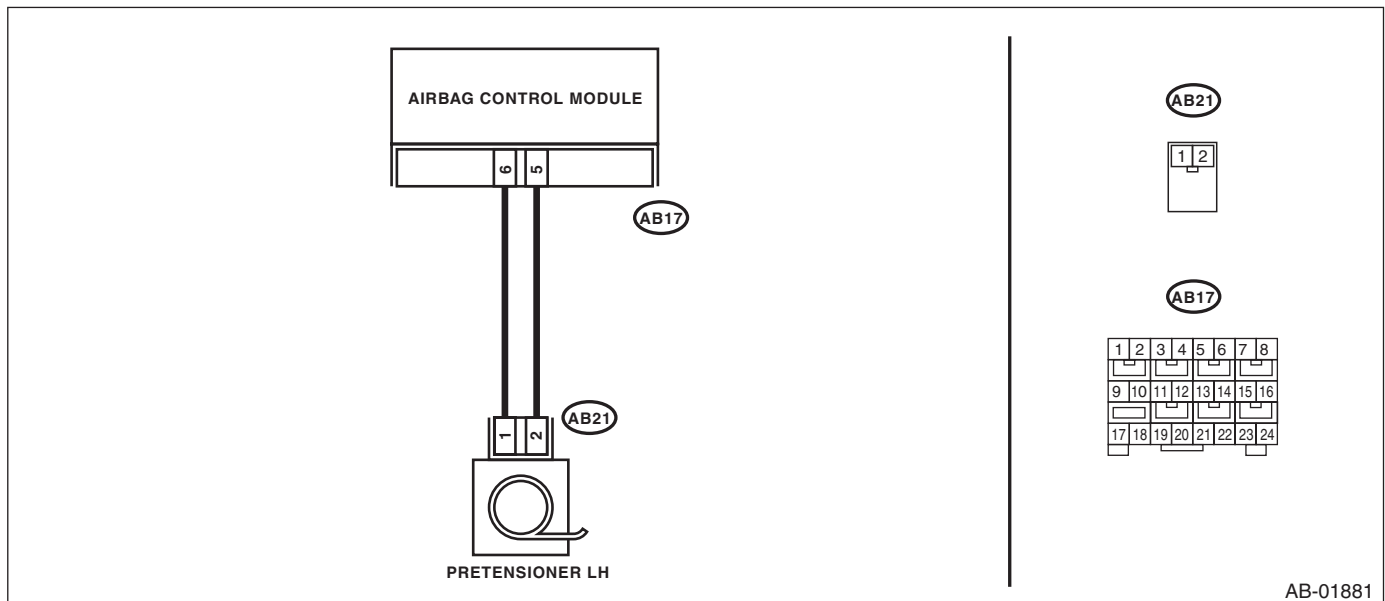

Step	Check	Yes	No
1 CHECK POOR CONTACT IN CONNECTORS. Check for poor contact of the connectors between the airbag control module and the seat belt pretensioner LH.	Is there poor contact?	Replace the airbag rear harness along with body harness.	Go to step 2.
2 CHECK SEAT BELT PRETENSIONER. 1) Turn the ignition switch to OFF, disconnect the battery ground cable, and wait for 20 seconds or more. 2) Disconnect the connector (AB21) from seat belt pretensioner (LH). 3) Connect the connector (1N) in the test harness N to the connector (AB21). 4) Connect the airbag resistor to the connector (2N) of test harness N. 5) Connect the battery ground terminal and turn the ignition switch to ON.	Does the airbag warning light illuminate for 6 seconds and go off?	Replace the seat belt pretensioner (LH). <Ref. to SB-17, Front Seat Belt.>	Go to step 3.

Diagnostic Chart with Trouble Code

AIRBAG SYSTEM (DIAGNOSTICS)

Brought to you by Eris Studios
NOT FOR RESALE

Step	Check	Yes	No
3 CHECK AIRBAG REAR HARNESS (PRE-TENSIONER HARNESS LH). 1) Turn the ignition switch to OFF, disconnect the battery ground cable, and wait for 20 seconds or more. 2) Disconnect the airbag resistor from test harness. 3) Disconnect connector (AB19) from side airbag module (LH). 4) Disconnect the connector (AB31) from curtain airbag module (LH). 5) Disconnect the connectors (AB6, AB17, and AB18) from airbag control module. 6) Connect the connector (1AG) in the test harness AG to the connectors (AB6, AB17, and AB18). 7) Measure the resistance between connector (3AG) in the test harness AG and connector (2N) in the test harness N. <i>Connector & terminal</i> <i>(3AG) No. 12 — (2N) No. 2:</i> <i>(3AG) No. 10 — (2N) No. 1:</i>	Is the resistance less than 10 Ω?	Go to step 4.	Replace the airbag rear harness along with body harness.
4 CHECK AIRBAG REAR HARNESS (PRE-TENSIONER HARNESS LH). Measure the resistance between connector (3AG) terminals in the test harness AG. <i>Connector & terminal</i> <i>(3AG) No. 10 — (3AG) No. 12:</i>	Is the resistance 1 MΩ or more?	Go to step 5.	Replace the airbag rear harness along with body harness.
5 CHECK AIRBAG REAR HARNESS (PRE-TENSIONER HARNESS LH). Measure the resistance between connector (3AG) in the test harness AG and chassis ground. <i>Connector & terminal</i> <i>(3AG) No. 10 — Chassis ground:</i> <i>(3AG) No. 12 — Chassis ground:</i>	Is the resistance 1 MΩ or more?	Go to step 6.	Replace the airbag rear harness along with body harness.
6 CHECK AIRBAG CONTROL MODULE. 1) Connect all connectors. 2) Erase the memory. 3) Perform the Inspection Mode. 4) Read the DTC.	Is the same DTC displayed?	Replace the airbag control module. <Ref. to AB-22, Airbag Control Module.>	Go to step 7.
7 CHECK FOR ANY OTHER DTC ON DISPLAY.	Is any other DTC displayed?	Check DTC using "List of Diagnostic Trouble Code (DTC)". <Ref. to AB(diag)-42, List of Diagnostic Trouble Code (DTC).>	Finish the diagnosis.

Diagnostic Chart with Trouble Code

AIRBAG SYSTEM (DIAGNOSTICS)

Brought to you by Eris Studios
NOT FOR SALE

AB:DTC 65 BELT PRETENSIONER RH FAILURE

DTC DETECTING CONDITION:

- Seat belt pretensioner (RH) circuit is shorted to power supply.
- Pretensioner is faulty.
- Pretensioner harness is faulty.
- Airbag control module is faulty.

CAUTION:

- Before diagnosing the airbag system, be sure to turn the ignition switch to OFF, disconnect the ground terminal from battery, and wait 20 seconds or more before starting to work.
- When replacing the airbag module, seat belt pretensioner, roll connector, control module and sensor, reconnect each part and check that the warning light operates properly.
- When inspecting the airbag main harness, disconnect the airbag module connectors of the driver's and passenger's seats for safety.
- When inspecting the airbag rear harness, disconnect the side airbag module connector, curtain airbag module connector and seat belt pretensioner connector for safety reasons.

WIRING DIAGRAM:

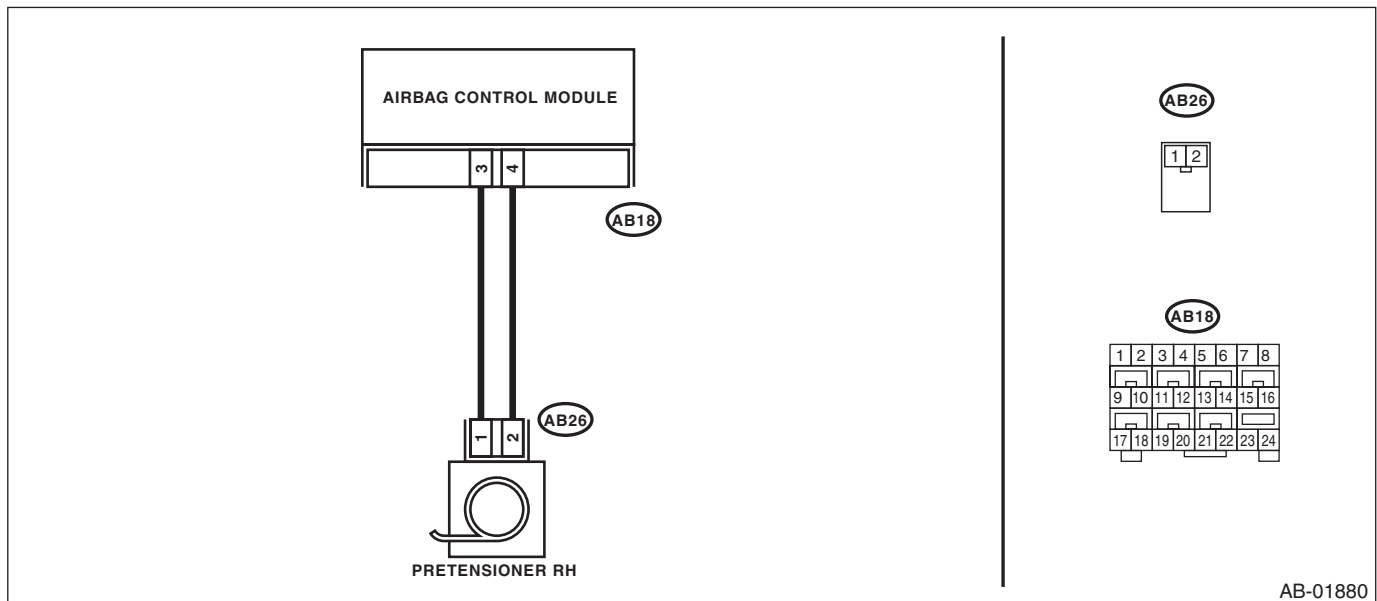

Diagnostic Chart with Trouble Code

AIRBAG SYSTEM (DIAGNOSTICS)

Brought to you by Eris Studios
NOT FOR RESALE

Step	Check	Yes	No
1 CHECK POOR CONTACT IN CONNECTORS. Check for poor contact of the connectors between the airbag control module and the seat belt pretensioner RH.	Is there poor contact?	Replace the airbag rear harness along with body harness.	Go to step 2.
2 CHECK SEAT BELT PRETENSIONER. 1) Turn the ignition switch to OFF, disconnect the battery ground cable, and wait for 20 seconds or more. 2) Disconnect the connector (AB26) from seat belt pretensioner (RH). 3) Connect the connector (1N) in the test harness N to the connector (AB26). 4) Connect the airbag resistor to the connector (2N) of test harness N. 5) Connect the battery ground terminal and turn the ignition switch to ON.	Does the airbag warning light illuminate for 6 seconds and go off?	Replace the seat belt pretensioner (RH). <Ref. to SB-17, Front Seat Belt.>	Go to step 3.
3 CHECK AIRBAG REAR HARNESS (PRETENSIONER HARNESS RH). 1) Turn the ignition switch to OFF, disconnect the battery ground cable, and wait for 20 seconds or more. 2) Disconnect the airbag resistor from test harness. 3) Disconnect connector (AB24) from side airbag module (RH). 4) Disconnect the connector (AB33) from curtain airbag module (RH). 5) Disconnect the connectors (AB6, AB17, and AB18) from airbag control module. 6) Connect the connector (1AG) in the test harness AG to the connectors (AB6, AB17, and AB18). 7) Connect the battery ground terminal and turn the ignition switch to ON. 8) Measure the voltage between connector (3AG) in the test harness AG and chassis ground. Connector & terminal (3AG) No. 20 (+) — Chassis ground (-): (3AG) No. 18 (+) — Chassis ground (-):	Is the voltage less than 1 V?	Go to step 4.	Replace the airbag rear harness along with body harness.
4 CHECK AIRBAG CONTROL MODULE. 1) Connect all connectors. 2) Erase the memory. 3) Perform the Inspection Mode. 4) Read the DTC.	Is the same DTC displayed?	Replace the airbag control module. <Ref. to AB-22, Airbag Control Module.>	Go to step 5.
5 CHECK FOR ANY OTHER DTC ON DISPLAY.	Is any other DTC displayed?	Check DTC using "List of Diagnostic Trouble Code (DTC)". <Ref. to AB(diag)-42, List of Diagnostic Trouble Code (DTC).>	Finish the diagnosis.

Diagnostic Chart with Trouble Code

AIRBAG SYSTEM (DIAGNOSTICS)

Brought to you by Eris Studios
NOT FOR SALE

AC:DTC 66 BELT PRETENSIONER LH FAILURE

DTC DETECTING CONDITION:

- Seat belt pretensioner (LH) circuit is shorted to power supply.
- Pretensioner is faulty.
- Pretensioner harness is faulty.
- Airbag control module is faulty.

CAUTION:

- Before diagnosing the airbag system, be sure to turn the ignition switch to OFF, disconnect the ground terminal from battery, and wait 20 seconds or more before starting to work.
- When replacing the airbag module, seat belt pretensioner, roll connector, control module and sensor, reconnect each part and check that the warning light operates properly.
- When inspecting the airbag main harness, disconnect the airbag module connectors of the driver's and passenger's seats for safety.
- When inspecting the airbag rear harness, disconnect the side airbag module connector, curtain airbag module connector and seat belt pretensioner connector for safety reasons.

WIRING DIAGRAM:

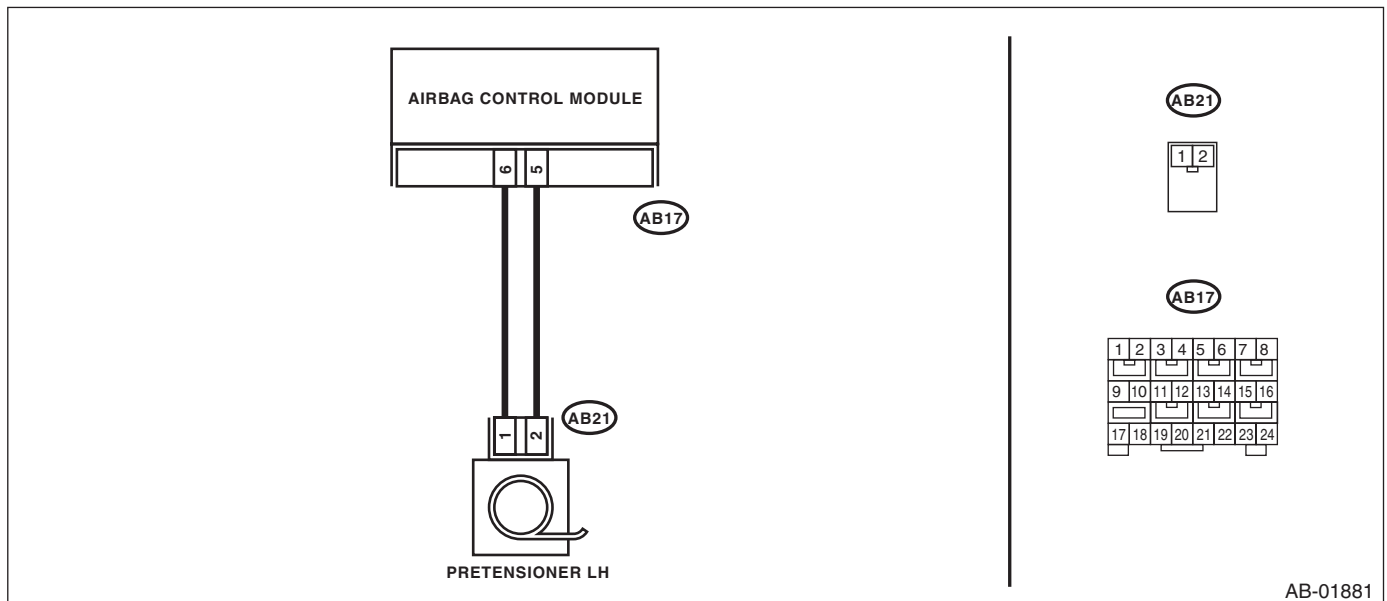

Diagnostic Chart with Trouble Code

AIRBAG SYSTEM (DIAGNOSTICS)

Brought to you by Eris Studios
NOT FOR RESALE

Step	Check	Yes	No
1 CHECK POOR CONTACT IN CONNECTORS. Check for poor contact of the connectors between the airbag control module and the seat belt pretensioner LH.	Is there poor contact?	Replace the airbag rear harness along with body harness.	Go to step 2.
2 CHECK SEAT BELT PRETENSIONER. 1) Turn the ignition switch to OFF, disconnect the battery ground cable, and wait for 20 seconds or more. 2) Disconnect the connector (AB21) from seat belt pretensioner (LH). 3) Connect the connector (1N) in the test harness N to the connector (AB21). 4) Connect the airbag resistor to the connector (2N) of test harness N. 5) Connect the battery ground terminal and turn the ignition switch to ON.	Does the airbag warning light illuminate for 6 seconds and go off?	Replace the seat belt pretensioner (LH). <Ref. to SB-17, Front Seat Belt.>	Go to step 3.
3 CHECK AIRBAG REAR HARNESS (PRE-TENSIONER HARNESS LH). 1) Turn the ignition switch to OFF, disconnect the battery ground cable, and wait for 20 seconds or more. 2) Disconnect the airbag resistor from test harness. 3) Disconnect connector (AB19) from side airbag module (LH). 4) Disconnect the connector (AB31) from curtain airbag module (LH). 5) Disconnect the connectors (AB6, AB17, and AB18) from airbag control module. 6) Connect the connector (1AG) in the test harness AG to the connectors (AB6, AB17, and AB18). 7) Connect the battery ground terminal and turn the ignition switch to ON. 8) Measure the voltage between connector (3AG) in the test harness AG and chassis ground. Connector & terminal (3AG) No. 10 (+) — Chassis ground (-): (3AG) No. 12 (+) — Chassis ground (-):	Is the voltage less than 1 V?	Go to step 4.	Replace the airbag rear harness along with body harness.
4 CHECK AIRBAG CONTROL MODULE. 1) Connect all connectors. 2) Erase the memory. 3) Perform the Inspection Mode. 4) Read the DTC.	Is the same DTC displayed?	Replace the airbag control module. <Ref. to AB-22, Airbag Control Module.>	Go to step 5.
5 CHECK FOR ANY OTHER DTC ON DISPLAY.	Is any other DTC displayed?	Check DTC using "List of Diagnostic Trouble Code (DTC)". <Ref. to AB(diag)-42, List of Diagnostic Trouble Code (DTC).>	Finish the diagnosis.

Diagnostic Chart with Trouble Code

Brought to you by Eris Studios
 NOT FOR SALE

AD:DTC 71 DRIVER'S AIRBAG FAILURE

DTC DETECTING CONDITION:

- Airbag main harness circuit is open, shorted or shorted to ground.
- Airbag module harness (driver's side) circuit is open, shorted or shorted to ground.
- Roll connector circuit is open, shorted or shorted to ground.
- Driver's airbag module is faulty.
- Airbag control module is faulty.

CAUTION:

- Before diagnosing the airbag system, be sure to turn the ignition switch to OFF, disconnect the ground cable from the battery, and wait 20 seconds or more before starting to work.
- When replacing the airbag module, seat belt pretensioner, roll connector, control module and sensor, reconnect each part and check that the warning light operates properly.
- When inspecting the airbag main harness, disconnect the airbag module connectors of the driver's and passenger's seats for safety.
- When inspecting the airbag rear harness, disconnect the side airbag module connector, curtain airbag module connector and seat belt pretensioner connector for safety reasons.

NOTE:

Prior to starting work, prepare two airbag resistors (98299PA040).

WIRING DIAGRAM:

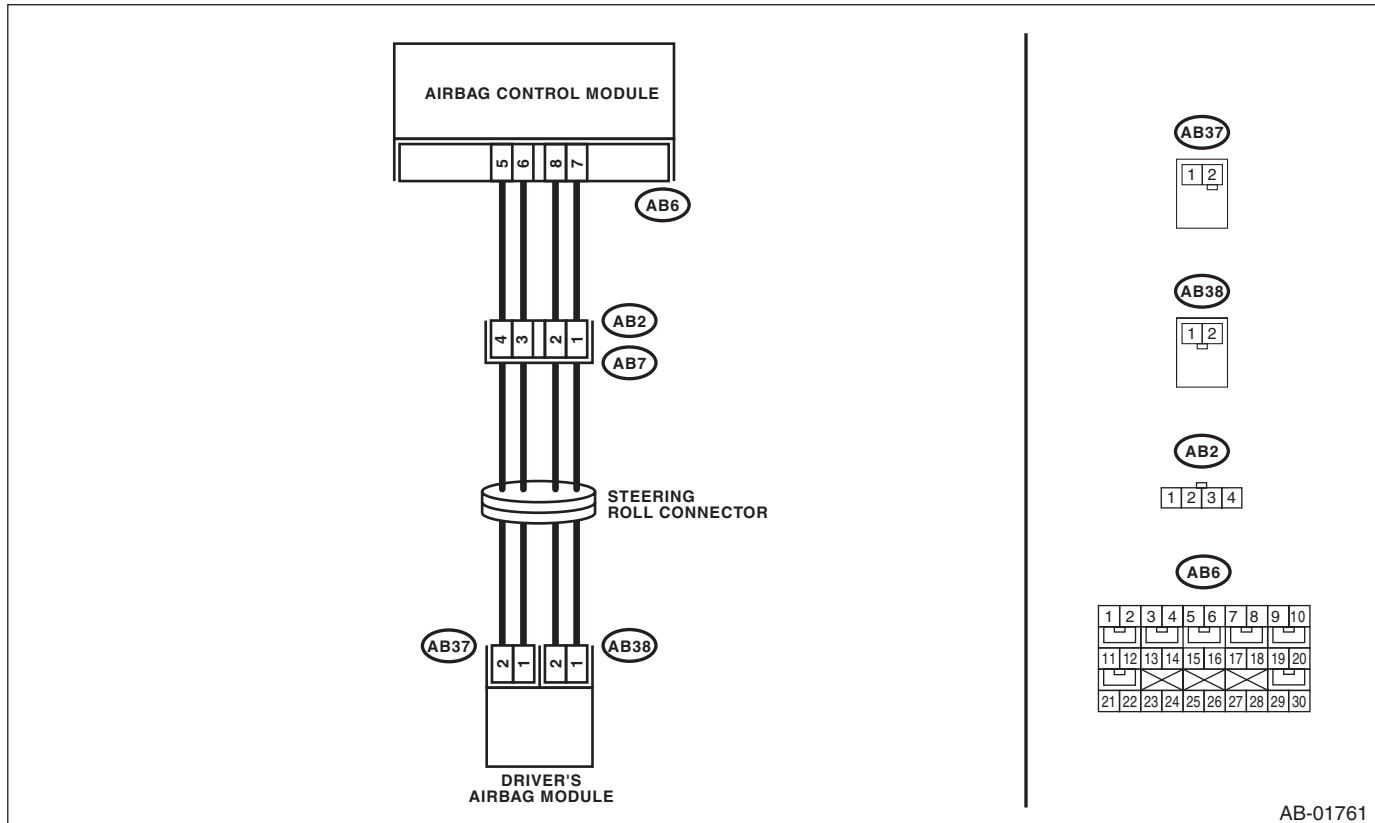

AB-01761

Diagnostic Chart with Trouble Code

AIRBAG SYSTEM (DIAGNOSTICS)

Brought to you by Eris Studios
NOT FOR RESALE

Step	Check	Yes	No
1 CHECK POOR CONTACT IN CONNECTORS. Check for poor contact of the connectors between the airbag control module and the driver's airbag module.	Is there poor contact?	Replace the airbag main harness along with body harness.	Go to step 2.
2 CHECK DRIVER'S AIRBAG MODULE. 1) Turn the ignition switch to OFF, disconnect the battery ground cable, and wait for 20 seconds or more. 2) Remove the driver's airbag module. 3) Connect the connector (1N) in the test harness N to the connector (AB38). 4) Connect the airbag resistor to the connector (2N) of test harness N. 5) Connect the connector (1Q) in the test harness Q to connector (AB37). 6) Connect the airbag resistor to the connector (2Q) in the test harness Q. 7) Connect the battery ground terminal and turn the ignition switch to ON.	Does the airbag warning light illuminate for 6 seconds and go off?	Replace the driver's airbag module. <Ref. to AB-16, Driver's Airbag Module.>	Go to step 3.
3 CHECK ROLL CONNECTOR. 1) Turn the ignition switch to OFF, disconnect the battery ground cable, and wait for 20 seconds or more. 2) Disconnect the test harness N from connector (AB38). 3) Disconnect the test harness Q from connector (AB37). 4) Remove the instrument panel lower cover and disconnect the connector (AB7) from (AB2). 5) Connect the connector (1P) in the test harness P to connector (AB2). 6) Connect the airbag resistor to the connectors (2P) and (3P) of test harness P. 7) Connect the battery ground terminal and turn the ignition switch to ON.	Does the airbag warning light illuminate for 6 seconds and go off?	Replace the roll connector. <Ref. to AB-27, Roll Connector.>	Go to step 4.
4 CHECK AIRBAG MAIN HARNESS (DRIVER'S AIRBAG HARNESS). 1) Turn the ignition switch to OFF, disconnect the battery ground cable, and wait for 20 seconds or more. 2) Disconnect the airbag resistor from the connectors (2P) and (3P) of test harness P. 3) Remove the instrument panel side cover on the passenger's side and disconnect the connectors (AB10) and (AB9). 4) Disconnect the connectors (AB6, AB17, and AB18) from the airbag control module, and connect the connector (1AG) in the test harness AG. 5) Measure the resistance between connector (3AG) in the test harness AG and connectors (2P) and (3P) in the test harness P. Connector & terminal (3AG) No. 2 — (3P) No. 3: (3AG) No. 4 — (3P) No. 4:	Is the resistance less than 10 Ω?	Go to step 5.	Replace the airbag main harness along with body harness.

Diagnostic Chart with Trouble Code

AIRBAG SYSTEM (DIAGNOSTICS)

Brought to you by Eris Studios
NOT FOR SALE

Step	Check	Yes	No
5 CHECK AIRBAG MAIN HARNESS (DRIVER'S AIRBAG HARNESS). Measure the resistance between connectors (3AG) in the test harness AG, and between connector (3AG) and chassis ground. Connector & terminal (3AG) No. 1 — (3AG) No. 3: (3AG) No. 3 — Chassis ground: (3AG) No. 1 — Chassis ground: (3AG) No. 2 — (3AG) No. 4: (3AG) No. 2 — Chassis ground: (3AG) No. 4 — Chassis ground: (3AG) No. 1 — (3AG) No. 2: (3AG) No. 1 — (3AG) No. 4: (3AG) No. 2 — (3AG) No. 3: (3AG) No. 3 — (3AG) No. 4:	Is the resistance 1 MΩ or more?	Go to step 6.	Replace the airbag main harness along with body harness.
6 CHECK AIRBAG CONTROL MODULE. 1) Connect all connectors. 2) Erase the memory. 3) Perform the Inspection Mode. 4) Read the DTC.	Is the same DTC displayed?	Replace the airbag control module. <Ref. to AB-22, Airbag Control Module.>	Go to step 7.
7 CHECK FOR ANY OTHER DTC ON DISPLAY.	Is any other DTC displayed?	Check DTC using "List of Diagnostic Trouble Code (DTC)". <Ref. to AB(diag)-42, List of Diagnostic Trouble Code (DTC).>	Finish the diagnosis.

Diagnostic Chart with Trouble Code

Brought to you by Eris Studios
NOT FOR RESALE

AIRBAG SYSTEM (DIAGNOSTICS)

AE:DTC 72 PASSENGER'S AIRBAG FAILURE

DTC DETECTING CONDITION:

- Airbag main harness circuit is open, shorted or shorted to ground.
- Airbag module harness (Passenger's side) circuit is open, shorted or shorted to ground.
- Passenger's airbag module is faulty.
- Airbag control module is faulty.

CAUTION:

- Before diagnosing the airbag system, be sure to turn the ignition switch to OFF, disconnect the ground cable from the battery, and wait 20 seconds or more before starting to work.
- When replacing the airbag module, seat belt pretensioner, roll connector, control module and sensor, reconnect each part and check that the warning light operates properly.
- When inspecting the airbag main harness, disconnect the airbag module connectors of the driver's and passenger's seats for safety.
- When inspecting the airbag rear harness, disconnect the side airbag module connector, curtain airbag module connector and seat belt pretensioner connector for safety reasons.

NOTE:

Prior to starting work, prepare two airbag resistors (98299PA040).

WIRING DIAGRAM:

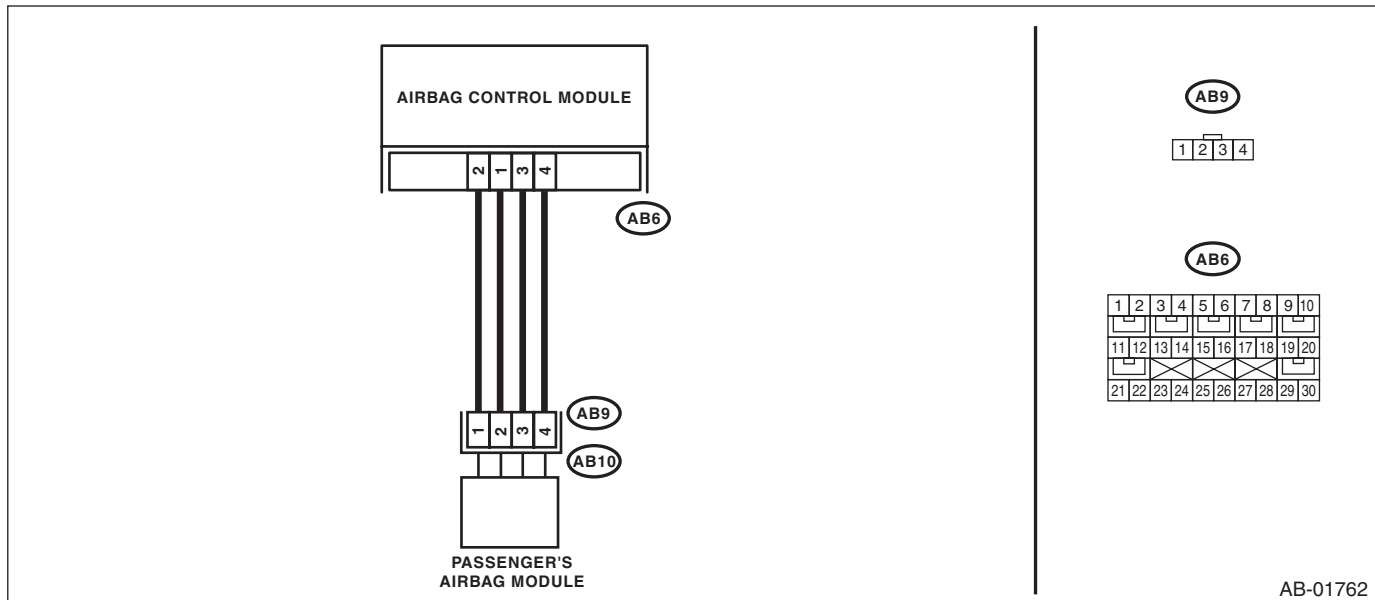

Step	Check	Yes	No
1 CHECK POOR CONTACT IN CONNECTORS. Check for poor contact of the connectors between the airbag control module and the passenger's airbag module.	Is there poor contact?	Replace the airbag main harness along with body harness.	Go to step 2.
2 CHECK PASSENGER'S AIRBAG MODULE. 1) Turn the ignition switch to OFF, disconnect the battery ground cable, and wait for 20 seconds or more. 2) Remove the instrument panel side cover on the passenger's side and disconnect the connector (AB10) from (AB9). 3) Connect the connector (1P) in the test harness P to connector (AB9). 4) Connect the airbag resistor to the connectors (2P) and (3P) of test harness P. 5) Connect the battery ground terminal and turn the ignition switch to ON.	Does the airbag warning light illuminate for 6 seconds and go off?	Replace the passenger's airbag module. <Ref. to AB-17, Passenger's Airbag Module.>	Go to step 3.

Diagnostic Chart with Trouble Code

AIRBAG SYSTEM (DIAGNOSTICS)

Brought to you by Eris Studios
NOT FOR SALE

Step	Check	Yes	No
<p>3 CHECK AIRBAG MAIN HARNESS (PASSENGER'S AIRBAG HARNESS).</p> <p>1) Turn the ignition switch to OFF, disconnect the battery ground cable, and wait for 20 seconds or more.</p> <p>2) Disconnect the airbag resistor from the connectors (2P) and (3P) of test harness P.</p> <p>3) Remove the instrument panel lower cover and disconnect the connector (AB7) from (AB2).</p> <p>4) Disconnect the connectors (AB6, AB17, and AB18) from the airbag control module, and connect the connector (1AG) in the test harness AG.</p> <p>5) Measure the resistance between connector (3AG) in the test harness AG and connectors (2P) and (3P) in the test harness P.</p> <p>Connector & terminal (3AG) No. 8 — (3P) No. 3: (3AG) No. 6 — (3P) No. 4:</p>	Is the resistance less than 10 Ω?	Go to step 4.	Replace the airbag main harness along with body harness.
<p>4 CHECK AIRBAG MAIN HARNESS (PASSENGER'S AIRBAG HARNESS).</p> <p>Measure the resistance between connectors (3AG) in the test harness AG, and between connector (3AG) and chassis ground.</p> <p>Connector & terminal (3AG) No. 9 — (3AG) No. 7: (3AG) No. 9 — Chassis ground: (3AG) No. 7 — Chassis ground: (3AG) No. 8 — (3AG) No. 6: (3AG) No. 8 — Chassis ground: (3AG) No. 6 — Chassis ground: (3AG) No. 6 — (3AG) No. 7: (3AG) No. 6 — (3AG) No. 9: (3AG) No. 7 — (3AG) No. 8: (3AG) No. 8 — (3AG) No. 9:</p>	Is the resistance 1 MΩ or more?	Go to step 5.	Replace the airbag main harness along with body harness.
<p>5 CHECK AIRBAG CONTROL MODULE.</p> <p>1) Connect all connectors.</p> <p>2) Erase the memory.</p> <p>3) Perform the Inspection Mode.</p> <p>4) Read the DTC.</p>	Is the same DTC displayed?	Replace the airbag control module. <Ref. to AB-22, Airbag Control Module.>	Go to step 6.
<p>6 CHECK FOR ANY OTHER DTC ON DISPLAY.</p>	Is any other DTC displayed?	Check DTC using "List of Diagnostic Trouble Code (DTC)". <Ref. to AB(diag)-42, List of Diagnostic Trouble Code (DTC).>	Finish the diagnosis.

Diagnostic Chart with Trouble Code

AIRBAG SYSTEM (DIAGNOSTICS)

Brought to you by Eris Studios
NOT FOR RESALE

AF:DTC 75 DRIVER'S AIRBAG FAILURE

DTC DETECTING CONDITION:

- Airbag main harness circuit (Driver's side) is shorted to power supply.
- Airbag module harness circuit (Driver's side) is shorted to power supply.
- Roll connector is shorted to power supply.
- Driver's airbag module is faulty.
- Airbag control module is faulty.

CAUTION:

- Before diagnosing the airbag system, be sure to turn the ignition switch to OFF, disconnect the ground cable from the battery, and wait 20 seconds or more before starting to work.
- When replacing the airbag module, seat belt pretensioner, roll connector, control module and sensor, reconnect each part and check that the warning light operates properly.
- When inspecting the airbag main harness, disconnect the airbag module connectors of the driver's and passenger's seats for safety.
- When inspecting the airbag rear harness, disconnect the side airbag module connector, curtain airbag module connector and seat belt pretensioner connector for safety reasons.

NOTE:

Prior to starting work, prepare two airbag resistors (98299PA040).

WIRING DIAGRAM:

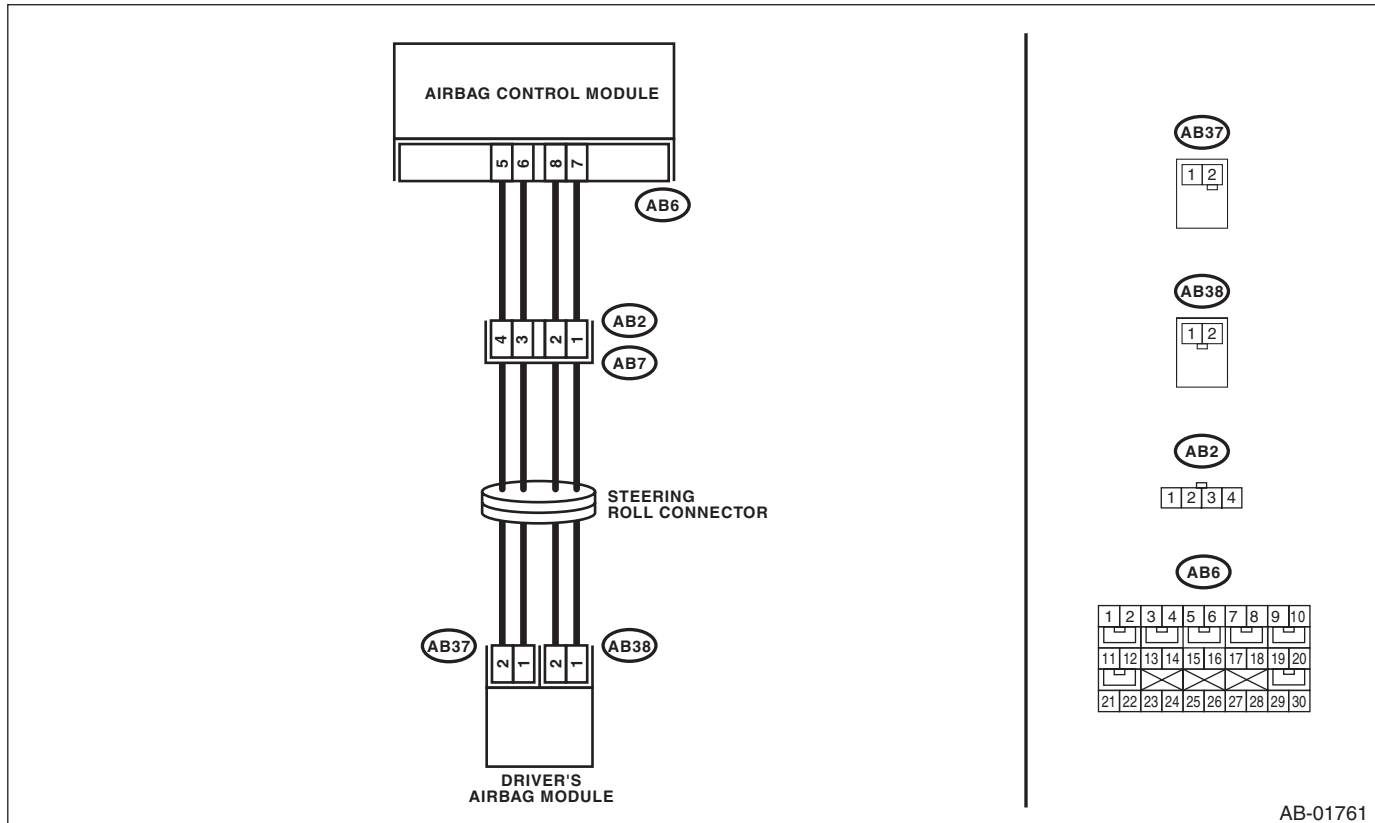

AB-01761

Diagnostic Chart with Trouble Code

AIRBAG SYSTEM (DIAGNOSTICS)

Brought to you by Eris Studios
NOT FOR SALE

Step	Check	Yes	No
1 CHECK POOR CONTACT IN CONNECTORS. Check for poor contact of the connectors between the airbag control module and the driver's airbag module.	Is there poor contact?	Replace the airbag main harness along with body harness.	Go to step 2.
2 CHECK DRIVER'S AIRBAG MODULE. 1) Turn the ignition switch to OFF, disconnect the battery ground cable, and wait for 20 seconds or more. 2) Remove the driver's airbag module. 3) Connect the connector (AB38) to the connector (1N) in the test harness N. 4) Connect the airbag resistor to the connector (2N) of test harness N. 5) Connect the connector (1Q) in the test harness Q to connector (AB37). 6) Connect the airbag resistor to the connector (2Q) in the test harness Q. 7) Connect the battery ground terminal and turn the ignition switch to ON.	Does the airbag warning light illuminate for 6 seconds and go off?	Replace the driver's airbag module. <Ref. to AB-16, Driver's Airbag Module.>	Go to step 3.
3 CHECK ROLL CONNECTOR. 1) Turn the ignition switch to OFF, disconnect the battery ground cable, and wait for 20 seconds or more. 2) Disconnect the test harness N from connector (AB38). 3) Disconnect the test harness Q from connector (AB37). 4) Remove the instrument panel lower cover and disconnect the connector (AB7) from (AB2). 5) Connect the connector (1P) in the test harness P to connector (AB2). 6) Connect the airbag resistor to the connectors (2P) and (3P) of test harness P. 7) Connect the battery ground terminal and turn the ignition switch to ON.	Does the airbag warning light illuminate for 6 seconds and go off?	Replace the roll connector. <Ref. to AB-27, Roll Connector.>	Go to step 4.
4 CHECK AIRBAG MAIN HARNESS (DRIVER'S AIRBAG HARNESS). 1) Turn the ignition switch to OFF, disconnect the battery ground cable, and wait for 20 seconds or more. 2) Disconnect the airbag resistor from the connectors (2P) and (3P) of test harness P. 3) Remove the instrument panel side cover on the passenger's side and disconnect the connectors (AB10) and (AB9). 4) Disconnect the connectors (AB6, AB17, and AB18) from the airbag control module, and connect the connector (1AG) in the test harness AG. 5) Connect the battery ground terminal and turn the ignition switch to ON. (engine OFF) 6) Measure the voltage between connector (3AG) in the test harness AG and chassis ground. Connector & terminal (3AG) No. 2 (+) — Chassis ground (-): (3AG) No. 4 (+) — Chassis ground (-):	Is the voltage less than 1 V?	Go to step 5.	Replace the airbag main harness along with body harness.

Diagnostic Chart with Trouble Code

AIRBAG SYSTEM (DIAGNOSTICS)

Brought to you by Eris Studios
NOT FOR RESALE

Step	Check	Yes	No
5 CHECK AIRBAG CONTROL MODULE. 1) Connect all connectors. 2) Erase the memory. 3) Perform the Inspection Mode. 4) Read the DTC.	Is the same DTC displayed?	Replace the airbag control module. <Ref. to AB-22, Airbag Control Module.>	Go to step 6 .
6 CHECK FOR ANY OTHER DTC ON DISPLAY.	Is any other DTC displayed?	Check DTC using "List of Diagnostic Trouble Code (DTC)". <Ref. to AB(diag)-42, List of Diagnostic Trouble Code (DTC).>	Finish the diagnosis.

Diagnostic Chart with Trouble Code

AIRBAG SYSTEM (DIAGNOSTICS)

Brought to you by Eris Studios
NOT FOR SALE

AG:DTC 76 PASSENGER'S AIRBAG FAILURE

DTC DETECTING CONDITION:

- Airbag main harness circuit (Passenger's side) is shorted to power supply.
- Airbag module harness circuit (Passenger's side) is shorted to power supply.
- Passenger's airbag module is faulty.
- Airbag control module is faulty.

CAUTION:

- Before diagnosing the airbag system, be sure to turn the ignition switch to OFF, disconnect the ground cable from the battery, and wait 20 seconds or more before starting to work.
- When replacing the airbag module, seat belt pretensioner, roll connector, control module and sensor, reconnect each part and check that the warning light operates properly.
- When inspecting the airbag main harness, disconnect the airbag module connectors of the driver's and passenger's seats for safety.
- When inspecting the airbag rear harness, disconnect the side airbag module connector, curtain airbag module connector and seat belt pretensioner connector for safety reasons.

NOTE:

Prior to starting work, prepare two airbag resistors (98299PA040).

WIRING DIAGRAM:

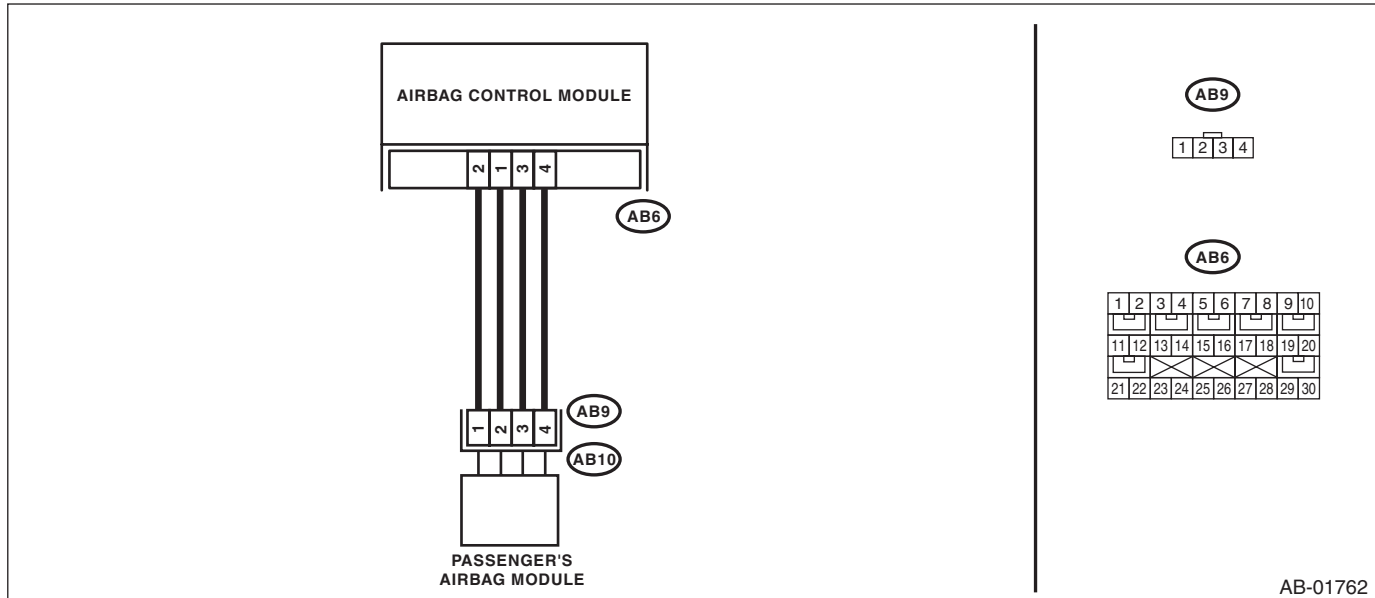

Diagnostic Chart with Trouble Code

AIRBAG SYSTEM (DIAGNOSTICS)

Brought to you by Eris Studios
NOT FOR RESALE

	Step	Check	Yes	No
1	CHECK POOR CONTACT IN CONNECTORS. Check for poor contact of the connectors between the airbag control module and the passenger's airbag module.	Is there poor contact?	Replace the airbag main harness along with body harness.	Go to step 2.
2	CHECK PASSENGER'S AIRBAG MODULE. 1) Turn the ignition switch to OFF, disconnect the battery ground cable, and wait for 20 seconds or more. 2) Remove the instrument panel side cover on the passenger's side and disconnect the connector (AB10) from (AB9). 3) Connect the connector (1P) in the test harness P to connector (AB9). 4) Connect the airbag resistor to the connectors (2P) and (3P) of test harness P. 5) Connect the battery ground terminal and turn the ignition switch to ON.	Does the airbag warning light illuminate for 6 seconds and go off?	Replace the passenger's airbag module. <Ref. to AB-17, Passenger's Airbag Module.>	Go to step 3.
3	CHECK AIRBAG MAIN HARNESS (PASSENGER'S AIRBAG HARNESS). 1) Turn the ignition switch to OFF, disconnect the battery ground cable, and wait for 20 seconds or more. 2) Disconnect the airbag resistor from the connectors (2P) and (3P) of test harness P. 3) Remove the instrument panel lower cover and disconnect the connector (AB7) from (AB2). 4) Disconnect the connectors (AB6, AB17, and AB18) from the airbag control module, and connect the connector (1AG) in the test harness AG. 5) Measure the voltage between connector (3AG) in the test harness AG and chassis ground. Connector & terminal (3AG) No. 8 (+) — Chassis ground (-): (3AG) No. 6 (+) — Chassis ground (-):	Is the voltage less than 1 V?	Go to step 4.	Replace the airbag main harness along with body harness.
4	CHECK AIRBAG CONTROL MODULE. 1) Connect all connectors. 2) Erase the memory. 3) Perform the Inspection Mode. 4) Read the DTC.	Is the same DTC displayed?	Replace the airbag control module. <Ref. to AB-22, Airbag Control Module.>	Go to step 5.
5	CHECK FOR ANY OTHER DTC ON DISPLAY.	Is any other DTC displayed?	Check DTC using "List of Diagnostic Trouble Code (DTC)". <Ref. to AB(diag)-42, List of Diagnostic Trouble Code (DTC).>	Finish the diagnosis.

Diagnostic Chart with Trouble Code

AIRBAG SYSTEM (DIAGNOSTICS)

Brought to you by Eris Studios
NOT FOR SALE

AH:DTC 91 CURTAIN AIRBAG MODULE RH FAILURE

DTC DETECTING CONDITION:

- Curtain airbag harness (RH) is faulty.
- Curtain airbag module (RH) is faulty.
- Airbag control module is faulty.

CAUTION:

- Before diagnosing the airbag system, be sure to turn the ignition switch to OFF, disconnect the ground terminal from battery, and wait 20 seconds or more before starting to work.
- When replacing the airbag module, seat belt pretensioner, roll connector, control module and sensor, reconnect each part and check that the warning light operates properly.
- When inspecting the airbag main harness, disconnect the airbag module connectors of the driver's and passenger's seats for safety.
- When inspecting the airbag rear harness, disconnect the side airbag module connector, curtain airbag module connector and seat belt pretensioner connector for safety reasons.

WIRING DIAGRAM:

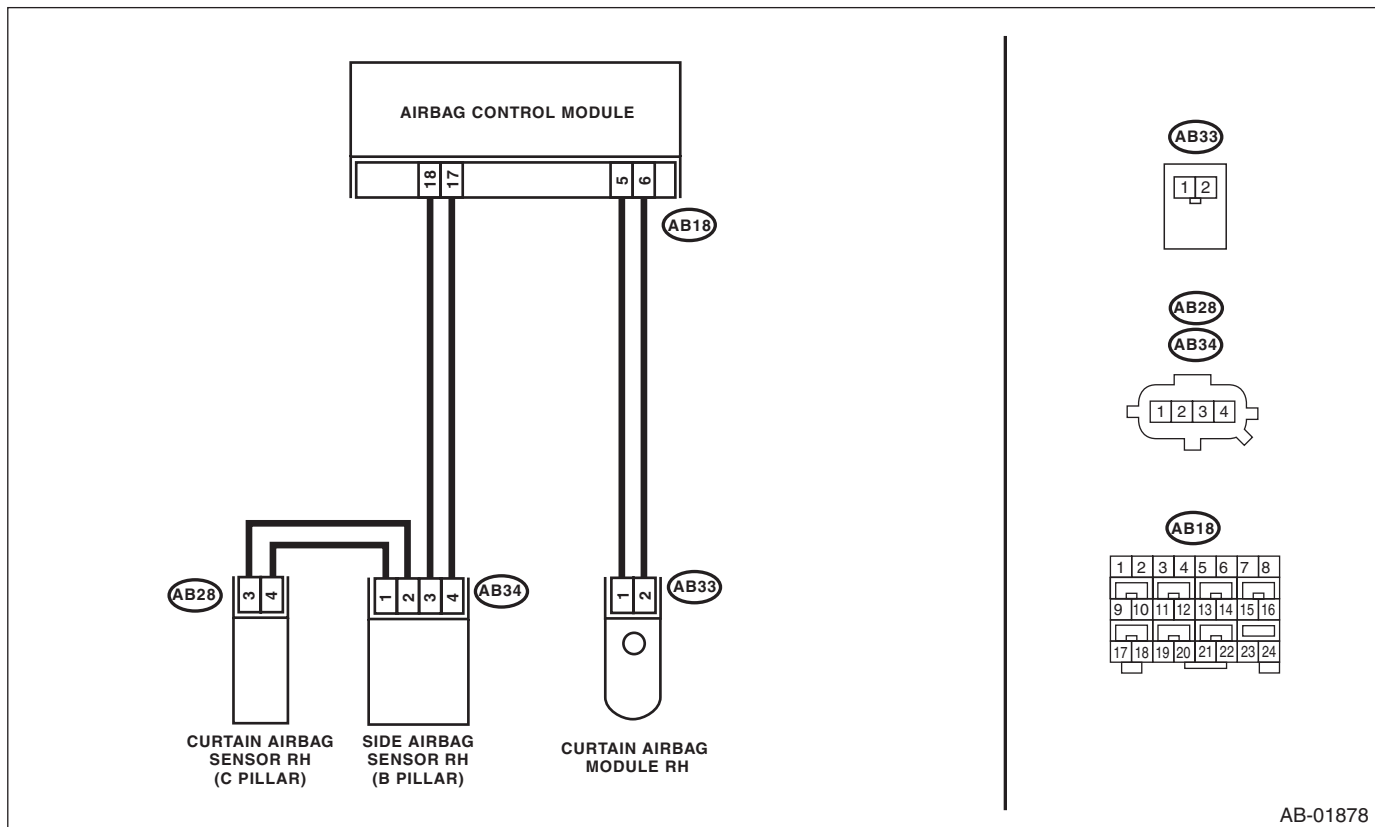

AB-01878

Step	Check	Yes	No	
1	CHECK POOR CONTACT IN CONNECTORS. Check for poor contact of the connectors between the airbag control module, curtain airbag module RH and the curtain airbag sensor RH.	Is there poor contact?	Replace the airbag rear harness along with body harness.	Go to step 2.

Diagnostic Chart with Trouble Code

AIRBAG SYSTEM (DIAGNOSTICS)

Brought to you by Eris Studios
NOT FOR RESALE

Step	Check	Yes	No
2 CHECK CURTAIN AIRBAG MODULE. 1) Turn the ignition switch to OFF, disconnect the battery ground cable, and wait for 20 seconds or more. 2) Disconnect the connector (AB33), and connect the connector (1N) in test harness N to connector (AB33). 3) Connect the airbag resistor to the connector (2N) of test harness N. 4) Connect the battery ground terminal and turn the ignition switch to ON.	Does the airbag warning light illuminate for 6 seconds and go off?	Replace the curtain airbag module (RH). <Ref. to AB-20, Curtain Airbag Module.>	Go to step 3.
3 CHECK AIRBAG REAR HARNESS (CURTAIN AIRBAG MODULE HARNESS RH). 1) Turn the ignition switch to OFF, disconnect the battery ground cable, and wait for 20 seconds or more. 2) Disconnect the connector (AB26) from seat belt pretensioner (RH). 3) Disconnect connector (AB24) from side airbag module (RH). 4) Disconnect the airbag resistor from test harness F. 5) Disconnect the connectors (AB6, AB17, and AB18) from airbag control module. 6) Connect the connector (1AG) in the test harness AG to the connectors (AB6, AB17, and AB18). 7) Measure the resistance between connector (6AG) in the test harness AG and connector (2N) in the test harness N. <i>Connector & terminal</i> <i>(6AG) No. 6 — (2N) No. 1:</i> <i>(6AG) No. 8 — (2N) No. 2:</i>	Is the resistance less than 10 Ω?	Go to step 4.	Replace the airbag rear harness along with body harness.
4 CHECK AIRBAG REAR HARNESS (CURTAIN AIRBAG MODULE HARNESS RH). Measure the resistance between connector (6AG) terminals in the test harness AG. <i>Connector & terminal</i> <i>(6AG) No. 6 — (6AG) No. 8:</i>	Is the resistance 1 MΩ or more?	Go to step 5.	Replace the airbag rear harness along with body harness.
5 CHECK AIRBAG REAR HARNESS (CURTAIN AIRBAG MODULE HARNESS RH). Measure the resistance between connector (6AG) in the test harness AG and chassis ground. <i>Connector & terminal</i> <i>(6AG) No. 6 — Chassis ground:</i> <i>(6AG) No. 8 — Chassis ground:</i>	Is the resistance 1 MΩ or more?	Go to step 6.	Replace the airbag rear harness along with body harness.
6 CHECK AIRBAG CONTROL MODULE. 1) Connect all connectors. 2) Erase the memory. 3) Perform the Inspection Mode. 4) Read the DTC.	Is the same DTC displayed?	Replace the airbag control module. <Ref. to AB-22, Airbag Control Module.>	Go to step 7.
7 CHECK FOR ANY OTHER DTC ON DISPLAY.	Is any other DTC displayed?	Check DTC using "List of Diagnostic Trouble Code (DTC)". <Ref. to AB(diag)-42, List of Diagnostic Trouble Code (DTC).>	Finish the diagnosis.

Diagnostic Chart with Trouble Code

AIRBAG SYSTEM (DIAGNOSTICS)

Brought to you by Eris Studios
NOT FOR SALE

AI: DTC 92 CURTAIN AIRBAG MODULE LH FAILURE

DTC DETECTING CONDITION:

- Curtain airbag harness (LH) is faulty.
- Curtain airbag module (LH) is faulty.
- Airbag control module is faulty.

CAUTION:

- Before diagnosing the airbag system, be sure to turn the ignition switch to OFF, disconnect the ground terminal from battery, and wait 20 seconds or more before starting to work.
- When replacing the airbag module, seat belt pretensioner, roll connector, control module and sensor, reconnect each part and check that the warning light operates properly.
- When inspecting the airbag main harness, disconnect the airbag module connectors of the driver's and passenger's seats for safety.
- When inspecting the airbag rear harness, disconnect the side airbag module connector, curtain airbag module connector and seat belt pretensioner connector for safety reasons.

WIRING DIAGRAM:

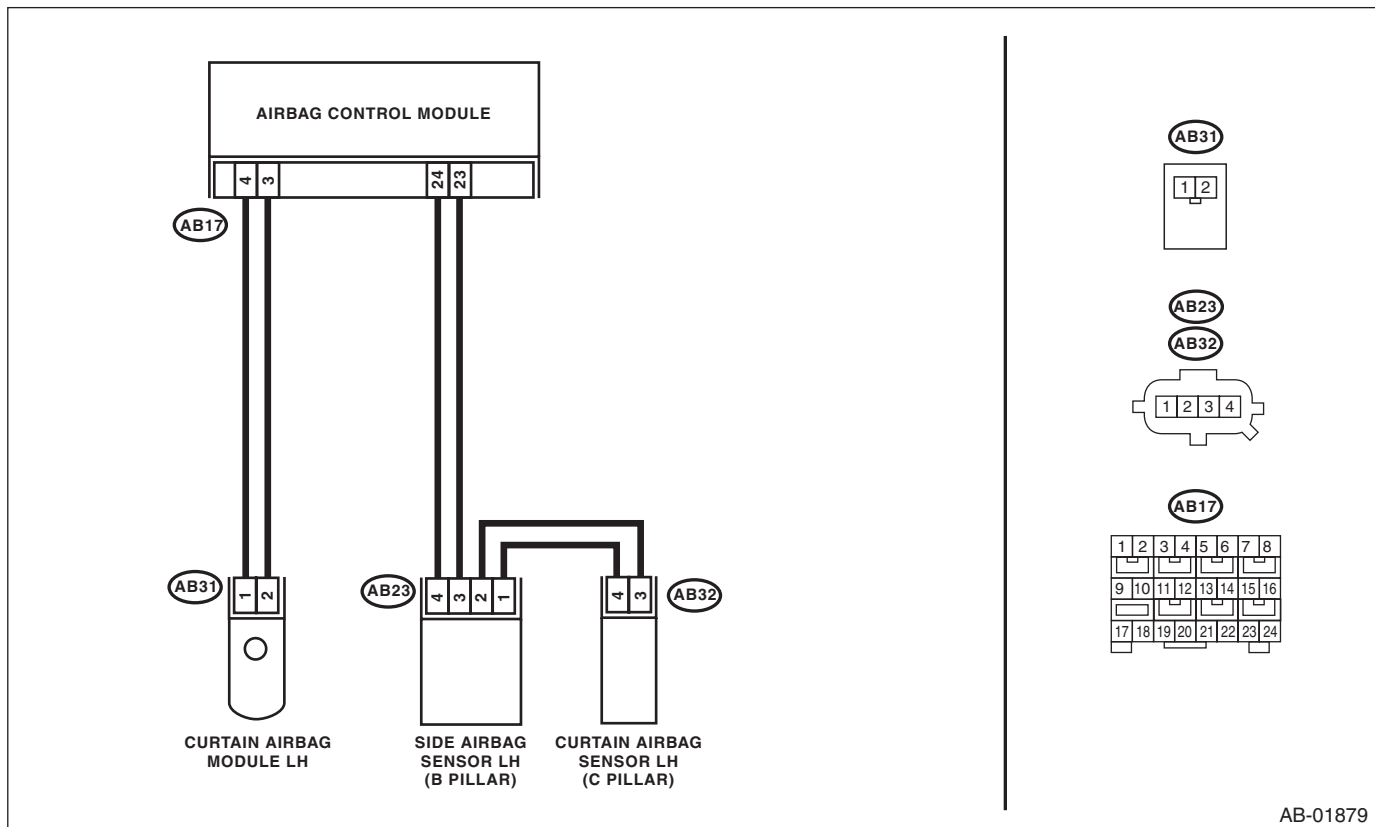

AB-01879

Step	Check	Yes	No
1	CHECK POOR CONTACT IN CONNECTORS. Check for poor contact of the connectors between the airbag control module, curtain airbag module LH and the curtain airbag sensor LH.	Is there poor contact? Replace the airbag rear harness along with body harness.	Go to step 2.

Diagnostic Chart with Trouble Code

AIRBAG SYSTEM (DIAGNOSTICS)

Brought to you by Eris Studios
NOT FOR RESALE

Step	Check	Yes	No
2 CHECK CURTAIN AIRBAG MODULE. 1) Turn the ignition switch to OFF, disconnect the battery ground cable, and wait for 20 seconds or more. 2) Disconnect the connectors (AB31) and (AB39), and connect the connector (1N) in test harness F to connector (AB31). 3) Connect the airbag resistor to the connector (2N) of test harness N. 4) Connect the battery ground terminal and turn the ignition switch to ON.	Does the airbag warning light illuminate for 6 seconds and go off?	Replace the curtain airbag module (LH). <Ref. to AB-20, Curtain Airbag Module.>	Go to step 3.
3 CHECK AIRBAG REAR HARNESS (CURTAIN AIRBAG MODULE HARNESS LH). 1) Turn the ignition switch to OFF, disconnect the battery ground cable, and wait for 20 seconds or more. 2) Disconnect the connector (AB21) from seat belt pretensioner (LH). 3) Disconnect connector (AB19) from side airbag module (LH). 4) Disconnect the airbag resistor from test harness N. 5) Disconnect the connectors (AB6, AB17, and AB18) from airbag control module. 6) Connect the connector (1AG) in the test harness AG to the connectors (AB6, AB17, and AB18). 7) Measure the resistance between connector (6AG) in the test harness AG and connector (2N) in the test harness N. <i>Connector & terminal</i> <i>(6AG) No. 1 — (2N) No. 2:</i> <i>(6AG) No. 3 — (2N) No. 1:</i>	Is the resistance less than 10 Ω?	Go to step 4.	Replace the airbag rear harness along with body harness.
4 CHECK AIRBAG REAR HARNESS (CURTAIN AIRBAG MODULE HARNESS LH). Measure the resistance between connector (6AG) terminals in the test harness AG. <i>Connector & terminal</i> <i>(6AG) No. 1 — (6AG) No. 3:</i>	Is the resistance 1 MΩ or more?	Go to step 5.	Replace the airbag rear harness along with body harness.
5 CHECK AIRBAG REAR HARNESS (CURTAIN AIRBAG MODULE HARNESS LH). Measure the resistance between connector (6AG) in the test harness AG and chassis ground. <i>Connector & terminal</i> <i>(6AG) No. 1 — Chassis ground:</i> <i>(6AG) No. 3 — Chassis ground:</i>	Is the resistance 1 MΩ or more?	Go to step 6.	Replace the airbag rear harness along with body harness.
6 CHECK AIRBAG CONTROL MODULE. 1) Connect all connectors. 2) Erase the memory. 3) Perform the Inspection Mode. 4) Read the DTC.	Is the same DTC displayed?	Replace the airbag control module. <Ref. to AB-22, Airbag Control Module.>	Go to step 7.
7 CHECK FOR ANY OTHER DTC ON DISPLAY.	Is any other DTC displayed?	Check DTC using "List of Diagnostic Trouble Code (DTC)". <Ref. to AB(diag)-42, List of Diagnostic Trouble Code (DTC).>	Finish the diagnosis.

Diagnostic Chart with Trouble Code

AIRBAG SYSTEM (DIAGNOSTICS)

Brought to you by Eris Studios
NOT FOR SALE

AJ:DTC 95 CURTAIN AIRBAG MODULE RH FAILURE

DTC DETECTING CONDITION:

- Curtain airbag harness (RH) is shorted to power supply.
- Airbag control module is faulty.

CAUTION:

- Before diagnosing the airbag system, be sure to turn the ignition switch to OFF, disconnect the ground terminal from battery, and wait 20 seconds or more before starting to work.
- When replacing the airbag module, seat belt pretensioner, roll connector, control module and sensor, reconnect each part and check that the warning light operates properly.
- When inspecting the airbag main harness, disconnect the airbag module connectors of the driver's and passenger's seats for safety.
- When inspecting the airbag rear harness, disconnect the side airbag module connector, curtain airbag module connector and seat belt pretensioner connector for safety reasons.

WIRING DIAGRAM:

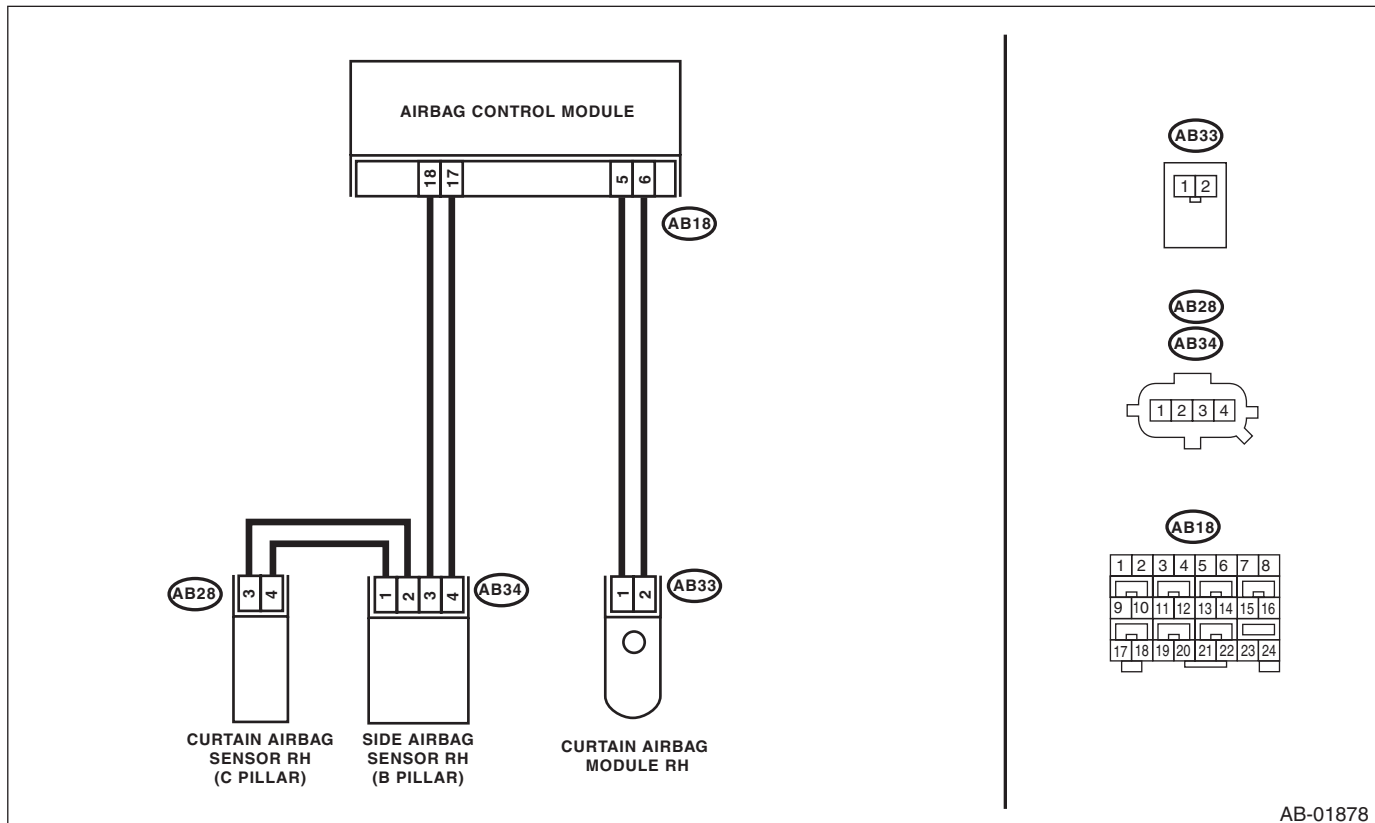

AB-01878

Diagnostic Chart with Trouble Code

AIRBAG SYSTEM (DIAGNOSTICS)

Brought to you by Eris Studios
NOT FOR RESALE

Step	Check	Yes	No
1 CHECK POOR CONTACT IN CONNECTORS. Check for poor contact of the connectors between the airbag control module, curtain airbag module RH and the curtain airbag sensor RH.	Is there poor contact?	Replace the airbag rear harness along with body harness.	Go to step 2.
2 CHECK CURTAIN AIRBAG MODULE. 1) Turn the ignition switch to OFF, disconnect the battery ground cable, and wait for 20 seconds or more. 2) Disconnect the connector (AB33), and connect the connector (1N) in test harness N to connector (AB33). 3) Connect the airbag resistor to the connector (2N) of test harness N. 4) Connect the battery ground terminal and turn the ignition switch to ON.	Does the airbag warning light illuminate for 6 seconds and go off?	Replace the curtain airbag module (RH). <Ref. to AB-20, Curtain Airbag Module.>	Go to step 3.
3 CHECK AIRBAG REAR HARNESS (CURTAIN AIRBAG MODULE HARNESS RH). 1) Turn the ignition switch to OFF, disconnect the battery ground cable, and wait for 20 seconds or more. 2) Disconnect the connector (AB26) from seat belt pretensioner (RH). 3) Disconnect connector (AB24) from side airbag module (RH). 4) Disconnect the airbag resistor from test harness N. 5) Disconnect the connectors (AB6, AB17, and AB18) from airbag control module. 6) Connect the connector (1AG) in the test harness AG to the connectors (AB6, AB17, and AB18). 7) Connect the battery ground terminal and turn the ignition switch to ON. 8) Measure the voltage between connector (6AG) in the test harness AG and chassis ground. Connector & terminal (6AG) No. 6 (+) — Chassis ground (-): (6AG) No. 8 (+) — Chassis ground (-):	Is the voltage less than 1 V?	Go to step 4.	Replace the airbag rear harness along with body harness.
4 CHECK AIRBAG CONTROL MODULE. 1) Connect all connectors. 2) Erase the memory. 3) Perform the Inspection Mode. 4) Read the DTC.	Is the same DTC displayed?	Replace the airbag control module. <Ref. to AB-22, Airbag Control Module.>	Go to step 5.
5 CHECK FOR ANY OTHER DTC ON DISPLAY.	Is any other DTC displayed?	Check DTC using "List of Diagnostic Trouble Code (DTC)". <Ref. to AB(diag)-42, List of Diagnostic Trouble Code (DTC).>	Finish the diagnosis.

Diagnostic Chart with Trouble Code

AIRBAG SYSTEM (DIAGNOSTICS)

Brought to you by Eris Studios
NOT FOR SALE

AK:DTC 96 CURTAIN AIRBAG MODULE LH FAILURE

DTC DETECTING CONDITION:

- Curtain airbag harness (LH) is shorted to power supply.
- Airbag control module is faulty.

CAUTION:

- Before diagnosing the airbag system, be sure to turn the ignition switch to OFF, disconnect the ground terminal from battery, and wait 20 seconds or more before starting to work.
- When replacing the airbag module, seat belt pretensioner, roll connector, control module and sensor, reconnect each part and check that the warning light operates properly.
- When inspecting the airbag main harness, disconnect the airbag module connectors of the driver's and passenger's seats for safety.
- When inspecting the airbag rear harness, disconnect the side airbag module connector, curtain airbag module connector and seat belt pretensioner connector for safety reasons.

WIRING DIAGRAM:

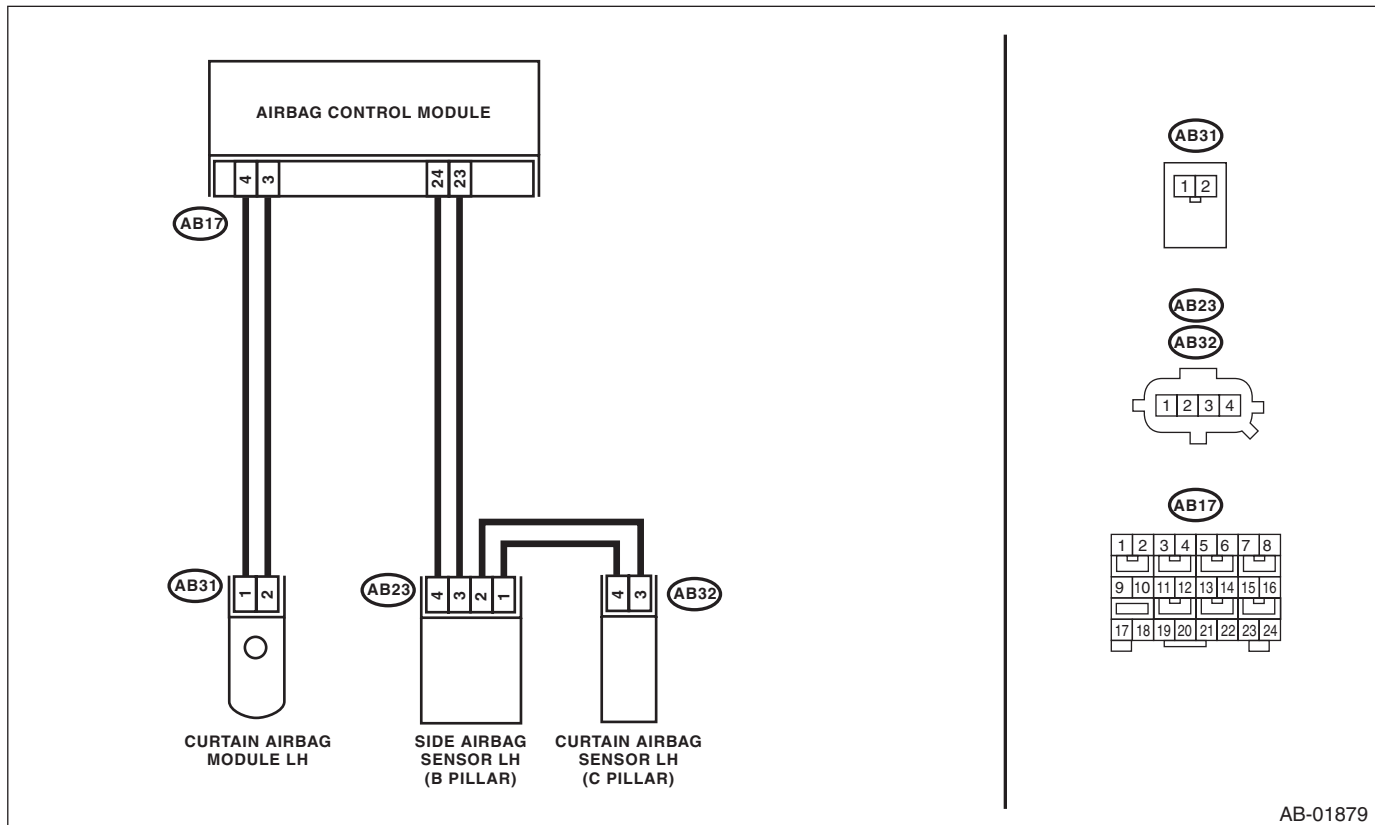

AB-01879

Step	Check	Yes	No
1 CHECK POOR CONTACT IN CONNECTORS. Check for poor contact of the connectors between the airbag control module, curtain airbag module LH and the curtain airbag sensor LH.	Is there poor contact?	Replace the airbag rear harness along with body harness.	Go to step 2.
2 CHECK SIDE AIRBAG MODULE. 1) Turn the ignition switch to OFF, disconnect the battery ground cable, and wait for 20 seconds or more. 2) Disconnect the connectors (AB31) and (AB39), and connect the connector (1N) in test harness N to connector (AB31). 3) Connect the airbag resistor to the connector (2N) of test harness N. 4) Connect the battery ground terminal and turn the ignition switch to ON.	Does the airbag warning light illuminate for 6 seconds and go off?	Replace the curtain airbag module (LH). <Ref. to AB-20, Curtain Airbag Module.>	Go to step 3.

Diagnostic Chart with Trouble Code

AIRBAG SYSTEM (DIAGNOSTICS)

Brought to you by Eris Studios
NOT FOR RESALE

Step	Check	Yes	No
3 CHECK AIRBAG REAR HARNESS (CURTAIN AIRBAG MODULE HARNESS LH). 1) Turn the ignition switch to OFF, disconnect the battery ground cable, and wait for 20 seconds or more. 2) Disconnect the connector (AB21) from seat belt pretensioner (LH). 3) Disconnect connector (AB19) from side airbag module (LH). 4) Disconnect the airbag resistor from test harness N. 5) Disconnect the connectors (AB6, AB17, and AB18) from airbag control module. 6) Connect the connector (1AG) in the test harness AG to the connectors (AB6, AB17, and AB18). 7) Connect the battery ground terminal and turn the ignition switch to ON. 8) Measure the voltage between connector (3AG) in the test harness AG and chassis ground. <i>Connector & terminal</i> <i>(3AG) No. 1 (+) — Chassis ground (-):</i> <i>(3AG) No. 3 (+) — Chassis ground (-):</i>	Is the voltage less than 1 V?	Go to step 4.	Replace the airbag rear harness along with body harness.
4 CHECK AIRBAG CONTROL MODULE. 1) Connect all connectors. 2) Erase the memory. 3) Perform the Inspection Mode. 4) Read the DTC.	Is the same DTC displayed?	Replace the airbag control module. <Ref. to AB-22, Airbag Control Module.>	Go to step 5.
5 CHECK FOR ANY OTHER DTC ON DISPLAY.	Is any other DTC displayed?	Check DTC using "List of Diagnostic Trouble Code (DTC)". <Ref. to AB(diag)-42, List of Diagnostic Trouble Code (DTC).>	Finish the diagnosis.

AL:DTC E2 FRONT SENSOR BUS RH COMMUNICATION ERROR

NOTE:

Refer to DTC E4 for details on DTC E2. <Ref. to AB(diag)-101, DTC E4 FRONT SENSOR BUS RH COMMUNICATION ERROR, Diagnostic Chart with Trouble Code.>

AM:DTC E3 FRONT SENSOR BUS RH COMMUNICATION ERROR

NOTE:

Refer to DTC E4 for details on DTC E3. <Ref. to AB(diag)-101, DTC E4 FRONT SENSOR BUS RH COMMUNICATION ERROR, Diagnostic Chart with Trouble Code.>

Diagnostic Chart with Trouble Code

AIRBAG SYSTEM (DIAGNOSTICS)

Brought to you by Eris Studios
NOT FOR SALE

AN:DTC E4 FRONT SENSOR BUS RH COMMUNICATION ERROR

DTC DETECTING CONDITION:

- Open or short circuit in harness of front sensor bus (RH).
- Front sub sensor (RH) is faulty.
- Airbag control module is faulty.

CAUTION:

- Before diagnosing the airbag system, be sure to turn the ignition switch to OFF, disconnect the ground cable from battery, and wait 20 seconds or more before starting to work.
- When replacing the airbag module, seat belt pretensioner, roll connector, control module and sensor, reconnect each part and check that the warning light operates properly.
- When inspecting the airbag main harness, disconnect the airbag module connectors and seat belt pretensioners of the driver's and passenger's seats for safety reasons.

WIRING DIAGRAM:

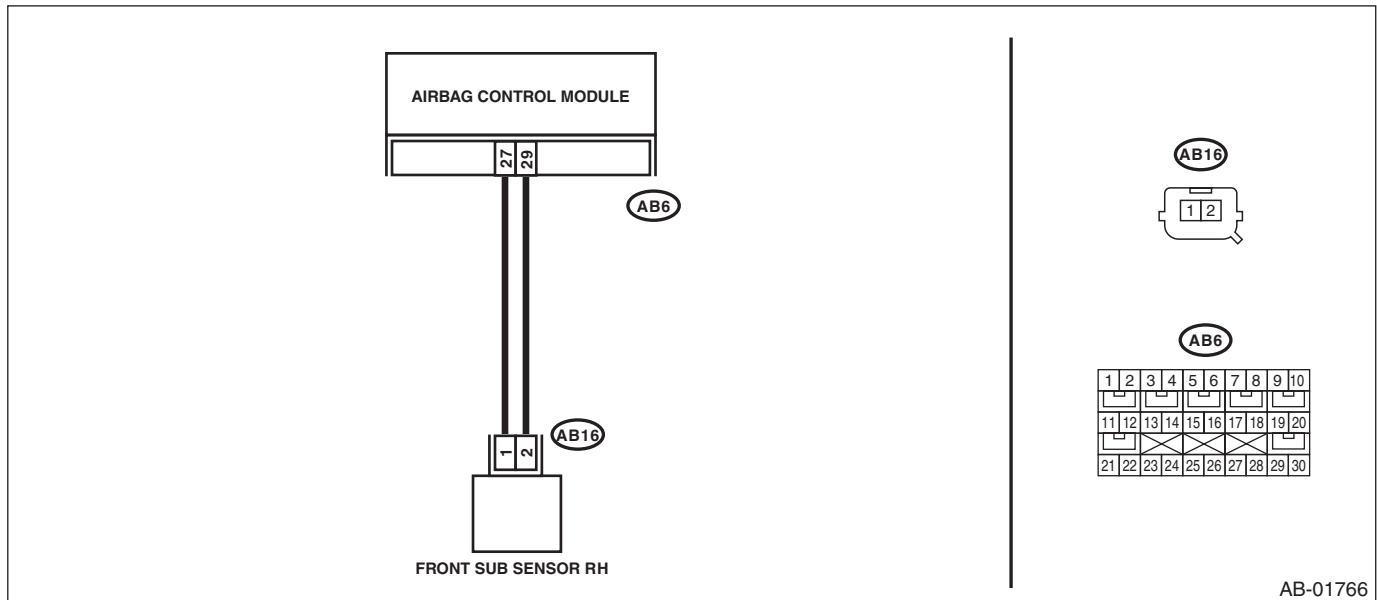

AB-01766

Diagnostic Chart with Trouble Code

AIRBAG SYSTEM (DIAGNOSTICS)

Brought to you by Eris Studios
NOT FOR RESALE

Step	Check	Yes	No
1 CHECK POOR CONTACT OF CONNECTORS. Check for poor contact of the connectors (AB6, AB16) between the airbag control module and the front sub sensor (RH).	Is there poor contact?	Replace the airbag main harness along with body harness.	Go to step 2.
2 CHECK AIRBAG MAIN HARNESS (FRONT SENSOR BUS RH). 1) Turn the ignition switch to OFF, disconnect the ground cable from battery, and wait for 20 seconds or more. 2) Remove the instrument panel lower cover and disconnect the connectors (AB7) and (AB2). 3) Remove the instrument panel side cover on the passenger's side and disconnect the connectors (AB10) and (AB9). 4) Disconnect the connectors (AB17, AB6, AB18) from airbag control module. 5) Connect the connector (1AG) in the test harness AG to the connectors (AB17, AB6, AB18). 6) Disconnect the front sub sensor (RH), and then connect the connector (1H) in the test harness H to connector (AB16). 7) Measure the resistance between connector (4AG) in the test harness AG and connector (3H) in the test harness H. Connector & terminal (4AG) No. 14 — (3H) No. 5: (4AG) No. 12 — (3H) No. 6:	Is the resistance less than 10 Ω?	Go to step 3.	Replace the airbag main harness along with body harness.
3 CHECK AIRBAG MAIN HARNESS (FRONT SENSOR BUS RH). Measure the resistance between connector (4AG) in the test harness AG and chassis ground, and the resistance between connector (4AG) in the test harness AG and connector (3H) in test harness H. Connector & terminal (4AG) No. 14 — Chassis ground: (4AG) No. 12 — Chassis ground: (4AG) No. 14 — (4AG) No. 12:	Is the resistance 1 MΩ or more?	Go to step 4.	Replace the airbag main harness along with body harness.
4 CHECK AIRBAG CONTROL MODULE. 1) Connect all connectors. 2) Erase the memory. 3) Perform the Inspection Mode. 4) Read the DTC.	Is the same DTC displayed?	Replace the front sub sensor (RH). <Ref. to AB-23, REMOVAL, Front Sub Sensor.> Replace the airbag control module if not operating normally even after replacing the sensor. <Ref. to AB-22, REMOVAL, Airbag Control Module.>	Go to step 5.
5 CHECK FOR ANY OTHER DTC ON DISPLAY.	Is any other DTC displayed?	Check DTC using "List of Diagnostic Trouble Code". <Ref. to AB(diag)-42, LIST, List of Diagnostic Trouble Code (DTC).>	Finish the diagnosis.

Diagnostic Chart with Trouble Code

AIRBAG SYSTEM (DIAGNOSTICS)

Brought to you by Eris Studios
NOT FOR SALE

AO:DTC E6 FRONT SENSOR BUS LH COMMUNICATION ERROR

NOTE:

Refer to DTC E8 for details on DTC E6. <Ref. to AB(diag)-104, DTC E8 FRONT SENSOR BUS LH COMMUNICATION ERROR, Diagnostic Chart with Trouble Code.>

AP:DTC E7 FRONT SENSOR BUS LH COMMUNICATION ERROR

NOTE:

Refer to DTC E8 for details on DTC E7. <Ref. to AB(diag)-104, DTC E8 FRONT SENSOR BUS LH COMMUNICATION ERROR, Diagnostic Chart with Trouble Code.>

Diagnostic Chart with Trouble Code

AIRBAG SYSTEM (DIAGNOSTICS)

Brought to you by Eris Studios
NOT FOR RESALE

AQ:DTC E8 FRONT SENSOR BUS LH COMMUNICATION ERROR

DTC DETECTING CONDITION:

- Open or short circuit in harness of front sensor bus (LH).
- Front sub sensor (LH) is faulty.
- Airbag control module is faulty.

CAUTION:

- Before diagnosing the airbag system, be sure to turn the ignition switch to OFF, disconnect the ground cable from battery, and wait 20 seconds or more before starting to work.
- When replacing the airbag module, seat belt pretensioner, roll connector, control module and sensor, reconnect each part and check that the warning light operates properly.
- When inspecting the airbag main harness, disconnect the airbag module connectors and seat belt pretensioners of the driver's and passenger's seats for safety reasons.

WIRING DIAGRAM:

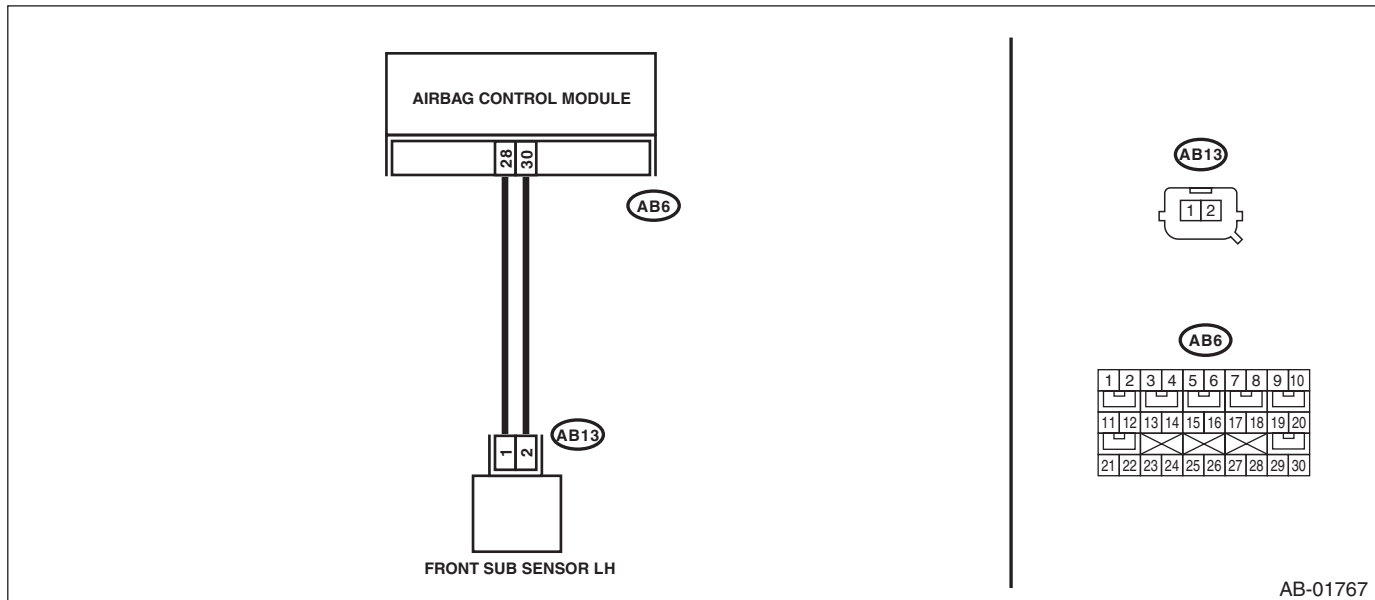

Diagnostic Chart with Trouble Code

AIRBAG SYSTEM (DIAGNOSTICS)

Brought to you by Eris Studios
NOT FOR RESALE

Step	Check	Yes	No
1 CHECK POOR CONTACT OF CONNECTORS. Check for poor contact of the connectors (AB6, AB13) between the airbag control module and the front sub sensor (LH).	Is there poor contact?	Replace the airbag main harness along with body harness.	Go to step 2.
2 CHECK AIRBAG MAIN HARNESS (FRONT SENSOR BUS LH). 1) Turn the ignition switch to OFF, disconnect the ground cable from battery, and wait for 20 seconds or more. 2) Remove the instrument panel lower cover and disconnect the connectors (AB7) and (AB2). 3) Remove the instrument panel side cover on the passenger's side and disconnect the connectors (AB9) and (AB10). 4) Disconnect the connectors (AB17, AB6, AB18) from airbag control module. 5) Connect the connector (1AG) in the test harness AG to the connectors (AB17, AB6, AB18). 6) Disconnect the front sub sensor (LH), and then connect the connector (1H) in the test harness H to connector (AB13). 7) Measure the resistance between connector (4AG) in the test harness AG and connector (3H) in the test harness H. Connector & terminal (4AG) No. 7 — (3H) No. 5: (4AG) No. 9 — (3H) No. 6:	Is the resistance less than 10 Ω?	Go to step 3.	Replace the airbag main harness along with body harness.
3 CHECK AIRBAG MAIN HARNESS (FRONT SENSOR BUS LH). Measure the resistance between connector (4AG) in the test harness AG and chassis ground, and the resistance between connector (4AG) in the test harness AG and connector (3H) in test harness H. Connector & terminal (4AG) No. 7 — Chassis ground: (4AG) No. 9 — Chassis ground: (4AG) No. 7 — (4AG) No. 9:	Is the resistance 1 MΩ or more?	Go to step 4.	Replace the airbag main harness along with body harness.
4 CHECK AIRBAG CONTROL MODULE. 1) Connect all connectors. 2) Erase the memory. 3) Perform the Inspection Mode. 4) Read the DTC.	Is the same DTC displayed?	Replace the front sub sensor (LH). <Ref. to AB-23, REMOVAL, Front Sub Sensor.> Replace the airbag control module if not operating normally even after replacing the sensor. <Ref. to AB-22, REMOVAL, Airbag Control Module.>	Go to step 5.
5 CHECK FOR ANY OTHER DTC ON DISPLAY.	Is any other DTC displayed?	Check DTC using "List of Diagnostic Trouble Code". <Ref. to AB(diag)-42, LIST, List of Diagnostic Trouble Code (DTC).>	Finish the diagnosis.

Diagnostic Chart with Trouble Code

AIRBAG SYSTEM (DIAGNOSTICS)

Brought to you by Eris Studios
NOT FOR RESALE

AR:DTC E9 SIDE SENSOR BUS RH COMMUNICATION ERROR

NOTE:

Refer to DTC EC for details on DTC E9. <Ref. to AB(diag)-107, DTC EC SIDE SENSOR BUS RH COMMUNICATION ERROR, Diagnostic Chart with Trouble Code.>

AS:DTC EA SIDE SENSOR BUS RH COMMUNICATION ERROR

NOTE:

Refer to DTC EC for details on DTC EA. <Ref. to AB(diag)-107, DTC EC SIDE SENSOR BUS RH COMMUNICATION ERROR, Diagnostic Chart with Trouble Code.>

AT:DTC EB SIDE SENSOR BUS RH COMMUNICATION ERROR

NOTE:

Refer to DTC EC for details on DTC EB. <Ref. to AB(diag)-107, DTC EC SIDE SENSOR BUS RH COMMUNICATION ERROR, Diagnostic Chart with Trouble Code.>

Diagnostic Chart with Trouble Code

AIRBAG SYSTEM (DIAGNOSTICS)

Brought to you by Eris Studios
NOT FOR SALE

AU:DTC EC SIDE SENSOR BUS RH COMMUNICATION ERROR

DTC DETECTING CONDITION:

- Open or short circuit in harness of side sensor bus (RH).
- Side A/B sensor (RH) and curtain airbag sensor (RH) is faulty.
- Airbag control module is faulty.

CAUTION:

- Before diagnosing the airbag system, be sure to turn the ignition switch to OFF, disconnect the ground cable from battery, and wait 20 seconds or more before starting to work.
- When replacing the airbag module, seat belt pretensioner, roll connector, control module and sensor, reconnect each part and check that the warning light operates properly.
- When inspecting the airbag main harness, disconnect the airbag module connectors and seat belt pretensioners of the driver's and passenger's seats for safety reasons.
- When inspecting the airbag rear harness, disconnect the side airbag module connector, curtain airbag module connector and seat belt pretensioner connector for safety reasons.

WIRING DIAGRAM:

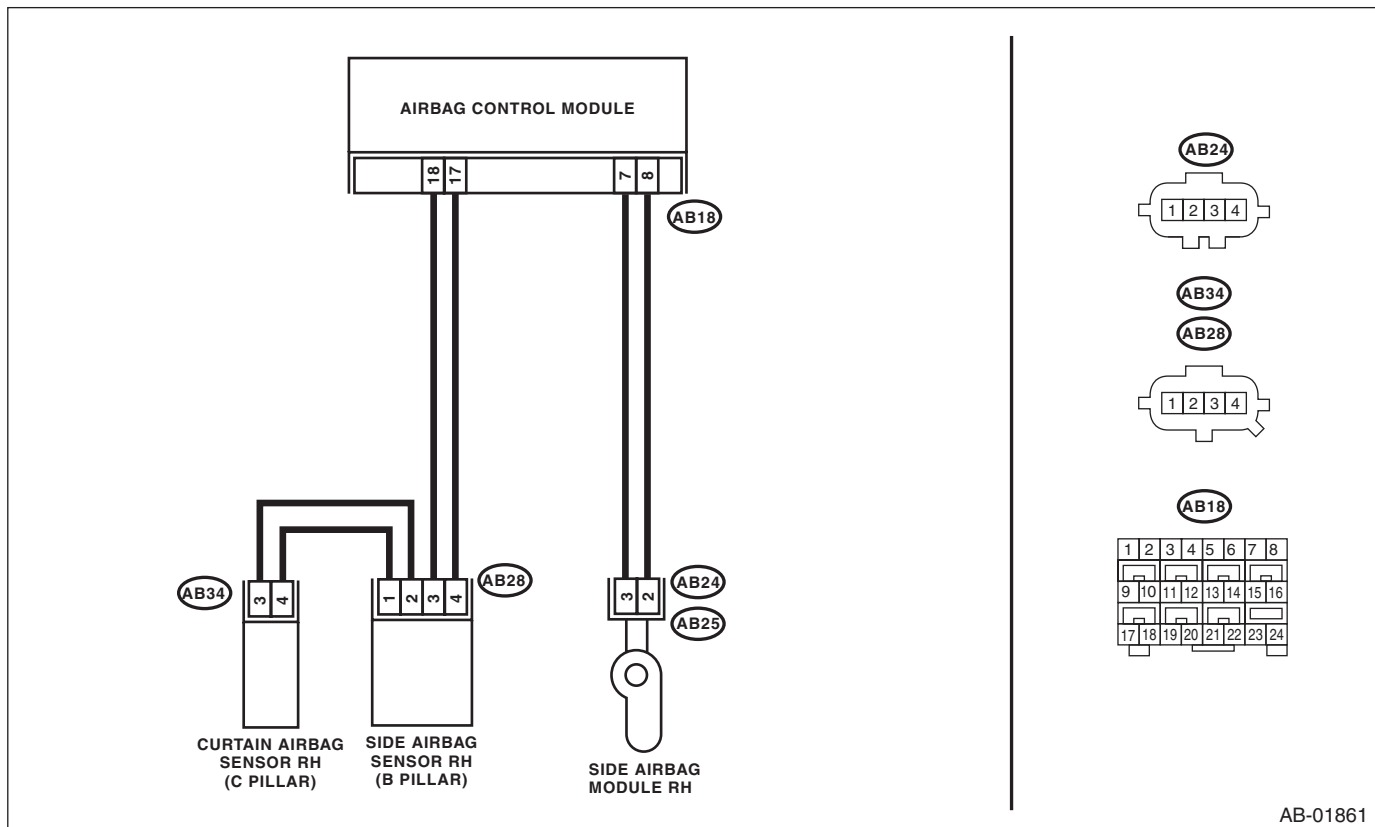

AB-01861

Step	Check	Yes	No	
1	CHECK POOR CONTACT OF CONNECTORS. Check for poor contact of the connectors (AB18, AB28, AB34) between the airbag control module and the curtain A/B sensor (RH).	Is there poor contact?	Replace the airbag rear harness along with body harness.	Go to step 2.

Diagnostic Chart with Trouble Code

AIRBAG SYSTEM (DIAGNOSTICS)

Brought to you by Eris Studios
NOT FOR RESALE

Step	Check	Yes	No
<p>2</p> <p>CHECK AIRBAG REAR HARNESS (BETWEEN AIRBAG CONTROL MODULE AND SIDE A/B SENSOR RH).</p> <p>1) Turn the ignition switch to OFF, disconnect the ground cable from battery, and wait for 20 seconds or more.</p> <p>2) Disconnect the connector (AB26) from seat belt pretensioner (RH).</p> <p>3) Disconnect the connector (AB33) from curtain airbag module (RH).</p> <p>4) Disconnect connectors (AB25) and (AB24) from side airbag module (RH).</p> <p>5) Disconnect the connectors (AB17, AB6, AB18) from airbag control module.</p> <p>6) Connect the connector (1AG) in the test harness AG to the connectors (AB17, AB6, AB18).</p> <p>7) Disconnect the connector (AB28) from side airbag sensor (RH), and connect the connector (2V) in test harness V to connector (AB28).</p> <p>8) Measure the resistance between connector (5AG) in the test harness AG and connector (3V) in the test harness V.</p> <p>Connector & terminal (5AG) No. 16 — (3V) No. 2: (5AG) No. 14 — (3V) No. 1:</p>	Is the resistance less than 10 Ω?	Go to step 3.	Replace the airbag rear harness along with body harness.
<p>3</p> <p>CHECK AIRBAG REAR HARNESS (BETWEEN AIRBAG CONTROL MODULE AND SIDE A/B SENSOR RH).</p> <p>Measure the resistance between connector (5AG) in the test harness AG and chassis ground, and the resistance between connector (5AG) in the test harness AG and connector (3V) in test harness V.</p> <p>Connector & terminal (5AG) No. 16 — Chassis ground: (5AG) No. 14 — Chassis ground: (5AG) No. 16 — (5AG) No. 14:</p>	Is the resistance 1 MΩ or more?	Go to step 4.	Replace the airbag rear harness along with body harness.
<p>4</p> <p>CHECK AIRBAG REAR HARNESS (BETWEEN SIDE A/B SENSOR AND CURTAIN A/B SENSOR RH).</p> <p>1) Disconnect the connector (2V) in the test harness V from the connector (AB28) of side airbag sensor (RH).</p> <p>2) Connect the connector (AB28) of side airbag sensor (RH) and the connector (1AI) in the test harness AI.</p> <p>3) Connect the connector (2AI) in the test harness AI and the connector (1V) in the test harness V.</p> <p>4) Disconnect the connector (AB34) from curtain airbag sensor (RH), and connect the connector (2V) in test harness V to connector (AB34).</p> <p>5) Measure the resistance between connector (3V) terminals in the test harness V.</p> <p>Connector & terminal (3V) No. 2 — (3V) No. 6: (3V) No. 1 — (3V) No. 7:</p>	Is the resistance less than 10 Ω?	Go to step 5.	Replace the airbag rear harness along with body harness.

Diagnostic Chart with Trouble Code

AIRBAG SYSTEM (DIAGNOSTICS)

Brought to you by Eris Studios
NOT FOR SALE

Step	Check	Yes	No
5 CHECK AIRBAG REAR HARNESS (BETWEEN SIDE A/B SENSOR AND CURTAIN A/B SENSOR RH). Measure the resistance between connector (3V) in test harness V and chassis ground, and the resistance between connector (3V) in test harness V. Connector & terminal (3V) No. 2 — Chassis ground: (3V) No. 1 — Chassis ground: (3V) No. 2 — (3V) No. 1:	Is the resistance 1 MΩ or more?	Go to step 6.	Replace the airbag rear harness along with body harness.
6 CHECK AIRBAG CONTROL MODULE. 1) Connect all connectors. 2) Erase the memory. 3) Perform the Inspection Mode. 4) Read the DTC.	Is the same DTC displayed?	Go to step 7.	Go to step 8.
7 REPLACE SIDE AIRBAG SENSOR (RH) AND CHECK AIRBAG CONTROL MODULE AFTER REPLACEMENT. <Ref. to AB-24, REMOVAL, Side Airbag Sensor.> 1) Connect all connectors. 2) Erase the memory. 3) Perform the Inspection Mode. 4) Read the DTC.	Is the system normal?	Go to step 8.	Replace the curtain airbag sensor (RH). <Ref. to AB-25, REMOVAL, Curtain Airbag Sensor.> Replace the airbag control module if not operating normally even after replacing the sensor. <Ref. to AB-22, REMOVAL, Airbag Control Module.>
8 CHECK FOR ANY OTHER DTC ON DISPLAY.	Is any other DTC displayed?	Check DTC using "List of Diagnostic Trouble Code (DTC)". <Ref. to AB(diag)-42, List of Diagnostic Trouble Code (DTC).>	Finish the diagnosis.

AV:DTC ED SIDE SENSOR BUS RH COMMUNICATION ERROR

NOTE:

Refer to DTC EE for details on DTC ED. <Ref. to AB(diag)-110, DTC EE SIDE SENSOR BUS RH COMMUNICATION ERROR, Diagnostic Chart with Trouble Code.>

Diagnostic Chart with Trouble Code

AIRBAG SYSTEM (DIAGNOSTICS)

Brought to you by Eris Studios
NOT FOR RESALE

AW:DTC EE SIDE SENSOR BUS RH COMMUNICATION ERROR

DTC DETECTING CONDITION:

- Open or short circuit in harness of side sensor bus (RH).
- Side A/B sensor (RH) or curtain airbag sensor (RH) is faulty
- Airbag control module is faulty.

CAUTION:

- Before diagnosing the airbag system, be sure to turn the ignition switch to OFF, disconnect the ground cable from battery, and wait 20 seconds or more before starting to work.
- When replacing the airbag module, seat belt pretensioner, roll connector, control module and sensor, reconnect each part and check that the warning light operates properly.
- When inspecting the airbag main harness, disconnect the airbag module connectors and seat belt pretensioners of the driver's and passenger's seats for safety reasons.
- When inspecting the airbag rear harness, disconnect the side airbag module connector, curtain airbag module connector and seat belt pretensioner connector for safety reasons.

WIRING DIAGRAM:

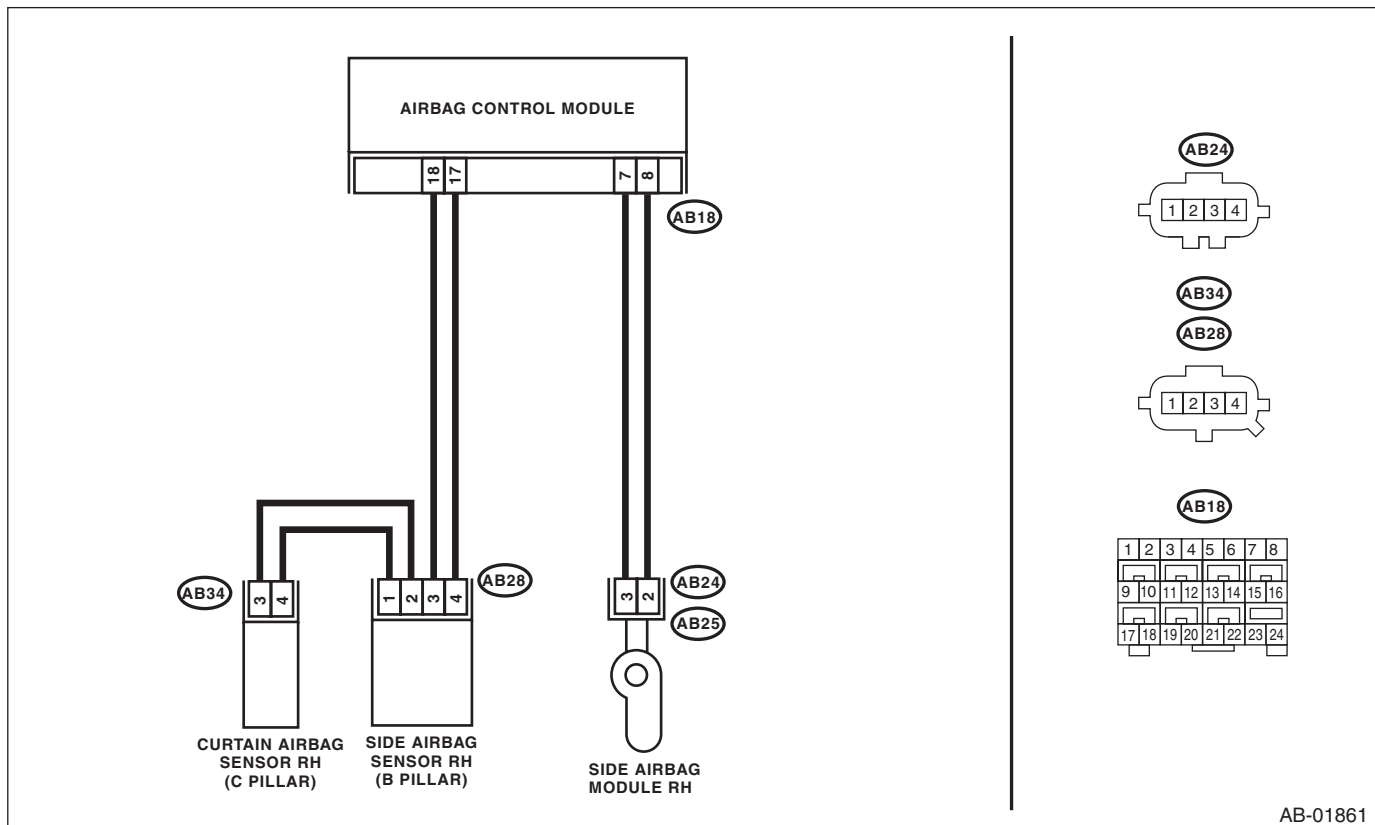

Diagnostic Chart with Trouble Code

AIRBAG SYSTEM (DIAGNOSTICS)

Brought to you by Eris Studios
NOT FOR SALE

Step	Check	Yes	No
1 CHECK POOR CONTACT OF CONNECTORS. Check for poor contact of the connectors (AB18, AB28, AB34) between the airbag control module and the curtain A/B sensor (RH).	Is there poor contact?	Replace the airbag rear harness along with body harness.	Go to step 2.
2 CHECK AIRBAG REAR HARNESS (BETWEEN SIDE A/B SENSOR (RH) AND CURTAIN A/B SENSOR (RH)). 1) Turn the ignition switch to OFF, disconnect the ground cable from battery, and wait for 20 seconds or more. 2) Disconnect the connector (AB26) from seat belt pretensioner (RH). 3) Disconnect the connector (AB33) from curtain airbag module (RH). 4) Disconnect connectors (AB25) and (AB24) from side airbag module (RH). 5) Disconnect connector (AB28) from side airbag sensor (RH). 6) Connect the connector (AB28) of side airbag sensor (RH) and the connector (1A1) in the test harness A1. 7) Connect the connector (2A1) in the test harness A1 and the connector (1V) in the test harness V. 8) Disconnect the connector (AB34) from curtain airbag sensor (RH), and connect the connector (2V) in test harness V to connector (AB34). 9) Measure the resistance between connector (3V) terminals in the test harness V. Connector & terminal (3V) No. 2 — (3V) No. 6: (3V) No. 1 — (3V) No. 7:	Is the resistance less than 10 Ω?	Go to step 3.	Replace the airbag rear harness along with body harness.
3 CHECK AIRBAG REAR HARNESS (BETWEEN SIDE A/B SENSOR AND CURTAIN A/B SENSOR RH). Measure the resistance between connector (3V) in test harness V and chassis ground, and the resistance between connector (3V) in test harness V. Connector & terminal (3V) No. 2 — Chassis ground: (3V) No. 1 — Chassis ground: (3V) No. 2 — (3V) No. 1:	Is the resistance 1 MΩ or more?	Go to step 4.	Replace the airbag rear harness along with body harness.

Diagnostic Chart with Trouble Code

AIRBAG SYSTEM (DIAGNOSTICS)

Brought to you by Eris Studios
NOT FOR RESALE

Step	Check	Yes	No
<p>4 CHECK AIRBAG REAR HARNESS (BETWEEN AIRBAG CONTROL MODULE AND SIDE A/B SENSOR (RH)).</p> <p>1) Disconnect the connectors (AB17, AB6, AB18) from airbag control module.</p> <p>2) Connect the connector (1AG) in the test harness AG to the connectors (AB17, AB6, AB18).</p> <p>3) Disconnect the connector (AB28) in the side airbag sensor (RH) from the connector (1AI) in the test harness AI.</p> <p>4) Disconnect the connector (2AI) in the test harness AI from the connector (1V) in the test harness V.</p> <p>5) Connect the connector (AB28) of side airbag sensor (RH) and the connector (2V) in the test harness V to the connector (AB28).</p> <p>6) Measure the resistance between connector (5AG) in the test harness AG and connector (3V) in the test harness V.</p> <p>Connector & terminal (5AG) No. 16 — (3V) No. 2: (5AG) No. 14 — (3V) No. 1:</p>	Is the resistance less than 10 Ω?	Go to step 5.	Replace the airbag rear harness along with body harness.
<p>5 CHECK AIRBAG REAR HARNESS (BETWEEN AIRBAG CONTROL MODULE AND SIDE A/B SENSOR RH).</p> <p>Measure the resistance between connector (5AG) in the test harness AG and chassis ground, and the resistance between connector (5AG) in the test harness AG and connector (3V) in test harness V.</p> <p>Connector & terminal (5AG) No. 16 — Chassis ground: (5AG) No. 14 — Chassis ground: (5AG) No. 16 — (5AG) No. 14:</p>	Is the resistance 1 MΩ or more?	Go to step 6.	Replace the airbag rear harness along with body harness.
<p>6 CHECK AIRBAG CONTROL MODULE.</p> <p>1) Connect all connectors.</p> <p>2) Erase the memory.</p> <p>3) Perform the Inspection Mode.</p> <p>4) Read the DTC.</p>	Is the same DTC displayed?	Go to step 7.	Go to step 8.
<p>7 REPLACE SIDE AIRBAG SENSOR (RH) AND CHECK AIRBAG CONTROL MODULE AFTER REPLACEMENT.</p> <p><Ref. to AB-24, REMOVAL, Side Airbag Sensor.></p> <p>1) Connect all connectors.</p> <p>2) Erase the memory.</p> <p>3) Perform the Inspection Mode.</p> <p>4) Read the DTC.</p>	Is the system normal?	Go to step 8.	Replace the curtain airbag sensor (RH). <Ref. to AB-25, REMOVAL, Curtain Airbag Sensor.> Replace the airbag control module if not operating normally even after replacing the sensor. <Ref. to AB-22, REMOVAL, Airbag Control Module.>
<p>8 CHECK FOR ANY OTHER DTC ON DISPLAY.</p>	Is any other DTC displayed?	Check DTC using "List of Diagnostic Trouble Code (DTC)". <Ref. to AB(diag)-42, List of Diagnostic Trouble Code (DTC).>	Finish the diagnosis.

Diagnostic Chart with Trouble Code

AIRBAG SYSTEM (DIAGNOSTICS)

Brought to you by Eris Studios
NOT FOR SALE

AX:DTC F1 SIDE SENSOR BUS LH COMMUNICATION ERROR

NOTE:

Refer to DTC F4 for details on DTC F1. <Ref. to AB(diag)-114, DTC F4 SIDE SENSOR BUS LH COMMUNICATION ERROR, Diagnostic Chart with Trouble Code.>

AY:DTC F2 SIDE SENSOR BUS LH COMMUNICATION ERROR

NOTE:

Refer to DTC F4 for details on DTC F2. <Ref. to AB(diag)-114, DTC F4 SIDE SENSOR BUS LH COMMUNICATION ERROR, Diagnostic Chart with Trouble Code.>

AZ:DTC F3 SIDE SENSOR BUS LH COMMUNICATION ERROR

NOTE:

Refer to DTC F4 for details on DTC F3. <Ref. to AB(diag)-114, DTC F4 SIDE SENSOR BUS LH COMMUNICATION ERROR, Diagnostic Chart with Trouble Code.>

Diagnostic Chart with Trouble Code

AIRBAG SYSTEM (DIAGNOSTICS)

Brought to you by Eris Studios
NOT FOR RESALE

BA:DTC F4 SIDE SENSOR BUS LH COMMUNICATION ERROR

DTC DETECTING CONDITION:

- Open or short circuit in harness of side sensor bus (LH).
- Side A/B sensor (LH) and curtain airbag sensor (LH) is faulty.
- Airbag control module is faulty.

CAUTION:

- Before diagnosing the airbag system, be sure to turn the ignition switch to OFF, disconnect the ground cable from battery, and wait 20 seconds or more before starting to work.
- When replacing the airbag module, seat belt pretensioner, roll connector, control module and sensor, reconnect each part and check that the warning light operates properly.
- When inspecting the airbag main harness, disconnect the airbag module connectors and seat belt pretensioners of the driver's and passenger's seats for safety reasons.
- When inspecting the airbag rear harness, disconnect the side airbag module connector, curtain airbag module connector and seat belt pretensioner connector for safety reasons.

WIRING DIAGRAM:

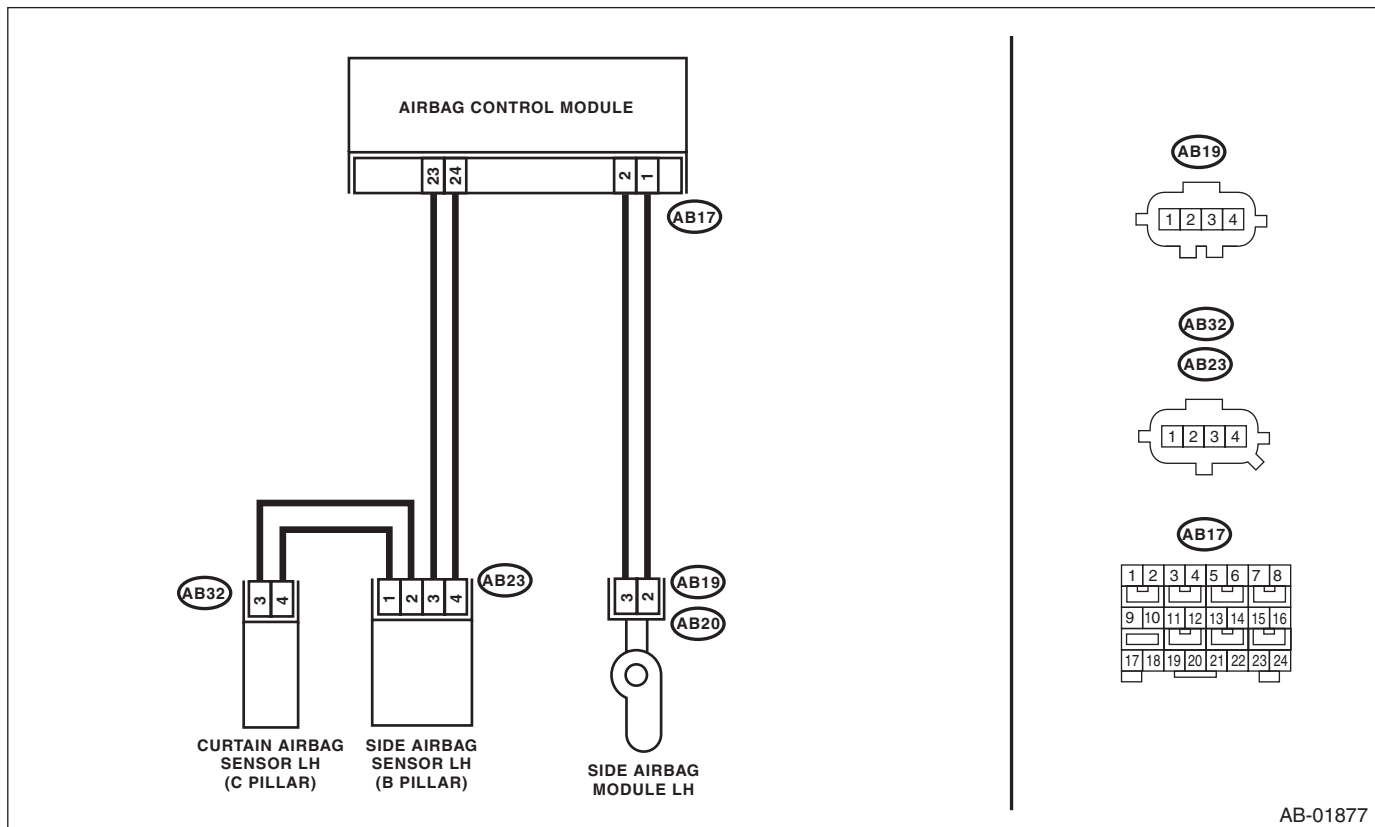

AB-01877

Step	Check	Yes	No
1	CHECK POOR CONTACT OF CONNECTORS. Check for poor contact of the connectors (AB17, AB23, AB32) between the airbag control module and the curtain A/B sensor (LH).	Is there poor contact? Replace the airbag rear harness along with body harness.	Go to step 2.

Diagnostic Chart with Trouble Code

AIRBAG SYSTEM (DIAGNOSTICS)

Brought to you by Eris Studios
NOT FOR SALE

Step	Check	Yes	No
<p>2 CHECK AIRBAG REAR HARNESS (BETWEEN AIRBAG CONTROL MODULE AND SIDE A/B SENSOR (LH)).</p> <p>1) Turn the ignition switch to OFF, disconnect the ground cable from battery, and wait for 20 seconds or more.</p> <p>2) Disconnect the connector (AB21) from seat belt pretensioner (LH).</p> <p>3) Disconnect the connector (AB31) from curtain airbag module (LH).</p> <p>4) Disconnect connectors (AB19) and (AB20) from side airbag module (LH).</p> <p>5) Disconnect the connectors (AB17, AB6, AB18) from airbag control module.</p> <p>6) Connect the connector (1AG) in the test harness AG to the connectors (AB17, AB6, AB18).</p> <p>7) Disconnect the connector (AB23) from side airbag sensor (LH), and connect the connector (2V) in test harness V to connector (AB23).</p> <p>8) Measure the resistance between connector (5AG) in the test harness AG and connector (3V) in the test harness V.</p> <p>Connector & terminal (5AG) No. 10 — (3V) No. 2: (5AG) No. 8 — (3V) No. 1:</p>	<p>Is the resistance less than 10 Ω?</p>	<p>Go to step 3.</p>	<p>Replace the airbag rear harness along with body harness.</p>
<p>3 CHECK AIRBAG REAR HARNESS (BETWEEN AIRBAG CONTROL MODULE AND SIDE A/B SENSOR LH).</p> <p>Measure the resistance between connector (5AG) in the test harness AG and chassis ground, and the resistance between connector (5AG) in the test harness AG and connector (3V) in test harness V.</p> <p>Connector & terminal (5AG) No. 10 — Chassis ground: (5AG) No. 8 — Chassis ground: (5AG) No. 10 — (5AG) No. 8:</p>	<p>Is the resistance 1 MΩ or more?</p>	<p>Go to step 4.</p>	<p>Replace the airbag rear harness along with body harness.</p>
<p>4 CHECK AIRBAG REAR HARNESS (BETWEEN SIDE A/B SENSOR (LH) AND CURTAIN A/B SENSOR (LH)).</p> <p>1) Disconnect the connector (2V) in the test harness V from the connector (AB23) of side airbag sensor (LH).</p> <p>2) Connect the connector (AB23) of side airbag sensor (LH) and the connector (1AI) in the test harness AI.</p> <p>3) Connect the connector (2AI) in the test harness AI and the connector (1V) in the test harness V.</p> <p>4) Disconnect the connector (AB32) from curtain airbag sensor (LH), and connect the connector (2V) in test harness V to connector (AB32).</p> <p>5) Measure the resistance between connector (3V) terminals in the test harness V.</p> <p>Connector & terminal (3V) No. 2 — (3V) No. 6: (3V) No. 1 — (3V) No. 7:</p>	<p>Is the resistance less than 10 Ω?</p>	<p>Go to step 5.</p>	<p>Replace the airbag rear harness along with body harness.</p>

Diagnostic Chart with Trouble Code

AIRBAG SYSTEM (DIAGNOSTICS)

Brought to you by Eris Studios
NOT FOR RESALE

Step	Check	Yes	No
5 CHECK AIRBAG REAR HARNESS (BETWEEN SIDE A/B SENSOR (LH) AND CURTAIN A/B SENSOR (LH)). Measure the resistance between connector (3V) in test harness V and chassis ground, and the resistance between connector (3V) in test harness V. Connector & terminal <i>(3V) No. 2 — Chassis ground:</i> <i>(3V) No. 1 — Chassis ground:</i> <i>(3V) No. 2 — (3V) No. 1:</i>	Is the resistance 1 MΩ or more?	Go to step 6.	Replace the airbag rear harness along with body harness.
6 CHECK AIRBAG CONTROL MODULE. 1) Connect all connectors. 2) Erase the memory. 3) Perform the Inspection Mode. 4) Read the DTC.	Is the same DTC displayed?	Go to step 7.	Go to step 8.
7 REPLACE SIDE AIRBAG SENSOR (LH) AND CHECK AIRBAG CONTROL MODULE AFTER REPLACEMENT. <Ref. to AB-24, REMOVAL, Side Airbag Sensor.> 1) Connect all connectors. 2) Erase the memory. 3) Perform the Inspection Mode. 4) Read the DTC.	Is the system normal?	Go to step 8.	Replace the curtain airbag sensor (LH). <Ref. to AB-25, REMOVAL, Curtain Airbag Sensor.> Replace the airbag control module if not operating normally even after replacing the sensor. <Ref. to AB-22, REMOVAL, Airbag Control Module.>
8 CHECK FOR ANY OTHER DTC ON DISPLAY.	Is any other DTC displayed?	Check DTC using "List of Diagnostic Trouble Code (DTC)". <Ref. to AB(diag)-42, List of Diagnostic Trouble Code (DTC).>	Finish the diagnosis.

BB:DTC F5 SIDE SENSOR BUS LH COMMUNICATION ERROR

NOTE:

Refer to DTC F6 for details on DTC F5. <Ref. to AB(diag)-117, DTC F6 SIDE SENSOR BUS LH COMMUNICATION ERROR, Diagnostic Chart with Trouble Code.>

Diagnostic Chart with Trouble Code

AIRBAG SYSTEM (DIAGNOSTICS)

Brought to you by Eris Studios
NOT FOR SALE

BC:DTC F6 SIDE SENSOR BUS LH COMMUNICATION ERROR

DTC DETECTING CONDITION:

- Open or short circuit in harness of side sensor bus (LH).
- Side A/B sensor (LH) or curtain airbag sensor (LH) is faulty.
- Airbag control module is faulty.

CAUTION:

- Before diagnosing the airbag system, be sure to turn the ignition switch to OFF, disconnect the ground cable from battery, and wait 20 seconds or more before starting to work.
- When replacing the airbag module, seat belt pretensioner, roll connector, control module and sensor, reconnect each part and check that the warning light operates properly.
- When inspecting the airbag main harness, disconnect the airbag module connectors and seat belt pretensioners of the driver's and passenger's seats for safety reasons.
- When inspecting the airbag rear harness, disconnect the side airbag module connector, curtain airbag module connector and seat belt pretensioner connector for safety reasons.

WIRING DIAGRAM:

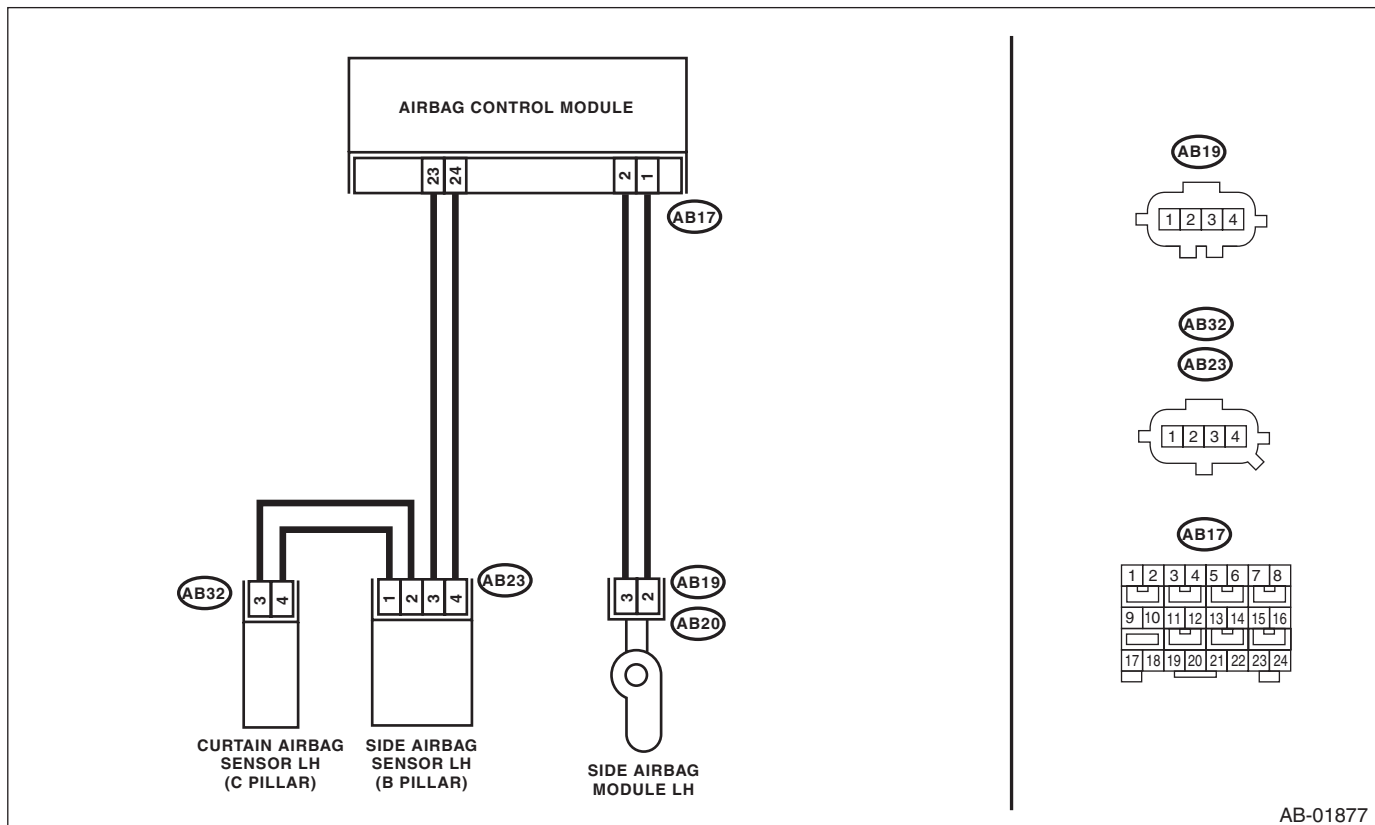

AB-01877

Diagnostic Chart with Trouble Code

AIRBAG SYSTEM (DIAGNOSTICS)

Brought to you by Eris Studios
NOT FOR RESALE

	Step	Check	Yes	No
1	<p>CHECK POOR CONTACT OF CONNECTORS. Check for poor contact of the connectors (AB17, AB23, AB32) between the airbag control module and the curtain A/B sensor (LH).</p>	Is there poor contact?	Replace the airbag rear harness along with body harness.	Go to step 2.
2	<p>CHECK AIRBAG REAR HARNESS (BETWEEN SIDE A/B SENSOR (LH) AND CURTAIN A/B SENSOR (LH)). 1) Turn the ignition switch to OFF, disconnect the ground cable from battery, and wait for 20 seconds or more. 2) Disconnect the connector (AB21) from seat belt pretensioner (LH). 3) Disconnect the connector (AB31) from curtain airbag module (LH). 4) Disconnect connectors (AB19) and (AB20) from side airbag module (LH). 5) Disconnect the connector (AB23) in the side airbag sensor (LH). 6) Connect the connector (AB23) of side airbag sensor (LH) and the connector (1A1) in the test harness A1. 7) Connect the connector (2A1) in the test harness A1 and the connector (1V) in the test harness V. 8) Disconnect the connector (AB32) from curtain airbag sensor (LH), and connect the connector (2V) in test harness V to connector (AB32). 9) Measure the resistance between connector (3V) terminals in the test harness V. Connector & terminal (3V) No. 2 — (3V) No. 6: (3V) No. 1 — (3V) No. 7:</p>	Is the resistance less than 10 Ω?	Go to step 3.	Replace the airbag rear harness along with body harness.
3	<p>CHECK AIRBAG REAR HARNESS (BETWEEN SIDE A/B SENSOR AND CURTAIN A/B SENSOR LH). Measure the resistance between connector (3V) in test harness V and chassis ground, and the resistance between connector (3V) in test harness V. Connector & terminal (3V) No. 6 — Chassis ground: (3V) No. 7 — Chassis ground: (3V) No. 2 — (3V) No. 1:</p>	Is the resistance 1 MΩ or more?	Go to step 4.	Replace the airbag rear harness along with body harness.

Diagnostic Chart with Trouble Code

AIRBAG SYSTEM (DIAGNOSTICS)

Brought to you by Eris Studios
NOT FOR SALE

Step	Check	Yes	No
<p>4 CHECK AIRBAG REAR HARNESS (BETWEEN AIRBAG CONTROL MODULE AND SIDE A/B SENSOR (LH)).</p> <p>1) Disconnect the connectors (AB17, AB6, AB18) from airbag control module.</p> <p>2) Connect the connector (1AG) in the test harness AG to the connectors (AB17, AB6, AB18).</p> <p>3) Disconnect the connector (AB23) in the side airbag sensor (LH) from the connector (1AI) in the test harness AI.</p> <p>4) Disconnect the connector (2AI) in the test harness AI from the connector (1V) in the test harness V.</p> <p>5) Connect the connector (2V) in the test harness V to the connector (AB23).</p> <p>6) Measure the resistance between connector (5AG) in the test harness AG and connector (3V) in the test harness V.</p> <p>Connector & terminal (5AG) No. 10 — (3V) No. 1: (5AG) No. 8 — (3V) No. 2:</p>	Is the resistance less than 10 Ω?	Go to step 5.	Replace the airbag rear harness along with body harness.
<p>5 CHECK AIRBAG REAR HARNESS (BETWEEN SIDE A/B SENSOR (LH) AND CURTAIN A/B SENSOR (LH)).</p> <p>Measure the resistance between connector (3V) in the test harness V and chassis ground, and the resistance between connector (5AG) in the test harness AG and connector (3V) in test harness V.</p> <p>Connector & terminal (3V) No. 2 — Chassis ground: (3V) No. 1 — Chassis ground: (5AG) No. 10 — (5AG) No. 8:</p>	Is the resistance 1 MΩ or more?	Go to step 6.	Replace the airbag rear harness along with body harness.
<p>6 CHECK AIRBAG CONTROL MODULE.</p> <p>1) Connect all connectors.</p> <p>2) Erase the memory.</p> <p>3) Perform the Inspection Mode.</p> <p>4) Read the DTC.</p>	Is the same DTC displayed?	Go to step 7.	Go to step 8.
<p>7 REPLACE SIDE AIRBAG SENSOR (LH) AND CHECK AIRBAG CONTROL MODULE AFTER REPLACEMENT.</p> <p><Ref. to AB-24, REMOVAL, Side Airbag Sensor.></p> <p>1) Connect all connectors.</p> <p>2) Erase the memory.</p> <p>3) Perform the Inspection Mode.</p> <p>4) Read the DTC.</p>	Is the system normal?	Go to step 8.	Replace the curtain airbag sensor (LH). <Ref. to AB-25, REMOVAL, Curtain Airbag Sensor.> Replace the airbag control module if not operating normally even after replacing the sensor. <Ref. to AB-22, REMOVAL, Airbag Control Module.>
<p>8 CHECK FOR ANY OTHER DTC ON DISPLAY.</p>	Is any other DTC displayed?	Check DTC using "List of Diagnostic Trouble Code (DTC)". <Ref. to AB(diag)-42, List of Diagnostic Trouble Code (DTC).>	Finish the diagnosis.

Diagnostic Chart with Trouble Code

AIRBAG SYSTEM (DIAGNOSTICS)

Brought to you by Eris Studios
NOT FOR RESALE

BD:DTC F8 SATELLITE SENSOR BUS COMMUNICATION ERROR

NOTE:

Refer to DTC FA for details on DTC F8. <Ref. to AB(diag)-121, DTC FA SATELLITE SENSOR BUS COMMUNICATION ERROR, Diagnostic Chart with Trouble Code.>

BE:DTC F9 SATELLITE SENSOR BUS COMMUNICATION ERROR

NOTE:

Refer to DTC FA for details on DTC F9. <Ref. to AB(diag)-121, DTC FA SATELLITE SENSOR BUS COMMUNICATION ERROR, Diagnostic Chart with Trouble Code.>

Diagnostic Chart with Trouble Code

AIRBAG SYSTEM (DIAGNOSTICS)

Brought to you by Eris Studios
NOT FOR SALE

BF:DTC FA SATELLITE SENSOR BUS COMMUNICATION ERROR

DTC DETECTING CONDITION:

- Open or short circuit in harness of satellite safing sensor.
- Satellite safing sensor is faulty.
- Airbag control module is faulty.

CAUTION:

- Before diagnosing the airbag system, be sure to turn the ignition switch to OFF, disconnect the ground cable from battery, and wait 20 seconds or more before starting to work.
- When replacing the airbag module, seat belt pretensioner, roll connector, control module and sensor, reconnect each part and check that the warning light operates properly.
- When inspecting the airbag main harness, disconnect the airbag module connectors and seat belt pretensioners of the driver's and passenger's seats for safety reasons.
- When inspecting the airbag rear harness, disconnect the side airbag module connector, curtain airbag module connector and seat belt pretensioner connector for safety reasons.

WIRING DIAGRAM:

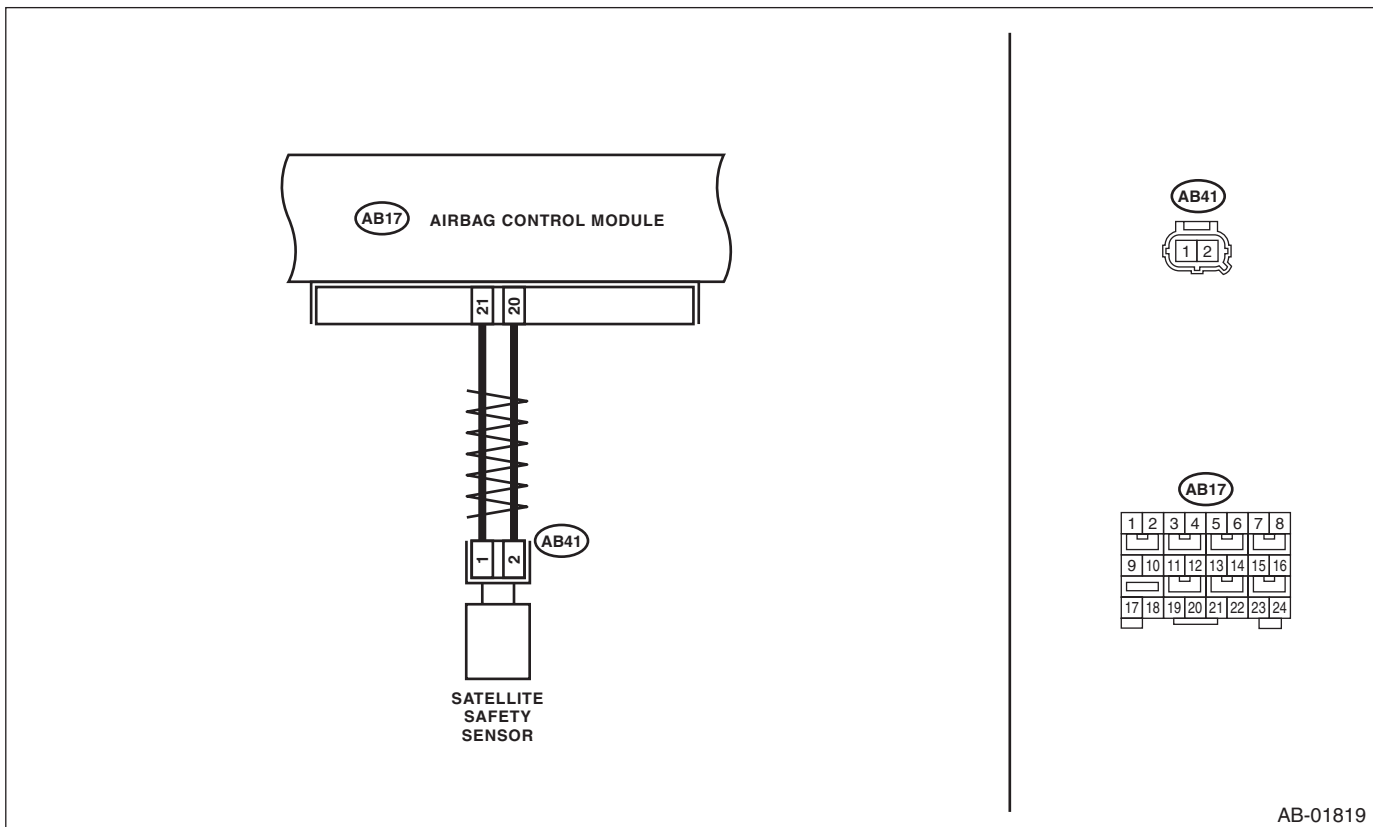

AB-01819

Step	Check	Yes	No	
1	CHECK POOR CONTACT OF CONNECTORS. Check for poor contact of the connectors (AB17, AB41) between the airbag control module and the satellite safing sensor.	Is there poor contact?	Replace the airbag rear harness along with body harness.	Go to step 2.

Diagnostic Chart with Trouble Code

AIRBAG SYSTEM (DIAGNOSTICS)

Brought to you by Eris Studios
NOT FOR RESALE

Step	Check	Yes	No
<p>2 CHECK AIRBAG REAR HARNESS (BETWEEN AIRBAG CONTROL MODULE AND SATELLITE SAFING SENSOR).</p> <p>1) Turn the ignition switch to OFF, disconnect the ground cable from battery, and wait for 20 seconds or more.</p> <p>2) Disconnect the connectors (AB21, AB26) from seat belt pretensioner.</p> <p>3) Disconnect the connectors (AB31, AB33) from curtain airbag module.</p> <p>4) Disconnect the connectors (AB19), (AB20), (AB24) and (AB25) from the side airbag module.</p> <p>5) Disconnect the connectors (AB17, AB6, AB18) from airbag control module.</p> <p>6) Connect the connector (1AG) in the test harness AG to the connectors (AB17, AB6, AB18).</p> <p>7) Disconnect the connector (AB41) from satellite safing sensor, and then connect the connector (1H) in the test harness H to connector (AB41).</p> <p>8) Measure the resistance between connector (5AG) in the test harness AG and connector (3H) in the test harness H.</p> <p>Connector & terminal (5AG) No. 9 — (3H) No. 5: (5AG) No. 11 — (3H) No. 6:</p>	Is the resistance less than 10 Ω?	Go to step 3.	Replace the airbag rear harness along with body harness.
<p>3 CHECK AIRBAG REAR HARNESS (BETWEEN AIRBAG CONTROL MODULE AND SATELLITE SAFING SENSOR).</p> <p>Measure the resistance between connector (5AG) in the test harness AG and chassis ground, and the resistance between connector (5AG) in the test harness AG and connector (3H) in test harness H.</p> <p>Connector & terminal (5AG) No. 9 — Chassis ground: (5AG) No. 11 — Chassis ground: (5AG) No. 9 — (5AG) No. 11:</p>	Is the resistance 1 MΩ or more?	Go to step 4.	Replace the airbag rear harness along with body harness.
<p>4 CHECK AIRBAG CONTROL MODULE.</p> <p>1) Connect all connectors.</p> <p>2) Erase the memory.</p> <p>3) Perform the Inspection Mode.</p> <p>4) Read the DTC.</p>	Is the same DTC displayed?	Replace the satellite safing sensor. <Ref. to AB-26, REMOVAL, Satellite Safing Sensor.> Replace the airbag control module if not operating normally even after replacing the sensor. <Ref. to AB-22, REMOVAL, Airbag Control Module.>	Go to step 5.
<p>5 CHECK FOR ANY OTHER DTC ON DISPLAY.</p>	Is any other DTC displayed?	Check DTC using "List of Diagnostic Trouble Code (DTC)". <Ref. to AB(diag)-42, List of Diagnostic Trouble Code (DTC).>	Finish the diagnosis.

Diagnostic Chart with Trouble Code

AIRBAG SYSTEM (DIAGNOSTICS)

Brought to you by Eris Studios
NOT FOR SALE

BG:DTC 3A FRONT SUB SENSOR RH FALSE INSTALLATION

DTC DETECTING CONDITION:

Front sub sensor (RH) is misinstalled.

Step	Check	Yes	No
1 REPLACE THE FRONT SUB SENSOR. 1) Turn the ignition switch to OFF, disconnect the ground cable from battery, and wait for 20 seconds or more. 2) Replace the front sub sensor (RH) with a genuine sensor. <Ref. to AB-23, REMOVAL, Front Sub Sensor.>	Does the warning light go off?	Finish the diagnosis.	Replace the airbag control module. <Ref. to AB-22, REMOVAL, Airbag Control Module.>

BH:DTC 3B FRONT SUB SENSOR LH FALSE INSTALLATION

DTC DETECTING CONDITION:

Front sub sensor (LH) is misinstalled.

Step	Check	Yes	No
1 REPLACE THE FRONT SUB SENSOR. 1) Turn the ignition switch to OFF, disconnect the ground cable from battery, and wait for 20 seconds or more. 2) Replace the front sub sensor (LH) with a genuine sensor. <Ref. to AB-23, REMOVAL, Front Sub Sensor.>	Does the warning light go off?	Finish the diagnosis.	Replace the airbag control module. <Ref. to AB-22, REMOVAL, Airbag Control Module.>

BI: DTC 3C SATELLITE SENSOR BUS FAILURE

DTC DETECTING CONDITION:

Satellite safing sensor is faulty.

Step	Check	Yes	No
1 REPLACE SATELLITE SAFING SENSOR. 1) Turn the ignition switch to OFF, disconnect the ground cable from battery, and wait for 20 seconds or more. 2) Replace the satellite safing sensor with a genuine sensor. <Ref. to AB-26, REMOVAL, Satellite Safing Sensor.>	Does the warning light go off?	Finish the diagnosis.	Replace the airbag control module. <Ref. to AB-22, REMOVAL, Airbag Control Module.>

BJ:DTC 3D SATELLITE SENSOR FALSE INSTALLATION

DTC DETECTING CONDITION:

Satellite safing sensor is misinstalled.

Step	Check	Yes	No
1 REPLACE SATELLITE SAFING SENSOR. 1) Turn the ignition switch to OFF, disconnect the ground cable from battery, and wait for 20 seconds or more. 2) Replace the satellite safing sensor with a genuine sensor. <Ref. to AB-26, REMOVAL, Satellite Safing Sensor.>	Does the warning light go off?	Finish the diagnosis.	Replace the airbag control module. <Ref. to AB-22, REMOVAL, Airbag Control Module.>

Diagnostic Chart with Trouble Code

AIRBAG SYSTEM (DIAGNOSTICS)

Brought to you by Eris Studios
NOT FOR RESALE

BK:DTC 5A SIDE AIRBAG SENSOR RH FALSE INSTALLATION

DTC DETECTING CONDITION:

Side A/B sensor RH is misinstalled.

Step	Check	Yes	No
1 REPLACE SIDE A/B SENSOR (RH). 1) Turn the ignition switch to OFF, disconnect the ground cable from battery, and wait for 20 seconds or more. 2) Replace the side A/B sensor (RH) with a genuine sensor. <Ref. to AB-24, REMOVAL, Side Airbag Sensor.>	Does the warning light go off?	Finish the diagnosis.	Replace the airbag control module. <Ref. to AB-22, REMOVAL, Airbag Control Module.>

BL:DTC 5B SIDE AIRBAG SENSOR LH FALSE INSTALLATION

DTC DETECTING CONDITION:

Side A/B sensor LH is misinstalled.

Step	Check	Yes	No
1 REPLACE SIDE A/B SENSOR (LH). 1) Turn the ignition switch to OFF, disconnect the ground cable from battery, and wait for 20 seconds or more. 2) Replace the side A/B sensor (LH) with a genuine sensor. <Ref. to AB-24, REMOVAL, Side Airbag Sensor.>	Does the warning light go off?	Finish the diagnosis.	Replace the airbag control module. <Ref. to AB-22, REMOVAL, Airbag Control Module.>

BM:DTC 5C CURTAIN AIRBAG SENSOR RH FALSE INSTALLATION

DTC DETECTING CONDITION:

Curtain A/B sensor RH is misinstalled.

Step	Check	Yes	No
1 REPLACE CURTAIN A/B SENSOR (RH). 1) Turn the ignition switch to OFF, disconnect the ground cable from battery, and wait for 20 seconds or more. 2) Replace the curtain A/B sensor (RH) with a genuine sensor. <Ref. to AB-25, REMOVAL, Curtain Airbag Sensor.>	Does the warning light go off?	Finish the diagnosis.	Replace the airbag control module. <Ref. to AB-22, REMOVAL, Airbag Control Module.>

BN:DTC 5D CURTAIN AIRBAG SENSOR LH FALSE INSTALLATION

DTC DETECTING CONDITION:

Curtain A/B sensor LH is misinstalled.

Step	Check	Yes	No
1 REPLACE CURTAIN A/B SENSOR (LH). 1) Turn the ignition switch to OFF, disconnect the ground cable from battery, and wait for 20 seconds or more. 2) Replace the curtain A/B sensor (LH) with a genuine sensor. <Ref. to AB-25, REMOVAL, Curtain Airbag Sensor.>	Does the warning light go off?	Finish the diagnosis.	Replace the airbag control module. <Ref. to AB-22, REMOVAL, Airbag Control Module.>