

Brought to you by Eris Studios
NOT FOR RESALE

HVAC SYSTEM (AUTO A/C) (DIAGNOSTICS)

Basic Diagnostic Procedure

HVAC SYSTEM (AUTO A/C) (DIAGNOSTICS)

Brought to you by Eris Studios
NOT FOR RESALE

1. Basic Diagnostic Procedure

A: PROCEDURE

	Step	Check	Yes	No
1	START INSPECTIONS. 1) Perform the pre-inspection. <Ref. to AC(diag)-3, INSPECTION, General Description.> 2) Perform the self-diagnosis. <Ref. to AC(diag)-9, OPERATION, Diagnostic Chart for Self-diagnosis.>	Does the self-diagnosis operate?	Go to step 2.	<Ref. to AC(diag)-13, A/C OR SELF DIAGNOSIS FUNCTION FAILS TO OPERATE, Diagnostics for A/C System Malfunction.>
2	IDENTIFY MALFUNCTION PART. Identify the malfunction part with self-diagnosis.	Can the malfunction part be confirmed?	Repair the malfunctioning part in accordance with each diagnostic chart.	Go to step 3.
3	CHECK COMPARTMENT TEMPERATURE. 1) Turn the A/C switch to ON. 2) Turn the temperature control dial at maximum cool position. 3) Check the compartment temperature change.	Does the compartment temperature change?	Go to step 4.	<Ref. to AC(diag)-20, COMPARTMENT TEMPERATURE DOES NOT CHANGE, OR A/C SYSTEM DOES NOT RESPOND PROMPTLY, Diagnostics for A/C System Malfunction.>
4	CHECK A/C SYSTEM RESPONSE. Change the temperature setting, and check the response of A/C system.	Does the A/C system respond quickly?	A/C system is normal.	<Ref. to AC(diag)-20, COMPARTMENT TEMPERATURE DOES NOT CHANGE, OR A/C SYSTEM DOES NOT RESPOND PROMPTLY, Diagnostics for A/C System Malfunction.>

General Description

HVAC SYSTEM (AUTO A/C) (DIAGNOSTICS)

Brought to you by Eris Studios
NOT FOR SALE

2. General Description

A: CAUTION

- 1) Never connect the battery in reverse polarity.
 - Doing so may immediately damage the auto A/C control module.
- 2) Do not disconnect the battery terminals while the engine is running.
 - A large counter electromotive force will be generated in the generator, and this voltage may damage electronic parts such as auto A/C control module etc.
- 3) Before disconnecting the connectors of sensors and the auto A/C control module, be sure to turn off the ignition switch.
 - Auto A/C control module may be damaged.
- 4) Every A/C-related part is a precision part. Do not drop them.
- 5) Airbag system wiring harness is routed near the A/C control panel and junction box.

CAUTION:

- Do not use electrical test equipment on the airbag system wiring harness and connector.
- Be careful not to damage the airbag system wiring harness when servicing the A/C control panel and junction box.

B: INSPECTION

Before performing the diagnosis, check the following items which may cause problems in the A/C system.

1. BATTERY

- 1) Measure the battery voltage and specific gravity of the electrolyte.

Standard voltage:

12 V

Specific gravity:

1.260 or more

- 2) Check the condition of the fuses for A/C system power supply and other fuses.
- 3) Check the condition of harness and harness connector connections.

2. ASPIRATOR HOSE

- 1) Turn the ignition switch to ON, and press the A/C switch.
- 2) Turn the temperature control dial to maximum hot position.
- 3) Set the air flow control dial to the "DEF" position.
- 4) Turn the fan switch to MAX.
- 5) Put a thin strip of paper close to the front side of in-vehicle sensor suction port (A) at the instrument panel lower cover, and check whether the strip becomes drawn towards the port, indicating that air is being drawn in at the port.

NOTE:

Be careful not to let the paper get sucked into the port.

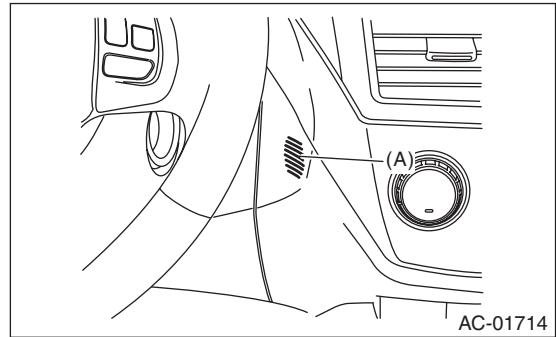

- 6) If the paper strip does not move at all, remove the center console <Ref. to EI-50, INSTRUMENT PANEL, LOWER, REMOVAL, Center Console.>, and check for improper connection of the aspirator hose (A), in-vehicle sensor and heater unit, and repair them if necessary.

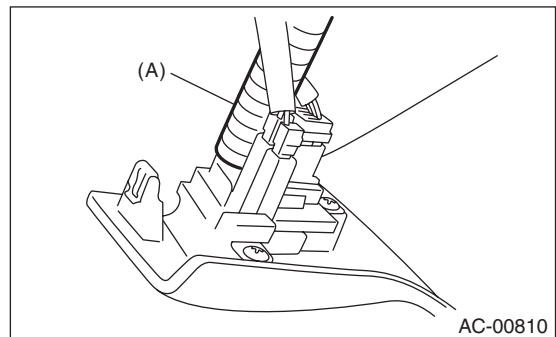

3. A/C LINE

Check the connection for A/C line (A) and lower side high-pressure pipe.

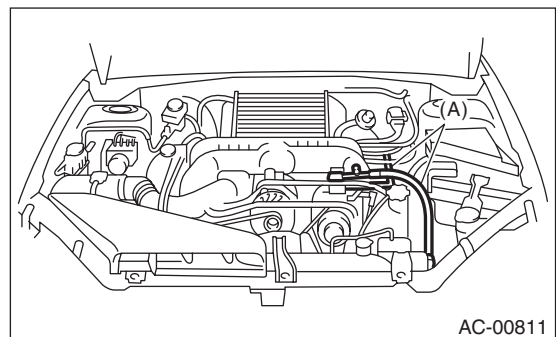

General Description

HVAC SYSTEM (AUTO A/C) (DIAGNOSTICS)

Brought to you by Eris Studios
NOT FOR RESALE

4. CONTROL LINKAGE

- 1) Check the state of mode door linkage.
- 2) Check the state of air mix door linkage.
- 3) Check the state of FRESH/RECIRC door linkage.

5. CONTROL SWITCHES

Start the engine and warm-up completely.

1) Inspection using switches

No.	Point to check	Switch operation	Judgment standard
1	Air flow control dial	Turn the dial to the right.	Outlet opening (mode) switches AUTO → VENT → BI-LEVEL → HEAT → DEF/HEAT → DEF each time turning the dial.
2	Fan speed control dial	Turn the dial to the right.	Fan speed switches OFF → AUTO → 1st → 2nd → 3rd → 4th → 5th → 6th → 7th each time the dial is turned.
3	FRESH/RECIRC switch	Press the FRESH/RECIRC switch.	Inlet opening switches RECIRC → FRESH → RECIRC each time pressing the switch. (LED illuminates at RECIRC)
		Keep the FRESH/RECIRC switch pressed for a while. (0.7 seconds or more)	The LED blinks twice and the system switches to AUTO.
4	A/C switch	Turn the A/C switch to ON with the fan speed control dial set to except for OFF position.	The LED lights and the compressor operates.
		Keep the FRESH/RECIRC switch pressed for a while. (0.7 seconds or more)	The LED blinks twice and the system switches to AUTO.
5	Auto function Operate in order starting from 1).	1) Set the following dial and switch to AUTO. • Air flow control dial • Fan speed control dial • FRESH/RECIRC switch • A/C switch 2) Turn the temperature control dial completely to the left, and set to the maximum cool position.	<ul style="list-style-type: none"> • Outlet air temperature: COOL • Fan speed: Max. • Outlet opening: VENT • Inlet opening: RECIRC • Compressor: AUTO
		3) Turn the temperature control dial to the right slowly up to the maximum hot position.	<ul style="list-style-type: none"> • Outlet air temperature: COOL → HOT • Fan speed: AUTO • Outlet opening: AUTO • Inlet opening: AUTO • Compressor: AUTO
		4) Turn the temperature control dial fully to the right, to the maximum hot position.	<ul style="list-style-type: none"> • Outlet air temperature: HOT • Fan speed: Max. • Outlet opening: HEAT • Inlet opening: FRESH • Compressor: AUTO
6	Defroster Interlock Function	Set the air flow control dial to the DEF or the DEF/HEAT position.	<ul style="list-style-type: none"> • Outlet air temperature: AUTO • Fan speed: AUTO • Outlet opening: DEF or DEF/HEAT • Inlet opening: FRESH • Compressor: ON
7	Rear defogger switch	Press the rear defogger switch.	LED illuminates.

2) Compressor operation inspection

No.	Point to check	Switch operation	Judgment standard
1	Compressor	1) Turn the A/C switch to ON. 2) Set the FAN switch between LO and HI.	Compressor: ON

3) Inspection of illumination control

No.	Point to check	Switch operation	Judgment standard
1	Illumination	Turn the lighting switch to ON.	Illumination becomes lit. If the LED is lit, the LED will dim.

Electrical Component Location

HVAC SYSTEM (AUTO A/C) (DIAGNOSTICS)

Brought to you by Eris Studios
NOT FOR SALE

3. Electrical Component Location

A: LOCATION

1. ENGINE COMPARTMENT

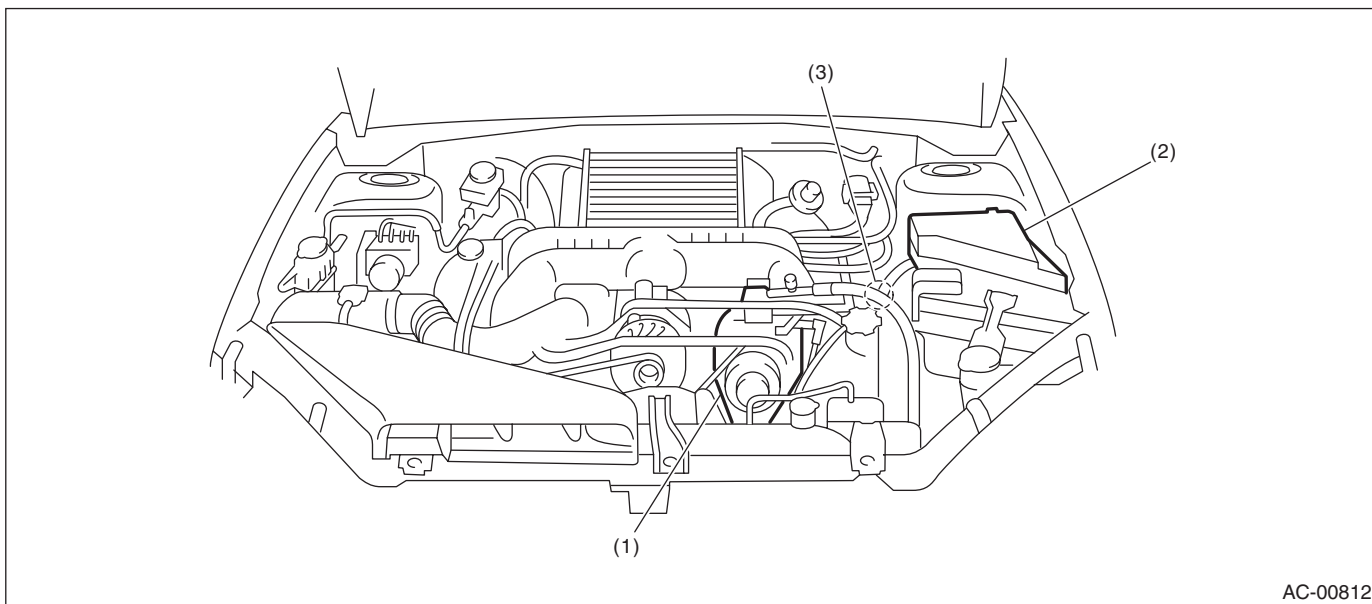

AC-00812

- (1) A/C compressor
- (2) A/C relay

- (3) Pressure switch

- (4) Ambient sensor

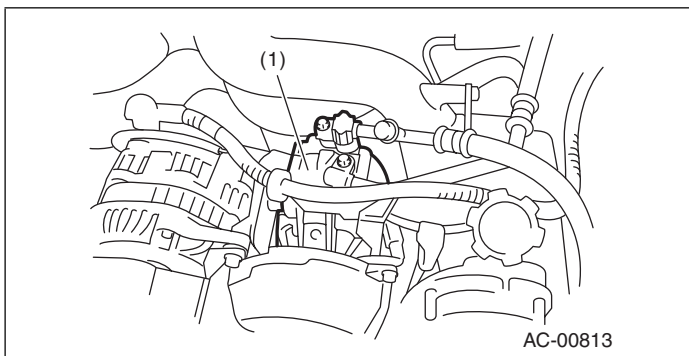

AC-00813

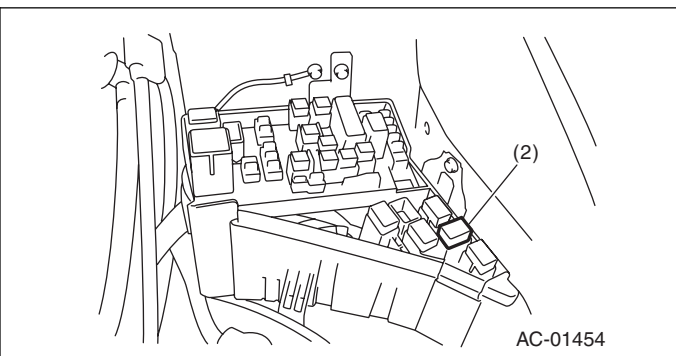

AC-01454

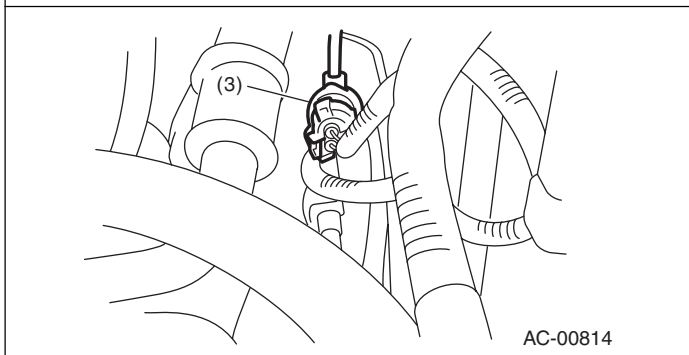

AC-00814

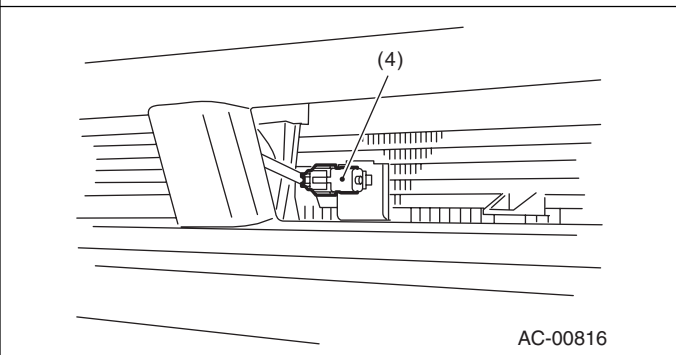

AC-00816

Electrical Component Location

HVAC SYSTEM (AUTO A/C) (DIAGNOSTICS)

Brought to you by Eris Studios
NOT FOR RESALE

2. COMPARTMENT

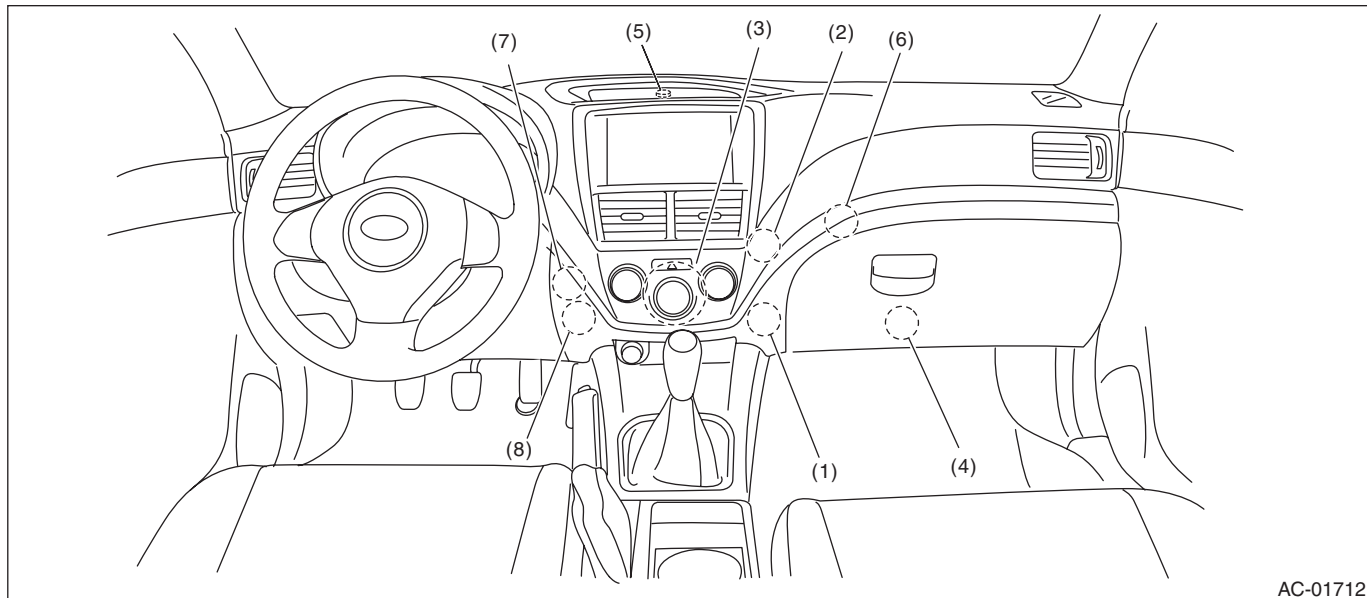

AC-01712

- | | | |
|-----------------------------|--------------------------|------------------------|
| (1) Evaporator sensor | (4) Blower motor | (7) Mode door actuator |
| (2) Air mix door actuator | (5) Sunload sensor | (8) In-vehicle sensor |
| (3) Auto A/C control module | (6) Intake door actuator | |

Auto A/C Control Module I/O Signal

HVAC SYSTEM (AUTO A/C) (DIAGNOSTICS)

Brought to you by Eris Studios
NOT FOR SALE

4. Auto A/C Control Module I/O Signal

A: ELECTRICAL SPECIFICATION

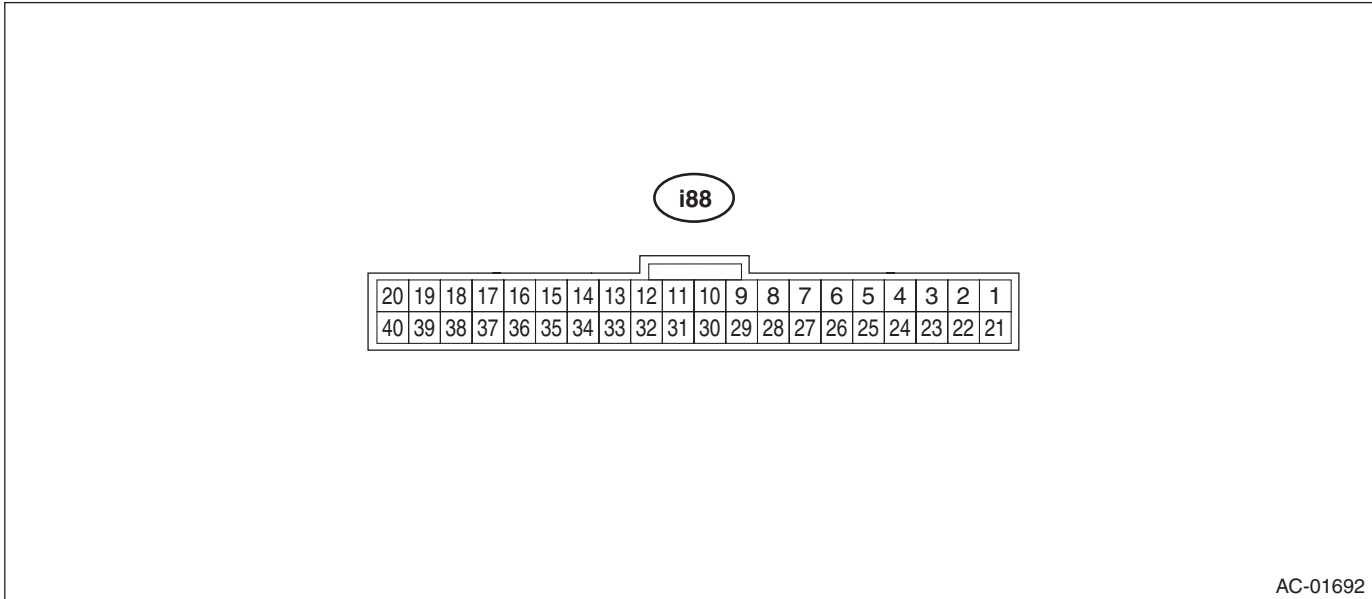

AC-01692

Auto A/C Control Module I/O Signal

HVAC SYSTEM (AUTO A/C) (DIAGNOSTICS)

Brought to you by Eris Studios
NOT FOR RESALE

Terminal No.	Contents	Measuring condition	Standard
1	Mode actuator #4	Actuator active	8 V or more
2	Mode actuator #3	Actuator active	8 V or more
3	Mode actuator #2	Actuator active	8 V or more
4	Mode actuator #1	Actuator active	8 V or more
6	Intake door actuator (FRESH air)	Fresh air condition	1 V or less
7	Intake door actuator (MIX)	MIX condition	1 V or less
8	Intake door actuator (RECIRCULATED air)	Recirculated air condition	1 V or less
9	Blower fan ON signal	When blower fan is turned to ON.	1 V or less
10	Rr defogger operation signal input	When Rr defogger is active	10 V or more
11	A/C cut signal	When A/C is cut	1 V or less
14	Sensor GND	Always	1 V or less
15	ACC power supply	ACC ON	Battery voltage
16	Sunload sensor	When exposed to sunlight	4.5 V
17	RECIRC sensor	Ignition switch ON	25°C: 1 — 5 V
18	After evaporator sensor	Changes according to the temperature after passing through the evaporator	1 — 4.5 V
19	CAN Lo	Unable to measure the voltage because of digital signal.	—
20	CAN Hi	Unable to measure the voltage because of digital signal.	—
25	Air mix actuator #4	Air mix actuator active	8 V or more
26	Air mix actuator #3	Air mix actuator active	8 V or more
27	Air mix actuator #2	Air mix actuator active	8 V or more
28	Air mix actuator #1	Air mix actuator active	8 V or more
31	BATT	Always	Battery voltage
32	IGN	Ignition ON	Battery voltage
34	GND	Always	1 V or less
36	A/C ON signal	When A/C is active	8 V or more
35	ILL-	Illumination ON (measure between 37 — 35)	Battery voltage
37	ILL+		
39	Rr defogger switch output	When rear defogger relay is ON	Battery voltage
40	Fan control signal	Ignition switch ON, Blower switch ON	8 V or more

B: WIRING DIAGRAM

1. AIR CONDITIONER AUTO A/C MODEL

<Ref. to WI-141, WIRING DIAGRAM, Air Conditioning System.>

Diagnostic Chart for Self-diagnosis

HVAC SYSTEM (AUTO A/C) (DIAGNOSTICS)

Brought to you by Eris Studios
NOT FOR SALE

5. Diagnostic Chart for Self-diagnosis

A: OPERATION

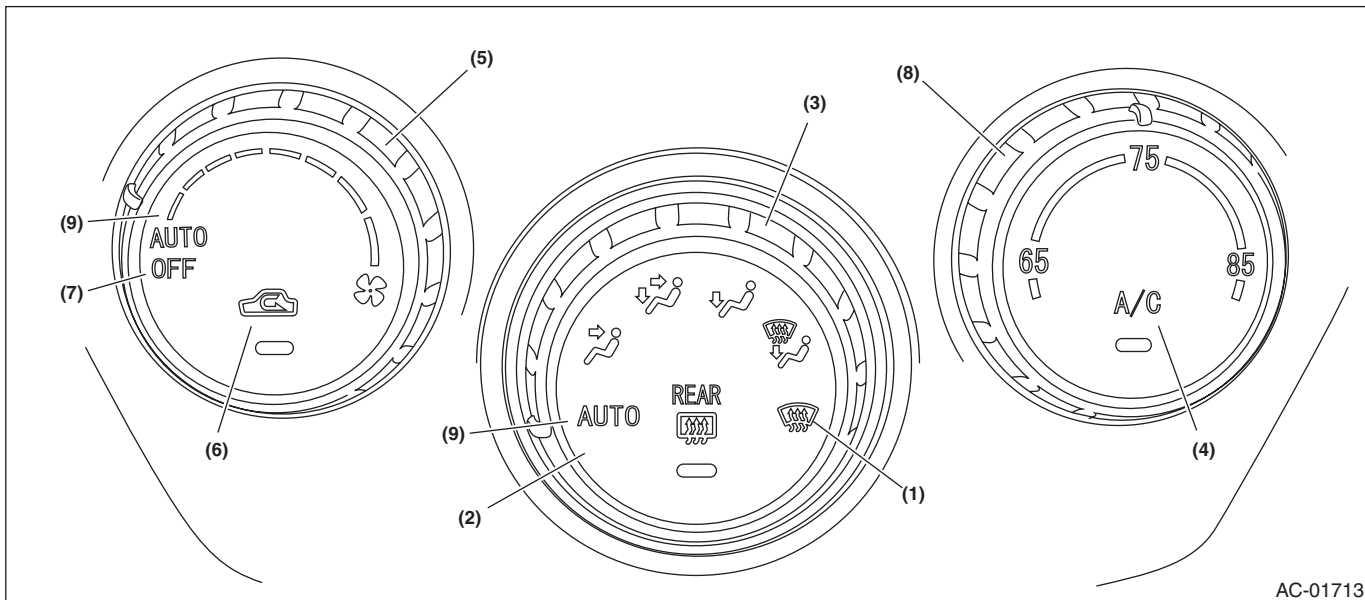

AC-01713

- (1) Defroster switch
- (2) Rear window defogger switch
- (3) Air flow control dial
- (4) A/C switch
- (5) Fan speed control dial
- (6) FRESH/RECIRC switch
- (7) OFF switch
- (8) Temperature adjustment dial
- (9) AUTO switch

1. A/C CONTROL PANEL SELF-DIAGNOSIS

Step	Check	Yes	No
1 SELECT SELF-DIAGNOSIS MODE IN THE CONTROL PANEL. 1) Set the air flow control dial and fan speed control dial to the AUTO position. 2) Start the engine with the A/C switch and the FRESH/RECIRC switch pressed.	Does the self-diagnosis mode operate?	Go to step 2.	<Ref. to AC(diag)-13, A/C OR SELF DIAGNOSIS FUNCTION FAILS TO OPERATE, Diagnostics for A/C System Malfunction.>
2 CHECK THE LIGHTING OF THE LED. Make sure that all switch LEDs on the control panel illuminate.	Do all LEDs blink eight times?	Go to step 3.	Replace the control panel.
3 CHECK SENSOR MALFUNCTION. 1) Set the air flow control dial and fan speed control dial to the AUTO position. 2) If the system has trouble for each sensor, the FRESH/RECIRC switch LED blinks or turns off. 3) If the system has no trouble, the FRESH/RECIRC switch LED illuminates.	Does the FRESH/RECIRC switch LED illuminate?	Go to step 5.	Go to step 4.
4 CONFIRM MALFUNCTIONING SENSOR. 1) Set the air flow control dial to the AUTO position. 2) Turn the fan speed control dial to each mode position, and check each switch LED illumination according to the sensor check table. <Ref. to AC(diag)-11, SENSOR CHECK TABLE, OPERATION, Diagnostic Chart for Self-diagnosis.>	When the fan speed control dial is set to the individual mode positions, does the FRESH/RECIRC switch LED turn off?	Go to step 5.	Repair the defective sensor. <Ref. to AC(diag)-29, Diagnostic Procedure for Sensors.>

Diagnostic Chart for Self-diagnosis

HVAC SYSTEM (AUTO A/C) (DIAGNOSTICS)

Brought to you by Eris Studios
NOT FOR RESALE

Step	Check	Yes	No
5 CHECK AIR MIX DOOR AND MODE DOOR POSITION SIGNALS. 1) Set the air flow control dial to the FACE position. 2) Turn the fan speed control dial to AUTO. 3) If the system has trouble for air mix door signal and mode door position signal, the FRESH/RECIRC switch LED is turned off or blinks. 4) If the system has no trouble, the FRESH/RECIRC switch LED illuminates.	Does the FRESH/RECIRC switch LED illuminate?	Go to step 6.	Check the mode door actuator circuit. <Ref. to AC(diag)-25, MODE DOOR ACTUATOR, Diagnostic Procedure for Actuators.>
6 CHECK AIR MIX DOOR AND MODE DOOR POSITION DRIVE SIGNALS. 1) Set the air flow control dial to the FACE position. 2) Set the fan speed control dial to each position, and check the lighting conditions of each LED. <Ref. to AC(diag)-9, A/C CONTROL PANEL SELF-DIAGNOSIS, OPERATION, Diagnostic Chart for Self-diagnosis.>	Does the lighting conditions of the LED match the drive signal list?	Go to step 7.	Check the air mix door actuator circuit. <Ref. to AC(diag)-27, AIR MIX DOOR ACTUATOR, Diagnostic Procedure for Actuators.>
7 CHECK AIR MIX DOOR AND MODE DOOR POSITION DRIVE SIGNALS. 1) Press the A/C switch. 2) Set the fan speed control dial to each position, and check the lighting conditions of each LED. <Ref. to AC(diag)-9, A/C CONTROL PANEL SELF-DIAGNOSIS, OPERATION, Diagnostic Chart for Self-diagnosis.>	Does the lighting conditions of the LED match the drive signal list?	Go to step 8.	Check the mode door actuator circuit. <Ref. to AC(diag)-25, MODE DOOR ACTUATOR, Diagnostic Procedure for Actuators.>
8 CHECK OPERATION OF EACH ACTUATOR, BLOWER FAN AND COMPRESSOR CLUTCH. 1) Set the air flow control dial to the B/L position. 2) Set the fan speed control dial to AUTO — 7th position, and select the operating mode. 3) Check the operation of each mode according to operating mode table. <Ref. to AC(diag)-9, A/C CONTROL PANEL SELF-DIAGNOSIS, OPERATION, Diagnostic Chart for Self-diagnosis.> <ul style="list-style-type: none"> • FRESH/RECIRC door • Air flow control door • Air mix door • Blower fan • A/C compressor 	Does the operation of each mode match to operating mode table?	Turn the fan speed control dial to OFF or turn the ignition switch to OFF, to complete the self diagnosis.	Repair the malfunctioning part in accordance with each diagnostic chart.

Diagnostic Chart for Self-diagnosis

HVAC SYSTEM (AUTO A/C) (DIAGNOSTICS)

Brought to you by Eris Studios
NOT FOR SALE

2. SENSOR CHECK TABLE

NOTE:

When the sunload sensor check is performed indoors or in the shade, it could be diagnosed as having an open circuit. Always check the sunload sensor at a location exposed to direct sunlight.

Air flow control dial position	Fan dial position	Sensor	No trouble	Short circuit	Open circuit	When currently malfunctioning	When having malfunctioned in the past
AUTO	AUTO	In-vehicle sensor	FRESH/RECIRC switch LED is turned off	FRESH/RECIRC switch LED blinks (Illuminates for 0.2 sec. ⇔ turns off for 0.2 sec.)	FRESH/RECIRC switch LED blinks (Illuminates for 1 sec. ⇔ turns off for 1 sec.)	Rear window defogger switch LED is turned off	Rear window defogger switch LED illuminates
	1st	Ambient sensor		FRESH/RECIRC switch LED blinks (Illuminates for 0.2 sec. ⇔ turns off for 0.2 sec.)			
	2nd	Evaporator sensor		FRESH/RECIRC switch LED blinks (Illuminates for 0.2 sec. ⇔ turns off for 0.2 sec.)			
	3rd	Engine coolant temperature sensor		—			
	4th	Sunload sensor		FRESH/RECIRC switch LED blinks (Illuminates for 0.2 sec. ⇔ turns off for 0.2 sec.)			
	5th – 7th	CAN communication		—			

3. OPERATING MODE TABLE

Operation	Fan speed control dial position							
	AUTO	1st	2nd	3rd	4th	5th	6th	7th
Blower fan	4 V	4 V	4.9 V	5.9 V	7.0 V	8.3 V	9.8 V	14 V
FRESH/RECIRC door	RECIRC	RECIRC	MIX	FRESH	FRESH	FRESH	FRESH	FRESH
Air flow control door	FACE	FACE	FACE	B/L	HEAT	HEAT	D/H	D/H
Air mix door	0%	0%	0%	50%	50%	100%	100%	100%
A/C compressor	OFF	ON	ON	ON	ON	ON	ON	ON

Diagnostic Chart for Self-diagnosis

HVAC SYSTEM (AUTO A/C) (DIAGNOSTICS)

Brought to you by Eris Studios
NOT FOR RESALE

4. DRIVE PROGRESS CHECK TABLE

Air flow control dial position	Fan speed control dial position	Drive signal to check	A/C switch LED	No trouble	Short circuit	Open circuit	When currently malfunctioning	When having malfunctioned in the past
FACE	AUTO	MIX #1	Blinking (Illuminates for 0.2 sec. ⇔ turns off for 0.2 sec.)	FRESH/ RECIRC switch LED is turned off	FRESH/ RECIRC switch LED blinks (Illuminates for 0.2 sec. ⇔ turns off for 0.2 sec.)	FRESH/ RECIRC switch LED blinks (Illuminates for 1 sec. ⇔ turns off for 1 sec.)	Rear window defogger switch LED is turned off	Rear window defogger switch LED illuminates
	1st	MIX #2						
	2nd	MIX #3						
	3rd — 7th	MIX #4						
	AUTO	MODE #1	Blinking (Illuminates for 1 sec. ⇔ turns off for 1 sec.)					
	1st	MODE #2						
	2nd	MODE #3						
	3rd — 7th	MODE #4						

Diagnostics for A/C System Malfunction

HVAC SYSTEM (AUTO A/C) (DIAGNOSTICS)

Brought to you by Eriss Studios
NOT FOR SALE

6. Diagnostics for A/C System Malfunction

A: A/C OR SELF DIAGNOSIS FUNCTION FAILS TO OPERATE

TROUBLE SYMPTOM:

- Set temperature is not indicated on the display, switch LEDs are faulty and switches do not operate.
- Self-diagnosis system does not operate.

WIRING DIAGRAM:

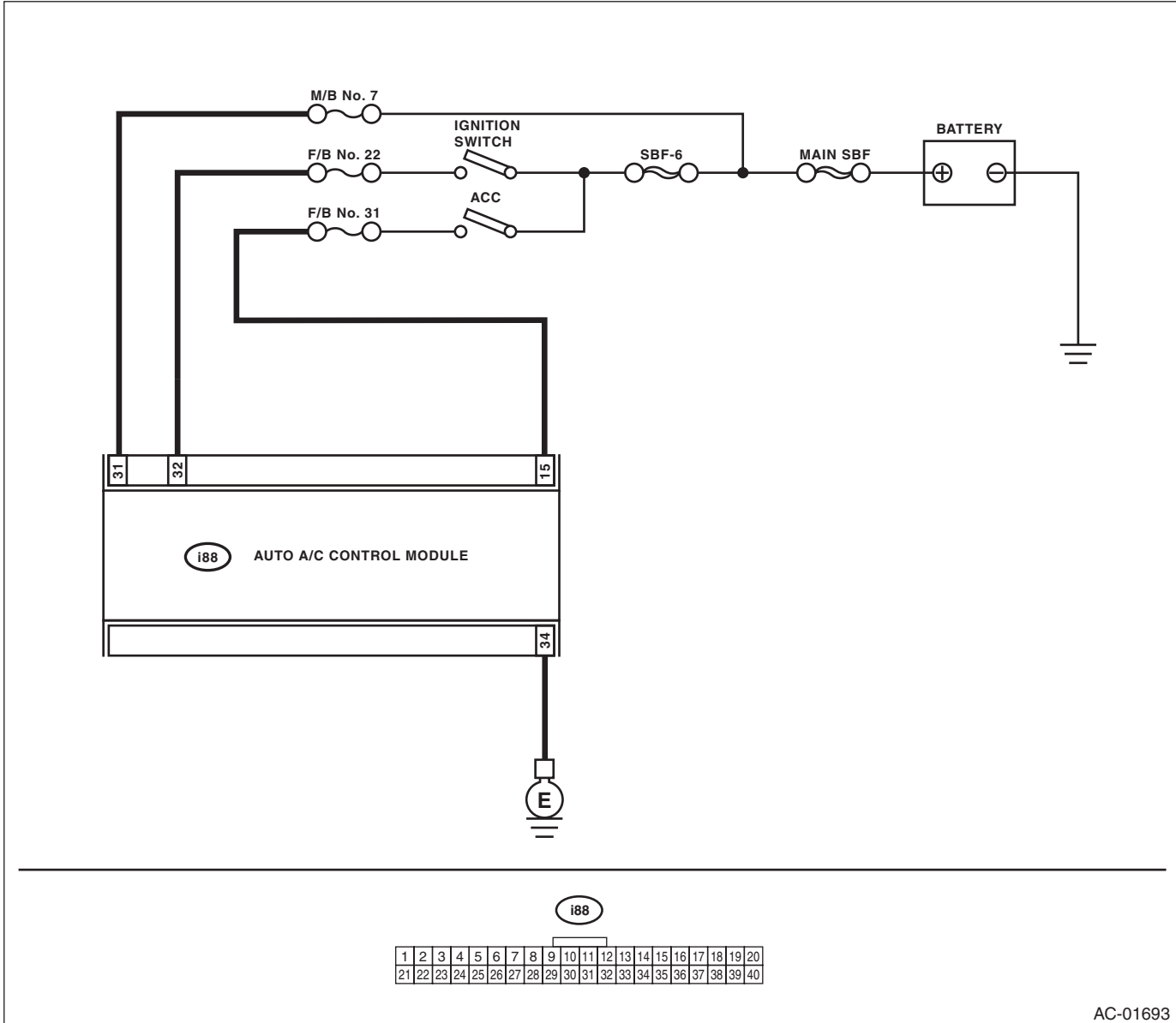

AC-01693

Diagnostics for A/C System Malfunction

HVAC SYSTEM (AUTO A/C) (DIAGNOSTICS)

Brought to you by Eris Studios
NOT FOR RESALE

	Step	Check	Yes	No
1	CHECK FUSE. 1) Turn the ignition switch to OFF. 2) Remove the fuse No. 7 from main fuse box. 3) Check the condition of fuse.	Is the fuse blown out?	Replace the fuse.	Go to step 2.
2	CHECK FUSE. 1) Turn the ignition switch to OFF. 2) Remove the fuse No. 22 and No. 31 from fuse & relay box. 3) Check the condition of fuse.	Is the fuse blown out?	Replace the fuse.	Go to step 3.
3	CHECK A/C CONTROL MODULE POWER CIRCUIT. 1) Remove the A/C control panel. 2) Disconnect the A/C control panel harness connector. 3) Measure the voltage between A/C control panel harness connector terminal and chassis ground after turning the ignition switch to ACC. Connector & terminal (i88) No. 15 (+) — Chassis ground (-):	Is the voltage 10 V or more?	Go to step 4.	Check for open or short circuit in the harness between A/C control panel and fuse.
4	CHECK A/C CONTROL MODULE POWER CIRCUIT. Measure the voltage between A/C control panel harness connector terminal and chassis ground after turning the ignition switch to ON. Connector & terminal (i88) No. 32 (+) — Chassis ground (-):	Is the voltage 10 V or more?	Go to step 5.	Check for open or short circuit in the harness between A/C control panel and fuse.
5	CHECK A/C CONTROL PANEL GROUND POWER CIRCUIT. Measure the resistance of harness between A/C control panel and chassis ground after turning the ignition switch to OFF. Connector & terminal (i88) No. 34 — Chassis ground:	Is resistance less than 10 Ω ?	Go to step 6.	Repair the harness for ground line.
6	CHECK POOR CONTACT. Check poor contact of auto A/C control module connector.	Is there poor contact in connector?	Repair the connector.	Replace the auto A/C control module.

Diagnostics for A/C System Malfunction

HVAC SYSTEM (AUTO A/C) (DIAGNOSTICS)

Brought to you by Eris Studios
NOT FOR SALE

B: BLOWER FAN DOES NOT ROTATE

TROUBLE SYMPTOM:

- Blower motor does not rotate.
- Blower motor does not change speeds.

WIRING DIAGRAM:

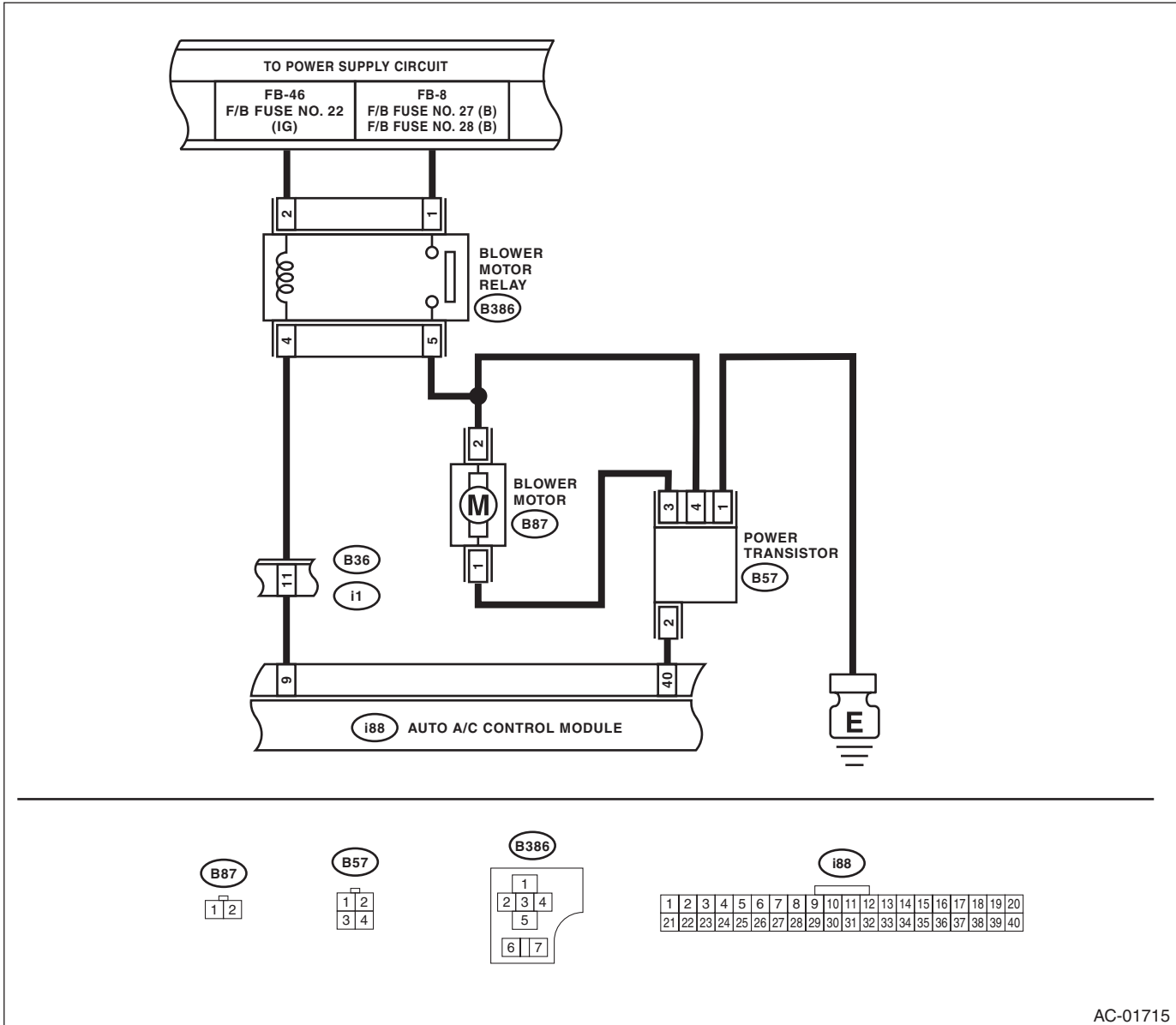

AC-01715

Diagnostics for A/C System Malfunction

HVAC SYSTEM (AUTO A/C) (DIAGNOSTICS)

Brought to you by Eris Studios
NOT FOR RESALE

Step	Check	Yes	No
1 CHECK FUSE. 1) Remove fuse No. 22, 27 and 28 from the fuse & relay box. 2) Check the condition of fuse.	Is any fuse blown out?	Replace the fuse.	Go to step 2.
2 CHECK BLOWER MOTOR RELAY POWER SUPPLY. 1) Turn the ignition switch to OFF. 2) Remove the blower motor relay. 3) Turn the ignition switch to ON. 4) Use a tester to measure the voltage between the blower motor relay connector and chassis ground. Connector & terminal (B87) No. 2 — Chassis ground:	Is the voltage 10 V or more?	Go to step 3.	Repair the open circuit of blower motor power supply line harness.
3 CHECK BLOWER MOTOR RELAY POWER SUPPLY. 1) Turn the ignition switch to ON. 2) Turn the blower switch to ON. 3) Use a tester to measure the voltage between the blower motor relay connectors. Connector & terminal (B386) No. 2 — No. 4:	Is the voltage 10 V or more?	Go to step 5.	Go to step 4.
4 CHECK HARNESS. 1) Turn the ignition switch to OFF. 2) Disconnect the auto A/C control module connector (i88). 3) Use a tester to measure the resistance between harness terminals. Connector & terminal (B386) No. 4 — (i88) No. 9:	Is the resistance less than 10 Ω ?	Go to step 5.	Repair or replace the open circuit of the harness.
5 CHECK BLOWER MOTOR RELAY. 1) Turn the ignition switch to OFF. 2) Remove the blower motor relay. 3) Connect the battery terminal to the blower motor relay. No. 2 — No. 4: 4) Measure the resistance between terminals. Terminals No. 1 — No. 5:	Is resistance less than 1 Ω ?	Go to step 6.	Replace the blower motor relay.
6 CHECK BLOWER MOTOR POWER SUPPLY. 1) Turn the ignition switch to OFF. 2) Install the blower motor relay. 3) Disconnect the blower motor connector. 4) Turn the ignition switch to ON. 5) Turn the blower switch to ON. 6) Use a tester to measure the voltage between the blower motor connector and chassis ground. Connector & terminal (B87) No. 2 — Chassis ground:	Is the voltage 10 V or more?	Go to step 7.	Repair or replace the harness between the blower motor relay and the blower motor.
7 CHECK BLOWER MOTOR. 1) Disconnect the connector from the blower motor. 2) Connect the battery positive terminal to terminal No. 2 of blower motor connector, and negative terminal to terminal No. 1. 3) Make sure the blower motor runs.	Does the blower motor run?	Go to step 8.	Replace the blower motor.

Diagnostics for A/C System Malfunction

HVAC SYSTEM (AUTO A/C) (DIAGNOSTICS)

Brought to you by Eriss Studios
NOT FOR SALE

	Step	Check	Yes	No
8	<p>CHECK HARNESS.</p> <ol style="list-style-type: none"> 1) Turn the ignition switch to OFF. 2) Disconnect the power transistor connector. 3) Disconnect the auto A/C control module connector. 4) Use a tester to measure the resistance between harness terminals. <p>Connector & terminal (B57) No. 1 — Chassis ground: (B57) No. 2 — (i88) No. 40: (B57) No. 3 — (B87) No. 1: (B57) No. 4 — (B87) No. 2: (B57) No. 4 — (B386) No. 5:</p>	Is the resistance less than 10 Ω?	Go to step 9.	Repair or replace the harness.
9	<p>CHECK FAN CONTROL SIGNAL.</p> <ol style="list-style-type: none"> 1) Turn the ignition switch to OFF. 2) Connect the blower motor and auto A/C control module. 3) Turn the ignition switch to ON. 4) Set the fan dial to 1st — 7th. 5) Use a tester to measure the voltage between the power transistor connector and chassis ground. 	Is approx. 10 V detected in 1st, and 1 V at 7th?	Replace the power transistor. <Ref. to AC-26, REMOVAL, Power Transistor (Auto A/C Model).>	Go to step 10.
10	<p>CHECK POOR CONTACT.</p> <p>Check poor contact of auto A/C control module connector.</p>	Is there poor contact in connector?	Repair the connector.	Replace the auto A/C control module.

Diagnostics for A/C System Malfunction

HVAC SYSTEM (AUTO A/C) (DIAGNOSTICS)

Brought to you by Eris Studios
NOT FOR RESALE

C: BLOWER MOTOR TURNS AROUND EARLY

TROUBLE SYMPTOM:

- The blower turns even though the blower switch is not turned ON.
- The blower motor continues to turn at high speed. (Cannot be adjusted.)

WIRING DIAGRAM:

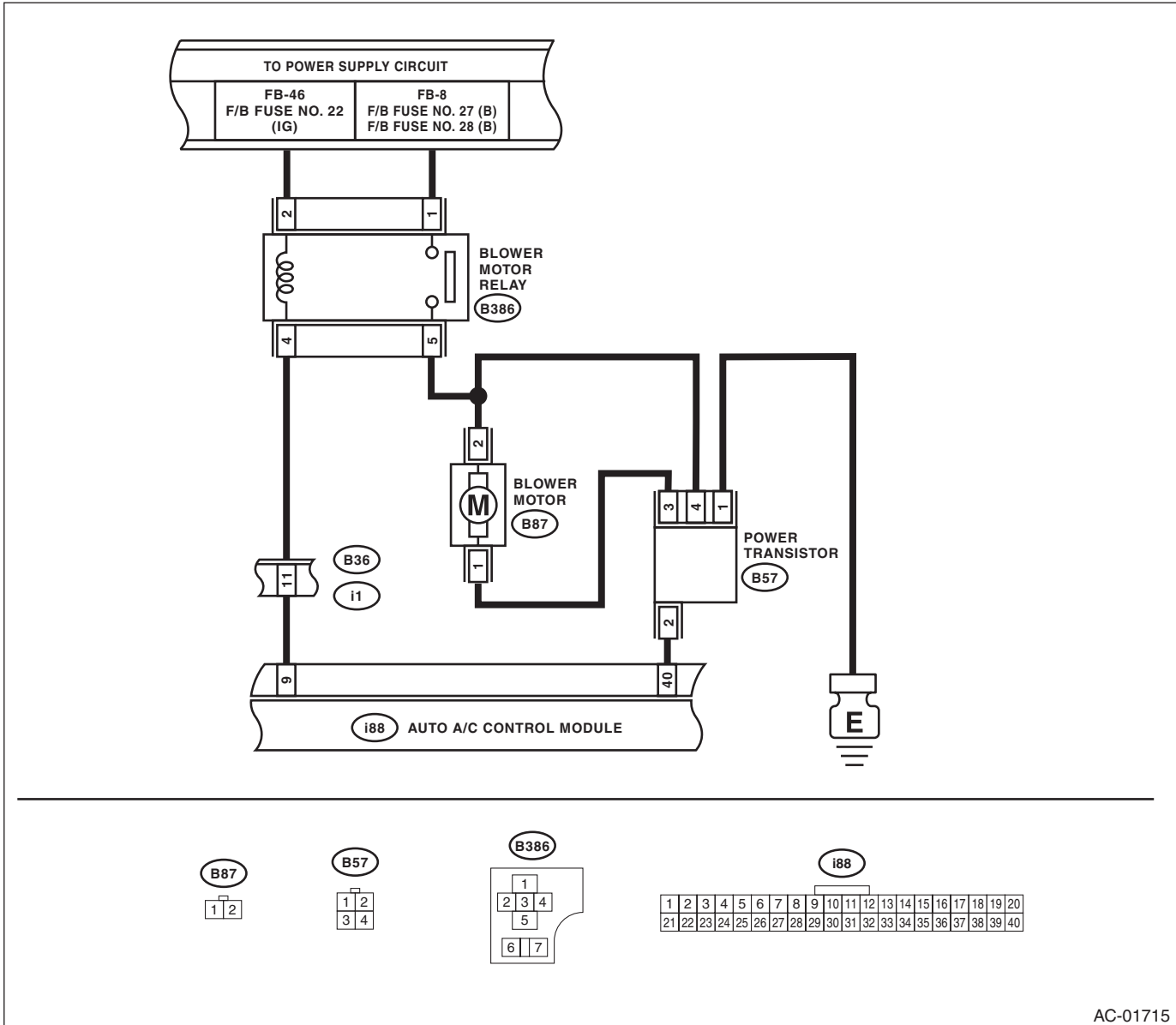

AC-01715

Diagnostics for A/C System Malfunction

HVAC SYSTEM (AUTO A/C) (DIAGNOSTICS)

Brought to you by Eriss Studios
NOT FOR RESALE

Step	Check	Yes	No
1 CHECK BLOWER MOTOR CIRCUIT. 1) Turn the ignition switch to OFF. 2) Disconnect the power transistor connector. 3) Use a tester to measure the resistance between the connector and chassis ground. Connector & terminal (B57) No. 3 — Chassis ground:	Is the resistance 10 Ω or more?	Go to step 2.	Repair or replace the harness.
2 CHECK POWER TRANSISTOR. Measure the resistance between power transistor terminals with a tester. Connector & terminal (B57) No. 3 — No. 1:	Is resistance less than 10 Ω?	Replace the power transistor. <Ref. to AC-26, REMOVAL, Power Transistor (Auto A/C Model).>	Go to step 3.
3 CHECK HARNESS. 1) Remove the auto A/C control module. 2) Use a tester to measure the resistance between the power transistor connector and chassis ground. Connector & terminal (B57) No. 2 — Chassis ground:	Is resistance less than 10 Ω?	Repair or replace the short circuit of the harness.	Replace the auto A/C control module.

Diagnostics for A/C System Malfunction

Brought to you by Eris Studios
NOT FOR RESALE

HVAC SYSTEM (AUTO A/C) (DIAGNOSTICS)

D: COMPARTMENT TEMPERATURE DOES NOT CHANGE, OR A/C SYSTEM DOES NOT RESPOND PROMPTLY

TROUBLE SYMPTOM:

- Compartment temperature does not change (Cold air does not come out).
- The A/C system does not respond (Response is extremely slow).

WIRING DIAGRAM:

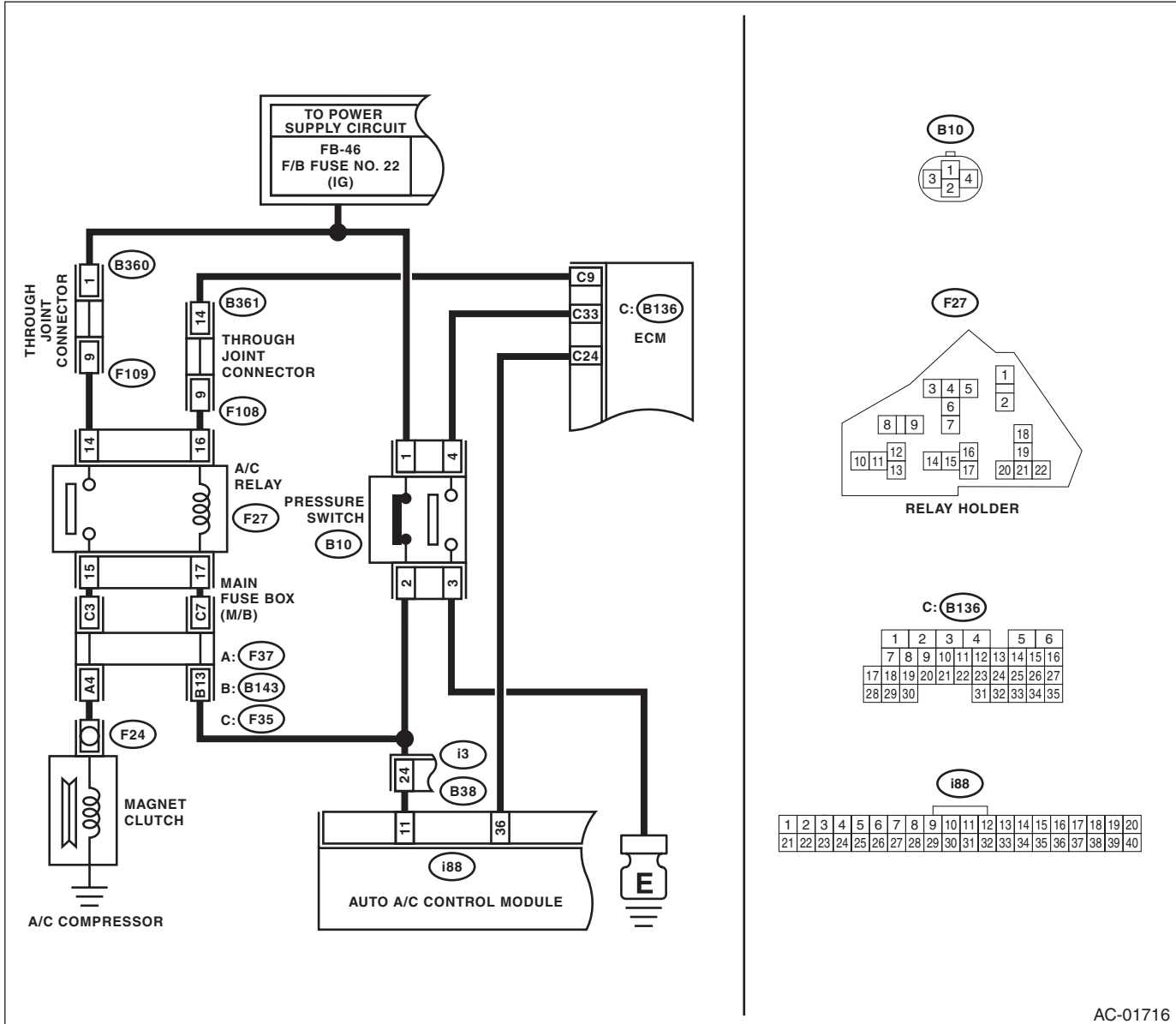

AC-01716

Diagnostics for A/C System Malfunction

HVAC SYSTEM (AUTO A/C) (DIAGNOSTICS)

Brought to you by Eris Studios
NOT FOR RESALE

Step	Check	Yes	No
1 CHECK FUSE. 1) Turn the ignition switch to OFF. 2) Remove the fuse No. 22 from fuse & relay box. 3) Check the condition of fuse.	Is the fuse blown out?	Replace the fuse.	Go to step 2.
2 CHECK SIGNAL TO A/C RELAY AND AUTO A/C CONTROL MODULE. 1) Disconnect the A/C relay and auto A/C control module harness connector. 2) Turn the ignition switch to ON. 3) Measure the voltage between A/C relay connector terminal and chassis ground. 4) Measure the voltage between auto A/C control module harness connector terminal and chassis ground. Connector & terminal <i>(F27) No. 17 (+) — Chassis ground (-):</i> <i>(i88) No. 11 (+) — Chassis ground (-):</i>	Is the voltage 10 V or more?	Go to step 5.	Go to step 3.
3 CHECK POWER SUPPLY FOR PRESSURE SWITCH. 1) Turn the ignition switch to OFF. 2) Disconnect the pressure switch harness connector. 3) Turn the ignition switch to ON. 4) Measure the voltage between pressure switch harness connector terminal and chassis ground. Connector & terminal <i>(B10) No. 2 (+) — Chassis ground (-):</i>	Is the voltage 10 V or more?	Go to step 4.	Check for open or short circuit in the harness between fuse and pressure switch.
4 CHECK HARNESS BETWEEN PRESSURE SWITCH AND A/C RELAY, AUTO A/C CONTROL MODULE. 1) Turn the ignition switch to OFF. 2) Measure the resistance of harness between pressure switch connector and A/C relay connector. 3) Measure the resistance of harness between pressure switch connector and auto A/C control module connector. Connector & terminal <i>(B10) No. 2 — (F27) No. 17:</i> <i>(B10) No. 2 — (i88) No. 11:</i>	Is resistance less than 1 Ω ?	Check the pressure switch. <Ref. to AC-37, INSPECTION, Pressure Switch (Triple Pressure Switch).>	Repair the harness.
5 CHECK POWER SUPPLY FOR A/C RELAY. Measure the voltage between A/C relay connector terminal and chassis ground. Connector & terminal <i>(F27) No. 14 (+) — Chassis ground (-):</i>	Is the voltage 10 V or more?	Go to step 6.	Check open or short circuit of harness between fuse and A/C relay.
6 CHECK A/C RELAY. Check the A/C relay. <Ref. to AC-36, INSPECTION, Relay and Fuse.>	Is there a malfunction in the A/C relay?	Go to step 7.	Replace the A/C relay.

Diagnostics for A/C System Malfunction

HVAC SYSTEM (AUTO A/C) (DIAGNOSTICS)

Brought to you by Eris Studios
NOT FOR RESALE

Step	Check	Yes	No
7 CHECK A/C ON SIGNAL. 1) Turn the ignition switch to OFF. 2) Connect the A/C relay and all disconnected connectors. 3) Start the engine and turn the A/C switch to ON. 4) Turn the temperature control dial at maximum cool position. 5) Measure the voltage between auto A/C control module harness connector terminal and chassis ground. Connector & terminal (i88) No. 36 (+) — Chassis ground (-):	Is the voltage 5.5 V or more?	Go to step 9.	Go to step 8.
8 CHECK HARNESS BETWEEN AUTO A/C CONTROL MODULE AND ECM. 1) Turn the ignition switch to OFF. 2) Disconnect the harness connector of auto A/C control module and ECM. 3) Measure the resistance of harness between auto A/C control module connector and ECM connector. Connector & terminal (i88) No. 36 — (B136) No. 24:	Is resistance less than 1 Ω ?	Replace the auto A/C control module.	Repair the harness.
9 CHECK MAGNET CLUTCH ON SIGNAL. 1) Stop the engine and turn the A/C switch to OFF. 2) Turn the ignition switch to ON. 3) Measure the voltage between ECM connector terminal and chassis ground. Connector & terminal (B136) No. 9 (+) — Chassis ground (-):	Is the voltage 10 V or more?	Go to step 10.	Check for open or short circuit in the harness between A/C relay and ECM.
10 CHECK MAGNET CLUTCH ON SIGNAL. 1) Start the engine and turn the A/C switch to ON. 2) Turn the temperature control dial at maximum cool position. 3) Measure the voltage between ECM connector terminal and chassis ground. Connector & terminal (B136) No. 9 (+) — Chassis ground (-):	Is the voltage 0 V?	Go to step 11.	Replace the ECM.
11 CHECK POWER SUPPLY FOR MAGNET CLUTCH. 1) Stop the engine and turn the A/C switch to OFF. 2) Disconnect the harness connector of magnet clutch. 3) Start the engine and turn the A/C switch to ON. 4) Turn the temperature control dial at maximum cool position. 5) Measure the voltage between magnet clutch harness connector terminal and chassis ground. Connector & terminal (F24) No. 1 (+) — Chassis ground (-):	Is the voltage 10 V or more?	Inspect the compressor. <Ref. to AC-31, INSPECTION, Compressor.>	Check for open or short circuit in the harness between A/C relay and magnet clutch.

Diagnostic Procedure for Actuators

HVAC SYSTEM (AUTO A/C) (DIAGNOSTICS)

Brought to you by Eris Studios
NOT FOR SALE

7. Diagnostic Procedure for Actuators

A: INTAKE DOOR ACTUATOR

TROUBLE SYMPTOM:

FRESH/RECIRC mode is not changed.

WIRING DIAGRAM:

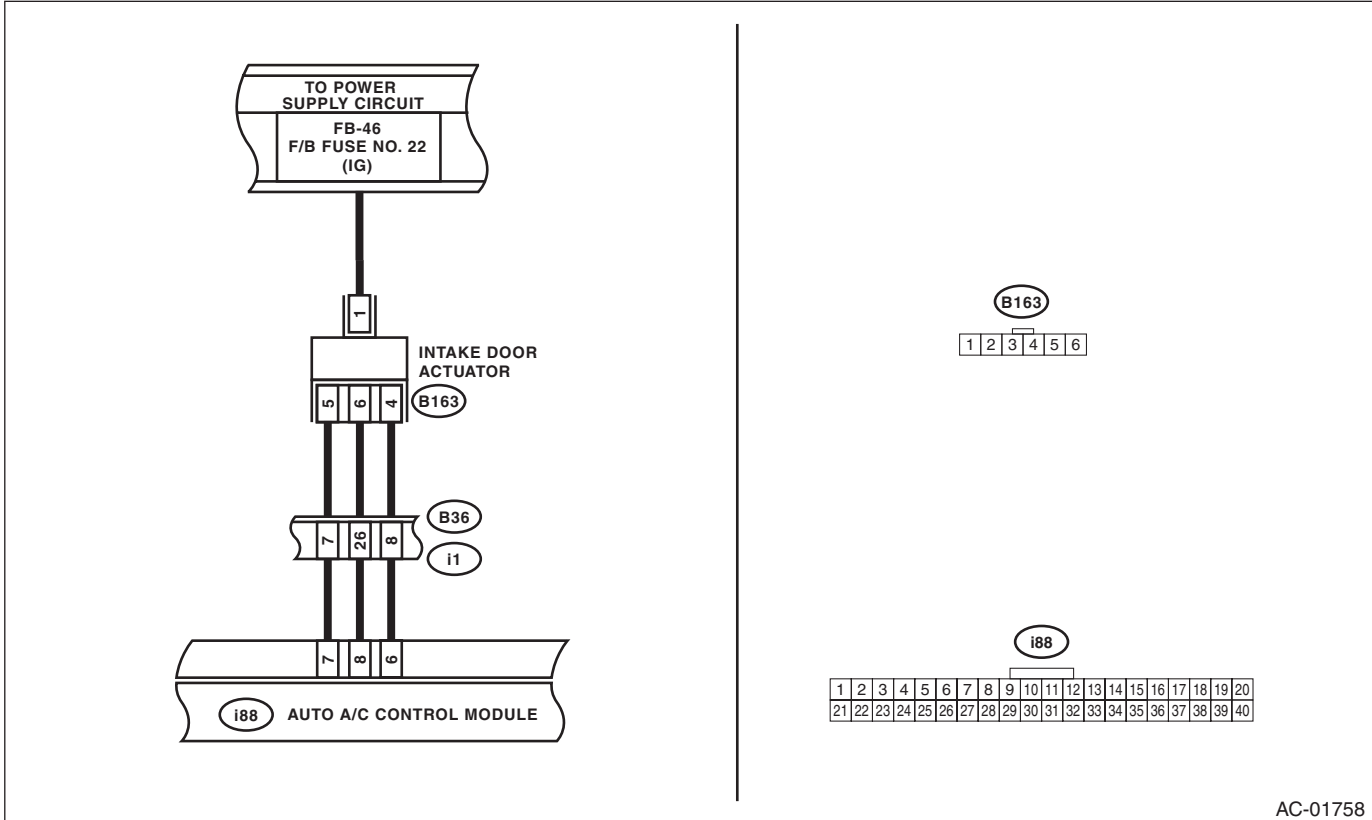

AC-01758

Diagnostic Procedure for Actuators

HVAC SYSTEM (AUTO A/C) (DIAGNOSTICS)

Brought to you by Eris Studios
NOT FOR RESALE

Step	Check	Yes	No
1 CHECK POWER SUPPLY FOR INTAKE DOOR ACTUATOR. 1) Turn the ignition switch to OFF. 2) Disconnect the intake door actuator connector. 3) Turn the ignition switch to ON. 4) Measure the voltage between intake door actuator connector and chassis ground. Connector & terminal (B163) No. 1 (+) — Chassis ground (-):	Is the voltage 7 V (at normal temperature) ?	Go to step 2.	Check for open or short circuit in the harness between intake door actuator and fuse.
2 CHECK HARNESS BETWEEN AUTO A/C CONTROL MODULE AND INTAKE DOOR ACTUATOR. 1) Turn the ignition switch to OFF. 2) Disconnect the auto A/C control module connector. 3) Measure the resistance between intake door actuator connector and auto A/C control module connector. Connector & terminal (i88) No. 8 — (B163) No. 6: (i88) No. 7 — (B163) No. 5: (i88) No. 6 — (B163) No. 4:	Is resistance less than 1 Ω?	Go to step 3.	Repair the harness between auto A/C control module and intake door actuator.
3 CHECK OPERATION OF INTAKE DOOR ACTUATOR. 1) Connect the intake door actuator connector. 2) Ground the auto A/C control module connector with a suitable wire. 3) Turn the ignition switch to ON, and check the operation of intake door actuator. Connector & terminal (B163) No. 4 — Chassis ground:	Does the actuator move to the FRESH side?	Go to step 4.	Replace the intake door actuator.
4 CHECK OPERATION OF INTAKE DOOR ACTUATOR. 1) Turn the ignition switch to OFF. 2) Ground the auto A/C control module connector with a suitable wire. 3) Turn the ignition switch to ON, and check the operation of intake door actuator. Connector & terminal: (B163) No. 5 — Chassis ground:	Does the actuator move to the RECIRC side?	Replace the auto A/C control module.	Replace the intake door actuator.

Diagnostic Procedure for Actuators

HVAC SYSTEM (AUTO A/C) (DIAGNOSTICS)

Brought to you by Eris Studios
NOT FOR SALE

B: MODE DOOR ACTUATOR

TROUBLE SYMPTOM:

Air flow outlet is not changed.

WIRING DIAGRAM:

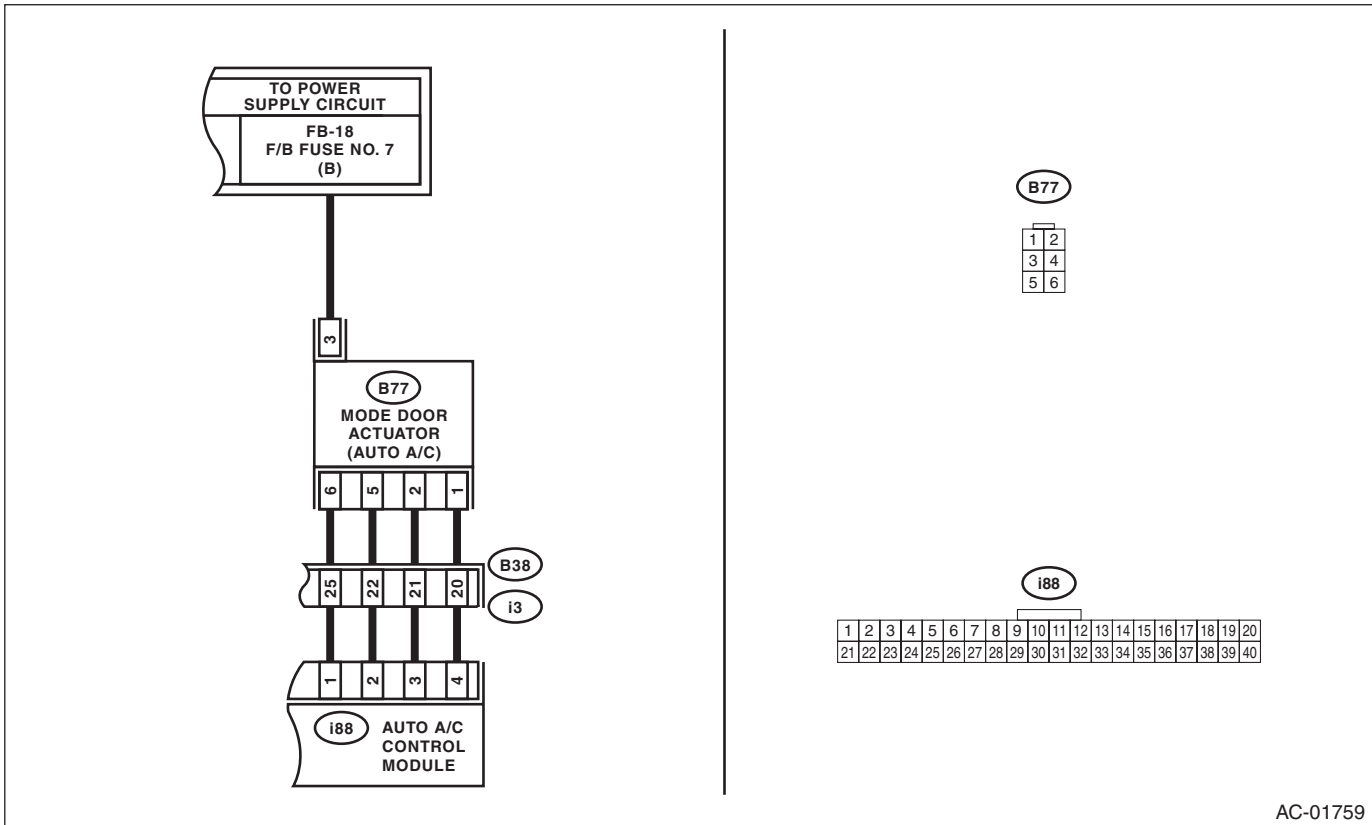

AC-01759

Diagnostic Procedure for Actuators

HVAC SYSTEM (AUTO A/C) (DIAGNOSTICS)

Brought to you by Eris Studios
NOT FOR RESALE

Step	Check	Yes	No
1 CHECK POWER SUPPLY FOR MODE DOOR ACTUATOR. 1) Turn the ignition switch to OFF. 2) Disconnect the mode door actuator connector. 3) Turn the ignition switch to ON. 4) Measure the voltage between the mode door actuator connector terminal and chassis ground. Connector & terminal (B77) No. 3 (+) — Chassis ground (-):	Is the voltage approx. 10 V or more?	Go to step 2.	Repair the DC power supply circuit.
2 CHECK MODE DOOR ACTUATOR. 1) Disconnect the mode door actuator connector. 2) Use a tester to measure the resistance between mode door actuator terminals. Connector & terminal (B77) No. 3 — No. 1: (B77) No. 3 — No. 2: (B77) No. 3 — No. 5: (B77) No. 3 — No. 6:	Is the resistance between 80 — 100 Ω?	Go to step 3.	Replace the mode door actuator.
3 CHECK HARNESS BETWEEN AUTO A/C CONTROL MODULE AND MODE DOOR ACTUATOR. 1) Turn the A/C and ignition switch to OFF. 2) Disconnect the auto A/C control module connector. 3) Measure the resistance between auto A/C control module and mode door actuator connector. Connector & terminal (B77) No. 1 — (i88) No. 4: (B77) No. 2 — (i88) No. 3: (B77) No. 5 — (i88) No. 2: (B77) No. 6 — (i88) No. 1:	Is the resistance less than 1 Ω?	Go to step 4.	Repair the harness between auto A/C control module and mode door actuator.
4 CHECK POOR CONTACT. Check poor contact of auto A/C control module and connector.	Is there poor contact in connector?	Repair the connector.	Replace the auto A/C control module.

Diagnostic Procedure for Actuators

HVAC SYSTEM (AUTO A/C) (DIAGNOSTICS)

Brought to you by Eris Studios
NOT FOR RESALE

C: AIR MIX DOOR ACTUATOR

TROUBLE SYMPTOM:

Outlet air temperature does not change.

WIRING DIAGRAM:

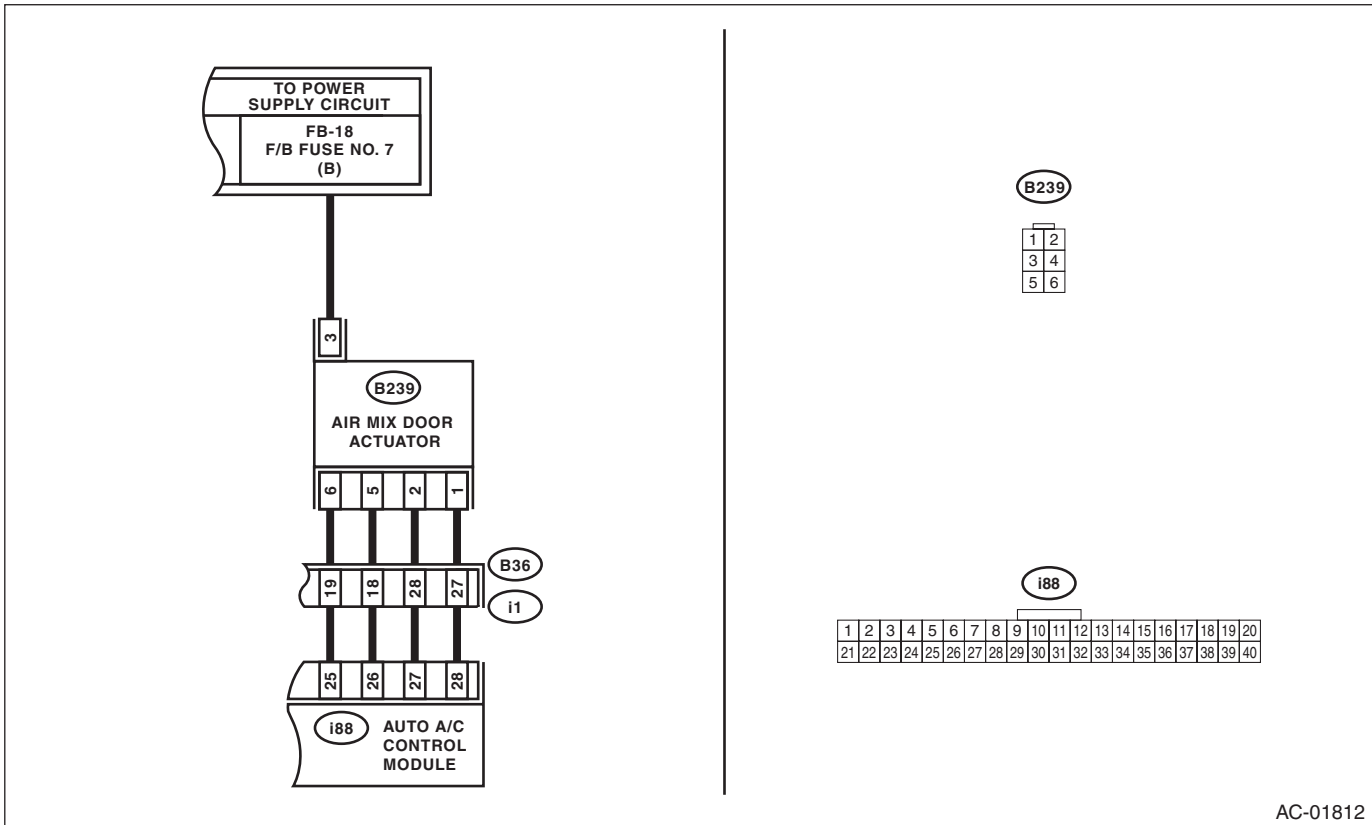

Diagnostic Procedure for Actuators

HVAC SYSTEM (AUTO A/C) (DIAGNOSTICS)

Brought to you by Eris Studios
NOT FOR RESALE

Step	Check	Yes	No
1 CHECK AIR MIX DOOR ACTUATOR POWER SUPPLY. 1) Turn the ignition switch to OFF. 2) Disconnect the air mix door actuator connector. 3) Turn the ignition switch to ON. 4) Measure the voltage between the air mix door actuator connector terminal and chassis ground. <i>Connector & terminal</i> <i>(B239) No. 3 (+) — Chassis ground (-):</i>	Is the voltage approx. 10 V or more?	Go to step 2.	Repair the DC power supply circuit.
2 CHECK AIR MIX DOOR ACTUATOR. 1) Disconnect the air mix door actuator connector. 2) Connect the negative terminal of the battery to the next terminal. Use a tester to measure the resistance between the air mix actuator terminals. <i>Connector & terminal</i> <i>(B239) No. 3 — No. 1:</i> <i>(B239) No. 3 — No. 2:</i> <i>(B239) No. 3 — No. 5:</i> <i>(B239) No. 3 — No. 6:</i>	Is the resistance between 80 — 100 Ω?	Go to step 3.	Replace the air mix door actuator.
3 CHECK HARNESS BETWEEN AUTO A/C CONTROL MODULE AND AIR MIX DOOR ACTUATOR. 1) Turn the A/C and ignition switch to OFF. 2) Disconnect the auto A/C control module connector. 3) Measure the resistance between auto A/C control module and air mix door actuator connector. <i>Connector & terminal</i> <i>(B239) No. 1 — (i88) No. 28:</i> <i>(B239) No. 2 — (i88) No. 27:</i> <i>(B239) No. 5 — (i88) No. 26:</i> <i>(B239) No. 6 — (i88) No. 25:</i>	Is the resistance less than 1 Ω?	Go to step 4.	Repair the harness between auto A/C control module and air mix door actuator.
4 CHECK POOR CONTACT. Check poor contact of auto A/C control module and connector.	Is there poor contact in connector?	Repair the connector.	Replace the auto A/C control module.

Diagnostic Procedure for Sensors

HVAC SYSTEM (AUTO A/C) (DIAGNOSTICS)

Brought to you by Eris Studios
NOT FOR SALE

8. Diagnostic Procedure for Sensors

A: AMBIENT SENSOR

TROUBLE SYMPTOM:

- Fan speed is not switched when the fan speed control dial is in AUTO position.
- Failure related to the ambient sensor is indicated in self-diagnosis.

WIRING DIAGRAM:

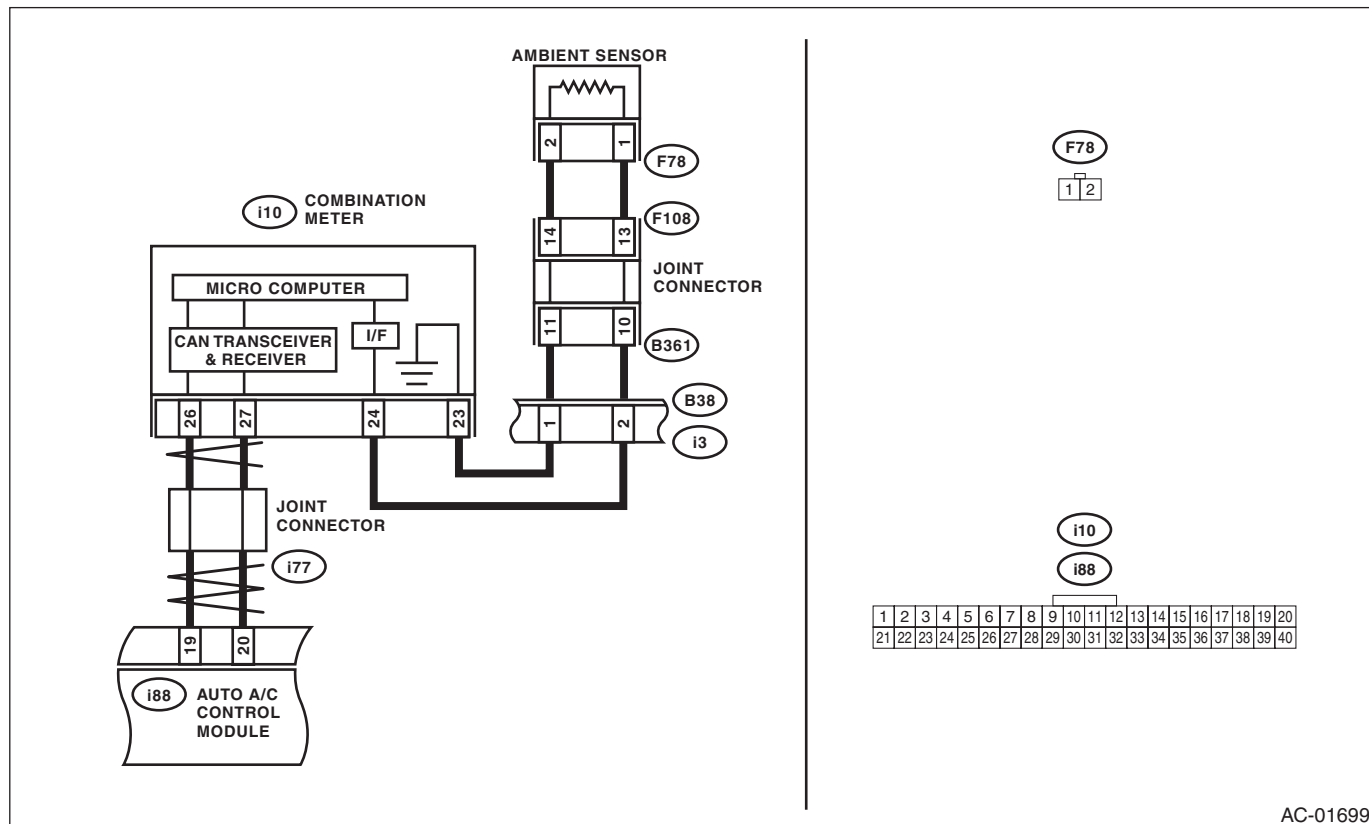

AC-01699

Step	Check	Yes	No
1 CHECK AMBIENT SENSOR. 1) Turn the ignition switch to OFF. 2) Disconnect the connector from ambient sensor. 3) Measure the resistance between terminals of ambient sensor. Terminals No. 1 — No. 2:	Is the resistance approximately 3 kΩ at 25°C (77°F) ?	Go to step 2.	Replace the ambient sensor.
2 CHECK INPUT SIGNAL FOR AMBIENT SENSOR. 1) Turn the ignition to ON. 2) Measure the voltage between connector (F78) terminals. Connector & terminal (F78) No. 1 (+) — No. 2 (-):	Is the voltage approx. 5 V?	Go to step 6.	Go to step 3.

Diagnostic Procedure for Sensors

HVAC SYSTEM (AUTO A/C) (DIAGNOSTICS)

Brought to you by Eris Studios
NOT FOR RESALE

Step	Check	Yes	No
3 CHECK COMBINATION METER OUTPUT SIGNAL. 1) Turn the ignition switch to OFF. 2) Pull out the combination meter. 3) Disconnect the connector from ambient sensor. 4) Turn the ignition switch to ON. 5) Measure the voltage between the combination meter connector terminals. <i>Connector & terminal</i> <i>(i10) No. 24 (+) — No. 23 (-):</i>	Is the voltage approx. 5 V?	Go to step 4.	Go to step 6.
4 CHECK HARNESS CONNECTOR BETWEEN COMBINATION METER AND AMBIENT TEMPERATURE SENSOR. 1) Turn the ignition switch to OFF. 2) Disconnect the connector from combination meter. 3) Measure the resistance of the harness between the combination meter and ambient temperature sensor. <i>Connector & terminal</i> <i>(F78) No. 1 — (i10) No. 24:</i>	Is the resistance less than 1 Ω ?	Go to step 5.	Repair the open circuit in the harness between the combination meter and ambient temperature sensor.
5 CHECK HARNESS CONNECTOR BETWEEN COMBINATION METER AND AMBIENT TEMPERATURE SENSOR. Measure the resistance of the harness between the combination meter and ambient temperature sensor. <i>Connector & terminal</i> <i>(F78) No. 2 — (i10) No. 23:</i>	Is resistance less than 1 Ω ?	Replace the combination meter.	Repair the open circuit in the harness between the combination meter and ambient temperature sensor.
6 CHECK HARNESS CONNECTOR BETWEEN COMBINATION METER AND AUTO A/C CONTROL MODULE. 1) Turn the ignition switch to OFF. 2) Disconnect the connector from the combination meter. 3) Disconnect the auto A/C control module connector. 4) Measure the resistance of the harness between the combination meter and auto A/C control module. <i>Connector & terminal</i> <i>(i88) No. 19 — (i10) No. 26:</i>	Is resistance less than 1 Ω ?	Go to step 7.	Repair the open circuit in the harness between the combination meter and auto A/C control module.
7 CHECK HARNESS CONNECTOR BETWEEN COMBINATION METER AND AUTO A/C CONTROL MODULE. Measure the resistance of the harness between the combination meter and auto A/C control module. <i>Connector & terminal</i> <i>(i88) No. 20 — (i10) No. 27:</i>	Is resistance less than 1 Ω ?	Go to step 8.	Repair the open circuit in the harness between the combination meter and auto A/C control module.
8 CHECK POOR CONTACT. Check poor contact of auto A/C control module connector.	Is there poor contact in connector?	Repair the connector.	Replace the auto A/C control module.

Diagnostic Procedure for Sensors

HVAC SYSTEM (AUTO A/C) (DIAGNOSTICS)

Brought to you by Eris Studios
NOT FOR SALE

B: IN-VEHICLE SENSOR

TROUBLE SYMPTOM:

- Blower fan speed, air flow outlet and FRESH/RECIRC do not change after turning the AUTO switch to ON.
- Failure related to the in-vehicle sensor is indicated in self-diagnosis.

WIRING DIAGRAM:

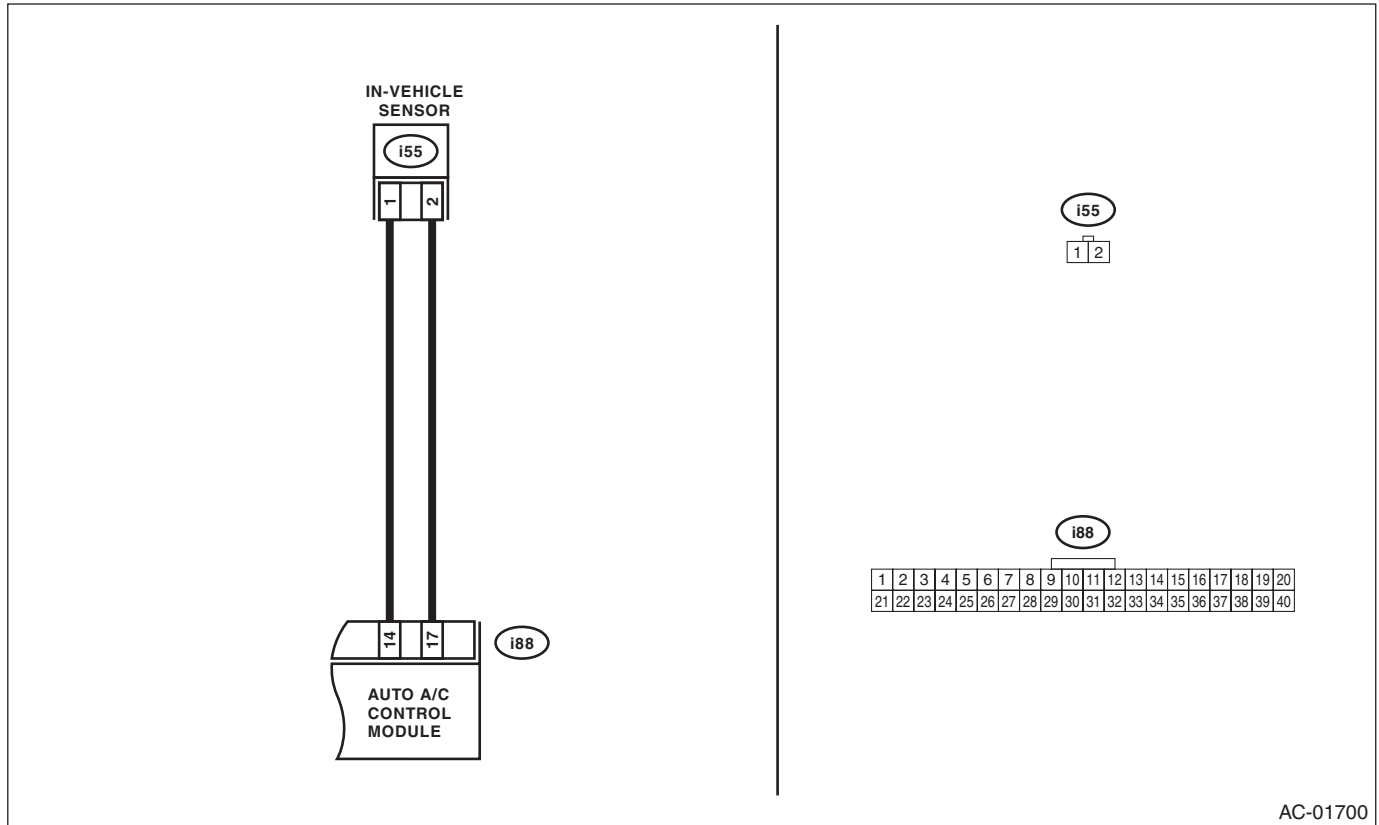

AC-01700

Diagnostic Procedure for Sensors

HVAC SYSTEM (AUTO A/C) (DIAGNOSTICS)

Brought to you by Eris Studios
NOT FOR RESALE

Step	Check	Yes	No
1 CHECK IN-VEHICLE SENSOR. 1) Turn the ignition switch to OFF. 2) Remove the driver's side lower cover. 3) Disconnect the connector from in-vehicle sensor. 4) Measure the resistance between terminals of in-vehicle sensor. Terminals No. 1 — No. 2:	Is the resistance approximately 2.2 k Ω at 25°C (77°F) ?	Go to step 2.	Replace the in-vehicle sensor.
2 CHECK INPUT SIGNAL FOR IN-VEHICLE SENSOR. 1) Turn the ignition switch to ON. 2) Measure the voltage between in-vehicle sensor harness connector terminals. Connector & terminal (i55) No. 2 (+) — No. 1 (-):	Is the voltage approx. 5 V?	Go to step 6.	Go to step 3.
3 CHECK AUTO A/C CONTROL MODULE OUTPUT SIGNAL. 1) Turn the ignition switch to OFF. 2) Remove the auto A/C control module. 3) Turn the ignition switch to ON. 4) Measure the voltage between connector terminals of auto A/C control module. Connector & terminal (i88) No. 17 (+) — (i88) No. 14 (-):	Is the voltage approx. 5 V?	Go to step 4.	Go to step 6.
4 CHECK HARNESS BETWEEN AUTO A/C CONTROL MODULE AND IN-VEHICLE SENSOR. 1) Turn the ignition switch to OFF. 2) Disconnect the connector from the auto A/C control module. 3) Measure the resistance of harness between auto A/C control module and in-vehicle sensor. Connector & terminal (i55) No. 2 — (i88) No. 17:	Is resistance less than 1 Ω ?	Go to step 5.	Repair the harness between auto A/C control module and in-vehicle sensor.
5 CHECK HARNESS BETWEEN AUTO A/C CONTROL MODULE AND IN-VEHICLE SENSOR. Measure the resistance of harness between auto A/C control module and in-vehicle sensor. Connector & terminal (i55) No. 1 — (i88) No. 14:	Is resistance less than 1 Ω ?	Go to step 6.	Repair the harness between auto A/C control module and in-vehicle sensor.
6 CHECK POOR CONTACT. Check poor contact of auto A/C control module connector.	Is there poor contact in connector?	Repair the connector.	Replace the auto A/C control module.

Diagnostic Procedure for Sensors

HVAC SYSTEM (AUTO A/C) (DIAGNOSTICS)

Brought to you by Eris Studios
NOT FOR RESALE

C: EVAPORATOR SENSOR

WIRING DIAGRAM:

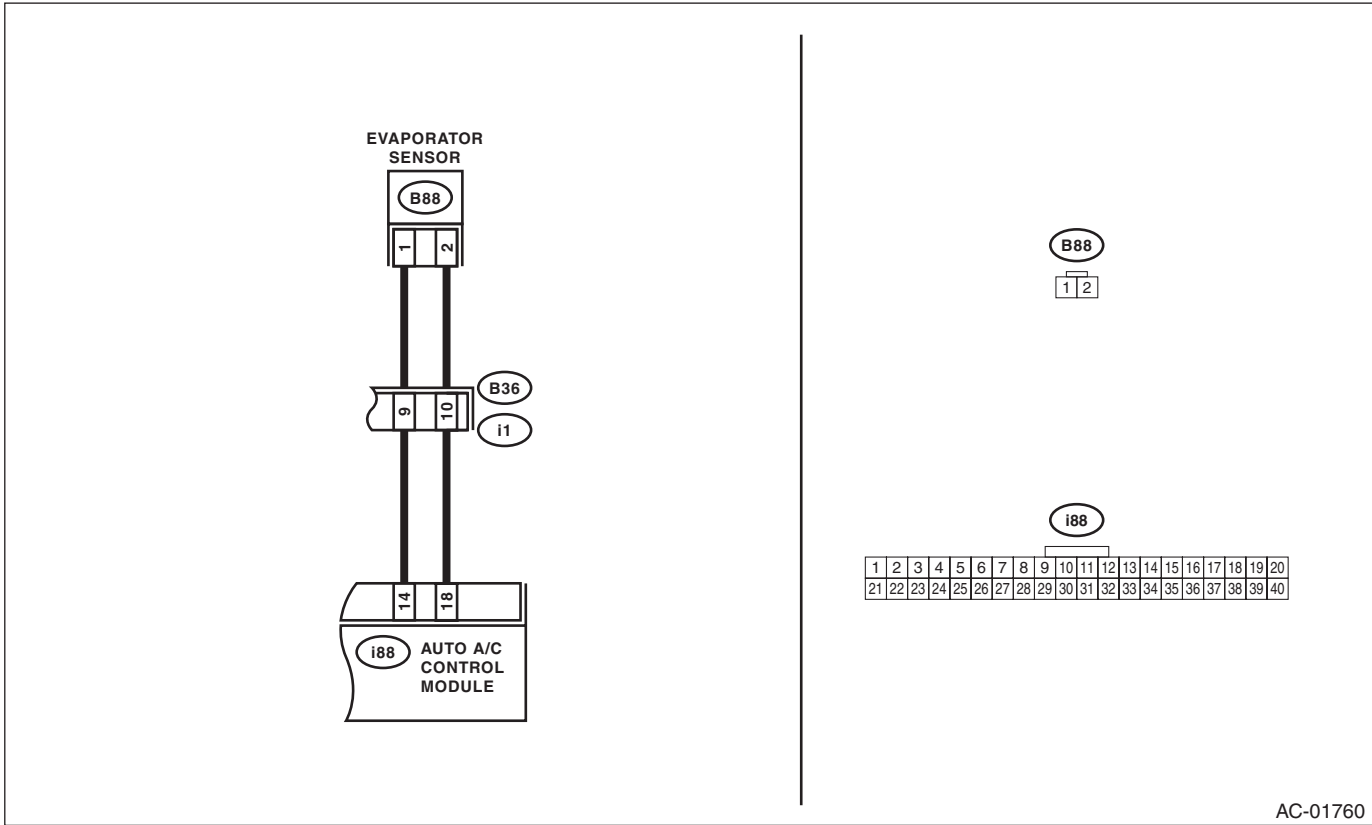

AC-01760

Diagnostic Procedure for Sensors

HVAC SYSTEM (AUTO A/C) (DIAGNOSTICS)

Brought to you by Eris Studios
NOT FOR RESALE

Step	Check	Yes	No
1 CHECK EVAPORATOR SENSOR. 1) Turn the ignition switch to OFF. 2) Remove the glove box. 3) Disconnect the connector from evaporator sensor. 4) Measure the resistance between terminals of the evaporator sensor. Terminals No. 1 — No. 2:	Is resistance approximately 6.2 k Ω at 0°C (32°F), or approximately 3.3 k Ω at 15°C (59°F) ?	Go to step 2.	Replace the evaporator sensor.
2 CHECK INPUT SIGNAL FOR EVAPORATOR SENSOR. 1) Turn the ignition switch to ON. 2) Measure the voltage between connector (B88) terminals. Connector & terminal (B88) No. 1 (+) — No. 2 (-):	Is the voltage approx. 5 V?	Go to step 6.	Go to step 3.
3 CHECK AUTO A/C CONTROL MODULE OUTPUT SIGNAL. 1) Turn the ignition switch to OFF. 2) Remove the auto A/C control module. 3) Turn the ignition switch to ON. 4) Measure the voltage between connector terminals of auto A/C control module. Connector & terminal (i88) No. 18 (+) — (i88) No. 14 (-):	Is the voltage approx. 5 V?	Go to step 4.	Go to step 6.
4 CHECK HARNESS CONNECTOR BETWEEN AUTO A/C CONTROL MODULE AND EVAPORATOR SENSOR. 1) Turn the ignition switch to OFF. 2) Disconnect the connector from the auto A/C control module. 3) Measure the resistance of harness between auto A/C control module and evaporator sensor. Connector & terminal (B88) No. 2 — (i88) No. 18:	Is the resistance less than 1 Ω ?	Go to step 5.	Repair the open circuit of harness between auto A/C control module and evaporator sensor.
5 CHECK HARNESS CONNECTOR BETWEEN AUTO A/C CONTROL MODULE AND EVAPORATOR SENSOR. Measure the resistance of harness between auto A/C control module and evaporator sensor. Connector & terminal (B88) No. 1 — (i88) No. 14:	Is the resistance less than 1 Ω ?	Go to step 6.	Repair the open circuit of harness between auto A/C control module and evaporator sensor.
6 CHECK POOR CONTACT. Check poor contact of auto A/C control module connector.	Is there poor contact in connector?	Repair the connector.	Replace the auto A/C control module.

Diagnostic Procedure for Sensors

HVAC SYSTEM (AUTO A/C) (DIAGNOSTICS)

Brought to you by Eris Studios
NOT FOR SALE

D: SUNLOAD SENSOR

TROUBLE SYMPTOM:

- Sensor identifies that sunlight is at maximum. Then, A/C system is controlled to COOL side.
- Sensor identifies that sunlight is at minimum. Then, A/C system is controlled to HOT side.

NOTE:

When the sunload sensor check is performed indoors or in the shade, it could be diagnosed as having an open circuit. Always check the sunload sensor with the sun shining on it.

WIRING DIAGRAM:

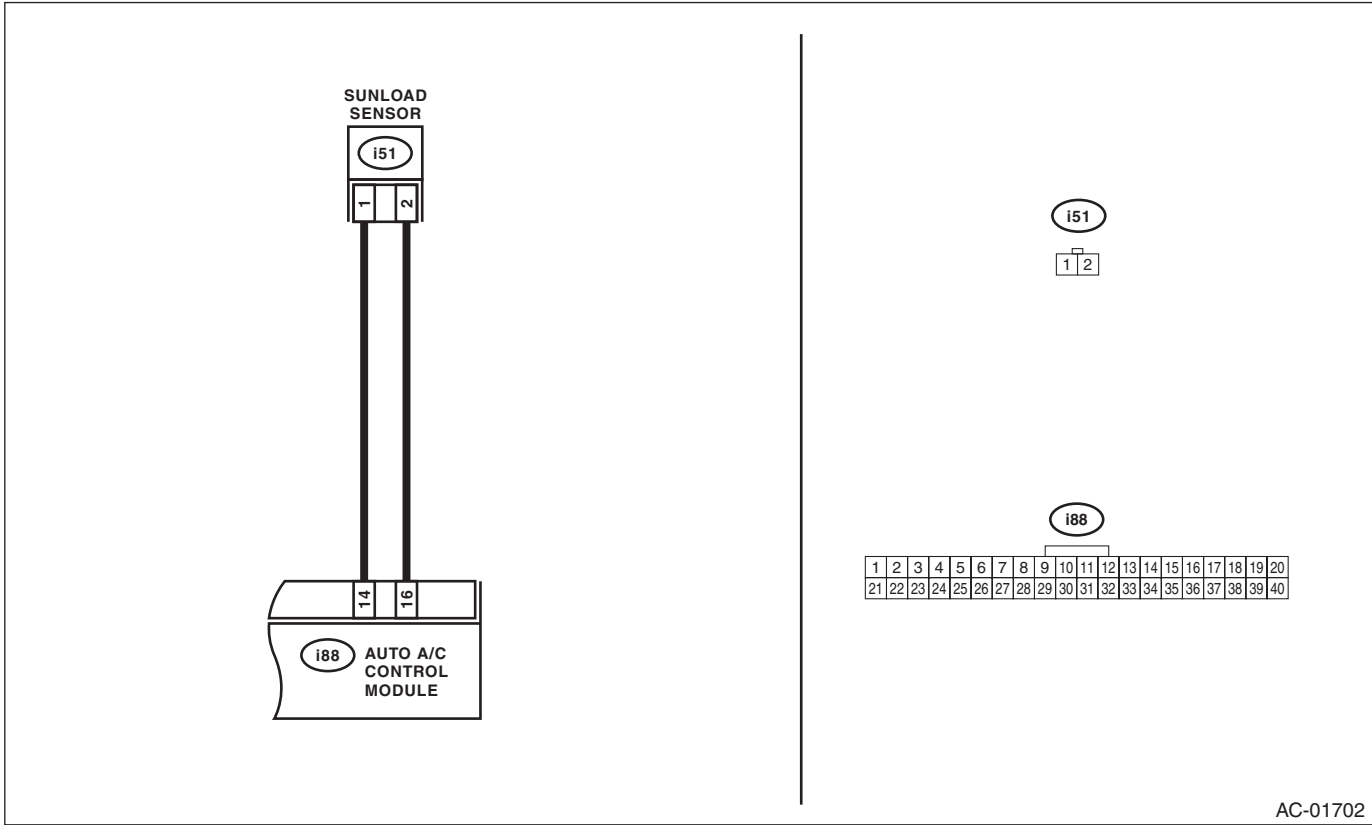

AC-01702

Diagnostic Procedure for Sensors

HVAC SYSTEM (AUTO A/C) (DIAGNOSTICS)

Brought to you by Eris Studios
NOT FOR RESALE

	Step	Check	Yes	No
1	<p>CHECK POWER SUPPLY VOLTAGE FOR SUNLOAD SENSOR.</p> <p>1) Turn the ignition switch to OFF. 2) Disconnect the connector from sunload sensor. 3) Turn the ignition switch to ON. 4) Measure the power supply voltage for sunload sensor.</p> <p>Connector & terminal (i51) No. 2 (+) — No. 1 (-):</p>	Is the voltage approx. 5 V?	Go to step 4.	Go to step 2.
2	<p>CHECK HARNESS CONNECTOR BETWEEN AUTO A/C CONTROL MODULE AND SUNLOAD SENSOR.</p> <p>1) Turn the ignition switch to OFF. 2) Disconnect the connector from the auto A/C control module. 3) Measure the resistance of the harness between the auto A/C control module and sunload sensor.</p> <p>Connector & terminal (i51) No. 2 — (i88) No. 16:</p>	Is resistance less than 1 Ω?	Go to step 3.	Repair the harness between auto A/C control module and sunload sensor.
3	<p>CHECK HARNESS CONNECTOR BETWEEN AUTO A/C CONTROL MODULE AND SUNLOAD SENSOR.</p> <p>Measure the resistance of the harness between the auto A/C control module and sunload sensor.</p> <p>Connector & terminal (i51) No. 1 — (i88) No. 14:</p>	Is resistance less than 1 Ω?	Go to step 4.	Repair the harness between auto A/C control module and sunload sensor.
4	<p>CHECK INPUT VOLTAGE FOR AUTO A/C CONTROL MODULE.</p> <p>1) Connect the connectors of sunload sensor and auto A/C control module. 2) Turn the ignition switch to ON. 3) Measure the voltage between connector terminals of auto A/C control module.</p> <p>Connector & terminal (i88) No. 16 (+) — (i88) No. 14 (-):</p>	Is the voltage within approximately 1.0 — 4.0 V?	Go to step 5.	Replace the sunload sensor.
5	<p>CHECK POOR CONTACT.</p> <p>Check poor contact of auto A/C control module connector.</p>	Is there poor contact in connector?	Repair the connector.	Replace the auto A/C control module.

Diagnostics with Phenomenon

HVAC SYSTEM (AUTO A/C) (DIAGNOSTICS)

Brought to you by Eriss Studios
NOT FOR SALE

9. Diagnostics with Phenomenon

A: INSPECTION

Symptoms	Problem parts
A/C system fails to operate.	<ul style="list-style-type: none"> • Fuse (M/B No. 8, F/B No. 22, 31) • Connector (Poor contact) • Ground • Auto A/C control module • Blower fan motor • Blower fan relay • A/C relay • Compressor (Magnet clutch) • Evaporator sensor
Fuse is blown out.	<ul style="list-style-type: none"> • Fuse (M/B No. 8, F/B No. 22, 31) • Connector (Poor contact)
Illumination cannot dim.	<ul style="list-style-type: none"> • Fuse (M/B No. 8, F/B No. 22, 31) • Connector (Poor contact) • Auto A/C control module
Blower fan does not rotate or fan speed cannot be controlled.	<ul style="list-style-type: none"> • Fuse (M/B No. 8, F/B No. 22, 31) • Connector (Poor contact) • Ground • Auto A/C control module • Blower fan motor • Blower fan relay
Unable to switch suction vents.	<ul style="list-style-type: none"> • Connector (Poor contact) • Auto A/C control module • Intake door actuator
Unable to switch vents.	<ul style="list-style-type: none"> • Connector (Poor contact) • Auto A/C control module • Mode door actuator
Room temperature does not rise (Warm air does not come out).	<ul style="list-style-type: none"> • Connector (Poor contact) • Auto A/C control module • Air mix door actuator • In-vehicle sensor, ambient sensor, evaporator sensor and sunload sensor • In-vehicle sensor aspirator hose
Room temperature does not lower (Cold air does not come out).	<ul style="list-style-type: none"> • Connector (Poor contact) • Auto A/C control module • Air mix door actuator • A/C relay • Compressor (Magnet clutch) • Radiator fan motor • Radiator fan relay • In-vehicle sensor, ambient sensor, evaporator sensor and sunload sensor • In-vehicle sensor aspirator hose
Compartment temperature is higher or lower than setting temperature.	<ul style="list-style-type: none"> • Auto A/C control module • Air mix door actuator • In-vehicle sensor, ambient sensor, evaporator sensor and sunload sensor • In-vehicle sensor aspirator hose
Compartment temperature does not quickly respond to setting temperature.	<ul style="list-style-type: none"> • Air mix door actuator • In-vehicle sensor, ambient sensor, evaporator sensor and sunload sensor • In-vehicle sensor aspirator hose
Radiator fan does not rotate during A/C operation.	<ul style="list-style-type: none"> • Radiator fan motor • Radiator fan relay

Diagnostics with Phenomenon

HVAC SYSTEM (AUTO A/C) (DIAGNOSTICS)

Brought to you by Eris Studios
NOT FOR RESALE