

Brought to you by Eris Studios
NOT FOR RESALE

GLASS/WINDOWS/MIRRORS

General Description

GLASS/WINDOWS/MIRRORS

Brought to you by Eris Studios
NOT FOR RESALE

1. General Description

A: COMPONENT

1. FIXED GLASS (WAGON MODEL)

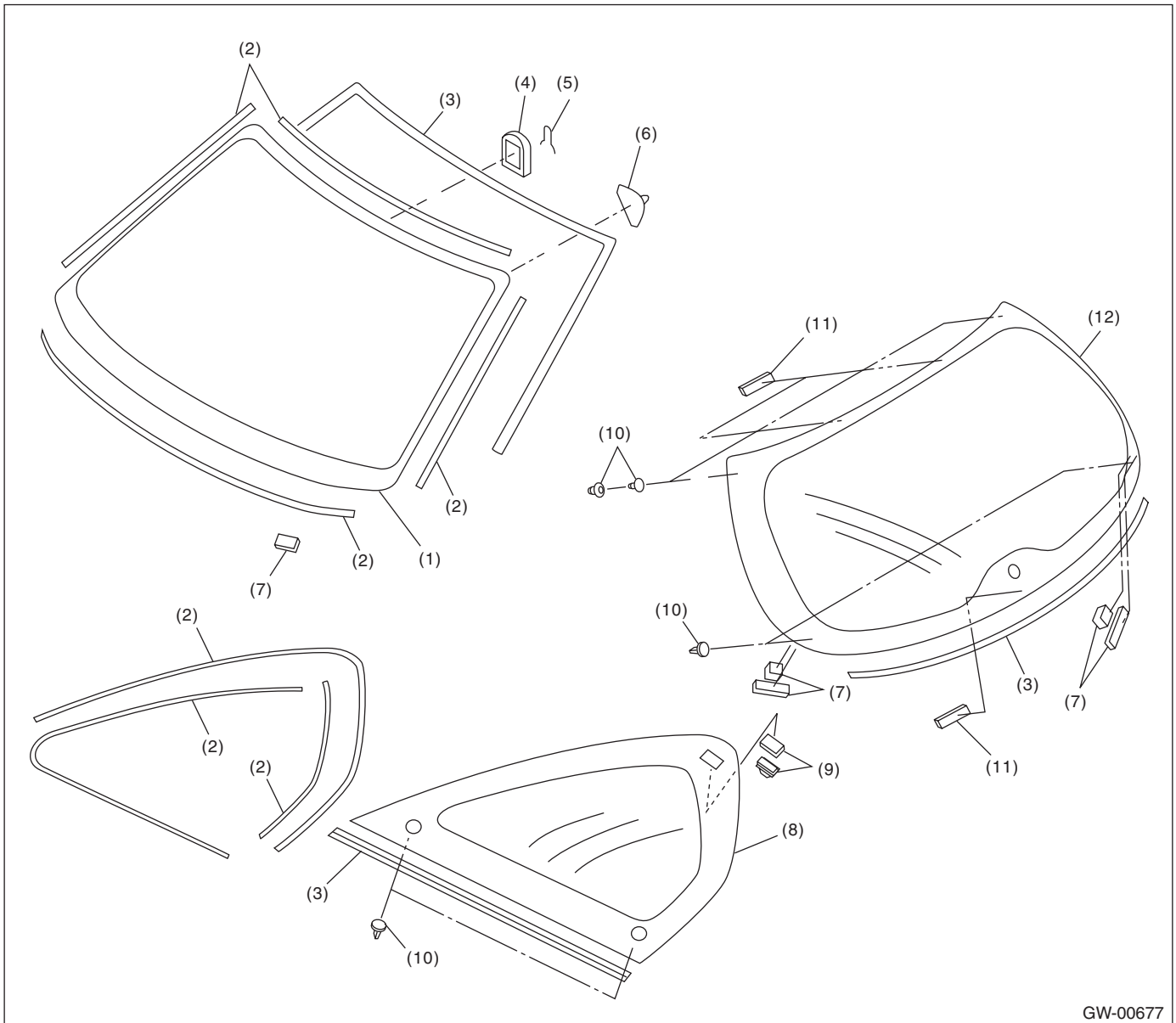

GW-00677

- | | | |
|---------------------------|------------------------|----------------------|
| (1) Windshield glass | (5) Spring | (9) Fastener |
| (2) Dam rubber | (6) Locating pin | (10) Locating pin |
| (3) Molding | (7) Seal | (11) Spacer |
| (4) Rearview mirror mount | (8) Rear quarter glass | (12) Rear gate glass |

Brought to you by
 NOT FOR SALE
 Chris Studios

2. FIXED GLASS (SEDAN MODEL)

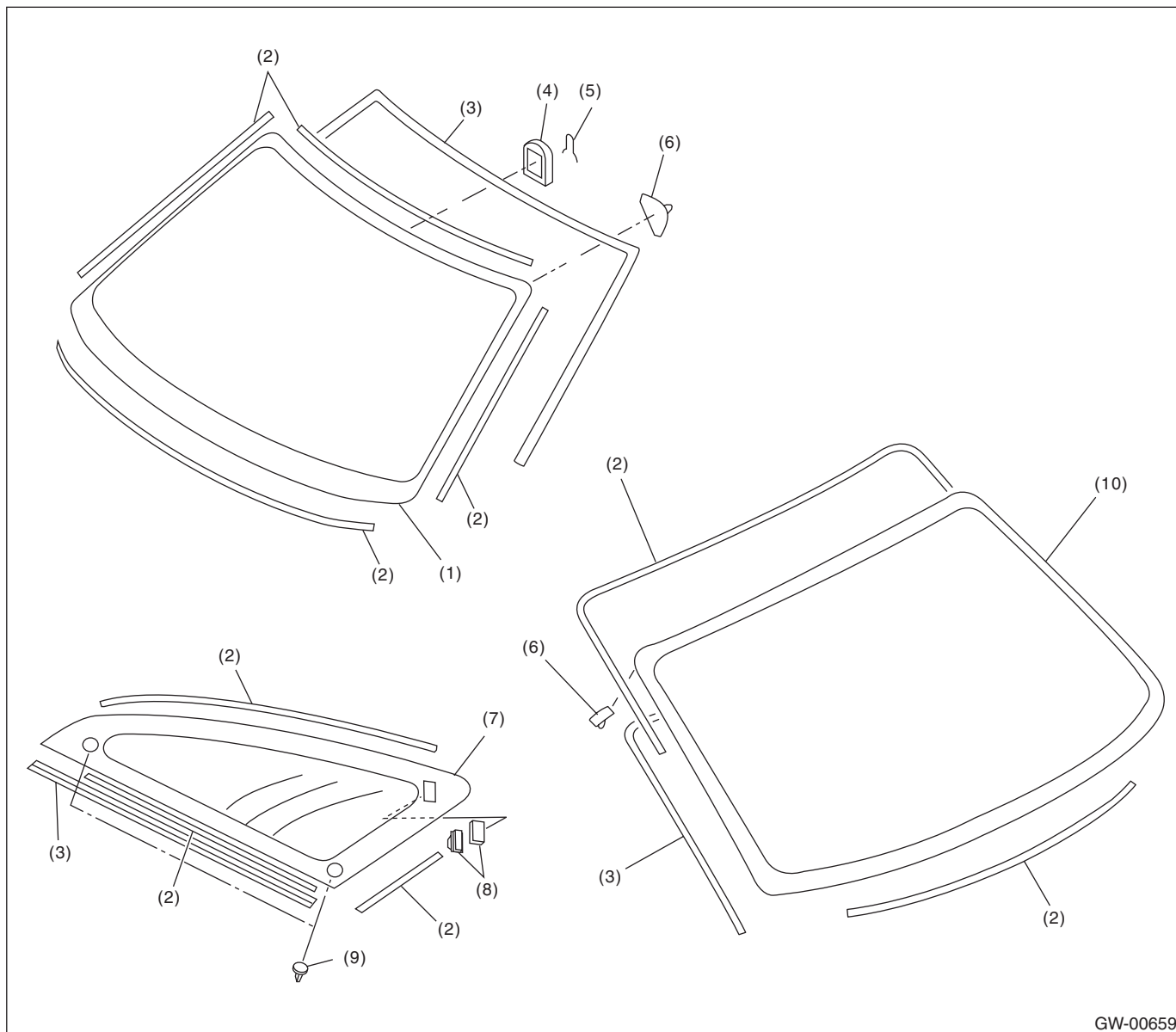

GW-00659

- | | | |
|---------------------------|------------------|------------------------|
| (1) Windshield glass | (5) Spring | (9) Locating pin |
| (2) Dam rubber | (6) Locating pin | (10) Rear window glass |
| (3) Molding | (7) Side glass | |
| (4) Rearview mirror mount | (8) Fastener | |

General Description

GLASS/WINDOWS/MIRRORS

Brought to you by Eris Studios
NOT FOR RESALE

3. FRONT DOOR GLASS

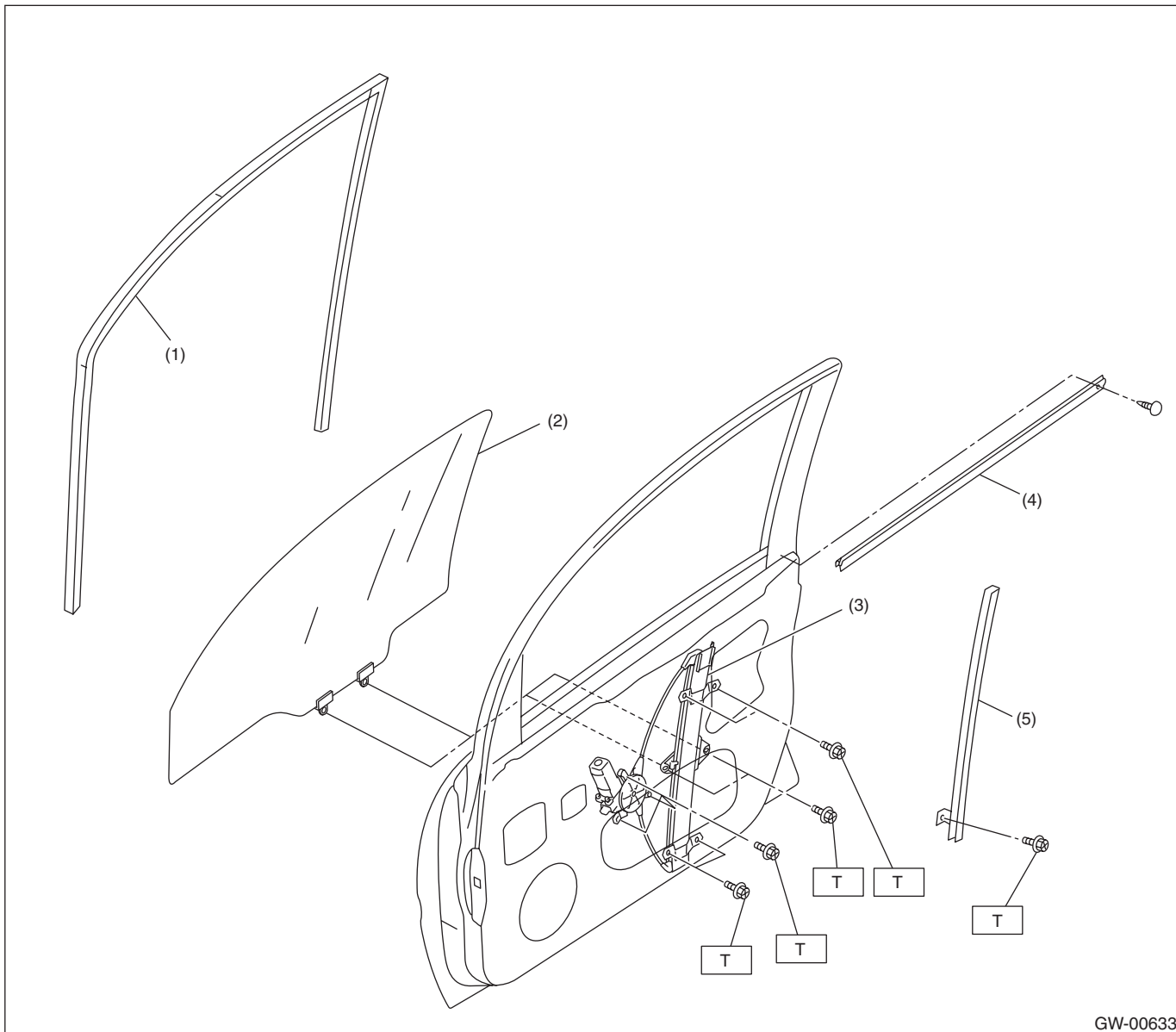

GW-00633

- (1) Glass run rubber
- (2) Glass
- (3) Motor & regulator ASSY

- (4) Weather strip
- (5) Door sash

Tightening torque: N·m (kgf·m, ft·lb)

T: 7.4 (0.75, 5.5)

4. REAR DOOR GLASS

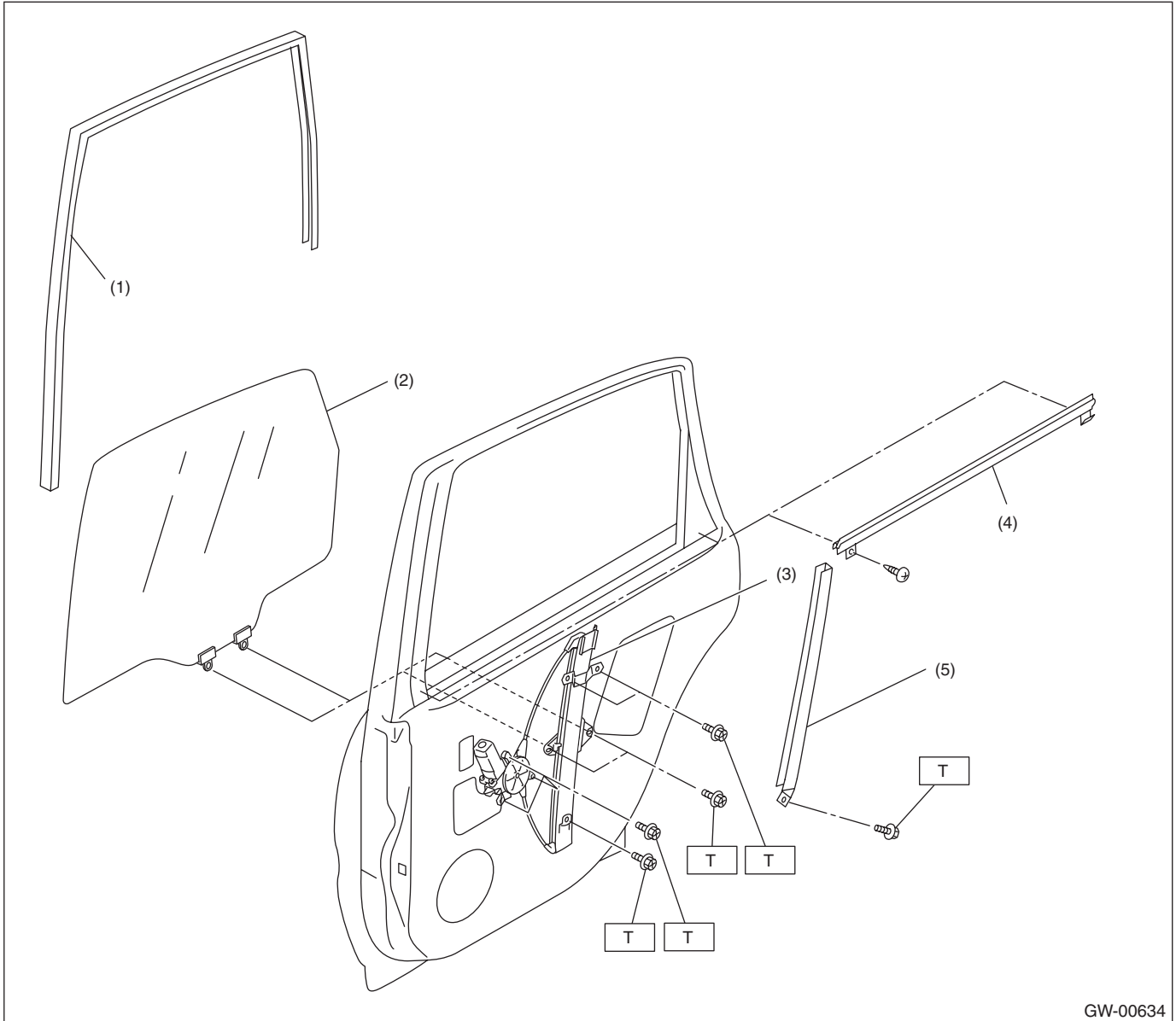

- (1) Glass run rubber
- (2) Glass
- (3) Motor & regulator ASSY

- (4) Weather strip
- (5) Door sash

Tightening torque: N·m (kgf·m, ft·lb)

T: 7.4 (0.75, 5.5)

General Description

GLASS/WINDOWS/MIRRORS

Brought to you by Eris Studios
NOT FOR RESALE

5. MIRROR

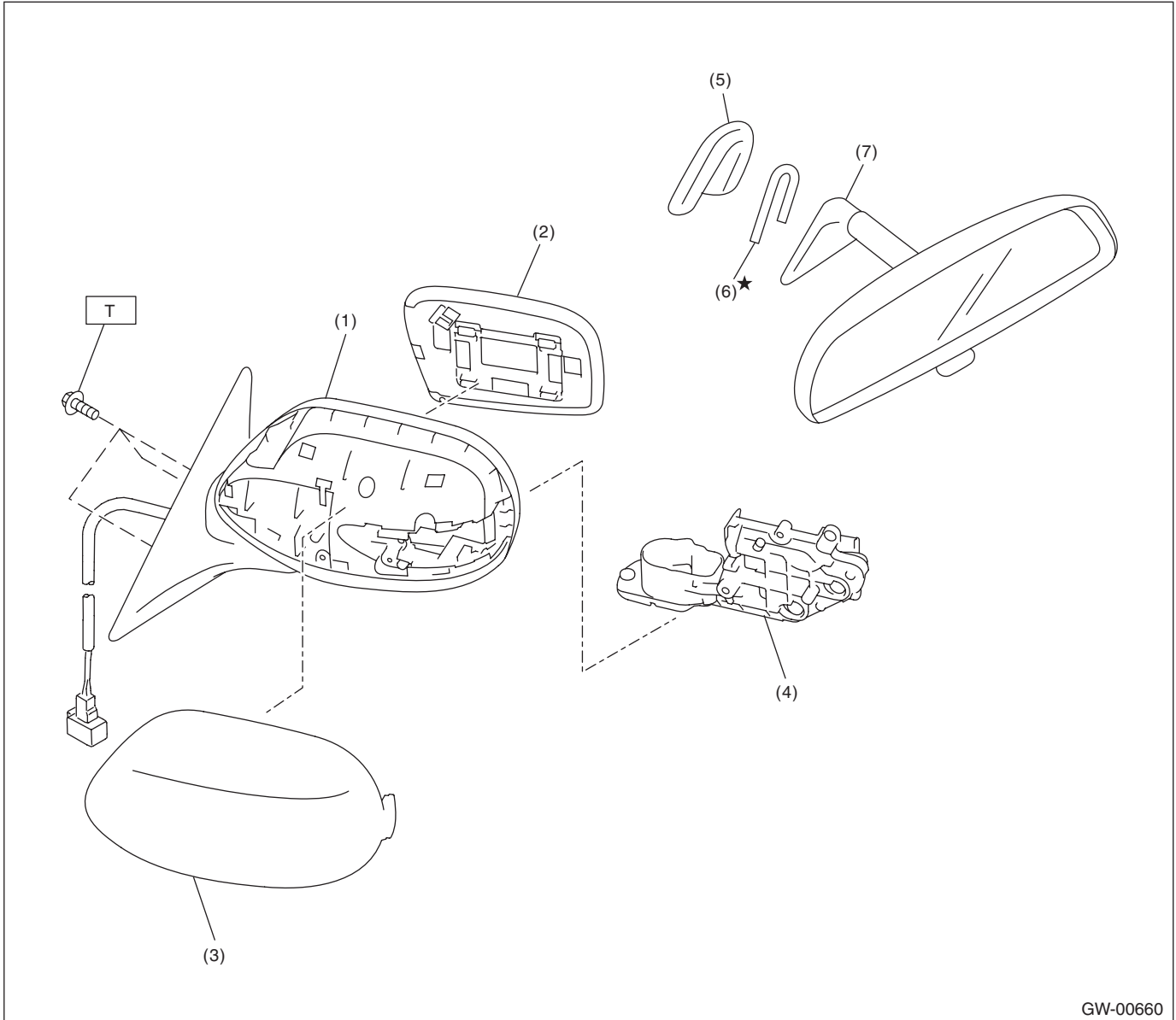

GW-00660

- | | |
|----------------------------|--------------------------|
| (1) Outer mirror case ASSY | (5) Mount |
| (2) Mirror | (6) Spring |
| (3) Scalp cap | (7) Rearview mirror ASSY |
| (4) Mirror motor ASSY | |

Tightening torque: N·m (kgf·m, ft·lb)

T: 4.5 (0.46, 3.3)

B: CAUTION

- When electrical connectors are disconnected, always conduct an operational check after connecting them again.
- Avoid impact and damage to the glass.

C: PREPARATION TOOL

1. SPECIAL TOOL

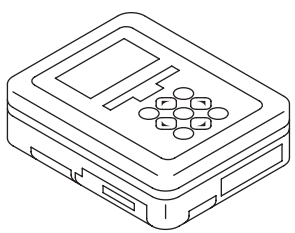
ILLUSTRATION	TOOL NUMBER	TOOL NAME	REMARKS
 ST1B021XU0	1B021XU0	SUBARU SELECT MONITOR III KIT	Used for settings of each function and troubleshooting for electrical system.

2. GENERAL TOOL

TOOL NAME	REMARKS
Circuit tester	Used for checking voltage and continuity.
Piano wire	Used for removing the window glass.
Cutter knife	Used for removing the window glass.
Windshield glass knife	Used for removing the window glass.

Power Window System

GLASS/WINDOWS/MIRRORS

Brought to you by Eris Studios
NOT FOR RESALE

2. Power Window System

A: WIRING DIAGRAM

<Ref. to WI-187, WIRING DIAGRAM, Power Window System.>

B: INSPECTION

Symptom	Repair order
All power windows do not operate.	<ol style="list-style-type: none">1. Fuse (SBF-4)2. Power window circuit breaker3. Power window relay4. Wiring harness
Particular window does not operate.	<ol style="list-style-type: none">1. Power window main switch2. Power window sub-switch3. Power window motor4. Wiring harness
"Window Lock" does not operate.	Power window main switch

C: NOTE

For removal of each component of the power window system, refer to the respective section.

- Power window control switch <Ref. to GW-9, Power Window Control Switch.>
- Front door glass <Ref. to GW-11, Front Door Glass.>
- Front regulator & motor assembly <Ref. to GW-12, Front Regulator and Motor Assembly.>
- Rear door glass <Ref. to GW-18, Rear Door Glass.>
- Rear regulator & motor assembly <Ref. to GW-19, Rear Regulator and Motor Assembly.>

3. Power Window Control Switch

A: REMOVAL

1. MAIN SWITCH

- 1) Disconnect the ground cable from the battery.
- 2) Open the screw cover by using a flat tip screwdriver.
- 3) Remove the screw to remove the power window main switch panel.

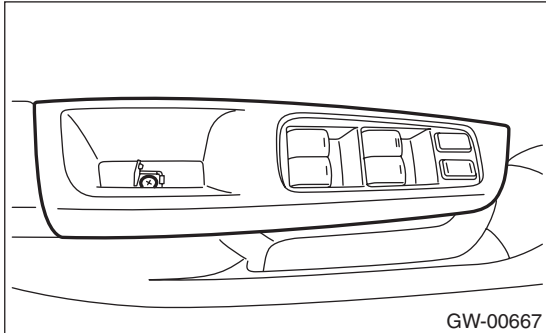

NOTE:
Remove it from the cutout portion at the tip of the switch panel.

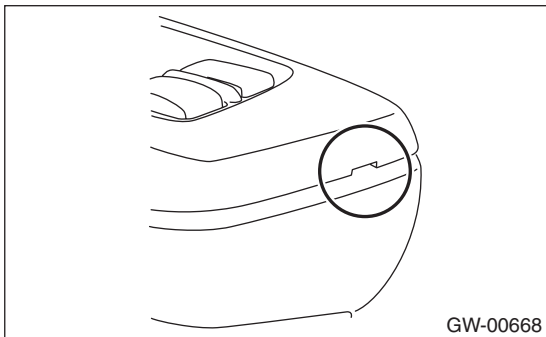

- 4) Disconnect the connector.
- 5) Remove the screw to remove the power window main switch assembly.

2. SUB-SWITCH

- 1) Open the screw cover by using a flat tip screwdriver.
- 2) Remove the screw to remove the power window main switch panel.

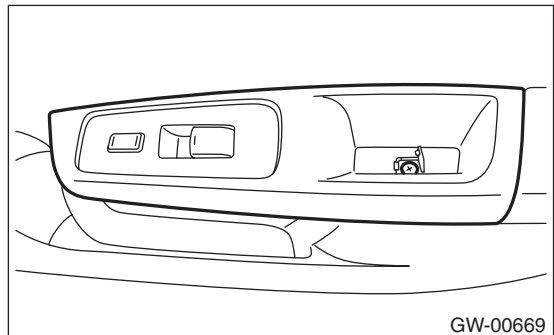

NOTE:
Remove it from the cutout portion at the tip of the switch panel.

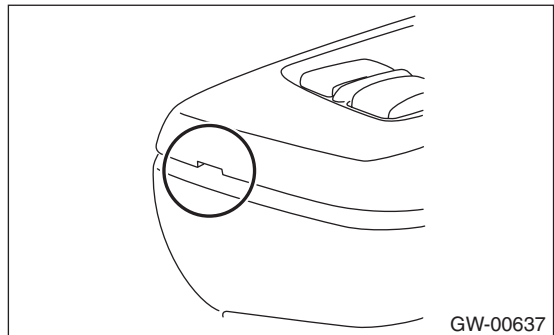

- 3) Disconnect the connector.
- 4) Remove the screw to remove the power window main switch assembly.

B: INSTALLATION

Install in the reverse order of removal.

Power Window Control Switch

GLASS/WINDOWS/MIRRORS

Brought to you by Eris Studios
NOT FOR RESALE

C: INSPECTION

1. MAIN SWITCH

- 1) Remove the main switch. <Ref. to GW-9, MAIN SWITCH, REMOVAL, Power Window Control Switch.>
- 2) Measure the switch resistance.

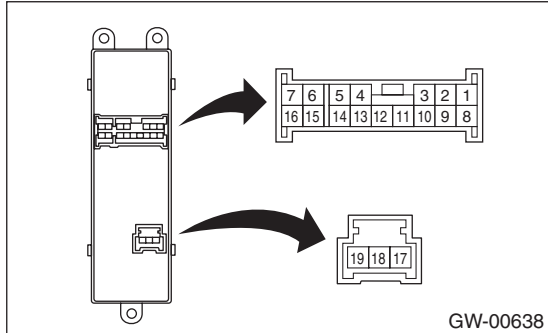

2. SUB-SWITCH

- 1) Remove the sub-switch. <Ref. to GW-9, SUB-SWITCH, REMOVAL, Power Window Control Switch.>
- 2) Measure the sub-switch resistance.

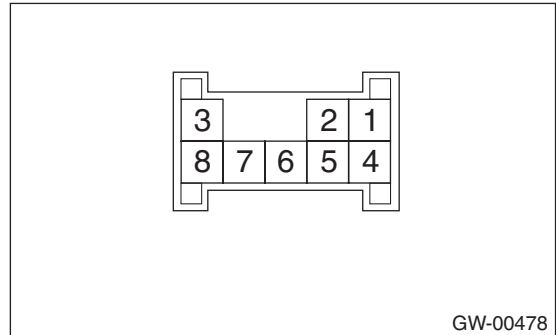

	Switch position	Terminal No.	Standard
Driver's side	UP	14 and 16 13 and 19	Less than 1 Ω
	OFF	14 and 13 14 and 16	1 MΩ or more
		17 and 18	Less than 1 Ω
	DOWN	14 and 13 16 and 19	Less than 1 Ω
	AUTO DOWN	14 and 13 16 and 19	Less than 1 Ω
Passen-ger's side	UP	14 and 8 12 and 19	Less than 1 Ω
	OFF	14 and 12 14 and 8	1 MΩ or more
		8 and 12 8 and 19 12 and 19	Less than 1 Ω
DOWN	14 and 12 8 and 19	Less than 1 Ω	
Rear LH	UP	14 and 7 5 and 19	Less than 1 Ω
	OFF	14 and 7 14 and 5	1 MΩ or more
		19 and 7 19 and 5 7 and 5	Less than 1 Ω
DOWN	14 and 5 7 and 19	Less than 1 Ω	
Rear RH	UP	14 and 1 3 and 19	Less than 1 Ω
	OFF	14 and 1 14 and 3	1 MΩ or more
		19 and 3 19 and 1 3 and 1	Less than 1 Ω
DOWN	14 and 3 1 and 19	Less than 1 Ω	

	Switch position	Terminal No.	Standard
Passenger seat, rear	UP	4 and 5 6 and 7	Less than 1 Ω
	OFF	7 and 4 8 and 4	1 MΩ or more
		5 and 8 6 and 7	Less than 1 Ω
	DOWN	4 and 6 5 and 8	Less than 1 Ω

Replace the sub-switch if faulty.

Replace the main switch if faulty.

4. Front Door Glass

A: REMOVAL

- 1) Remove the front door trim. <Ref. to EI-43, REMOVAL, Door Trim.>
- 2) Remove the sealing cover. <Ref. to EB-20, REMOVAL, Front Sealing Cover.>
- 3) Remove the pad.
- 4) Operate the power window switch to move the glass, and remove the two bolts.

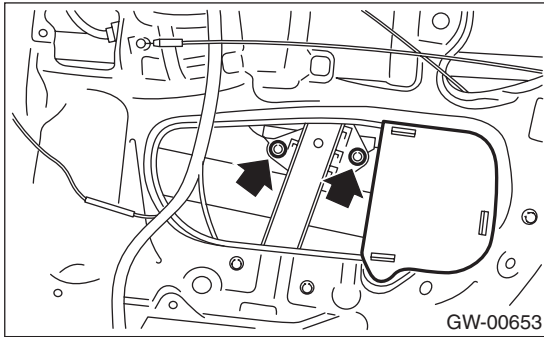

- 5) Tilt the door glass forward and remove the door glass from the glass run rubber.
- 6) Remove the door glass.

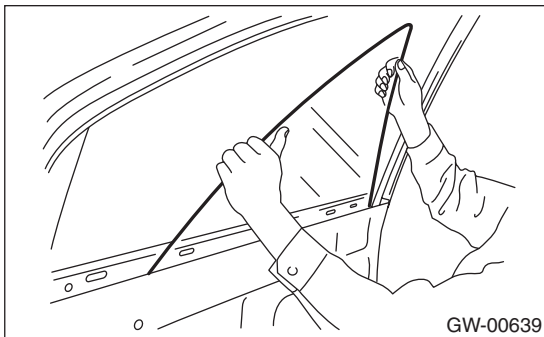

CAUTION:
Avoid impact and damage to the glass.

B: INSTALLATION

Install in the reverse order of removal.

CAUTION:
Make sure that the glass run rubber is placed securely onto the door frame and sash.

Tightening torque:
Refer to “COMPONENT” of “General Description”. <Ref. to GW-4, FRONT DOOR GLASS, COMPONENT, General Description.>

5. Front Regulator and Motor Assembly

A: REMOVAL

- 1) Remove the door glass. <Ref. to GW-11, REMOVAL, Front Door Glass.>
- 2) Disconnect the motor connector.
- 3) Remove seven bolts to remove the regulator and motor assembly.

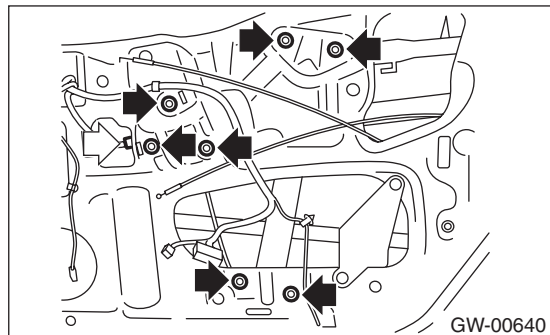

B: INSTALLATION

Install in the reverse order of removal.

Tightening torque:

Refer to “COMPONENT” of “General Description”. <Ref. to GW-4, FRONT DOOR GLASS, COMPONENT, General Description.>

C: INSPECTION

- 1) Make sure that the power window motor rotates properly when the battery voltage is applied to the terminals of motor connector.
- 2) Change polarity of battery connection to terminals to ensure that the motor rotates in reverse direction.

6. Remote Control Mirror System

A: WIRING DIAGRAM

<Ref. to WI-191, WIRING DIAGRAM, Remote Control Mirror System.>

B: INSPECTION

Symptom	Repair order
All function does not operate.	<ol style="list-style-type: none"> 1. Fuse (F/B No. 6) 2. Mirror switch 3. Wiring harness
One side of the mirror motor does not operate.	<ol style="list-style-type: none"> 1. Mirror switch 2. Mirror motor 3. Wiring harness
Mirror heater does not operate.	<ol style="list-style-type: none"> 1. Defogger switch 2. Mirror heater 3. Wiring harness

C: NOTE

For removal of each component of the remote control mirror system, refer to the respective section.

- Scalp cap <Ref. to GW-14, Scalp Cap.>
- Outer mirror assembly <Ref. to GW-15, Outer Mirror Assembly.>
- Outer mirror <Ref. to GW-16, Outer Mirror.>
- Remote control mirror switch <Ref. to GW-17, Remote Control Mirror Switch.>

7. Scalp Cap

A: REPLACEMENT

- 1) Remove the mirror. <Ref. to GW-16, REPLACEMENT, Outer Mirror.>
- 2) Press-in the clips (A) from inside of outer mirror.

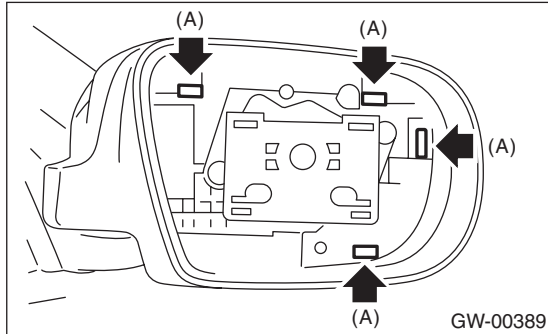

- 3) Pull the scalp cap towards the front of the outer mirror, then remove the scalp cap.
- 4) Align clip (A) on the reverse side of the scalp cap and the clip attachment hole of the outer mirror, and push the scalp cap in.

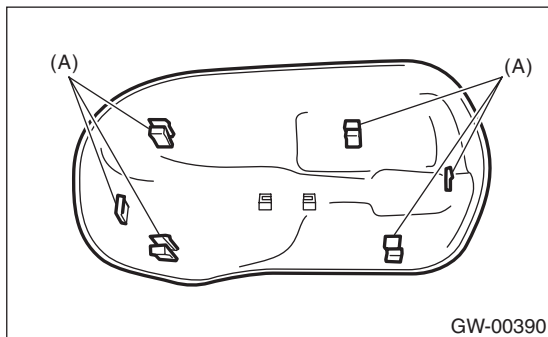

- 5) Install the scalp cap securely.

8. Outer Mirror Assembly

A: REMOVAL

- 1) Remove the front door trim. <Ref. to EI-43, REMOVAL, Door Trim.>
- 2) Disconnect the outer mirror connector.
- 3) Remove the bolt, and remove the outer mirror assembly.

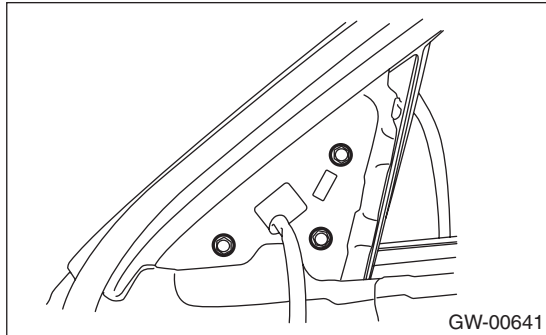

B: INSTALLATION

Install in the reverse order of removal.

Tightening torque:

4.5 N·m (0.46 kgf·m, 3.3 ft·lb)

C: INSPECTION

Check to ensure that the outer mirror moves properly when the battery voltage is applied to terminals.

Model without mirror heater

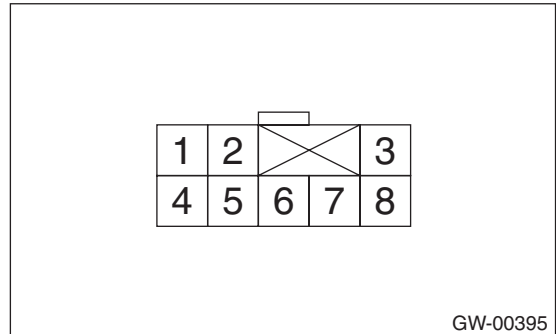

Switch position	Terminal No.
OFF	—
UP	6 (+) and 3 (-)
DOWN	3 (+) and 6 (-)
LEFT	7 (+) and 3 (-)
RIGHT	3 (+) and 7 (-)

Replace the outer mirror if defective.

Model with mirror heater

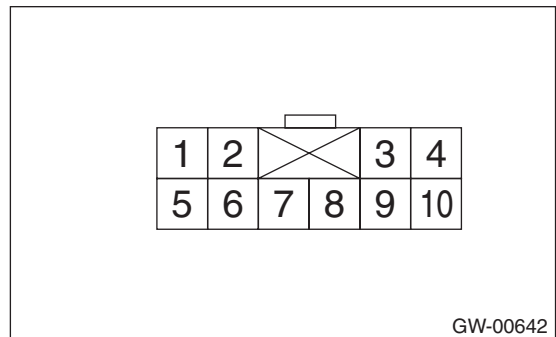

Switch position	Terminal No.
OFF	—
UP	7 (+) and 3 (-)
DOWN	3 (+) and 7 (-)
LEFT	8 (+) and 3 (-)
RIGHT	3 (+) and 8 (-)

Replace the outer mirror if defective.

9. Outer Mirror

A: REPLACEMENT

- 1) Face the mirror upward.
- 2) Use a flat tip screwdriver to remove clip (A).
- 3) Lift the lower mirror up to remove hooks (B).

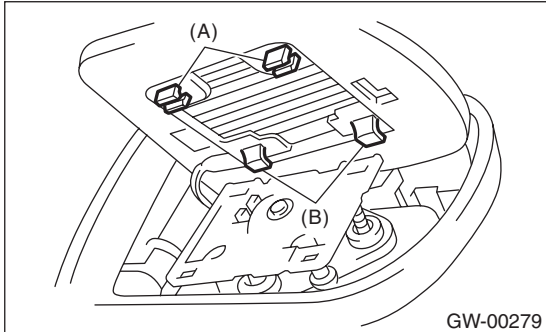

- 4) Disconnect the mirror heater connector from side of the mirror. (Model with mirror heater)

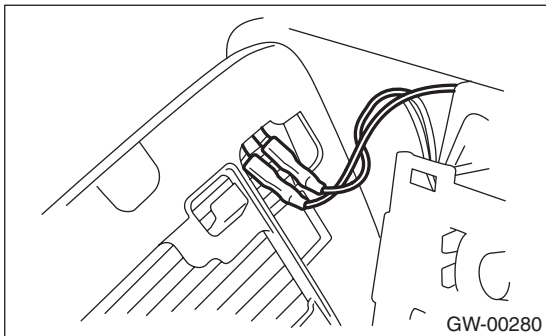

- 5) Catch the hooks (B) and install clips (A).

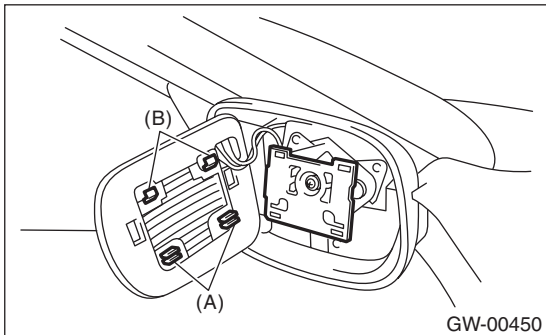

CAUTION:

- When removing the mirror, be careful not to damage the back surface of mirror with a flat tip screwdriver.
- When installing the mirror, insert the hook and clip securely.

10. Remote Control Mirror Switch

A: REMOVAL

- 1) Remove the instrument panel lower cover. <Ref. to EI-45, REMOVAL, Instrument Panel Lower Cover.>
- 2) Remove the remote control mirror switch from instrument panel lower cover.

B: INSTALLATION

Install in the reverse order of removal.

C: INSPECTION

Move the remote control mirror switch to each position and check continuity between terminals.

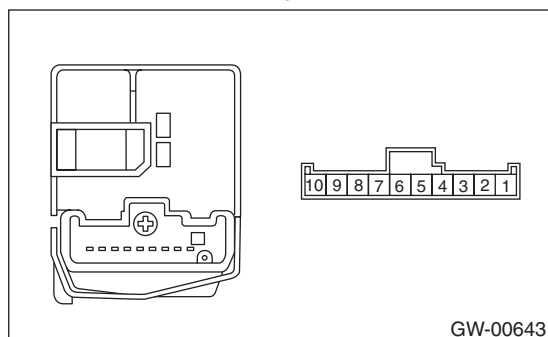

- Switch the change over switch to the right side:

Switch position	Terminal No.	Standard
OFF	—	1 MΩ or more
UP	8 and 3, 6 and 7	Less than 1 Ω
DOWN	8 and 6, 3 and 7	Less than 1 Ω
LEFT	8 and 2, 6 and 7	Less than 1 Ω
RIGHT	8 and 6, 2 and 7	Less than 1 Ω

- Switch the change over switch to the left side:

Switch position	Terminal No.	Standard
OFF	—	1 MΩ or more
UP	8 and 4, 6 and 7	Less than 1 Ω
DOWN	8 and 6, 4 and 7	Less than 1 Ω
LEFT	8 and 5, 6 and 7	Less than 1 Ω
RIGHT	8 and 6, 5 and 7	Less than 1 Ω

If NG, replace the switch.

11. Rear Door Glass

A: REMOVAL

- 1) Remove the rear door trim. <Ref. to EI-43, REMOVAL, Door Trim.>
- 2) Remove the sealing cover. <Ref. to EB-23, REMOVAL, Rear Sealing Cover.>
- 3) Operate the power window switch to move the glass, and remove the two bolts.

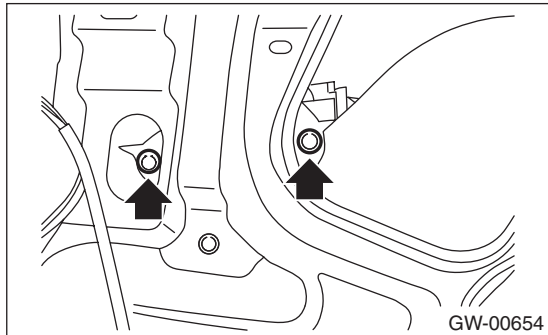

- 4) Remove the glass from the carrier plate, and gently lower the glass to the lowest position in the door panel.
- 5) Remove the glass run rubber.
- 6) Remove the bolts and nuts, and then remove the sash.

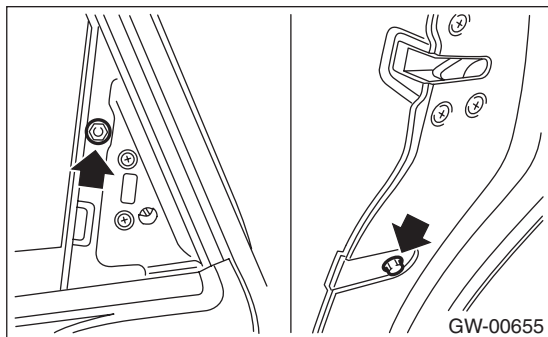

- 7) Remove the door glass while tilting the glass.

CAUTION:

Avoid impact and damage to the glass.

B: INSTALLATION

Install in the reverse order of removal.

CAUTION:

Make sure that the glass run rubber is placed securely onto the door frame and sash.

Tightening torque:

Refer to "COMPONENT" of "General Description". <Ref. to GW-5, REAR DOOR GLASS, COMPONENT, General Description.>

12. Rear Regulator and Motor Assembly

A: REMOVAL

- 1) Remove the rear door glass. <Ref. to GW-18, REMOVAL, Rear Door Glass.>
- 2) Disconnect the motor connector.
- 3) Remove the six bolts to remove the regulator assembly.

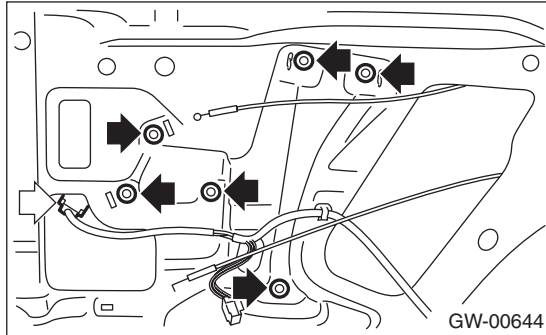

B: INSTALLATION

Install in the reverse order of removal.

Tightening torque:

Refer to “COMPONENT” of “General Description”. <Ref. to GW-5, REAR DOOR GLASS, COMPONENT, General Description.>

C: INSPECTION

- 1) Make sure that the power window motor rotates properly when the battery voltage is applied to the terminals of motor connector.
- 2) Change polarity of battery connection to terminals to ensure that the motor rotates in reverse direction.

13. Windshield Glass

A: REMOVAL

1. WHEN USING WINDSHIELD GLASS KNIFE

- 1) Remove the front pillar trim RH, and disconnect the wiper deicer connector. (Model with wiper deicer)
- 2) Remove the cowl panel. <Ref. to EI-37, REMOVAL, Cowl Panel.>
- 3) Remove the glass molding.
- 4) Tape the body side of the circumference of windshield glass for protection.
- 5) Apply sufficient amount of soapy water to the adhesive part.
- 6) Make a slit using a cutter knife to make it easier to insert the windshield glass knife.
- 7) Insert the windshield glass knife into the adhesive.

8) While holding the knife so that the blade is perpendicular to the front windshield and the edge of the glass, cut the adhesive all along the edge of the front glass.

NOTE:

- Do not twist the windshield glass knife.
- Cutting of adhesive part shall be started with wider gap between windshield glass and body.
- The locating pins are bonded to the corners of glass. Use piano wire to disconnect the pins.

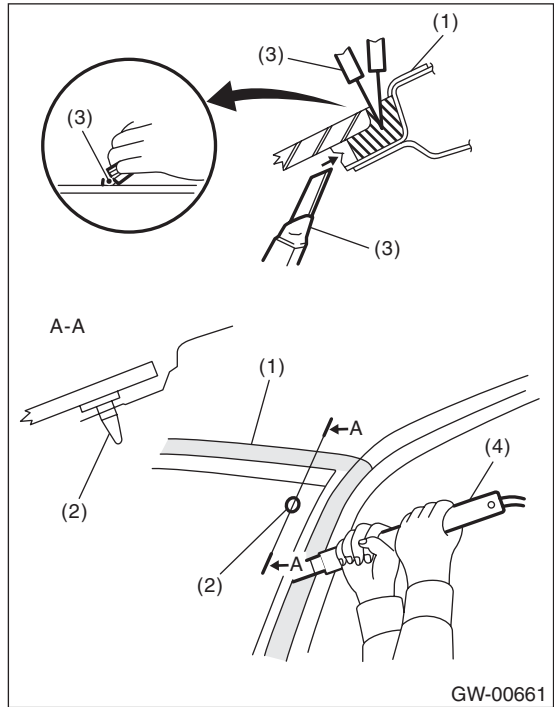

- (1) Tape for protection
- (2) Locating pin
- (3) Cutter knife
- (4) Windshield glass knife

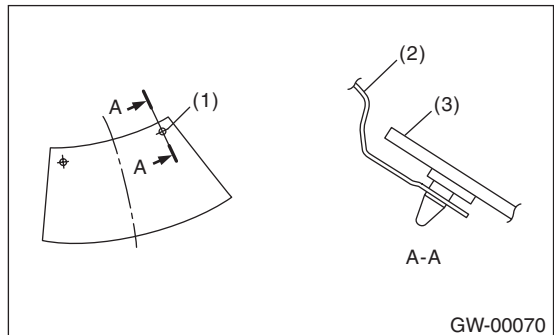

- (1) Locating pin
- (2) Body panel
- (3) Windshield glass

2. WHEN USING PIANO WIRE

- 1) Remove the front pillar trim RH, and disconnect the wiper deicer connector. (Model with wiper deicer)
- 2) Remove the cowl panel. <Ref. to EI-37, REMOVAL, Cowl Panel.>
- 3) Remove the glass molding.
- 4) Tape the body side of the circumference of windshield glass for protection.
- 5) Make a hole in the adhesive part using drill or cutter knife.
- 6) Pass the piano wire through the hole, and attach both the wire ends securely to pieces of wood.

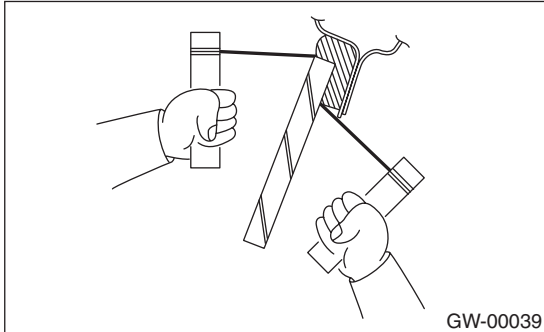

- 7) Pull the wire ends alternately to cut off the adhesive part.

CAUTION:

- Do not tightly pull the piano wire against the windshield glass edge.
- Be careful not to damage interior and exterior parts.
- When removal is made with area close to instrument panel, place a protection plate over it. Pay particular attention to the removal.
- Do not cross piano wires. Otherwise they may be cut.

B: INSTALLATION

- 1) Process the cartridge nozzle tip as shown in the figure, and set the adhesive in sealant gun.

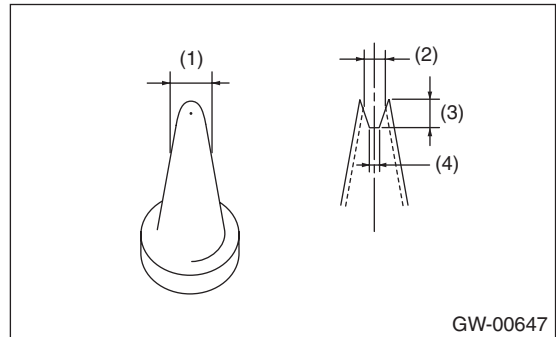

- (1) 10 mm (0.39 in)
- (2) 8 mm (0.31 in)
- (3) 9 mm (0.35 in)
- (4) 2 mm (0.08 in)

- 2) Clean the external circumference of windshield glass with alcohol or white gasoline.
- 3) Remove the adhesive layer on the body using cutter knife to obtain smooth face of 2 mm (0.08 in) thick.

CAUTION:

Be careful not to damage the body and paint surface.

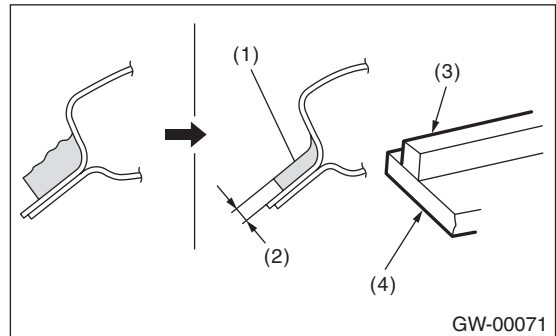

- (1) Adhesive
- (2) 2 mm (0.08 in)
- (3) Dam rubber
- (4) Glass

- 4) Clean the body with alcohol or white gasoline to eliminate cutting powder, dust and dirt completely from body.

Windshield Glass

GLASS/WINDOWS/MIRRORS

Brought to you by Eris Studios
NOT FOR RESALE

5) Install the dam rubber.

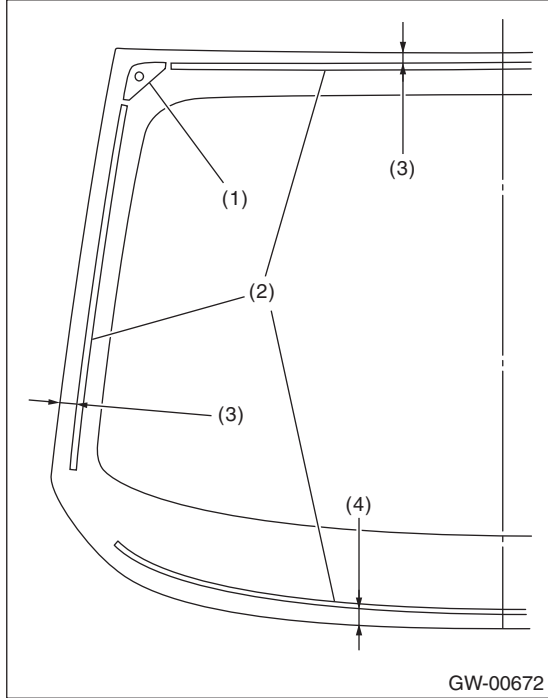

- (1) Locating pin
- (2) Dam rubber
- (3) 11 mm (0.433 in)
- (4) 13 mm (0.512 in)

6) Attach the seal to the glass. (Driver's seat side only)

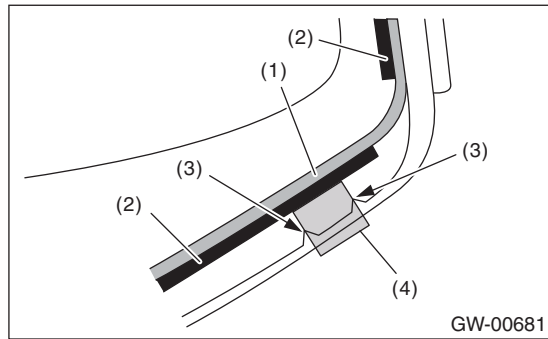

- (1) Adhesive
- (2) Dam rubber
- (3) Ceramic print cutout portion
- (4) Seal

7) Install the molding to the glass.

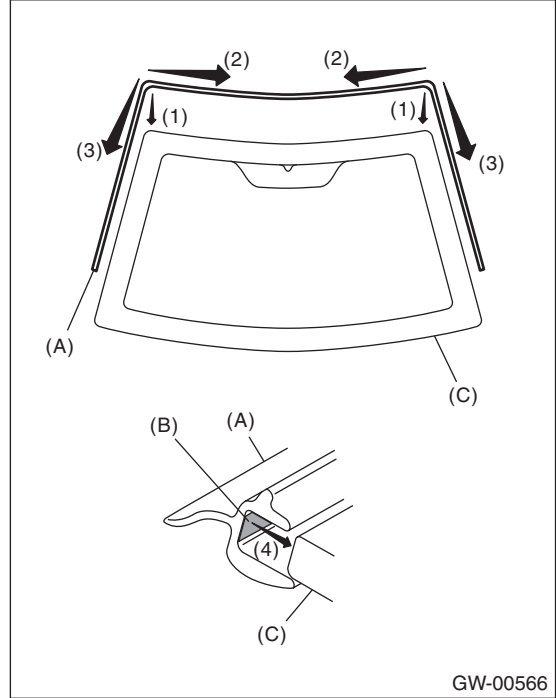

- (1) Align the molding (A) with both ends of the upper edge of the windshield glass (C).
- (2) Install the molding from both corners of the upper edge toward the center.
- (3) Install the molding from both corners of the upper edge toward the lower side.
- (4) Press the double-sided tapes (B) uniformly on both sides of the glass.

8) Apply the primer to the adhesive surfaces of glass and body sides using sponge.

Glass primer:
*Dow Automotive's
ESSEX U-401, U-402*

Painted surface primer:
*Dow Automotive's
ESSEX U-413*

NOTE:

- Primer once attached to the painted surface of the body and internal trim is hard to wipe off. Mask the circumference of such area.
- Let primer dry for about ten minutes before installing the glass.
- Do not touch the surface coated with primer.

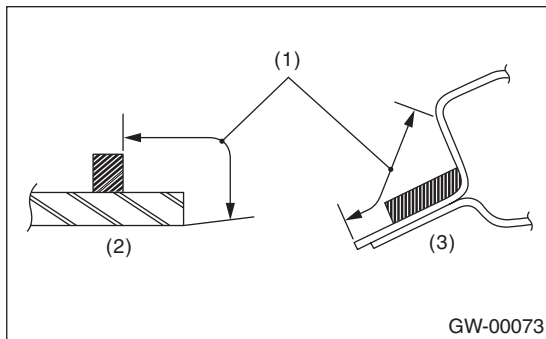

- (1) Application of primer
- (2) Glass side
- (3) Body side

9) Apply adhesive to the glass end surface as shown.

Adhesive:
*Dow Automotive's
ESSEX U-400HV or equivalent*

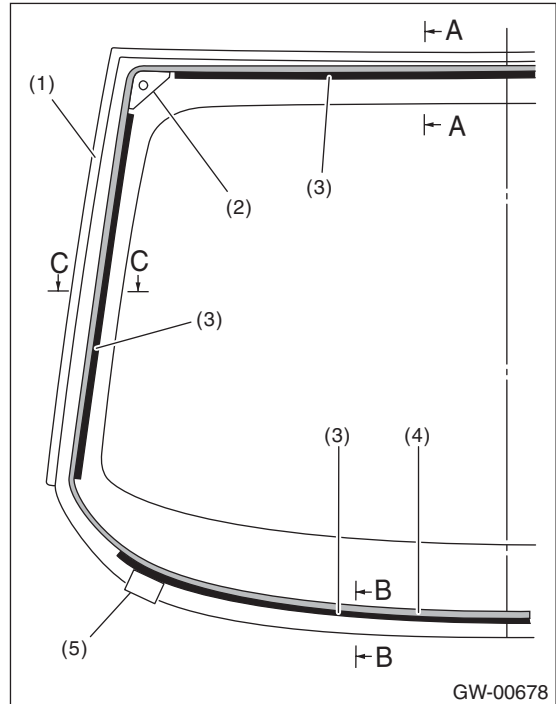

- (1) Molding
- (2) Locating pin
- (3) Dam rubber
- (4) Adhesive
- (5) Seal

Windshield Glass

GLASS/WINDOWS/MIRRORS

Brought to you by Eris Studios
NOT FOR RESALE

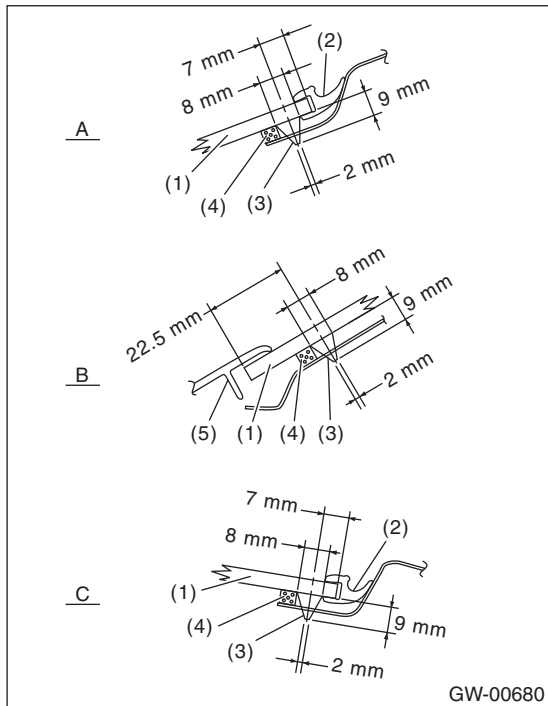

- A Upper end
- B Lower end
- C Side end

- (1) Glass
- (2) Molding
- (3) Adhesive
- (4) Dam rubber
- (5) Cowl panel

10) Fit the locating pins to vehicle body using suction rubber cup to install the windshield glass.

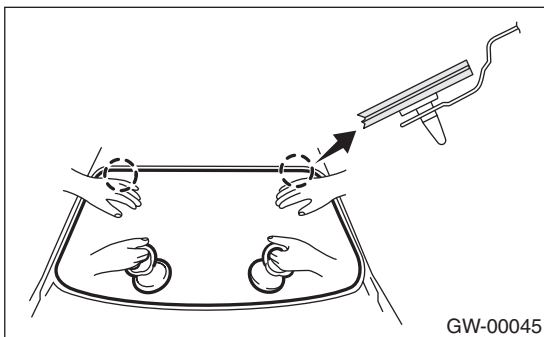

- 11) Lightly press the windshield glass for tight fit.
- 12) Make flush the adhesive surface juttred out using spatula.
- 13) Connect the wiper deicer connector. (Model with wiper deicer)

14) After completion of all work, allow the vehicle to stand for about 24 hours.

NOTE:

- When door is opened/closed after glass is bonded, always lower the door glass first, and then open/close it carefully.
- Move the vehicle slowly.
- For minimum drying time and vehicle standing time before driving after bonding, follow instructions or instruction manual from the adhesive manufacturer.

15) After curing of adhesive, pour the water on external surface of vehicle to check that there are no water leaks.

NOTE:

When a vehicle is returned to the user, tell him or her that the vehicle should not be subjected to heavy impact for at least three days.

16) Install the cowl panel. <Ref. to EI-37, INSTALLATION, Cowl Panel.>

Brought to you by Chris Studios
NOT FOR RESALE

14. Rear Gate Glass

A: REMOVAL

- 1) Remove the rear spoiler. <Ref. to EI-38, REMOVAL, Roof Spoiler.>
- 2) Remove the rear wiper motor. <Ref. to WW-18, REMOVAL, Rear Wiper Motor.>
- 3) Disconnect the electrical connectors from rear defogger terminal.
- 4) Remove the glass in the same procedure as for windshield glass. <Ref. to GW-20, REMOVAL, Windshield Glass.>

B: INSTALLATION

- 1) Apply the primer to the glass and body sides in the same procedure as for windshield glass. <Ref. to GW-21, INSTALLATION, Windshield Glass.>
- 2) Process the cartridge nozzle tip as shown in the figure, and set the adhesive in sealant gun.

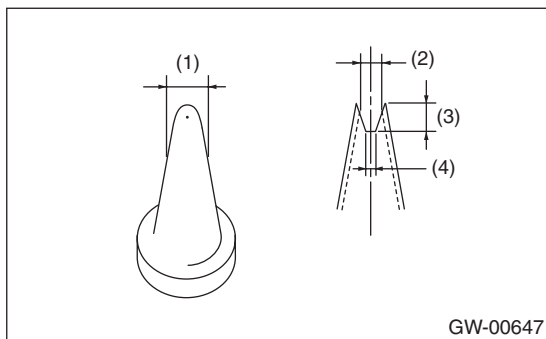

- (1) 10 mm (0.39 in)
- (2) 8 mm (0.31 in)
- (3) 10 mm (0.39 in)
- (4) 4 mm (0.16 in)

- 3) Apply adhesive in the same procedure as for windshield glass. <Ref. to GW-21, INSTALLATION, Windshield Glass.>

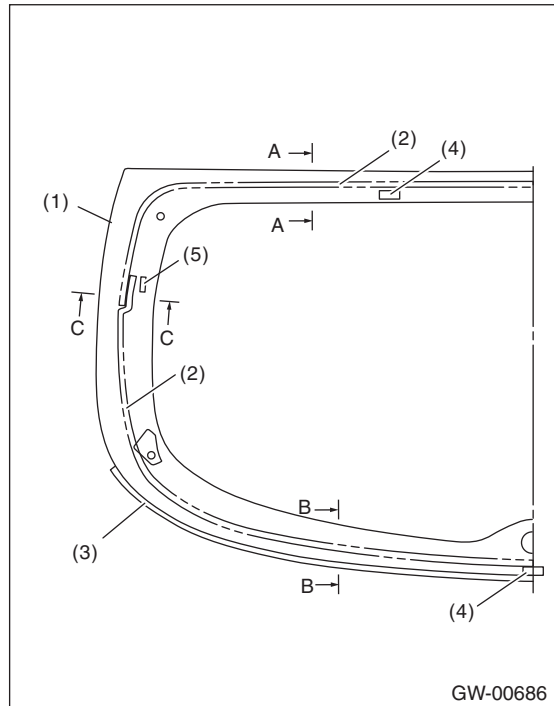

- (1) Glass
- (2) Adhesive
- (3) Molding
- (4) Spacer
- (5) Heat wire terminal

Rear Gate Glass

Brought to you by Eris Studios
NOT FOR RESALE

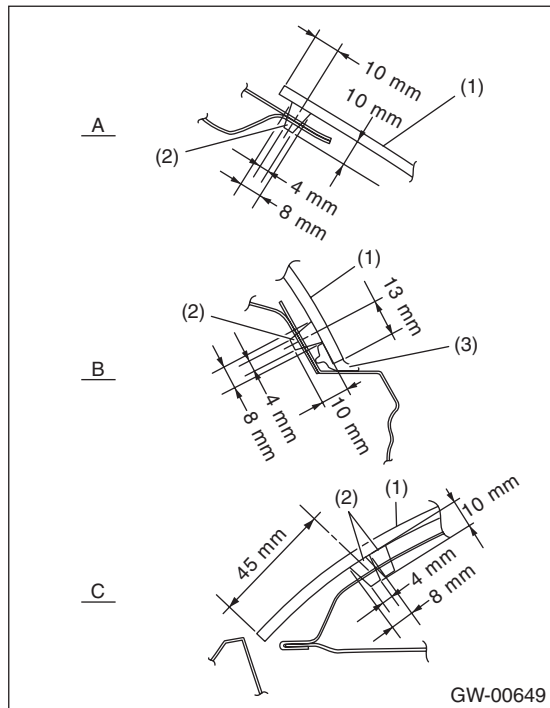

- A Upper end
- B Lower end
- C Side end

- (1) Glass
- (2) Adhesive
- (3) Molding

4) Insert the glass locating pin into the hole on rear gate panel and push on the area around the locating pin to secure it.

NOTE:

Insert the locating pin into the lower hole of the rear gate panel.

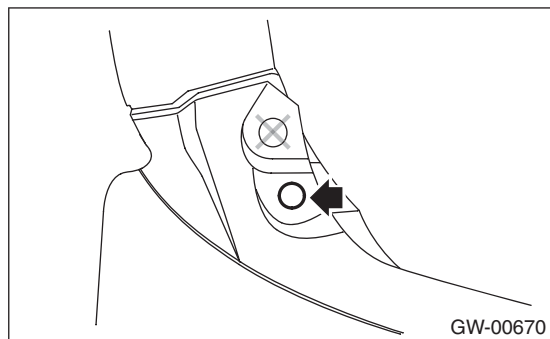

5) Push lightly all around the locating pin to seal it.
6) About one hour after installation, conduct a leak test.

7) After completion of all work, allow the vehicle to stand for about 24 hours.

NOTE:

- When door is opened/closed after glass is bonded, always lower the door glass first, and then open/close it carefully.
- Move the vehicle slowly.
- For minimum drying time and vehicle standing time before driving after bonding, follow instructions or instruction manual from the adhesive manufacturer.
- When a vehicle is returned to the user, tell him or her that the vehicle should not be subjected to heavy impact for at least three days.

8) Connect the rear defogger terminals.

9) Install the rear wiper. <Ref. to WW-18, INSTALLATION, Rear Wiper Motor.>

15. Rear Window Glass

A: REMOVAL

- 1) Disconnect the electrical connectors from rear defogger terminal.
- 2) Remove the glass in the same procedure as for windshield glass. <Ref. to GW-20, REMOVAL, Windshield Glass.>

B: INSTALLATION

- 1) Apply the primer to the glass and body sides in the same procedure as for windshield glass. <Ref. to GW-21, INSTALLATION, Windshield Glass.>
- 2) Process the cartridge nozzle tip as shown in the figure, and set the adhesive in sealant gun.

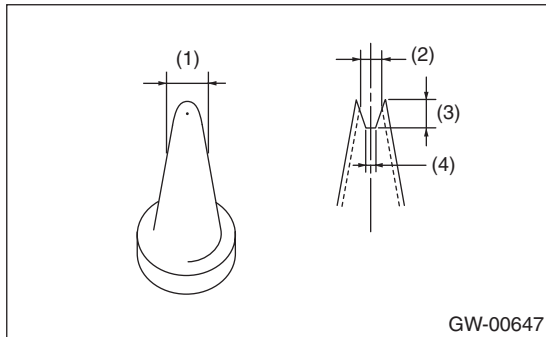

- (1) 10 mm (0.39 in)
- (2) 8 mm (0.31 in)
- (3) 9 mm (0.35 in)
- (4) 2 mm (0.08 in)

- 3) Adhere the dam rubber.

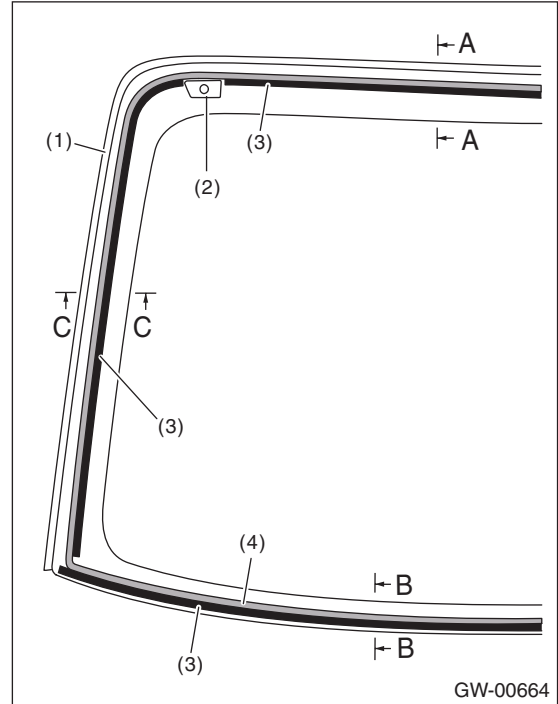

- (1) Molding
- (2) Locating pin (adhered)
- (3) Dam rubber
- (4) Adhesive

Rear Window Glass

GLASS/WINDOWS/MIRRORS

Brought to you by Eris Studios
NOT FOR RESALE

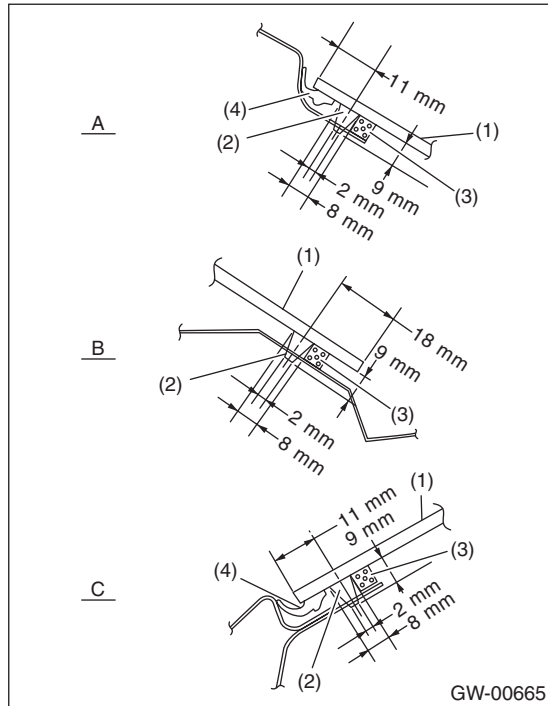

- A Upper end
- B Lower end
- C Side end

- (1) Glass
- (2) Adhesive
- (3) Dam rubber
- (4) Molding

4) Install the glass in the same procedure as for windshield glass. <Ref. to GW-21, INSTALLATION, Windshield Glass.>

5) Connect the rear defogger and antenna terminal connectors.

6) After completion of all work, allow the vehicle to stand for about 24 hours.

NOTE:

- When door is opened/closed after glass is bonded, always lower the door glass first, and then open/close it carefully.
- Move the vehicle slowly.
- For minimum drying time and vehicle standing time before driving after bonding, follow instructions or instruction manual from the adhesive manufacturer.

7) After curing of adhesive, pour the water on external surface of vehicle to check that there are no water leaks.

NOTE:

When a vehicle is returned to the user, tell him or her that the vehicle should not be subjected to heavy impact for at least three days.

16. Rear Window Defogger

A: WIRING DIAGRAM

<Ref. to WI-192, WIRING DIAGRAM, Rear Defogger System.>

B: INSPECTION

1. SYSTEM INSPECTION

Symptom	Repair order
Rear window defogger does not operate.	<ol style="list-style-type: none"> 1. Fuse (M/B No. 10) 2. Rear defogger relay 3. Defogger switch 4. Defogger wire 5. Wiring harness

2. HEAT WIRE INSPECTION

CAUTION:

When wiping off the stain on glass with cloth, use a dry and soft cloth and move it in the direction of the heat wire extension to avoid damage to the heat wire.

- 1) Turn the ignition switch to ON.
- 2) Turn the defogger switch to ON.
- 3) Wrap the tips of tester probe with aluminum foil to avoid damage to heat wire.

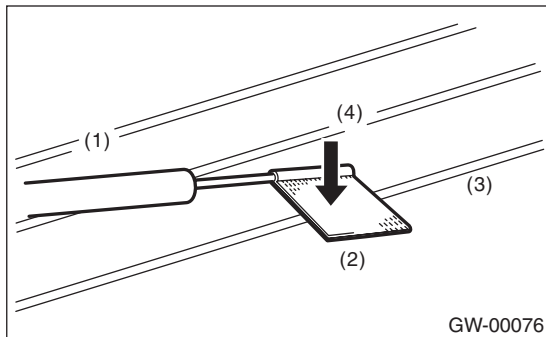

- (1) Tester probe
- (2) Aluminum foil
- (3) Heat wire
- (4) Press

- 4) Measure the voltage at heat wire center (1) with DC voltmeter.

Standard voltage:
Approx. 6 V

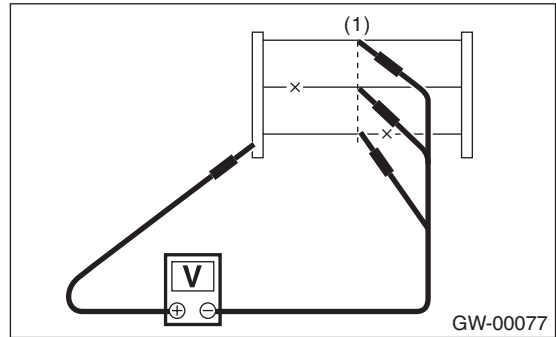

Voltage	Criteria
Approx. 6 V	OK
Approx. 12 V or 0 V	Open

NOTE:

- If the measured value is 12 V, heat wire is open between heat wire center and positive (+) terminal of tester probe.
- If it is 0 V, the circuit is open between heat wire center and ground.

5) Connect the tester probe of positive lead of voltmeter to positive terminal of heat wire and move tester probe of negative lead along the heat wire up to the negative terminal end. If voltage changes from zero to several volts during movement of tester probe, heat wire is open at the voltage change point.

C: REPAIR

- 1) Clean the broken portion with alcohol or white gasoline.
- 2) Mask both side of wire with thin film.
- 3) Apply the defogger repair compound (DUPONT No. 4817) to the broken portion.

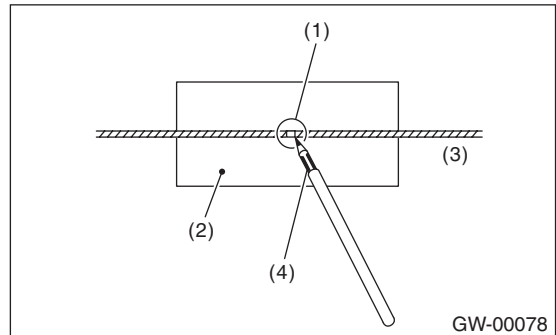

- (1) Broken portion
- (2) Thin film
- (3) Broken wire
- (4) Defogger repair compound (DUPONT No. 4817)

- 4) After repair, check the wire.

17. Rear Quarter Glass

A: REMOVAL

Remove the glass in the same procedure as for windshield glass. <Ref. to GW-20, REMOVAL, Windshield Glass.>

NOTE:

Remove the side glass of sedan model in the same procedure as for windshield glass. <Ref. to GW-20, REMOVAL, Windshield Glass.>

B: INSTALLATION

1. WAGON MODEL

- 1) Mount the fastener on the body.
- 2) Apply the primer to the glass and body sides in the same procedure as for windshield glass. <Ref. to GW-21, INSTALLATION, Windshield Glass.>
- 3) Process the cartridge nozzle tip as shown in the figure, and set the adhesive in sealant gun.

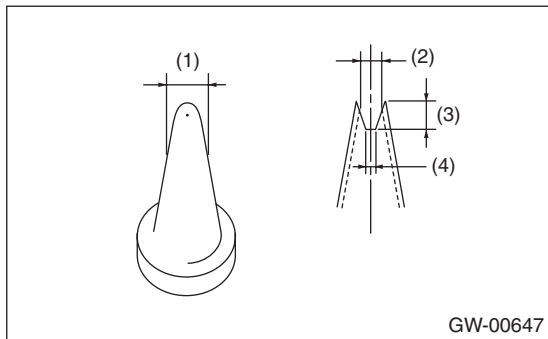

- (1) 10 mm (0.39 in)
- (2) 8 mm (0.31 in)
- (3) 9 mm (0.35 in)
- (4) 2 mm (0.08 in)

- 4) Install the dam rubber in the position 4 mm from the glass edge.

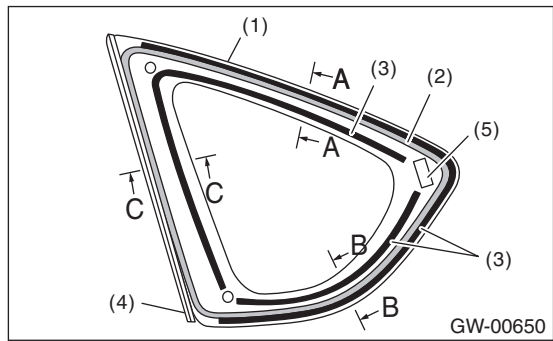

- (1) Glass
- (2) Adhesive
- (3) Dam rubber
- (4) Molding
- (5) Fastener

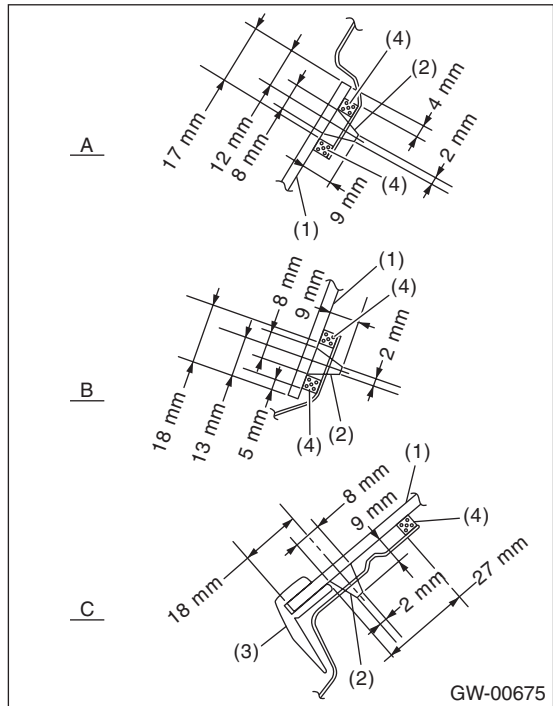

- A Upper end
- B Lower end
- C Front end

- (1) Glass
- (2) Adhesive
- (3) Molding
- (4) Dam rubber

Brought to you by
NOT FOR SALE
Chris Studios

5) Apply adhesive in the same procedure as for windshield glass. <Ref. to GW-21, INSTALLATION, Windshield Glass.>

6) Insert the glass locating pin into the hole on side panel and push on the area around the locating pin to secure it.

Then, push lightly all around the area to seal it.

7) After completion of all work, allow the vehicle to stand for about 24 hours.

NOTE:

- When door is opened/closed after glass is bonded, always lower the door glass first, and then open/close it carefully.
- Move the vehicle slowly.
- For minimum drying time and vehicle standing time before driving after bonding, follow instructions or instruction manual from the adhesive manufacturer.

8) After curing of adhesive, pour the water on external surface of vehicle to check that there are no water leaks.

NOTE:

When a vehicle is returned to the user, tell him or her that the vehicle should not be subjected to heavy impact for at least three days.

2. SEDAN MODEL

- 1) Mount the fastener on the body.
- 2) Apply the primer to the glass and body sides in the same procedure as for windshield glass. <Ref. to GW-21, INSTALLATION, Windshield Glass.>
- 3) Process the cartridge nozzle tip as shown in the figure, and set the adhesive in sealant gun.

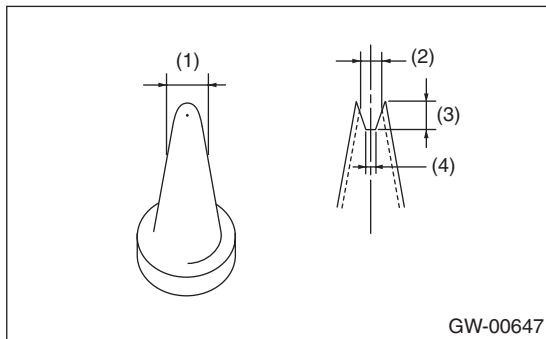

- (1) 10 mm (0.39 in)
- (2) 8 mm (0.31 in)
- (3) 9 mm (0.35 in)
- (4) 2 mm (0.08 in)

4) Install the dam rubber in the position 8 mm from the molding edge.

5) Apply adhesive in the same procedure as for windshield glass. <Ref. to GW-21, INSTALLATION, Windshield Glass.>

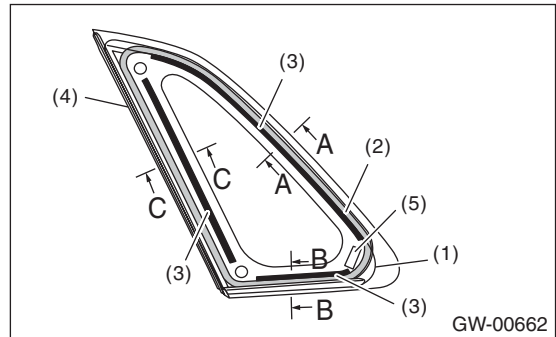

- (1) Glass
- (2) Adhesive
- (3) Dam rubber
- (4) Molding
- (5) Fastener

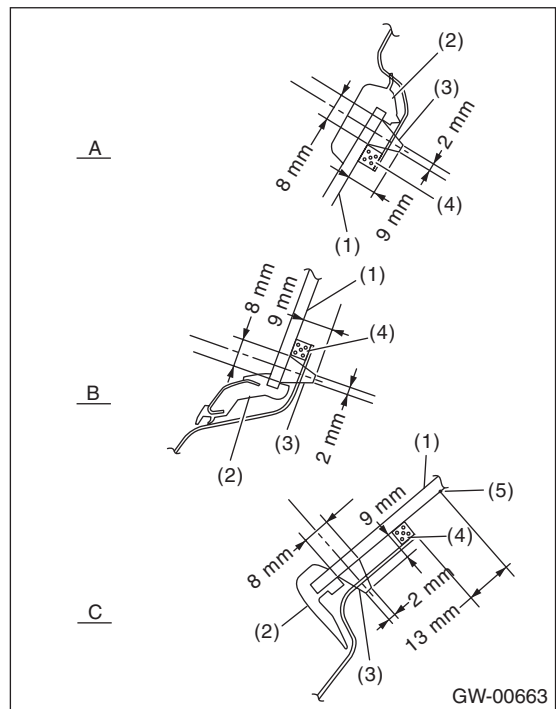

- A Upper end
- B Lower end
- C Front end

- (1) Glass
- (2) Molding
- (3) Adhesive
- (4) Dam rubber
- (5) Ceramic line edge

Rear Quarter Glass

GLASS/WINDOWS/MIRRORS

6) Insert the glass locating pin into the hole on side panel and push on the area around the locating pin to secure it.

Then, push lightly all around the area to seal it.

7) After completion of all work, allow the vehicle to stand for about 24 hours.

NOTE:

- When door is opened/closed after glass is bonded, always lower the door glass first, and then open/close it carefully.
- Move the vehicle slowly.
- For minimum drying time and vehicle standing time before driving after bonding, follow instructions or instruction manual from the adhesive manufacturer.

8) After curing of adhesive, pour the water on external surface of vehicle to check that there are no water leaks.

NOTE:

When a vehicle is returned to the user, tell him or her that the vehicle should not be subjected to heavy impact for at least three days.

18. Rearview Mirror

A: REMOVAL

NOTE:

Never reuse the spring. Prepare a new spring before removal.

1) Turn the mirror base 90° clockwise or counterclockwise to remove it.

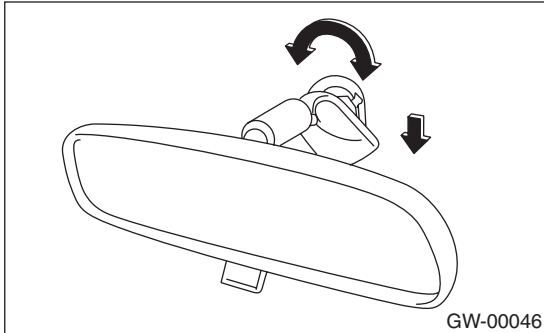

2) Remove the spring from the mirror base.

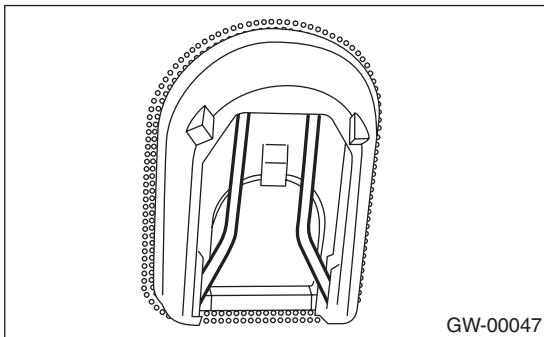

CAUTION:

Be careful not to damage the mirror surface.

3) When the mirror base is damaged, use something like piano wire or a spatula to remove.

CAUTION:

Be careful not to damage the windshield glass.

B: INSTALLATION

Install in the reverse order of removal.

NOTE:

If the mirror base is removed, install it in the following procedure.

1. Clean the old adhesive completely.
2. Align the mirror base with the mark on the windshield glass to install it.
3. Make sure the mirror base is securely attached and then install the spring to it.

Adhesive

**REPAIR KIT IN MR (Part No. 65029FC000)
or equivalent**

C: INSPECTION

- Make sure the mirror is not damaged.
- Make sure the spring is not damaged.
- Make sure the mirror base is not damaged.

19. Wiper Deicer System

A: WIRING DIAGRAM

<Ref. to WI-178, WIRING DIAGRAM, Wiper Deicer System.>

B: INSPECTION

1. SYSTEM INSPECTION

Symptoms	Repair order
Wiper deicer does not operate.	<ol style="list-style-type: none">1. Fuse (F/B No. 9)2. Fuse (F/B No. 4)3. Wiper deicer relay4. Defogger switch5. Wiper deicer wire6. Wiring harness

2. HEAT WIRE INSPECTION

Refer to "HEAT WIRE INSPECTION" of "Rear Window Defogger". <Ref. to GW-29, HEAT WIRE INSPECTION, INSPECTION, Rear Window Defogger.>

C: REPAIR

Refer to "REPAIR" of "Rear Window Defogger". <Ref. to GW-29, REPAIR, Rear Window Defogger.>