

Brought to you by Eris Studios
NOT FOR RESALE

OCCUPANT DETECTION SYSTEM (DIAGNOSTICS)

Basic Diagnostic Procedure

OCCUPANT DETECTION SYSTEM (DIAGNOSTICS)

Brought to you by Eris Studios
NOT FOR RESALE

1. Basic Diagnostic Procedure

A: PROCEDURE

	Step	Check	Yes	No
1	CHECK WARNING LIGHT. Check whether the airbag warning light in the combination meter is lit.	Does the airbag warning light illuminate?	Go to step 2.	Perform the diagnosis according to phenomenon of the problem.
2	READ DTC. 1) Turn the ignition switch to OFF. 2) Connect the Subaru Select Monitor to the data link connector. 3) Turn the ignition switch to ON and start up the Subaru Select Monitor. 4) Read the DTC. <Ref. to OD(diag)-17, OPERATION, Read Diagnostic Trouble Code (DTC).> NOTE: If the communication function of the Subaru Select Monitor cannot be executed normally, check the communication circuit. <Ref. to AB(diag)-30, COMMUNICATION FOR INITIALIZING IMPOSSIBLE, INSPECTION, Subaru Select Monitor.> 5) Record all DTCs and freeze frame data.	Is DTC displayed?	Go to step 3.	Go to "Airbag Warning Light Failure" <Ref. to AB(diag)-37, Airbag Warning Light Failure.>.
3	PERFORM DIAGNOSIS. 1) Determine the possible cause from "List of Diagnostic Trouble Code (DTC)" <Ref. to OD(diag)-22, List of Diagnostic Trouble Code (DTC).>. 2) Inspect the DTC using "List of Diagnostic Trouble Code (DTC)". 3) Repair the trouble cause. 4) Perform the Clear Memory Mode. <Ref. to OD(diag)-19, Clear Memory Mode.> 5) Perform the Inspection Mode. <Ref. to OD(diag)-18, Inspection Mode.> 6) Read any other DTCs displayed.	Is DTC displayed?	Perform the procedure 1) to 5) in step 3.	Finish the diagnosis.

Check List for Interview

OCCUPANT DETECTION SYSTEM (DIAGNOSTICS)

Brought to you by Eris Studios
NOT FOR SALE

2. Check List for Interview

A: CHECK

Customer's name		Inspector's name	
Date vehicle brought in	/ /	Registration No.	
Odometer reading	km miles	V.I.N.	
Date problem occurred	/ /	Registration year	/ /
Weather	<input type="checkbox"/> Fine <input type="checkbox"/> Cloudy <input type="checkbox"/> Rainy <input type="checkbox"/> Snowy <input type="checkbox"/> Others:		
Temperature	°C (°F)		
Road condition	<input type="checkbox"/> Flat road <input type="checkbox"/> Uphill <input type="checkbox"/> Downhill <input type="checkbox"/> Gravel road <input type="checkbox"/> Others:		
Vehicle operation	<input type="checkbox"/> Starting <input type="checkbox"/> Idling <input type="checkbox"/> Driving <input type="checkbox"/> Constant speed <input type="checkbox"/> Accelerating <input type="checkbox"/> Decelerating <input type="checkbox"/> Turning <input type="checkbox"/> Others:		
Details of problem			
Airbag warning light operation	<input type="checkbox"/> Normal (After turning the ignition switch to ON, illuminates for 6 seconds then goes off.) <input type="checkbox"/> Remains ON <input type="checkbox"/> Remains OFF		
Passenger's airbag ON/OFF indicator operation	<input type="checkbox"/> Normal (After turning the ignition switch to ON, illuminates for 6 seconds then goes off for 2 seconds; Lights ON (adult) or OFF (children/unoccupied).) <input type="checkbox"/> Both remain ON <input type="checkbox"/> Both remain OFF		
DTC output	<input type="checkbox"/> OK code <input type="checkbox"/> DTC: (Code:)		

General Description

OCCUPANT DETECTION SYSTEM (DIAGNOSTICS)

Brought to you by Eris Studios
NOT FOR RESALE

3. General Description

A: CAUTION

1) If the seat cushion cover is removed or replaced, make sure to perform passenger detection system adjustment after installing the seat to the vehicle. <Ref. to OD(diag)-15, SYSTEM CALIBRATION (REZEROING), OPERATION, Subaru Select Monitor.>

Failure to do so may cause improper operation of the passenger detection system.

2) The passenger detection system (passenger seat only) control unit and the passenger detection sensor are fixed to the seat cushion frame. Never remove the passenger detection control unit or the pressure sensor from the seat cushion frame.

3) Do not replace the seat cushion pad by itself. Always replace the seat cushion pad and frame assembly as a set. The seat cushion pad and cushion frame are adjusted as a set at the time of manufacture. If cushion pads and cushion frames are combined from those of other vehicles or other sets, the passenger detection system may not operate properly.

4) If the seat cushion cover is removed, make sure to replace the hang wire on the seat cushion side with a new wire.

5) Never connect the battery in reverse polarity. Occupant detection system may be destroyed instantly.

6) Do not disconnect the battery terminals while the engine is running.

A large counter electromotive force will be generated in the generator, and this voltage may damage electronic parts such as occupant detection control module.

7) Before disconnecting the connectors of each sensor and control module, be sure to turn the ignition switch to OFF and wait for 20 seconds or more. Occupant detection control module may be damaged.

8) All passenger detection system parts are precision components. Do not drop them.

CAUTION:

- Do not use electrical test equipment on the airbag system wiring harness and connector circuit.
- Be careful not to damage the airbag system wiring harness when servicing the occupant detection system.
- Refer to Airbag System when repairing the occupant detection system. <Ref. to AB(diag)-4, CAUTION, General Description.>

B: INSPECTION

Measure the battery voltage and check electrolyte.

Standard voltage:

12 V

Specific gravity:

1.260 or more

Fluid level:

Between the upper level and lower level

General Description

OCCUPANT DETECTION SYSTEM (DIAGNOSTICS)

Brought to you by Eris Studios
NOT FOR SALE

C: PREPARATION TOOL

CAUTION:

To measure the voltage and resistance of airbag system and occupant detection system components, be sure to use the specified test harness.

1. SPECIAL TOOL

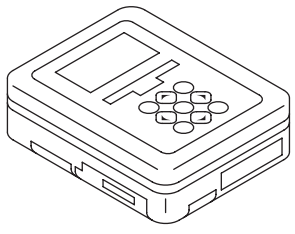
ILLUSTRATION	TOOL NUMBER	DESCRIPTION	REMARKS
 <p>ST1B021XU0</p>	1B021XU0	SUBARU SELECT MONITOR III KIT	Used for troubleshooting the electrical system.

• TEST HARNESS D

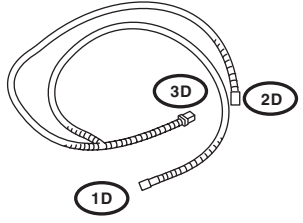
ILLUSTRATION	TOOL NUMBER	DESCRIPTION	REMARKS
 <p>ST98299AG060</p>	98299AG060	TEST HARNESS D	Used when measuring voltage and resistance of the front seat belt buckle switch.

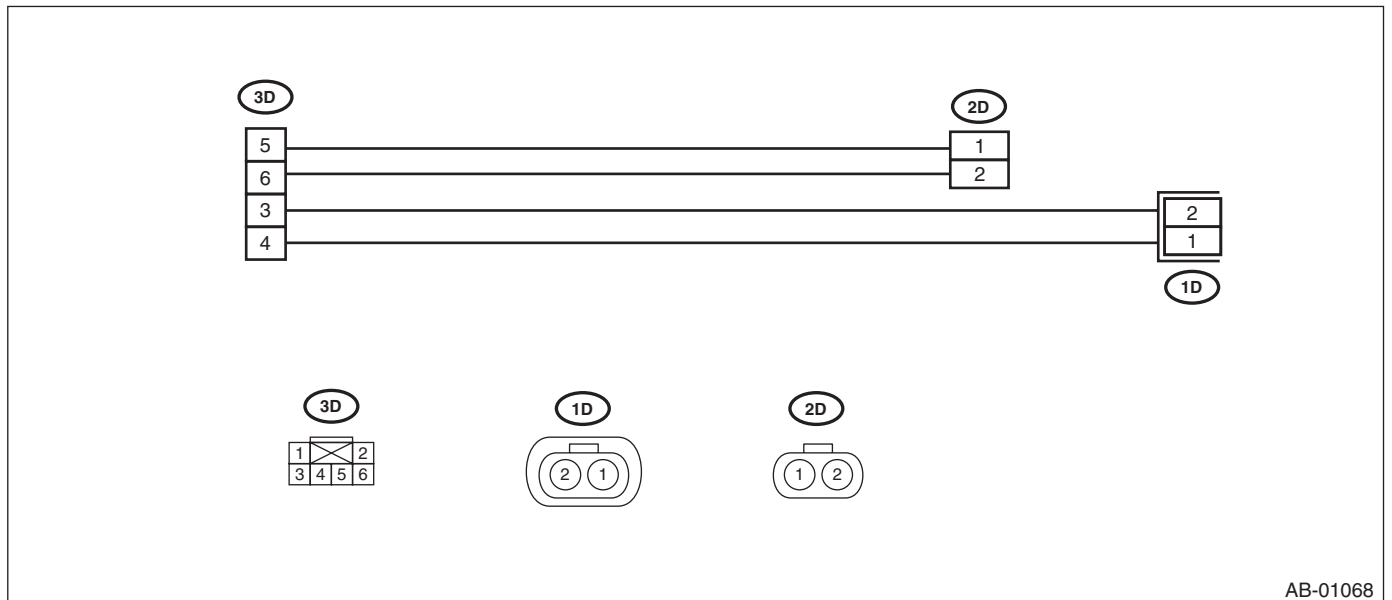

AB-01068

General Description

OCCUPANT DETECTION SYSTEM (DIAGNOSTICS)

Brought to you by Eris Studios
NOT FOR RESALE

- TEST HARNESS Y

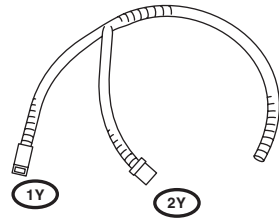
ILLUSTRATION	TOOL NUMBER	DESCRIPTION	REMARKS
 <p>ST98299AG040</p>	98299AG040	TEST HARNESS Y	Used for diagnosing seat belt buckle switch.

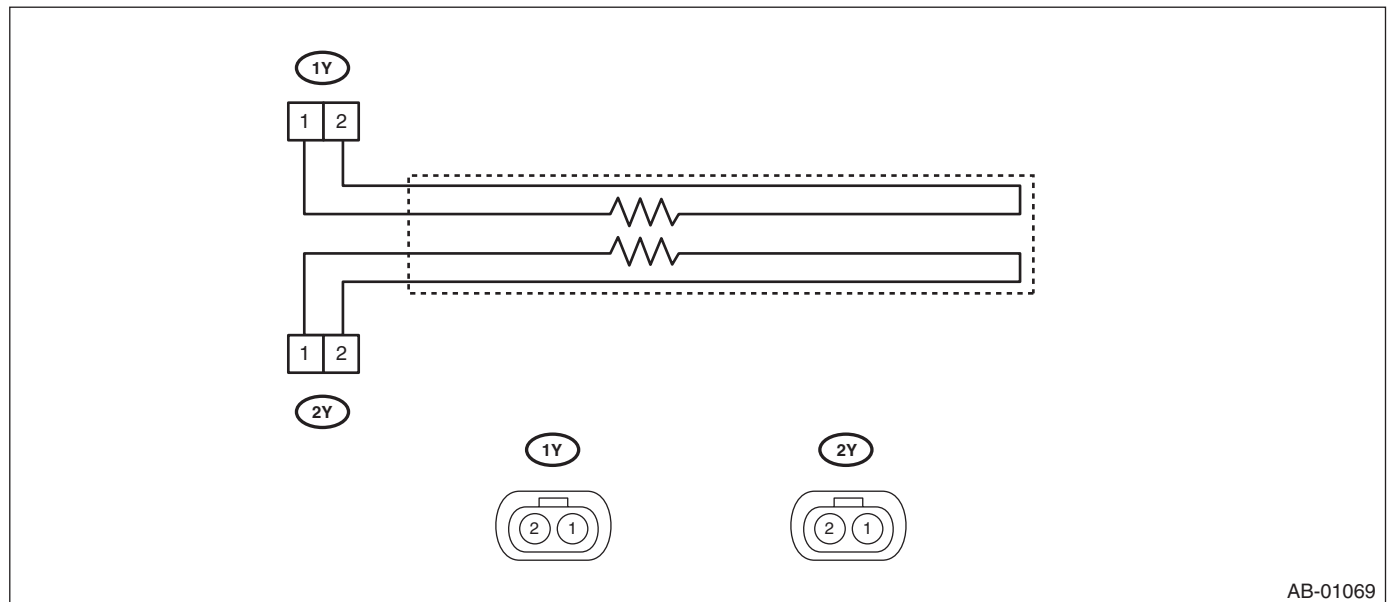

General Description

OCCUPANT DETECTION SYSTEM (DIAGNOSTICS)

Brought to you by Eris Studios
NOT FOR SALE

- TEST HARNESS AB

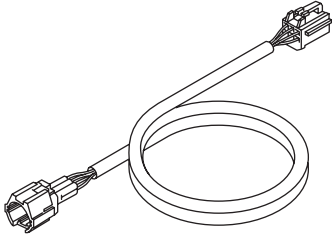
ILLUSTRATION	TOOL NUMBER	DESCRIPTION	REMARKS
 <p>ST98299XA000</p>	98299XA000	TEST HARNESS AB	Used when measuring voltage and resistance of occupant detection system.

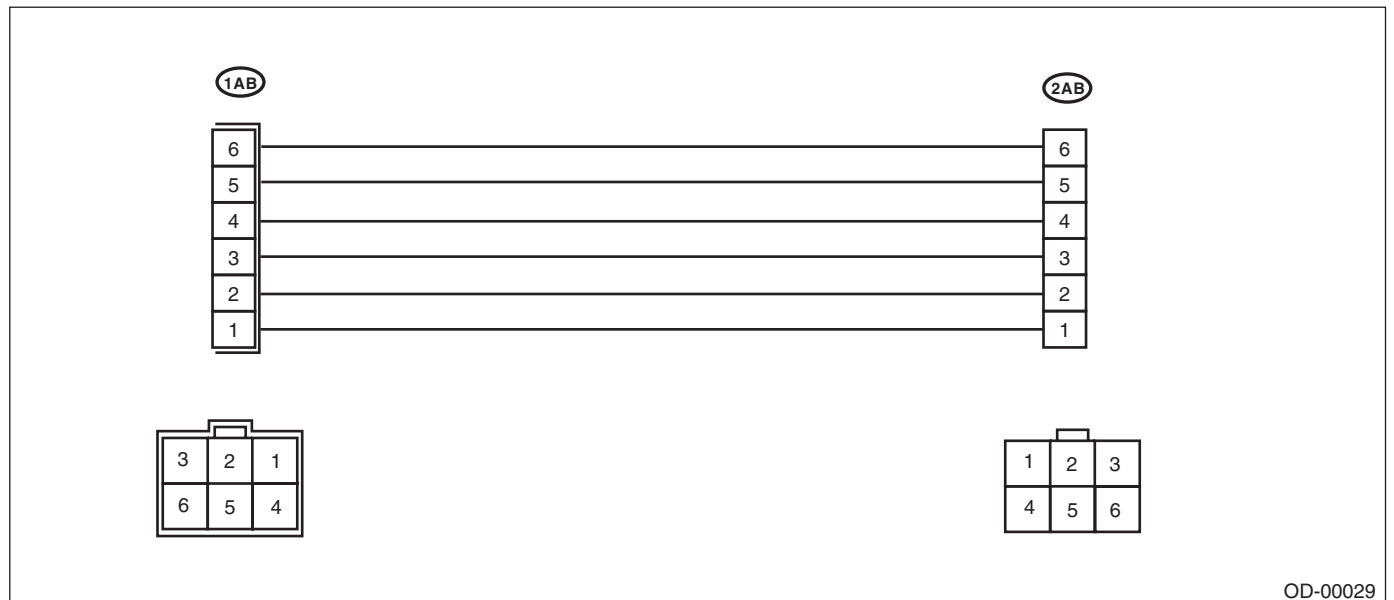

OD-00029

General Description

Brought to you by Eris Studios
NOT FOR RESALE

OCCUPANT DETECTION SYSTEM (DIAGNOSTICS)

- TEST HARNESS AE

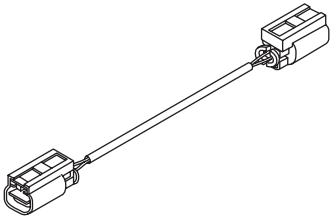
ILLUSTRATION	TOOL NUMBER	DESCRIPTION	REMARKS
 ST98299XA030	98299XA030	TEST HARNESS AE	TEST HARNESS Y adapter harness Used for diagnosing seat belt buckle switch.

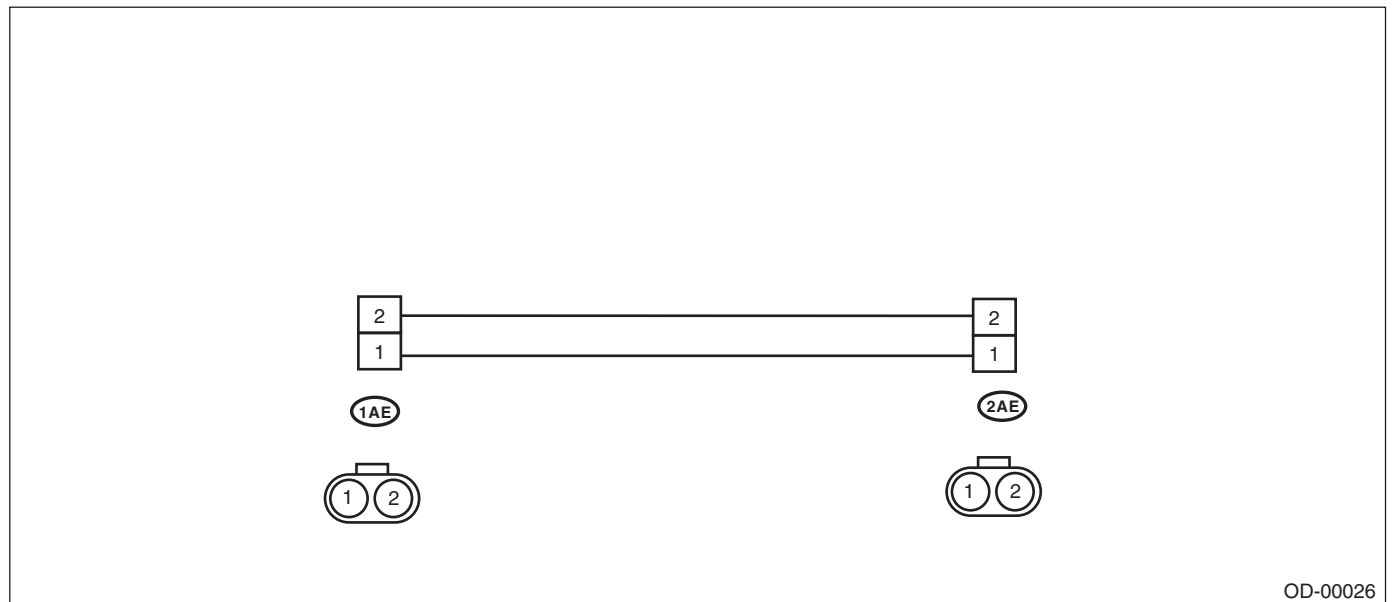

General Description

OCCUPANT DETECTION SYSTEM (DIAGNOSTICS)

Brought to you by Eriss Studios
NOT FOR SALE

- TEST HARNESS AC

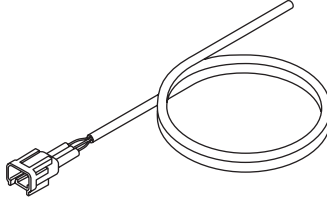
ILLUSTRATION	TOOL NUMBER	DESCRIPTION	REMARKS
 ST98299XA010	98299XA010	TEST HARNESS AC	Used for diagnosing the seat belt tension sensor.

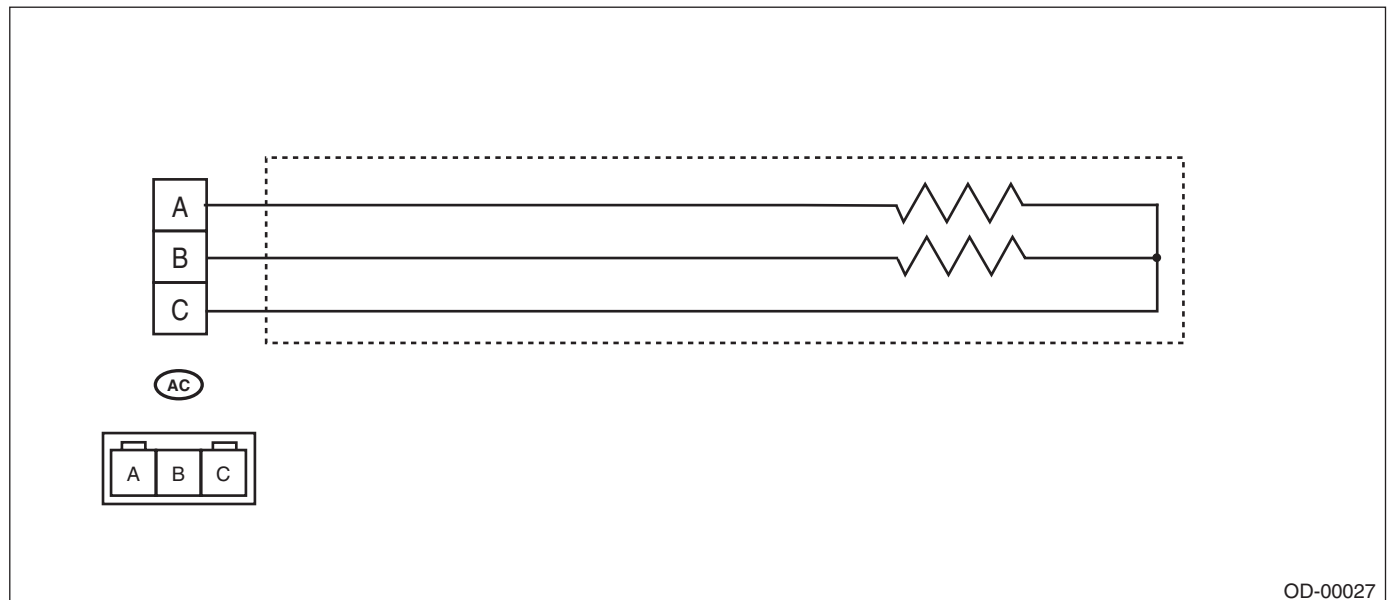

General Description

Brought to you by Eris Studios
NOT FOR RESALE

OCCUPANT DETECTION SYSTEM (DIAGNOSTICS)

• TEST HARNESS AD

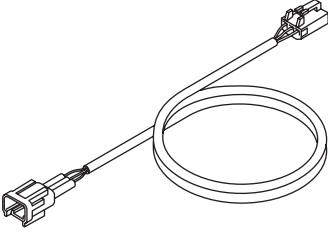
ILLUSTRATION	TOOL NUMBER	DESCRIPTION	REMARKS
 <p>ST98299XA020</p>	98299XA020	TEST HARNESS AD	Used when measuring voltage and resistance of the seat belt tension sensor.

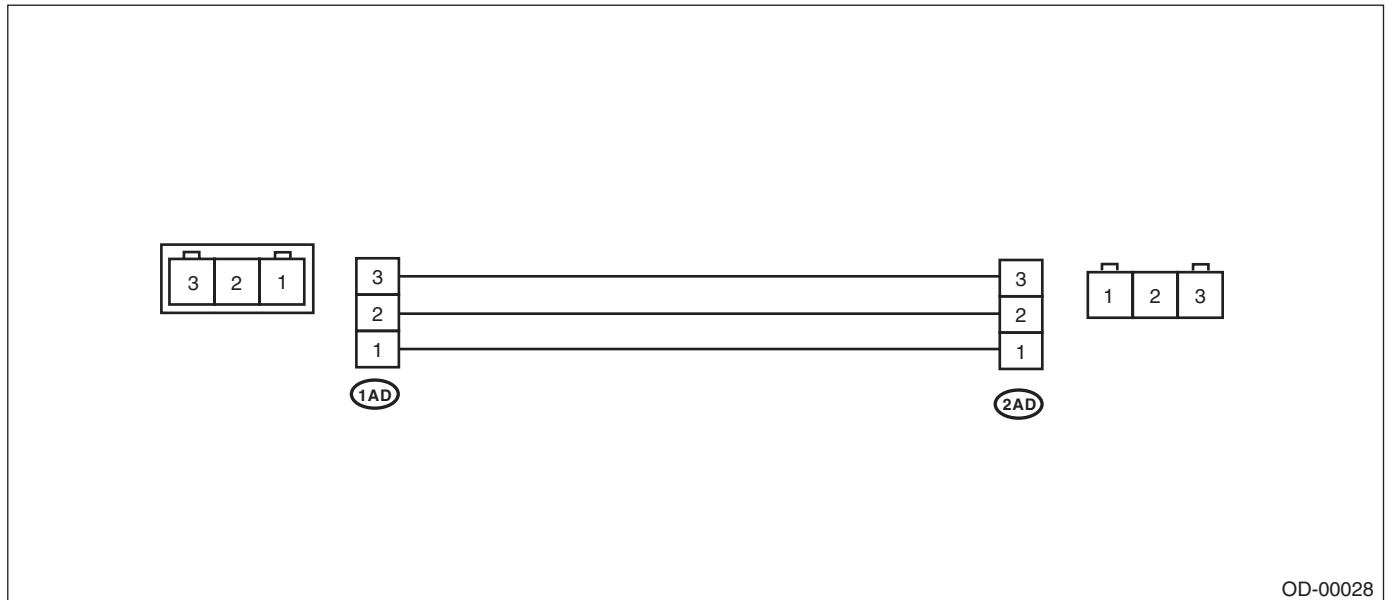

2. GENERAL TOOL

TOOL NAME	REMARKS
Circuit tester	Used for measuring resistance, voltage and current.

Electrical Component Location

OCCUPANT DETECTION SYSTEM (DIAGNOSTICS)

Brought to you by Eris Studios
NOT FOR SALE

4. Electrical Component Location

A: LOCATION

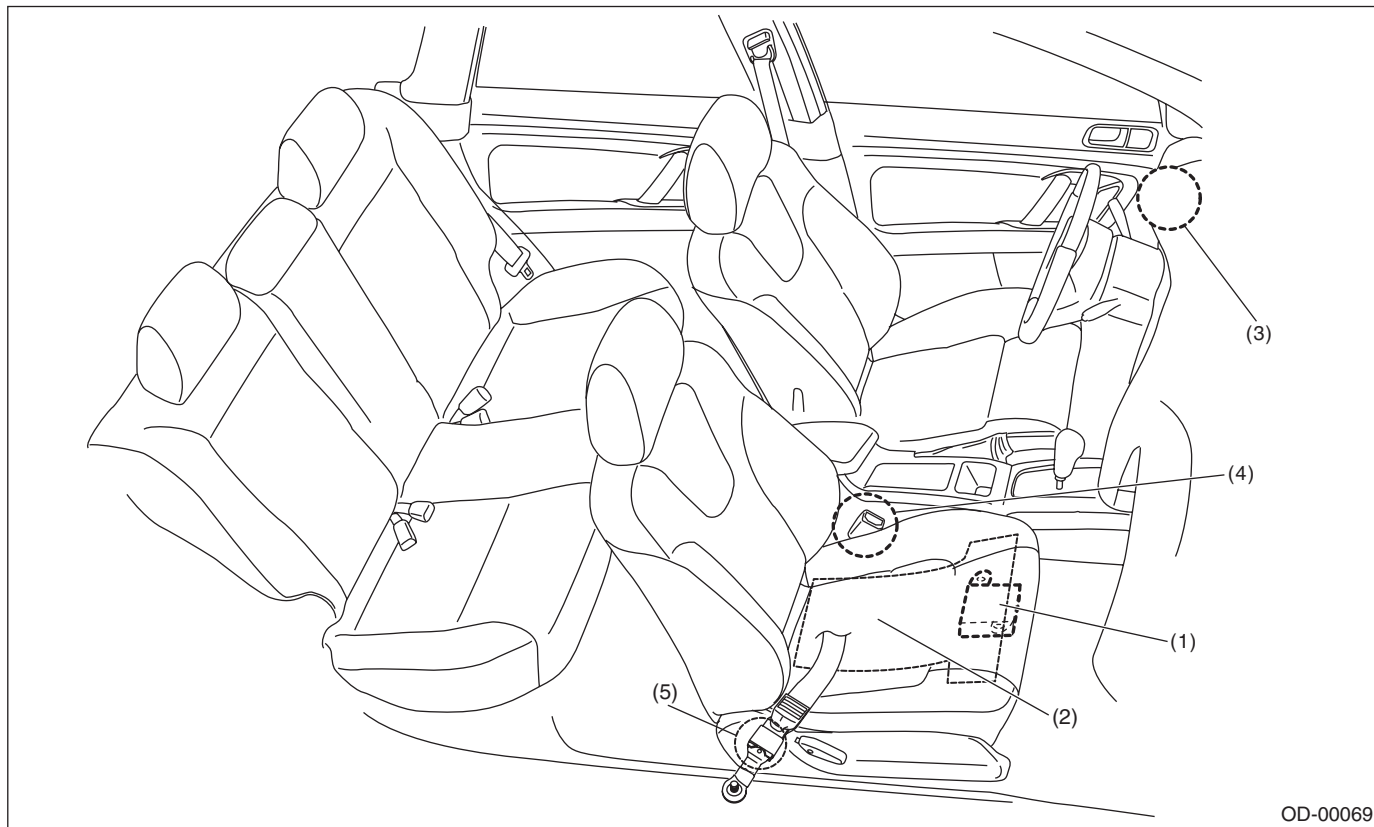

- (1) Occupant detection control module
- (2) Occupant detection sensor
- (3) Airbag ON/OFF indicator light
- (4) Buckle switch (Passenger's seat)
- (5) Seat belt tension sensor

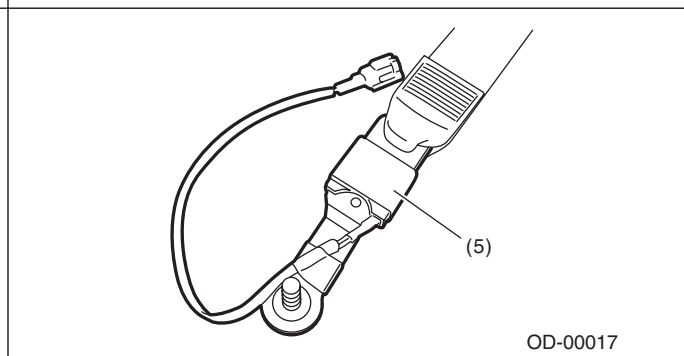
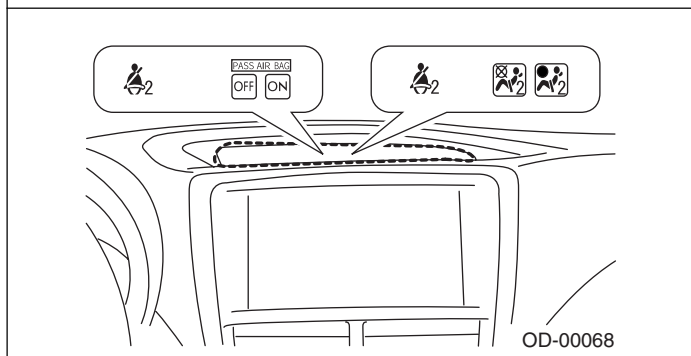
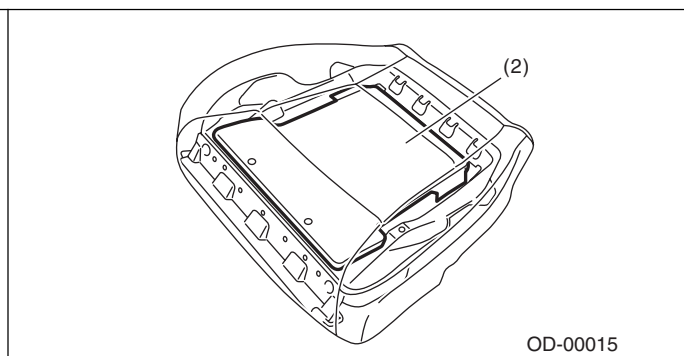
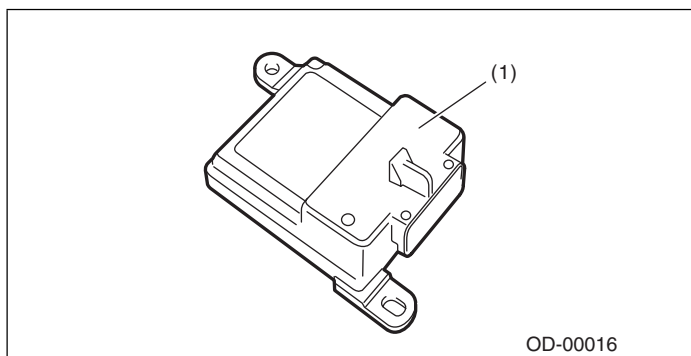

Airbag Connector

OCCUPANT DETECTION SYSTEM (DIAGNOSTICS)

Brought to you by Eris Studios
NOT FOR RESALE

5. Airbag Connector

A: PROCEDURE

1. BUCKLE SWITCH

1) How to disconnect:

- (1) Move the slide lock (A) in the direction of arrow.
- (2) While holding the slide lock (A) in the moved position, disconnect the connector.

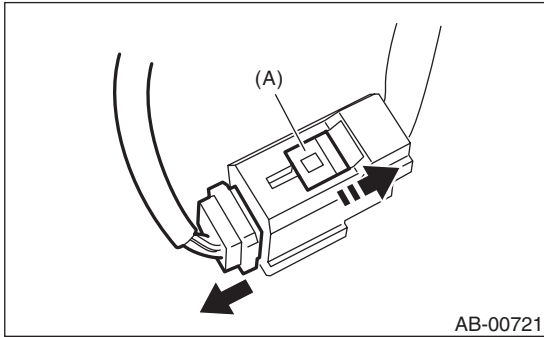

CAUTION:

When pulling the slide lock or disconnecting connector, be sure to hold the connector, not the harness.

2) How to connect:

Holding the connector (A), and push it in carefully until a clicking sound is heard.

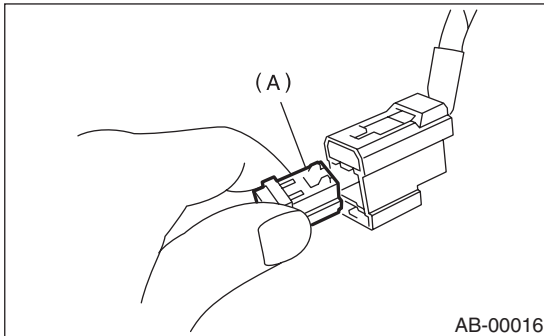

CAUTION:

Be sure to insert the connector in until it is locked. Then pull it gently to make sure that it is locked.

Control Module I/O Signal

OCCUPANT DETECTION SYSTEM (DIAGNOSTICS)

Brought to you by Eris Studios
NOT FOR SALE

6. Control Module I/O Signal

A: ELECTRICAL SPECIFICATION

CAUTION:

Never remove the occupant detection control module, occupant detection sensor or seat frame because they are integrated into one unit.

Terminal name	Terminal No.	Input/Output value	Remarks	
IG – power supply	9	9 — 16 V	When ignition switch ON	
Airbag control module communication (COM)	10	Open collector terminal	Communication line	
Airbag control module communication (GND)	5	0 V	Ground	
Belt tension sensor	(Vcc)	4	0 — 5 V	Belt tension sensor power supply
	(Vout)	16	0.5 — 4.5 V	Sensor output voltage
	(GND)	14	0 V	Sensor ground
Occupant detection sensor	(Vcc)	6	0 — 5 V	Pressure sensor power supply
	(Vout)	7	0.5 — 4.5 V	Sensor output voltage
	(GND)	15	0 V	Sensor ground
Buckle switch	1	0 — IG voltage	Ignition voltage when switch ON	
Buckle switch (GND)	2	0 V	Switch ground	

B: WIRING DIAGRAM

Refer to the electrical wiring diagram. <Ref. to WI-154, WIRING DIAGRAM, Occupant Detection.>

7. Subaru Select Monitor

A: OPERATION

1. READ DIAGNOSTIC TROUBLE CODE (DTC)

When malfunction of the airbag system and the occupant detection system occur, the DTC stored in airbag control module will be read out.

Refer to the DTC readout of the airbag system (diagnosis). <Ref. to AB(diag)-28, READ DIAGNOSTIC TROUBLE CODE (DTC), OPERATION, Subaru Select Monitor.>

NOTE:

- For details concerning the operation procedure, refer to the “PC Application Help for Subaru Select Monitor”.
- For details concerning DTCs, refer to the List of Diagnostic Trouble Code (Airbag system, Occupant detection system). <Ref. to AB(diag)-42, List of Diagnostic Trouble Code (DTC).> <Ref. to OD(diag)-22, List of Diagnostic Trouble Code (DTC).>

2. DISPLAY OF STATUS INFORMATION

Check the operating condition of each sensor in the event of malfunction in the seat belt buckle switch and seat position sensor, or when the seat belt buckle switch and seat position sensor has been replaced.

- 1) Select {Each System Check} in «Main Menu».
- 2) On the «System Selection Menu» display screen, select the {Airbag System}.
- 3) On the «Airbag System» display screen, select the {Status Data}.

The following table is for support data.

Contents	Display Contents
Seat position sensor LH	—*5
Seat position sensor RH	—*5
Seat belt buckle switch LH	—*9
Seat belt buckle switch RH	Belted *6/Unbelted*7 /Other *8/Initial Setting *4 /—*9
Passenger's airbag control status	ON *10/OFF *11 /Initial Setting *4

- *1: The seat position is forward.
- *2: The seat position is rearward.
- *3: Displayed when data other than before and behind the seat, such as the breakdown etc, is input.
- *4: Displayed when it is initial.
- *5: Seat position sensor not supported
- *6: Seat belt fastened
- *7: Seat belt not fastened
- *8: Displayed when data other than belt fastened or not fastened, such as breakdowns is input.
- *9: Seat belt buckle switch not supported
- *10: Passenger's airbag operating state
- *11: Passenger's airbag non-operating state

NOTE:

For details concerning the operation procedure, refer to the “PC Application Help for Subaru Select Monitor”.

Brought to you by Eris Studios
NOT FOR SALE

3. CLEAR MEMORY MODE

Clear the DTC stored in the airbag control module after repairing the airbag system and occupant detection system. (After the breakdown is recovered, the breakdown code for completed recoveries are read out when the next breakdown occurs if the memory clear work is not performed.)

- 1) Select {Each System Check} in «Main Menu».
- 2) On the «System Selection Menu» display screen, select the {Airbag System}.
- 3) On the «Airbag System» display screen, select the {Clear Memory}.
- 4) When the Clear Memory? is shown on the screen, select the [OK].
- 5) When “Done” is displayed, terminate the Subaru Select Monitor and turn the ignition switch to OFF.

NOTE:

For details concerning the operation procedure, refer to the “PC Application Help for Subaru Select Monitor”.

4. SYSTEM CALIBRATION (REZEROING)

NOTE:

When replacing the occupant detection system, or removing and disassembling the passenger’s seat, always perform the system calibration after installing a seat in the vehicle.

CAUTION:

When the trouble occurs in the system during calibration process, “Occupant detection calibration failure” is detected in the DTC 2A of the airbag system and the airbag warning light lights. In this case, after turning the ignition switch to OFF once, redo the system calibration (Rezeroing), or after clearing the cause of the failure, perform the system calibration again.

- 1) Park empty vehicle on a level surface.
- 2) Select {Each System Check} in «Main Menu».
- 3) On the «System Selection Menu» display screen, select the {Occupant Detection System}.
- 4) On the «Occupant Detection System» display screen, select the {Zero Point Adjustment}.
- 5) «See service manual. And check vehicle condition for successfully completing the rezeroing» is displayed. Check the following to adjust the condition of the vehicle.
 - Adjust the seat backrest to be fully upright. (For models with power seats, press the power seat button until the backrest comes to a stop.)
 - Adjust the seat slide position all the way back. (For models with power seats, press the power seat button until the seat slide does not move any further.)
 - Do not place anything on the top of the seat cushion.
 - Sit on the seat cushion to smooth the seat surface.
 - Check that the passenger’s seat belt is not inserted into the buckle, not tense or not stuck.
 - Check that ambient temperature is in a range from 0 to 40°C.
- 6) When the «Re-zeroing Adjust the passenger seat to the condition shown in service manual» is displayed, slide the passenger seat all the way to the back, check that the backrest is adjusted to all the way up, and select the [OK].

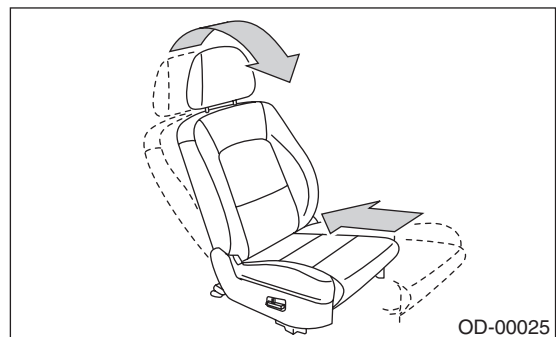

7) When the «Re-zeroing Unbelt the Passenger seatbelt Continue: OK, Quit: NO» is displayed, make sure the passenger's seatbelt is disconnected from the buckle and select the [OK].

8) When the «Re-zeroing Empty the passenger seat Continue: OK, Quit: NO» is displayed, make sure that the passenger's seat is empty, airbag OFF indicator illuminates and airbag ON indicator does not illuminate, and select the [OK].

NOTE:

- After selecting the [OK], Now «processing... Wait for a while. Do not touch or give impact to vehicle and seat» is displayed. Do not touch or rock the vehicle while the message is displayed.

- During the system calibration process, if the «Re-zeroing is unsuccessful See service manual Press OK to END» is displayed, go to step 10).

9) When the «Re-zeroing is ended normally, the Re-zeroing is successfully completed Press OK to END» is displayed. and then turn the ignition switch to OFF to finish the diagnosis.

10) During the system calibration process, if «Re-zeroing is unsuccessful See service manual Press OK to END» is displayed, turn the ignition switch to OFF once and turn it ON again, then read the DTC of the airbag system. <Ref. to AB(diag)-28, READ DIAGNOSTIC TROUBLE CODE (DTC), OPERATION, Subaru Select Monitor.>

When DTC is input, fix the fault and then perform the system calibration. When DTC is not input, check the seat and vehicle status and then perform the system calibration again. <Ref. to OD(diag)-15, SYSTEM CALIBRATION (REZEROING), OPERATION, Subaru Select Monitor.>

NOTE:

When the re-zeroing is unsuccessful, there could be occupant detection system failure or improper seat and vehicle status. When the airbag warning light illuminates, read the DTC of the airbag system, and perform the diagnosis while referring to List of Diagnostic Trouble Code. <Ref. to AB(diag)-28, READ DIAGNOSTIC TROUBLE CODE (DTC), OPERATION, Subaru Select Monitor.> <Ref. to AB(diag)-42, LIST, List of Diagnostic Trouble Code (DTC).>

B: INSPECTION

1. COMMUNICATION FOR INITIALIZING IMPOSSIBLE

DETECTING CONDITION:

Defective harness connector

TROUBLE SYMPTOM:

Communication is impossible between the airbag control module and the Subaru Select Monitor.

Refer to "Initial Communication Impossible" in the DTC of the airbag system (diagnosis). <Ref. to AB(diag)-30, COMMUNICATION FOR INITIALIZING IMPOSSIBLE, INSPECTION, Subaru Select Monitor.>

2. WITHOUT DTC

DETECTING CONDITION:

- Defective combination meter
- Open circuit of harness

TROUBLE SYMPTOM:

- Airbag warning light remains on.
- "NO TROUBLE CODE" will be displayed on the Subaru Select Monitor.

NOTE:

- For detailed operation procedures, refer to "Airbag Warning Light Failure". <Ref. to AB(diag)-37, Airbag Warning Light Failure.>

- When the airbag warning light is OFF and "NO TROUBLE CODE" is displayed on Subaru Select Monitor, the system is operating properly.

Read Diagnostic Trouble Code (DTC)

OCCUPANT DETECTION SYSTEM (DIAGNOSTICS)

8. Read Diagnostic Trouble Code (DTC)

A: OPERATION

For details on reading DTCs, refer to “Airbag System (Diagnosis) Subaru Select Monitor”. <Ref. to AB(diag)-28, Subaru Select Monitor.>

Brought to you by Eris Studios
NOT FOR SALE

Inspection Mode

OCCUPANT DETECTION SYSTEM (DIAGNOSTICS)

Brought to you by Eris Studios
NOT FOR RESALE

9. Inspection Mode

A: PROCEDURE

Recreate the circumstance by referring to the conditions described in the checklist.

10. Clear Memory Mode

A: OPERATION

- Clear the memory in the following steps after the malfunction is repaired.
- For details to clear the DTC, refer to “Airbag System (Diagnosis) Subaru Select Monitor”. <Ref. to AB(diag)-28, Subaru Select Monitor.>

Airbag Warning Light Illumination Pattern

OCCUPANT DETECTION SYSTEM (DIAGNOSTICS)

Brought to you by Eris Studios
NOT FOR RESALE

11. Airbag Warning Light Illumination Pattern

A: INSPECTION

Turn the ignition switch to ON, and confirm that the airbag warning light remains on for approx. 6 seconds and then goes off afterwards.

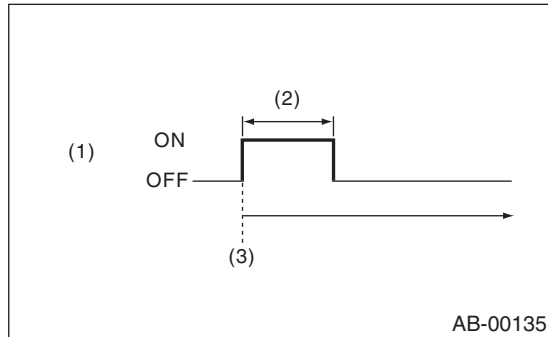

- (1) Airbag warning light
- (2) Approx. 6 sec.
- (3) Ignition switch ON

Passenger's Airbag ON/OFF Indicator Light Illumination Pattern

OCCUPANT DETECTION SYSTEM (DIAGNOSTICS)

Brought to you by Eris Studios
NOT FOR SALE

12. Passenger's Airbag ON/OFF Indicator Light Illumination Pattern

A: INSPECTION

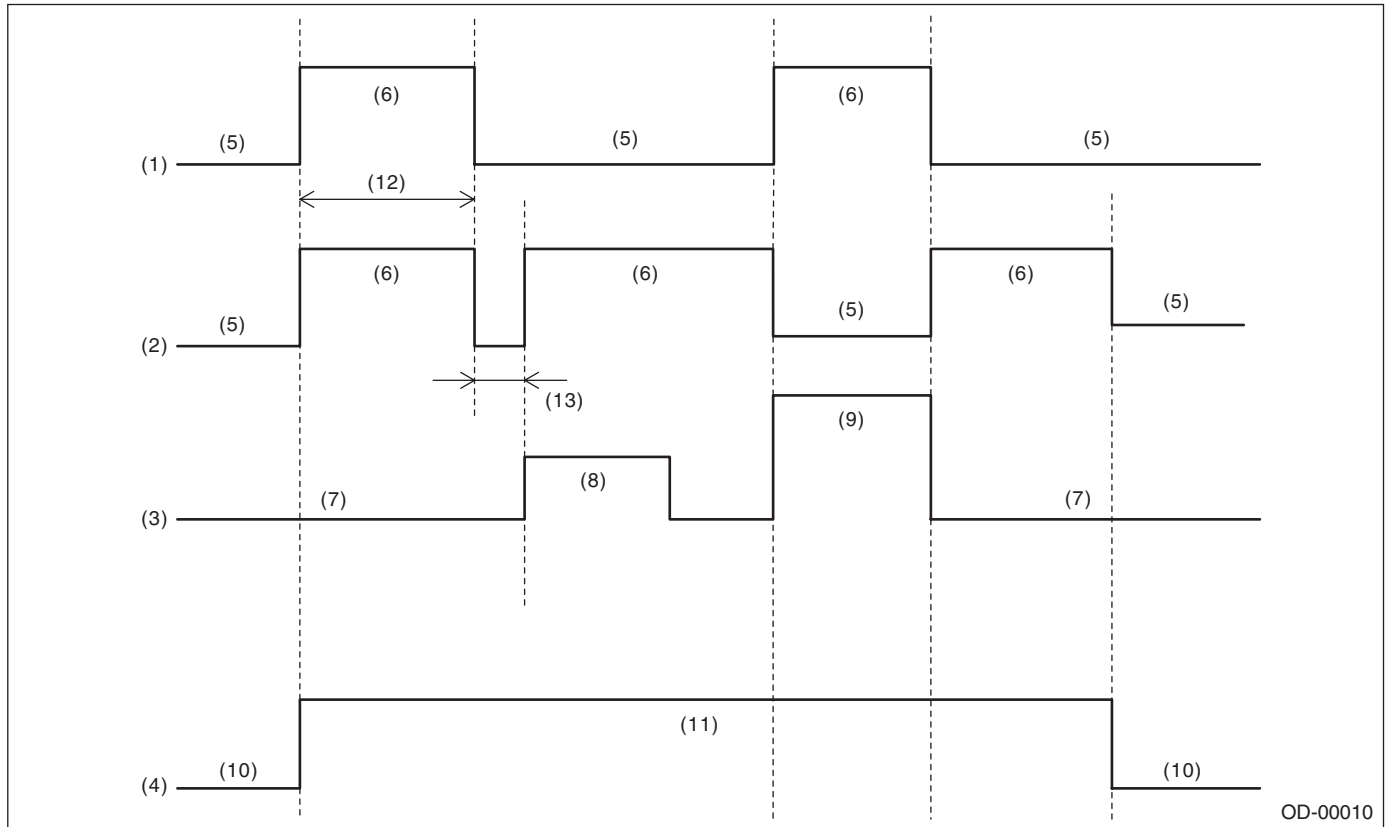

OD-00010

- | | | |
|--|---------------------|---------------------|
| (1) Passenger's airbag ON indicator light | (4) Ignition switch | (9) Adult |
| (2) Passenger's airbag OFF indicator light | (5) Light OFF | (10) OFF |
| (3) Occupant seating | (6) Light ON | (11) ON |
| | (7) Empty | (12) Approx. 6 sec. |
| | (8) Child | (13) Approx. 2 sec. |

List of Diagnostic Trouble Code (DTC)

OCCUPANT DETECTION SYSTEM (DIAGNOSTICS)

Brought to you by Eris Studios
NOT FOR RESALE

13. List of Diagnostic Trouble Code (DTC)

A: LIST

DTC	Display	Diagnosis content	Reference
2A	ODS Calibration Error	System calibration (Rezeroing) was not completed normally.	<Ref. to OD(diag)-23, DTC 2A ODS CALIBRATION ERROR, Diagnostic Procedure with Diagnostic Trouble Code (DTC).>
2B	ODS System Wrong Parts	<ul style="list-style-type: none"> • Wrong airbag control module was installed. • Wrong occupant detection system was installed. • Occupant detection system is faulty. 	<Ref. to OD(diag)-23, DTC 2B ODS SYSTEM WRONG PARTS, Diagnostic Procedure with Diagnostic Trouble Code (DTC).>
2C	Belt Tension Sensor Failure	<ul style="list-style-type: none"> • Passenger's seat belt tension sensor is faulty. • Airbag main harness circuit is open or shorted. • Occupant detection system is faulty. • Occupant detection harness is faulty. 	<Ref. to OD(diag)-24, DTC 2C BELT TENSION SENSOR FAILURE, Diagnostic Procedure with Diagnostic Trouble Code (DTC).>
27	ODS Communication Error	<ul style="list-style-type: none"> • Occupant detection control module and airbag control module communication is faulty. • Airbag rear harness circuit is open, shorted, shorted to ground or shorted to power supply. • Occupant detection harness is faulty. • Occupant detection system is faulty. • Airbag control module is faulty. 	<Ref. to OD(diag)-26, DTC 27 ODS COMMUNICATION ERROR, Diagnostic Procedure with Diagnostic Trouble Code (DTC).>
29	ODS Failure	<ul style="list-style-type: none"> • Occupant detection sensor is faulty. • Occupant detection control module is faulty. • Occupant detection harness is faulty. • Fuse No. 25 (in joint box) is blown. 	<Ref. to OD(diag)-26, DTC 29 ODS FAILURE, Diagnostic Procedure with Diagnostic Trouble Code (DTC).>
37	Buckle Switch RH Failure	<ul style="list-style-type: none"> • Passenger's buckle switch circuit is open, shorted or shorted to ground. • Occupant detection system is faulty. • Occupant detection harness is faulty. 	<Ref. to OD(diag)-27, DTC 37 BUCKLE SWITCH RH FAILURE, Diagnostic Procedure with Diagnostic Trouble Code (DTC).>

Diagnostic Procedure with Diagnostic Trouble Code (DTC)

OCCUPANT DETECTION SYSTEM (DIAGNOSTICS)

Brought to you by Eris Studios
NOT FOR SALE

14. Diagnostic Procedure with Diagnostic Trouble Code (DTC)

A: DTC 2A ODS CALIBRATION ERROR

DTC DETECTING CONDITION:

System calibration (Rezeroing) was not completed properly.

	Step	Check	Yes	No
1	PERFORM RE-ZEROING. Perform system calibration using the Subaru Select Monitor. <Ref. to OD(diag)-15, SYSTEM CALIBRATION (REZEROING), OPERATION, Subaru Select Monitor.>	Did the system calibration complete properly?	Finish the diagnosis.	Follow the system calibration procedures. <Ref. to OD(diag)-15, SYSTEM CALIBRATION (REZEROING), OPERATION, Subaru Select Monitor.>

B: DTC 2B ODS SYSTEM WRONG PARTS

DTC DETECTING CONDITION:

- Wrong airbag control module is installed.
- Wrong occupant detection system is installed.

	Step	Check	Yes	No
1	CHECK OCCUPANT DETECTION SYSTEM. 1) Turn the ignition switch to OFF, disconnect the battery ground cable, and wait for 20 seconds or more. 2) Replace the passenger's seat cushion pad frame assembly. <Ref. to SE-6, REMOVAL, Front Seat.> <Ref. to SE-8, PASSENGER'S SEAT, DISASSEMBLY, Front Seat.> 3) Connect the ground cable to the battery. 4) Connect Subaru Select Monitor to the vehicle and perform the system calibration. <Ref. to OD(diag)-15, SYSTEM CALIBRATION (REZEROING), OPERATION, Subaru Select Monitor.>	Did the system calibration complete properly?	Finish the diagnosis.	Go to step 2.
2	CHECK AIRBAG CONTROL SYSTEM. 1) Turn the ignition switch to OFF, disconnect the battery ground cable, and wait for 20 seconds or more. 2) Replace the airbag control module. <Ref. to AB-22, REMOVAL, Airbag Control Module.> 3) Connect the ground cable to the battery. 4) Connect Subaru Select Monitor to the vehicle and perform the system calibration. <Ref. to OD(diag)-15, SYSTEM CALIBRATION (REZEROING), OPERATION, Subaru Select Monitor.>	Did the system calibration complete properly?	Finish the diagnosis.	Check between the occupant detection control module and airbag control module.

Diagnostic Procedure with Diagnostic Trouble Code (DTC)

Brought to you by Eris Studios
NOT FOR RESALE

OCCUPANT DETECTION SYSTEM (DIAGNOSTICS)

C: DTC 2C BELT TENSION SENSOR FAILURE

DTC DETECTING CONDITION:

- Passenger's seat belt tension sensor is faulty.
- Airbag main harness circuit is open or shorted.
- Occupant detection control module is faulty.

WIRING DIAGRAM:

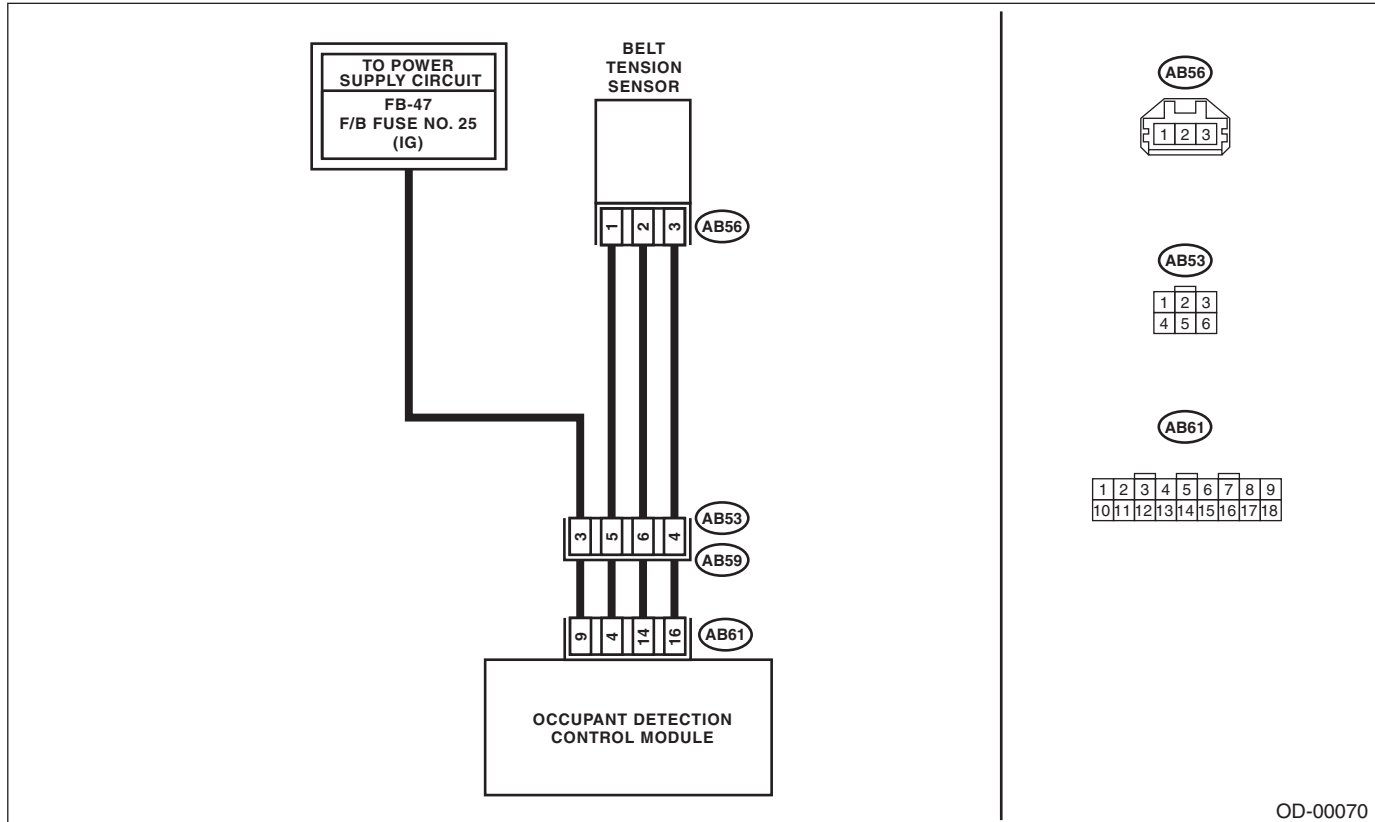

Diagnostic Procedure with Diagnostic Trouble Code (DTC)

OCCUPANT DETECTION SYSTEM (DIAGNOSTICS)

Brought to you by Eris Studios
 NOT FOR SALE

Step	Check	Yes	No
1 CHECK POOR CONTACT IN CONNECTORS. Check for poor contact of the connectors between the occupant detection control module and belt tension sensor.	Is there poor contact?	Reconnect the connector. If the fault is not fixed, replace the airbag harness.	Go to step 2.
2 CHECK THE BELT TENSION SENSOR. 1) Turn the ignition switch to OFF, disconnect the battery ground cable, and wait for 20 seconds or more. 2) Disconnect the belt tension sensor connector (AB56) from the airbag harness. 3) Connect the test harness AC to the connector (AB56). 4) Connect the battery ground terminal and turn the ignition switch to ON.	Does the airbag warning light illuminate for approximately 6 seconds and go off?	Replace the seat belt outer. <Ref. to SB-17, OUTER SEAT BELT ASSEMBLY, REMOVAL, Front Seat Belt.>	Go to step 3.
3 CHECK AIRBAG HARNESS. 1) Turn the ignition switch to OFF, disconnect the battery ground cable, and wait for 20 seconds or more. 2) Disconnect the test harness AC from the belt tension sensor connector (AB56). 3) Connect the test harness AD (1AD) to the connector (AB56). 4) Disconnect the airbag harness connector (AB53), and connect connector (1AB) of test harness AB. 5) Measure the resistance between test harness terminals. Connector & terminal (2AB) No. 5 — (2AD) No. 1: (2AB) No. 4 — (2AD) No. 3: (2AB) No. 6 — (2AD) No. 2:	Is the resistance less than 10 Ω?	Go to step 4.	Replace the airbag harness along with chassis harness.
4 CHECK AIRBAG HARNESS. Measure the resistance between test harness terminals, and between test harness terminal and chassis ground. Connector & terminal (2AB) No. 4 — (2AD) No. 1: (2AB) No. 4 — (2AD) No. 2: (2AB) No. 4 — chassis ground: (2AB) No. 5 — (2AD) No. 2: (2AB) No. 5 — chassis ground:	Is the resistance 1 MΩ or more?	Go to step 5.	Replace the airbag harness along with chassis harness.
5 CHECK AIRBAG HARNESS. 1) Connect the battery ground terminal and turn the ignition switch to ON. 2) Measure the voltage between test harness and chassis ground. Connector & terminal (2AD) No. 1 — chassis ground: (2AD) No. 3 — chassis ground:	Is the voltage 1 V or less?	Replace the airbag harness along with chassis harness.	Check the seat harness, and if any fault is found, replace the seat harness. If no fault is found in the seat harness, replace the seat cushion frame assembly. <Ref. to SE-8, PASSENGER'S SEAT, DISASSEMBLY, Front Seat.>

Diagnostic Procedure with Diagnostic Trouble Code (DTC)

OCCUPANT DETECTION SYSTEM (DIAGNOSTICS)

Brought to you by Eris Studios
NOT FOR RESALE

D: DTC 27 ODS COMMUNICATION ERROR

Perform the diagnosis following diagnostic procedures for the airbag system. <Ref. to AB(diag)-62, DTC 27 ODS COMMUNICATION ERROR, Diagnostic Chart with Trouble Code.>

E: DTC 29 ODS FAILURE

DTC DETECTING CONDITION:

- Occupant detection sensor is faulty.
- Occupant detection control module is faulty.
- Occupant detection harness is faulty.
- Rear airbag harness is faulty.
- Fuse No. 25 (in joint box) is blown.

Step	Check	Yes	No
1 CHECK POOR CONTACT IN CONNECTORS. Check for poor contact of the connectors between the occupant detection control module and airbag control module.	Is there poor contact?	Reconnect the connector. If the fault is not fixed, replace the airbag harness.	Go to step 2.
2 CHECK DIAGNOSTIC TROUBLE CODE (DTC). Read diagnostic trouble code (DTC) for the airbag system.	Is "2C Belt Tension Sensor failure or 37 Buckle Switch failure" displayed in the diagnostics code?	Perform the diagnosis according to each DTC.	Check the seat harness, and if any fault is found, replace the seat harness. If the fault is not fixed, replace the occupant detection system. <Ref. to SE-8, PASSENGER'S SEAT, DISASSEMBLY, Front Seat.>

Diagnostic Procedure with Diagnostic Trouble Code (DTC)

OCCUPANT DETECTION SYSTEM (DIAGNOSTICS)

Brought to you by Eris Studios
NOT FOR SALE

F: DTC 37 BUCKLE SWITCH RH FAILURE

DTC DETECTING CONDITION:

- Passenger's buckle switch circuit is open, shorted or shorted to ground.
- Seat harness circuit is open, shorted or shorted to ground.
- Occupant detection control module is faulty.

WIRING DIAGRAM:

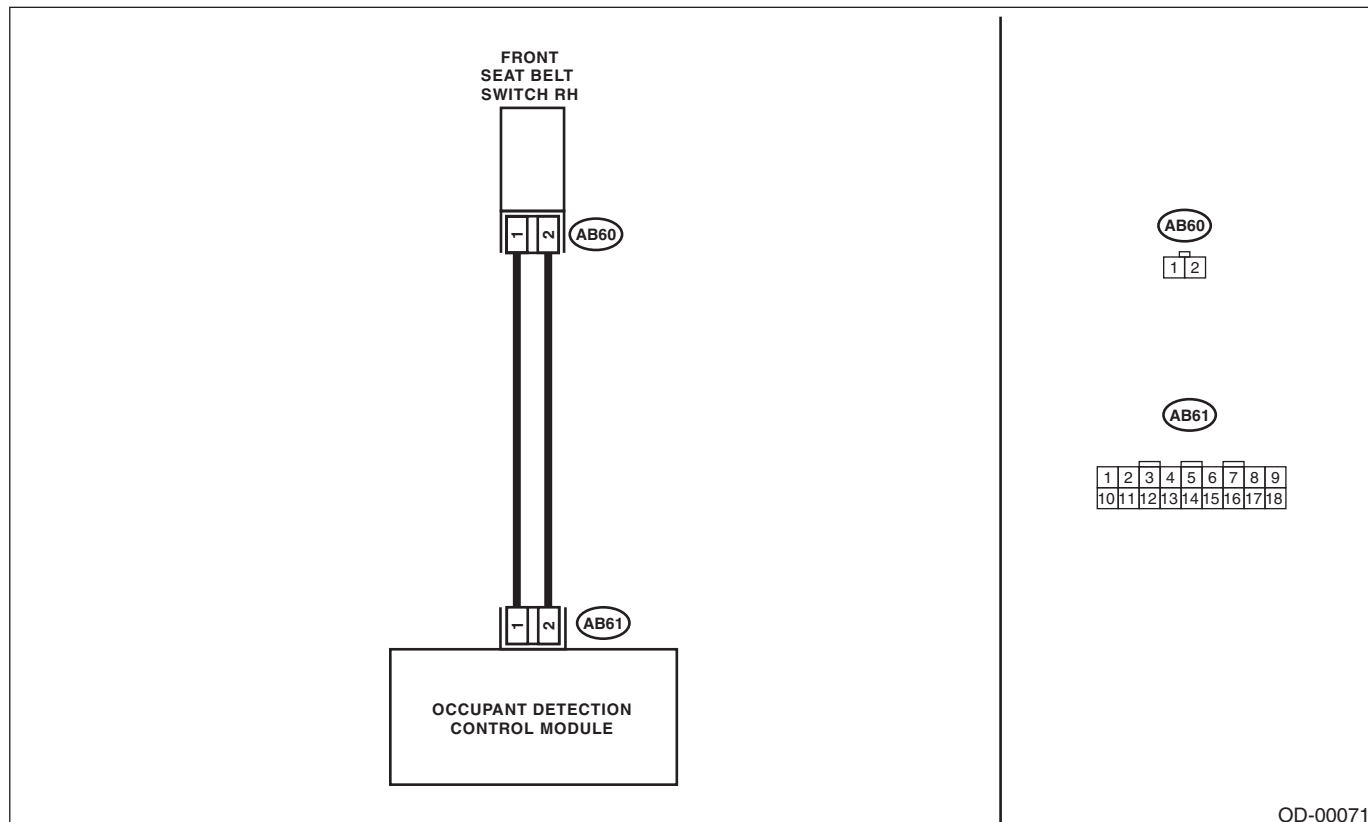

OD-00071

Step	Check	Yes	No
1 CHECK POOR CONTACT IN CONNECTORS. Check for poor contact of the connectors between the occupant detection control module and buckle switch.	Is there poor contact?	Reconnect the connector. If the fault is not fixed, replace the airbag harness.	Go to step 2.
2 CHECK THE BUCKLE SWITCH. 1) Turn the ignition switch to OFF, disconnect the battery ground terminal, and wait for 20 seconds. 2) Disconnect the buckle switch connector (AB60). 3) Connect the test harness AE1 and test harness connector Y to the buckle switch connector (AB60). 4) Connect the battery ground terminal and turn the ignition switch to ON.	Does the airbag warning light illuminate for 6 seconds and go off?	Replace the buckle switch. <Ref. to SB-17, INNER SEAT BELT ASSEMBLY, REMOVAL, Front Seat Belt.>	Check the seat harness, and if any fault is found, replace the seat harness. If the fault is not fixed, replace the occupant detection system.

Diagnostic Procedure with Diagnostic Trouble Code (DTC)

OCCUPANT DETECTION SYSTEM (DIAGNOSTICS)

Brought to you by Eris Studios
NOT FOR RESALE