

Brought to you by Eris Studios  
NOT FOR RESALE

# SEAT BELT SYSTEM

# General Description

## SEAT BELT SYSTEM

Brought to you by Eris Studios  
NOT FOR RESALE

### 1. General Description

#### A: COMPONENT

#### 1. FRONT SEAT BELT

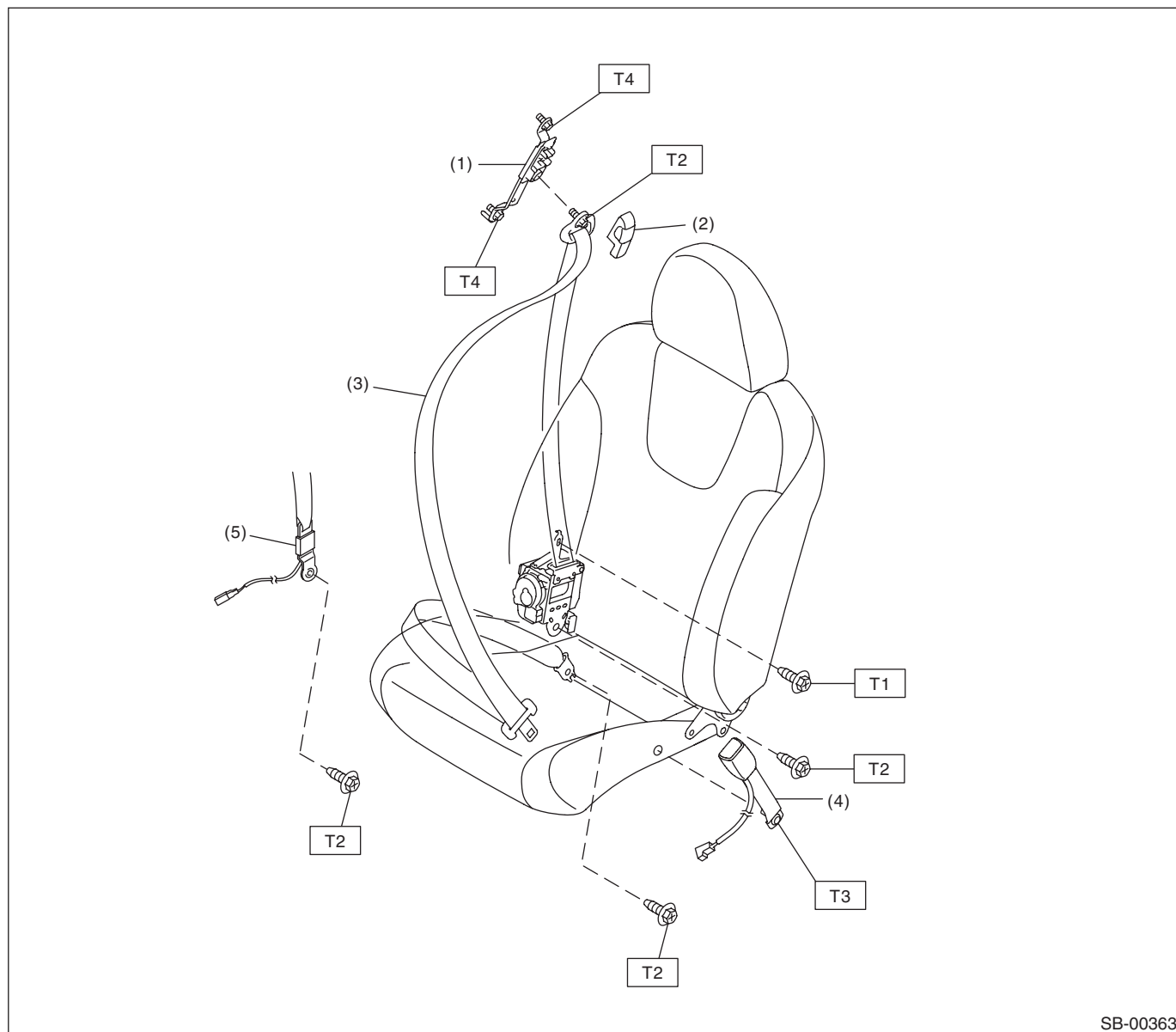

SB-00363

- |                            |  |
|----------------------------|--|
| (1) Adjustable anchor ASSY | (4) Inner seat belt ASSY                             |
| (2) Anchor cover           | (5) Belt tensioner sensor<br>(Passenger's side only) |
| (3) Outer belt ASSY        |  |

**Tightening torque: N·m (kgf·m, ft·lb)**

**T1: 7.5 (0.76, 5.5)**

**T2: 30 (3.1, 22)**

**T3: 38 (3.9, 28)**

**T4: 53 (5.4, 39)**

Brought to you by  
 NOT FOR SALE  
 Chris Studios

### 2. REAR SEAT BELT

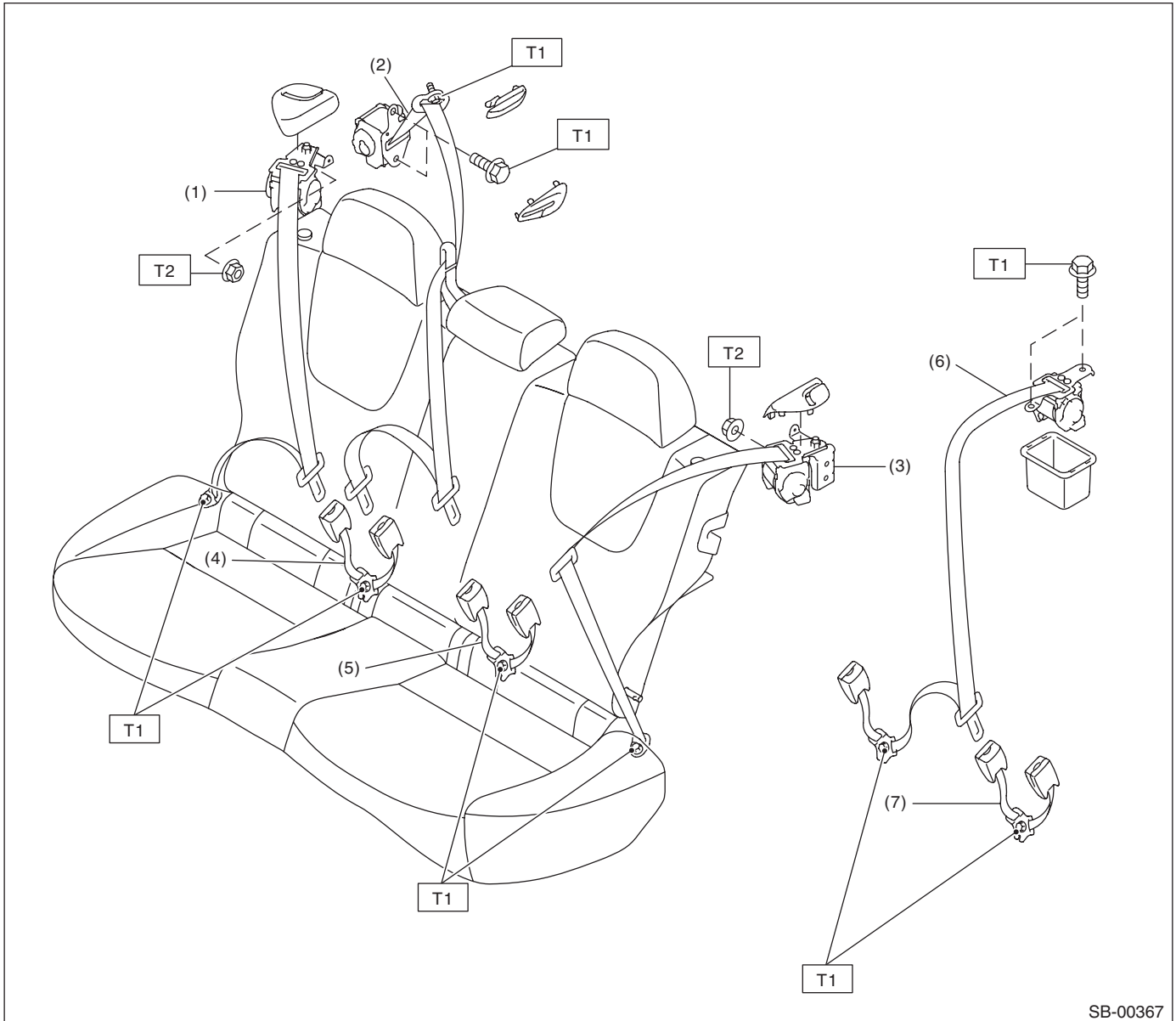

SB-00367

- |   |   |
|---|---|
| (1) Outer seat belt ASSY RH                         | (5) Center seat belt ASSY LH<br>(3-point type)      |
| (2) Shoulder seat belt center ASSY<br>(Wagon model) | (6) Shoulder seat belt center ASSY<br>(Sedan model) |
| (3) Outer seat belt ASSY LH                         | (7) Center seat belt ASSY LH<br>(Sedan model)       |
| (4) Center seat belt ASSY RH<br>(Wagon model)       |   |

**Tightening torque: N·m (kgf·m, ft·lb)**

**T1: 30 (3.1, 22)**

**T2: 53 (5.4, 39)**

### **B: CAUTION**

- Before starting the work, turn the ignition switch to OFF, disconnect the battery ground cable and wait for 20 seconds or more.
- The pretensioner system has a backup power source. Be aware that the pretensioner might deploy if you do not wait for 20 seconds or more before starting work.
- Do not drop or apply any impact to the pretensioner.
- If oil, grease or water gets on the pretensioner, wipe it off immediately with a dry cloth.
- Do not expose the pretensioner to high temperature or flame.
- Do not allow current to flow through or voltage to reach the pretensioner. Do not use a circuit tester to check resistance of the pretensioner.
- Do not disassemble or attempt to repair the pretensioner. If it is dented, cracked or deformed, replace it with a new part.
- Do not use the airbag or pretensioner parts from other vehicles. Always perform any replacement with new parts.
- When handling a seat belt with deployed pretensioner, wear gloves and goggles. Wash your hands afterwards.
- Do not reuse a seat belt with deployed pretensioner.

## C: PREPARATION TOOL

### 1. SPECIAL TOOL

- SUBARU SELECT MONITOR

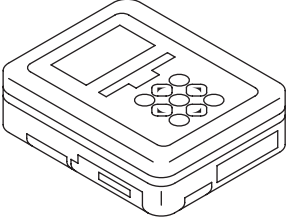
| ILLUSTRATION  | TOOL NUMBER | DESCRIPTION                   | REMARKS  |
|---|-------------|-------------------------------|--|
| <br>ST1B021XU0 | 1B021XU0    | SUBARU SELECT MONITOR III KIT | Used for settings of each function and trouble-shooting for electrical system. |

- TEST HARNESS AB

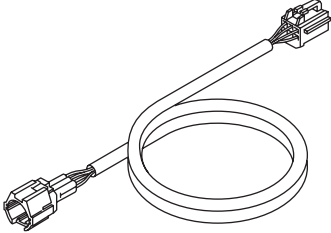
| ILLUSTRATION   | TOOL NUMBER | DESCRIPTION     | REMARKS  |
|--|-------------|-----------------|--|
| <br>ST98299XA000 | 98299XA000  | TEST HARNESS AB | Used when measuring voltage and resistance of occupant detection system. |

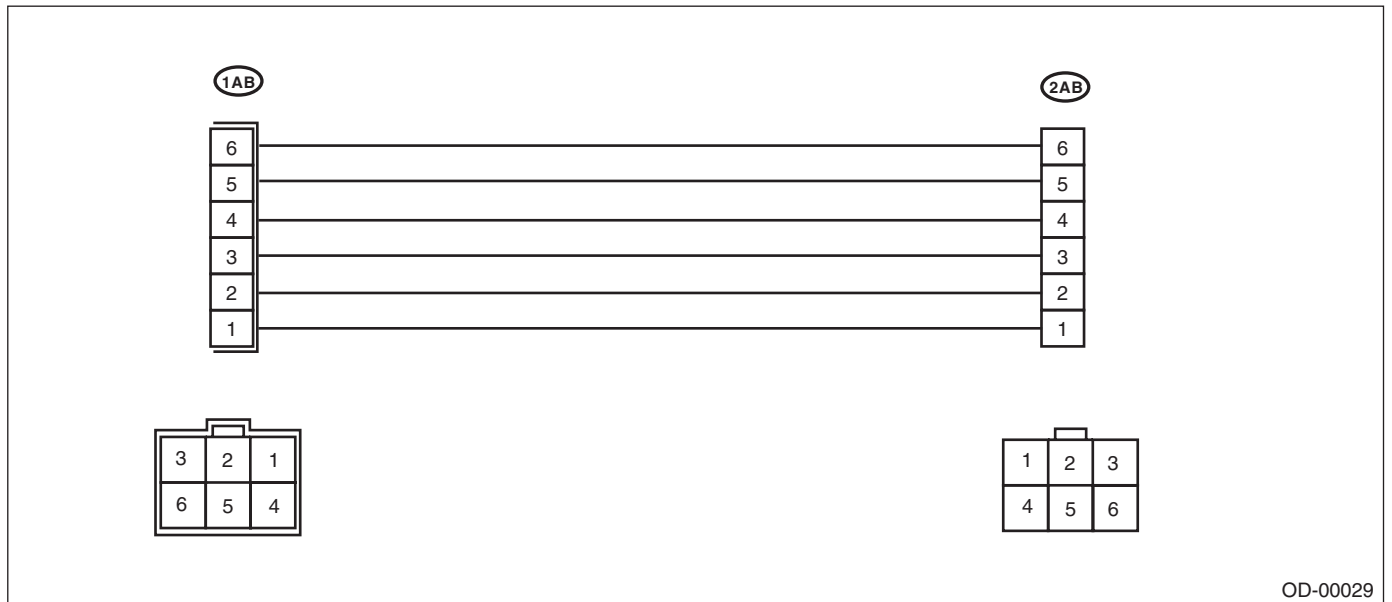

OD-00029

# General Description

Brought to you by Eris Studios  
NOT FOR RESALE

## SEAT BELT SYSTEM

### • TEST HARNESS AE

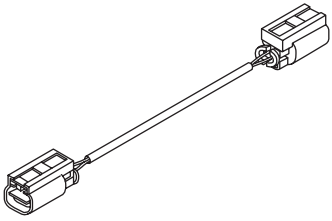
| ILLUSTRATION  | TOOL NUMBER | DESCRIPTION     | REMARKS  |
|---|-------------|-----------------|--|
| <br>ST98299XA030 | 98299XA030  | TEST HARNESS AE | <ul style="list-style-type: none"><li>• Used for diagnosing seat belt tension sensor.</li><li>• Used together with the test harness Y.</li></ul> |

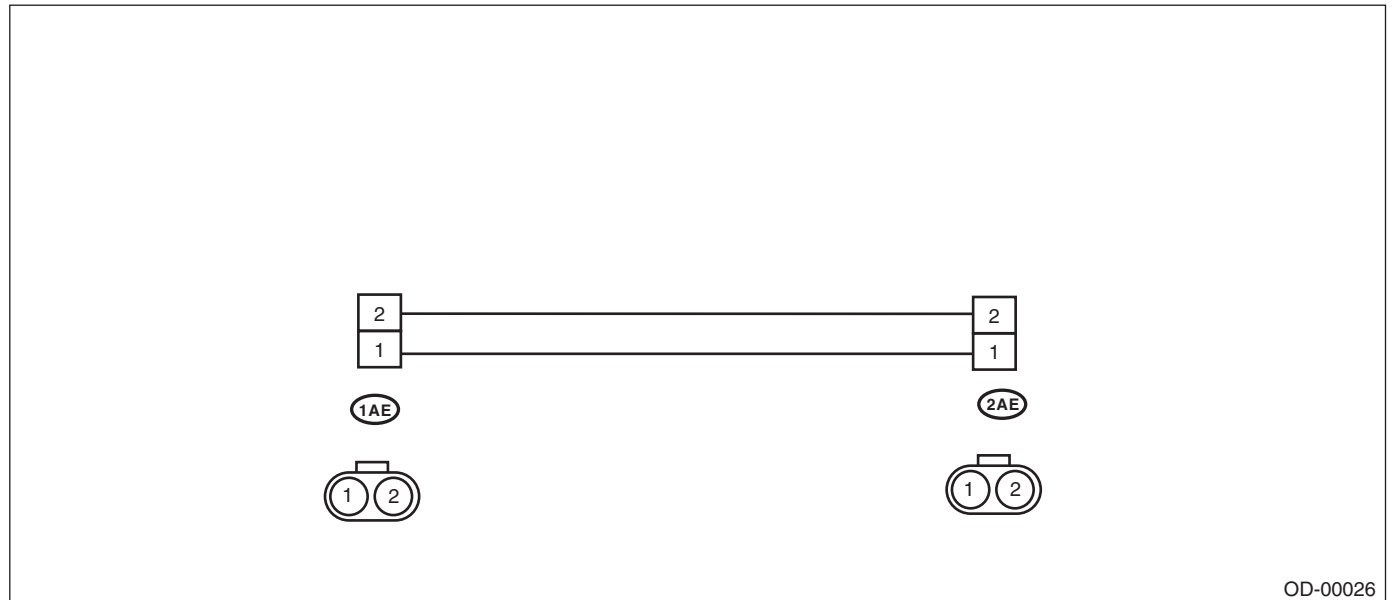

# General Description

Brought to you by *Meris Studios*  
 NOT FOR SALE

## • TEST HARNESS AG

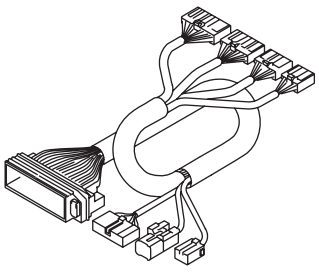
| ILLUSTRATION  | TOOL NUMBER | DESCRIPTION     | REMARKS  |
|---|-------------|-----------------|--|
|  <p>ST98299AG070</p> | 98299AG070  | TEST HARNESS AG | Used when measuring voltage and resistance of airbag control module. |

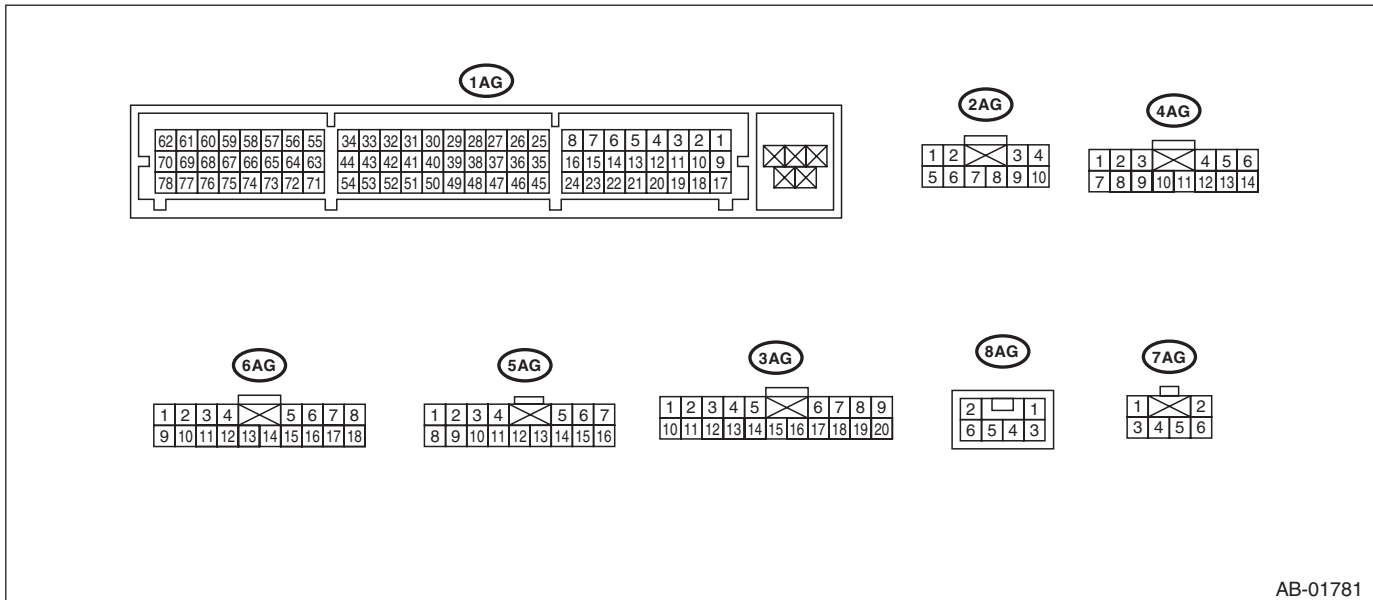

# General Description

## SEAT BELT SYSTEM

Brought to you by Eris Studios  
NOT FOR RESALE

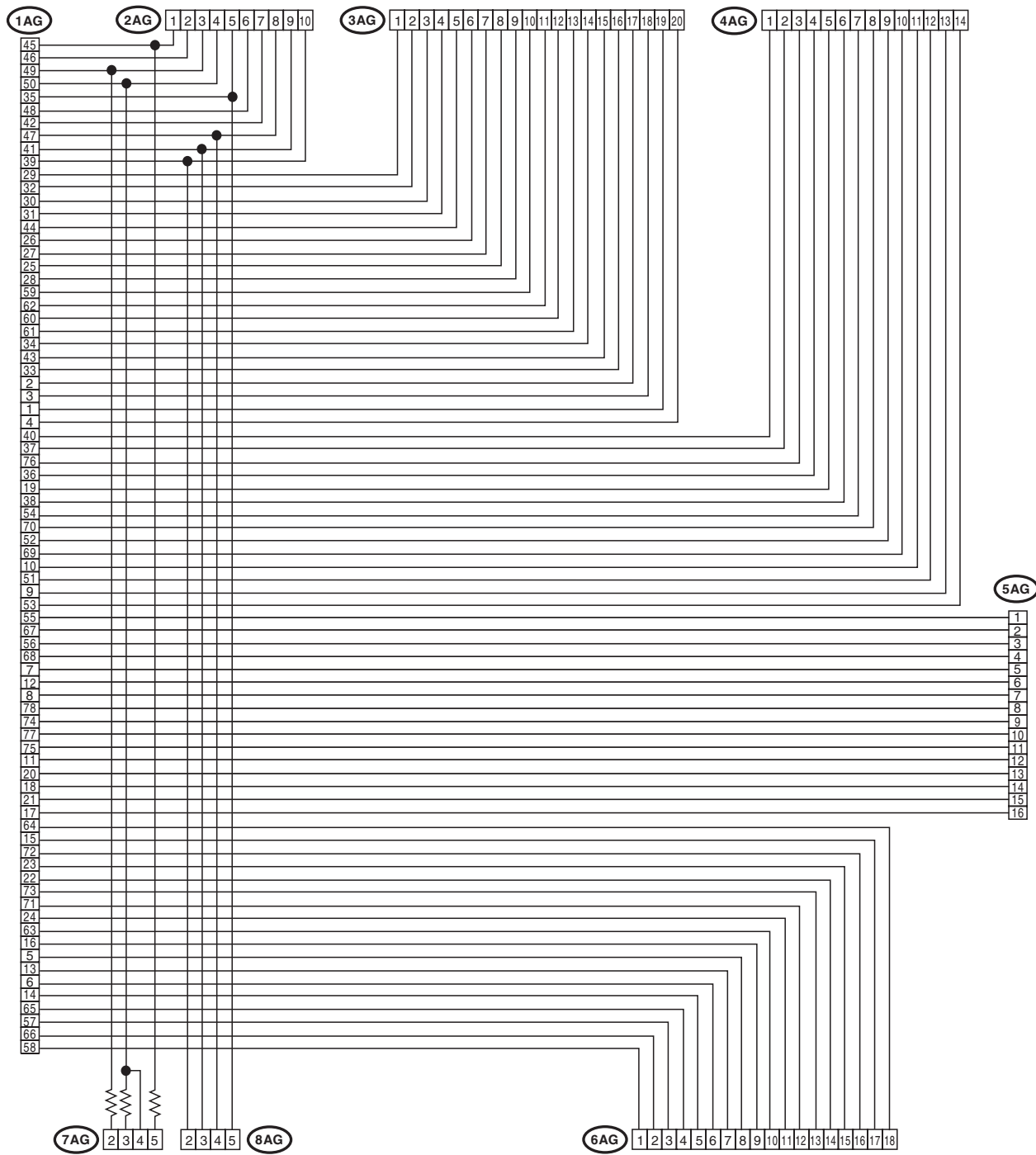

AB-01902



# General Description

Brought to you by *Chris Studios*  
 NOT FOR SALE

## • TEST HARNESS Y

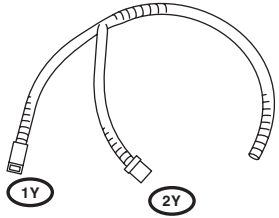
| ILLUSTRATION  | TOOL NUMBER | DESCRIPTION    | REMARKS                                      |
|---|-------------|----------------|--|
|  <p data-bbox="321 558 467 579">ST98299AG040</p> | 98299AG040  | TEST HARNESS Y | Used for diagnosing seat belt buckle switch. |

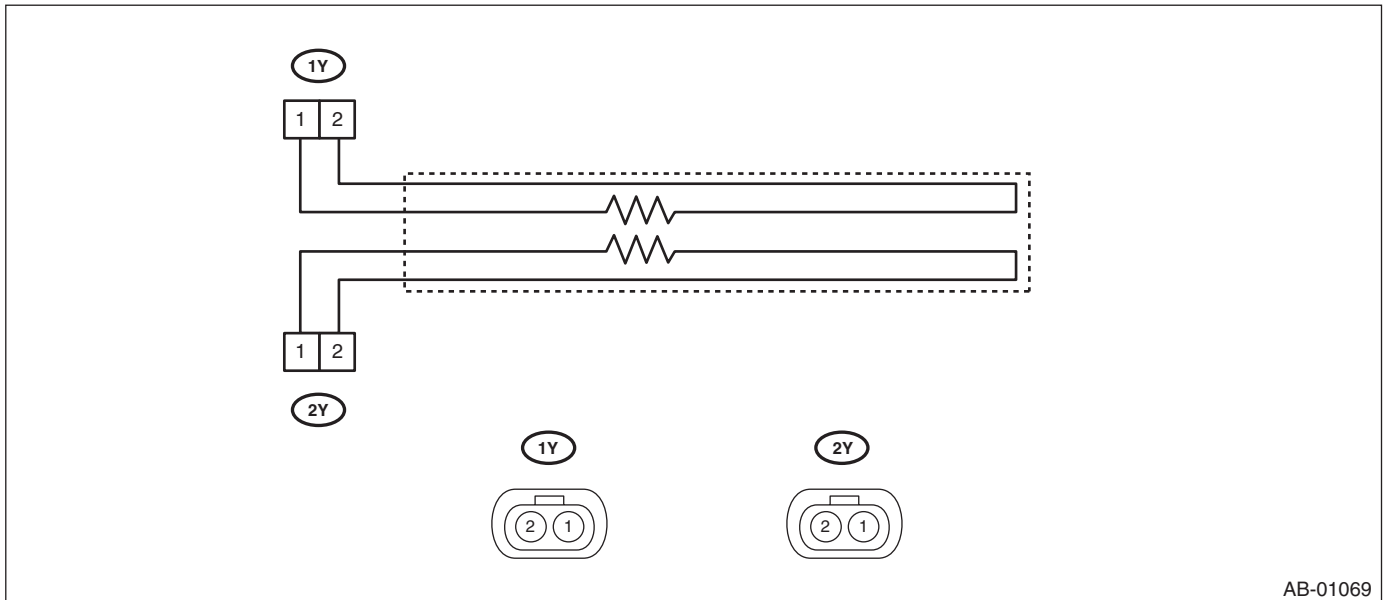

# General Description

Brought to you by Eris Studios  
NOT FOR RESALE

## SEAT BELT SYSTEM

### • AIRBAG RESISTOR

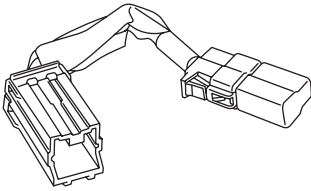
| ILLUSTRATION  | TOOL NUMBER | DESCRIPTION     | REMARKS  |
|---|-------------|-----------------|--|
|  <p>ST98299PA040</p> | 98299PA040  | AIRBAG RESISTOR | Used in replacement of airbag module for which resistance value is same as airbag module.<br>Two ST are required for diagnosis of two-stage inflator type airbag module. |

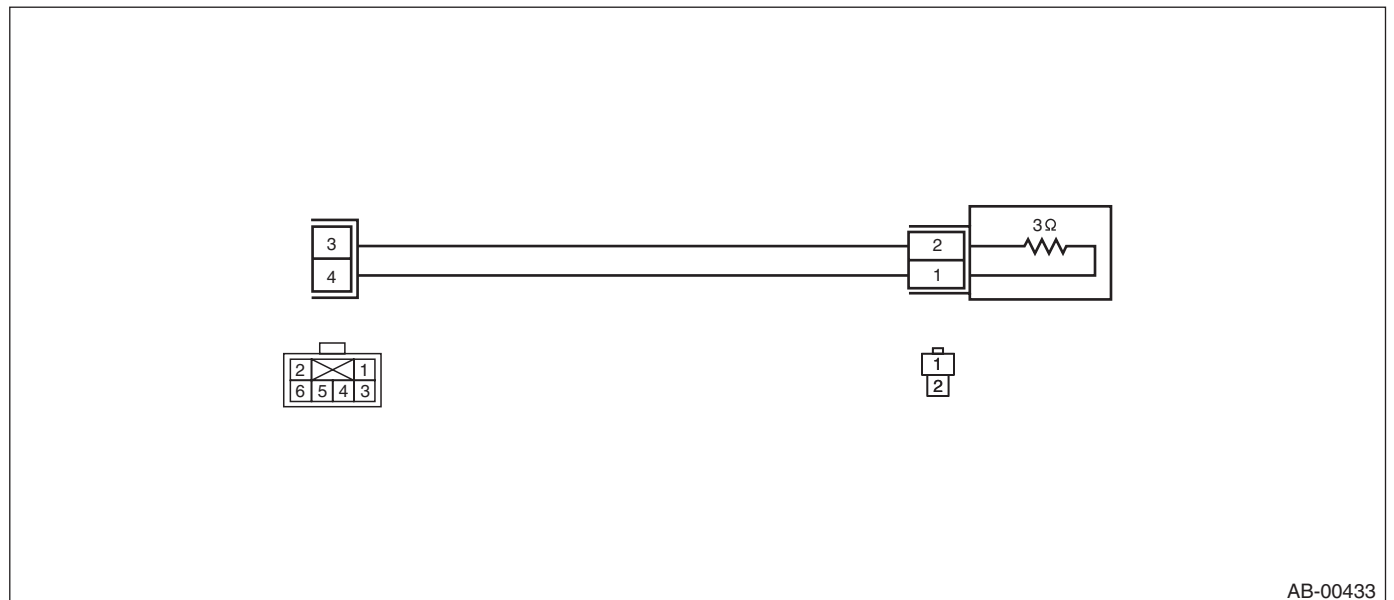

## 2. GENERAL TOOL

| TOOL NAME      | REMARKS  |
|----------------|--|
| TORX® T50      | Used for removing and installing the inner seat belt assembly. |
| Circuit tester | Used for measuring resistance and voltage.                     |

---

## 2. Pretensioner Connector

### A: PROCEDURE

Refer to “Airbag Connector” of Airbag section for the connectors of the seat belt pretensioners and buckle switch RH. <Ref. to AB-9, PROCEDURE, Airbag Connector.>

## 3. Inspection Locations After a Collision

### A: INSPECTION

Refer to “Inspection Locations After a Collision” of Airbag section. <Ref. to AB-13, Inspection Locations After a Collision.>

Brought to you by  
NOT FOR SALE  
Chris Studios

## 4. Seat Belt Warning System

### A: WIRING DIAGRAM

<Ref. to WI-153, WIRING DIAGRAM, Seat Belt Warning System.>

### B: INSPECTION

#### CAUTION:

- Before diagnosing the airbag system, be sure to turn the ignition switch to OFF, disconnect the ground cable from the battery, and wait 20 seconds or more before starting to work.
- When replacing the airbag module, seat belt pretensioner, roll connector, control module and sensor, reconnect each part and check that the warning light operates properly.
- When inspecting the airbag main harness, disconnect the airbag module connectors of the driver's and passenger's seats for safety.
- When inspecting the airbag rear harness, disconnect the side airbag module connector, curtain airbag module connector and seat belt pretensioner connector for safety reasons.

#### TROUBLE SYMPTOM:

- Driver's side seat belt warning light does not turn on or off.
- Warning buzzer does not beep.

| Step | Check  | Yes  | No            |   |
|------|--|--|---------------|---|
| 1    | <b>CHECK BODY INTEGRATED UNIT.</b><br>1) Sit on the driver's seat and passenger's seat.<br>2) Prepare the Subaru Select Monitor kit.<br>3) Turn the ignition switch to ON (engine OFF), and run the "PC application for Subaru Select Monitor".<br>4) Read the data of ignition power supply voltage from Subaru Select Monitor. <Ref. to LAN(diag)-14, OPERATION, Subaru Select Monitor.> | Is the voltage 10 V or more?   | Go to step 2. | Check the ignition switch circuit.                |
| 2    | <b>CHECK BODY INTEGRATED UNIT.</b><br>Read the data of the belt warning switch. <Ref. to LAN(diag)-14, OPERATION, Subaru Select Monitor.>  | Is the belt warning display ON?  | Go to step 3. | Turn the belt warning ON with unit customization. |
| 3    | <b>CHECK BODY INTEGRATED UNIT.</b><br>1) Read the data of the driver's seat belt switch. <Ref. to LAN(diag)-14, OPERATION, Subaru Select Monitor.><br>2) Connect and disconnect the seat belt buckle.  | Does the seat belt SW display turn ON ←→ OFF according to the operation? | Go to step 8. | Go to step 4.                                     |
| 4    | <b>CHECK HARNESS.</b><br>1) Disconnect the negative terminal from the battery, and wait for more than 20 seconds.<br>2) Measure the resistance between the body integrated unit and the seat belt buckle switch LH.<br><b>Connector &amp; terminal</b><br><b>(B281) No. 16 — (R107) No. 3:</b>   | Is the harness normal?   | Go to step 5. | Repair the harness.                               |
| 5    | <b>CHECK HARNESS.</b><br>Check for short circuit to battery, open circuit and short circuit to ground between the seat belt buckle switch LH and chassis ground.<br><b>Connector &amp; terminal</b><br><b>(R8) No. 1 — Chassis ground:</b>   | Is the harness normal?   | Go to step 6. | Repair the harness.                               |

# Seat Belt Warning System

## SEAT BELT SYSTEM

Brought to you by Eris Studios  
NOT FOR RESALE

| Step  | Check   | Yes  | No  |
|---|---|--|---|
| <b>6 CHECK SEAT BELT BUCKLE SWITCH LH.</b><br>1) Insert the tongue plate to the driver's seat belt buckle.<br>2) Check for short circuit to battery and open circuit between the seat belt switch LH connectors (R8).<br><i>Connector &amp; terminal</i><br><i>(R8) No. 1 — (R8) No. 3:</i>   | Is the resistance 1 M $\Omega$ or more?   | Go to step 7.  | Replace the inner belt assembly LH.<br><Ref. to SB-17, REMOVAL, Front Seat Belt.> |
| <b>7 CHECK SEAT BELT BUCKLE SWITCH LH.</b><br>1) Disconnect the driver's seat belt buckle and the tongue plate.<br>2) Measure the resistance between the terminals of the seat belt switch LH connectors (R8).<br><i>Connector &amp; terminal</i><br><i>(R8) No. 1 — (R8) No. 3:</i>  | Is the resistance less than 10 $\Omega$ ?   | Replace the body integrated unit.<br><Ref. to SL-53, REMOVAL, Body Integrated Unit.> | Replace the inner belt assembly LH.<br><Ref. to SB-17, REMOVAL, Front Seat Belt.> |
| <b>8 CHECK BODY INTEGRATED UNIT.</b><br>1) Read the data of the passenger's seat belt switch. <Ref. to LAN(diag)-14, OPERATION, Subaru Select Monitor.><br>2) Connect and disconnect the seat belt buckle.  | Does the seat belt SW display turn ON $\longleftrightarrow$ OFF according to the operation? | Go to step 12.   | Go to step 9.   |
| <b>9 CHECK AIRBAG SYSTEM AND OCCUPANT DETECTION SYSTEM.</b><br>Perform the check in accordance with the diagnostic procedure DTC 27 of the airbag system. <Ref. to AB(diag)-62, DTC 27 ODS COMMUNICATION ERROR, Diagnostic Chart with Trouble Code.>  | Is there any problem on the inspection result?  | Go to step 10.   | Repair or replace the harness.  |
| <b>10 CHECK BUCKLE SWITCH RH.</b><br>Perform the check in accordance with the diagnostic procedure DTC 37 of the occupant detection system. <Ref. to OD(diag)-27, DTC 37 BUCKLE SWITCH RH FAILURE, Diagnostic Procedure with Diagnostic Trouble Code (DTC).>  | Is there any problem on the inspection result?  | Go to step 11.   | Repair or replace the harness.  |
| <b>11 CHECK AIRBAG CONTROL MODULE AND BODY INTEGRATED UNIT.</b><br>Check the airbag control module, occupant detection sensor and seat belt buckle switch RH. Perform the check in accordance with the diagnostic procedure DTC 39 of the airbag system. <Ref. to AB(diag)-64, DTC 39 SEAT BELT WARNING FAILURE, Diagnostic Chart with Trouble Code.> | Is there any problem on the inspection result?  | Replace the body integrated unit.<br><Ref. to SL-53, REMOVAL, Body Integrated Unit.> | Repair or replace the harness.  |
| <b>12 CHECK SEAT BELT WARNING LIGHT.</b><br>Turn the ignition switch to OFF, disconnect the seat belt of the driver's and passenger's seat.   | Does the driver's seat belt warning light blink?  | Go to step 15.   | Go to step 13.  |
| <b>13 CHECK METER.</b><br>1) Turn the ignition switch to OFF.<br>2) Turn the ignition switch to ON again.   | Does seat belt warning light illuminate with combination meter initialization?              | Go to step 14.   | Check the combination meter.  |
| <b>14 CHECK DTC.</b><br>Read the DTC using the Subaru Select Monitor.   | Are any body CAN related DTC detected?  | Check the CAN according to DTC.  | There may be an abnormal internal control. Replace the body integrated unit.      |
| <b>15 CHECK SEAT BELT WARNING LIGHT.</b><br>Check the passenger's seat belt warning light.  | Does the passenger's seat belt warning light blink?   | Go to step 19.   | Go to step 16.  |

# Seat Belt Warning System

## SEAT BELT SYSTEM

Brought to you by Chris Studios  
NOT FOR SALE

| Step  | Check   | Yes   | No  |
|---|---|---|---|
| <b>16 CHECK HARNESS.</b><br>Measure the resistance between clock unit and body integrated unit.<br><b>Connector &amp; terminal</b><br><b>(i84) No. 25 — (i59) No. 2:</b>  | Is the resistance less than 10 Ω?                                 | Go to step 17.  | Repair the harness.   |
| <b>17 CHECK HARNESS.</b><br>1) Connect the ground cable to the battery.<br>2) Measure the voltage between clock unit connector and chassis ground.<br><b>Connector &amp; terminal</b><br><b>(i59) No. 8 (+) — Chassis ground (-):</b> | Is the voltage 10 V or more?                                      | Go to step 18.  | Repair the harness.   |
| <b>18 CHECK SEAT BELT WARNING LIGHT.</b><br>1) Connect the ground cable to the battery.<br>2) Disconnect the connector from clock unit.<br>3) Short No. 8 of the clock unit connector (i59).  | Does seat belt warning light illuminate?                          | Replace the body integrated unit.<br><Ref. to SL-53, REMOVAL, Body Integrated Unit.>  | Check the clock unit.   |
| <b>19 CHECK BODY INTEGRATED UNIT.</b><br>Check if the warning buzzer sounds.  | Does the warning buzzer sound?                                    | Go to step 21.  | Go to step 20.  |
| <b>20 CHECK COMBINATION METER.</b><br>Perform self-diagnosis of the combination meter. <Ref. to IDI-4, SELF-DIAGNOSIS, INSPECTION, Combination Meter System.>   | Did the buzzer sound?   | Go to step 14.  | Replace the combination meter.<br><Ref. to IDI-14, REMOVAL, Combination Meter.> |
| <b>21 CHECK SEAT BELT WARNING LIGHT.</b><br>1) Connect the passenger's seat belt.<br>2) Wait until the warning buzzer stops sounding.<br>3) Start the engine, and set the vehicle speed to 15 km/h (9 MPH) or faster.                 | Does the driver's seat belt warning light blink and buzzer sound? | Go to step 25.  | Go to step 22.  |
| <b>22 CHECK BODY INTEGRATED UNIT.</b><br>Read the DTC of body integrated unit using Subaru Select Monitor.  | Is DTC U1223 detected?  | <ul style="list-style-type: none"> <li>• Check the LAN system. &lt;Ref. to LAN(diag)-74, DTC U1223 CANS VDC/ABS NO-RECEIVE DATA, Diagnostic Procedure with Diagnostic Trouble Code (DTC).&gt;</li> <li>• Check VDC or ABS.</li> <li>• VDC &lt;Ref. to VDC(diag)-2, Basic Diagnostic Procedure.&gt;</li> <li>• ABS &lt;Ref. to ABS(diag)-2, Basic Diagnostic Procedure.&gt;</li> </ul> | Go to step 23.  |

# Seat Belt Warning System

## SEAT BELT SYSTEM

Brought to you by Eris Studios  
NOT FOR RESALE

| Step   | Check   | Yes   | No  |
|--|---|---|---|
| <b>23</b><br><b>CHECK BODY INTEGRATED UNIT.</b><br>Read the data of the "front wheel speed" from the body integrated unit. <Ref. to LAN(diag)-14, OPERATION, Subaru Select Monitor.> | Is the data displayed as 999.9 km/h?  | <ul style="list-style-type: none"> <li>• Check the LAN system. &lt;Ref. to LAN(diag)-74, DTC U1223 CAN-HS VDC/ABS NO-RECEIVE DATA, Diagnostic Procedure with Diagnostic Trouble Code (DTC).&gt;</li> <li>• Check VDC or ABS.</li> <li>• VDC &lt;Ref. to VDC(diag)-2, Basic Diagnostic Procedure.&gt;</li> <li>• ABS &lt;Ref. to ABS(diag)-2, Basic Diagnostic Procedure.&gt;</li> </ul> | Go to step 24.  |
| <b>24</b><br><b>CHECK BODY INTEGRATED UNIT.</b><br>Read the data of the "front wheel speed" from the body integrated unit. <Ref. to LAN(diag)-14, OPERATION, Subaru Select Monitor.> | Does the data indicate the normal vehicle speed?                                  | Replace the body integrated unit. <Ref. to SL-53, REMOVAL, Body Integrated Unit.>   | <ul style="list-style-type: none"> <li>• Check the LAN system. &lt;Ref. to LAN(diag)-74, DTC U1223 CAN-HS VDC/ABS NO-RECEIVE DATA, Diagnostic Procedure with Diagnostic Trouble Code (DTC).&gt;</li> <li>• Check VDC or ABS.</li> <li>• VDC &lt;Ref. to VDC(diag)-2, Basic Diagnostic Procedure.&gt;</li> <li>• ABS &lt;Ref. to ABS(diag)-2, Basic Diagnostic Procedure.&gt;</li> </ul> |
| <b>25</b><br><b>CHECK WARNING LIGHT AND BUZZER.</b><br>Connect the driver's seat belt.   | Does the driver's seat belt warning light go off and the buzzer stop sounding?    | Go to step 26.  | Replace the combination meter. <Ref. to IDI-14, REMOVAL, Combination Meter.>  |
| <b>26</b><br><b>CHECK WARNING LIGHT AND BUZZER.</b><br>Disconnect the passenger's seat belt.   | Does the passenger's seat belt warning light blink and buzzer sound?              | Go to step 27.  | Go to step 22.  |
| <b>27</b><br><b>CHECK WARNING LIGHT AND BUZZER.</b><br>Connect the passenger's seat belt.  | Does the passenger's seat belt warning light go off and the buzzer stop sounding? | System is normal. Temporary poor contact.   | Replace the body integrated unit. <Ref. to SL-53, REMOVAL, Body Integrated Unit.>   |



Brought to you by Chris Studios  
NOT FOR RESALE

## 5. Front Seat Belt

### A: REMOVAL

#### 1. OUTER SEAT BELT ASSEMBLY

- 1) Before working, turn the ignition switch to OFF, disconnect the battery ground cable, and wait for 20 seconds or more.
- 2) Fold the backrest all the way forward, and then move the front seat all the way forward.
- 3) Remove the center pillar lower trim. <Ref. to EI-53, REMOVAL, Lower Inner Trim.>
- 4) Remove the anchor cover (A).
- 5) Loosen the shoulder anchor bolt (B), and then detach the shoulder anchor from center pillar.

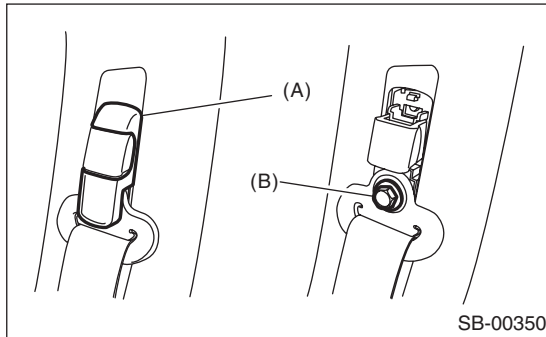

- 6) Turn over the floor mat to disconnect the connector (A) of belt tension sensor.
- 7) Loosen the three bolts to remove the front outer belt.

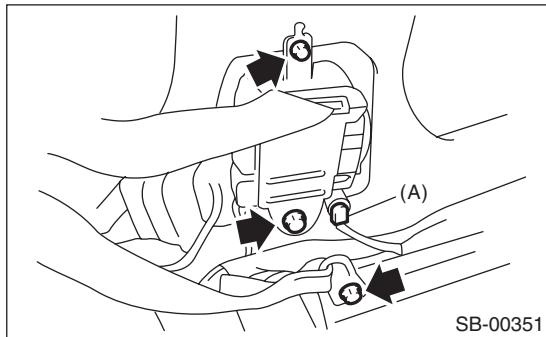

- 8) Remove the center pillar upper trim. <Ref. to EI-54, REMOVAL, Upper Inner Trim.>

- 9) Remove the two bolts to remove the adjustable anchor assembly.

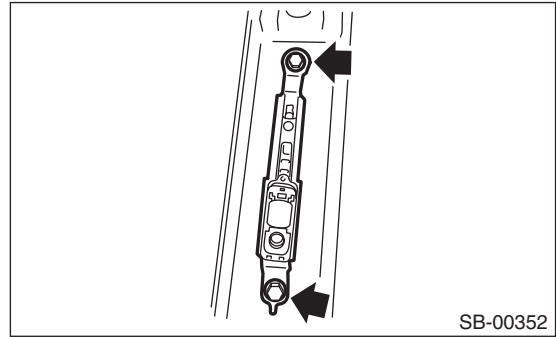

#### CAUTION:

- Do not drop or subject the pretensioner to any impact.
- Since the pretensioner and bracket are integrated as a unit, do not disassemble them.

#### 2. INNER SEAT BELT ASSEMBLY

- 1) Turn the ignition switch to OFF, disconnect the battery ground cable, and wait for 20 seconds or more.
- 2) Remove the console box. <Ref. to EI-47, REMOVAL, Console Box.>
- 3) Disconnect the seat belt warning light connector under the seat.
- 4) Remove the harness clips from slide rail.
- 5) Remove the TORX® bolt, and then remove the inner seat belt assembly.

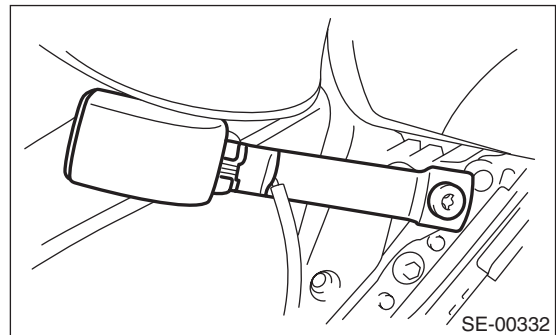

### **B: INSTALLATION**

Install in the reverse order of removal.

#### **CAUTION:**

- The parts of driver's seat and those of passenger's seat are not the same. Before installation, make sure that the correct part is used.
- Be careful not to twist the seat belts during installation.

#### ***Tightening torque:***

*<Ref. to SB-2, FRONT SEAT BELT, COMPONENT, General Description.>*

### **C: INSPECTION**

Check for the following, and replace with new parts if necessary.

- Pretensioner is cracked or deformed.
- Seat belt is slackened, bent or worn.
- Seat belt is abnormally wound or extended.
- Inner seat belt assembly is deformed or damaged.
- Seat belt buckle cannot be engaged properly.

Brought to you by Chris Studios  
NOT FOR SALE

## 6. Rear Seat Belt

### A: REMOVAL

#### 1. OUTER SEAT BELT ASSEMBLY RH & LH

- 1) Remove the luggage floor mat.
- 2) Remove the rear seat cushion. <Ref. to SE-11, REMOVAL, Rear Seat.>
- 3) Remove the seat belt lower anchor bolt.

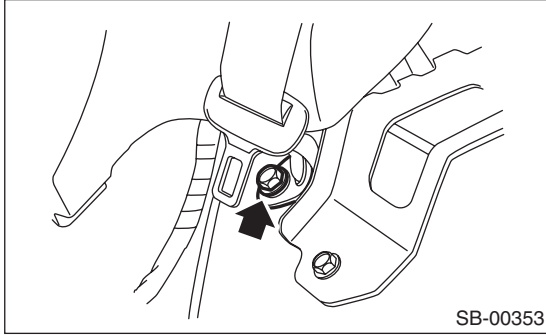

- 4) Remove the rear quarter trim. <Ref. to EI-55, REMOVAL, Rear Quarter Trim.>

- 5) Remove the outer belt assembly.

- Wagon model  
Remove the nut.

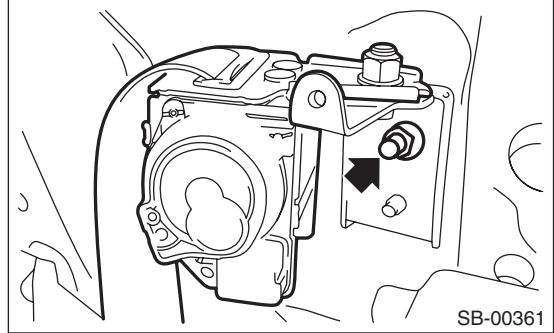

#### CAUTION:

Do not remove the bolt and nut securing the retractor and bracket.

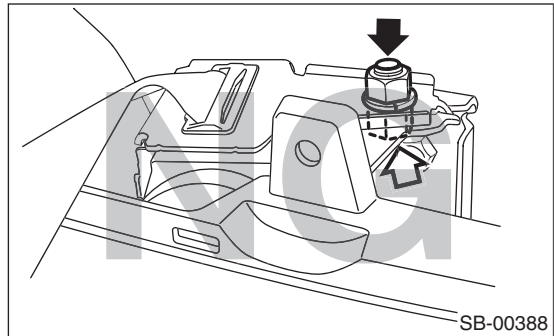

- Sedan model  
Remove the bolt.

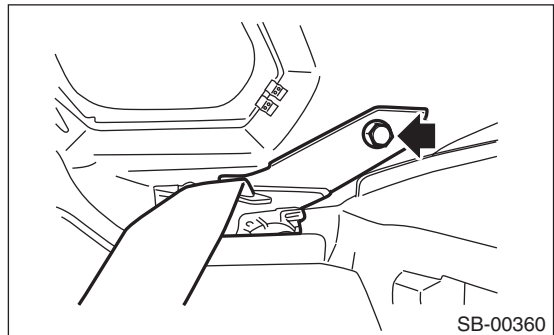

# Rear Seat Belt

Brought to you by Eris Studios  
NOT FOR RESALE

## SEAT BELT SYSTEM

### 2. SHOULDER SEAT BELT CENTER ASSEMBLY (WAGON MODEL)

- 1) Remove the shoulder anchor bolt cover (A).
- 2) Remove the shoulder anchor bolt (B), and then remove shoulder anchor from the quarter pillar.

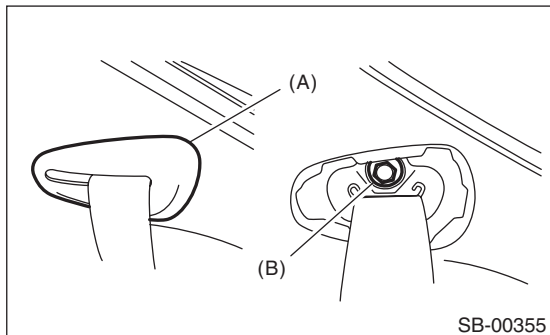

- 3) Remove the quarter trim. <Ref. to EI-55, REMOVAL, Rear Quarter Trim.>
- 4) Remove the bolts, then remove the outer belt center assembly.

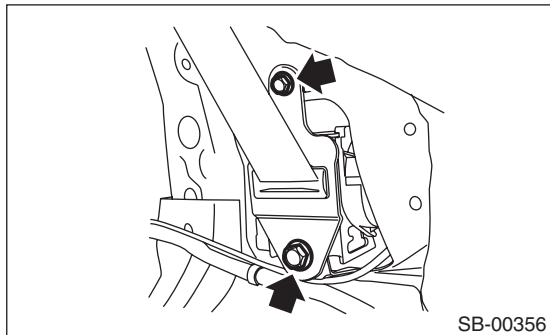

### 3. SHOULDER SEAT BELT CENTER ASSEMBLY (SEDAN MODEL)

- 1) Remove the rear seat. <Ref. to SE-11, REMOVAL, Rear Seat.>
- 2) Remove the rear quarter trim. <Ref. to EI-55, REMOVAL, Rear Quarter Trim.>
- 3) Remove the rear shelf trim. <Ref. to EI-57, REMOVAL, Rear Shelf Trim.>
- 4) Remove the bolts, then remove the shoulder seat belt assembly.

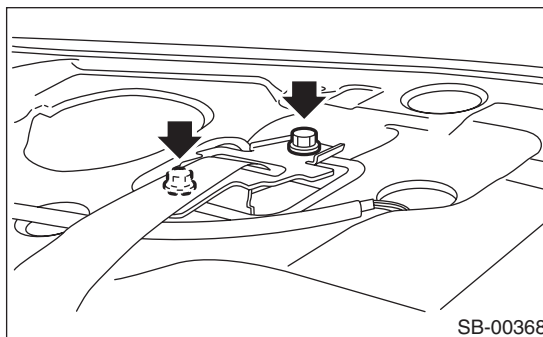

- 5) Remove the seat belt lower anchor bolt.

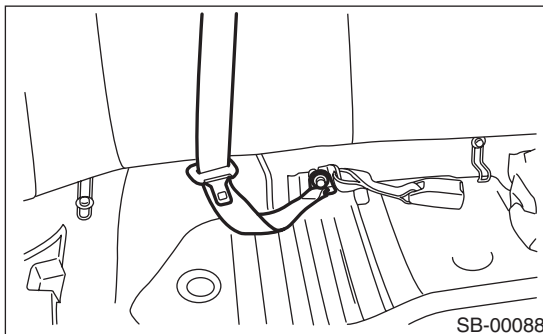

### 4. CENTER SEAT BELT ASSEMBLY

- 1) Remove the rear seat cushion.
- 2) Remove the bolts, then remove the center seat belt assembly.

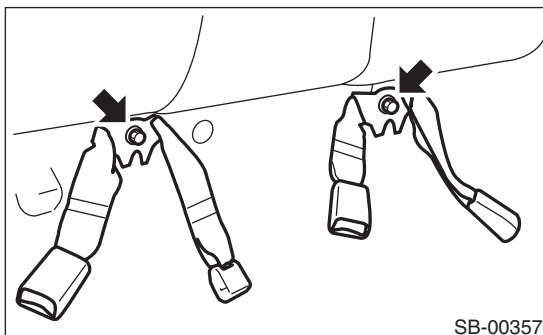

Brought to you by Peris Studios  
NOT FOR RESALE

## B: INSTALLATION

### CAUTION:

- During installation, make sure that the seat belts are not twisted.
- After installation, make sure that the seat belts are smoothly extended and wound.
- Check that the center seat belt is assembled correctly.

1) Install in the reverse order of removal.

### Tightening torque:

<Ref. to SB-3, REAR SEAT BELT, COMPONENT, General Description.>

2) Turn the seat belt as shown in the figure.

- LH side

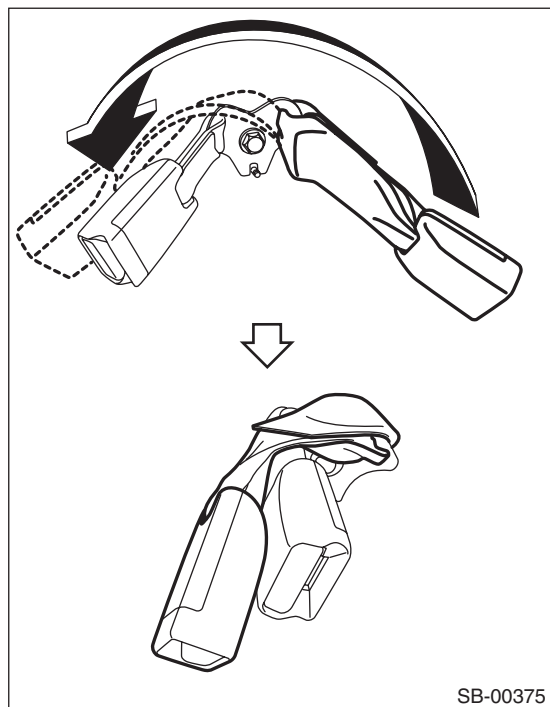

- RH side (Wagon model only)

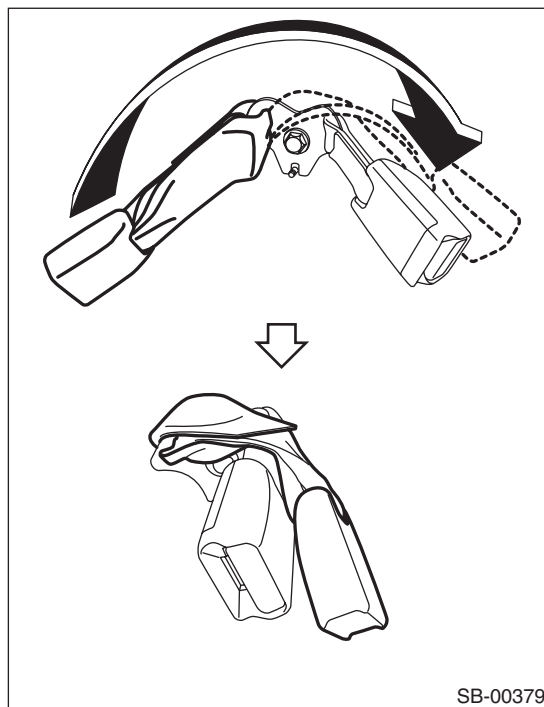

3) Install the seat cushion and pull out the center seat belt assembly.

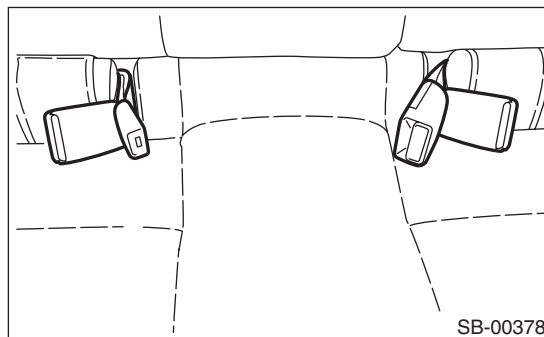

## C: INSPECTION

Check for the following, and replace with new parts if necessary.

- Seat belt is slackened, bent or worn.
- Seat belt is abnormally wound or extended.
- Inner seat belt is deformed or damaged.
- Seat belt buckle cannot be engaged properly.

# Rear Seat Belt

SEAT BELT SYSTEM

---

Brought to you by Eris Studios  
NOT FOR RESALE