

Brought to you by Eris Studios  
NOT FOR RESALE

# FRONT SUSPENSION

# General Description

Brought to you by Eris Studios  
NOT FOR RESALE

## FRONT SUSPENSION

### 1. General Description

#### A: SPECIFICATION

MODEL		OUTBACK	Non-turbo	Turbo	
FRONT	Wheel arch height (Tolerance: +12 mm -24 mm (+0.47 in -0.94 in))	392 (15.4)	387 (15.2)		
	Camber (Tolerance: $\pm 0^{\circ}45'$ Differences between RH and LH: 45' or less)	-0°05'	-0°10'		
	Caster (Referential Value)	5°50'	5°55'		
	Steering angle (Tolerance: $\pm 1.5^{\circ}$ )	Inner wheel	37.9°	37.8°	
		Outer wheel	33.5°	33.4°	
	Toe-in	mm (in)	0±3 (0±0.12) Toe angle (sum of both wheels): 0°±0°15'		
	Kingpin angle (Referential Value)		13°30'	13°35'	
Side slip	mm (in)	0±4 (0±0.16)			
REAR	Wheel arch height (Tolerance: +12 mm -24 mm (+0.47 in -0.94 in))	380 (15)	375 (14.8)		
	Camber (Tolerance: $\pm 0^{\circ}45'$ Differences between RH and LH: 45' or less)	-1°05'	-1°15'		
	Toe-in	mm (in)	0±3 (0±0.12) Toe angle (sum of both wheels): 0°±0°15'		
	Thrust angle (Tolerance: $\pm 0^{\circ}30'$ )		0°		

#### NOTE:

- Front and rear toe-in and front camber can be adjusted. Adjust if the toe-in or camber tolerance exceeds specifications.
- Other items indicated in the specifications is not equipped with adjustment mechanisms. If other items exceed specifications, check the suspension parts and connections for deformation, and replace with new parts as required.

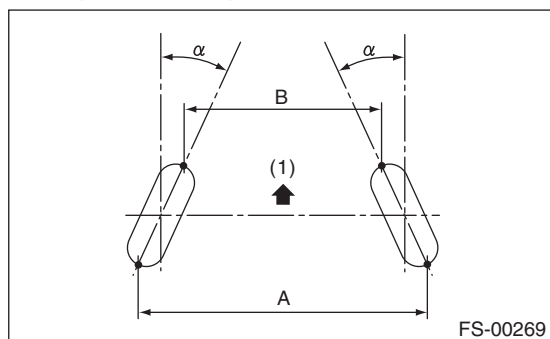

(1) Front

A - B = Positive: Toe-in, Negative: Toe-out  
 $\alpha$  = Individual toe angles

Brought to you by *Chris Studios*  
NOT FOR SALE

### B: COMPONENT

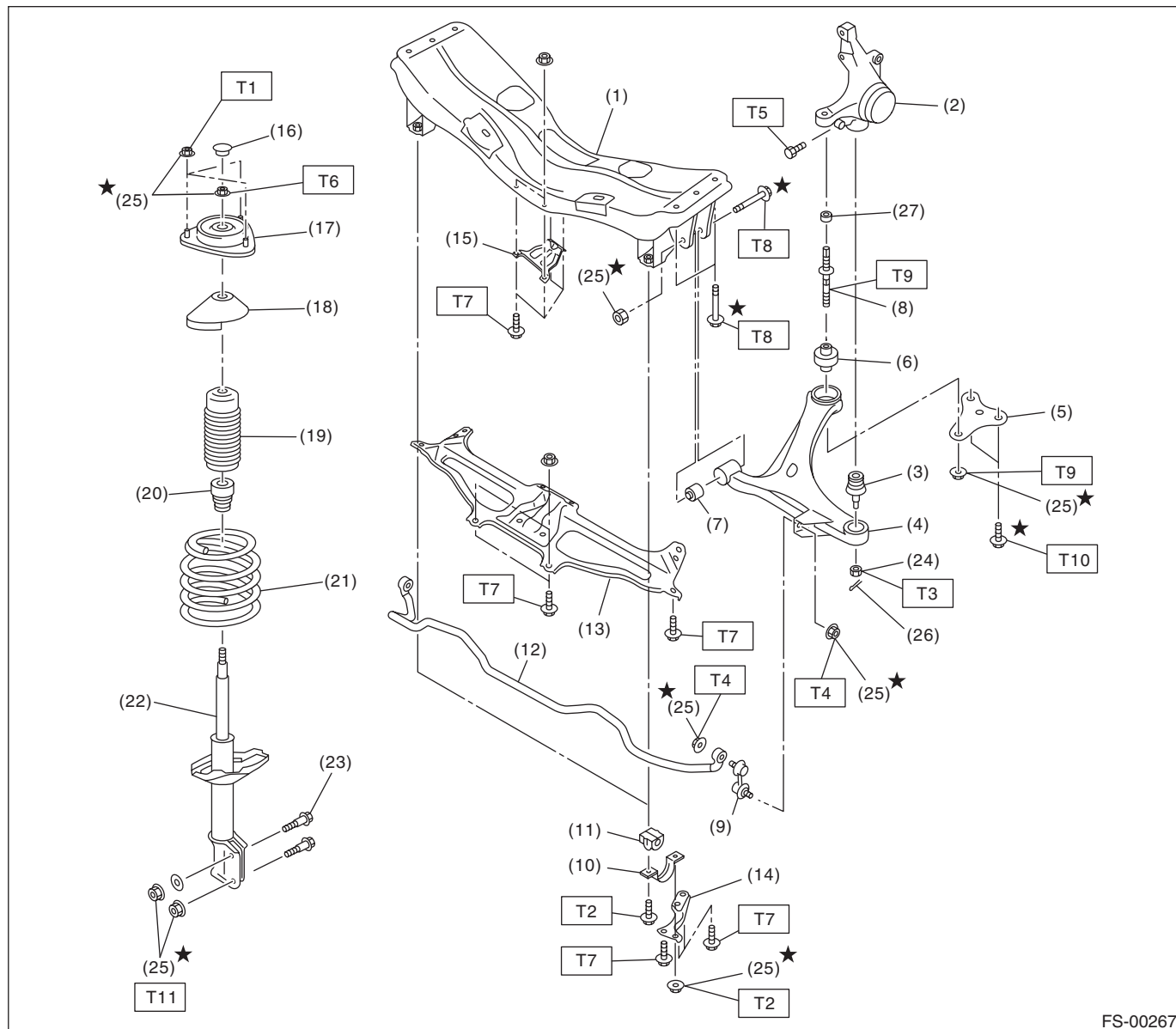

FS-00267

# General Description

Brought to you by Eris Studios  
NOT FOR RESALE

## FRONT SUSPENSION

(1) Front crossmember	(15) Jack-up plate	<b>Tightening torque:N-m (kgf-m, ft-lb)</b>	
(2) Housing	(16) Dust seal		<b>T1: 20 (2.0, 14.5)</b>
(3) Ball joint	(17) Strut mount		<b>T2: 25 (2.5, 18.4)</b>
(4) Front arm	(18) Upper spring seat		<b>T3: 39 (4.0, 28.8)</b>
(5) Support plate	(19) Dust cover		<b>T4: 45 (4.6, 33.2)</b>
(6) Rear bushing	(20) Helper		<b>T5: 50 (5.1, 36.9)</b>
(7) Front bushing	(21) Coil spring		<b>T6: 55 (5.6, 40.6)</b>
(8) Stud bolt	(22) Damper strut		<b>T7: 60 (6.1, 44.3)</b>
(9) Stabilizer link	(23) Adjusting bolt		<b>T8: 95 (9.7, 70.1)</b>
(10) Bracket	(24) Castle nut		<b>T9: 110 (11.2, 81.1)</b>
(11) Bushing	(25) Self-locking nut		<b>T10: 150 (15.3, 110.6)</b>
(12) Stabilizer	(26) Cotter pin	<b>T11: 175 (17.8, 129)</b>	
(13) Crossmember support plate (Large type)	(27) Stopper		
(14) Crossmember support plate (Small type)			

## C: CAUTION

- Wear appropriate work clothing, including a cap, protective goggles and protective shoes when performing any work.
- Before removal, installation or disassembly, be sure to clarify the failure. Avoid unnecessary removal, installation, disassembly and replacement.
- Use SUBARU genuine grease etc. or equivalent. Do not mix grease etc. of different grades or manufacturers.
- Before securing a part on a vise, place cushioning material such as wood blocks, aluminum plate, or cloth between the part and the vise.
- Be sure to tighten fasteners including bolts and nuts to the specified torque.
- Place shop jacks or rigid racks at the specified points.

## D: PREPARATION TOOL

### 1. SPECIAL TOOL

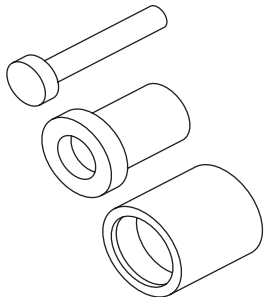
ILLUSTRATION	TOOL NUMBER	DESCRIPTION	REMARKS
 <p>ST-927680000</p>	927680000	INSTALLER & REMOVER SET	Used for replacing front arm front bushing.

# General Description

FRONT SUSPENSION

Brought to you by  
 NOT FOR SALE  
 Chris Studios

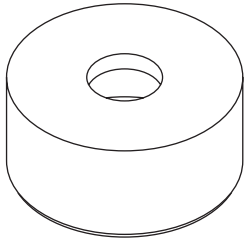
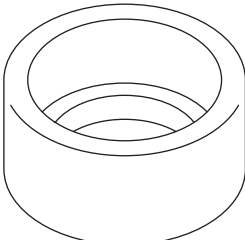
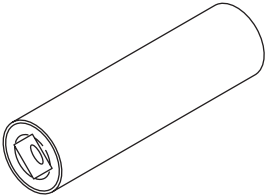
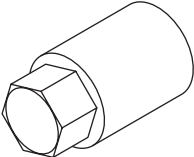
ILLUSTRATION	TOOL NUMBER	DESCRIPTION	REMARKS
 <p>ST20299AG000</p>	20299AG000	REMOVER	<ul style="list-style-type: none"> <li>Used for replacing front arm rear bushing.</li> <li>Used together with BASE (20999AG010).</li> </ul>
 <p>ST20299AG010</p>	20299AG010	BASE	<ul style="list-style-type: none"> <li>Used for replacing front arm rear bushing.</li> <li>Used together with REMOVER (20999AG000).</li> </ul>
 <p>ST20299AG020</p>	20299AG020	STUD BOLT SOCKET	Used for removing and installing the stud bolt for front arm installing portion.
 <p>ST20399AG000</p>	20399AG000	STRUT MOUNT SOCKET	Used for disassembling and assembling strut mount.

## 2. GENERAL TOOL

TOOL NAME	REMARKS
Alignment gauge	Used for measuring wheel alignment.
Alignment gauge adapter	Used for measuring wheel alignment.
Turning radius gauge	Used for measuring wheel alignment.
Toe-in gauge	Used for toe-in measurement.
Dial gauge	Used for damper strut measurement.
Coil spring compressor	Used for strut assembly/disassembly.
Side slip tester	Used for measuring side slip.

# Wheel Alignment

Brought to you by Eris Studios  
NOT FOR RESALE

## FRONT SUSPENSION

### 2. Wheel Alignment

#### A: INSPECTION

Check the following items before performing the wheel alignment measurement.

- Tire inflation pressure
- Uneven wear of RH and LH tires, or difference of sizes
- Tire runout
- Excessive play and wear of ball joint
- Excessive play and wear of tie rod end
- Excessive play of wheel bearing
- Right and left wheel base imbalance
- Deformation and excessive play of steering link
- Deformation and excessive play of suspension parts

Check, adjust and measure the wheel alignment in accordance with the procedures indicated in the figure.

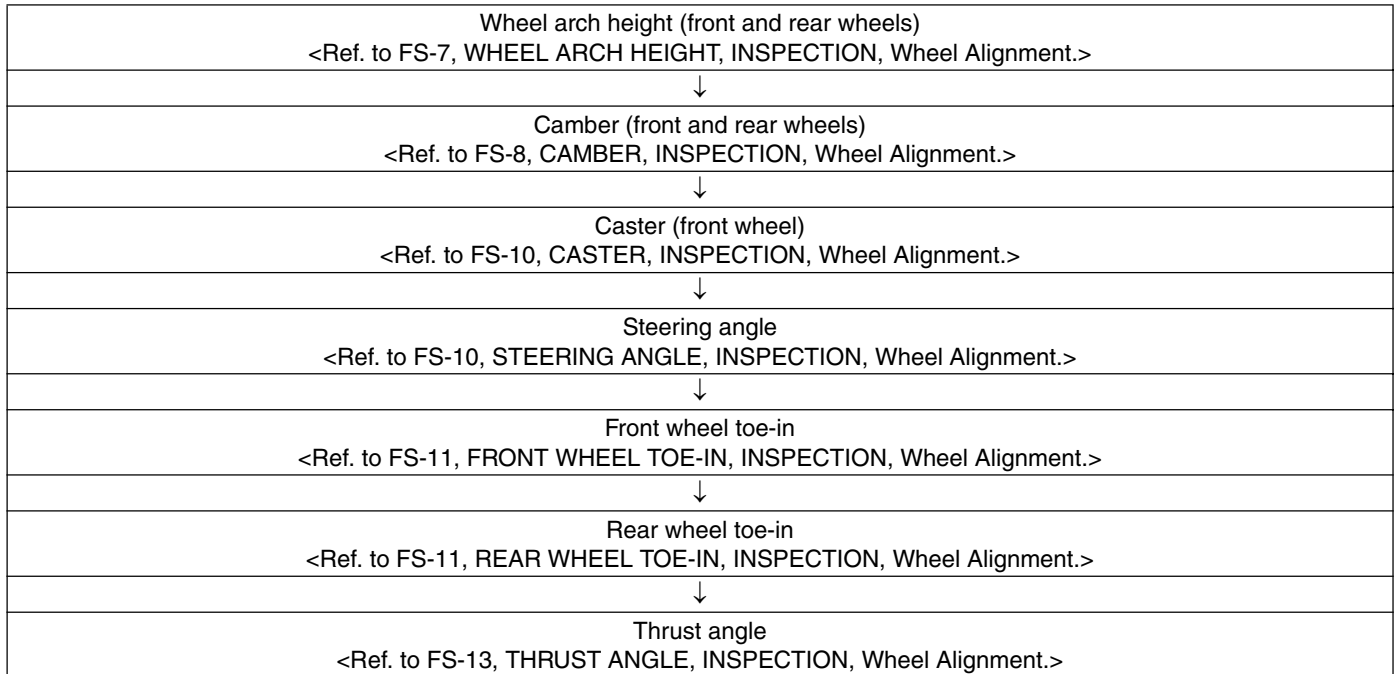

## 1. WHEEL ARCH HEIGHT

- 1) Park the vehicle on a level surface.
- 2) Empty the vehicle so that it is at “curb weight”. (Empty the luggage compartment, load the spare tire, jack and service tools, and fill up the fuel tank.)
- 3) Set the steering wheel in a straight-ahead position, and stabilize the suspensions by moving the vehicle in a straight line for 5 m (16 ft) or more.
- 4) Suspend a thread from the wheel arch (point “A” in the figure below) and affix at a position directly above the center of wheel.
- 5) Measure the distance between the point “A” and the center of wheel.

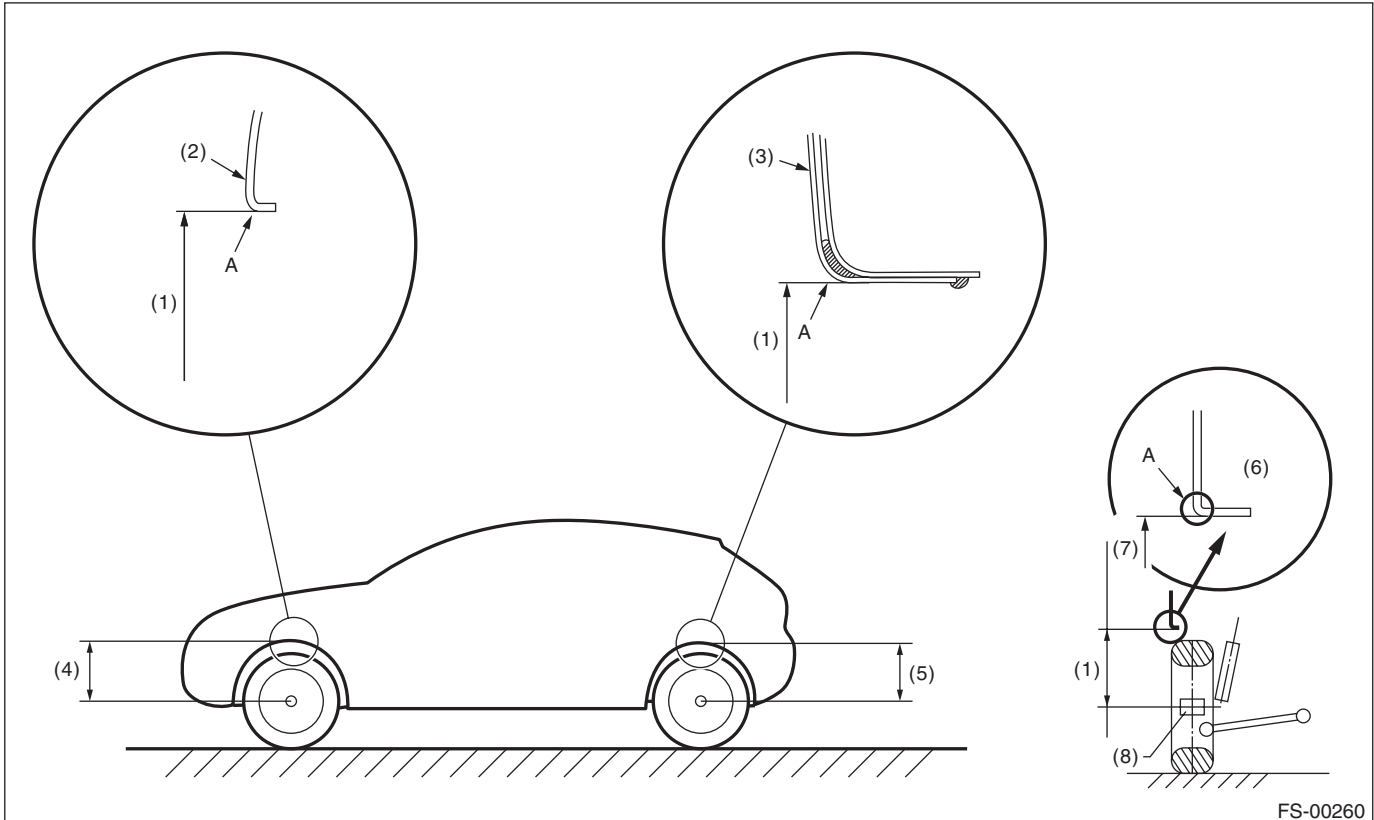

FS-00260

- |                       |                             |                          |
|-----------------------|-----------------------------|--------------------------|
| (1) Wheel arch height | (4) Front wheel arch height | (7) Point of measurement |
| (2) Front fender      | (5) Rear wheel arch height  | (8) End of spindle       |
| (3) Rear quarter      | (6) Flange bend line        |                          |

Wheel arch height specification mm (in) (Tolerance: +12 mm -24 mm (+0.47 in -0.94 in))			
Model	OUTBACK	Non-Turbo	Turbo
Front	392 (15.4)	387 (15.2)	
Rear	380 (15)		375 (14.8)

# Wheel Alignment

Brought to you by Eris Studios  
NOT FOR RESALE

## FRONT SUSPENSION

### 2. CAMBER

#### • Inspection

- 1) Place the front wheel on the turning radius gauge. Make sure the ground contact surfaces of the front and rear wheels are at the same height.
- 2) Set the adapter into the center of wheel, and then set the wheel alignment gauge.

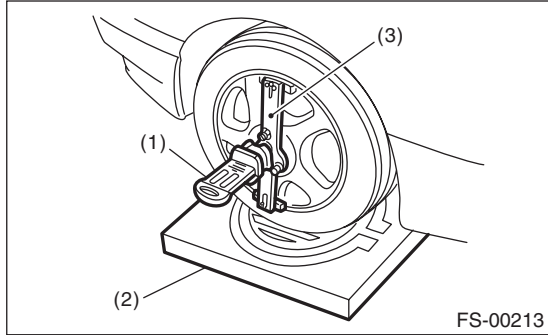

- (1) Alignment gauge
- (2) Turning radius gauge
- (3) Adapter

- 3) Measure the camber angle in accordance with the operation manual for wheel alignment gauge.

Model	Camber (Difference between RH and LH 45' or less)
Except for OUTBACK	$-0^{\circ}10' \pm 0^{\circ}45'$
OUTBACK	$-0^{\circ}05' \pm 0^{\circ}45'$

#### • FRONT CAMBER ADJUSTMENT

- 1) When adjusting the camber, adjust it to the following value.

Model	Camber (Difference between RH and LH 45' or less)
Except for OUTBACK	$-0^{\circ}10' \pm 0^{\circ}30'$
OUTBACK	$-0^{\circ}05' \pm 0^{\circ}30'$

- 2) Loosen the two self-locking nuts located at the front lower section of the strut.

#### NOTE:

When the adjusting bolt needs to be loosened or tightened, hold its head with a wrench and turn the self-locking nut.

- 3) Turn the camber adjusting bolt so that the camber is set at specification.

#### NOTE:

Moving the adjusting bolt by one scale changes the camber by approximately  $0^{\circ}15'$ .

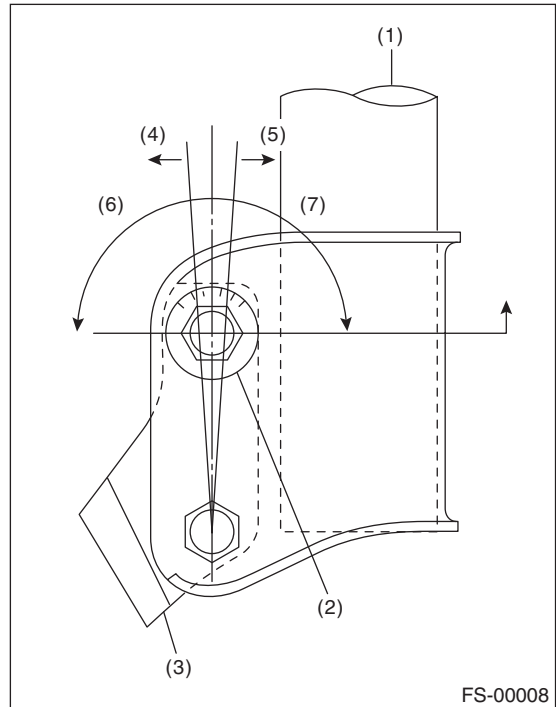

- (1) Strut
- (2) Adjusting bolt
- (3) Housing
- (4) Outer
- (5) Inner
- (6) Camber is increased.
- (7) Camber is decreased.



# Wheel Alignment

FRONT SUSPENSION

Brought to you by Eris Studios  
NOT FOR RESALE

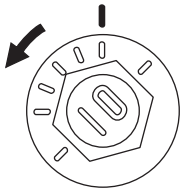
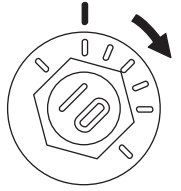
To increase camber.	
Rotate the left side counterclockwise.	Rotate the right side clockwise.
	
FS-00009	FS-00010

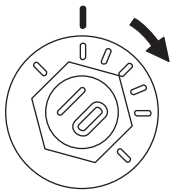
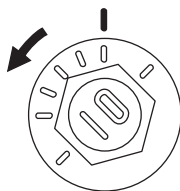
To decrease camber.	
Rotate the left side clockwise.	Rotate the right side counterclockwise.
	
FS-00010	FS-00009

4) Tighten two new self-locking nuts.

**Tightening torque:**

**175 N·m (17.8 kgf·m, 129 ft·lb)**

# Wheel Alignment

Brought to you by Eris Studios  
NOT FOR RESALE

## FRONT SUSPENSION

### 3. CASTER

#### • Inspection

- 1) Place the front wheel on the turning radius gauge. Make sure the ground contact surfaces of the front and rear wheels are at the same height.
- 2) Set the adapter into the center of wheel, and then set the wheel alignment gauge.

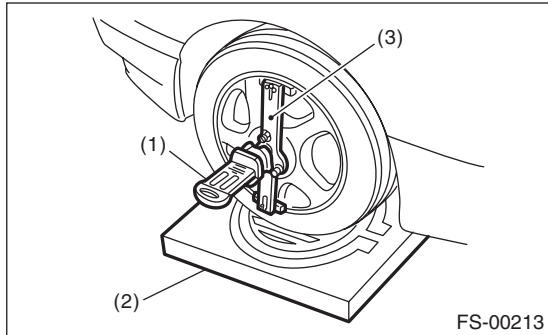

- (1) Alignment gauge
- (2) Turning radius gauge
- (3) Adapter

- 3) Measure the caster angle in accordance with the operation manual for wheel alignment gauge.

Model	Caster
Except for OUTBACK	5°55'
OUTBACK	5°50'

### 4. STEERING ANGLE

#### • Inspection

- 1) Place the vehicle on turning radius gauge.
- 2) While depressing the brake pedal, turn the steering wheel fully to the left and right. With the steering wheel held at each fully turned position, measure both the inner and outer wheel steering angles.

Model	Inner wheel	Outer wheel
Except for OUTBACK	37.8°±1.5°	33.4°±1.5°
OUTBACK	37.9°±1.5°	33.5°±1.5°

#### • ADJUSTMENT

- 1) Turn the tie-rod to adjust the steering angle of both inner and outer wheels.
- 2) Check the toe-in.

#### NOTE:

Correct the boot if it is twisted.

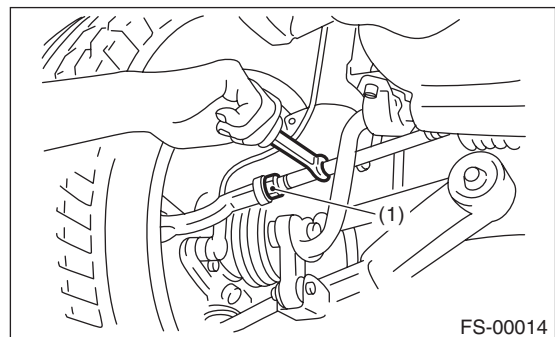

- (1) Lock nut

## 5. FRONT WHEEL TOE-IN

### • Inspection

#### Toe-in:

**$0 \pm 3 \text{ mm } (0 \pm 0.12 \text{ in})$**

- 1) Set the toe-in gauge in the position at wheel axis center height behind the right and left front tires.
- 2) Place a mark at the center of both left and right tires, and measure distance "A" between the marks.
- 3) Move the vehicle forward to rotate the tires  $180^\circ$ .

#### NOTE:

Be sure to rotate the tires in the forward direction.  
4) Measure the distance "B" between the left and right marks. Find toe-in using the following calculation:

$$A - B = \text{Toe-in}$$

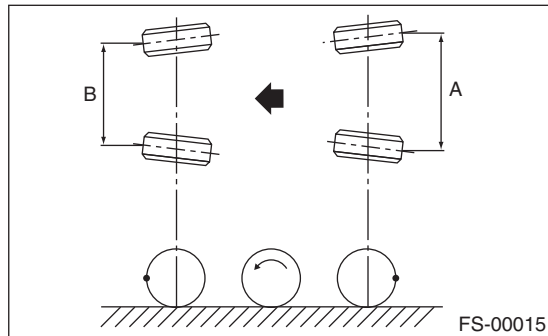

### • ADJUSTMENT

When adjusting the toe-in, adjust it to the following value.

#### Toe-in:

**$0 \pm 2 \text{ mm } (0 \pm 0.08 \text{ in})$**

- 1) Check that the left and right wheel steering angles are within specification.
  - 2) Loosen the left and right side steering tie-rod lock nuts.
  - 3) Turn the left and right tie-rods by equal amounts until the toe-in is at the specification.
- Both the left and right tie-rods are right-hand threaded. To increase toe-in, turn both tie-rods clockwise by equal amount (viewing from the inside of vehicle).

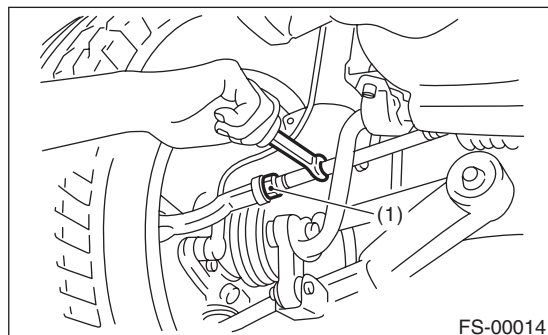

(1) Lock nut

- 4) Tighten the tie-rod lock nut.

#### Tightening torque:

**$85 \text{ N}\cdot\text{m } (8.7 \text{ kgf}\cdot\text{m}, 63 \text{ ft}\cdot\text{lb})$**

#### NOTE:

Check and correct the tie rod boot if twisted.

## 6. REAR WHEEL TOE-IN

### • Inspection

#### Toe-in:

**$0 \pm 3 \text{ mm } (0 \pm 0.12 \text{ in})$**

Refer to FRONT WHEEL TOE-IN for rear toe-in inspection procedures.

<Ref. to FS-11, FRONT WHEEL TOE-IN, INSPECTION, Wheel Alignment.>

### • ADJUSTMENT

When adjusting, adjust it to the following value.

#### Toe-in:

**$0 \pm 2 \text{ mm } (0 \pm 0.08 \text{ in})$**

- 1) Loosen the self-locking nut on the inner side of front lateral link.

#### NOTE:

When loosening or tightening the adjusting bolt, hold the bolt head and turn the self-locking nut.

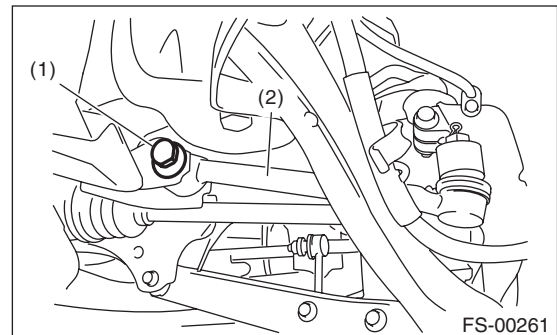

(1) Adjusting bolt

(2) Lateral link

# Wheel Alignment

Brought to you by Eris Studios  
NOT FOR RESALE

## FRONT SUSPENSION

2) Turn the adjusting bolt until toe-in is within the specification.

### NOTE:

When the left and right wheels are adjusted for toe-in at the same time, the movement of one scale graduation changes toe-in by approx. 1.3 mm (0.05 in).

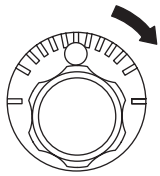
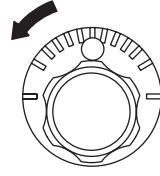
To increase toe-in.	
Rotate the left side clockwise.	Rotate the right side counterclockwise.
 FS-00018	 FS-00019

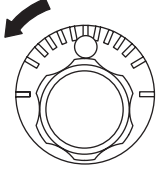
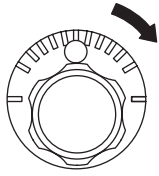
To decrease toe-in.	
Rotate the left side counterclockwise.	Rotate the right side clockwise.
 FS-00019	 FS-00018

3) Attach and tighten a new self-locking nut.

### Tightening torque:

**100 N·m (10.2 kgf·m, 73.8 ft-lb)**

## 7. THRUST ANGLE

### • Inspection

- 1) Park the vehicle on a level surface.
- 2) Move the vehicle 3 to 4 meters (10 to 13 feet) straight forward.
- 3) Draw the center of loci for both the front and rear axles.
- 4) Measure distance "L" between the center lines of the axle loci.

### Thrust angle

$0^{\circ} \pm 30'$

**Less than 30' when "L" is 23 mm (0.9 in) or less.**

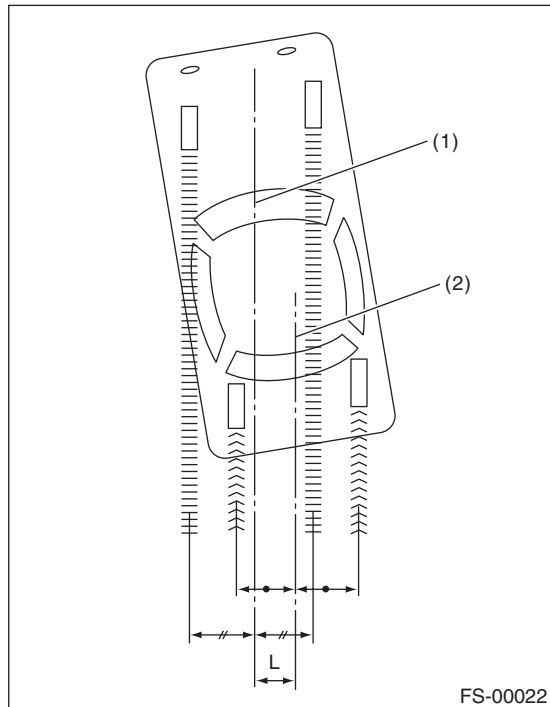

- (1) Center line of loci (front axle)
- (2) Center line of loci (rear axle)

### • ADJUSTMENT

When adjusting, adjust it to the following value.

### Thrust angle

$0^{\circ} \pm 20'$

**Less than 20' when "L" is 15 mm (0.6 in) or less.**

- 1) Make thrust angle adjustments by turning the toe-in adjusting bolts of the rear suspension equally in the same direction.
- 2) When one rear wheel is adjusted in a toe-in direction, adjust the other rear wheel equally in toe-out direction, in order to make the thrust angle adjustment.
- 3) When the left and right adjusting bolts are turned by one graduation, the thrust angle will change approx. 15' ("L" is approx. 11 mm (0.43 in)).

### NOTE:

Thrust angle is a mean value of left and right wheel toe angles in relation to the vehicle body center line. Vehicle is driven straight in the thrust angle direction while slanting in the oblique direction depending on the degree of the mean thrust angle.

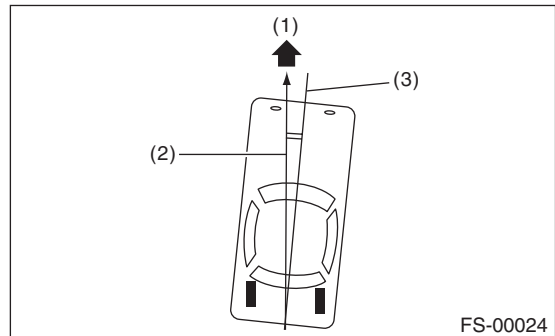

- (1) Front
- (2) Thrust angle
- (3) Body center line

### Thrust angle: $r = (\alpha - \beta)/2$

$\alpha$ : Rear RH wheel toe-in angle

$\beta$ : Rear LH wheel toe-in angle

Substitute only the positive toe-in values from each wheel into  $\alpha$  and  $\beta$  in the calculation.

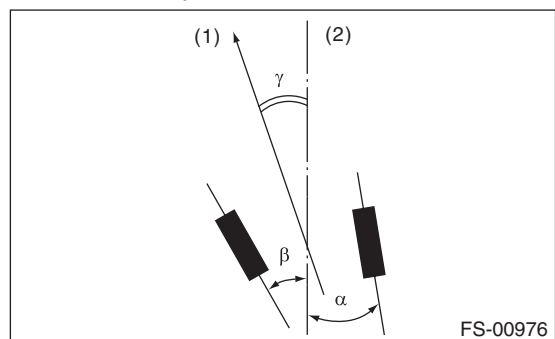

- (1) Front
- (2) Body center line

## 3. Front Crossmember Support Plate

### A: REMOVAL

- 1) Lift up the vehicle.
  - 2) Remove the front under cover. <Ref. to EI-26, REMOVAL, Front Under Cover.>
  - 3) Remove the bolt and remove front crossmember support plate.
- Large type (Turbo type)

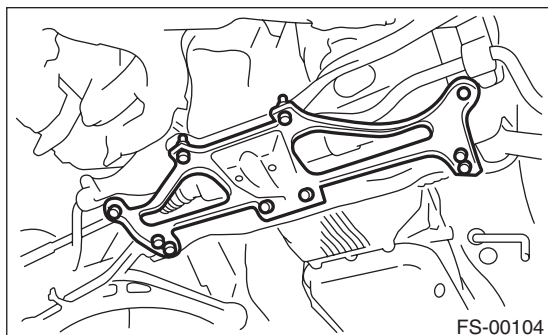

- Small type

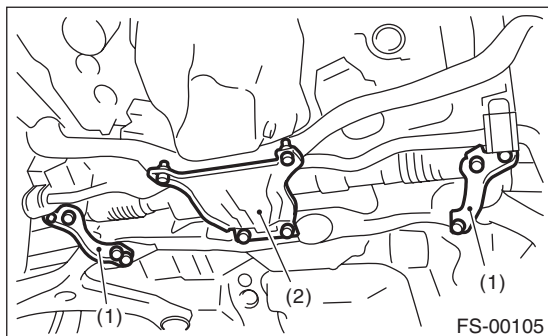

- (1) Crossmember support plate
- (2) Jack-up plate

### B: INSTALLATION

Install in the reverse order of removal.

#### NOTE:

Tighten the small type crossmember support plate together with stabilizer bracket.

After installing the stabilizer bracket to the crossmember, tighten the crossmember support plate together.

#### Tightening torque:

**Crossmember support plate:**

**60 N·m (6.1 kgf·m, 44.3 ft·lb)**

**Crossmember support plate (Tightened together with the stabilizer bracket):**

**25 N·m (2.5 kgf·m, 18.4 ft·lb)**

**Jack-up plate:**

**60 N·m (6.1 kgf·m, 44.3 ft·lb)**

## 4. Front Stabilizer

### A: REMOVAL

- 1) Lift up the vehicle, and then remove the front wheels.
- 2) Remove the front under cover. <Ref. to EI-26, REMOVAL, Front Under Cover.>
- 3) Remove the front crossmember support plate. <Ref. to FS-14, REMOVAL, Front Crossmember Support Plate.>
- 4) Remove the stabilizer link.



- 5) Remove the stabilizer bracket.

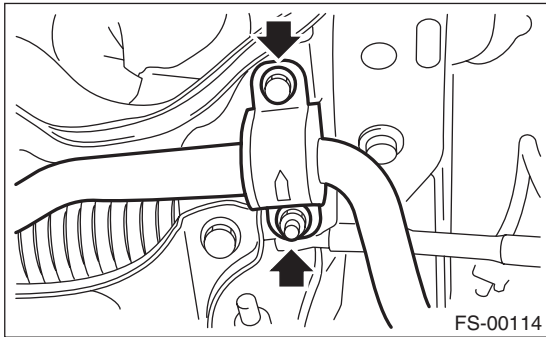

### B: INSTALLATION

Install in the reverse order of removal.

#### NOTE:

- Use a new self-locking nut.
- Ensure the stabilizer bushing and stabilizer have the same identification colors.
- Install the stabilizer bushing (front crossmember side) while aligning it with the paint mark on stabilizer.
- The stabilizer bracket has a set orientation. Install it with the arrow mark facing the upper side of the vehicle.

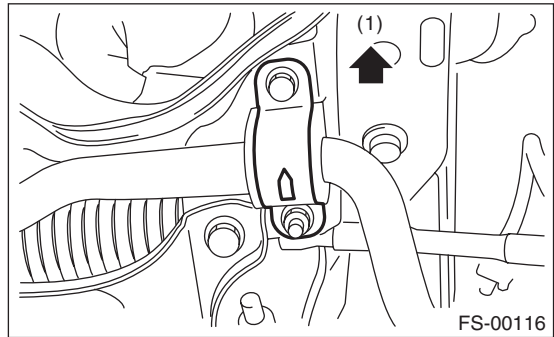

(1) Front side

#### **Tightening torque:**

##### **Stabilizer link:**

**45 N·m (4.6 kgf-m, 33.2 ft-lb)**

##### **Stabilizer bracket:**

**25 N·m (2.5 kgf-m, 18.4 ft-lb)**

### C: INSPECTION

- 1) Check the bushing for abnormal cracks, fatigue or damages.
- 2) Check the stabilizer link for damage.

## 5. Front Ball Joint

### A: REMOVAL

- 1) Lift up the vehicle, and remove the front wheels.
- 2) Remove the both sides of stabilizer bracket.

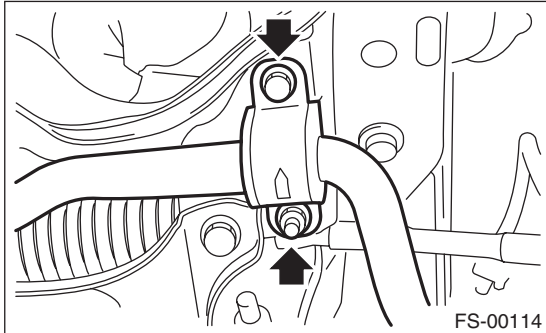

- 3) Pull out the pin from ball stud, remove the castle nut, and extract the ball stud from front arm.
- 4) Remove the bolt installing ball joint to housing.

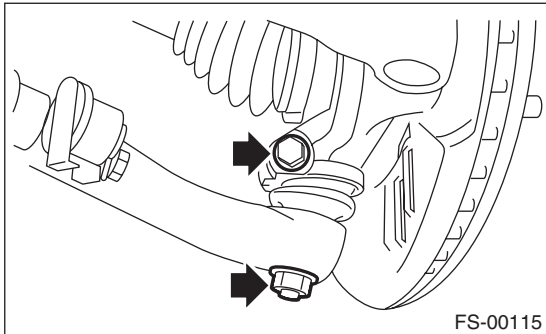

- 5) Extract the ball joint from housing.

### B: INSTALLATION

- 1) Insert the ball joint into housing.

**Tightening torque (Bolt):**  
**50 N·m (5.1 kgf-m, 36.9 ft-lb)**

#### CAUTION:

**Do not apply grease to the tapered portion of ball stud.**

- 2) Install the ball joint into front arm.

**Tightening torque (Castle nut):**  
**39 N·m (4.0 kgf-m, 28.8 ft-lb)**

3) Retighten the castle nut further up to 60° until the hole in the ball stud is aligned with a slot in castle nut. Then, insert a new cotter pin and bend it around the castle nut.

- 4) Install the stabilizer bracket.

#### NOTE:

The stabilizer bracket has a set orientation. Install it with the arrow mark facing the upper side of the vehicle.

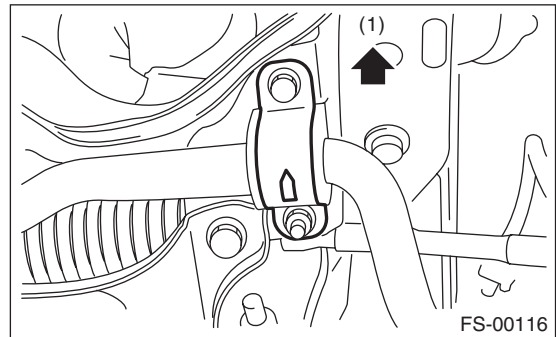

(1) Front side

**Tightening torque:**  
**25 N·m (2.5 kgf-m, 18.4 ft-lb)**

- 5) Install the front wheels.



## C: INSPECTION

1) Measure the play of the ball joint using the following procedures. Replace with a new part if the play exceeds specification.

(1) With 686 N (70 kgf, 154 lbf) loaded in direction shown in the figure, measure the length  $Q_1$ .

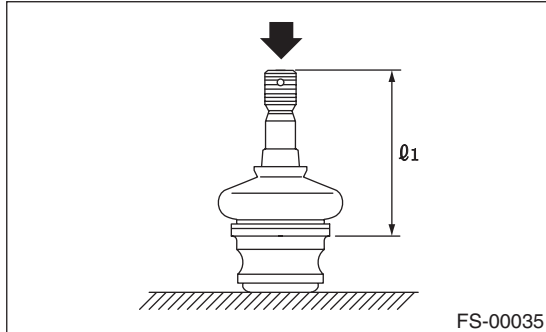

(2) With 686 N (70 kgf, 154 lbf) loaded in direction shown in the figure, measure the length  $Q_2$ .

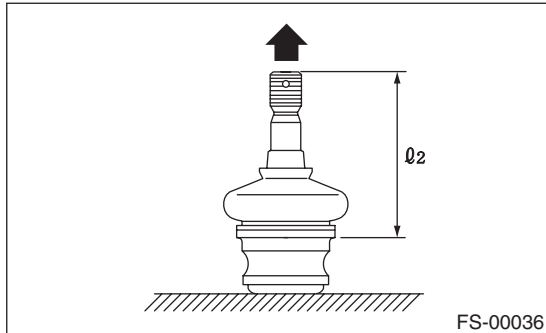

(3) Determine free play using the following formula.

$$S = Q_2 - Q_1$$

(4) Replace with a new part if the play exceeds specification.

### **Front ball joint**

#### **Specification for replacement S:**

**Less than 0.3 mm (0.012 in)**

- 2) If the play is within specification, visually check the dust cover.
- 3) Remove the ball joint and cover, and check for wear, damage or cracks. If any damage is found, replace the corresponding part.
- 4) If the dust cover is damaged, replace with a new ball joint.

## 6. Front Arm

### A: REMOVAL

- 1) Lift up the vehicle, and then remove the front wheels.
- 2) Remove the front crossmember support plate. <Ref. to FS-14, REMOVAL, Front Crossmember Support Plate.>
- 3) Remove the front stabilizer. <Ref. to FS-15, REMOVAL, Front Stabilizer.>
- 4) Remove the ball joint of front arm.

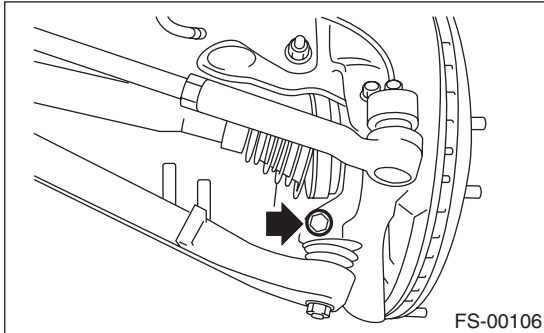

- 5) Remove the nut securing the front arm to crossmember. (Do not remove the bolt.)

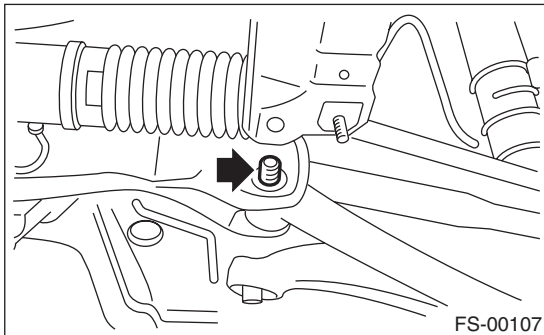

- 6) Remove the front arm support plate.

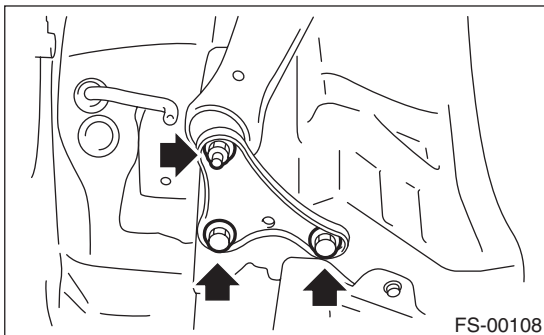

- 7) Remove the bolt securing front arm to crossmember and pull the front arm out of the crossmember.

- 8) To remove the stud bolt, use the ST.  
ST 20299AG020 STUD BOLT SOCKET

### CAUTION:

**Do not remove the stud bolt without necessity. Always replace the parts with new parts when removed.**

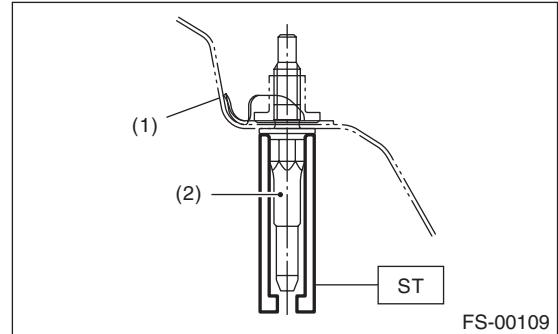

- (1) Vehicle body
- (2) Stud bolt

### B: INSTALLATION

- 1) Using the ST, install the stud bolt.  
ST 20299AG020 STUD BOLT SOCKET

#### Tightening torque:

**110 N·m (11.2 kgf-m, 81.1 ft-lb)**

- 2) Using new bolts and self-locking nuts, temporarily tighten the front arm to crossmember.
- 3) Secure the front arm to body, and then install the support plate with new bolts and self-locking nuts.

#### Tightening torque:

**Support plate to Front arm:**

**110 N·m (11.2 kgf-m, 81.1 ft-lb)**

**Support plate to Body:**

**150 N·m (15.3 kgf-m, 110.6 ft-lb)**

- 4) Install the ball joint into housing.

#### Tightening torque:

**50 N·m (5.1 kgf-m, 36.9 ft-lb)**

- 5) Install the stabilizer. <Ref. to FS-15, INSTALLATION, Front Stabilizer.>
- 6) Install the front wheels.
- 7) Lower the vehicle from lift, and tighten the bolt which secures the front arm to crossmember with wheels in full contact with the ground and the vehicle at curb weight.

#### Tightening torque:

**95 N·m (9.7 kgf-m, 70.1 ft-lb)**

- 8) Inspect the wheel alignment and adjust if necessary.

Brought to you by *Peris Studios*  
NOT FOR SALE

## C: DISASSEMBLY

### 1. FRONT BUSHING

Using the ST and a press, remove the front bushing.  
ST 927680000 INSTALLER & REMOVER SET

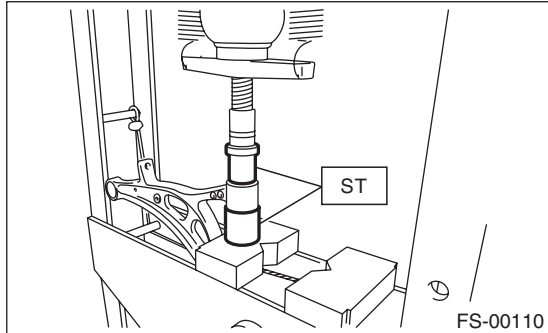

### 2. REAR BUSHING

1) Put an alignment mark on the front arm based on the center of rear bushing recess portion.

#### CAUTION:

Always put an alignment mark for aligning the position on bushing installation.

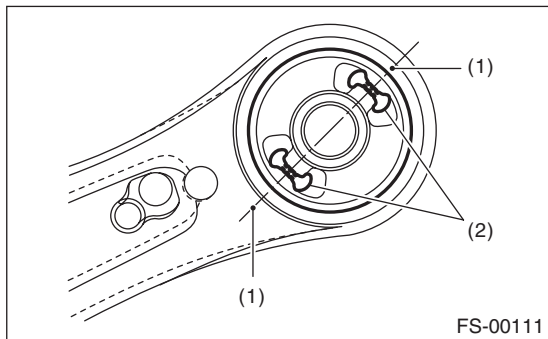

- (1) Put an alignment mark.
- (2) Recess section

2) Using the ST and a press, remove the rear bushing.

ST1 20299AG000 REMOVER  
ST2 20299AG010 BASE

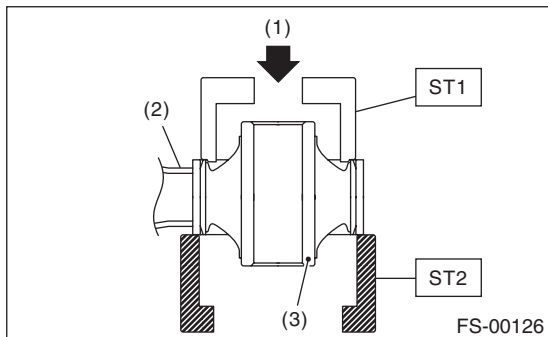

- (1) Press
- (2) Front arm
- (3) Rear bushing

## D: ASSEMBLY

### 1. FRONT BUSHING

Assemble in the reverse order of disassembly.

#### CAUTION:

Install the front bushing in proper direction as shown in the figure.

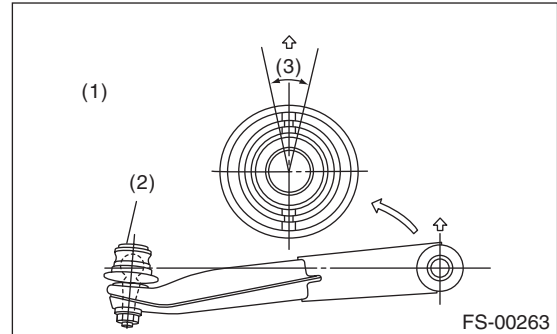

- (1) Face the bushing toward the center of ball joint.
- (2) Ball joint
- (3)  $\pm 3^\circ$

### 2. REAR BUSHING

1) Install the rear bushing with its longer inner cylinder facing upward and the shorter facing downward and protruding part rearward as shown in the figure.

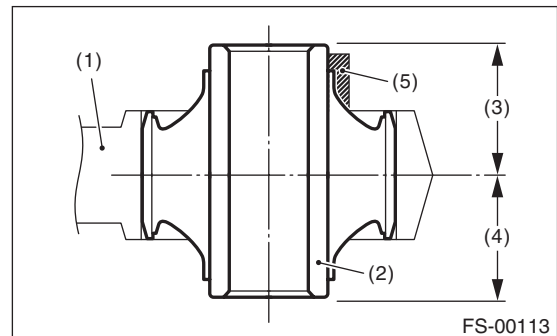

- (1) Front arm
- (2) Bushing inner cylinder
- (3) Longer
- (4) Shorter
- (5) Protrusion portion

# Front Arm

Brought to you by Eris Studios  
NOT FOR RESALE

## FRONT SUSPENSION

2) Align the center of rear bushing recess portion with the aligning mark on the front arm.

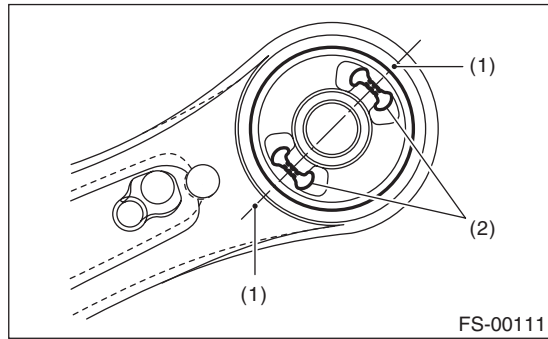

- (1) Alignment mark
- (2) Recess section

3) Using the ST and a press, install the rear bushing.

ST1 20299AG000 REMOVER  
ST2 20299AG010 BASE

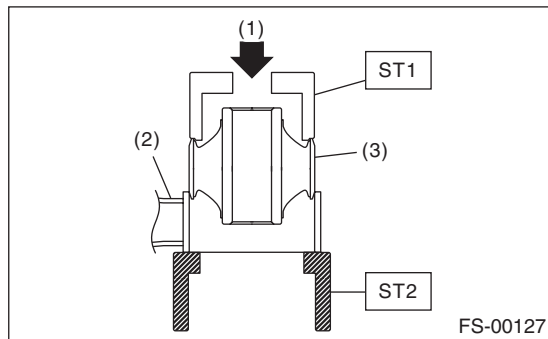

- (1) Press
- (2) Front arm
- (3) Rear bushing

## E: INSPECTION

- 1) Check the front arm for damage or cracks, and correct or replace if defective.
- 2) Check the bushing for abnormal fatigue or damage.

## 7. Front Strut

### A: REMOVAL

- 1) Lift up the vehicle, and then remove the front wheels.
- 2) Place an alignment mark on the camber adjusting bolt and strut.
- 3) Remove the bolt securing the brake hose from the strut.

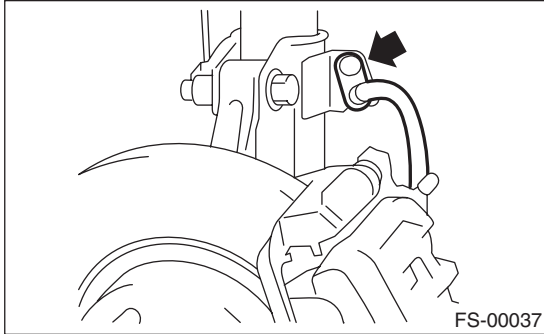

- 4) Remove the bolt securing the ABS wheel speed sensor harness.

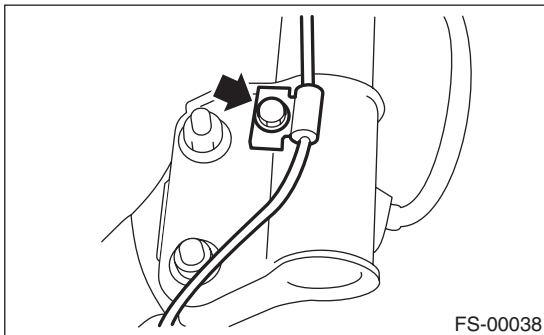

- 5) Remove the two bolts securing the housing to the strut.

**NOTE:**

While holding the head of the adjusting bolt, loosen the self-locking nut.

- 6) Remove the three nuts securing strut mount to body.

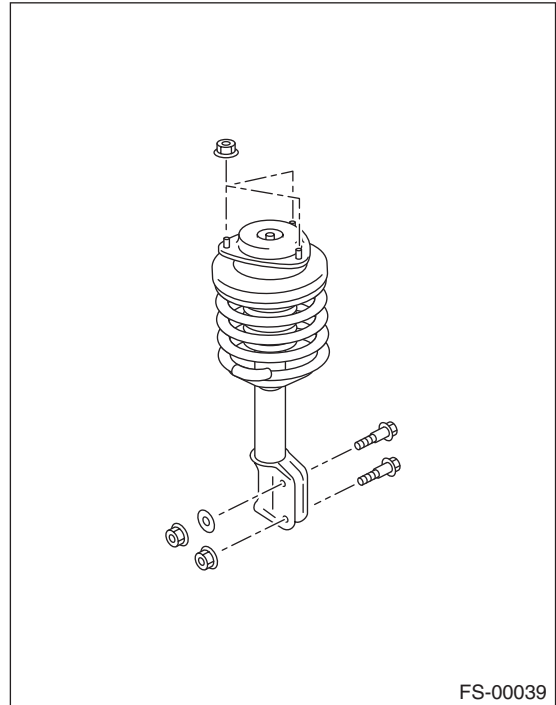

### B: INSTALLATION

- 1) Install the strut mount at the upper side of strut to body, and tighten it with new self-locking nuts.

**Tightening torque:**

**20 N·m (2.0 kgf-m, 14.5 ft-lb)**

- 2) Align alignment marks on the camber adjusting bolt and strut.

Using new self-locking nuts, install the strut to the housing.

**NOTE:**

While holding the head of adjusting bolt, tighten the self-locking nut.

**Tightening torque:**

**175 N·m (17.8 kgf-m, 129 ft-lb)**

- 3) Secure the ABS wheel speed sensor harness to the strut.

**Tightening torque:**

**33 N·m (3.4 kgf-m, 24.3 ft-lb)**

- 4) Install the bolts which secure the brake hose to the strut.

**Tightening torque:**

**33 N·m (3.4 kgf-m, 24.3 ft-lb)**

- 5) Install the front wheels.
- 6) Inspect the wheel alignment and adjust if necessary.

## FRONT SUSPENSION

### C: DISASSEMBLY

1) Using a coil spring compressor, compress the coil spring.

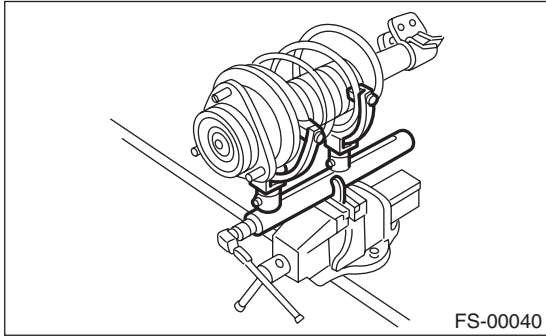

2) Using the ST, remove the self-locking nut.  
ST 20399AG000 STRUT MOUNT SOCKET

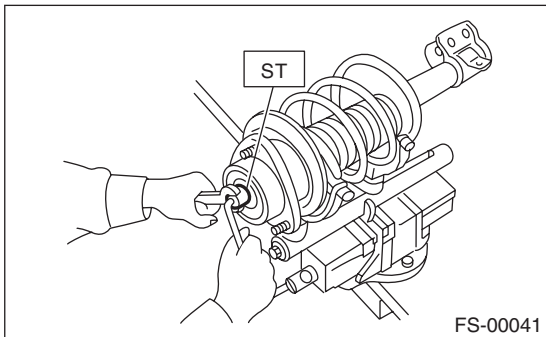

- 3) Remove the strut mount and upper spring seat from strut.
- 4) Gradually decrease the compression force of compressor, and remove the coil spring.
- 5) Remove the dust cover and helper spring.

### D: ASSEMBLY

1) Before installing the coil spring, strut mount, etc. on strut, check for the presence of air in the dampening force generating mechanism of the strut since air prevents proper dampening force production.

2) Checking for presence of air

- (1) Place the strut vertically with the piston rod facing up.
- (2) Move the piston rod to the center of its entire stroke.
- (3) While holding the piston rod end with fingers, move the rod up and down.
- (4) If the piston rod moves 10 mm (0.39 in) or more in the former step, purge air from the strut.

3) Air purging procedure

- (1) Place the strut vertically with the piston rod facing up.
- (2) Fully extend the piston rod.
- (3) With the piston rod fully extended, place the piston rod side down. The strut must stand vertically.
- (4) Fully retract the piston rod.
- (5) Repeat 3 or 4 times from the step (1).

#### NOTE:

After purging air from the strut, be sure to place the strut with the piston rod facing up. If the strut is laid down for any reason, check for the entry of air in accordance with "Checking for presence of air"

4) Using a coil spring compressor, compress the coil spring.

#### NOTE:

Make sure that the vertical install direction of the coil spring is as shown in the figure.

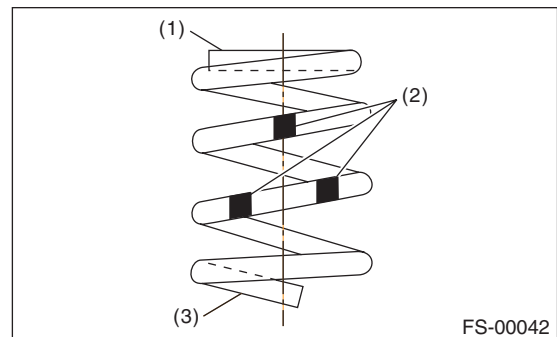

- (1) Diameter is small (Upper part)
- (2) Identification paint
- (3) Diameter is large (Bottom part)

5) Set the coil spring correctly so that its end face seats well in the spring seat as shown in the figure.

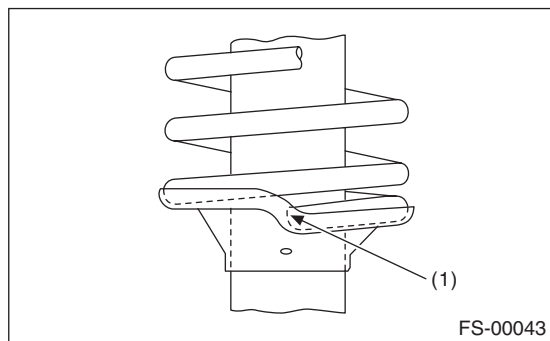

(1) Coil spring end face

6) Install the helper and dust cover to the piston rod.

7) Pull the piston rod fully upward, and install the spring seat.

**NOTE:**

Position the upper spring seat as shown in the figure.

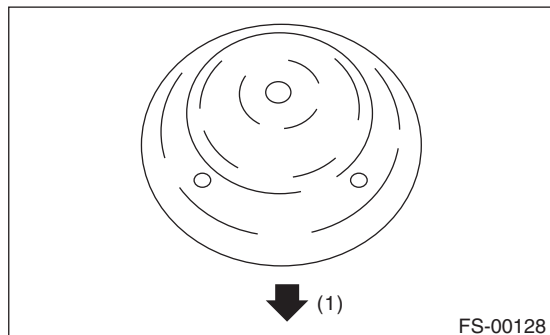

(1) Outside of body

8) Install the strut mount to piston rod, and temporarily attach and tighten a new self locking nut.

9) Using a hexagon wrench to prevent strut rod from turning, tighten the new self-locking nut with ST.

ST 20399AG000 STRUT MOUNT SOCKET

**Tightening torque:**

**55 N·m (5.6 kgf·m, 40.6 ft-lb)**

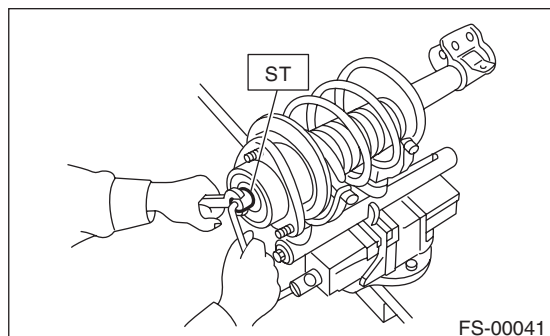

10) Loosen the coil spring compressor carefully.

## E: INSPECTION

Check the removed part for wear, damage and cracks, and then repair or replace it if defective.

### 1. DAMPER STRUT

1) Check for oil leaks.

2) Move the piston rod up and down to check that it operates smoothly without any hitch.

3) Piston rod play

- Measure the play as follows:

Fix the outer shell in place and fully extend the rod. Set a dial gauge at the end of rod L [10 mm (0.39 in)], and then read the dial gauge indication  $P_1$  while applying a force of W [20 N (2 kgf, 4 lbf)] to the threaded portion. Apply a force of 20 N (2 kgf, 4 lbf) from the opposite direction of "W", and then read the dial gauge indication  $P_2$ .

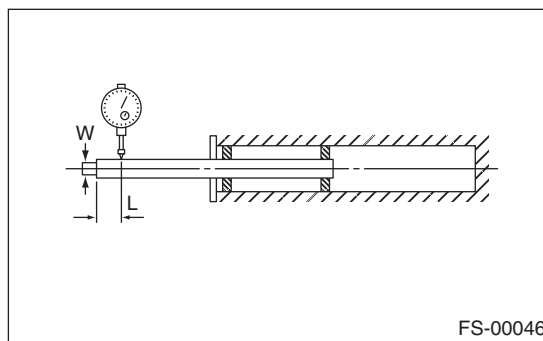

**Play limit ( $P_1 + P_2$ ):**  
**0.8 mm (0.031 in)**

If the play exceeds limit, replace the strut.

### 2. STRUT MOUNT

Check the rubber part for deformation, cracks or deterioration, and then replace it with a new part if defective.

### 3. DUST COVER

If major cracks or damage are found, replace it with a new part.

### 4. COIL SPRING

If a permanent strain is found, replaced it with a new part.

### 5. HELPER

If major cracks or damage are found, replace it with a new part.

### F: DISPOSAL

#### CAUTION:

- Before handling struts, be sure to wear goggles to protect eyes from gas, oil and cutting powder.
- Do not disassemble the strut damper or throw into flames.
- When discarding gas filled struts, drill holes in them to purge the gas.

1) Place the strut on a level surface with the piston rod fully expanded.

2) Using a 2 — 3 mm (0.08 — 0.12 in) dia. drill, make holes in areas shown in the figure.

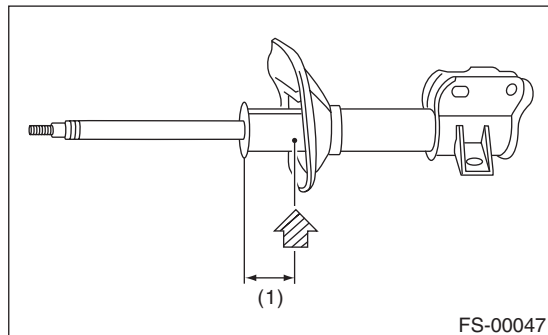

(1) 40 mm (1.57 in)



## 8. Front Crossmember

### A: REMOVAL

- 1) Lift up the vehicle, and then remove the front wheels.
- 2) Remove the front exhaust pipe.
- 3) Remove the front crossmember support plate. <Ref. to FS-14, REMOVAL, Front Crossmember Support Plate.>
- 4) Remove the front stabilizer. <Ref. to FS-15, REMOVAL, Front Stabilizer.>
- 5) Disconnect the tie-rod end from housing.
- 6) Remove the front arm. <Ref. to FS-18, REMOVAL, Front Arm.>
- 7) Remove the nuts attaching the engine mount cushion rubber to crossmember.

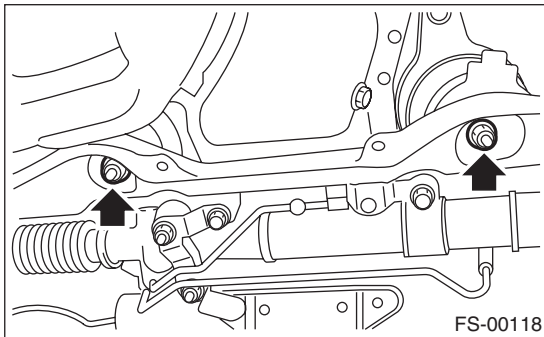

- 8) Remove the steering universal joint.
- 9) Disconnect the power steering hose from steering gearbox.
- 10) Lift the engine approx. 10 mm (0.39 in) using a chain block.
- 11) Support the crossmember with a jack, remove the bolts securing crossmember to body, and then gradually lower the crossmember with steering gearbox as a unit.

### CAUTION:

**When removing the crossmember downward, be careful that the tie-rod end does not interfere with drive shaft boot.**

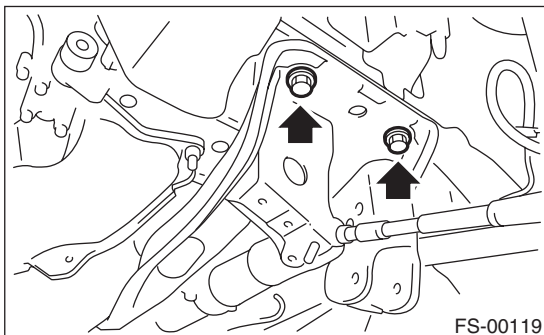

### B: INSTALLATION

- 1) Install in the reverse order of removal.

#### NOTE:

- Use a new bolt and self-locking nut. For parts which are not reusable, refer to "COMPONENT". <Ref. to FS-3, COMPONENT, General Description.>
- Always tighten the stabilizer bushing in the state where the vehicle is at curb weight and the wheels are in full contact with the ground.

#### Tightening torque:

##### **Crossmember to body:**

**95 N·m (9.7 kgf-m, 70.1 ft-lb)**

##### **Engine mounting to Crossmember:**

**85 N·m (8.7 kgf-m, 63 ft-lb)**

##### **Front arm to Crossmember:**

**95 N·m (9.7 kgf-m, 70.1 ft-lb)**

##### **Front arm to Support plate:**

**110 N·m (11.2 kgf-m, 81.1 ft-lb)**

##### **Support plate body:**

**150 N·m (15.3 kgf-m, 110.6 ft-lb)**

##### **Tie-rod end to Housing:**

**27.0 N·m (2.75 kgf-m, 19.9 ft-lb)**

After tightening to the specified torque, tighten the castle nut further but within 60° until the hole in the ball stud is aligned with a slot in castle nut

#### Tightening torque:

##### **Universal joint:**

**24 N·m (2.4 kgf-m, 17.4 ft-lb)**

##### **Stabilizer bracket:**

**25 N·m (2.5 kgf-m, 18.4 ft-lb)**

##### **Stabilizer link:**

**45 N·m (4.6 kgf-m, 33.2 ft-lb)**

##### **Power steering hose to Steering gearbox:**

**15 N·m (1.5 kgf-m, 10.8 ft-lb)**

- 2) Purge air from the power steering system.
- 3) Inspect the wheel alignment and adjust if necessary.

### C: INSPECTION

Check the crossmember for damage or cracks, and correct or replace if defective.

# General Diagnostic Table

## FRONT SUSPENSION

Brought to you by Eris Studios  
NOT FOR RESALE

### 9. General Diagnostic Table

#### A: INSPECTION

##### 1. IMPROPER VEHICLE POSTURE OR IMPROPER WHEEL ARCH HEIGHT

Possible cause	Corrective action
(1) Permanent distortion or damage of the coil spring	Replace.
(2) Rough operation of damper strut or shock absorber	Replace.
(3) Improper installation of strut or shock absorber	Replace with appropriate parts.
(4) Installation of the wrong coil spring	Replace with appropriate parts.

##### 2. POOR RIDE COMFORT

- 1) Large rebound shock
- 2) Rocking of the vehicle continues too long after running over bump and hump.
- 3) Excessive shock in bumping

Possible cause	Corrective action
(1) Damaged coil spring	Replace.
(2) Overinflation of tires	Adjust.
(3) Improper wheel arch height	Adjust or replace the coil springs with new parts.
(4) Fault in operation of damper strut or shock absorber	Replace.
(5) Damage or deformation of strut mount or shock absorber mount	Replace.
(6) Unsuitable length (maximum or minimum) of damper strut or shock absorber	Replace with appropriate parts.
(7) Deformation or loss of bushing	Replace.
(8) Deformation or damage of helper in strut assembly or shock absorber	Replace.
(9) Oil leakage from the damper strut or shock absorber	Replace.

##### 3. NOISE

Possible cause	Corrective action
(1) Wear or damage of damper strut or shock absorber component parts	Replace.
(2) Loosening of the suspension link installing bolt	Tighten to the specified torque.
(3) Deformation or loss of bushing	Replace.
(4) Unsuitable length (maximum or minimum) of damper strut or shock absorber	Replace with appropriate parts.
(5) Damaged coil spring	Replace.
(6) Wear or damage of the ball joint	Replace.
(7) Deformation of the stabilizer clamp	Replace.