

Brought to you by Eris Studios
NOT FOR RESALE

PARKING BRAKE

General Description

Brought to you by Eris Studios
NOT FOR RESALE

PARKING BRAKE

1. General Description

A: SPECIFICATION

Model		Rear Drum Brake	Rear disc brake
Type		Rear brake mechanical	Mechanical, drum in disc rear brakes
Effective drum diameter	mm (in)	254 (10)	190 (7.48)
Lining dimensions (Length x Width x Thickness)	mm (in)	243.8 x 40.0 x 4.5 (9.6 x 1.575 x 0.177)	165.8 x 30.0 x 2.8 (6.53 x 1.181 x 0.11)
Clearance adjustment		Automatic adjusting	Manual adjustment
Lever stroke	Notches/N (kgf, lbf)	7 — 8/200 (20.4, 45)	

B: COMPONENT

1. PARKING BRAKE (REAR DISC BRAKE)

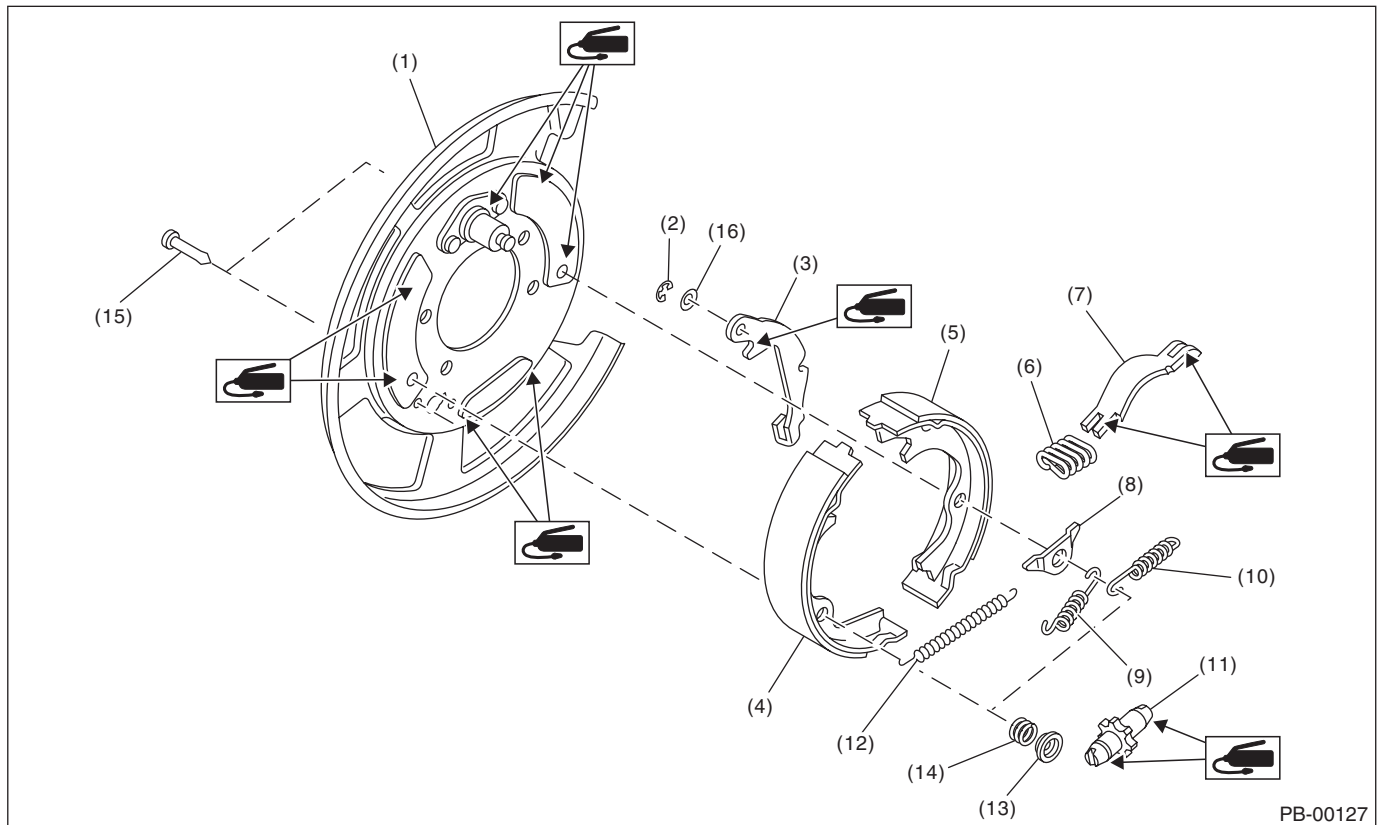

- | | | |
|------------------------------------|---------------------------------------|----------------------------|
| (1) Back plate | (7) Strut | (12) Adjusting spring |
| (2) Retainer | (8) Shoe guide plate | (13) Shoe hold-down cup |
| (3) Lever | (9) Primary return spring (blue) | (14) Shoe hold-down spring |
| (4) Parking brake shoe (Primary) | (10) Secondary return spring (yellow) | (15) Shoe hold-down pin |
| (5) Parking brake shoe (Secondary) | (11) Adjuster | (16) Wave washer |
| (6) Strut spring | | |

2. PARKING BRAKE CABLE

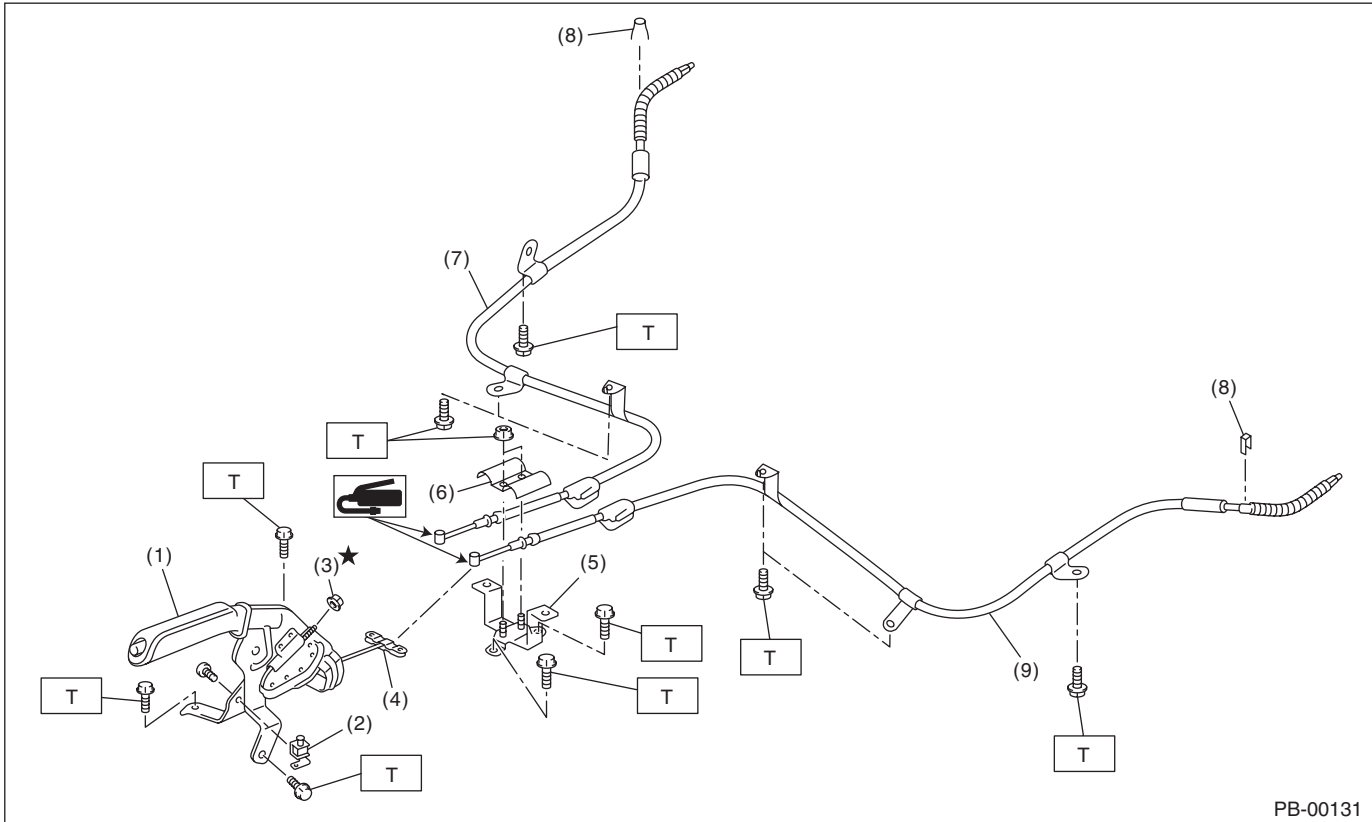

PB-00131

- | | | |
|--------------------------------------|----------------------------|----------------------------|
| (1) Parking brake lever | (5) Bracket | (9) Parking brake cable LH |
| (2) Parking brake switch | (6) Clamp | |
| (3) Adjusting nut (Self-locking nut) | (7) Parking brake cable RH | |
| (4) Equalizer | (8) Clamp | |

Tightening torque: N·m (kgf·m, ft·lb)
T: 18 (1.8, 13)

C: CAUTION

- Wear appropriate work clothing, including a cap, protective goggles and protective shoes when performing any work.
- Before removal, installation or disassembly, be sure to clarify the failure. Avoid unnecessary removal, installation, disassembly and replacement.
- Vehicle components are extremely hot after driving. Be wary of receiving burns from heated parts.
- Use SUBARU genuine grease etc. or equivalent. Do not mix grease etc. of different grades or manufacturers.
- Be sure to tighten fasteners including bolts and nuts to the specified torque.
- Place shop jacks or rigid racks at the specified points.
- Make sure grease does not come into contact with the parking shoes.

2. Parking Brake Lever

A: REMOVAL

- 1) Set the wheel stoppers to tires.
- 2) Remove the console box.
- 3) Disconnect the parking brake switch connector.
- 4) Remove the parking cable adjusting nut (self-locking nut).
- 5) Remove the parking brake lever.

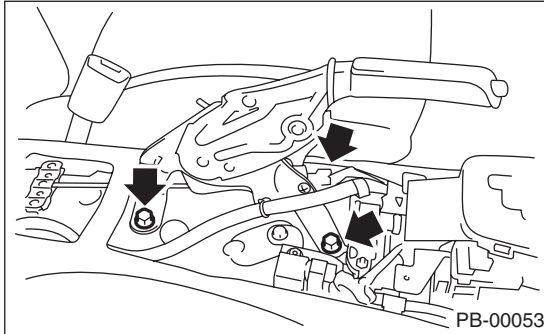

B: INSTALLATION

- 1) Install in the reverse order of removal.

Tightening torque:

Parking brake lever

18 N·m (1.8 kgf-m, 13 ft-lb)

- 2) Install a new adjusting nut (self-locking nut).
- 3) Be sure to adjust the lever stroke. <Ref. to PB-4, ADJUSTMENT, Parking Brake Lever.>

C: INSPECTION

- 1) Operate the parking brake lever 3 to 4 times and fully return the lever.
- 2) While slowly pulling the parking brake lever upward, count the notches.

Lever stroke:

7 to 8 notches when pulled with a force of 200 N (20.4 kgf, 45 lbf)

If it is not within the specified value, adjust the parking brake. <Ref. to PB-8, ADJUSTMENT, Parking Brake Assembly (Rear Disc Brake).>

D: ADJUSTMENT

Adjust the parking lever stroke. <Ref. to PB-8, LEVER STROKE, ADJUSTMENT, Parking Brake Assembly (Rear Disc Brake).>

3. Parking Brake Cable

A: REMOVAL

- 1) Remove the rear seat cushion.
- 2) Remove the console box.
- 3) Remove the parking cable adjusting nut (self-locking nut).
- 4) Remove the parking brake lever. <Ref. to PB-4, REMOVAL, Parking Brake Lever.>
- 5) Roll up the floor mat and remove the clamps.

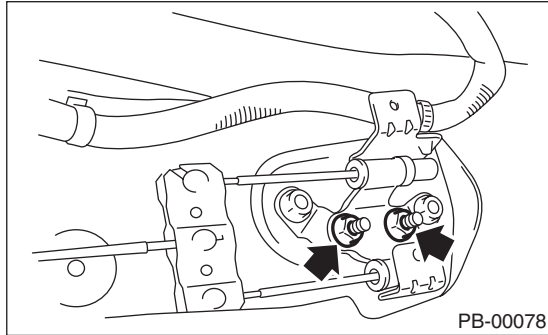

- 6) Remove the inner cable end from equalizer.

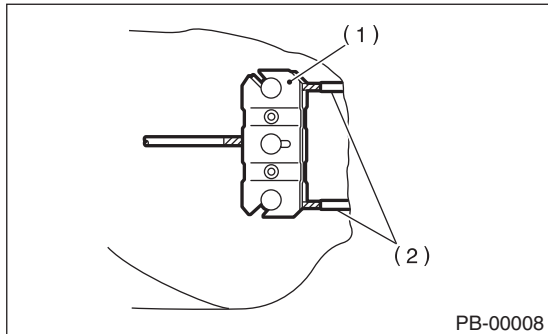

- (1) Equalizer
- (2) Inner cable end

- 7) Lift up the vehicle, and then remove the rear wheels.
- 8) Remove the parking brake cable from rear brake. <Ref. to PB-6, REMOVAL, Parking Brake Assembly (Rear Disc Brake).> <Ref. to BR-27, REMOVAL, Rear Drum Brake Shoe.>
- 9) Remove the clamp from the rear brake.
- 10) Remove the cable clamp from the rear arm bracket.
- 11) Remove the cable clamp from rear floor.

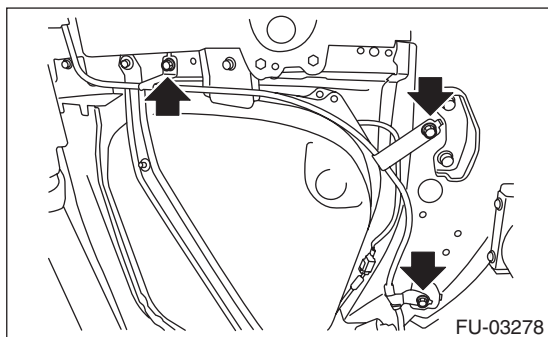

- 12) Remove the grommet from the rear floor, and remove the cable assembly.

B: INSTALLATION

- 1) Install in the reverse order of removal.

NOTE:

- Be sure to pass the cable through the tunnel in the cable guide.
- 2) Be sure to adjust the lever stroke. <Ref. to PB-4, ADJUSTMENT, Parking Brake Lever.>

C: INSPECTION

Check and replace the removed cable if damaged, rusty or faulty.

- 1) Check the cable for smooth operation.
- 2) Check the inner cable for damage and rust.
- 3) Check the outer cable for damage, bends and cracks.
- 4) Check the boot for damage, cracks, and corrosion.

Parking Brake Assembly (Rear Disc Brake)

Brought to you by Eris Studios
NOT FOR RESALE

PARKING BRAKE

4. Parking Brake Assembly (Rear Disc Brake)

A: REMOVAL

- 1) Release the parking brake.
- 2) Lift up the vehicle, and then remove the rear wheels.
- 3) Remove the brake hose bracket.

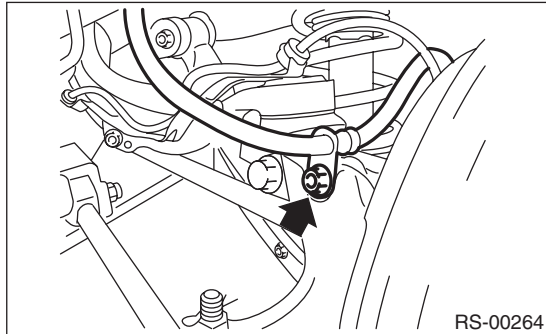

- 4) Remove the two mounting bolts and remove the rear disc brake caliper.

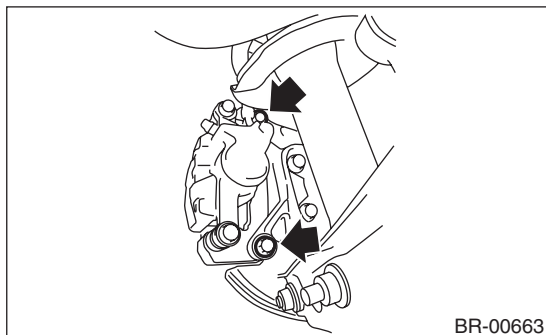

- 5) Suspend the rear disc brake caliper so that the brake hose is not stretched.
- 6) Remove the rear disc brake rotor.

NOTE:

If the disc rotor is difficult to remove, try the following two methods in order.

- (1) Turn the adjusting screw using a flat tip screwdriver until the brake shoe moves adequately away from the disc rotor.

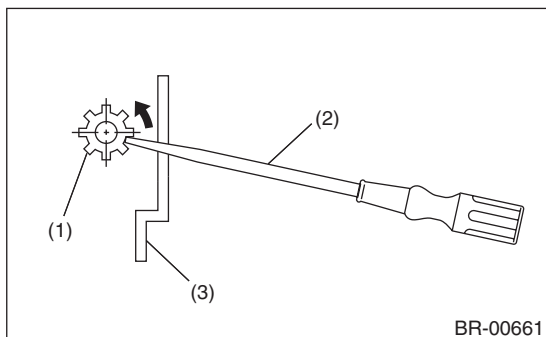

- (1) Adjuster
- (2) Flat tip screwdriver
- (3) Disc rotor

- (2) If disc rotor is seized on the hub, drive the disc rotor out by pushing two 8 mm bolts in holes B on the rotor.

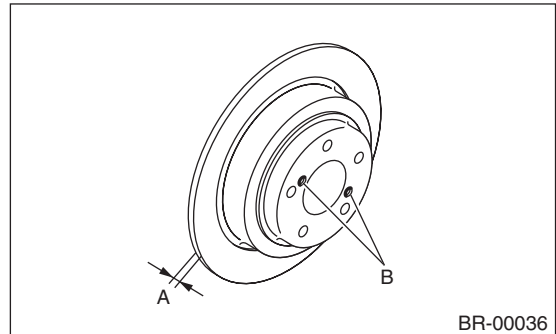

- 7) Remove the shoe return spring.

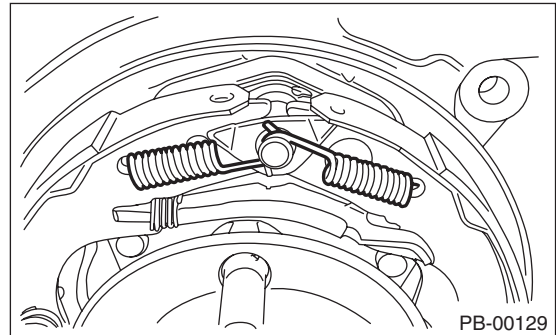

- 8) Remove the brake shoe cup and brake shoe spring, and remove the primary brake shoe.

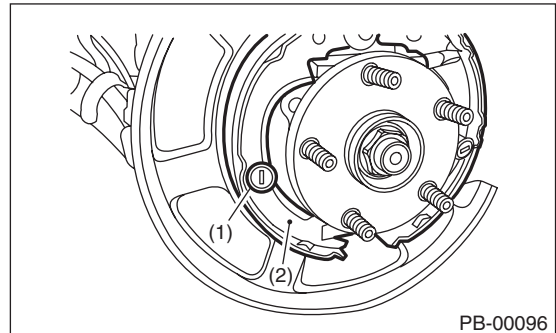

- (1) Brake shoe cup
- (2) Primary brake shoe

- 9) Remove the strut and strut spring.
- 10) Remove the adjuster.
- 11) Remove brake shoe cup and brake shoe spring, and remove the secondary brake shoe.

Parking Brake Assembly (Rear Disc Brake)

PARKING BRAKE

Brought to you by
NOT FOR SALE
Eris Studios

12) Remove the parking brake cable from lever.

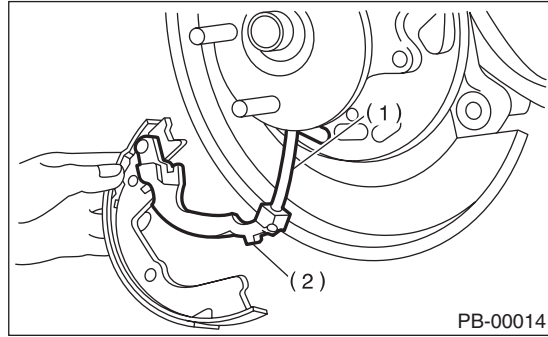

- (1) Parking brake cable
- (2) Lever

13) Remove a retainer from the secondary side brake shoe. Remove the lever from the brake shoe.

B: INSTALLATION

CAUTION:

Be sure the lining surface is free from brake fluid and grease.

1) Apply brake grease to the following locations.

Brake grease:

Brake Grease (Part No. 003602002)

- Six contact surfaces of the brake shoe rim and back plate gasket
- Contact surface of the brake shoe and the anchor pin
- Contact surface of the parking brake lever and strut
- Contact surface of the brake shoe and the adjuster
- Contact surface of the brake shoe and strut
- Contact surface of lever and brake shoe

2) Install the wave washer and lever to the secondary side brake shoe pin, and lock the retainer securely.

3) Install the parking brake cable to the lever.

4) Install the adjuster and adjusting spring to the brake shoe.

NOTE:

Install the adjuster with screw section on the front side of vehicle.

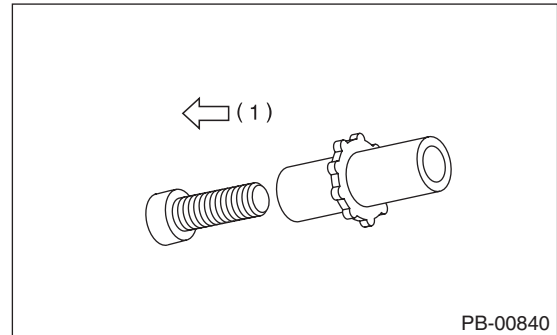

- (1) Front side

5) Check that the parking brake cable does not fall from the cable guide.

6) Install the brake shoes to the back plate with shoe hold pins, brake shoe springs, and brake shoe cups.

7) Install the strut and strut spring to the brake shoes.

NOTE:

Install the strut springs on the front side of the vehicle.

8) Install the return springs; first the primary side (blue) then the secondary side (yellow).

9) Adjust the parking brake. <Ref. to PB-8, ADJUSTMENT, Parking Brake Assembly (Rear Disc Brake).>

10) If new brake shoes are replaced, drive the vehicle to break-in the parking brake lining.

- (1) Drive the vehicle at about 35 km/h (22 MPH).
- (2) With the parking brake lever button pushed in, pull the parking brake lever gently.
- (3) Drive the vehicle for about 200 m (0.12 mile) in this condition.
- (4) Wait 5 to 10 minutes for the parking brake to cool down. Repeat steps (1) through (3) again.
- (5) After breaking-in, re-adjust the parking brakes.

Parking Brake Assembly (Rear Disc Brake)

Brought to you by Eris Studios
NOT FOR RESALE

PARKING BRAKE

C: INSPECTION

1) Measure the brake disc rotor inside diameter. If the disc is scored or worn, replace the brake disc rotor.

Disc rotor inside diameter:

Standard:

190 mm (7.48 in)

Service limit:

191 mm (7.52 in)

2) Measure the lining thickness. If it exceeds the limit, replace the brake shoes.

Lining thickness:

Standard:

2.8 mm (0.11 in)

Service limit:

1.5 mm (0.059 in)

NOTE:

Replace the right and left brake shoe as a set.

D: ADJUSTMENT

1. SHOE CLEARANCE

- 1) Return the parking brake lever fully.
- 2) Remove the adjusting hole cover from the disc rotor.
- 3) Turn the adjusting screw using a flat tip screwdriver until the brake shoe is in close contact with the disc rotor.

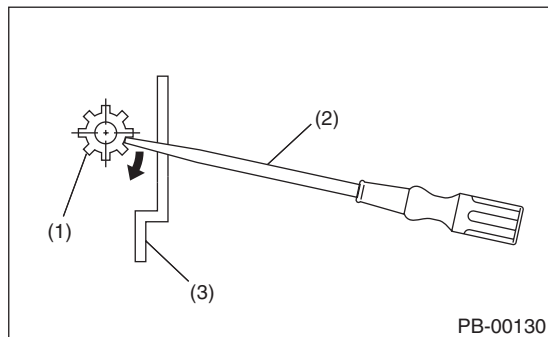

- (1) Adjusting screw
- (2) Flat tip screwdriver
- (3) Disc rotor

4) Turn back (upward) the adjusting screw 3 to 4 notches.

CAUTION:

Check there is no brake drag.

- 5) Install the adjusting hole cover to the disc rotor.
- 6) Adjust the parking lever stroke. <Ref. to PB-8, LEVER STROKE, ADJUSTMENT, Parking Brake Assembly (Rear Disc Brake).>

2. LEVER STROKE

- 1) Adjust the shoe clearance before adjusting lever stroke. <Ref. to PB-8, SHOE CLEARANCE, ADJUSTMENT, Parking Brake Assembly (Rear Disc Brake).>
- 2) Remove the parking lever cover.
- 3) Pull the parking brake lever hard 3 to 5 times.
- 4) Turn the adjusting nut until the lever stroke is at the specified value.

Lever stroke:

7 to 8 notches when pulled with a force of 200 N (20.4 kgf, 45 lbf)

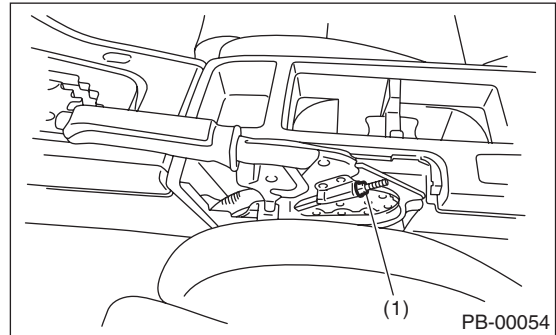

- (1) Adjusting nut (Self-locking nut)

- 5) Check there is no brake drag.
- 6) Install the parking lever cover.

5. General Diagnostic Table

A: INSPECTION

Symptom	Possible cause	Corrective action
Brake drag	Parking brake lever not adjusted correctly.	Adjust.
	Parking brake cable does not move.	Correct or replace.
	Parking brake shoe clearance is maladjusted.	Adjust.
	Return spring is faulty.	Replace.
Noise from brake	Return spring is faulty.	Replace.
	Shoe hold-down spring faulty.	Replace.

General Diagnostic Table

PARKING BRAKE

Brought to you by Eris Studios
NOT FOR RESALE