

Brought to you by Eris Studios
NOT FOR RESALE

REAR SUSPENSION

1. General Description

A: SPECIFICATION

Refer to "FS" section for rear suspension specifications. <Ref. to FS-2, SPECIFICATION, General Description.>

NOTE:

- Front and rear toe-in and front camber can be adjusted. Adjust if the toe-in or camber tolerance exceeds specifications.
- Other items indicated in the specifications table cannot be adjusted. If other items exceed specifications, check the suspension parts and connections for deformation. If defective, replace with new parts.

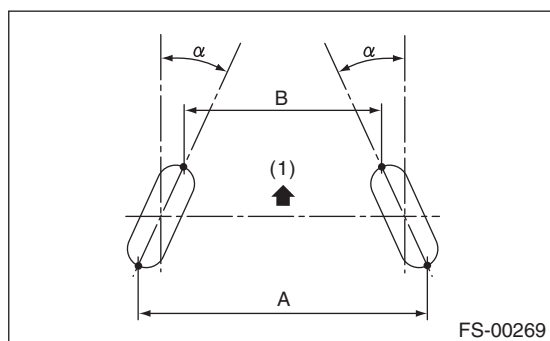

(1) Front

A – B = Positive: Toe-in, Negative: Toe-out

α = Individual toe angles

Brought to you by **3D-Modelling Studios**
 NOT FOR SALE

B: COMPONENT

1. REAR SUSPENSION

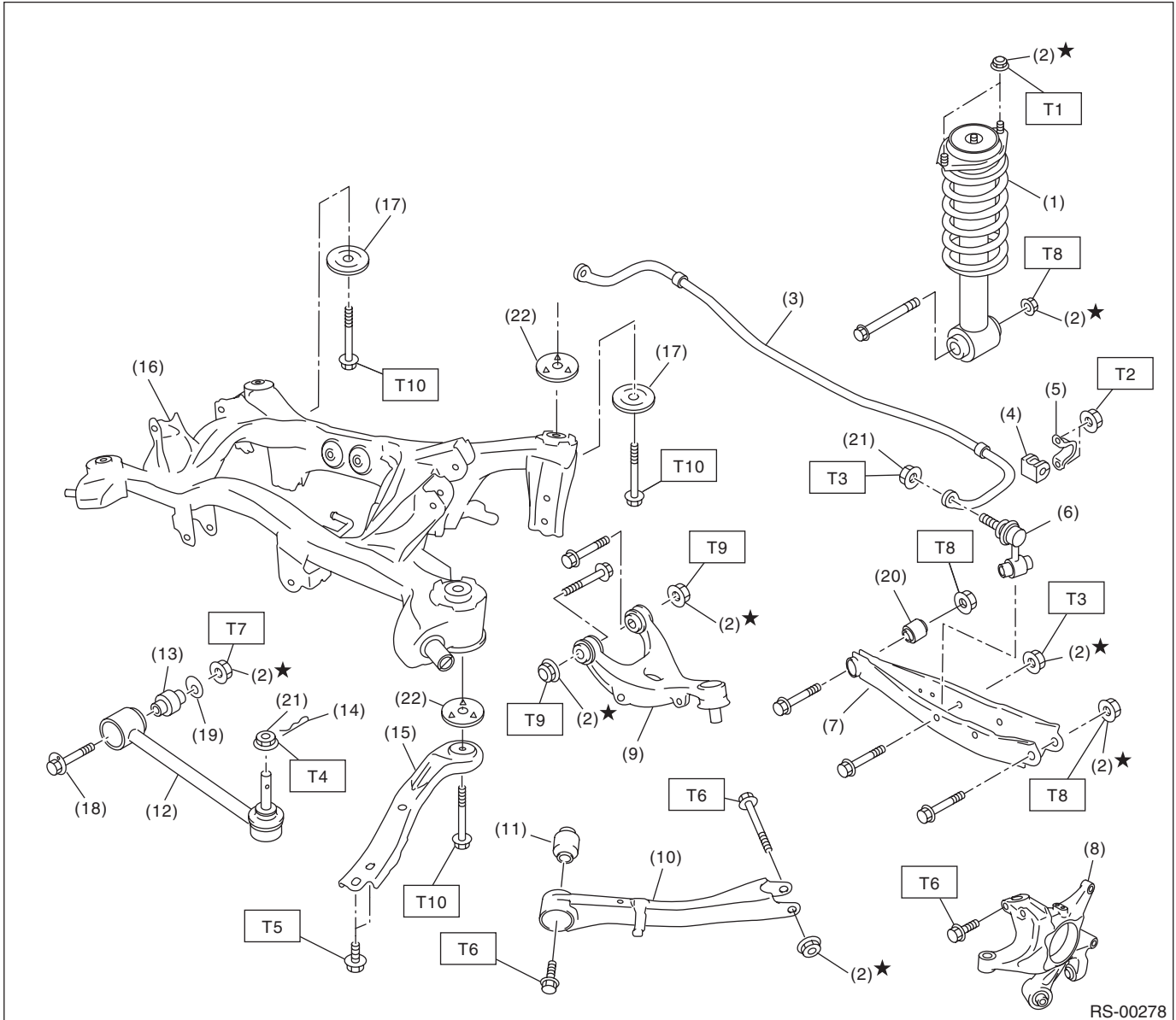

RS-00278

- | | |
|----------------------------|---|
| (1) Shock absorber | (13) Front lateral link bushing |
| (2) Self-locking nut | (14) Snap pin |
| (3) Rear stabilizer | (15) Front sub frame support plate |
| (4) Stabilizer bushing | (16) Rear sub frame |
| (5) Stabilizer clamp | (17) Rear sub frame stopper plate (lower) |
| (6) Stabilizer link | (18) Adjusting bolt |
| (7) Rear lateral link | (19) Adjusting washer |
| (8) Rear housing | (20) Rear lateral link bushing |
| (9) Upper arm | (21) Flange nut |
| (10) Trailing link | (22) Rear sub frame stopper plate (upper) |
| (11) Trailing link bushing | |
| (12) Front lateral link | |

Tightening torque: N·m (kgf·m, ft·lb)

- T1: 30 (3.1, 22.4)**
T2: 40 (4.1, 29.5)
T3: 45 (4.6, 33.2)
T4: 60 (6.1, 44)
T5: 70 (7.1, 51.6)
T6: 90 (9.2, 66.4)
T7: 100 (10.2, 73.8)
T8: 120 (12.2, 89)
T9: 150 (15.3, 111)
T10: 200 (20.4, 148)

General Description

Brought to you by Eris Studios
NOT FOR RESALE

REAR SUSPENSION

2. SHOCK ABSORBER

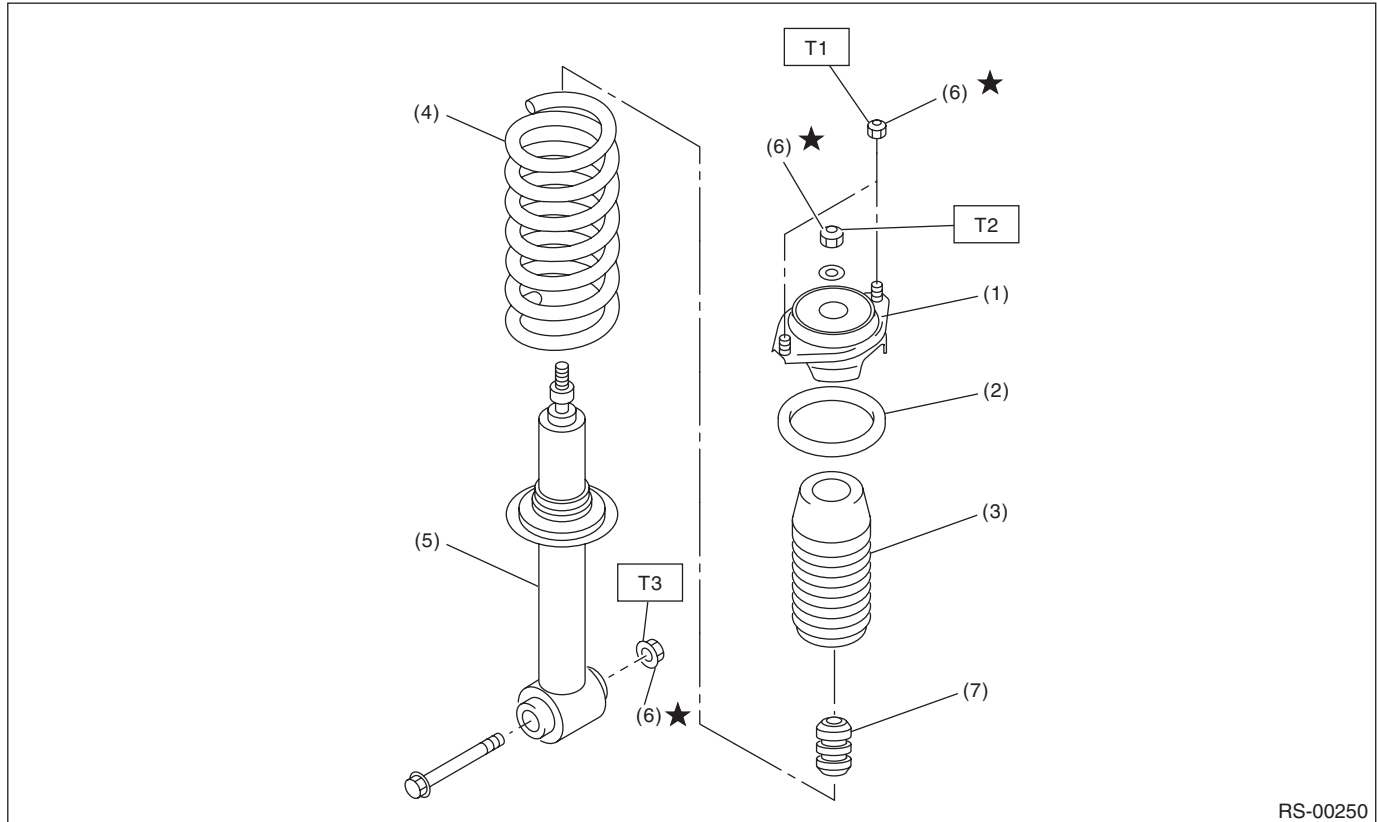

- | | |
|------------------------|----------------------|
| (1) Mount | (5) Shock absorber |
| (2) Upper rubber sheet | (6) Self-locking nut |
| (3) Dust cover | (7) Helper |
| (4) Coil spring | |

Tightening torque:N-m (kgf-m, ft-lb)
T1: 25 (2.5, 18.4)
T2: 30 (3.1, 22.4)
T3: 120 (12.2, 88.5)

C: CAUTION

Please clearly understand and adhere to the following general precautions. They must be strictly followed to avoid minor or serious injury to the person doing the work or people in the area.

1. CAUTIONS

- Wear appropriate work clothing, including a cap, protective goggles and protective shoes when performing any work.
- Before disposing of shock absorbers, be sure to bleed the gas out completely. Also, do not expose to flames or fire.
- Before removal, installation or disassembly, be sure to clarify the failure. Avoid unnecessary removal, installation, disassembly and replacement.
- Use SUBARU genuine grease etc. or equivalent. Do not mix grease etc. of different grades or manufacturers.
- Before securing a part on a vise, place cushioning material such as wood blocks, aluminum plate, or cloth between the part and the vise.
- Be sure to tighten fasteners including bolts and nuts to the specified torque.
- Place shop jacks or rigid racks at the specified points.

2. OIL

When handling oil, carefully observe the following to prevent unexpected accidents.

- Prepare container and waste cloths when performing work which oil could possibly spill. If oil spills, wipe it off immediately to prevent from penetrating into floor or flowing outside, for environmental protection.
- Follow all government regulations concerning disposal of refuse when disposing.

D: PREPARATION TOOL

1. SPECIAL TOOL

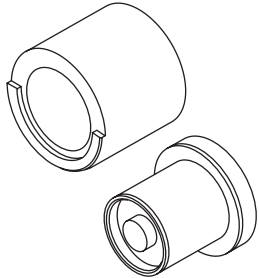
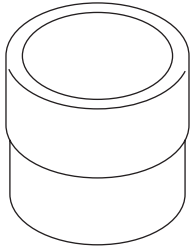
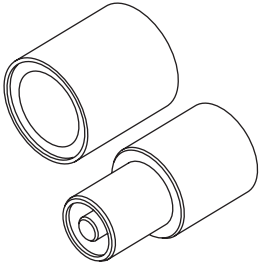
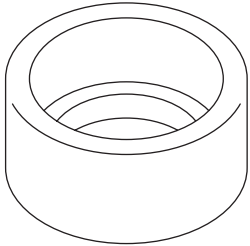
ILLUSTRATION	TOOL NUMBER	TOOL NAME	REMARKS
 <p style="text-align: center;">ST20099AE000</p>	20099AE000	INSTALLER & REMOVER	Used for replacing the front lateral link bushing.
 <p style="text-align: center;">ST-499755602</p>	499755602	PRESS	Used for replacing the rear trailing link bushing.
 <p style="text-align: center;">ST20099AE010</p>	20099AE010	INSTALLER & REMOVER	Used for replacing the rear lateral link bushing.
 <p style="text-align: center;">ST20299AG010</p>	20299AG010	BASE	Used for replacing the rear trailing link bushing.

General Description

Brought to you by Eris Studios
NOT FOR RESALE

REAR SUSPENSION

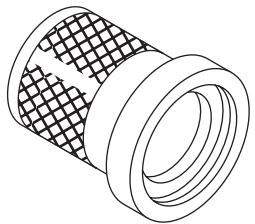
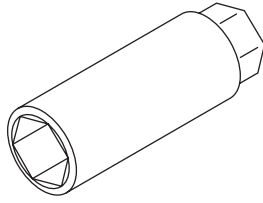
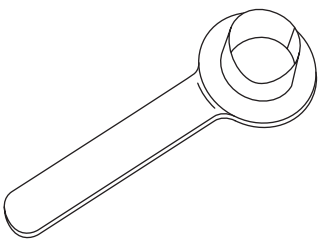
ILLUSTRATION	TOOL NUMBER	TOOL NAME	REMARKS
 ST-899874100	899874100	INSTALLER	Used for replacing the rear trailing link bushing.
 ST20399FG000	20399FG000	STRUT MOUNT SOCKET	<ul style="list-style-type: none"> • Used for removing and installing shock mount. • Used for checking torque of shock mount center nut.
 ST28099PA090	28099PA090	OIL SEAL PROTECTOR	<ul style="list-style-type: none"> • Used for installing the rear drive shaft to the rear differential. • For oil seal protection

2. GENERAL TOOL

TOOL NAME	REMARKS
Alignment tester	Used for measuring wheel alignment.
Toe-in gauge	Used for toe-in measurement.
Jack	Used for removing and installing suspension.
Bearing puller	Used for removing bushings.
Coil spring compressor	Used for disassembling and assembling shock absorber.

2. Wheel Alignment

A: INSPECTION

NOTE:

Measure and adjust the front and rear wheel alignment at a time. Refer to "FS" section for measurement and adjustment of wheel alignment. <Ref. to FS-6, INSPECTION, Wheel Alignment.>

REAR SUSPENSION

3. Rear Stabilizer

A: REMOVAL

- 1) Lift up the vehicle, and then remove the rear wheels.
- 2) Remove the stabilizer link.

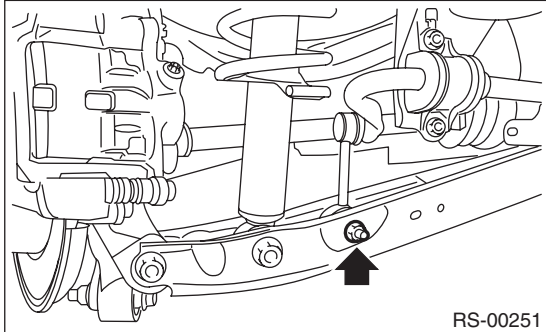

- 3) Remove the stabilizer clamp.

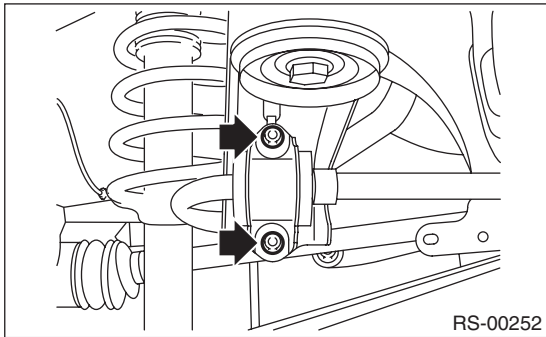

B: INSTALLATION

NOTE:

- Be sure to use a new flange nut and self-locking nut.
- Always tighten the stabilizer bushing in the state where the vehicle is at curb weight and the wheels are in full contact with the ground.
- Align the paint mark end of stabilizer to the end of stabilizer bushing when installing.

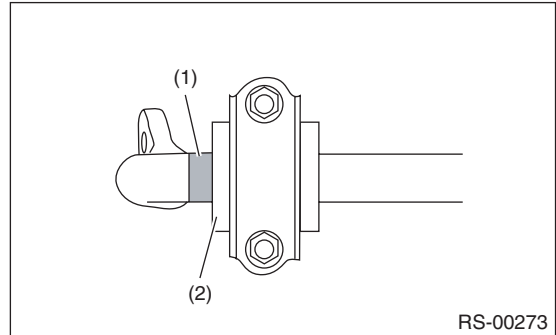

- (1) Identification paint
- (2) Bushing

Install in the reverse order of removal.

Tightening torque:

Stabilizer link

45 N·m (4.6 kgf-m, 33.2 ft-lb)

Stabilizer clamp

40 N·m (4.1 kgf-m, 29.5 ft-lb)

C: INSPECTION

- 1) Check the bushing for abnormal cracks, fatigue or damage.
- 2) Check the stabilizer link for damage.

4. Rear Trailing Link

A: REMOVAL

- 1) Lift up the vehicle, and then remove the rear wheels.
- 2) Remove the bracket, and remove the parking brake cable from the guide.

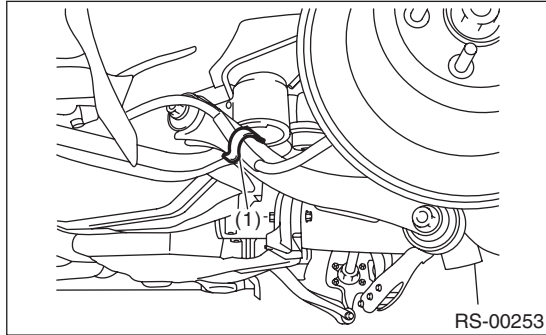

(1) Guide

- 3) Remove the trailing link.

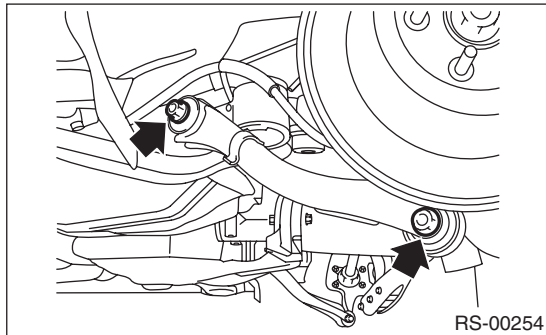

B: INSTALLATION

NOTE:

- Be sure to use a new self-locking nut.
- Always tighten the bushing in the state where the vehicle is at curb weight and the wheels are in full contact with the ground.

Install in the reverse order of removal.

Tightening torque:

90 N·m (9.2 kgf·m, 66.4 ft·lb)

C: DISASSEMBLY

Using the ST A and ST B, press the bushing out.

STA 8998741000 INSTALLER

STB 499755602 PRESS

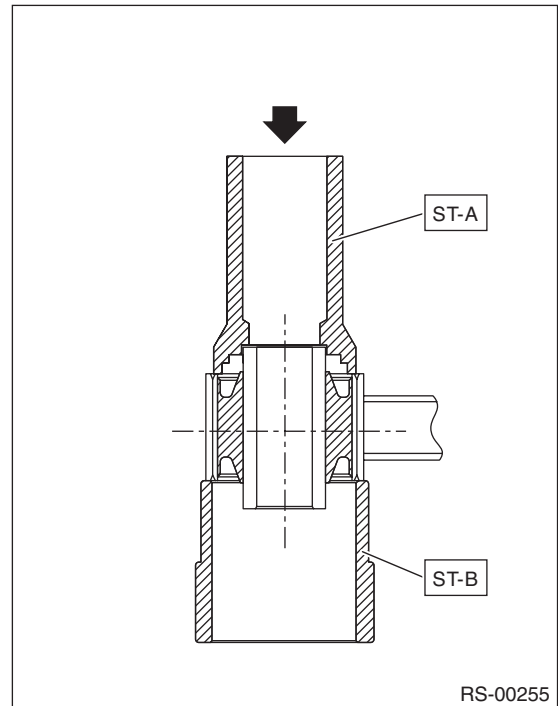

D: ASSEMBLY

Using the ST A and ST B, press-fit the bushing.

STA 8998741000 INSTALLER

STB 20299AG010 BASE

CAUTION:

Make sure to press the bushing straight in.

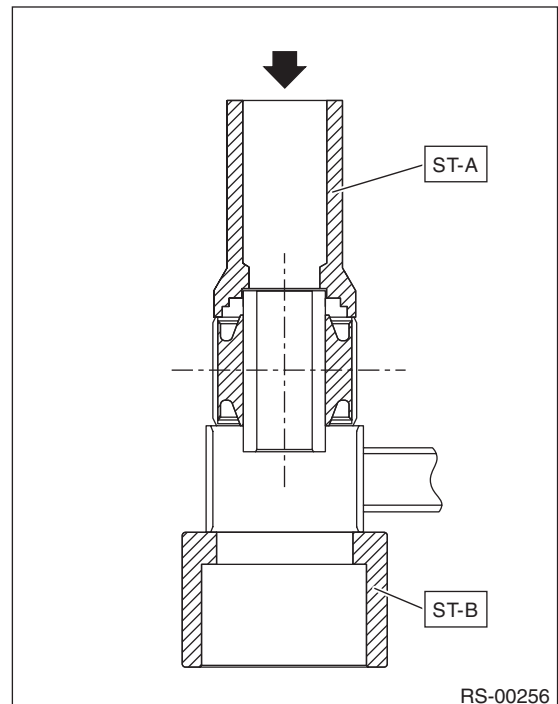

Rear Trailing Link

REAR SUSPENSION

E: INSPECTION

Visually check the trailing link for damage and deformation.

Brought to you by Eris Studios
NOT FOR RESALE

5. Upper Arm

A: REMOVAL

- 1) Remove the rear sub frame. <Ref. to RS-15, REMOVAL, Rear Sub Frame.>
- 2) Remove the rear ABS wheel speed sensor bracket.

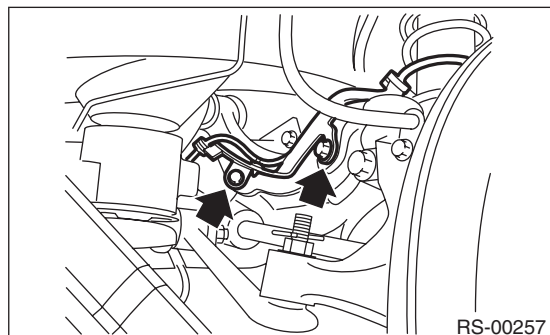

- 3) Remove the bolts, then remove the upper arm.

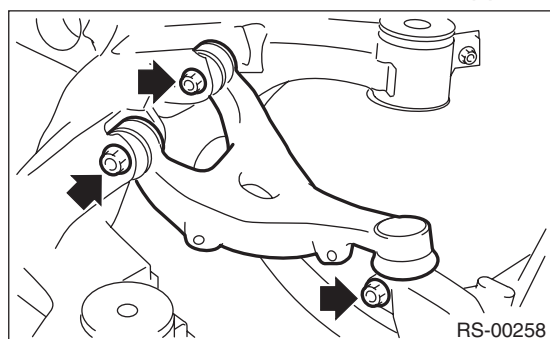

B: INSTALLATION

NOTE:

- Use a new self-locking nut.
- Always tighten the bushing when the arm is positioned in the state where the vehicle is at curb weight and the wheels are in full contact with the ground.

- 1) Install in the reverse order of removal.
- 2) Inspect the wheel alignment and adjust if necessary.

Tightening torque:

Upper arm — Rear sub frame

150 N·m (15.3 kgf·m, 111 ft·lb)

Upper arm — Rear housing

90 N·m (9.2 kgf·m, 66.4 ft·lb)

Rear ABS wheel speed sensor bracket

7.5 N·m (0.76 kgf·m, 5.5 ft·lb)

C: INSPECTION

- 1) Visually check the upper arm for damage and deformation.
- 2) Visually check the bushing for abnormal cracks, fatigue or damage.

6. Rear Shock Absorber

A: REMOVAL

- 1) Remove the luggage floor mat. (Wagon model)
- 2) Remove the trunk room mat. (Sedan model)
- 3) Remove the strut cap of the quarter trim.
- 4) Lift up the vehicle, and then remove the rear wheels.
- 5) Remove the nut and disconnect the rear stabilizer link.
- 6) Remove the shock absorber lower bolt.
- 7) Disconnect the rear lateral link.

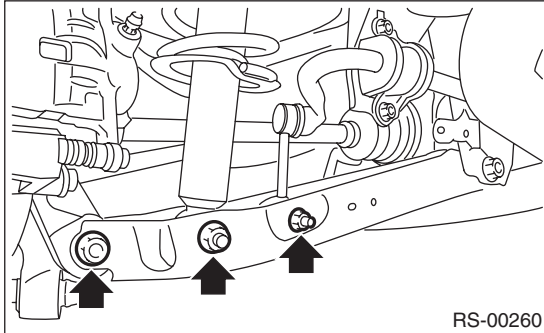

- 8) Remove the shock absorber mount nut.

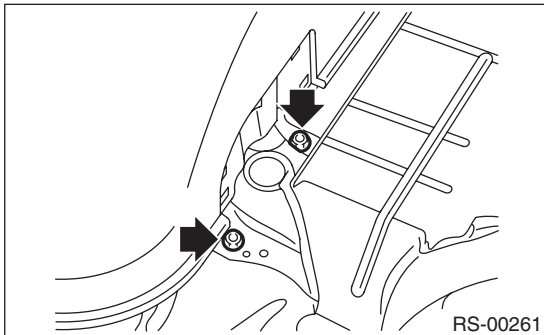

- 9) Remove the shock absorber.

B: INSTALLATION

NOTE:

- Be sure to use a new self-locking nut.
- Always tighten the bushing in the state where the vehicle is at curb weight and the wheels are in full contact with the ground.

- 1) Install in the reverse order of removal.

Tightening torque:

Refer to “COMPONENT” of “General Description” for the tightening torque. <Ref. to RS-3, COMPONENT, General Description.>

- 2) Check the wheel alignment and adjust it if necessary.

C: DISASSEMBLY

Refer to “Front Strut” for disassembly procedure. <Ref. to FS-22, DISASSEMBLY, Front Strut.>

D: ASSEMBLY

Refer to “Front Strut” for installation procedures. <Ref. to FS-22, ASSEMBLY, Front Strut.>

E: INSPECTION

Refer to “Front Strut” for inspection procedures. <Ref. to FS-23, INSPECTION, Front Strut.>

F: DISPOSAL

CAUTION:

- Before handling the shock absorber, be sure to wear goggles to protect eyes from gas, oil and cutting powder.
- Do not disassemble the shock absorber or place it into a fire.
- Drill a hole into shock absorbers in case of discarding shock absorbers filled with gas.

- 1) Place the shock absorber on a level surface with the piston rod fully expanded.
- 2) Make a hole into the specified position 30 mm (1.18 in) deep using a drill with 2 — 3 mm (0.08 — 0.12 in) diameter.

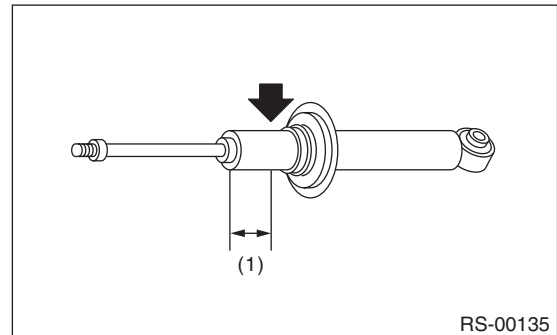

(1) 40 mm (1.57 in)

7. Front Lateral Link

A: REMOVAL

- 1) Lift up the vehicle, and then remove the rear wheels.
- 2) Remove the rear trailing link. <Ref. to RS-9, REMOVAL, Rear Trailing Link.>
- 3) Remove the snap pin and nut.

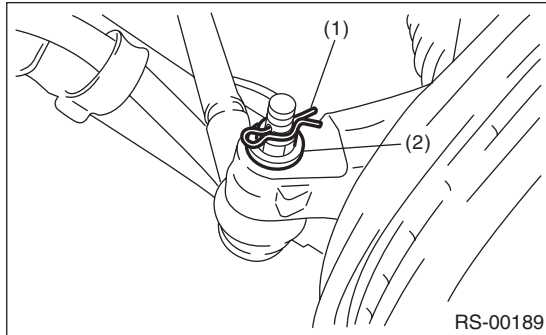

- (1) Snap pin
- (2) Nut

- 4) Using a puller, remove the ball joint.

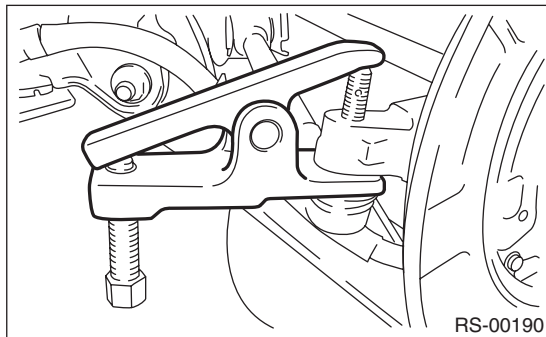

- 5) Scribe an alignment mark on the front lateral link adjusting bolt and rear sub frame.
- 6) Remove the adjusting bolt, and remove the front lateral link.

CAUTION:

When removing the adjusting bolt, make sure to fix the bolt head in place when loosening the nut.

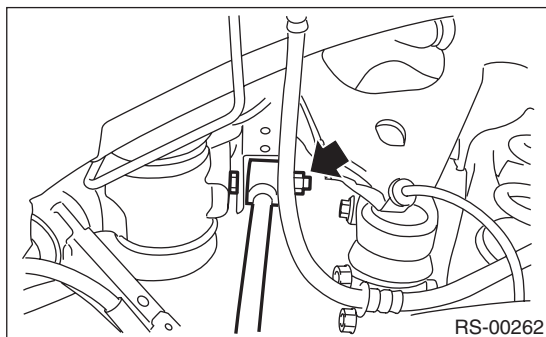

B: INSTALLATION

NOTE:

- Be sure to use a new self-locking nut.
- Always tighten the bushing in the state where the vehicle is at curb weight and the wheels are in full contact with the ground.

- 1) Install in the reverse order of removal.

Tightening torque:

Front lateral link — Sub frame

100 N·m (10.2 kgf-m, 73.8 ft-lb)

Front lateral link — Rear axle housing

60 N·m (6.1 kgf-m, 44 ft-lb)

- 2) Inspect the wheel alignment and adjust if necessary.

C: INSPECTION

Visually check the front lateral link for damage and deformation.

D: DISASSEMBLY

Using the ST A and ST B, press the bushing out.
 STA 20099AE000 INSTALLER & REMOVER
 STB 20099AE000 INSTALLER & REMOVER

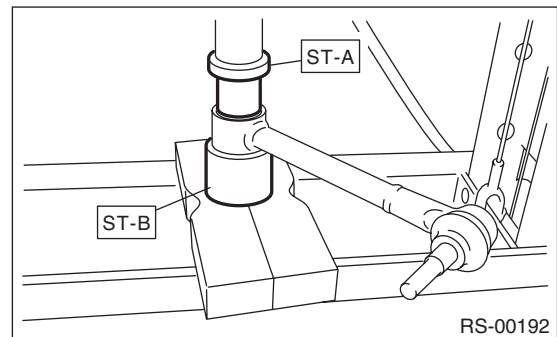

E: ASSEMBLY

Using the ST A and ST B, press-fit the bushing.
 STA 20099AE000 INSTALLER & REMOVER
 STB 20099AE000 INSTALLER & REMOVER

CAUTION:

Make sure to press the bushing straight in.

REAR SUSPENSION

8. Rear Lateral Link

A: REMOVAL

- 1) Lift up the vehicle, and then remove the rear wheels.
- 2) Remove the nut and disconnect the stabilizer link.
- 3) Remove the shock absorber lower bolt.
- 4) Remove the bolt, and remove rear lateral link.

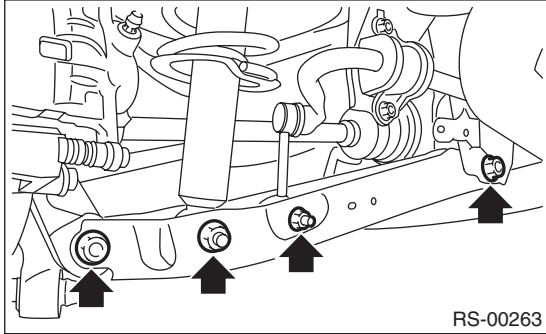

B: INSTALLATION

NOTE:

- Be sure to use a new self-locking nut.
- Always tighten the bushing in the state where the vehicle is at curb weight and the wheels are in full contact with the ground.

- 1) Install in the reverse order of removal.

Tightening torque:

Rear lateral link

120 N·m (12.2 kgf·m, 89 ft·lb)

Shock absorber

120 N·m (12.2 kgf·m, 89 ft·lb)

Stabilizer link

45 N·m (4.6 kgf·m, 33.2 ft·lb)

- 2) Inspect the wheel alignment and adjust if necessary.

C: DISASSEMBLY

Using the ST A and ST B, press the bushing out.

STA 20099AE010 INSTALLER & REMOVER

STB 20099AE010 INSTALLER & REMOVER

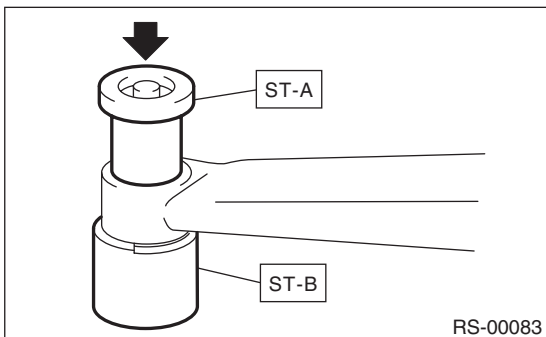

D: ASSEMBLY

Using the ST A and ST B, press-fit the bushing.

STA 20099AE010 INSTALLER & REMOVER

STB 20099AE010 INSTALLER & REMOVER

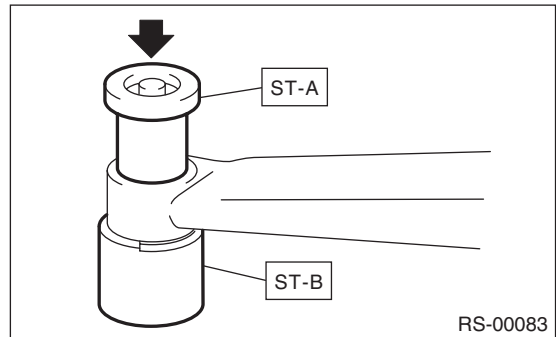

E: INSPECTION

Visually check the rear lateral link for damage and deformation.

Brought to you by *Chris Studios*
 NOT FOR SALE

9. Rear Sub Frame

A: REMOVAL

- 1) Separate the front exhaust pipe and rear exhaust pipe.
- 2) Remove the rear exhaust pipe and muffler.
- 3) Remove the propeller shaft.
 <Ref. to DS-10, REMOVAL, Propeller Shaft.>
- 4) Remove the brake hose bracket.

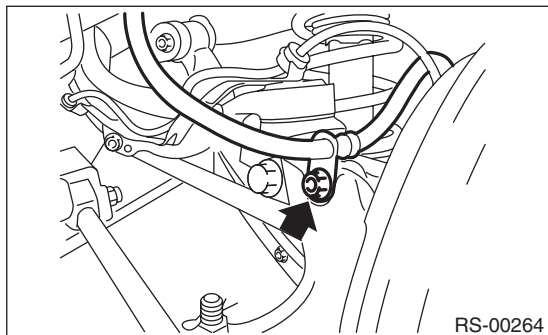

- 5) Remove the rear disc brake caliper and suspend it from the shock absorber (disc brake model).

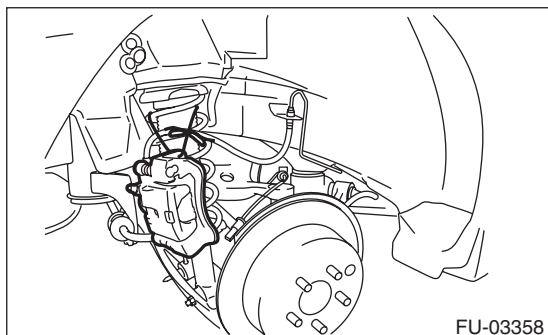

- 6) Remove the rear parking brake cable from the parking brake assembly. <Ref. to PB-6, REMOVAL, Parking Brake Assembly (Rear Disc Brake).>
- 7) Remove the rear hub unit bearing and suspend the rear brake from the shock absorber (Drum brake model). <Ref. to DS-22, REMOVAL, Rear Hub Unit Bearing.>

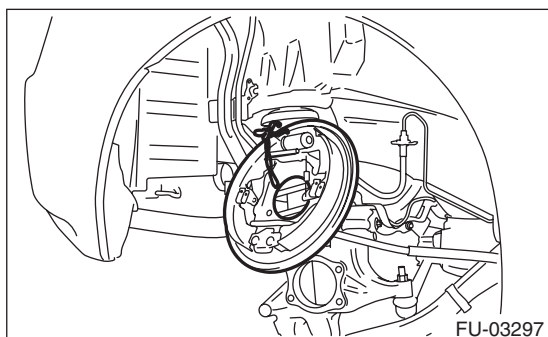

- 8) Disconnect the ABS wheel speed sensor connector.

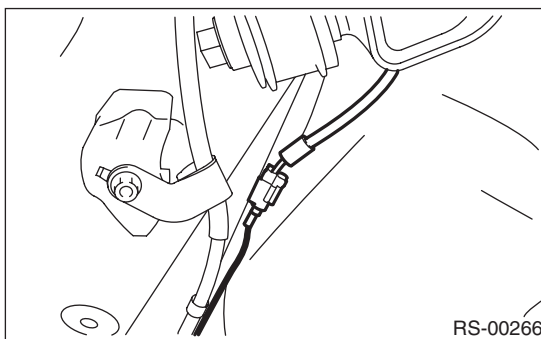

- 9) Disconnect the drain hose (B) from canister drain connector (A).

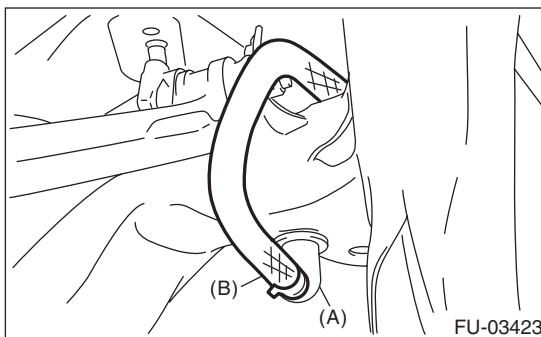

- 10) Remove the shock absorber lower bolt.

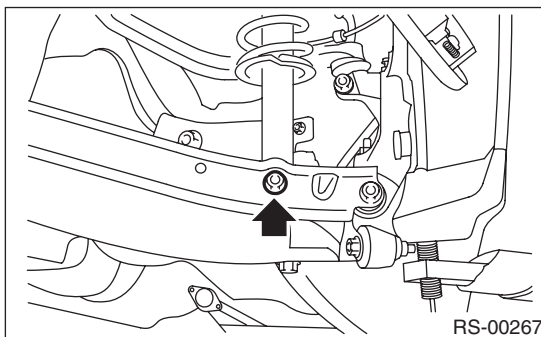

- 11) Support the sub frame using a jack.
- 12) Remove the support plate.

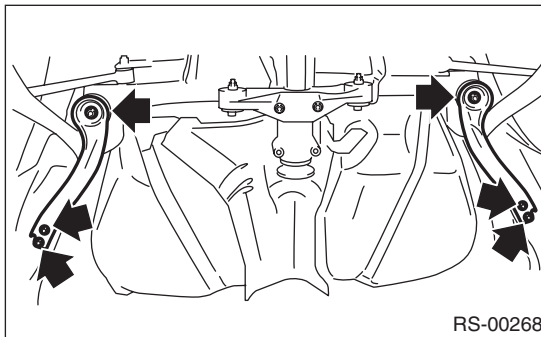

REAR SUSPENSION

13) Remove the rear sub frame.

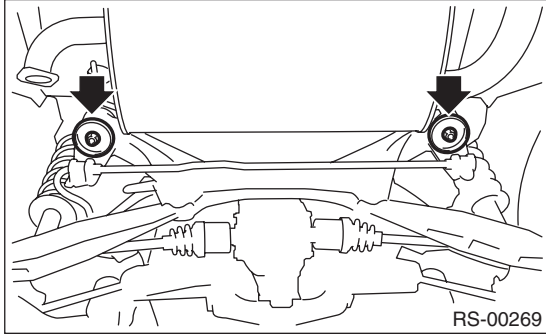

B: INSTALLATION

NOTE:

- Be sure to use a new self-locking nut.
- Always tighten the bushing in the state where the vehicle is at curb weight and the wheels are in full contact with the ground.

1) Install in the reverse order of removal.

Tightening torque:

Refer to “COMPONENT” of “General Description” for the tightening torque. <Ref. to RS-3, COMPONENT, General Description.>

- 2) Bleed air from brake system.
- 3) Inspect the wheel alignment and adjust if necessary.

C: INSPECTION

Check the removed parts for wear, damage and crack, and repair or replace them if faulty.

10. General Diagnostic Table

A: INSPECTION

1. IMPROPER VEHICLE POSTURE OR IMPROPER WHEEL ARCH HEIGHT

Possible cause	Corrective action
(1) Permanent distortion or damaged coil spring	Replace.
(2) Rough operation of damper strut or shock absorber	Replace.
(3) Improper installation of strut or shock absorber	Replace with proper parts.
(4) Installation of the wrong coil spring	Replace with proper parts.

2. POOR RIDE COMFORT

- 1) Large rebound shock
- 2) Rocking of the vehicle continues too long after running over bump and hump.
- 3) Excessive shock in bumping

Possible cause	Corrective action
(1) Damaged coil spring	Replace.
(2) Overinflation of tires	Adjust.
(3) Improper wheel arch height	Adjust or replace the coil springs with new parts.
(4) Fault in operation of damper strut or shock absorber	Replace.
(5) Damage or deformation of strut mount or shock absorber mount	Replace.
(6) Unsuitable length (maximum or minimum) of damper strut or shock absorber	Replace with appropriate parts.
(7) Deformation or loss of bushing	Replace.
(8) Deformation or damage of helper in strut assembly or shock absorber	Replace.
(9) Oil leakage from the damper strut or shock absorber	Replace.

3. NOISE

Possible cause	Corrective action
(1) Wear or damage of damper strut or shock absorber component parts	Replace.
(2) Loosening of the suspension link installing bolt	Tighten to the specified torque.
(3) Deformation or loss of bushing	Replace.
(4) Unsuitable length (maximum or minimum) of damper strut or shock absorber	Replace with appropriate parts.
(5) Damaged coil spring	Replace.
(6) Wear or damage of the ball joint	Replace.
(7) Deformation of the stabilizer clamp	Replace.

General Diagnostic Table

REAR SUSPENSION

Brought to you by Eris Studios
NOT FOR RESALE