

Brought to you by Eris Studios
NOT FOR RESALE

VEHICLE DYNAMICS CONTROL (VDC)

General Description

VEHICLE DYNAMICS CONTROL (VDC)

Brought to you by Eris Studios
NOT FOR RESALE

1. General Description

A: SPECIFICATION

Item			Specification or identification	
ABS wheel speed sensor	ABS wheel speed sensor gap (for reference)	Front	0.77 — 1.43 mm (0.030 — 0.056 in)	
		Rear	0.64 — 1.56 mm (0.025 — 0.061 in)	
	Identifications of harness (marks, color)	Front	RH	K1 (White)
			LH	K2 (Yellow)
		Rear	RH	P1 (Pink)
			LH	P2 (Blue)
VDCCM&H/U Identification	AT	S1		
	MT	S2		

B: COMPONENT

1. ABS WHEEL SPEED SENSOR

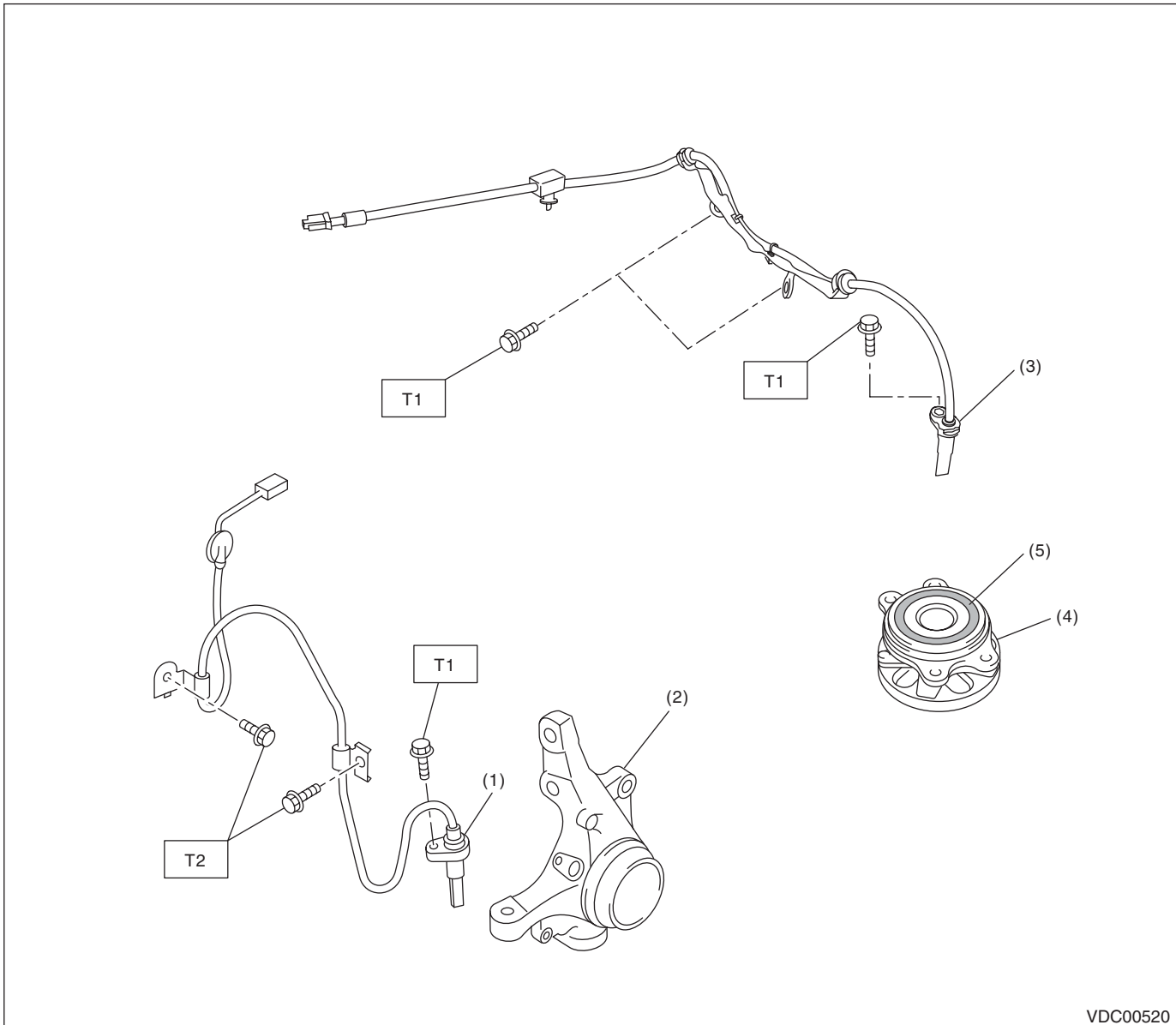

- | | |
|----------------------------------|----------------------|
| (1) Front ABS wheel speed sensor | (4) Hub unit bearing |
| (2) Front housing | (5) Magnetic encoder |
| (3) Rear ABS wheel speed sensor | |

Tightening torque: N·m (kgf·m, ft·lb)

T1: 7.5 (0.76, 5.5)

T2: 33 (3.4, 24.3)

General Description

VEHICLE DYNAMICS CONTROL (VDC)

Brought to you by Eris Studios
NOT FOR RESALE

2. YAW RATE & LATERAL G SENSOR

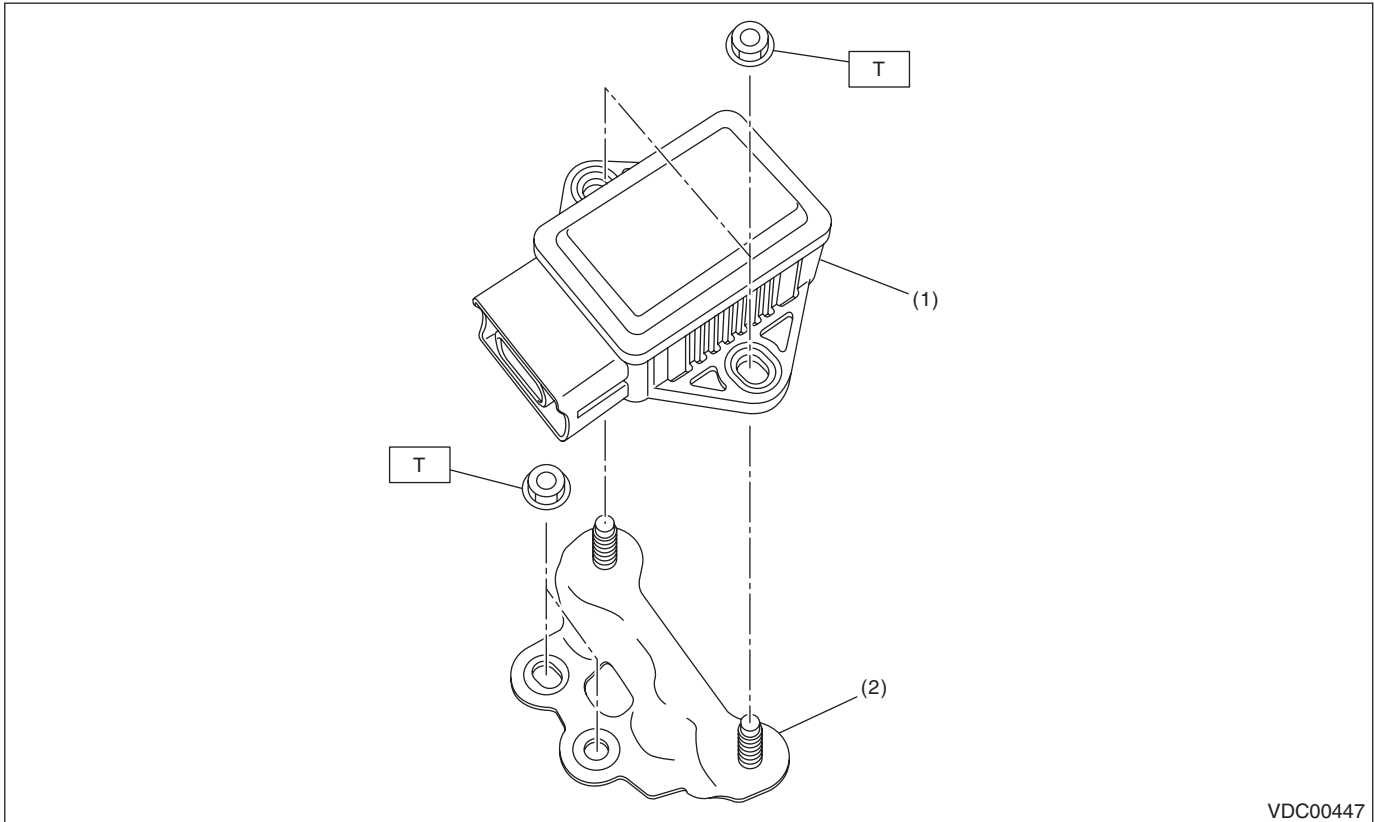

VDC00447

- (1) Yaw rate & lateral G sensor (2) Bracket

Tightening torque: N-m (kgf-m, ft-lb)
T: 7.5 (0.76, 5.5)

3. STEERING ANGLE SENSOR

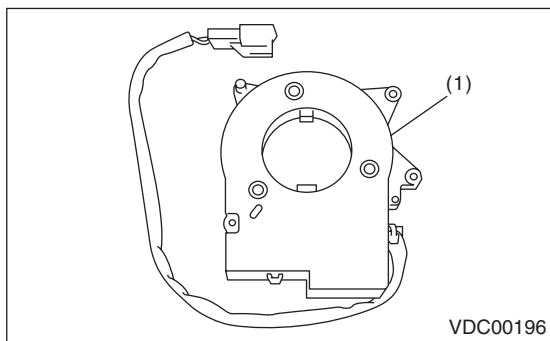

- (1) Steering angle sensor

4. VDC CONTROL MODULE & HYDRAULIC CONTROL UNIT (VDCCM&H/U)

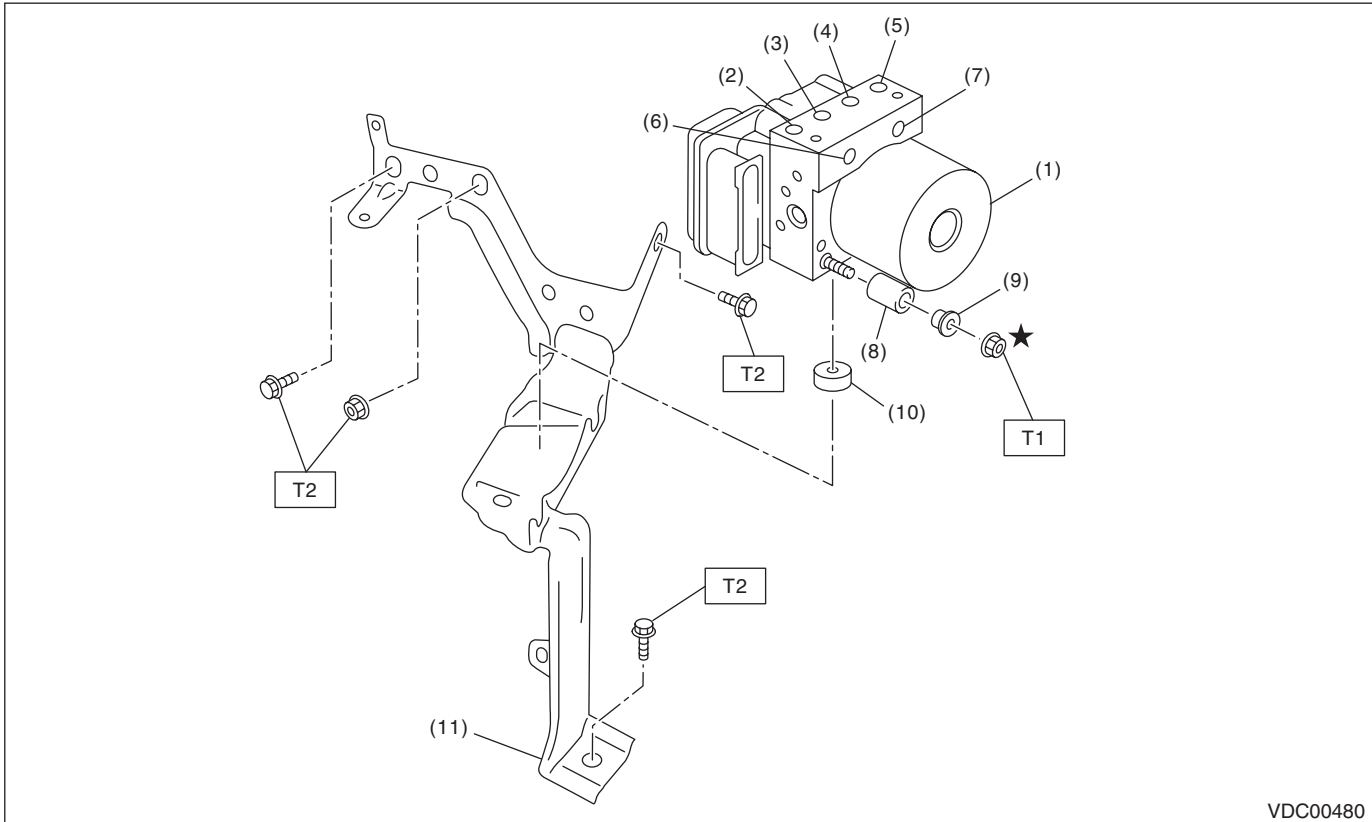

VDC00480

- | | | |
|---|---------------------|--------------|
| (1) VDC control module & hydraulic control unit (VDCCM&H/U) | (6) Primary inlet | (11) Bracket |
| (2) Front RH outlet | (7) Secondary inlet | |
| (3) Rear LH outlet | (8) Damper | |
| (4) Rear RH outlet | (9) Spacer | |
| (5) Front LH outlet | (10) Damper | |

Tightening torque: N·m (kgf·m, ft·lb)

T1: 7.5 (0.76, 5.5)

T2: 33 (3.4, 24.3)

C: CAUTION

- Wear appropriate work clothing, including a cap, protective goggles and protective shoes when performing any work.
- Remove contamination including dirt and corrosion before removal, installation or disassembly.
- Keep the disassembled parts in order and protect them from dust and dirt.
- Before disconnecting connectors of sensors or units, be sure to disconnect the ground cable from the battery.
- Before removal, installation or disassembly, be sure to clarify the failure. Avoid unnecessary removal, installation, disassembly and replacement.
- Vehicle components are extremely hot after driving. Be wary of receiving burns from heated parts.
- Be sure to tighten fasteners including bolts and nuts to the specified torque.
- Place shop jacks or rigid racks at the specified points.

General Description

VEHICLE DYNAMICS CONTROL (VDC)

Brought to you by Eris Studios
NOT FOR RESALE

D: PREPARATION TOOL

1. SPECIAL TOOL

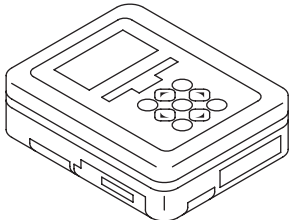
ILLUSTRATION	TOOL NUMBER	DESCRIPTION	REMARKS
 ST1B021XU0	1B021XU0	SUBARU SELECT MONITOR III KIT	Used for troubleshooting for electrical system.

2. GENERAL TOOL

TOOL NAME	REMARKS
Circuit tester	Used for measuring resistance, voltage and current.
Pressure gauge	Used for measuring oil pressure.
Oscilloscope	Used for measuring the sensor.
TORX® bit E5	Used for replacing VDC control module.

Brought to you by Eris Studios
NOT FOR SALE

2. VDC Control Module and Hydraulic Control Unit (VDCCM&H/U)

A: REMOVAL

- 1) Disconnect the ground cable from the battery.
- 2) Use compressed air to remove moisture and dust around the VDCCM&H/U.

NOTE:

If the terminals become dirty, it may cause improper contact.

- 3) Lift the lock lever and Disconnect the VDCCM&H/U connector.

CAUTION:

Do not pull on the harness when disconnecting the connector.

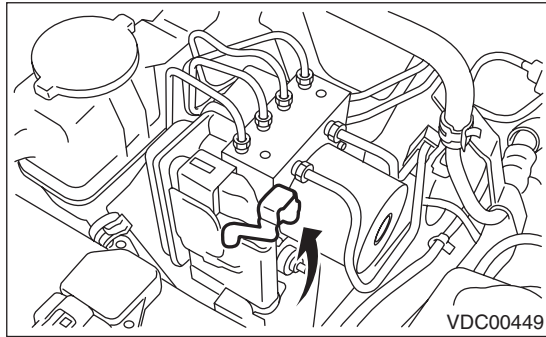

- 4) Disconnect the brake pipes from the VDCCM&H/U.
- 5) Wrap the brake pipe with a vinyl bag so as not to spill the brake fluid on the vehicle body.

CAUTION:

If brake fluid is spilled on the vehicle body, wash it off immediately with water and wipe clean.

- 6) Remove the nuts and remove the VDCCM&H/U.

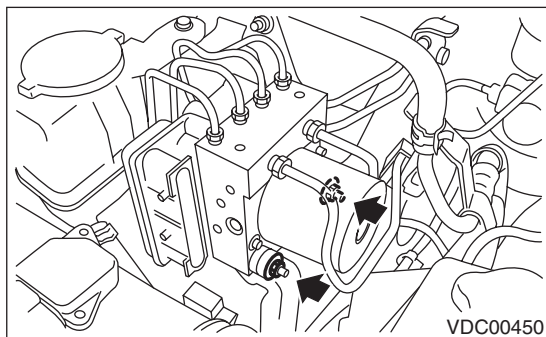

CAUTION:

- Do not drop or bump the VDCCM&H/U.
- Do not turn the VDCCM&H/U upside down or place it sideways during storage.
- Be careful not to let foreign matter enter the VDCCM&H/U.
- Be careful that no water enters the connectors.

- 7) Remove the VDCCM&H/U bracket.

B: INSTALLATION

- 1) Install the VDCCM&H/U bracket.

Tightening torque:

33 N·m (3.3 kgf·m, 24 ft·lb)

- 2) Install the VDCCM&H/U with a new nut (Part No. 023506000) by aligning the damper groove of the VDCCM&H/U to the bracket side claw.

Tightening torque:

7.5 N·m (0.76 kgf·m, 5.5 ft·lb)

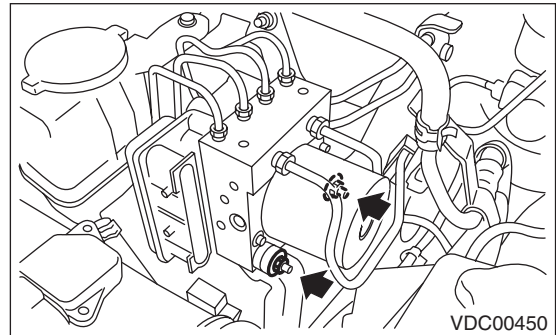

- 3) Connect the brake pipes to their correct VDC-CM&H/U positions.

Tightening torque:

T1: 15 N·m (1.5 kgf·m, 11.1 ft·lb)

T2: 19 N·m (1.9 kgf·m, 14 ft·lb)

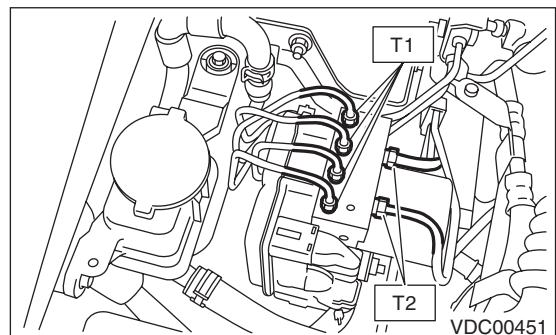

- 4) Connect the VDCCM&H/U connector.

NOTE:

- Be sure to remove all foreign matter from inside the connector before connecting.
- Make sure the VDCCM&H/U connector is securely locked.

- 5) Bleed air from the brake system.

- 6) Check the parameter to confirm that the applied models and grades of the relevant vehicle are included. <Ref. to VDC(diag)-18, PARAMETER CHECK, OPERATION, Subaru Select Monitor.>

VDC Control Module and Hydraulic Control Unit (VDCCM&H/U)

VEHICLE DYNAMICS CONTROL (VDC)

Brought to you by Eris Studios
NOT FOR RESALE

7) If the applied model and grade of the target vehicle are not included on the {Parameter Check} display screen, perform parameter selection and registration. <Ref. to VDC(diag)-18, PARAMETER SELECTION, OPERATION, Subaru Select Monitor.>

NOTE:

- When the VDCCM&H/U is replaced with a new part, be sure to perform the selection•registration operation.
- For the selection and registration of parameter, the Subaru Select Monitor is required.
- When no data is registered, ABS/EBD/VDC warning light illuminates and the DTC “Parameter selection failure” is detected.

C: INSPECTION

- 1) Check the condition of connection and settlement of connector.
- 2) Check the mark used for VDCCM&H/U identification.

Refer to “SPECIFICATION” for the identification mark. <Ref. to VDC-2, SPECIFICATION, General Description.>

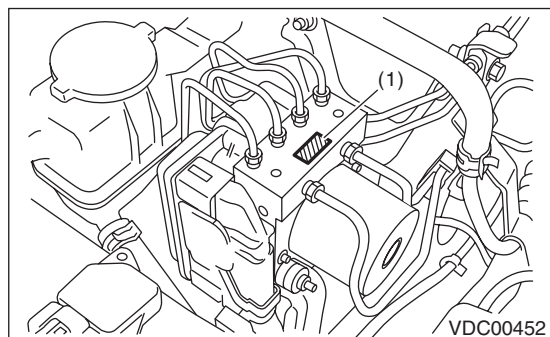

(1) Identification mark

1. CHECKING THE HYDRAULIC UNIT ABS OPERATION BY PRESSURE GAUGE

<Ref. to ABS-7, CHECKING THE HYDRAULIC UNIT ABS OPERATION BY PRESSURE GAUGE, INSPECTION, ABS Control Module and Hydraulic Control Unit (ABSCM&H/U).>

2. CHECKING THE HYDRAULIC UNIT ABS OPERATION WITH THE BRAKE TESTER

<Ref. to ABS-8, CHECKING THE HYDRAULIC UNIT ABS OPERATION WITH THE BRAKE TESTER, INSPECTION, ABS Control Module and Hydraulic Control Unit (ABSCM&H/U).>

3. CHECKING THE HYDRAULIC UNIT VDC OPERATION USING A PRESSURE GAUGE

- 1) Lift up the vehicle, and remove the wheels.
- 2) Remove the air bleeder screws from FL and FR caliper bodies.
- 3) Connect two pressure gauges to FL and FR caliper bodies.

CAUTION:

- Use a pressure gauge used exclusively for brake fluid measurement.
- Do not use a pressure gauge used for the measuring transmission oil pressure, as the piston seal may expand and deform.

NOTE:

Wrap sealing tape around the pressure gauge.

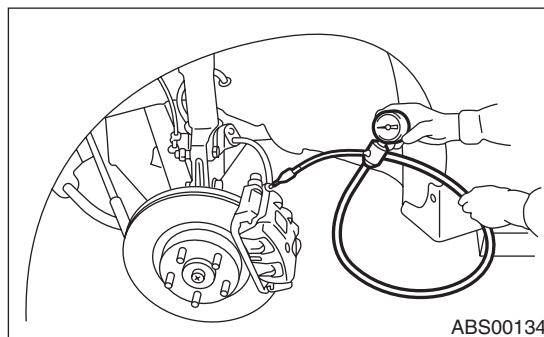

- 4) Bleed air from the pressure gauge.
- 5) Perform VDC sequence control. <Ref. to VDC-13, VDC Sequence Control.>
- 6) When the hydraulic unit begins to work, first the FL side performs compression, hold, and decompression, and then the FR side performs compression, hold, and decompression.
- 7) Read values indicated on the pressure gauge and check if the fluctuation of the values between decompression and compression meets specification. Depress the brake pedal and check that it is not abnormally hard, and tightness is normal.

	Front wheel	Rear wheel
When pressurized	3,000 kPa (31 kgf/cm ² , 441 psi) or more	3,000 kPa (31 kgf/cm ² , 441 psi) or more
When depressurized	500 kPa (5 kgf/cm ² , 73 psi) or less	500 kPa (5 kgf/cm ² , 73 psi) or less

- 8) Disconnect the pressure gauges from FL and FR caliper bodies.
- 9) Install the air bleeder screws of FL and FR caliper bodies.
- 10) Remove the air bleeder screws from RL and RR caliper bodies.
- 11) Connect two pressure gauges to RL and RR caliper bodies.

Brought to you by Eris Studios
NOT FOR RESALE

12) Bleed air from RL and RR caliper bodies, and pressure gauge.

13) Perform VDC sequence control.

<Ref. to VDC-13, VDC Sequence Control.>

14) When the hydraulic unit begins to work, first the RR side performs compression, hold, and decompression, and then the RL side performs compression, hold, and decompression.

15) Read the values indicated on the pressure gauges and check if it is within specification. Depress the brake pedal and check that it is not abnormally hard, and tightness is normal.

16) Disconnect the pressure gauge from the RL and RR caliper bodies.

17) Install the air bleeder screws of RL and RR caliper bodies.

18) Bleed air from the brake line.

4. CHECK HYDRAULIC UNIT VDC OPERATION WITH BRAKE TESTER

1) Set wheels other than the one to measure free rollers.

2) Prepare to operate the VDC sequence control.

<Ref. to VDC-13, VDC Sequence Control.>

3) Set the front wheels or rear wheels on the brake tester and set the select lever position to the "N" range.

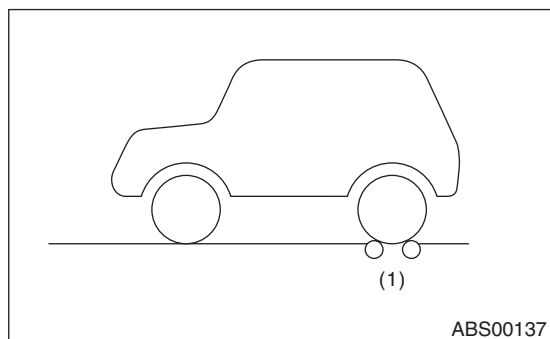
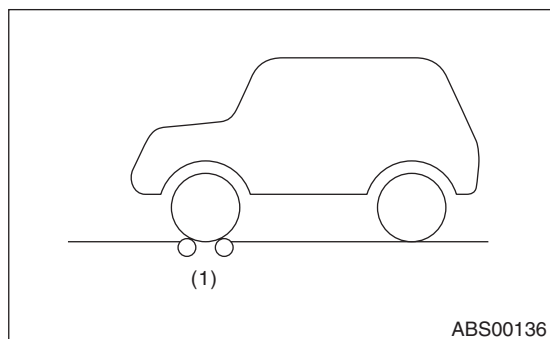

(1) Brake tester

4) Operate the brake tester.

5) Perform VDC sequence control.

<Ref. to VDC-13, VDC Sequence Control.>

6) When the hydraulic unit begins to work, check the following work sequence.

(1) The FL wheel performs compression, hold and decompression in sequence, and subsequently the FR wheel repeats the cycle.

(2) The RR wheel performs compression, hold and decompression in sequence, and subsequently the RL wheel repeats the cycle.

7) Read values indicated on the brake tester and check if the fluctuation of the values between decompression and compression meets specification.

	Front wheel	Rear wheel
When pressurized	2,000 N (204 kgf, 450 lbf) or more	2,000 N (204 kgf, 450 lbf) or more
When depressurized	500 N (51 kgf, 112 lbf) or less	500 N (51 kgf, 112 lbf) or less

8) After the inspection, depress the brake pedal and check that it is not abnormally hard, and tightness is normal.

VDC Control Module and Hydraulic Control Unit (VDCCM&H/U)

VEHICLE DYNAMICS CONTROL (VDC)

Brought to you by Eris Studios
NOT FOR RESALE

D: REPLACEMENT

CAUTION:

- Because the pressure sensor built into the H/U is easily damaged by static electricity, start the operation after performing static electricity measures.
- Be careful not to touch the sensors in the H/U to prevent damage.
- Because the seal of the VDCCM cannot be replaced, do not pull or peel it by lifting it up.
- Because the screw of the H/U will become slightly worn in every replacement procedure, 5 times is the maximum number of times for replacement. If a problem is found such as not being able to torque the screw to specifications even before 5 replacement operations are performed, replace the H/U body.
- When installing the VDCCM, always use new screws.
- When the sealing surface of the VDCCM or H/U is dirty or damaged and it cannot be cleaned or repaired, replace with a new part.

1) Remove the VDCCM&H/U. <Ref. to VDC-7, REMOVAL, VDC Control Module and Hydraulic Control Unit (VDCCM&H/U).>

2) To prevent entry of foreign objects and brake fluid leakage, plug the oil pressure port of the VDCCM&H/U using a screw plug, etc.

3) Set the pump motor section of the removed VDCCM&H/U face down on a vise.

NOTE:

Before securing a part in a vise, place cushioning material such as wood blocks, aluminum plate or cloth between the part and the vise.

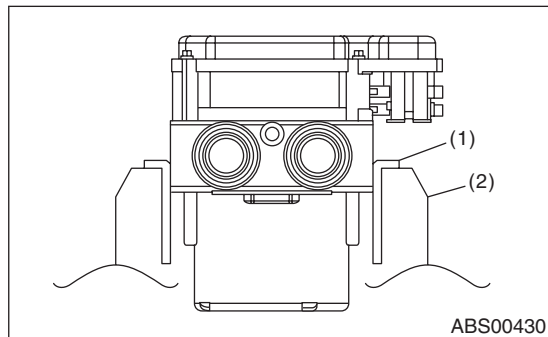

- (1) Aluminum plate, etc.
- (2) Vise

4) Using TORX® bit E5, remove the four screws of VDCCM.

NOTE:

These screws cannot be reused.

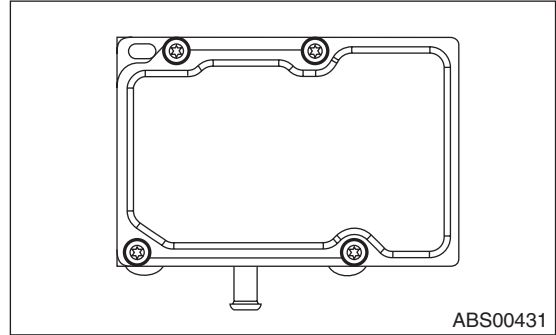

5) Slowly pull out the VDCCM upward from the H/U.

NOTE:

To prevent damaging of coil section, remove the VDCCM straight up from H/U without twisting.

6) Make sure there is no dirt or damage on the sealing surface of the H/U.

CAUTION:

- Do not clean the VDCCM&H/U by applying compressed air.
- Even if damage is found on the H/U seal, do not attempt repair by filing or with a metal scraper. To remove the seal residue, always use a plastic scraper. Do not use chemical such as paint thinner, etc., to clean.

7) Position the coil of the new VDCCM to align with the H/U valve.

8) To prevent deformation of the VDCCM housing cover, hold the corner of VDCCM and install it to the H/U without tilting.

9) Using a TORX® bit E5, attach/tighten new screws in the order of (1) through (4).

CAUTION:

Always use new screws.

Tightening torque:

1.5 N·m (0.15 kgf·m, 1.1 ft·lb)

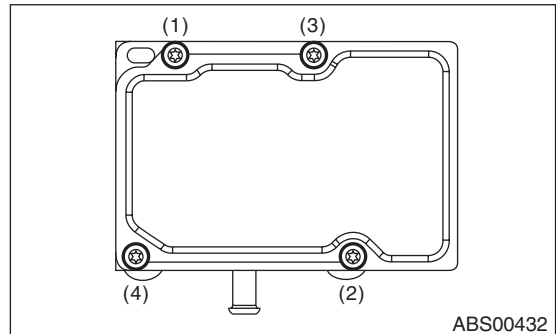

10) Check that there is no foreign matter in mating surface between the VDCCM&H/U.

11) Using a TORX® bit E5, tighten the screws in the order of (1) through (4) again.

Tightening torque:

3 N·m (0.3 kgf·m, 2.2 ft·lb)

12) Check that there is no gap in the mating surface between VDCCM&H/U.

13) Install the VDCCM&H/U to the vehicle.

14) Bleed air from the brake system.

15) Perform the selection•registration operation of parameter. <Ref. to VDC(diag)-18, PARAMETER SELECTION, OPERATION, Subaru Select Monitor.>

NOTE:

- After replacing the VDCCM, be sure to perform the selection•registration operation of parameter.
- For the selection and registration of parameter, the Subaru Select Monitor is required.
- When no data is registered, ABS/EBD/VDC warning light illuminates and the DTC “Parameter selection failure” is detected.

16) Check the parameter to confirm that the applied models and grades of the relevant vehicle are included. <Ref. to VDC(diag)-18, PARAMETER CHECK, OPERATION, Subaru Select Monitor.>

17) If the applied models and grades of the relevant vehicle are not included, perform the selection•registration operation of parameter with the {Confirm Parameter} screen again. <Ref. to VDC(diag)-18, PARAMETER SELECTION, OPERATION, Subaru Select Monitor.>

18) Execute Clear Memory after parameter selection and registration operations because the DTC for “Parameter selection failure” is memorized.

E: ADJUSTMENT

When the following replacement, removal and installation are performed, be sure to perform the centering of the steering angle sensor and zero point setting of yaw rate & lateral G sensor.

- VDCCM&H/U
- Steering angle sensor
- Yaw rate & lateral G sensor
- Steering wheel parts (Including airbag)
- Suspension parts
- Wheel alignment adjustment

1) Park the vehicle straight on a level surface.

(Engine operation in the “P” or “N” range)

2) Check that steering wheel is positioned at the center. (When the center position is not correct, adjust the wheel alignment.)

3) Set the Subaru Select Monitor to the vehicle, and select {Set up mode for Neutral of Steering Angle Sensor & Lateral G Sensor 0 point} in the “Function check sequence” screen. (Follow the steps on the display.)

4) On the “Brake Control System” display screen, select {Current Data Display & Save}, and check that the steering angle sensor shows “0 deg”.

5) When the “0 deg” is not displayed, repeat the above steps and check that the “0 deg” is displayed.

6) Drive the vehicle for 10 minutes, and check that the ABS and VDC warning light is not illuminated.

7) Check that there is no unnecessary VDC operation or steering control loss. If there is a problem, repeat the steps above.

3. ABS Sequence Control

A: OPERATION

<Ref. to ABS-10, OPERATION, ABS Sequence Control.>

1. ABS SEQUENCE CONTROL WITH SUBARU SELECT MONITOR

<Ref. to ABS-10, ABS SEQUENCE CONTROL WITH SUBARU SELECT MONITOR, OPERATION, ABS Sequence Control.>

2. CONDITIONS FOR ABS SEQUENCE CONTROL

<Ref. to ABS-11, CONDITIONS FOR ABS SEQUENCE CONTROL, OPERATION, ABS Sequence Control.>

B: SPECIFICATION

1. CONDITIONS FOR COMPLETION OF ABS SEQUENCE CONTROL

<Ref. to ABS-12, CONDITIONS FOR COMPLETION OF ABS SEQUENCE CONTROL, SPECIFICATION, ABS Sequence Control.>

4. VDC Sequence Control

A: OPERATION

- 1) While the VDC sequence control is performed, the operation of the hydraulic unit can be checked using the brake tester or pressure gauge after the hydraulic unit solenoid valve is operated.
- 2) VDC sequence control can be started by Subaru Select Monitor.

1. VDC SEQUENCE CONTROL WITH SUBARU SELECT MONITOR

NOTE:

In the event of any trouble, sequence control will not operate.

- 1) Connect the Subaru Select Monitor to data link connector under the driver's side instrument panel lower cover.
- 2) Turn the ignition switch to ON.
- 3) Run the "PC application help for Subaru Select Monitor".
- 4) Set the Subaru Select Monitor to "Brake Control" mode.
- 5) When the "VDC Inspection Mode" is selected from the "Function check sequence" menu, the "VDC sequence control" will start.
- 6) Operation points will be displayed on Subaru Select Monitor.

VDC Sequence Control

VEHICLE DYNAMICS CONTROL (VDC)

Brought to you by Eris Studios
NOT FOR RESALE

2. CONDITIONS FOR VDC SEQUENCE CONTROL

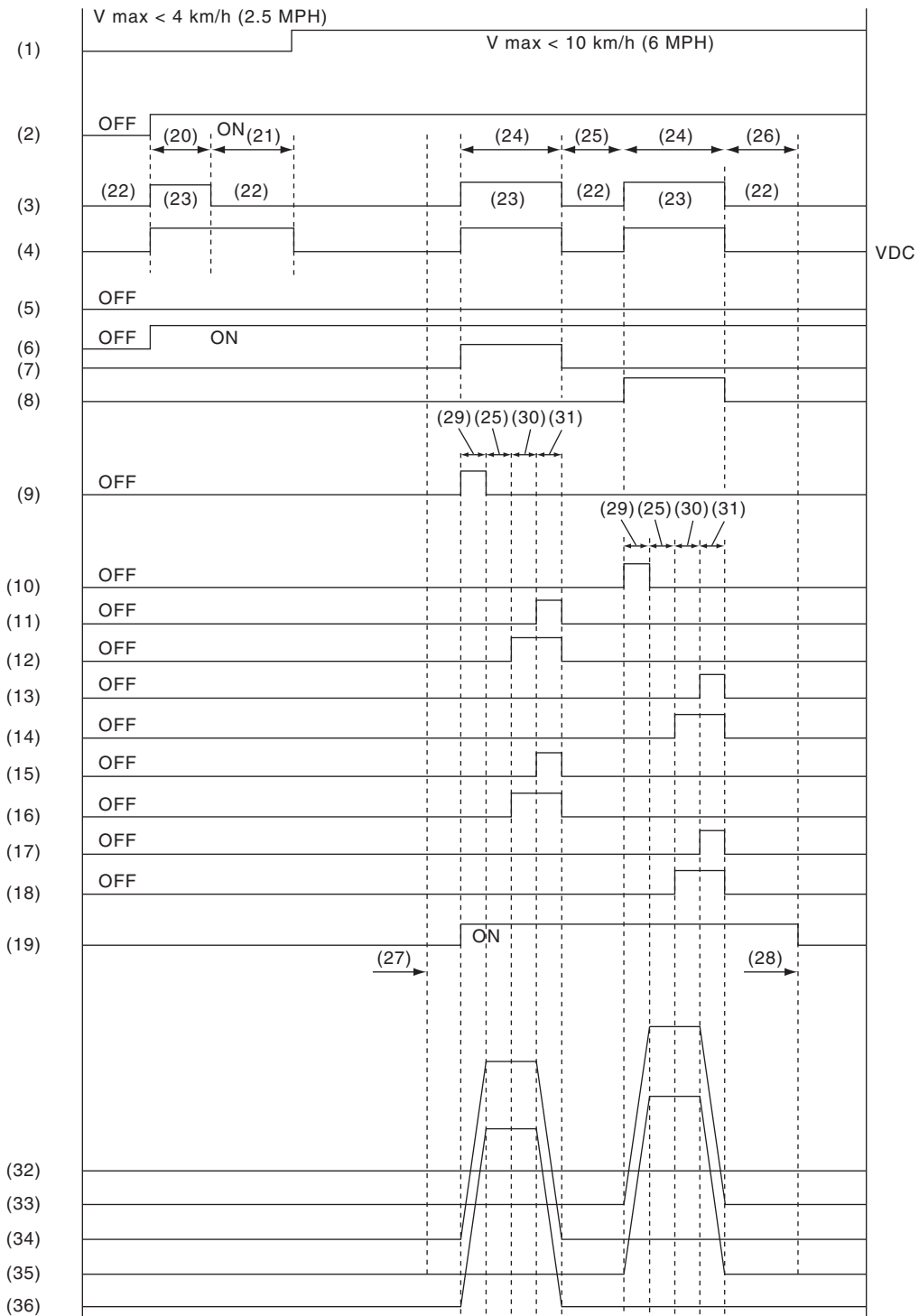

VDC00275

- | | | |
|-------------------------------|-----------------------------|---------------------------------|
| (1) All wheel speed | (13) FR decompression valve | (25) 1 second |
| (2) Ignition key | (14) FR compression valve | (26) 1.6 seconds |
| (3) ABS warning light | (15) RR decompression valve | (27) Point A |
| (4) VDC warning light | (16) RR compression valve | (28) Reset |
| (5) Stop light switch | (17) RL decompression valve | (29) 0.8 seconds |
| (6) Valve relay | (18) RL compression valve | (30) 1.2 seconds |
| (7) VDC switching valve 1 FL | (19) Pump motor | (31) 0.4 seconds |
| (8) VDC switching valve 1 FR | (20) 1.5 seconds | (32) Master cylinder pressure |
| (9) VDC switching valve 2 FL | (21) Approx. 3 seconds | (33) FR wheel cylinder pressure |
| (10) VDC switching valve 2 FR | (22) Light OFF | (34) FL wheel cylinder pressure |
| (11) FL decompression valve | (23) Light ON | (35) RL wheel cylinder pressure |
| (12) FL compression valve | (24) 3.4 seconds | (36) RR wheel cylinder pressure |

NOTE:

The control operation starts from point A.

B: SPECIFICATION

1. CONDITIONS FOR COMPLETION OF VDC SEQUENCE CONTROL

When the following conditions develop, the VDC sequence control stops and VDC operation is returned to the normal control mode.

- 1) When the speed of at least one wheel reaches 10 km/h (6 MPH).
- 2) When the brake pedal is pressed during sequence control and the stop light switch is set to ON.
- 3) After completion of VDC sequence control.
- 4) When a malfunction is detected.

Yaw Rate and Lateral G Sensor

VEHICLE DYNAMICS CONTROL (VDC)

Brought to you by Eris Studios
NOT FOR RESALE

5. Yaw Rate and Lateral G Sensor

A: REMOVAL

- 1) Disconnect the ground cable from the battery.
- 2) Remove the console box.
<Ref. to EI-47, Console Box.>
- 3) Disconnect the connector from yaw rate & lateral G sensor.
- 4) Remove the yaw rate & lateral G sensor.

CAUTION:

Do not drop or hit the yaw rate & lateral G sensor.

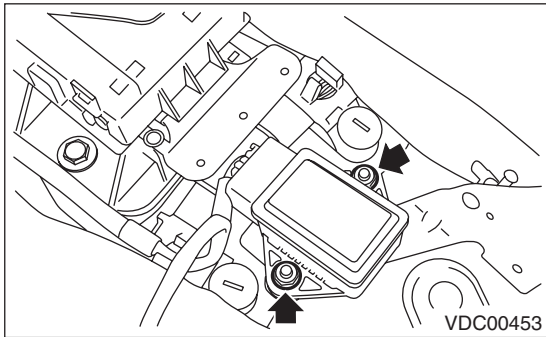

B: INSTALLATION

Install in the reverse order of removal.

Tightening torque:

7.5 N·m (0.76 kgf-m, 5.5 ft-lb)

CAUTION:

After completion of installation, set the following two positions.

- Positioning to the center of steering angle sensor
- Positioning the yaw rate & lateral G sensors to zero.

The above procedure is required VDCCM&H/U to identify the vehicle position afterward. For the setting procedures of the 2 steps above, refer to “VDC Control Module and Hydraulic Control Unit (VDCCM&H/U)”. <Ref. to VDC-11, ADJUSTMENT, VDC Control Module and Hydraulic Control Unit (VDCCM&H/U).>

C: INSPECTION

1. YAW RATE & LATERAL G SENSOR SIGNAL

Step	Check	Yes	No
1 CHECK YAW RATE & LATERAL G SENSOR. 1) Turn the ignition switch to OFF. 2) Connect the Subaru Select Monitor connector to the data link connector. 3) Turn the ignition switch to ON. 4) Set the Subaru Select Monitor to “Brake Control System” mode. 5) Select {Current Data Display & Save}. 6) Read the output of the yaw rate & lateral G sensor.	Are the indicated values when the vehicle is placed horizontally, Lateral G sensor: $-1.5 - 1.5 \text{ m/s}^2$, Yaw rate sensor: $-4 - 4 \text{ deg/s}$?	Go to step 2.	Repair the harness connector between yaw rate & lateral G sensor and VDCCM&H/U. Or replace the yaw rate & lateral G sensor.
2 CHECK VEHICLE.	Is the vehicle an AT model?	Go to step 5.	Go to step 3.
3 CHECK G SENSOR. 1) Remove the console box. 2) Remove the yaw rate & lateral G sensor from vehicle without disconnecting the connector. 3) Read the display of Subaru Select Monitor. NOTE: When the yaw rate & lateral G sensor is moved with its power supply on, DTC of yaw rate & lateral G sensor may be recorded.	When the yaw rate & lateral G sensor is inclined 90° forward, is the indicated value $6.8 - 12.8 \text{ m/s}^2$?	Go to step 4.	Repair the harness connector between yaw rate & lateral G sensor and VDCCM&H/U. Or replace the yaw rate & lateral G sensor.
4 CHECK G SENSOR. Read the display of Subaru Select Monitor. NOTE: When the yaw rate & lateral G sensor is moved with its power supply on, DTC of yaw rate & lateral G sensor may be recorded.	When the yaw rate & lateral G sensor is inclined 90° backward, is the indicated value $-6.8 - -12.8 \text{ m/s}^2$?	Go to step 5.	Repair the harness connector between yaw rate & lateral G sensor and VDCCM&H/U. Or replace the yaw rate & lateral G sensor.

Yaw Rate and Lateral G Sensor

VEHICLE DYNAMICS CONTROL (VDC)

Brought to you by Eris Studios
NOT FOR SALE

	Step	Check	Yes	No
5	<p>CHECK G SENSOR. 1) Remove the console box. (AT model only) 2) Remove the yaw rate & lateral G sensor from vehicle without disconnecting the connector. (AT model only) 3) Read the display of Subaru Select Monitor. NOTE: When the yaw rate & lateral G sensor is moved with its power supply on, DTC of yaw rate & lateral G sensor may be recorded.</p>	<p>Is the value 6.8 — 12.8 m/s² when the yaw rate & lateral G sensor is inclined 90° to the right?</p>	<p>Go to step 6.</p>	<p>Repair the harness connector between yaw rate & lateral G sensor and VDCCM&H/U. Or replace the yaw rate & lateral G sensor.</p>
6	<p>CHECK G SENSOR. Read the display of Subaru Select Monitor. NOTE: When the yaw rate & lateral G sensor is moved with its power supply on, DTC of yaw rate & lateral G sensor may be recorded.</p>	<p>Is the value -6.8 — -12.8 m/s² when the yaw rate & lateral G sensor is inclined 90° to the left?</p>	<p>Yaw rate & lateral G sensors are normal.</p>	<p>Repair the harness connector between yaw rate & lateral G sensor and VDCCM&H/U. Or replace the yaw rate & lateral G sensor.</p>

Steering Angle Sensor

VEHICLE DYNAMICS CONTROL (VDC)

Brought to you by Eris Studios
NOT FOR RESALE

6. Steering Angle Sensor

A: REPLACEMENT

CAUTION:

- Do not perform the removal except when the replacement.
- If the sensor needs replacement, replace along with the combination switch assembly once every three times for the protection of the threaded portion.

1) Set the steering wheel in a straight-ahead position.

2) Disconnect the ground cable from the battery.

3) Remove the airbag module.

<Ref. to AB-16, REMOVAL, Driver's Airbag Module.>

WARNING:

Always refer to "Airbag System" when performing the airbag module repair service.

<Ref. to AB-5, CAUTION, General Description.>

4) Remove the steering wheel.

<Ref. to PS-13, REMOVAL, Steering Wheel.>

5) Remove the screws and remove the steering column lower cover.

6) Remove the two screws securing the steering column upper cover.

7) Disconnect the connector of roll connector and steering angle sensor.

8) Remove the screws which secure the roll connector to steering column.

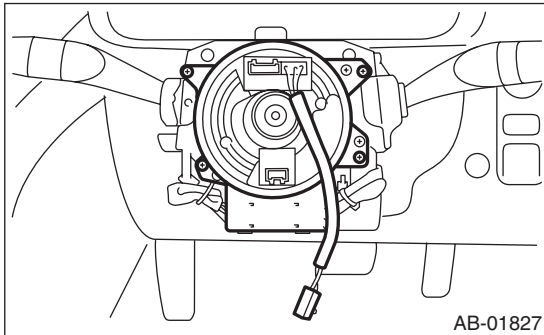

9) Remove the vinyl tape binding the harness, and remove the steering angle sensor from roll connector.

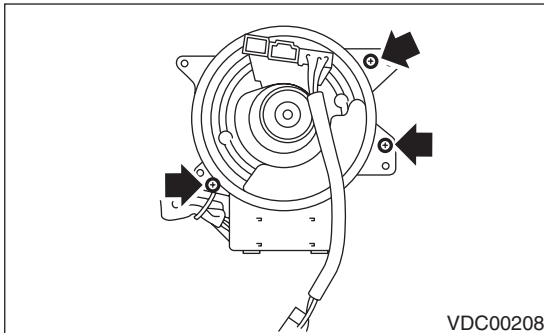

10) Turn the protrusion portion of new steering angle sensor to match the alignment mark of inspection hole.

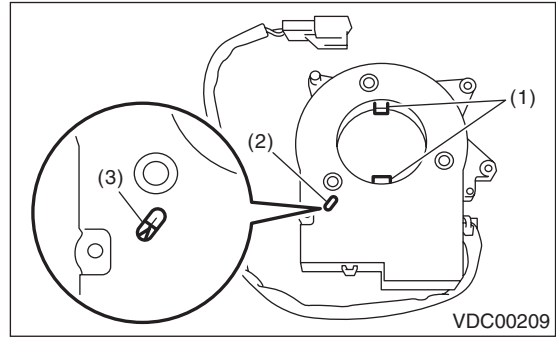

- (1) Protrusion portion
- (2) Inspection hole
- (3) Alignment mark

CAUTION:

Be careful not to allow foreign matter to enter into inspection hole.

11) Align the center of roll connector.

<Ref. to AB-27, INSTALLATION, Roll Connector.>

12) Apply the grease provided with the new part on the 4 locations of the protrusion on the steering angle sensor.

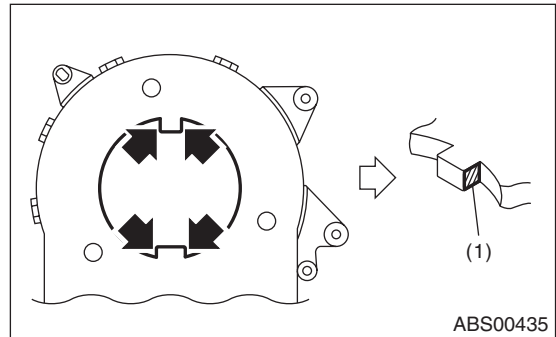

- (1) Grease application location

13) Align the position of the protrusion and install roll connector to steering angle sensor.

Tightening torque:

0.5 N·m (0.05 kgf·m, 0.36 ft·lb)

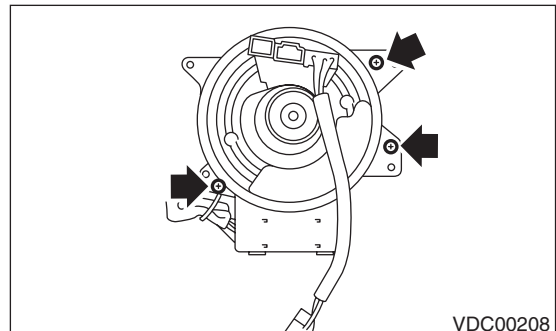

14) Install the roll connector to combination switch and bind the harness with vinyl tape as originally bound.

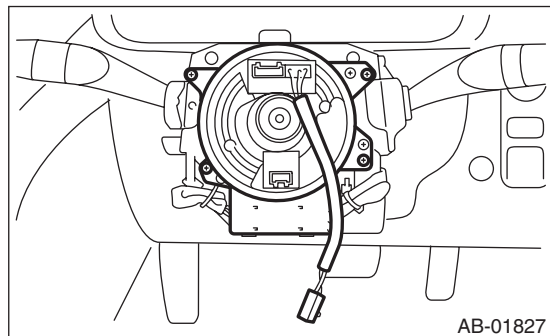

15) Install the steering wheel.
<Ref. to PS-13, INSTALLATION, Steering Wheel.>

Tightening torque:

44 N·m (4.5 kgf-m, 32.5 ft-lb)

16) Install the airbag module to the steering wheel.
<Ref. to AB-16, INSTALLATION, Driver's Airbag Module.>

WARNING:

Always refer to "Airbag System" before performing the service operation.

<Ref. to AB-5, CAUTION, General Description.>

17) Connect the ground cable to the battery.

CAUTION:

After completion of installation, adjust the following two positions.

- Positioning to the center of steering angle sensor
- Positioning the yaw rate & lateral G sensors to zero.

The above procedure is required for the VDC-CM to identify vehicle position afterward. For the setting procedures of the 2 steps above, refer to "VDC Control Module and Hydraulic Control Unit (VDCCM&H/U)". <Ref. to VDC-11, ADJUSTMENT, VDC Control Module and Hydraulic Control Unit (VDCCM&H/U).>

Front ABS Wheel Speed Sensor

VEHICLE DYNAMICS CONTROL (VDC)

Brought to you by Eris Studios
NOT FOR RESALE

7. Front ABS Wheel Speed Sensor

A: NOTE

Vehicles equipped with VDC have the same ABS wheel speed sensor as installed on vehicles equipped with ABS. Refer to “Front ABS Wheel Speed Sensor” for removal, installation and inspection procedures.

<Ref. to ABS-13, Front ABS Wheel Speed Sensor.>

8. Rear ABS Wheel Speed Sensor

A: NOTE

Vehicles equipped with VDC have the same ABS wheel speed sensor as installed on vehicles equipped with ABS. Refer to "Rear ABS Wheel Speed Sensor" for removal, installation and inspection procedures.
<Ref. to ABS-15, Rear ABS Wheel Speed Sensor.>

9. Front Magnetic Encoder

A: NOTE

Vehicles equipped with VDC have the same magnetic encoder as installed on vehicles equipped with ABS. Refer to “Front Magnetic Encoder” for removal, installation and inspection procedures.

<Ref. to ABS-16, Front Magnetic Encoder.>

10.Rear Magnetic Encoder

A: NOTE

Vehicles equipped with VDC have the same magnetic encoder as installed on vehicles equipped with ABS. Refer to "Rear Magnetic Encoder" for removal, installation and inspection procedures.

<Ref. to ABS-17, Rear Magnetic Encoder.>

11.VDC OFF Switch

A: REMOVAL

- 1) Remove the instrument panel lower cover.
- 2) Remove the screws, and then remove the VDC OFF switch.

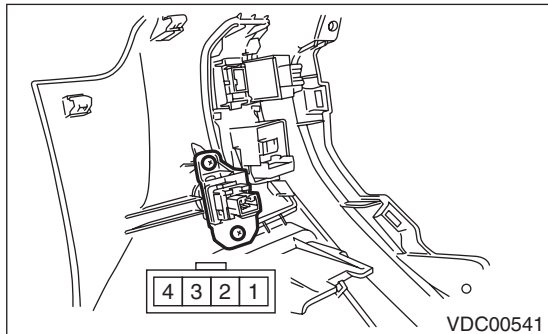

B: INSTALLATION

Install in the reverse order of removal.

C: INSPECTION

Measure the resistance between the VDC OFF switch terminals.

Switch position	Terminal No.	Standard
OFF	2 — 3	1 M Ω or more
ON	2 — 3	Less than 1 Ω

If it is not within the standard, replace the VDC OFF switch.