

Brought to you by Eris Studios
NOT FOR RESALE

VEHICLE DYNAMICS CONTROL (VDC) (DIAGNOSTICS)

Basic Diagnostic Procedure

VEHICLE DYNAMICS CONTROL (VDC) (DIAGNOSTICS)

Brought to you by Eris Studios
NOT FOR RESALE

1. Basic Diagnostic Procedure

A: PROCEDURE

CAUTION:

Remove foreign matter (dust, water, oil etc.) from the VDCCM&H/U connector during removal and installation.

NOTE:

- To check the harness for broken wires or short circuits, shake problem spot or connector.
- Refer to "Check List for Interview". <Ref. to VDC(diag)-4, Check List for Interview.>

	Step	Check	Yes	No
1	<p>CHECK PRE-INSPECTION.</p> <p>1) Ask the customer when and how the trouble occurred using the interview check list. <Ref. to VDC(diag)-4, Check List for Interview.></p> <p>2) Before performing diagnostics, check the component which might affect VDC problems. <Ref. to VDC(diag)-8, INSPECTION, General Description.></p>	Is the component that might influence the VDC problem normal?	Go to step 2.	Repair or replace each component.
2	<p>CHECK INDICATION OF DTC.</p> <p>1) Turn the ignition switch to OFF.</p> <p>2) Connect the Subaru Select Monitor to the data link connector.</p> <p>3) Turn the ignition switch to ON and run the Subaru Select Monitor.</p> <p>4) Read the DTC using the Subaru Select Monitor. <Ref. to VDC(diag)-22, OPERATION, Read Diagnostic Trouble Code (DTC).></p> <p>NOTE: If the communication function of the Subaru Select Monitor cannot be executed normally, check the communication circuit. <Ref. to VDC(diag)-19, COMMUNICATION FOR INITIALIZING IMPOSSIBLE, INSPECTION, Subaru Select Monitor.></p> <p>5) Record all DTCs and freeze frame data.</p>	Is DTC displayed on the Subaru Select Monitor?	Go to step 4.	Go to step 3.
3	<p>PERFORM GENERAL DIAGNOSTICS.</p> <p>1) Perform the inspection by referring to "General Diagnostic Table". <Ref. to VDC(diag)-101, INSPECTION, General Diagnostic Table.></p> <p>2) Perform the Clear Memory Mode. <Ref. to VDC(diag)-24, OPERATION, Clear Memory Mode.></p> <p>3) Perform the Inspection Mode. <Ref. to VDC(diag)-23, PROCEDURE, Inspection Mode.></p> <p>4) Read the DTC. <Ref. to VDC(diag)-22, OPERATION, Read Diagnostic Trouble Code (DTC).></p> <p>5) Check the DTC is not displayed.</p>	Do the VDC warning light and ABS warning light go off after starting the engine?	Finish the diagnosis.	Check the combination meter circuit. <Ref. to VDC(diag)-28, ABS WARNING LIGHT DOES NOT GO OFF, Warning Light Illumination Pattern.> <Ref. to VDC(diag)-29, VDC WARNING LIGHT AND VDC OFF INDICATOR LIGHT DO NOT GO OFF, Warning Light Illumination Pattern.>

Basic Diagnostic Procedure

VEHICLE DYNAMICS CONTROL (VDC) (DIAGNOSTICS)

Brought to you by Eriss Studios
NOT FOR SALE

	Step	Check	Yes	No
4	PERFORM DIAGNOSIS. 1) Refer to "List of Diagnostic Trouble Code (DTC)". NOTE: For the DTC list, refer to "List of Diagnostic Trouble Code (DTC)". <Ref. to VDC(diag)-32, LIST, List of Diagnostic Trouble Code (DTC).> 2) Correct the cause of trouble. 3) Perform the Clear Memory Mode. <Ref. to VDC(diag)-24, OPERATION, Clear Memory Mode.> 4) Perform the Inspection Mode. <Ref. to VDC(diag)-23, PROCEDURE, Inspection Mode.> 5) Read the DTC. <Ref. to VDC(diag)-22, OPERATION, Read Diagnostic Trouble Code (DTC).>	Is DTC displayed?	Repeat step 4 until DTC is not shown.	Finish the diagnosis.

Check List for Interview

VEHICLE DYNAMICS CONTROL (VDC) (DIAGNOSTICS)

Brought to you by Eris Studios
NOT FOR RESALE

2. Check List for Interview

A: CHECK

Check the following item about the vehicle's state.

1. STATE OF ABS WARNING LIGHT

ABS warning light illuminates.	<input type="checkbox"/> Always <input type="checkbox"/> Sometimes <input type="checkbox"/> Only once <input type="checkbox"/> Does not come on • When/How long does it illuminate?		
Ignition key position	<input type="checkbox"/> LOCK <input type="checkbox"/> ACC <input type="checkbox"/> ON (before starting engine) <input type="checkbox"/> START <input type="checkbox"/> ON (after starting engine, engine is running) <input type="checkbox"/> ON (after starting engine, engine is at a standstill)		
Timing	<input type="checkbox"/> Immediately after turning the ignition switch to ON <input type="checkbox"/> Immediately after turning the ignition switch to START		
	<input type="checkbox"/> While accelerating	—	km/h
		—	MPH
	<input type="checkbox"/> While driving at a constant speed	km/h	MPH
	<input type="checkbox"/> While decelerating	—	km/h
		—	MPH
	<input type="checkbox"/> When turning to the right	Steering angle:	deg
		Steering time:	Sec.
	<input type="checkbox"/> When turning to the left	Steering angle:	deg
		Steering time:	Sec.
	<input type="checkbox"/> When other electrical parts are operating • Part name: • Operating condition:		

Check List for Interview

VEHICLE DYNAMICS CONTROL (VDC) (DIAGNOSTICS)

Brought to you by Eris Studios
NOT FOR SALE

2. STATE OF VDC WARNING LIGHT AND VDC OFF INDICATOR LIGHT

VDC warning light and VDC OFF indicator light illuminate.	<input type="checkbox"/> Always <input type="checkbox"/> Sometimes <input type="checkbox"/> Only once <input type="checkbox"/> Does not come on • When/How long does it illuminate?		
Ignition key position	<input type="checkbox"/> LOCK <input type="checkbox"/> ACC <input type="checkbox"/> ON (before starting engine) <input type="checkbox"/> START <input type="checkbox"/> ON (after starting engine, engine is running) <input type="checkbox"/> ON (after starting engine, engine is at a standstill)		
Timing	<input type="checkbox"/> Immediately after turning the ignition switch to ON <input type="checkbox"/> Immediately after turning the ignition switch to START		
	<input type="checkbox"/> While accelerating	—	km/h
		—	MPH
	<input type="checkbox"/> While driving at a constant speed	km/h	MPH
	<input type="checkbox"/> While decelerating	—	km/h
		—	MPH
	<input type="checkbox"/> When turning to the right	Steering angle:	deg
		Steering time:	Sec.
	<input type="checkbox"/> When turning to the left	Steering angle:	deg
		Steering time:	Sec.
<input type="checkbox"/> When other electrical parts are operating • Part name: • Operating condition:			

3. STATE OF VDC INDICATOR LIGHT

VDC operation indicator light illuminate.	<input type="checkbox"/> Always <input type="checkbox"/> Sometimes <input type="checkbox"/> Only once <input type="checkbox"/> Does not come on • When/How long does it illuminate?		
Ignition key position	<input type="checkbox"/> LOCK <input type="checkbox"/> ACC <input type="checkbox"/> ON (before starting engine) <input type="checkbox"/> START <input type="checkbox"/> ON (after starting engine, engine is running) <input type="checkbox"/> ON (after starting engine, engine is at a standstill)		
Timing	<input type="checkbox"/> Immediately after turning the ignition switch to ON <input type="checkbox"/> Immediately after turning the ignition switch to START		
	<input type="checkbox"/> While accelerating	—	km/h
		—	MPH
	<input type="checkbox"/> While driving at a constant speed	km/h	MPH
	<input type="checkbox"/> While decelerating	—	km/h
		—	MPH
	<input type="checkbox"/> When turning to the right	Steering angle:	deg
		Steering time:	Sec.
	<input type="checkbox"/> When turning to the left	Steering angle:	deg
		Steering time:	Sec.
<input type="checkbox"/> When other electrical parts are operating • Part name: • Operating condition:			

Check List for Interview

VEHICLE DYNAMICS CONTROL (VDC) (DIAGNOSTICS)

Brought to you by Eris Studios
NOT FOR RESALE

4. CONDITIONS UNDER WHICH TROUBLE OCCURS

Environment	a) Weather	<input type="checkbox"/> Fine <input type="checkbox"/> Cloudy <input type="checkbox"/> Rainy <input type="checkbox"/> Snowy <input type="checkbox"/> Others:
	b) Ambient temperature	°C (°F)
	c) Road	<input type="checkbox"/> Inner city <input type="checkbox"/> Suburbs <input type="checkbox"/> Highway <input type="checkbox"/> Local street <input type="checkbox"/> Uphill <input type="checkbox"/> Downhill <input type="checkbox"/> Paved road <input type="checkbox"/> Gravel road <input type="checkbox"/> Muddy road <input type="checkbox"/> Sandy place <input type="checkbox"/> Straight road <input type="checkbox"/> Sharp curve <input type="checkbox"/> Gentle curve <input type="checkbox"/> S-curve <input type="checkbox"/> Road with a slope on both sides <input type="checkbox"/> Others:
	d) Road surface	<input type="checkbox"/> Dry <input type="checkbox"/> Wet <input type="checkbox"/> Covered with fresh snow <input type="checkbox"/> Covered with hardened snow <input type="checkbox"/> Frozen slope <input type="checkbox"/> Others:

Check List for Interview

VEHICLE DYNAMICS CONTROL (VDC) (DIAGNOSTICS)

Brought to you by Eris Studios
NOT FOR SALE

Condition	a) Brakes	Deceleration: G
		<input type="checkbox"/> Continuous / <input type="checkbox"/> Intermittent
	b) Accelerator	Acceleration: G
		<input type="checkbox"/> Continuous / <input type="checkbox"/> Intermittent
	c) Vehicle speed	km/h MPH
		<input type="checkbox"/> Advancing
		<input type="checkbox"/> While accelerating
		<input type="checkbox"/> While decelerating
		<input type="checkbox"/> At low speed
		<input type="checkbox"/> When turning
		<input type="checkbox"/> Others:
	d) Tire inflation pressure	Front RH tire: kPa
		Front LH tire: kPa
		Rear RH tire: kPa
		Rear LH tire: kPa
	e) Degree of wear	Front RH tire:
		Front LH tire:
		Rear RH tire:
		Rear LH tire:
	f) Steering wheel	<input type="checkbox"/> Sharp turning
	<input type="checkbox"/> Gentle turning	
	<input type="checkbox"/> Straight forward motion	
	<input type="checkbox"/> Gentle return	
	<input type="checkbox"/> Sharp return	
g) Tire/Wheel size	<input type="checkbox"/> Specified size	
	<input type="checkbox"/> Except specification ()	
h) Tire variation	<input type="checkbox"/> Summer tire	
	<input type="checkbox"/> Studless tire (Brand:)	
i) Tire chain is attached: <input type="checkbox"/> Yes / <input type="checkbox"/> No		
j) T-type tire is used: <input type="checkbox"/> Yes / <input type="checkbox"/> No		
k) Condition of suspension alignment:		
l) Loading state:		
m) Repair parts are used: <input type="checkbox"/> Yes / <input type="checkbox"/> No		
• Contents:		
n) Others:		

General Description

VEHICLE DYNAMICS CONTROL (VDC) (DIAGNOSTICS)

Brought to you by Eris Studios
NOT FOR RESALE

3. General Description

A: CAUTION

1. SUPPLEMENTAL RESTRAINT SYSTEM “AIRBAG”

Airbag system wiring harness is routed near the ABS wheel speed sensor and VDCCM&H/U.

CAUTION:

- All airbag system wiring harness and connectors are colored yellow. Do not use electrical test equipment on these circuits.
- Be careful not to damage the airbag system wiring harness when servicing the ABS wheel speed sensor and VDCCM&H/U.

B: INSPECTION

Before performing diagnosis, check the following items which might affect VDC problems.

1. BATTERY

Measure the battery voltage and check electrolyte.

Standard voltage:

12 V or more

Specific gravity:

1.260 or more

2. GROUND

Check the tightening torque of ground (GB-5) bolt of VDC.

Tightening torque:

13 N·m (1.3 kgf·m, 9.6 ft-lb)

3. BRAKE FLUID

- 1) Check the brake fluid level.
- 2) Check the brake fluid for leaks.

4. HYDRAULIC UNIT

Check the hydraulic unit.

- When using the brake tester <Ref. to VDC-8, CHECKING THE HYDRAULIC UNIT ABS OPERATION WITH THE BRAKE TESTER, INSPECTION, VDC Control Module and Hydraulic Control Unit (VDCCM&H/U).>
- Without brake tester <Ref. to VDC-8, CHECKING THE HYDRAULIC UNIT ABS OPERATION BY PRESSURE GAUGE, INSPECTION, VDC Control Module and Hydraulic Control Unit (VDCCM&H/U).>

5. BRAKE DRAG

Check for brake drag.

6. BRAKE PAD AND ROTOR

Check the brake pad and rotor.

- Front <Ref. to BR-14, INSPECTION, Front Brake Pad.> <Ref. to BR-15, INSPECTION, Front Disc Rotor.>
- Rear <Ref. to BR-20, INSPECTION, Rear Brake Pad.> <Ref. to BR-22, INSPECTION, Rear Disc Rotor.>

7. TIRE

Check the tire specifications, tire wear and air pressure. <Ref. to WT-2, SPECIFICATION, General Description.>

General Description

VEHICLE DYNAMICS CONTROL (VDC) (DIAGNOSTICS)

Brought to you by Eris Studios
NOT FOR SALE

C: PREPARATION TOOL

1. SPECIAL TOOL

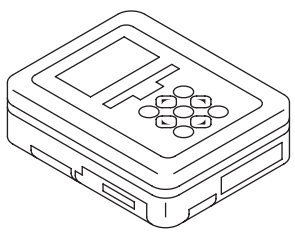
ILLUSTRATION	TOOL NUMBER	DESCRIPTION	REMARKS
 ST1B021XU0	1B021XU0	SUBARU SELECT MONITOR III KIT	Used for troubleshooting for electrical system.

2. GENERAL TOOL

TOOL NAME	REMARKS
Circuit tester	Used for measuring resistance, voltage and current.
Oscilloscope	Used for measuring the sensor.

Electrical Component Location

VEHICLE DYNAMICS CONTROL (VDC) (DIAGNOSTICS)

Brought to you by Eris Studios
NOT FOR RESALE

4. Electrical Component Location

A: LOCATION

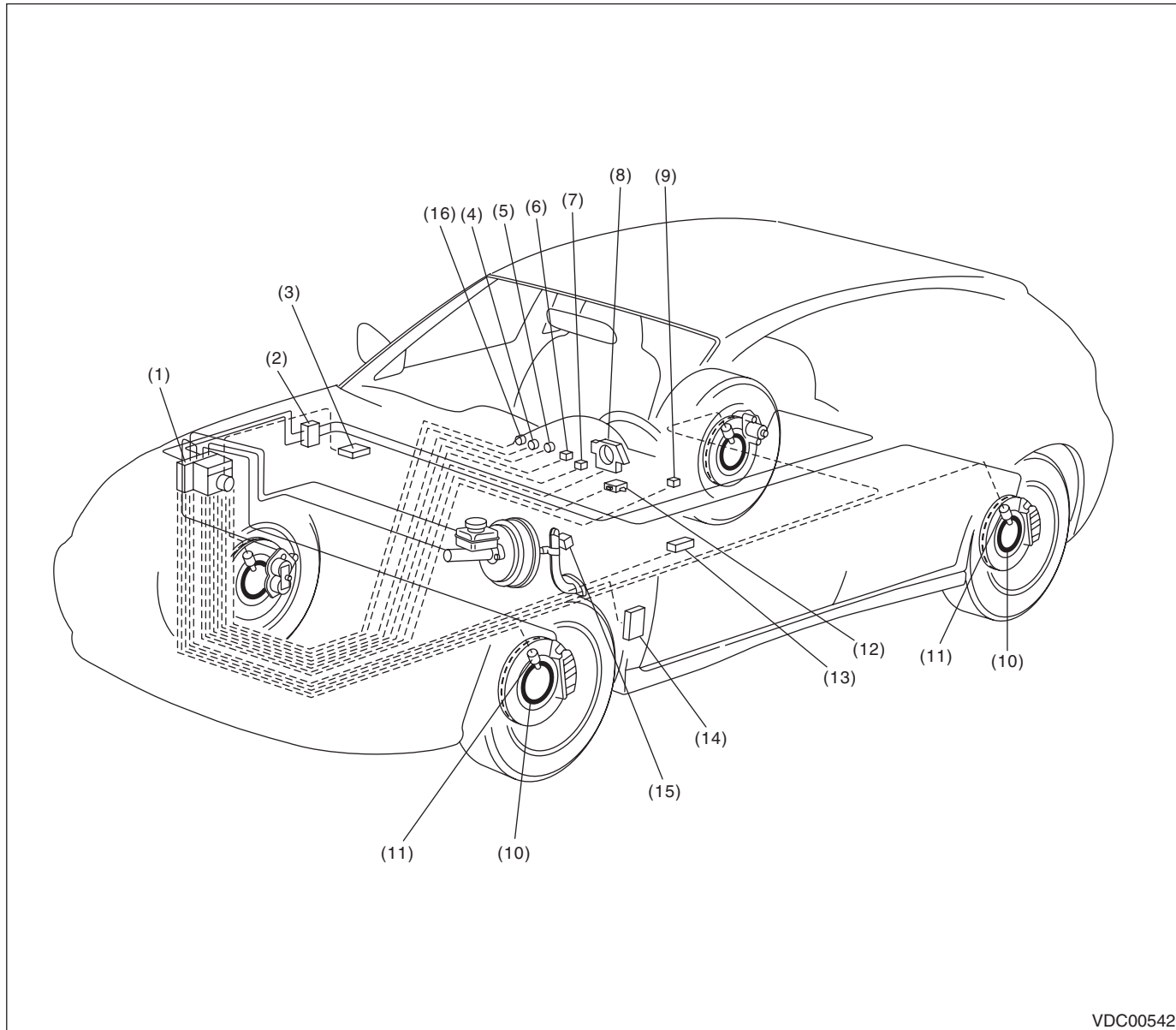

VDC00542

- | | | |
|---|---|--------------------------------------|
| (1) VDC control module and hydraulic control unit (VDCCM&H/U) | (6) VDC indicator light | (11) ABS wheel speed sensor |
| (2) Connector | (7) VDC warning light and VDC OFF indicator light | (12) Yaw rate & lateral G sensor |
| (3) Transmission control module (TCM) | (8) Steering angle sensor | (13) Data link connector |
| (4) Brake warning light (EBD warning light) | (9) VDC OFF switch | (14) Engine control module (ECM) |
| (5) ABS warning light | (10) Magnetic encoder | (15) Stop light switch |
| | | (16) Hill start assist warning light |

Electrical Component Location

VEHICLE DYNAMICS CONTROL (VDC) (DIAGNOSTICS)

Brought to you by *Eriss Studios*
NOT FOR SALE

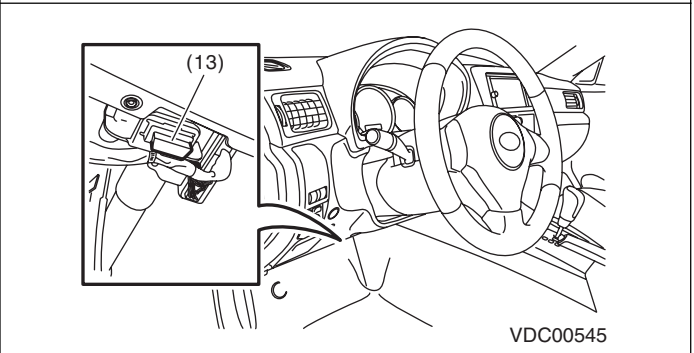
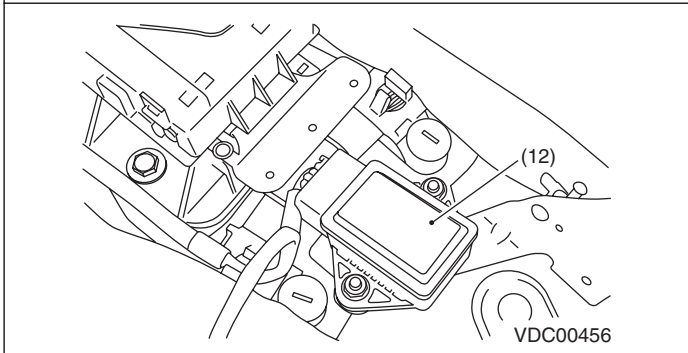
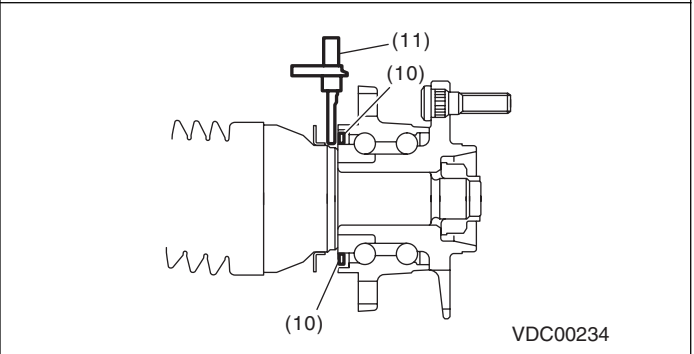
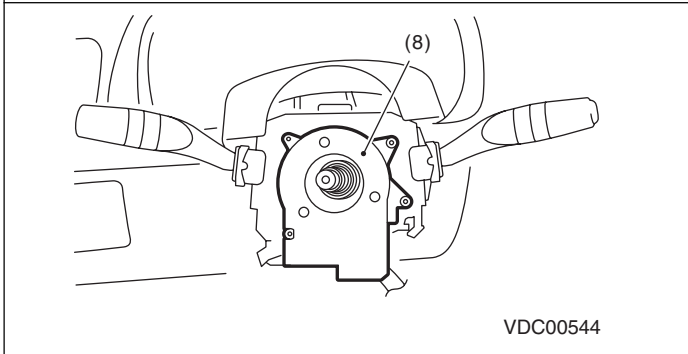
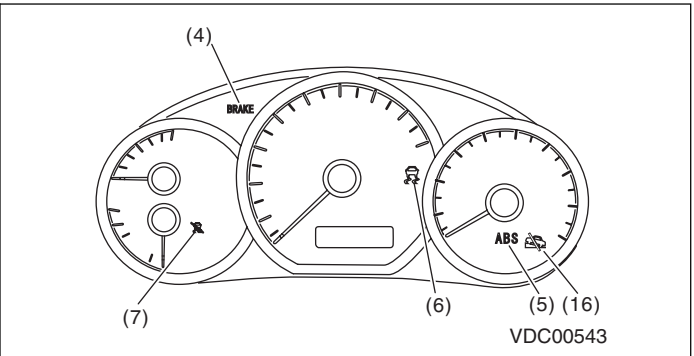
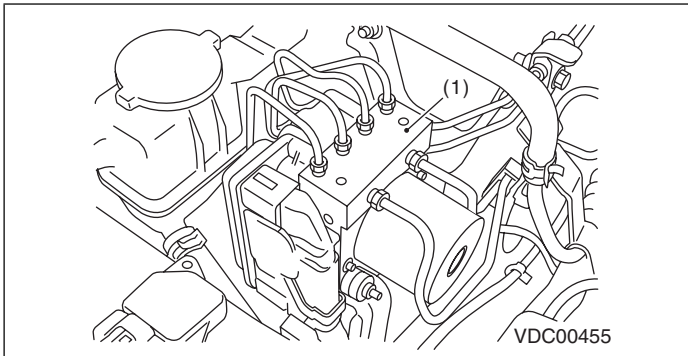

Control Module I/O Signal

VEHICLE DYNAMICS CONTROL (VDC) (DIAGNOSTICS)

Brought to you by Eris Studios
NOT FOR RESALE

5. Control Module I/O Signal

A: ELECTRICAL SPECIFICATION

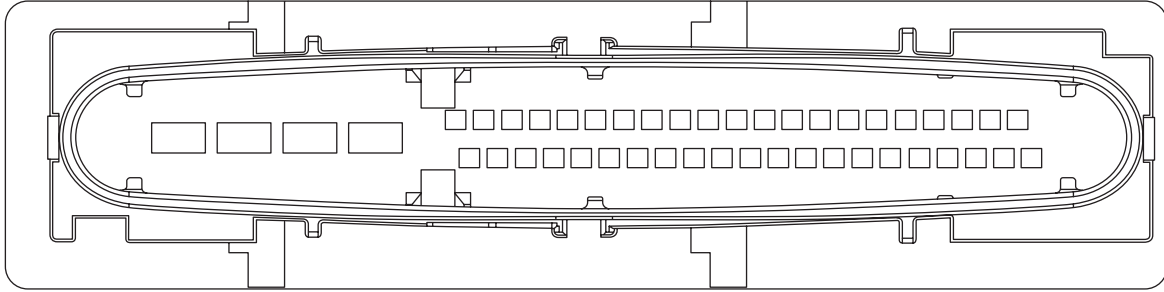

B310

22	23	24	25	1	2	3	4	5	6	7	8	9	10	11	12	13	14	15	16	17	18	19	20	21
				26	27	28	29	30	31	32	33	34	35	36	37	38	39	40	41	42	43	44	45	46

VDC00457

NOTE:

- Terminal numbers in VDCCM&H/U connector are shown in the figure.
- When the connector is removed from the VDCCM&H/U, the ABS warning light, VDC warning light, VDC OFF indicator light, and the hill start assist warning light illuminate.

Control Module I/O Signal

VEHICLE DYNAMICS CONTROL (VDC) (DIAGNOSTICS)

Brought to you by Eris Studios
NOT FOR RESALE

Content		Terminal No. (+) — (-)	Input/Output signal	
			Measured value and measuring conditions	
Power supply		28 — 25	10 — 15 V when the ignition switch is ON.	
ABS wheel speed sensor	Front LH wheel	Power supply	26 — 25	4.5 — 16.5 V
		Signal	1	5.9 — 16.8 mA: Rectangle waveform
	Front RH wheel	Power supply	5 — 25	4.5 — 16.5 V
		Signal	6	5.9 — 16.8 mA: Rectangle waveform
	Rear LH wheel	Power supply	2 — 25	4.5 — 16.5 V
		Signal	27	5.9 — 16.8 mA: Rectangle waveform
	Rear RH wheel	Power supply	3 — 25	4.5 — 16.5 V
		Signal	4	5.9 — 16.8 mA: Rectangle waveform
CAN communication line (+)		35	2.5 — 1.5 V pulse signal	
CAN communication line (-)		10	3.5 — 2.5 V pulse signal	
Valve relay power supply		24 — 25	10 — 15 V when the ignition switch is ON.	
Motor relay power supply		23 — 22	10 — 15 V when the ignition switch is ON.	
Stop light switch		30 — 25	1.5 V or less when the stop light is OFF; otherwise, 10 — 15 V when the stop light is ON.	
Subaru Select Monitor		7 — 25	0 ↔ 12 V pulse (in communication)	
Vehicle speed output signal		33	0 ↔ 12 V pulse	
Ground		25	—	

Control Module I/O Signal

VEHICLE DYNAMICS CONTROL (VDC) (DIAGNOSTICS)

Brought to you by Eris Studios
NOT FOR RESALE

B: WIRING DIAGRAM

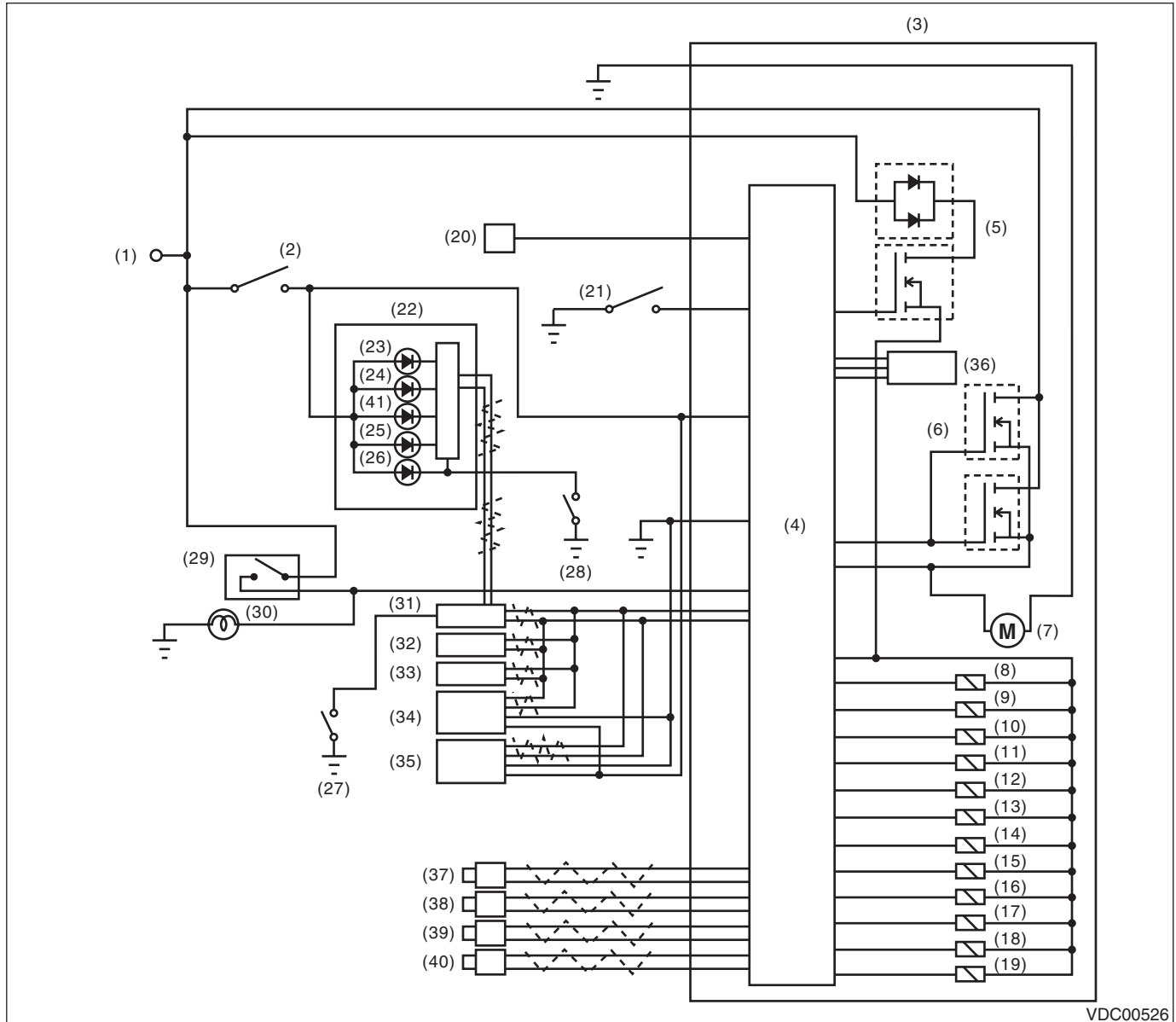

VDC00526

- | | | |
|---|--|--|
| (1) Battery | (15) Rear outlet solenoid valve RH | (28) Brake fluid level switch |
| (2) Ignition switch | (16) Primary cut solenoid valve | (29) Stop light switch |
| (3) VDC control module and hydraulic control unit (VDCCM&H/U) | (17) Primary suction solenoid valve | (30) Stop light |
| (4) VDC control module | (18) Secondary cut solenoid valve | (31) Body integrated unit |
| (5) Valve relay | (19) Secondary suction solenoid valve | (32) Engine control module (ECM) |
| (6) Motor relay | (20) Data link connector | (33) Transmission control module (TCM) |
| (7) Motor | (21) VDC OFF switch | (34) Steering angle sensor |
| (8) Front inlet solenoid valve LH | (22) Combination meter | (35) Yaw rate & lateral G sensor |
| (9) Front outlet solenoid valve LH | (23) VDC indicator light | (36) Pressure sensor |
| (10) Front inlet solenoid valve RH | (24) VDC warning light and VDC OFF indicator light | (37) Front ABS wheel speed sensor LH |
| (11) Front outlet solenoid valve RH | (25) ABS warning light | (38) Front ABS wheel speed sensor RH |
| (12) Rear inlet solenoid valve LH | (26) Brake warning light | (39) Rear ABS wheel speed sensor LH |
| (13) Rear outlet solenoid valve LH | (27) Parking brake switch | (40) Rear ABS wheel speed sensor RH |
| (14) Rear inlet solenoid valve RH | | (41) Hill start assist warning light |

Brought to you by Eris Studios
NOT FOR SALE

6. Subaru Select Monitor

A: OPERATION

1. READ DIAGNOSTIC TROUBLE CODE (DTC)

1) Prepare the Subaru Select Monitor kit. <Ref. to VDC(diag)-9, SPECIAL TOOL, PREPARATION TOOL, General Description.>

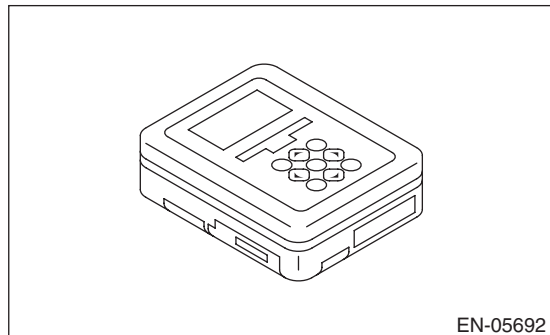

2) Prepare PC with Subaru Select Monitor installed.
3) Connect the SDI (Subaru Diagnostic Interface) to the PC USB port (exclusively for Subaru Selector Monitor) using a USB cable.

NOTE:

Port exclusively for Subaru Select Monitor refers to the USB port used when installing Subaru Select Monitor.

4) Connect the diagnosis cable to the SDI.
5) Connect the SDI to the data link connector located in the lower portion of the instrument panel (on the driver's side).

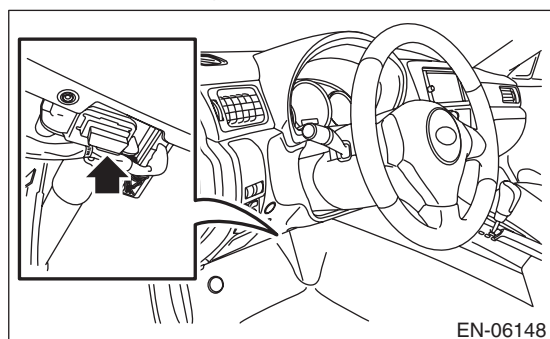

CAUTION:

Do not connect scan tools other than the Subaru Select Monitor.

6) Start the PC.
7) Turn the ignition switch to ON (engine OFF) and run the "PC application for Subaru Select Monitor".
8) On the «Main Menu», select {Each System Check}.
9) On the «System Selection Menu», select {Brake Control}.
10) Click the [OK] button after the {VDC} is displayed.
11) On the «Brake Control Diagnosis» screen, select {DTC Display}.

12) Record the DTC and data.

NOTE:

- For detailed operation procedure, refer to the «help on PC application for Subaru Select Monitor».
- For details concerning DTCs, refer to "List of Diagnostic Trouble Code (DTC)". <Ref. to VDC(diag)-32, List of Diagnostic Trouble Code (DTC).>
- Up to 3 DTCs are displayed in the order of detection.
- If a particular DTC is not stored in memory properly at the occurrence of problem (due to a drop in VDCCM&H/U power supply etc.), the DTC suffixed with a question mark "?" is displayed on Subaru Select Monitor display screen. This shows it may be an unreliable reading.

13) If VDC and Subaru Select Monitor cannot communicate, check the communication circuit. <Ref. to VDC(diag)-19, COMMUNICATION FOR INITIALIZING IMPOSSIBLE, INSPECTION, Subaru Select Monitor.>

Display	Contents to be monitored
Current	The current DTC is displayed on Subaru Select Monitor display screen.
Previous	The latest DTC in previous troubles is displayed on Subaru Select Monitor display screen.
Second previous	The second latest DTC in previous troubles is displayed on Subaru Select Monitor display screen.
Third previous	The third latest DTC in previous problems is displayed on Subaru Select Monitor display screen.

Subaru Select Monitor

VEHICLE DYNAMICS CONTROL (VDC) (DIAGNOSTICS)

Brought to you by Eris Studios
NOT FOR RESALE

2. READ CURRENT DATA

- 1) On the «Main Menu» display, select {Each System Check}.
 - 2) On the «System Selection Menu», select {Brake Control}.
 - 3) Click the [OK] button after the {VDC} is displayed.
 - 4) On the «Brake Control Diagnosis» screen, select {Current Data Display & Save}.
 - 5) On the «Data Display Menu», select the data display method.
 - 6) Using the scroll key, scroll the display screen up or down until necessary data is shown.
- A list of the support data is shown in the following table.

Display	Contents to be monitored	Unit of measure
FR Wheel Speed	Wheel speed detected by front ABS wheel speed sensor RH is displayed.	km/h or MPH
FL Wheel Speed	Wheel speed detected by front ABS wheel speed sensor LH is displayed.	km/h or MPH
RR Wheel Speed	Wheel speed detected by rear ABS wheel speed sensor RH is displayed.	km/h or MPH
RL Wheel Speed	Wheel speed detected by rear ABS wheel speed sensor LH is displayed.	km/h or MPH
Steering Angle Sensor	Steering angle detected by steering angle sensor is displayed.	deg
Yaw Rate Sensor	Vehicle angular speed detected by yaw rate sensor is displayed.	deg/s
Pressure Sensor	Brake fluid pressure detected by pressure sensor is displayed.	bar
Lateral G Sensor	Vehicle lateral acceleration detected by lateral G sensor is displayed.	m/s (m/s ²)
IG power supply voltage	Voltage supplied to VDCCM&H/U is displayed.	V
E/G Control Prohibited Flag	Engine control command signal is displayed.	1 or 0
ABS Control Flag	ABS operation condition is displayed.	ON or OFF
EBD Control Flag	EBD operation condition is displayed.	ON or OFF
TCS Control Flag	TCS operation condition is displayed.	ON or OFF
VDC Control Flag	VDC operation condition is displayed.	ON or OFF
VDC OFF Light	ON/OFF condition of VDC OFF indicator light is displayed.	ON or OFF
EBD Warning Light	ON operation of the EBD warning light is displayed.	ON or OFF
ABS Warning Light	ON operation of the ABS warning light is displayed.	ON or OFF
VDC Warning Light	ON operation of the VDC warning light is displayed.	ON or OFF
Valve Relay Signal	Valve relay operation signal is displayed.	ON or OFF
Motor Relay Signal	Motor relay operation signal is displayed.	ON or OFF
Motor Relay Monitor	Voltage applied to the motor relay is displayed.	V
OFF Switch Signal	Operation condition of VDC OFF switch is displayed.	ON or OFF
Brake Switch	Brake ON/OFF is displayed.	ON or OFF
Fr Rr G sensor Output	Vehicle longitudinal acceleration detected by the longitudinal G sensor is displayed. (MT vehicles only. AT vehicles are fixed at -0.1 m/s ² .)	m/s ²
Clutch Switch	Clutch ON/OFF is displayed. (MT vehicles only. AT vehicles fixed at OFF.)	ON or OFF
Reverse Signal	Reverse gear ON/OFF is displayed. (MT vehicles only. AT vehicles fixed at OFF.)	ON or OFF

NOTE:

For details concerning the operation procedure, refer to the «help on PC application for Subaru Select Monitor».

3. CLEAR MEMORY MODE

- 1) On the «Main Menu», select {Each System Check}.
- 2) On the «System Selection Menu», select {Brake Control}.
- 3) Click the [OK] button after the {VDC} is displayed.
- 4) On the «Brake Control Diagnosis», select {Clear Memory}.
- 5) When the “Clear Memory?” is shown on the screen, click the [YES] button.
- 6) When “Done” and “Turn ignition switch to OFF” are shown on the display screen, turn the ignition switch to OFF.

NOTE:

For detailed operation procedure, refer to the «help on PC application for Subaru Select Monitor».

Subaru Select Monitor

VEHICLE DYNAMICS CONTROL (VDC) (DIAGNOSTICS)

Brought to you by Eriss Studios
NOT FOR SALE

4. FUNCTION CHECK

Display	Contents of display	Index No.
ABS sequence control	Operate the valve and pump motor continuously to perform the ABS sequence control.	<Ref. to ABS-10, ABS Sequence Control.>
VDC confirmation mode	Operate the valve and pump motor continuously to perform the VDC sequence control.	<Ref. to VDC-13, VDC Sequence Control.>
Set up mode for Neutral of Steering Angle Sensor & Lateral G Sensor 0 Point is not normal	Set the steering angle sensor neutral position and the lateral G sensor "0" point.	<Ref. to VDC-18, Steering Angle Sensor.>

5. FREEZE FRAME DATA

NOTE:

- Data stored at the time of trouble occurrence is shown on the display.
- Each time a trouble occurs, the latest information is stored in the freeze frame data in memory.
- If a freeze frame data is not properly stored in memory (due to a drop in VDCCM power supply, etc.), a DTC suffixed with a question mark "?" appears on the Subaru Select Monitor display. This shows it may be an unreliable reading.

Display	Contents to be monitored
Steering angle sensor	Steering angle detected by steering angle sensor is displayed.
Yaw rate sensor	Vehicle angular speed detected by yaw rate sensor is displayed.
Lateral G Sensor	Vehicle lateral acceleration detected by lateral G sensor is displayed.
Pressure Sensor	Brake fluid pressure detected by pressure sensor is displayed.
Vehicle Speed	Vehicle speed calculated by VDC control module is displayed.
FR Wheel Speed	Wheel speed detected by front ABS wheel speed sensor RH is displayed in km/h or MPH.
FL Wheel Speed	Wheel speed detected by front ABS wheel speed sensor LH is displayed in km/h or MPH.
RR Wheel Speed	Wheel speed detected by rear ABS wheel speed sensor RH is displayed in km/h or MPH.
RL Wheel Speed	Wheel speed detected by rear ABS wheel speed sensor LH is displayed in km/h or MPH.
Acceleration opening angle signal	Acceleration opening is displayed.
Engine Speed	Engine speed on malfunction occurrence is displayed.
Gear position	Gear position on malfunction occurrence is displayed.
IG power supply voltage	Voltage supplied to VDC control module is displayed.

Display	Contents to be monitored
Absolute angle recognition flag	Whether the absolute angle of the steering angle sensor was determined is displayed.
EAM signal	Engine control command signal is displayed.
VDC Control Flag	VDC control condition is displayed.
EBD Control Flag	EBD control condition is displayed.
TCS Control Flag	TCS control condition is displayed.
ABS Control Flag	ABS control condition is displayed.
VDC OFF light	ON/OFF condition of the VDC operated by the driver is displayed.
Brake Switch	Brake ON/OFF is displayed.
Fr Rr G sensor Output	Vehicle longitudinal acceleration detected by the longitudinal G sensor is displayed. (MT vehicles only. AT vehicles are fixed at -0.1 m/s^2 .)
Clutch Switch	Clutch ON/OFF is displayed. (MT vehicles only. AT vehicles fixed at OFF.)
Reverse Signal	Reverse gear ON/OFF is displayed. (MT vehicles only. AT vehicles fixed at OFF.)

6. PARAMETER SELECTION

CAUTION:

- **Subaru Select Monitor is required for parameter selection.**
- **This function can be used for the replacement VDCCM&H/U and VDCCM.**

NOTE:

- When a VDCCM is replaced with a replacement, use this function to select and register parameters to the VDCCM.
 - For confirmation of applied models, refer to the “Model number plate” attached to the vehicles. <Ref. to ID-2, IDENTIFICATION, Identification.>
 - If a wrong applied model is written, it can be rewritten.
 - When no data is registered, ABS/EBD/VDC warning light illuminates and the DTC “Parameter selection failure” is detected.
- 1) Connect the Subaru Select Monitor.
 - 2) On the «Main Menu» display, select {Each System Check}.
 - 3) On the «System Selection Menu», select {Brake Control}.
 - 4) Click the [OK] button after the {VDC} is displayed.
 - 5) On the «Brake Control Diagnosis», select {Parameter Selection}.
 - 6) Check the applied model indicated in the “Model number plate”. <Ref. to ID-2, IDENTIFICATION, Identification.>
 - 7) Enter the applied model of 7-digit alphanumeric characters and press the [Enter] key.
 - 8) When the confirmation screen indicating the vehicle information appears, check that the correct applied model and grade are displayed and click the [OK] button.

NOTE:

- When the displayed applied model and grade are different from those of the vehicle, perform registration operations again after clicking the [OK] button.
- 9) Execute Clear Memory after parameter selection and registration operations because the DTC for “Parameter selection failure” is memorized.

7. PARAMETER CHECK

NOTE:

The parameter data registered in the VDCCM is shown on the display.

- 1) Connect the Subaru Select Monitor.
- 2) On the «Main Menu» display, select {Each System Check}.
- 3) On the «System Selection Menu», select {Brake Control}.
- 4) Click the [OK] button after the {VDC} is displayed.
- 5) On the «Brake Control Diagnosis», select {Parameter Check}.
- 6) On the {Parameter Check} display screen, check that the applied model and grade of the target vehicle are included, and click the [OK] button.
- 7) If the applied model and grade of the target vehicle are not included on the {Parameter Check} display screen, perform parameter selection and registration. <Ref. to VDC(diag)-18, PARAMETER SELECTION, OPERATION, Subaru Select Monitor.>

Subaru Select Monitor

VEHICLE DYNAMICS CONTROL (VDC) (DIAGNOSTICS)

Brought to you by Eris Studios
NOT FOR SALE

B: INSPECTION

1. COMMUNICATION FOR INITIALIZING IMPOSSIBLE

DETECTING CONDITION:

Defective harness connector

TROUBLE SYMPTOM:

Communication is impossible between VDC and Subaru Select Monitor.

WIRING DIAGRAM:

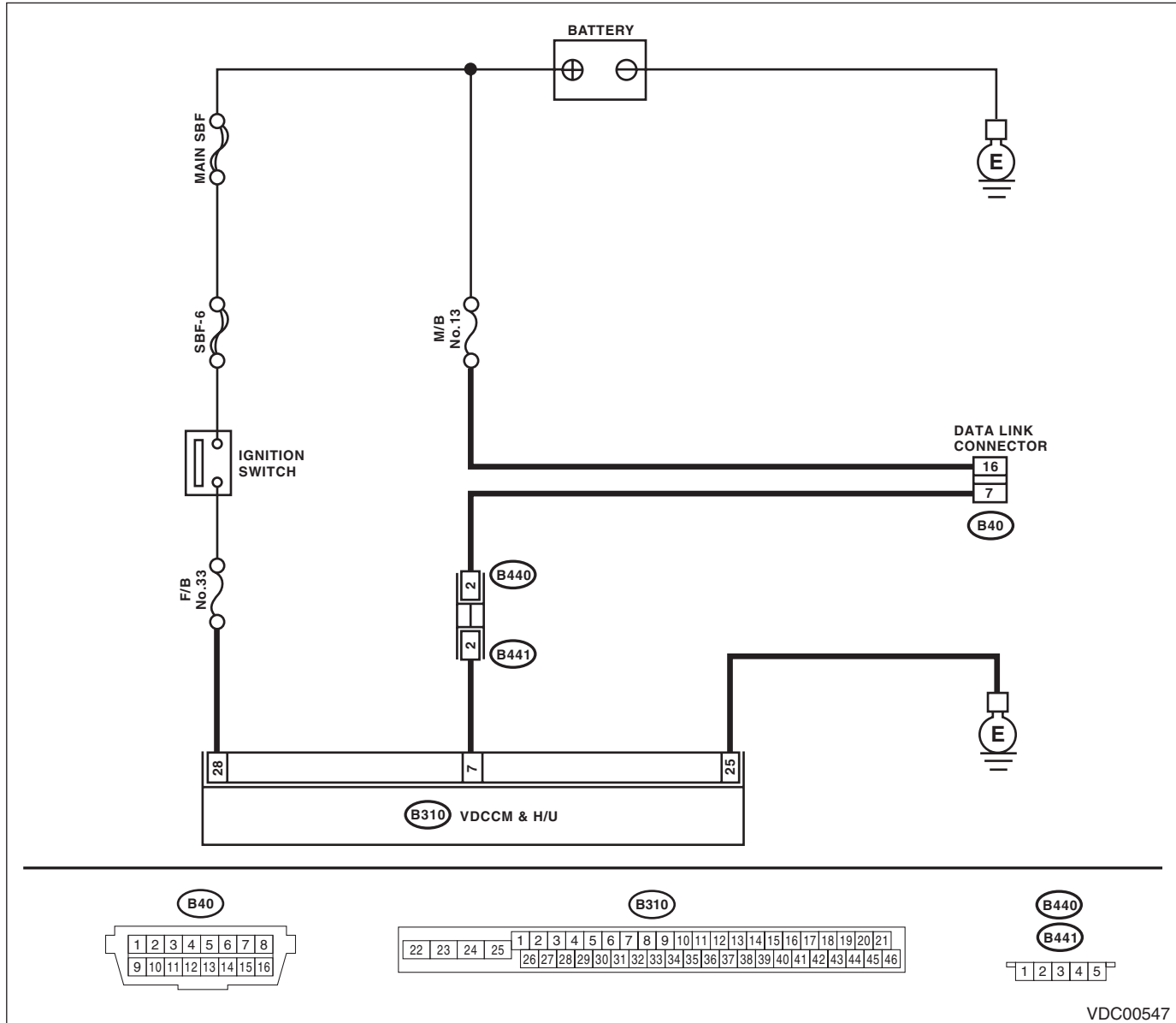

Subaru Select Monitor

VEHICLE DYNAMICS CONTROL (VDC) (DIAGNOSTICS)

Brought to you by Eris Studios
NOT FOR RESALE

	Step	Check	Yes	No
1	CHECK IGNITION SWITCH.	Is the ignition switch ON?	Go to step 2.	Turn the ignition switch to ON, and select VDC mode using Subaru Select Monitor.
2	CHECK BATTERY. 1) Turn the ignition switch to OFF. 2) Measure the battery voltage.	Is the voltage 11 V or more?	Go to step 3.	Charge or replace the battery.
3	CHECK BATTERY TERMINAL.	Is there poor contact at the battery terminal?	Repair or tighten the battery terminal.	Go to step 4.
4	CHECK SUBARU SELECT MONITOR COMMUNICATION. 1) Turn the ignition switch to ON. 2) Using the Subaru Select Monitor, check whether communication to other systems can be performed normally.	Is the system name displayed on the Subaru Select Monitor?	Go to step 8.	Go to step 5.
5	CHECK SUBARU SELECT MONITOR COMMUNICATION. 1) Turn the ignition switch to OFF. 2) Disconnect the VDCCM&H/U connector. 3) Turn the ignition switch to ON. 4) Check whether communication to other systems can be executed normally.	Is the system name displayed on Subaru Select Monitor?	Replace the VDCCM only. <Ref. to VDC-10, REPLACEMENT, VDC Control Module and Hydraulic Control Unit (VDCCM&H/U).>	Go to step 6.
6	CHECK HARNESS CONNECTOR BETWEEN EACH CONTROL MODULE AND DATA LINK CONNECTOR. 1) Turn the ignition switch to OFF. 2) Disconnect the VDCCM&H/U, ECM and TCM. 3) Measure the resistance between data link connector and chassis ground. Connector & terminal (B40) No. 7 — Chassis ground:	Is the resistance 1 MΩ or more?	Go to step 7.	Repair the harness and connector between each control module and data link connector.
7	CHECK OUTPUT SIGNAL FOR VDCCM&H/U. 1) Turn the ignition switch to ON. 2) Measure the voltage between data link connector and chassis ground. Connector & terminal (B40) No. 7 (+) — Chassis ground (-):	Is the voltage less than 1 V?	Go to step 8.	Repair the harness and connector between each control module and data link connector.
8	CHECK THE HARNESS CONNECTOR BETWEEN VDCCM&H/U AND DATA LINK CONNECTOR. Measure the resistance between VDCCM&H/U connector and data link connector. Connector & terminal (B310) No. 7 — (B40) No. 7:	Is the resistance less than 0.5 Ω?	Go to step 9.	Repair harness and connector between VDCCM&H/U and data link connector.
9	CHECK INSTALLATION OF VDCCM&H/U CONNECTOR. Turn the ignition switch to OFF.	Is the VDCCM&H/U connector inserted into VDCCM&H/U until the clamp locks onto it?	Go to step 10.	Insert VDCCM&H/U connector into VDCCM&H/U.
10	CHECK POWER SUPPLY CIRCUIT. 1) Turn the ignition switch to ON. (engine OFF) 2) Measure the ignition power supply voltage between VDCCM&H/U connector and chassis ground. Connector & terminal (B310) No. 28 (+) — Chassis ground (-):	Is the voltage 10 — 15 V?	Go to step 11.	Repair open circuit in harness between VDCCM&H/U and battery.

Subaru Select Monitor

VEHICLE DYNAMICS CONTROL (VDC) (DIAGNOSTICS)

Brought to you by Eris Studios
 NOT FOR SALE

Step	Check	Yes	No
11 CHECK THE HARNESS CONNECTOR BETWEEN VDCCM&H/U AND CHASSIS GROUND. 1) Turn the ignition switch to OFF. 2) Disconnect the connector from the VDCCM&H/U. 3) Measure the resistance of harness between VDCCM&H/U connector and chassis ground. Connector & terminal (B310) No. 25 — Chassis ground:	Is the resistance less than 0.5 Ω?	Go to step 12.	Repair the open circuit of VDCCM&H/U ground harness and poor contact of connector.
12 CHECK POOR CONTACT IN CONNECTOR.	Is there poor contact in control module power supply, ground circuit and data link connector?	Repair the connector.	Replace the VDCCM only. <Ref. to VDC-10, REPLACEMENT, VDC Control Module and Hydraulic Control Unit (VDCCM&H/U).>

Read Diagnostic Trouble Code (DTC)

VEHICLE DYNAMICS CONTROL (VDC) (DIAGNOSTICS)

7. Read Diagnostic Trouble Code (DTC)

A: OPERATION

For details concerning DTC reading procedure, refer to "Subaru Select Monitor". <Ref. to VDC(diag)-15, Subaru Select Monitor.>

Brought to you by Eris Studios
NOT FOR RESALE

8. Inspection Mode

A: PROCEDURE

Reproduce the malfunction occurrence condition as much as possible.

Drive the vehicle at least ten minutes.

NOTE:

Make sure the vehicle is not dragged to one side under usual driving condition.

Clear Memory Mode

VEHICLE DYNAMICS CONTROL (VDC) (DIAGNOSTICS)

9. Clear Memory Mode

A: OPERATION

For details concerning DTC clear operation, refer to "Subaru Select Monitor". <Ref. to VDC(diag)-15, Subaru Select Monitor.>

Brought to you by Eris Studios
NOT FOR RESALE

Warning Light Illumination Pattern

VEHICLE DYNAMICS CONTROL (VDC) (DIAGNOSTICS)

Brought to you by Eris Studios
NOT FOR SALE

10.Warning Light Illumination Pattern

A: INSPECTION

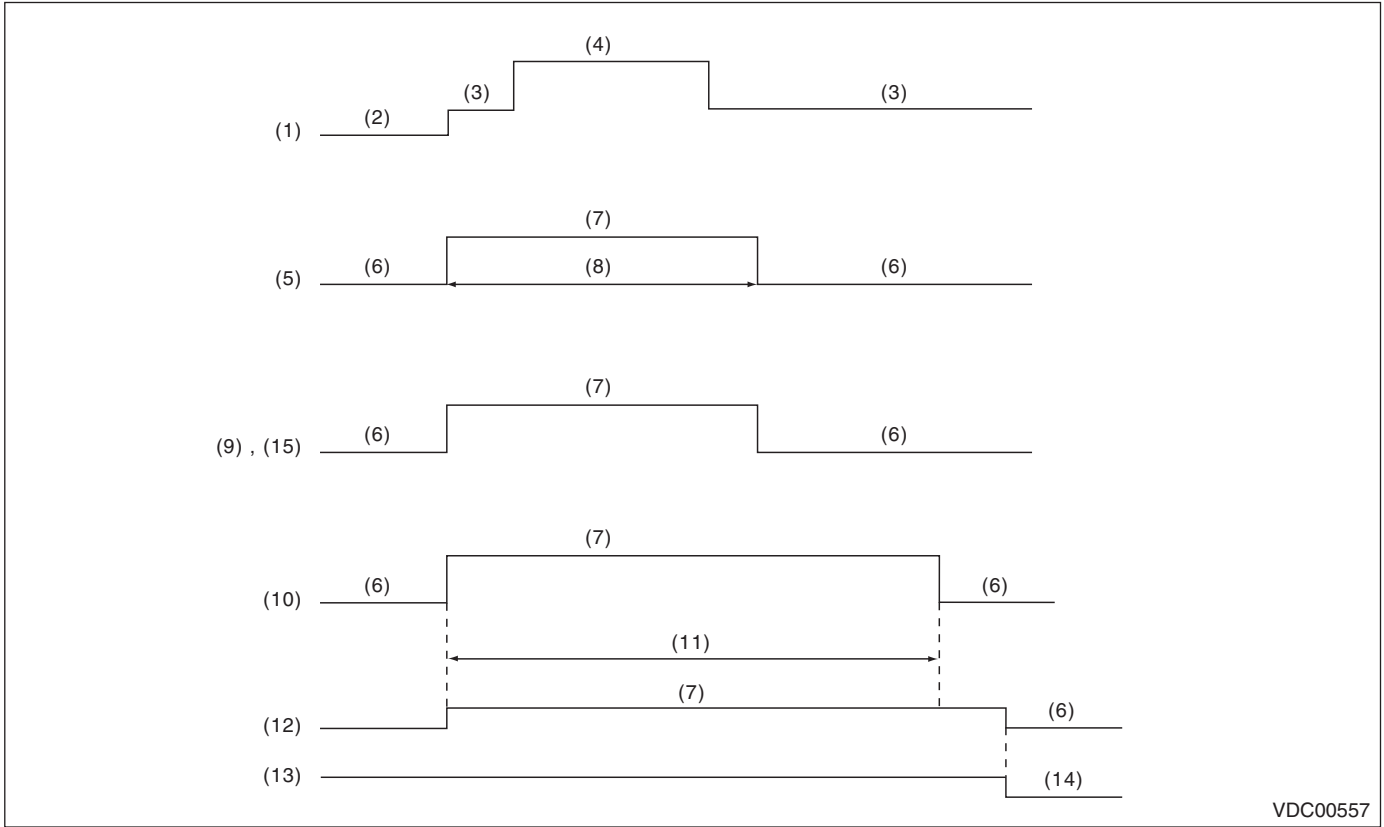

VDC00557

- | | | |
|-----------------------|--|--|
| (1) Ignition switch | (8) 2 sec. | (12) Brake warning light (EBD warning light) |
| (2) OFF | (9) VDC indicator light | (13) Parking brake |
| (3) ON | (10) VDC warning light and VDC OFF indicator light | (14) Released |
| (4) Engine start | (11) Several seconds (depending on engine coolant temperature) | (15) Hill start assist warning light |
| (5) ABS warning light | | |
| (6) Light OFF | | |
| (7) Light ON | | |

Warning Light Illumination Pattern

VEHICLE DYNAMICS CONTROL (VDC) (DIAGNOSTICS)

Brought to you by Eris Studios
NOT FOR RESALE

1) When warning lights or indicator lights do not illuminate in accordance with this illumination pattern, there must be an electrical malfunction.

2) When warning lights or indicator lights remain constantly OFF, check the combination meter circuit or CAN communication circuit. <Ref. to VDC(diag)-27, VDC WARNING LIGHT, VDC OFF INDICATOR LIGHT AND VDC INDICATOR LIGHT DO NOT COME ON, Warning Light Illumination Pattern.>

3) When the ABS warning light and the hill start assist warning light do not go off, check the combination meter circuit. <Ref. to VDC(diag)-28, ABS WARNING LIGHT DOES NOT GO OFF, Warning Light Illumination Pattern.>

4) When the VDC indicator light, VDC warning light and VDC OFF indicator light do not go off, check the combination meter circuit or CAN communication circuit. <Ref. to VDC(diag)-28, VDC INDICATOR LIGHT DOES NOT GO OFF, Warning Light Illumination Pattern.>

NOTE:

- Even though the ABS warning light does not go off after 2 seconds from ABS warning light illumination, the ABS system operates normally when the warning light goes off while driving at approximately 12 km/h (7 MPH). However, the ABS system does not work while the ABS warning light is illuminated.
- It may take several minutes before VDC warning light and VDC OFF indicator light goes off if the vehicle is parked under low temperature for a specified time. This is not defective because it is resulted from low engine coolant temperature.
- With the vehicle jack-up/lift up or set on free rollers, when the wheels lock or spin after starting the engine, ABS warning light, VDC warning light and VDC OFF indicator light may illuminate because VDCCM&H/U detects the abnormal conditions from ABS wheel speed sensors. In this case, this is not a malfunction. Perform the Clear Memory Mode.

Warning Light Illumination Pattern

VEHICLE DYNAMICS CONTROL (VDC) (DIAGNOSTICS)

Brought to you by Eris Studios
NOT FOR SALE

B: VDC WARNING LIGHT, VDC OFF INDICATOR LIGHT AND VDC INDICATOR LIGHT DO NOT COME ON

DETECTING CONDITION:

- Defective combination meter
- Defective CAN communication

TROUBLE SYMPTOM:

When the ignition switch is turned to ON (engine OFF), VDC indicator light, VDC warning light and VDC OFF indicator light do not come on.

NOTE:

When pressing the VDC OFF switch for 10 seconds or more, the VDC OFF indicator light goes off and cannot operate any more. When turning the ignition switch from OFF to ON, the OFF operation enabled status is restored.

	Step	Check	Yes	No
1	CHECK OTHER INDICATOR LIGHT. Turn the ignition switch to ON.	Does other indicator light illuminate soon after "ON"?	Go to step 2.	Perform the self-diagnosis of combination meter.
2	CHECK VDCCM. When the engine does not start, display the current data of VDCCM using Subaru Select Monitor.	Is "VDC warning light" output set to "ON"?	Go to step 3.	Replace the VDCCM only.
3	CHECK LAN SYSTEM. Perform the diagnosis for LAN system. <Ref. to LAN(diag)-29, OPERATION, Read Diagnostic Trouble Code (DTC).>	Is there any fault in LAN system?	Perform the diagnosis according to DTC for LAN system.	Go to step 4.
4	CHECK COMBINATION METER. Check the combination meter.	Is combination meter OK?	Replace the VDCCM only.	Repair the combination meter assembly.

C: ABS WARNING LIGHT DOES NOT COME ON

DETECTING CONDITION:

- Defective combination meter
- Defective CAN communication

Trouble symptom:

When the ignition switch is turned to ON (engine OFF), the ABS warning light and hill start assist warning light do not come on.

	Step	Check	Yes	No
1	CHECK OTHER LIGHTS TURN ON. Turn the ignition switch to ON. (engine OFF)	Do other warning lights illuminate?	Go to step 2.	Check the combination meter.
2	READ DTC. Read the DTC. <Ref. to VDC(diag)-22, Read Diagnostic Trouble Code (DTC).>	Is DTC displayed?	Perform the diagnosis according to DTC.	Go to step 3.
3	CHECK LAN SYSTEM. Perform the diagnosis for LAN system. <Ref. to LAN(diag)-29, OPERATION, Read Diagnostic Trouble Code (DTC).>	Is there any fault in LAN system?	Perform the diagnosis according to DTC for LAN system.	Go to step 4.
4	CHECK COMBINATION METER. Check the combination meter.	Is combination meter OK?	Replace the VDCCM only.	Repair the combination meter assembly.

Warning Light Illumination Pattern

VEHICLE DYNAMICS CONTROL (VDC) (DIAGNOSTICS)

Brought to you by Eris Studios
NOT FOR RESALE

D: ABS WARNING LIGHT DOES NOT GO OFF

DETECTING CONDITION:

- Defective combination meter
- Defective CAN communication

TROUBLE SYMPTOM:

When starting the engine, the ABS warning light and hill start assist warning light remains lit.

	Step	Check	Yes	No
1	READ DTC. Read the DTC. <Ref. to VDC(diag)-22, Read Diagnostic Trouble Code (DTC).>	Is DTC displayed?	Perform the diagnosis according to DTC.	Go to step 2.
2	CHECK LAN SYSTEM. Perform the diagnosis for LAN system. <Ref. to LAN(diag)-29, OPERATION, Read Diagnostic Trouble Code (DTC).>	Is there any fault in LAN system?	Perform the diagnosis according to DTC for LAN system.	Go to step 3.
3	CHECK COMBINATION METER. Check the combination meter.	Is combination meter OK?	Replace the VDCCM only.	Repair the combination meter.

E: VDC INDICATOR LIGHT DOES NOT GO OFF

DETECTING CONDITION:

- Defective combination meter
- Defective CAN communication

TROUBLE SYMPTOM:

When starting the engine, VDC indicator light is kept ON.

	Step	Check	Yes	No
1	READ DTC. Read the DTC. <Ref. to VDC(diag)-22, Read Diagnostic Trouble Code (DTC).>	Is DTC displayed?	Perform the diagnosis according to DTC.	Go to step 2.
2	CHECK LAN SYSTEM. Perform the diagnosis for LAN system. <Ref. to LAN(diag)-29, OPERATION, Read Diagnostic Trouble Code (DTC).>	Is there any fault in LAN system?	Perform the diagnosis according to DTC for LAN system.	Go to step 3.
3	CHECK COMBINATION METER. Check the combination meter.	Is combination meter OK?	Replace the VDCCM only.	Repair the combination meter.

Warning Light Illumination Pattern

VEHICLE DYNAMICS CONTROL (VDC) (DIAGNOSTICS)

Brought to you by Eris Studios
NOT FOR SALE

F: VDC WARNING LIGHT AND VDC OFF INDICATOR LIGHT DO NOT GO OFF

DETECTING CONDITION:

- Defective combination meter
- Defective CAN communication
- Defective engine
- VDC OFF switch is shorted.

TROUBLE SYMPTOM:

When starting the engine, VDC OFF indicator light is kept ON.

NOTE:

When pressing the VDC OFF switch for 10 seconds or more, the VDC OFF indicator light goes off and cannot operate any more. When turning the ignition switch from OFF to ON, the OFF operation enabled status is restored.

	Step	Check	Yes	No
1	READ DTC. Read the DTC. <Ref. to VDC(diag)-22, Read Diagnostic Trouble Code (DTC).>	Is DTC displayed?	Perform the diagnosis according to DTC.	Go to step 2.
2	CHECK ENGINE.	Does the malfunction indicator light illuminate?	Repair the engine.	Go to step 3.
3	CHECK ENGINE COOLANT TEMPERATURE. Warm up the engine and check if VDC warning light and VDC OFF indicator light illumination condition changes.	When the engine coolant temperature is too low, VDC warning light and VDC OFF indicator light illuminate. Do the lights go off when the engine is warmed-up?	Normal operation	Go to step 4.
4	CHECK VDC OFF SWITCH. Remove and check VDC OFF switch.	Is the VDC OFF switch normal?	Go to step 5.	Replace the VDC OFF switch.
5	CHECK LAN SYSTEM. Perform the diagnosis for LAN system. <Ref. to LAN(diag)-29, OPERATION, Read Diagnostic Trouble Code (DTC).>	Is there any fault in LAN system?	Perform the diagnosis according to DTC for LAN system.	Go to step 6.
6	CHECK COMBINATION METER. Check the combination meter.	Is combination meter OK?	Replace the VDCCM only.	Repair the combination meter.

Warning Light Illumination Pattern

VEHICLE DYNAMICS CONTROL (VDC) (DIAGNOSTICS)

Brought to you by Eris Studios
NOT FOR SALE

Step	Check	Yes	No
1 CHECK INSTALLATION OF VDCCM&H/U CONNECTOR. 1) Turn the ignition switch to OFF. 2) Check that the VDCCM&H/U connector is inserted until it is locked by clamp.	Is the connector firmly inserted?	Go to step 2.	Insert the VDCCM&H/U connector until it is locked by clamp.
2 READ DTC. Read the DTC. <Ref. to VDC(diag)-22, Read Diagnostic Trouble Code (DTC).>	Is DTC displayed?	Perform the diagnosis according to DTC.	Go to step 3.
3 CHECK BRAKE FLUID AMOUNT. Check the amount of brake fluid in the reservoir tank of master cylinder.	Is the amount of brake fluid between the lines of "MAX" and "MIN"?	Go to step 4.	Replenish brake fluid to the specified value.
4 CHECK BRAKE FLUID LEVEL SWITCH. 1) Turn the ignition switch to OFF. 2) Disconnect the level switch connector (B16) from master cylinder. 3) Measure the resistance of master cylinder terminals. <i>Terminals</i> <i>No. 1 — No. 2:</i>	Is the resistance 1 MΩ or more?	Go to step 5.	Replace the master cylinder.
5 CHECK GROUND SHORT OF HARNESS. 1) Disconnect the connectors (i10) and (i11) from the combination meter. 2) Measure the resistance between combination meter connector and chassis ground. <i>Connector & terminal</i> <i>(i10) No. 8 — Chassis ground:</i>	Is the resistance 1 MΩ or more?	Go to step 6.	Repair the harness connector between the combination meter and brake fluid level switch.
6 CHECK PARKING BRAKE SWITCH. 1) Disconnect the connector (R4) from parking brake switch. 2) Release the parking brake. 3) Measure the resistance between parking brake switch terminal and chassis ground.	Is the resistance 1 MΩ or more?	Go to step 7.	Replace the parking brake switch.
7 CHECK GROUND SHORT OF HARNESS. 1) Disconnect the connector (B281) from body integrated unit. 2) Measure the resistance between body integrated unit connector and chassis ground. <i>Connector & terminal</i> <i>(B281) No. 15 — Chassis ground:</i>	Is the resistance 1 MΩ or more?	Go to step 8.	Repair the harness between the body integrated unit and parking brake switch.
8 CHECK POOR CONTACT IN CONNECTOR. Check for poor contact in all connectors.	Is there poor contact?	Repair the connector.	Go to step 9.
9 CHECK LAN SYSTEM. Perform the diagnosis for LAN system. <Ref. to LAN(diag)-29, OPERATION, Read Diagnostic Trouble Code (DTC).>	Is there any fault in LAN system?	Perform the diagnosis according to DTC for LAN system.	Go to step 10.
10 CHECK COMBINATION METER. Check the combination meter.	Is combination meter OK?	Replace the VDCCM only.	Repair the combination meter.

List of Diagnostic Trouble Code (DTC)

VEHICLE DYNAMICS CONTROL (VDC) (DIAGNOSTICS)

Brought to you by Eris Studios
NOT FOR RESALE

11. List of Diagnostic Trouble Code (DTC)

A: LIST

DTC	Detailed code	Display	Content of diagnosis	Reference target
C0021	07B1H 07B2H 07C0H	Front Right ABS Sensor Circuit Open or Shorted Battery	Open/high input of front ABS wheel speed sensor RH	<Ref. to VDC(diag)-38, DTC C0021 FRONT RIGHT ABS SENSOR CIRCUIT OPEN OR SHORT, Diagnostic Procedure with Diagnostic Trouble Code (DTC).>
C0022	0720H 072FH 0736H 0737H 0738H 073AH 073CH	Front Right ABS Sensor Signal	Front ABS wheel speed sensor RH signal malfunction	<Ref. to VDC(diag)-41, DTC C0022 FRONT RIGHT ABS SENSOR SIGNAL, Diagnostic Procedure with Diagnostic Trouble Code (DTC).>
C0023	06B1H 06B2H 06C0H	Front Left ABS Sensor Circuit Open or Shorted Battery	Open/high input of front ABS wheel speed sensor LH	<Ref. to VDC(diag)-38, DTC C0023 FRONT LEFT ABS SENSOR CIRCUIT OPEN OR SHORT, Diagnostic Procedure with Diagnostic Trouble Code (DTC).>
C0024	0620H 062FH 0636H 0637H 0638H 063AH 063CH	Front Left ABS Sensor Signal	Front ABS wheel speed sensor LH signal malfunction	<Ref. to VDC(diag)-41, DTC C0024 FRONT LEFT ABS SENSOR SIGNAL, Diagnostic Procedure with Diagnostic Trouble Code (DTC).>
C0025	09B1H 09B2H 09C0H	Rear Right ABS Sensor Circuit Open or Shorted Battery	Open/high input of rear ABS wheel speed sensor RH	<Ref. to VDC(diag)-38, DTC C0025 REAR RIGHT ABS SENSOR CIRCUIT OPEN OR SHORT, Diagnostic Procedure with Diagnostic Trouble Code (DTC).>
C0026	0920H 092FH 0936H 0937H 0938H 093AH 093CH	Rear Right ABS Sensor Signal	Rear ABS wheel speed sensor RH signal malfunction	<Ref. to VDC(diag)-41, DTC C0026 REAR RIGHT ABS SENSOR SIGNAL, Diagnostic Procedure with Diagnostic Trouble Code (DTC).>
C0027	08B1H 08B2H 08C0H	Rear Left ABS Sensor Circuit Open or Shorted Battery	Open/high input of rear ABS wheel speed sensor LH	<Ref. to VDC(diag)-39, DTC C0027 REAR LEFT ABS SENSOR CIRCUIT OPEN OR SHORT, Diagnostic Procedure with Diagnostic Trouble Code (DTC).>
C0028	0820H 082FH 0836H 0837H 0838H 083AH 083CH	Rear Left ABS Sensor Signal	Rear ABS wheel speed sensor LH signal malfunction	<Ref. to VDC(diag)-42, DTC C0028 REAR LEFT ABS SENSOR SIGNAL, Diagnostic Procedure with Diagnostic Trouble Code (DTC).>
C0029	0A10H 0A41H 0A4BH 0A4DH 0A52H 0A56H 0A60H	Any One of Four ABS Sensors Signal	ABS wheel speed sensor signal malfunction in one of four wheels	<Ref. to VDC(diag)-45, DTC C0029 ANY OF WHEEL SENSORS SIGNAL, Diagnostic Procedure with Diagnostic Trouble Code (DTC).>

List of Diagnostic Trouble Code (DTC)

VEHICLE DYNAMICS CONTROL (VDC) (DIAGNOSTICS)

Brought to you by Eris Studios
NOT FOR SALE

DTC	Detailed code	Display	Content of diagnosis	Reference target
C0031	0DB8H 0DC0H 0DC1H 0DD0H	FR hold valve malfunction	Front inlet solenoid valve RH malfunction in VDCCM&H/U	<Ref. to VDC(diag)-47, DTC C0031 FR HOLD VALVE MALFUNCTION, Diagnostic Procedure with Diagnostic Trouble Code (DTC).>
C0032	0EB8H 0EC0H 0EC1H 0ED0H	FR pressure reducing valve malfunction	Front outlet solenoid valve RH malfunction in VDCCM&H/U	<Ref. to VDC(diag)-47, DTC C0032 FR PRESSURE REDUCING VALVE MALFUNCTION, Diagnostic Procedure with Diagnostic Trouble Code (DTC).>
C0033	0BB8H 0BC0H 0BC1H 0BD0H	FL hold valve malfunction	Front inlet solenoid valve LH malfunction in VDCCM&H/U	<Ref. to VDC(diag)-47, DTC C0033 FL HOLD VALVE MALFUNCTION, Diagnostic Procedure with Diagnostic Trouble Code (DTC).>
C0034	0CB8H 0CC0H 0CC1H 0CD0H	FL pressure reducing valve malfunction	Front outlet solenoid valve LH malfunction in VDCCM&H/U	<Ref. to VDC(diag)-47, DTC C0034 FL PRESSURE REDUCING VALVE MALFUNCTION, Diagnostic Procedure with Diagnostic Trouble Code (DTC).>
C0035	11B8H 11C0H 11C1H 11D0H	RR hold valve malfunction	Rear inlet solenoid valve RH malfunction in VDCCM&H/U	<Ref. to VDC(diag)-47, DTC C0035 RR HOLD VALVE MALFUNCTION, Diagnostic Procedure with Diagnostic Trouble Code (DTC).>
C0036	12B8H 12C0H 12C1H 12D0H	RR pressure reducing valve malfunction	Rear outlet solenoid valve RH malfunction in VDCCM&H/U	<Ref. to VDC(diag)-47, DTC C0036 RR PRESSURE REDUCING VALVE MALFUNCTION, Diagnostic Procedure with Diagnostic Trouble Code (DTC).>
C0037	0FB8H 0FC0H 0FC1H 0FD0H	RL hold valve malfunction	Rear inlet solenoid valve LH malfunction in VDCCM&H/U	<Ref. to VDC(diag)-48, DTC C0037 RL HOLD VALVE MALFUNCTION, Diagnostic Procedure with Diagnostic Trouble Code (DTC).>
C0038	10B8H 10C0H 10C1H 10D0H	RL pressure reducing valve malfunction	Rear outlet solenoid valve LH malfunction in VDCCM&H/U	<Ref. to VDC(diag)-48, DTC C0038 RL PRESSURE REDUCING VALVE MALFUNCTION, Diagnostic Procedure with Diagnostic Trouble Code (DTC).>
C0039	0FB5H 11B5H	Any one of four solenoid valves	Solenoid valve malfunction in one of four wheels	<Ref. to VDC(diag)-48, DTC C0039 ANY ONE OF FOUR SOLENOID VALVES, Diagnostic Procedure with Diagnostic Trouble Code (DTC).>
C0041	—	ECM	VDC control module malfunction	<Ref. to VDC(diag)-51, DTC C0041 ECM, Diagnostic Procedure with Diagnostic Trouble Code (DTC).>
	1630H 1645H 16C0H	Parameter selection error	VDC control module parameter selection failure	<Ref. to VDC(diag)-53, DTC C0041 PARAMETER SELECTION ERROR, Diagnostic Procedure with Diagnostic Trouble Code (DTC).>
C0042	0316H 031CH 0322H 0324H	Power Supply Voltage Failure	Power voltage malfunction	<Ref. to VDC(diag)-54, DTC C0042 POWER SUPPLY VOLTAGE FAILURE, Diagnostic Procedure with Diagnostic Trouble Code (DTC).>
C0044	2921H	TCM communication circuit	CAN communication failure of transmission control module	<Ref. to VDC(diag)-56, DTC C0044 TCM COMMUNICATION CIRCUIT, Diagnostic Procedure with Diagnostic Trouble Code (DTC).>
C0045	2922H 2932H	Incorrect VDC Control Module specifications	Different VDC control module specification	<Ref. to VDC(diag)-57, DTC C0045 INCORRECT VDC CONTROL MODULE SPECIFICATIONS, Diagnostic Procedure with Diagnostic Trouble Code (DTC).>
	2923H	TCM malfunction	AT control module malfunction	<Ref. to VDC(diag)-58, DTC C0045 TCM MALFUNCTION, Diagnostic Procedure with Diagnostic Trouble Code (DTC).>

List of Diagnostic Trouble Code (DTC)

VEHICLE DYNAMICS CONTROL (VDC) (DIAGNOSTICS)

Brought to you by Eris Studios
NOT FOR RESALE

DTC	Detailed code	Display	Content of diagnosis	Reference target
C0047	1504H	Improper CAN Communication	Improper CAN communication	<Ref. to VDC(diag)-59, DTC C0047 CAN COMMUNICATION, Diagnostic Procedure with Diagnostic Trouble Code (DTC).>
	1505H			
	1506H			
	1507H			
	1508H			
	150EH			
	1512H			
	1514H			
	1518H			
	1519H			
	151AH			
	151DH			
	151EH			
	151FH			
1520H				
1531H				
1540H				
15C0H				
C0051	021FH	Valve Relay	Valve Relay	<Ref. to VDC(diag)-61, DTC C0051 VALVE RELAY, Diagnostic Procedure with Diagnostic Trouble Code (DTC).>
	0220H			
	0221H			
	0280H			
	0281H			
	02B0H			
	02B1H			
02C0H				
C0052	0562H	Motor and motor relay OFF failure	Motor/motor relay OFF malfunction	<Ref. to VDC(diag)-63, DTC C0052 MOTOR AND MOTOR RELAY OFF FAILURE, Diagnostic Procedure with Diagnostic Trouble Code (DTC).>
	0574H	Motor and motor relay ON failure	Motor/motor relay ON malfunction	<Ref. to VDC(diag)-65, DTC C0052 MOTOR AND MOTOR RELAY ON FAILURE, Diagnostic Procedure with Diagnostic Trouble Code (DTC).>
	0580H			
	05A0H			
	0560H	Motor malfunction	Motor	<Ref. to VDC(diag)-66, DTC C0052 MOTOR MALFUNCTION, Diagnostic Procedure with Diagnostic Trouble Code (DTC).>
C0054	04B0H	Brake Light Switch	BLS open circuit	<Ref. to VDC(diag)-67, DTC C0054 BLS CIRCUIT OPEN, Diagnostic Procedure with Diagnostic Trouble Code (DTC).>
	043CH	BLS ON Malfunction	BLS ON malfunction	<Ref. to VDC(diag)-69, DTC C0054 BLS ON MALFUNCTION, Diagnostic Procedure with Diagnostic Trouble Code (DTC).>
	04C1H	BLS OFF Malfunction	BLS OFF malfunction	<Ref. to VDC(diag)-71, DTC C0054 BLS OFF MALFUNCTION, Diagnostic Procedure with Diagnostic Trouble Code (DTC).>
C0056	1760H 1770H 1780H	G Sensor Signal	Abnormal longitudinal G sensor output signal	<Ref. to VDC(diag)-73, DTC C0056 G SENSOR SIGNAL, Diagnostic Procedure with Diagnostic Trouble Code (DTC).>
C0057	2931H	ECM communication circuit	CAN communication failure of engine control module	<Ref. to VDC(diag)-75, DTC C0057 ECM COMMUNICATION CIRCUIT, Diagnostic Procedure with Diagnostic Trouble Code (DTC).>
	2930H	ECM control system	Coordinate control prohibition of engine control module	<Ref. to VDC(diag)-76, DTC C0057 ECM CONTROL SYSTEM, Diagnostic Procedure with Diagnostic Trouble Code (DTC).>
C0061	19B8H 19C0H 19C1H 19D0H	Normal Opening Valve 1 malfunction	Secondary cut valve malfunction in VDCCM&H/U	<Ref. to VDC(diag)-48, DTC C0061 NORMAL OPENING VALVE 1 MALFUNCTION, Diagnostic Procedure with Diagnostic Trouble Code (DTC).>

List of Diagnostic Trouble Code (DTC)

VEHICLE DYNAMICS CONTROL (VDC) (DIAGNOSTICS)

Brought to you by Eris Studios
NOT FOR RESALE

DTC	Detailed code	Display	Content of diagnosis	Reference target
C0062	1AB8H 1AC0H 1AC1H 1AD0H	Normal Opening Valve 2 malfunction	Primary cut valve malfunction in VDCCM&H/U	<Ref. to VDC(diag)-48, DTC C0062 NORMAL OPENING VALVE 2 MALFUNCTION, Diagnostic Procedure with Diagnostic Trouble Code (DTC).>
C0063	1BB8H 1BC0H 1BC1H 1BD0H	Normal Closing Valve 1 malfunction	Secondary suction valve malfunction in VDCCM&H/U	<Ref. to VDC(diag)-48, DTC C0063 NORMAL CLOSING VALVE 1 MALFUNCTION, Diagnostic Procedure with Diagnostic Trouble Code (DTC).>
C0064	1CB8H 1CC0H 1CC1H 1CD0H	Normal Closing Valve 2 malfunction	Primary suction valve malfunction in VDCCM&H/U	<Ref. to VDC(diag)-49, DTC C0064 NORMAL CLOSING VALVE 2 MALFUNCTION, Diagnostic Procedure with Diagnostic Trouble Code (DTC).>
C0071	2130H	Steering angle sensor offset is too big	Excessive steering angle sensor output offset	<Ref. to VDC(diag)-77, DTC C0071 STEERING ANGLE SENSOR OFFSET IS TOO BIG, Diagnostic Procedure with Diagnostic Trouble Code (DTC).>
	2134H	Change range of steering angle sensor is too big	Excessive variation amount of steering angle sensor output	<Ref. to VDC(diag)-79, DTC C0071 CHANGE RANGE OF STEERING ANGLE SENSOR IS TOO BIG, Diagnostic Procedure with Diagnostic Trouble Code (DTC).>
	212EH 2132H 2136H 2138H 213CH 2150H 2151H 2152H 2153H 2154H 2155H 2156H 2157H 2158H 2159H 215AH	Steering angle sensor malfunction	Steering angle sensor output	<Ref. to VDC(diag)-81, DTC C0071 STEERING ANGLE SENSOR MALFUNCTION, Diagnostic Procedure with Diagnostic Trouble Code (DTC).>
	2104H	Steering angle sensor power supply malfunction	Steering angle sensor power supply malfunction	<Ref. to VDC(diag)-83, DTC C0071 STEERING ANGLE SENSOR MALFUNCTION, Diagnostic Procedure with Diagnostic Trouble Code (DTC).>

List of Diagnostic Trouble Code (DTC)

VEHICLE DYNAMICS CONTROL (VDC) (DIAGNOSTICS)

Brought to you by Eris Studios
NOT FOR RESALE

DTC	Detailed code	Display	Content of diagnosis	Reference target
C0072	1E1AH 1E1EH 1E22H 1E26H 1E28H 1E2CH 1E34H 1E38H 1E3AH 1E3FH	Abnormal yaw rate sensor output	Yaw rate sensor output	<Ref. to VDC(diag)-85, DTC C0072 ABNORMAL YAW RATE SENSOR OUTPUT, Diagnostic Procedure with Diagnostic Trouble Code (DTC).>
	1EB6H	Voltage inputted to Yaw Rate Sensor exceeds specification	Yaw rate sensor power supply/output	<Ref. to VDC(diag)-87, DTC C0072 VOLTAGE INPUTTED TO YAW RATE SENSOR EXCEEDS SPECIFICATION, Diagnostic Procedure with Diagnostic Trouble Code (DTC).>
	1E30H	Change range of yaw rate sensor signal is too big	Excessive variation amount of yaw rate sensor output	<Ref. to VDC(diag)-89, DTC C0072 CHANGE RANGE OF YAW RATE SENSOR SIGNAL IS TOO BIG, Diagnostic Procedure with Diagnostic Trouble Code (DTC).>
	1EB7H 1EBFH 1EB5H 1EBCH 1EBDH 1EBEH 1EC0H 1EC2H 1EC3H 1EC4H 1EC6H 1ECEH 1ECFH 1ED0H 1ED3H 1ED4H 1ED5H	Yaw rate sensor communication	Yaw rate sensor communication	<Ref. to VDC(diag)-91, DTC C0072 YAW RATE SENSOR COMMUNICATION, Diagnostic Procedure with Diagnostic Trouble Code (DTC).>
	1EB9H 1ED6H	Sensor type abnormal	Different yaw rate sensor specification	<Ref. to VDC(diag)-93, DTC C0072 SENSOR TYPE ABNORMAL, Diagnostic Procedure with Diagnostic Trouble Code (DTC).>
C0073	1D46H 1D47H	Lateral G sensor offset is too big	Excessive amount of lateral G sensor output offset	<Ref. to VDC(diag)-93, DTC C0073 LATERAL G SENSOR OFFSET IS TOO BIG, Diagnostic Procedure with Diagnostic Trouble Code (DTC).>
	1D44H 1D45H	Abnormal lateral G sensor output	Lateral G sensor output	<Ref. to VDC(diag)-93, DTC C0073 ABNORMAL LATERAL G SENSOR OUTPUT, Diagnostic Procedure with Diagnostic Trouble Code (DTC).>
	1D49H	Excessive lateral G sensor signal	Excessive lateral G sensor output	<Ref. to VDC(diag)-94, DTC C0073 EXCESSIVE LATERAL G SENSOR SIGNAL, Diagnostic Procedure with Diagnostic Trouble Code (DTC).>
C0074	1F4EH 1F4FH 1FB1H 1FC0H	Pressure sensor	Pressure sensor	<Ref. to VDC(diag)-96, DTC C0074 PRESSURE SENSOR, Diagnostic Procedure with Diagnostic Trouble Code (DTC).>
C0075	2510H 2520H	Reverse signal	Abnormal reverse signal	<Ref. to VDC(diag)-97, DTC C0075 REVERSE SIGNAL, Diagnostic Procedure with Diagnostic Trouble Code (DTC).>
C0076	2610H 2620H	Clutch signal	Abnormal clutch signal	<Ref. to VDC(diag)-99, DTC C0076 CLUTCH SIGNAL, Diagnostic Procedure with Diagnostic Trouble Code (DTC).>

List of Diagnostic Trouble Code (DTC)

VEHICLE DYNAMICS CONTROL (VDC) (DIAGNOSTICS)

Brought to you by Eris Studios
NOT FOR RESALE

DTC	Detailed code	Display	Content of diagnosis	Reference target
C0081	2201H 2202H	System malfunction	System malfunction	<Ref. to VDC(diag)-100, DTC C0081 SYSTEM FAILURE, Diagnostic Procedure with Diagnostic Trouble Code (DTC).>

Diagnostic Procedure with Diagnostic Trouble Code (DTC)

VEHICLE DYNAMICS CONTROL (VDC) (DIAGNOSTICS)

Brought to you by Eris Studios
NOT FOR RESALE

12. Diagnostic Procedure with Diagnostic Trouble Code (DTC)

A: DTC C0021 FRONT RIGHT ABS SENSOR CIRCUIT OPEN OR SHORT

NOTE:

For the diagnostic procedure, refer to DTC C0027 “RL WHEEL SPEED SENSOR CIRCUIT OPEN/HIGH INPUT”. <Ref. to VDC(diag)-39, DTC C0027 REAR LEFT ABS SENSOR CIRCUIT OPEN OR SHORT, Diagnostic Procedure with Diagnostic Trouble Code (DTC).>

B: DTC C0023 FRONT LEFT ABS SENSOR CIRCUIT OPEN OR SHORT

NOTE:

For the diagnostic procedure, refer to DTC C0027 “RL WHEEL SPEED SENSOR CIRCUIT OPEN/HIGH INPUT”. <Ref. to VDC(diag)-39, DTC C0027 REAR LEFT ABS SENSOR CIRCUIT OPEN OR SHORT, Diagnostic Procedure with Diagnostic Trouble Code (DTC).>

C: DTC C0025 REAR RIGHT ABS SENSOR CIRCUIT OPEN OR SHORT

NOTE:

For the diagnostic procedure, refer to DTC C0027 “RL WHEEL SPEED SENSOR CIRCUIT OPEN/HIGH INPUT”. <Ref. to VDC(diag)-39, DTC C0027 REAR LEFT ABS SENSOR CIRCUIT OPEN OR SHORT, Diagnostic Procedure with Diagnostic Trouble Code (DTC).>

Diagnostic Procedure with Diagnostic Trouble Code (DTC)

VEHICLE DYNAMICS CONTROL (VDC) (DIAGNOSTICS)

Brought to you by Eris Studios
NOT FOR SALE

D: DTC C0027 REAR LEFT ABS SENSOR CIRCUIT OPEN OR SHORT

DTC DETECTING CONDITION:

- Defective ABS wheel speed sensor (broken wire, input voltage too high)
- Defective harness connector

TROUBLE SYMPTOM:

- ABS does not operate.
- VDC does not operate.

WIRING DIAGRAM:

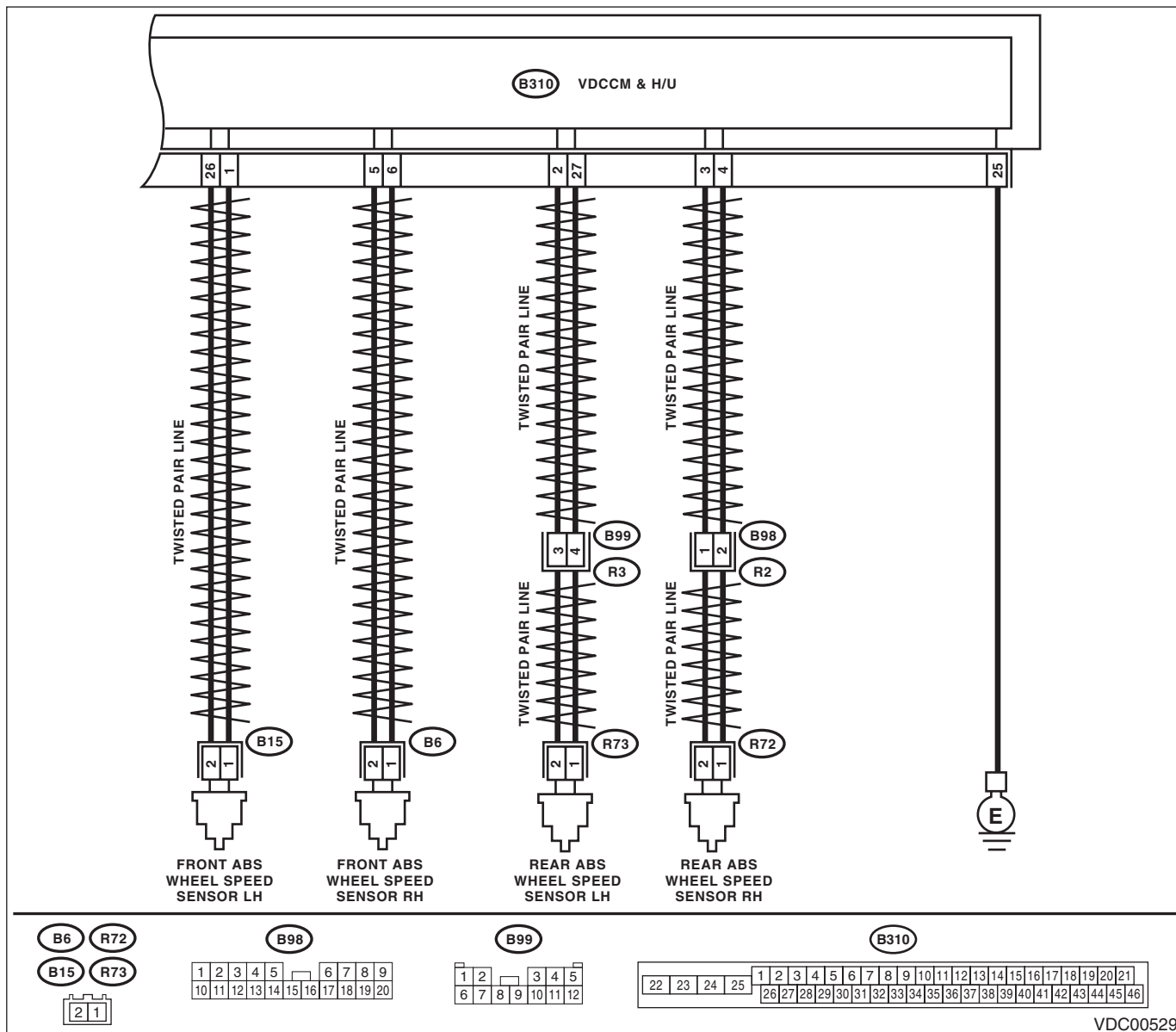

Diagnostic Procedure with Diagnostic Trouble Code (DTC)

VEHICLE DYNAMICS CONTROL (VDC) (DIAGNOSTICS)

Brought to you by Eris Studios
NOT FOR RESALE

	Step	Check	Yes	No
1	CHECK POOR CONTACT IN CONNECTOR. Check if there is poor contact between VDCCM&H/U and ABS wheel speed sensor.	Is there poor contact?	Repair the connector.	Go to step 2.
2	CHECK HARNESS CONNECTOR BETWEEN VDCCM&H/U AND ABS WHEEL SPEED SENSOR. 1) Disconnect the connector (B310) from the VDCCM&H/U. 2) Disconnect the connector from the ABS wheel speed sensor. 3) Measure the resistance between VDCCM&H/U connector and ABS wheel speed sensor connector. Connector & terminal DTC C0021 <i>(B310) No. 6 — (B6) No. 1:</i> <i>(B310) No. 5 — (B6) No. 2:</i> DTC C0023 <i>(B310) No. 1 — (B15) No. 1:</i> <i>(B310) No. 26 — (B15) No. 2:</i> DTC C0025 <i>(B310) No. 4 — (R72) No. 1:</i> <i>(B310) No. 3 — (R72) No. 2:</i> DTC C0027 <i>(B310) No. 27 — (R73) No. 1:</i> <i>(B310) No. 2 — (R73) No. 2:</i>	Is the resistance less than 0.5 Ω?	Go to step 3.	Repair the harness connector between VDCCM&H/U and ABS wheel speed sensor.
3	CHECK GROUND SHORT OF HARNESS. Measure the resistance between VDCCM&H/U connector and chassis ground. Connector & terminal DTC C0021 <i>(B310) No. 6 — Chassis ground:</i> DTC C0023 <i>(B310) No. 1 — Chassis ground:</i> DTC C0025 <i>(B310) No. 4 — Chassis ground:</i> DTC C0027 <i>(B310) No. 27 — Chassis ground:</i>	Is the resistance 1 MΩ or more?	Go to step 4.	Repair the harness connector between VDCCM&H/U and ABS wheel speed sensor.
4	CHECK ABS WHEEL SPEED SENSOR POWER SUPPLY CIRCUIT. 1) Connect the VDCCM&H/U connector. 2) Turn the ignition switch to ON. 3) Measure the voltage between ABS wheel speed sensor connector and chassis ground. Connector & terminal DTC C0021 <i>(B6) No. 2 (+) — Chassis ground (-):</i> DTC C0023 <i>(B15) No. 2 (+) — Chassis ground (-):</i> DTC C0025 <i>(R72) No. 2 (+) — Chassis ground (-):</i> DTC C0027 <i>(R73) No. 2 (+) — Chassis ground (-):</i>	Is the voltage 5 — 16 V?	Go to step 6.	Go to step 5.

Diagnostic Procedure with Diagnostic Trouble Code (DTC)

VEHICLE DYNAMICS CONTROL (VDC) (DIAGNOSTICS)

Brought to you by Eris Studios
NOT FOR SALE

Step	Check	Yes	No
5 CHECK THE VDCCM&H/U POWER SUPPLY CIRCUIT. 1) Turn the ignition switch to OFF. 2) Disconnect the VDCCM&H/U connector. 3) Turn the ignition switch to ON. 4) Measure the voltage between VDCCM&H/U connector terminals. Connector & terminal (B310) No. 28 (+) — (B310) No. 25 (-):	Is the voltage 10 — 15 V?	Go to step 6.	Check the generator, battery and VDCCM&H/U power supply circuit.
6 CHECK ABS WHEEL SPEED SENSOR SIGNAL. 1) Install the ABS wheel speed sensor. 2) Prepare an oscilloscope. 3) Check the ABS wheel speed sensor. <Ref. to ABS-15, ABS WHEEL SPEED SENSOR, INSPECTION, Rear ABS Wheel Speed Sensor.>	Is the pattern the same waveform as shown in the figure?	Go to step 7.	Replace the ABS wheel speed sensor.
7 CHECK THE VDCCM&H/U. 1) Connect all connectors. 2) Erase the memory. 3) Perform the Inspection Mode. <Ref. to VDC(diag)-23, PROCEDURE, Inspection Mode.> 4) Read the DTC.	Is the same DTC displayed?	Replace the VDCCM only. <Ref. to VDC-10, REPLACEMENT, VDC Control Module and Hydraulic Control Unit (VDCCM&H/U).>	Go to step 8.
8 CHECK OTHER DTC DETECTION.	Is any other DTC displayed?	Perform the diagnosis according to DTC.	It results from a temporary noise interference.

E: DTC C0022 FRONT RIGHT ABS SENSOR SIGNAL

NOTE:

For the diagnostic procedure, refer to DTC C0028 “RL WHEEL SPEED SENSOR SIGNAL”. <Ref. to VDC(diag)-42, DTC C0028 REAR LEFT ABS SENSOR SIGNAL, Diagnostic Procedure with Diagnostic Trouble Code (DTC).>

F: DTC C0024 FRONT LEFT ABS SENSOR SIGNAL

NOTE:

For the diagnostic procedure, refer to DTC C0028 “RL WHEEL SPEED SENSOR SIGNAL”. <Ref. to VDC(diag)-42, DTC C0028 REAR LEFT ABS SENSOR SIGNAL, Diagnostic Procedure with Diagnostic Trouble Code (DTC).>

G: DTC C0026 REAR RIGHT ABS SENSOR SIGNAL

NOTE:

For the diagnostic procedure, refer to DTC C0028 “RL WHEEL SPEED SENSOR SIGNAL”. <Ref. to VDC(diag)-42, DTC C0028 REAR LEFT ABS SENSOR SIGNAL, Diagnostic Procedure with Diagnostic Trouble Code (DTC).>

Diagnostic Procedure with Diagnostic Trouble Code (DTC)

VEHICLE DYNAMICS CONTROL (VDC) (DIAGNOSTICS)

Brought to you by Eris Studios
NOT FOR RESALE

H: DTC C0028 REAR LEFT ABS SENSOR SIGNAL

DTC DETECTING CONDITION:

- Defective ABS wheel speed sensor signal (noise, irregular signal, etc.)
- Defective harness connector

TROUBLE SYMPTOM:

- ABS does not operate.
- VDC does not operate.

WIRING DIAGRAM:

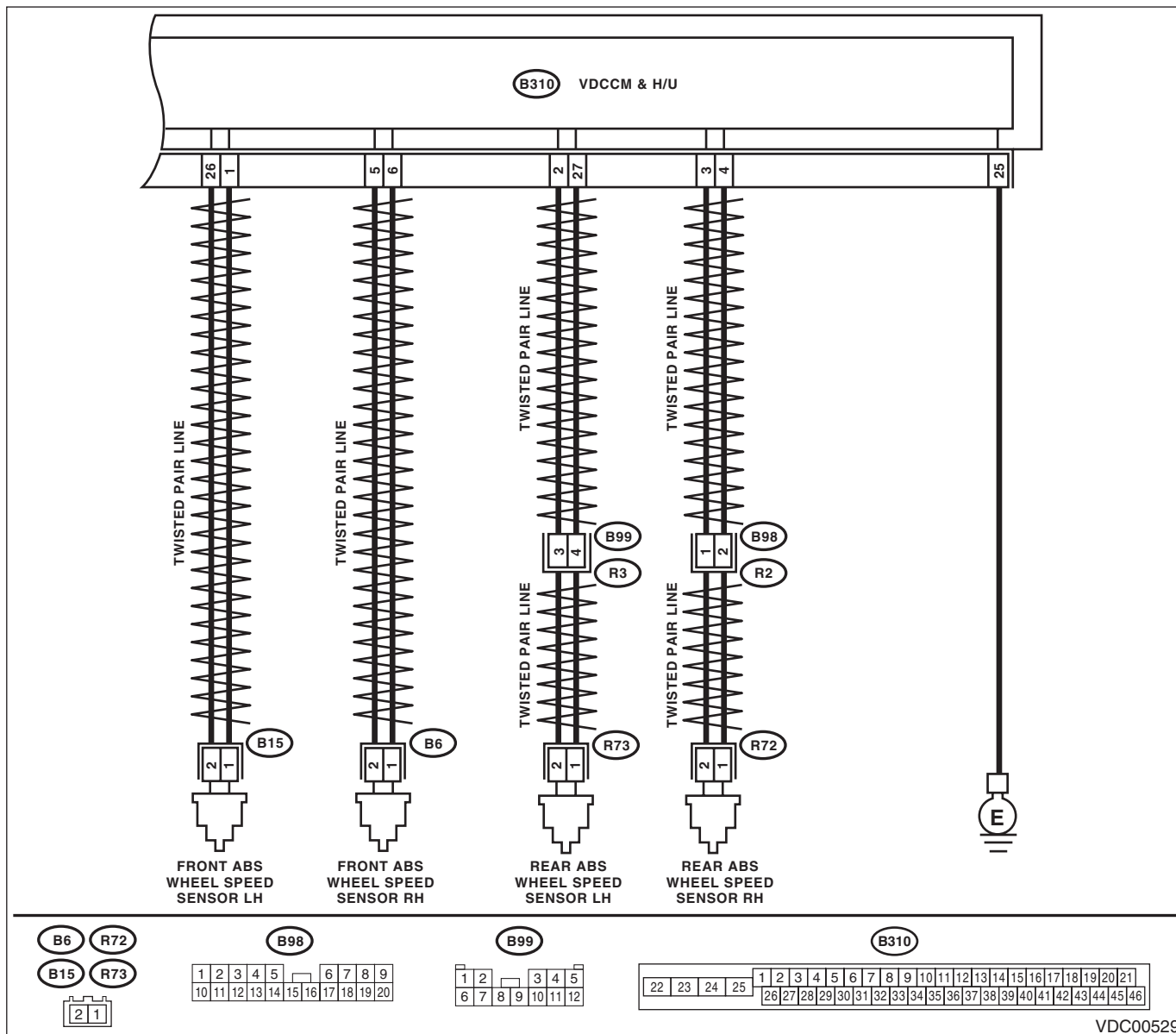

VDC00529

Diagnostic Procedure with Diagnostic Trouble Code (DTC)

VEHICLE DYNAMICS CONTROL (VDC) (DIAGNOSTICS)

Brought to you by Eriss Studios
NOT FOR RESALE

Step	Check	Yes	No
1	CHECK OUTPUT OF ABS WHEEL SPEED SENSOR USING SUBARU SELECT MONITOR. 1) Select {Current Data Display & Save} in Subaru Select Monitor. 2) Read the defective ABS wheel speed sensor output.	Does the speed indicated on the display change in response to the speedometer reading during acceleration/deceleration when the steering wheel is in the straight-ahead position?	Go to step 2. Go to step 7.
2	CHECK POOR CONTACT IN CONNECTOR. Turn the ignition switch to OFF.	Is there poor contact in connectors between VDCCM&H/U and ABS wheel speed sensor?	Repair the connector. Go to step 3.
3	CHECK CAUSE OF SIGNAL NOISE. Make sure the radio wave devices and electronic components are installed correctly.	Are the radio wave devices and electronic components installed correctly?	Go to step 4. Install the radio wave devices and electronic components properly.
4	CHECK CAUSE OF SIGNAL NOISE. Check if the noise sources (such as an antenna) are installed near the sensor harness.	Are noise sources installed?	Install the noise sources apart from sensor harness. Go to step 5.
5	CHECK THE VDCCM&H/U. 1) Connect all connectors. 2) Erase the memory. 3) Perform the Inspection Mode. <Ref. to VDC(diag)-23, PROCEDURE, Inspection Mode.> 4) Read the DTC.	Is the same DTC displayed?	Replace the VDCCM only. <Ref. to VDC-10, REPLACEMENT, VDC Control Module and Hydraulic Control Unit (VDCCM&H/U).> Go to step 6.
6	CHECK OTHER DTC DETECTION.	Is any other DTC displayed?	Perform the diagnosis according to DTC. It results from a temporary noise interference.
7	CHECK INSTALLATION OF ABS WHEEL SPEED SENSOR.	Is the ABS wheel speed sensor installation bolt tightened 7.5 N·m (0.76 kgf·m, 5.5 ft·lb)?	Go to step 8. Tighten the ABS wheel speed sensor installation bolts.
8	CHECK ABS WHEEL SPEED SENSOR SIGNAL. 1) Install the ABS wheel speed sensor. 2) Prepare an oscilloscope. 3) Check the ABS wheel speed sensor. <Ref. to ABS-14, ABS WHEEL SPEED SENSOR, INSPECTION, Front ABS Wheel Speed Sensor.>	Does the oscilloscope indicate the waveform pattern like shown in the figure when the tire is slowly turned? Does the oscilloscope indication repeat the waveform pattern like shown in the figure when the tire is slowly turned in equal speed for one rotation or more?	Go to step 10. Go to step 9.
9	CHECK ABS WHEEL SPEED SENSOR OR MAGNETIC ENCODER.	Are there foreign matter, breakage or damage at the tip of ABS wheel speed sensor or magnetic encoder?	Remove dirt thoroughly. Also replace the ABS wheel speed sensor or magnetic encoder as a unit with hub unit bearing if it is broken or damaged. Go to step 10.
10	CHECK CAUSE OF SIGNAL NOISE. Make sure the radio wave devices and electronic components are installed correctly.	Are the radio wave devices and electronic components installed correctly?	Go to step 11. Install the radio wave devices and electronic components properly.
11	CHECK CAUSE OF SIGNAL NOISE. Check if the noise sources (such as an antenna) are installed near the sensor harness.	Is the noise sources installed?	Go to step 12. Install the noise sources apart from sensor harness.

Diagnostic Procedure with Diagnostic Trouble Code (DTC)

VEHICLE DYNAMICS CONTROL (VDC) (DIAGNOSTICS)

Brought to you by Eris Studios
NOT FOR RESALE

Step	Check	Yes	No
12 CHECK THE VDCCM&H/U. 1) Connect all connectors. 2) Erase the memory. 3) Perform the Inspection Mode. <Ref. to VDC(diag)-23, PROCEDURE, Inspection Mode.> 4) Read the DTC.	Is the same DTC displayed?	Replace the VDCCM only. <Ref. to VDC-10, REPLACEMENT, VDC Control Module and Hydraulic Control Unit (VDCCM&H/U).>	Go to step 13.
13 CHECK OTHER DTC DETECTION.	Is any other DTC displayed?	Perform the diagnosis according to DTC.	It results from a temporary noise interference. NOTE: Though the ABS warning light remains on at this time, this is normal. Drive the vehicle at 12 km/h (7 MPH) or more in order to turn ABS warning light off. Be sure to drive the vehicle and check that the warning light goes off.

Diagnostic Procedure with Diagnostic Trouble Code (DTC)

VEHICLE DYNAMICS CONTROL (VDC) (DIAGNOSTICS)

Brought to you by Eris Studios
NOT FOR SALE

I: DTC C0029 ANY OF WHEEL SENSORS SIGNAL

DTC DETECTING CONDITION:

- Defective ABS wheel speed sensor signal (noise, irregular signal, etc.)
- Defective magnetic encoder
- When a wheel is turned freely for a long time

TROUBLE SYMPTOM:

- ABS does not operate.
- VDC does not operate.
- EBD may not operate.

NOTE:

Brake warning light illuminates as well as ABS warning light when EBD does not operate.

WIRING DIAGRAM:

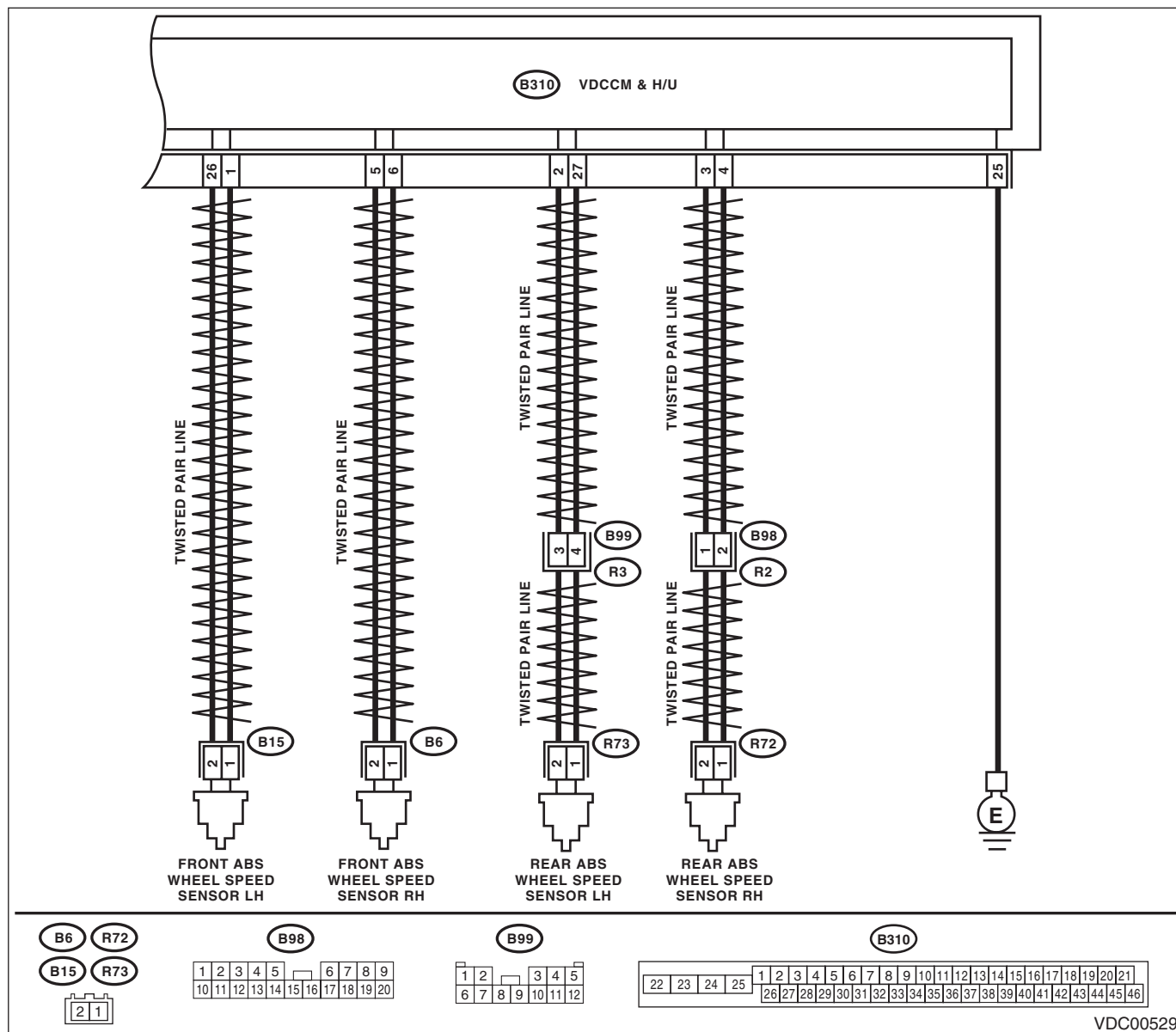

Diagnostic Procedure with Diagnostic Trouble Code (DTC)

VEHICLE DYNAMICS CONTROL (VDC) (DIAGNOSTICS)

Brought to you by Eris Studios
NOT FOR RESALE

	Step	Check	Yes	No
1	<p>WHETHER A WHEEL TURNED FREELY OR NOT. Check if the wheels have been turned freely for one minute or more, such as when the vehicle is jacked-up, under full-lock cornering or when the wheels are not in contact with road surface.</p>	Did the wheels turn freely?	VDC is normal. Erase the memory. NOTE: This diagnostic trouble code may sometimes occur if the wheels turn freely for a long time, for example when the vehicle is towed or jacked-up, or when steering wheel is continuously turned all the way.	Go to step 2.
2	<p>CHECK TIRE SPECIFICATIONS. Turn the ignition switch to OFF.</p>	Are the tire specifications correct?	Go to step 3.	Replace the tire.
3	<p>CHECK WEAR OF TIRE.</p>	Is the tire worn excessively?	Replace the tire.	Go to step 4.
4	<p>CHECK TIRE INFLATION PRESSURE.</p>	Is the tire pressure correct?	Go to step 5.	Adjust the tire pressure.
5	<p>CHECK INSTALLATION OF ABS WHEEL SPEED SENSOR.</p>	Are the ABS wheel speed sensor installation bolts tightened 7.5 N·m (0.76 kgf-m, 5.5 ft-lb)? (For four wheels)	Go to step 6.	Tighten the ABS wheel speed sensor installation bolts.
6	<p>CHECK ABS WHEEL SPEED SENSOR SIGNAL. 1) Install the ABS wheel speed sensor. 2) Prepare an oscilloscope. 3) Check the ABS wheel speed sensor. <Ref. to ABS-14, ABS WHEEL SPEED SENSOR, INSPECTION, Front ABS Wheel Speed Sensor.></p>	Does the oscilloscope indicate the waveform pattern like shown in the figure when the tire is slowly turned? Does the oscilloscope indication repeat the waveform pattern like shown in the figure when the tire is slowly turned in equal speed for one rotation or more?	Go to step 8.	Go to step 7.
7	<p>CHECK ABS WHEEL SPEED SENSOR OR MAGNETIC ENCODER.</p>	Are there foreign matter, breakage or damage at the tip of ABS wheel speed sensor or magnetic encoder?	Remove dirt thoroughly. Also replace the ABS wheel speed sensor or magnetic encoder as a unit with hub unit bearing if it is broken or damaged.	Go to step 8.
8	<p>CHECK THE VDCCM&H/U. 1) Connect all connectors. 2) Erase the memory. 3) Perform the Inspection Mode. <Ref. to VDC(diag)-23, PROCEDURE, Inspection Mode.> 4) Read the DTC.</p>	Is the same DTC displayed?	Replace the VDCCM only. <Ref. to VDC-10, REPLACEMENT, VDC Control Module and Hydraulic Control Unit (VDCCM&H/U).>	Go to step 9.

Diagnostic Procedure with Diagnostic Trouble Code (DTC)

VEHICLE DYNAMICS CONTROL (VDC) (DIAGNOSTICS)

Step	Check	Yes	No	
9	CHECK OTHER DTC DETECTION.	Is any other DTC displayed?	Perform the diagnosis according to DTC.	It results from a temporary noise interference. NOTE: Though the ABS warning light remains on at this time, this is normal. Drive the vehicle at 12 km/h (7 MPH) or more in order to turn ABS warning light off. Be sure to drive the vehicle and check that the warning light goes off.

J: DTC C0031 FR HOLD VALVE MALFUNCTION

NOTE:

For the diagnostic procedure, refer to DTC C0064 "VDC SWITCHING VALVE 2 (P)". <Ref. to VDC(diag)-49, DTC C0064 NORMAL CLOSING VALVE 2 MALFUNCTION, Diagnostic Procedure with Diagnostic Trouble Code (DTC).>

K: DTC C0032 FR PRESSURE REDUCING VALVE MALFUNCTION

NOTE:

For the diagnostic procedure, refer to DTC C0064 "VDC SWITCHING VALVE 2 (P)". <Ref. to VDC(diag)-49, DTC C0064 NORMAL CLOSING VALVE 2 MALFUNCTION, Diagnostic Procedure with Diagnostic Trouble Code (DTC).>

L: DTC C0033 FL HOLD VALVE MALFUNCTION

NOTE:

For the diagnostic procedure, refer to C0064 "VDC SWITCHING VALVE 2 (P)". <Ref. to VDC(diag)-49, DTC C0064 NORMAL CLOSING VALVE 2 MALFUNCTION, Diagnostic Procedure with Diagnostic Trouble Code (DTC).>

M: DTC C0034 FL PRESSURE REDUCING VALVE MALFUNCTION

NOTE:

For the diagnostic procedure, refer to C0064 "VDC SWITCHING VALVE 2 (P)". <Ref. to VDC(diag)-49, DTC C0064 NORMAL CLOSING VALVE 2 MALFUNCTION, Diagnostic Procedure with Diagnostic Trouble Code (DTC).>

N: DTC C0035 RR HOLD VALVE MALFUNCTION

NOTE:

For the diagnostic procedure, refer to C0064 "VDC SWITCHING VALVE 2 (P)". <Ref. to VDC(diag)-49, DTC C0064 NORMAL CLOSING VALVE 2 MALFUNCTION, Diagnostic Procedure with Diagnostic Trouble Code (DTC).>

O: DTC C0036 RR PRESSURE REDUCING VALVE MALFUNCTION

NOTE:

For the diagnostic procedure, refer to C0064 "VDC SWITCHING VALVE 2 (P)". <Ref. to VDC(diag)-49, DTC C0064 NORMAL CLOSING VALVE 2 MALFUNCTION, Diagnostic Procedure with Diagnostic Trouble Code (DTC).>

Diagnostic Procedure with Diagnostic Trouble Code (DTC)

VEHICLE DYNAMICS CONTROL (VDC) (DIAGNOSTICS)

Brought to you by Eris Studios
NOT FOR RESALE

P: DTC C0037 RL HOLD VALVE MALFUNCTION

NOTE:

For the diagnostic procedure, refer to C0064 "VDC SWITCHING VALVE 2 (P)". <Ref. to VDC(diag)-49, DTC C0064 NORMAL CLOSING VALVE 2 MALFUNCTION, Diagnostic Procedure with Diagnostic Trouble Code (DTC).>

Q: DTC C0038 RL PRESSURE REDUCING VALVE MALFUNCTION

NOTE:

For the diagnostic procedure, refer to C0064 "VDC SWITCHING VALVE 2 (P)". <Ref. to VDC(diag)-49, DTC C0064 NORMAL CLOSING VALVE 2 MALFUNCTION, Diagnostic Procedure with Diagnostic Trouble Code (DTC).>

R: DTC C0039 ANY ONE OF FOUR SOLENOID VALVES

NOTE:

For the diagnostic procedure, refer to C0064 "VDC SWITCHING VALVE 2 (P)". <Ref. to VDC(diag)-49, DTC C0064 NORMAL CLOSING VALVE 2 MALFUNCTION, Diagnostic Procedure with Diagnostic Trouble Code (DTC).>

S: DTC C0061 NORMAL OPENING VALVE 1 MALFUNCTION

NOTE:

For the diagnostic procedure, refer to C0064 "VDC SWITCHING VALVE 2 (P)". <Ref. to VDC(diag)-49, DTC C0064 NORMAL CLOSING VALVE 2 MALFUNCTION, Diagnostic Procedure with Diagnostic Trouble Code (DTC).>

T: DTC C0062 NORMAL OPENING VALVE 2 MALFUNCTION

NOTE:

For the diagnostic procedure, refer to C0064 "VDC SWITCHING VALVE 2 (P)". <Ref. to VDC(diag)-49, DTC C0064 NORMAL CLOSING VALVE 2 MALFUNCTION, Diagnostic Procedure with Diagnostic Trouble Code (DTC).>

U: DTC C0063 NORMAL CLOSING VALVE 1 MALFUNCTION

NOTE:

For the diagnostic procedure, refer to C0064 "VDC SWITCHING VALVE 2 (P)". <Ref. to VDC(diag)-49, DTC C0064 NORMAL CLOSING VALVE 2 MALFUNCTION, Diagnostic Procedure with Diagnostic Trouble Code (DTC).>

Diagnostic Procedure with Diagnostic Trouble Code (DTC)

VEHICLE DYNAMICS CONTROL (VDC) (DIAGNOSTICS)

Brought to you by Eris Studios
NOT FOR SALE

V: DTC C0064 NORMAL CLOSING VALVE 2 MALFUNCTION

DTC DETECTING CONDITION:

- Defective harness connector
- Defective VDCH/U solenoid valve

TROUBLE SYMPTOM:

- ABS does not operate.
- EBD does not operate.
- VDC does not operate.

WIRING DIAGRAM:

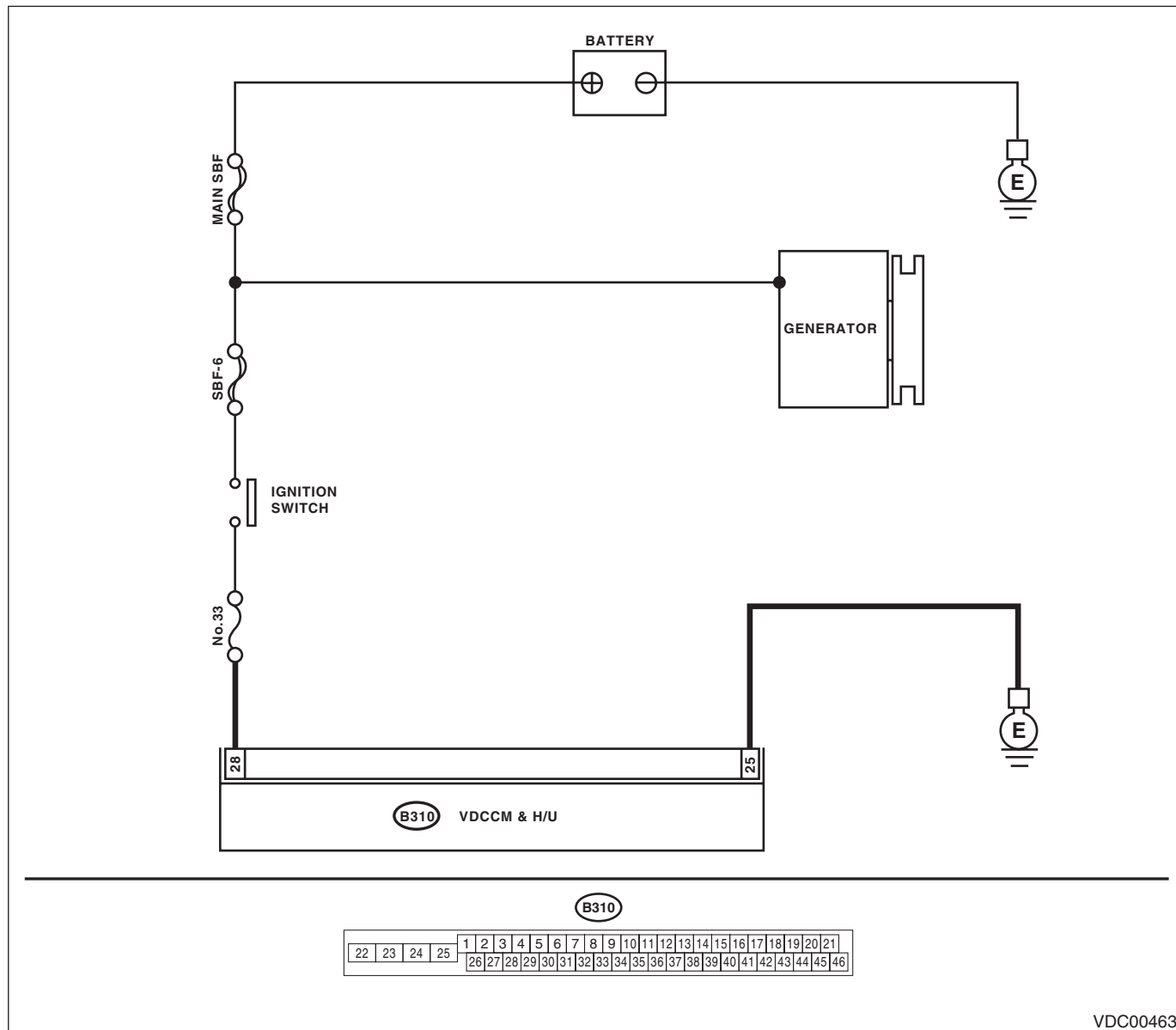

VDC00463

Diagnostic Procedure with Diagnostic Trouble Code (DTC)

VEHICLE DYNAMICS CONTROL (VDC) (DIAGNOSTICS)

Brought to you by Eris Studios
NOT FOR RESALE

Step	Check	Yes	No
1 CHECK THE VDCCM&H/U INPUT VOLTAGE. 1) Turn the ignition switch to OFF. 2) Disconnect the connector from the VDCCM&H/U. 3) Run the engine at idle. 4) Measure the voltage between VDCCM&H/U connector and chassis ground. Connector & terminal (B310) No. 28 (+) — Chassis ground (-):	Is the voltage 10 — 15 V?	Go to step 2.	Repair the power supply circuit.
2 CHECK THE VDCCM&H/U GROUND CIRCUIT. 1) Turn the ignition switch to OFF. 2) Measure the resistance between VDCCM&H/U connector and chassis ground. Connector & terminal (B310) No. 25 — Chassis ground:	Is the resistance less than 0.5 Ω?	Go to step 3.	Repair the VDCCM&H/U ground harness.
3 CHECK POOR CONTACT IN CONNECTORS.	Is there poor contact in connector between generator, battery and VDCCM&H/U?	Repair the connector.	Go to step 4.
4 CHECK THE VDCCM&H/U. 1) Connect all connectors. 2) Erase the memory. 3) Perform the Inspection Mode. 4) Read the DTC.	Is the same DTC displayed?	Replace the VDCCM&H/U. <Ref. to VDC-7, VDC Control Module and Hydraulic Control Unit (VDCCM&H/U).>	Go to step 5.
5 CHECK OTHER DTC DETECTION.	Is any other DTC displayed?	Perform the diagnosis according to DTC.	Temporary poor contact occurs.

Diagnostic Procedure with Diagnostic Trouble Code (DTC)

VEHICLE DYNAMICS CONTROL (VDC) (DIAGNOSTICS)

Brought to you by Eris Studios
NOT FOR SALE

W: DTC C0041 ECM

DTC DETECTING CONDITION:

Defective VDCCM&H/U

TROUBLE SYMPTOM:

- ABS does not operate.
- EBD does not operate.
- VDC does not operate.

WIRING DIAGRAM:

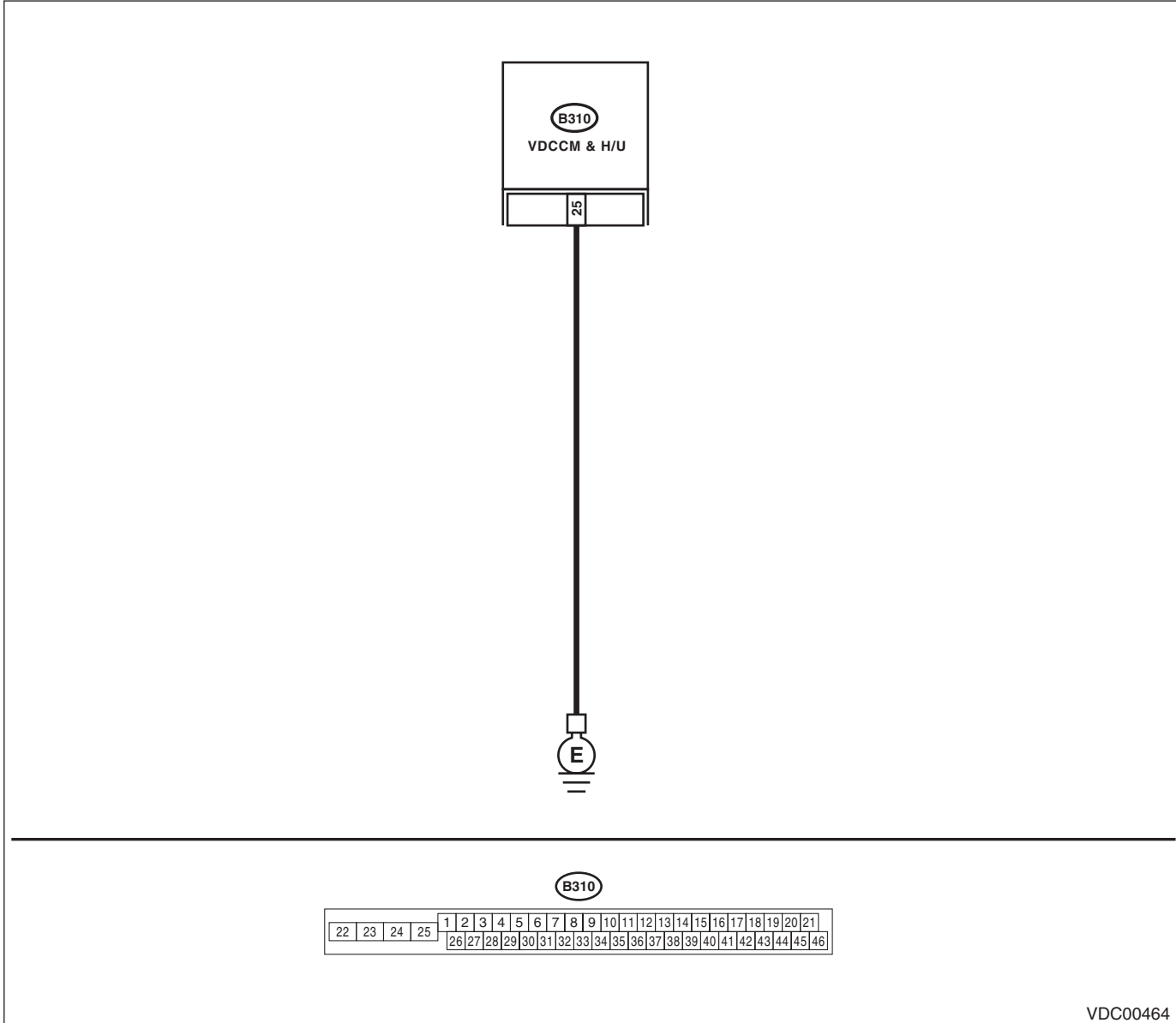

VDC00464

Diagnostic Procedure with Diagnostic Trouble Code (DTC)

VEHICLE DYNAMICS CONTROL (VDC) (DIAGNOSTICS)

Brought to you by Eris Studios
NOT FOR RESALE

Step	Check	Yes	No
1 CHECK THE VDCCM&H/U GROUND CIRCUIT. 1) Turn the ignition switch to OFF. 2) Disconnect the connector from the VDCCM&H/U. 3) Measure the resistance between VDCCM&H/U and chassis ground. Connector & terminal (B310) No. 25 — Chassis ground:	Is the resistance less than 0.5 Ω?	Go to step 2.	Repair the VDCCM&H/U ground harness.
2 CHECK POOR CONTACT IN CONNECTORS.	Is there poor contact of the connector between the battery, ignition switch and VDCCM&H/U?	Repair the connector.	Go to step 3.
3 CHECK CAUSE OF SIGNAL NOISE.	Are the radio wave devices and electronic components installed correctly?	Go to step 4.	Install the radio wave devices and electronic components properly.
4 CHECK CAUSE OF SIGNAL NOISE.	Is there a noise source (such as an antenna) installed near the sensor harness?	Install the noise sources apart from the sensor harness.	Go to step 5.
5 CHECK THE VDCCM&H/U. 1) Connect all connectors. 2) Erase the memory. 3) Perform the Inspection Mode. 4) Read the DTC.	Is the same DTC displayed?	Replace the VDCCM only. <Ref. to VDC-10, REPLACEMENT, VDC Control Module and Hydraulic Control Unit (VDCCM&H/U).>	Go to step 6.
6 CHECK OTHER DTC DETECTION.	Is any other DTC displayed?	Perform the diagnosis according to DTC. <Ref. to VDC(diag)-32, List of Diagnostic Trouble Code (DTC).>	Temporary poor contact occurs.

Diagnostic Procedure with Diagnostic Trouble Code (DTC)

VEHICLE DYNAMICS CONTROL (VDC) (DIAGNOSTICS)

Brought to you by Eris Studios
NOT FOR SALE

X: DTC C0041 PARAMETER SELECTION ERROR

DTC DETECTING CONDITION:

VDCCM parameter selection failure

TROUBLE SYMPTOM:

- ABS does not operate.
- EBD does not operate.
- VDC does not operate.

NOTE:

When the VDCCM or VDCCM&H/U is replaced, this DTC may be memorized.

	Step	Check	Yes	No
1	CHECK VDCCM&H/U REPLACEMENT HISTORY.	Is there replacement history of VDCCM alone?	Go to step 2.	Go to step 3.
2	CHECK VDCCM IDENTIFICATION NUMBER. Check the identification number on the sticker attached on the VDCCM side.	Is the identification number correct? AT:S1 MT:S2	Go to step 4.	Replace the VDCCM only.
3	CHECK VDCCM&H/U IDENTIFICATION NUMBER. Check the identification number stamped on the upper side of the H/U.	Is the identification number correct? AT:S1 MT:S2	Go to step 4.	Replace the VDCCM&H/U.
4	CHECK PARAMETER SELECTED FOR VDCCM. <Ref. to VDC(diag)-18, PARAMETER CHECK, OPERATION, Subaru Select Monitor.>	Does the parameter registered to the VDCCM match with the target vehicle?	Replace the VDCCM only.	Select and register the correct parameter. <Ref. to VDC(diag)-18, PARAMETER SELECTION, OPERATION, Subaru Select Monitor.>

Diagnostic Procedure with Diagnostic Trouble Code (DTC)

Brought to you by Eris Studios
NOT FOR RESALE

VEHICLE DYNAMICS CONTROL (VDC) (DIAGNOSTICS)

Y: DTC C0042 POWER SUPPLY VOLTAGE FAILURE

DTC DETECTING CONDITION:

CHECK THE VDCCM&H/U power supply voltage.

TROUBLE SYMPTOM:

- ABS does not operate.
- EBD may not operate.
- VDC does not operate.

NOTE:

Warning lights go off if voltage returns.

WIRING DIAGRAM:

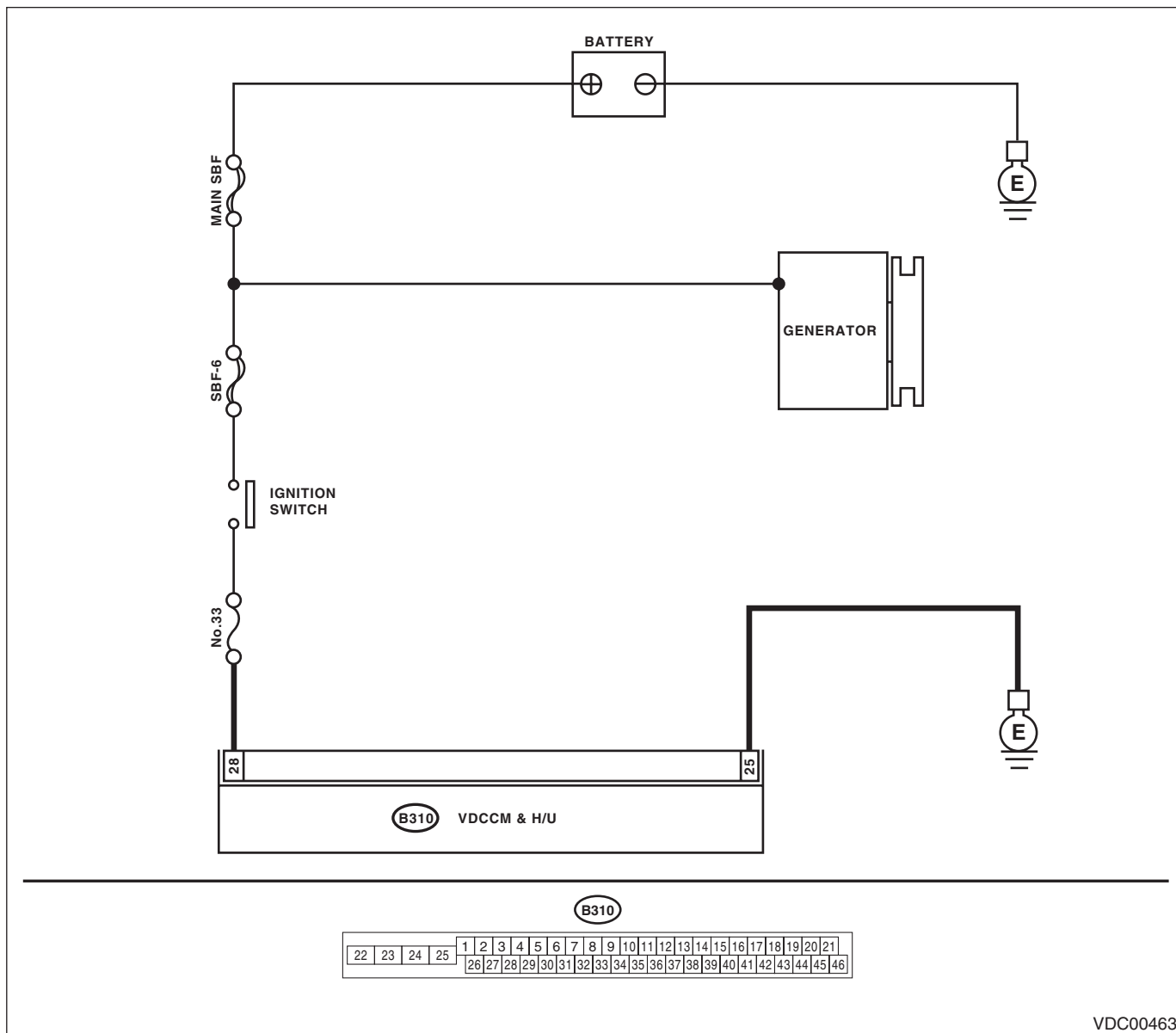

VDC00463

Diagnostic Procedure with Diagnostic Trouble Code (DTC)

VEHICLE DYNAMICS CONTROL (VDC) (DIAGNOSTICS)

Brought to you by Eris Studios
NOT FOR SALE

	Step	Check	Yes	No
1	CHECK GENERATOR. 1) Start the engine. 2) Run the engine at idle after warming up. 3) Measure the voltage between generator terminal B and chassis ground. Terminals Generator B terminal (+) — Chassis ground (-):	Is the voltage 10 — 15 V?	Go to step 2.	Repair the generator.
2	CHECK BATTERY TERMINAL. Turn the ignition switch to OFF.	Are the positive and negative battery terminals clamped tightly?	Go to step 3.	Tighten the terminal.
3	CHECK THE VDCCM&H/U INPUT VOLTAGE. 1) Disconnect the connector from the VDCCM&H/U. 2) Run the engine at idle. 3) Operate devices such as headlights, air conditioner, defogger, etc. which produce an electrical load. 4) Measure the voltage between VDCCM&H/U connector and chassis ground. Connector & terminal (B310) No. 28 (+) — Chassis ground (-):	Is the voltage 10 — 15 V?	Go to step 4.	Repair the power supply circuit.
4	CHECK THE VDCCM&H/U GROUND CIRCUIT. 1) Turn the ignition switch to OFF. 2) Measure the resistance between VDCCM&H/U connector and chassis ground. Connector & terminal (B310) No. 25 — Chassis ground:	Is the resistance less than 0.5 Ω ?	Go to step 5.	Repair the VDCCM&H/U ground harness.
5	CHECK POOR CONTACT IN CONNECTORS.	Is there poor contact in connector between generator, battery and VDCCM&H/U?	Repair the connector.	Go to step 6.
6	CHECK THE VDCCM&H/U. 1) Connect all connectors. 2) Erase the memory. 3) Perform the Inspection Mode. 4) Read the DTC.	Is the same DTC displayed?	Replace the VDCCM only. <Ref. to VDC-10, REPLACEMENT, VDC Control Module and Hydraulic Control Unit (VDCCM&H/U).>	Go to step 7.
7	CHECK OTHER DTC DETECTION.	Is any other DTC displayed?	Perform the diagnosis according to DTC. <Ref. to VDC(diag)-32, List of Diagnostic Trouble Code (DTC).>	Temporary poor contact occurs.

Diagnostic Procedure with Diagnostic Trouble Code (DTC)

VEHICLE DYNAMICS CONTROL (VDC) (DIAGNOSTICS)

Brought to you by Eris Studios
NOT FOR RESALE

Z: DTC C0044 TCM COMMUNICATION CIRCUIT

DTC DETECTING CONDITION:

No CAN signal from TCM.

TROUBLE SYMPTOM:

- ABS does not operate.
- VDC does not operate.

	Step	Check	Yes	No
1	CHECK LAN SYSTEM. Perform the diagnosis for LAN system. <Ref. to LAN(diag)-29, OPERATION, Read Diagnostic Trouble Code (DTC).>	Is there any fault in LAN system?	Perform the diagnosis according to DTC for LAN system.	Go to step 2.
2	CHECK POOR CONTACT IN CONNECTORS.	Is there poor contact in TCM connector?	Repair the connector.	Go to step 3.
3	CHECK TCM.	Is the TCM normal?	Go to step 4.	Replace the TCM. <Ref. to 4AT-64, Transmission Control Module (TCM).>
4	CHECK THE VDCCM&H/U. 1) Connect all connectors. 2) Erase the memory. 3) Perform the Inspection Mode. 4) Read the DTC.	Is the same DTC displayed?	Replace the VDCCM only.	Go to step 5.
5	CHECK OTHER DTC DETECTION.	Is any other DTC displayed?	Perform the diagnosis according to DTC.	It results from a temporary noise interference.

Diagnostic Procedure with Diagnostic Trouble Code (DTC)

VEHICLE DYNAMICS CONTROL (VDC) (DIAGNOSTICS)

Brought to you by Eris Studios
NOT FOR SALE

AA:DTC C0045 INCORRECT VDC CONTROL MODULE SPECIFICATIONS

DTC DETECTING CONDITION:

Different control module specification

TROUBLE SYMPTOM:

- ABS does not operate.
- VDC does not operate.

NOTE:

When parameter selection for VDCCM is improper, this DTC may be memorized.

Step	Check	Yes	No
1	CHECK VDCCM REPLACEMENT HISTORY. Is there replacement history of VDCCM alone?	Go to step 2.	Go to step 3.
2	CHECK VDCCM IDENTIFICATION NUMBER. Check the identification number on the sticker attached on the VDCCM side. AT:S1 MT:S2	Go to step 4.	Replace the VDCCM only.
3	CHECK VDCCM&H/U IDENTIFICATION NUMBER. Check the identification number stamped on the upper side of the H/U. AT:S1 MT:S2	Go to step 4.	Replace the VDCCM&H/U.
4	CHECK PARAMETER SELECTED FOR VDCCM. <Ref. to VDC(diag)-18, PARAMETER CHECK, OPERATION, Subaru Select Monitor.>	Go to step 5.	Select and register the correct parameter. <Ref. to VDC(diag)-18, PARAMETER SELECTION, OPERATION, Subaru Select Monitor.>
5	CHECK TCM SPECIFICATION. Check the TCM specification.	Go to step 6.	Replace the TCM. <Ref. to 4AT-64, Transmission Control Module (TCM).>
6	CHECK AT SYSTEM. 1) Start the engine. 2) Check the DTC in AT system.	Repair the AT system.	Go to step 7.
7	CHECK ECM SPECIFICATION. Check the ECM specification.	Go to step 8.	Replace the ECM. <Ref. to FU(H4SO)-39, Engine Control Module (ECM).> <Ref. to FU(H4DOTC)-45, Engine Control Module (ECM).>
8	CHECK THE VDCCM&H/U. 1) Connect all connectors. 2) Erase the memory. 3) Perform the Inspection Mode. 4) Read the DTC.	Replace the VDCCM only.	Go to step 9.
9	CHECK OTHER DTC DETECTION. Is any other DTC displayed?	Perform the diagnosis according to DTC.	It results from a temporary noise interference.

Diagnostic Procedure with Diagnostic Trouble Code (DTC)

VEHICLE DYNAMICS CONTROL (VDC) (DIAGNOSTICS)

Brought to you by Eris Studios
NOT FOR RESALE

AB:DTC C0045 TCM MALFUNCTION

DTC DETECTING CONDITION:

Defective TCM

TROUBLE SYMPTOM:

- ABS does not operate.
- VDC does not operate.

	Step	Check	Yes	No
1	CHECK AT SYSTEM. 1) Start the engine. 2) Check the DTC in AT system.	Is DTC of AT system displayed?	Repair the AT system.	Go to step 2.
2	CHECK THE VDCCM&H/U. 1) Connect all connectors. 2) Erase the memory. 3) Perform the Inspection Mode. 4) Read the DTC.	Is the same DTC displayed?	Replace the VDCCM only.	Go to step 3.
3	CHECK OTHER DTC DETECTION.	Is any other DTC displayed?	Perform the diagnosis according to DTC.	It results from a temporary noise interference.

Diagnostic Procedure with Diagnostic Trouble Code (DTC)

VEHICLE DYNAMICS CONTROL (VDC) (DIAGNOSTICS)

Brought to you by Eris Studios
NOT FOR SALE

AC:DTC C0047 CAN COMMUNICATION

DTC DETECTING CONDITION:

CAN communication line circuit is open or shorted.

TROUBLE SYMPTOM:

- ABS does not operate.
- VDC does not operate.

WIRING DIAGRAM:

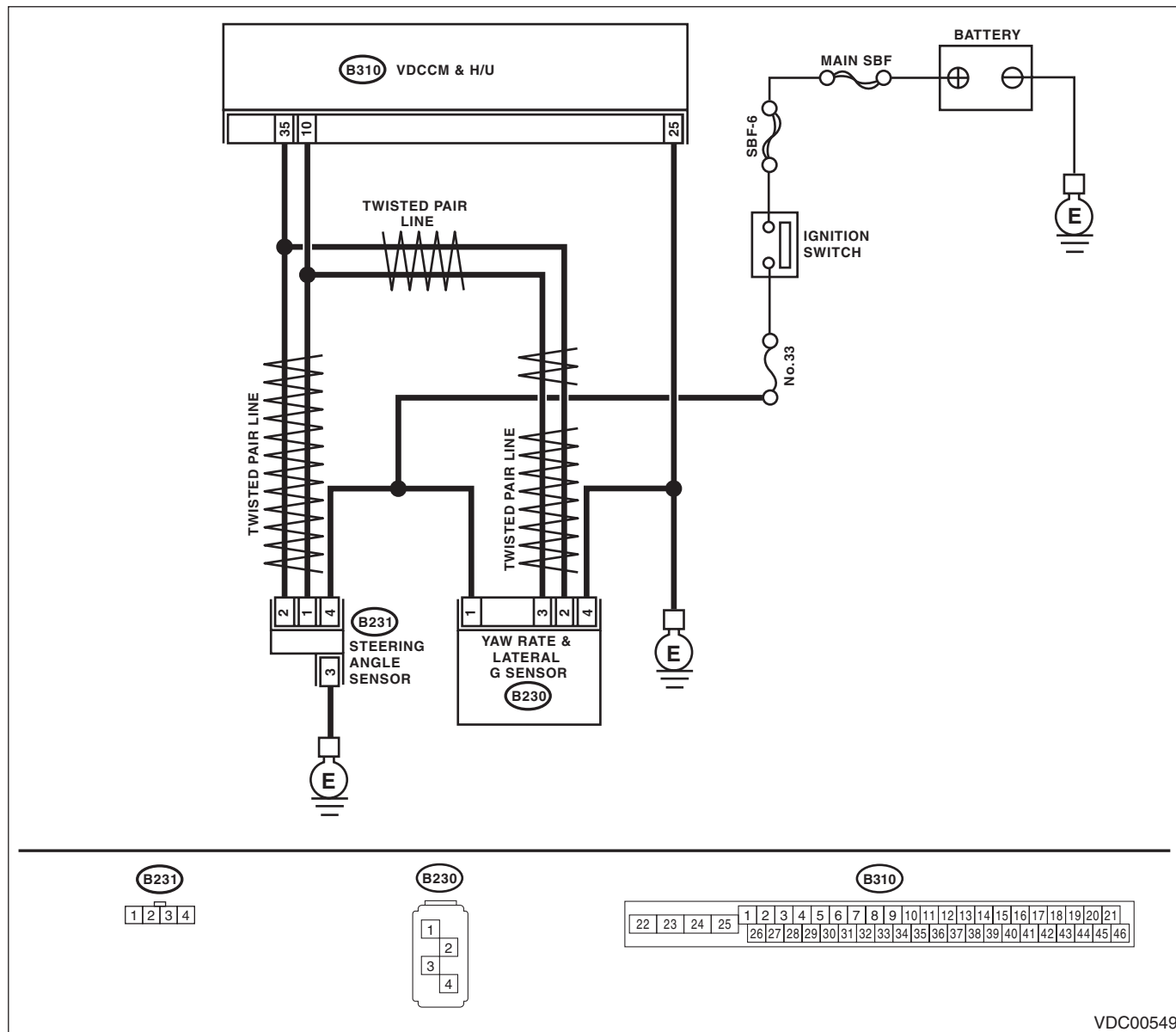

VDC00549

Diagnostic Procedure with Diagnostic Trouble Code (DTC)

VEHICLE DYNAMICS CONTROL (VDC) (DIAGNOSTICS)

Brought to you by Eris Studios
NOT FOR RESALE

Step	Check	Yes	No
1	CHECK LAN SYSTEM. Perform the diagnosis for LAN system. <Ref. to LAN(diag)-29, OPERATION, Read Diagnostic Trouble Code (DTC).>	Is there any fault in LAN system?	Perform the diagnosis according to DTC for LAN system. Go to step 2.
2	CHECK POOR CONTACT IN CONNECTORS.	Is there poor contact in VDCCM&H/U connector?	Repair the connector. Go to step 3.
3	CHECK OUTPUT OF STEERING ANGLE SENSOR. Connect the Subaru Select Monitor and check output of the steering angle sensor.	Does the output signal change?	Go to step 4. Check output of the steering angle sensor. <Ref. to VDC(diag)-81, DTC C0071 STEERING ANGLE SENSOR MALFUNCTION, Diagnostic Procedure with Diagnostic Trouble Code (DTC).>
4	CHECK OUTPUT OF YAW RATE & LATERAL G SENSOR. Connect the Subaru Select Monitor and check output of the yaw rate & lateral G sensor.	Does the output signal change?	Go to step 5. Check output of the yaw rate & lateral G sensor. <Ref. to VDC(diag)-91, DTC C0072 YAW RATE SENSOR COMMUNICATION, Diagnostic Procedure with Diagnostic Trouble Code (DTC).>
5	CHECK THE VDCCM&H/U. 1) Connect all connectors. 2) Erase the memory. 3) Perform the Inspection Mode. 4) Read the DTC.	Is the same DTC displayed?	Replace the VDCCM only. <Ref. to VDC-10, REPLACEMENT, VDC Control Module and Hydraulic Control Unit (VDCCM&H/U).> Temporary poor contact occurs.

Diagnostic Procedure with Diagnostic Trouble Code (DTC)

VEHICLE DYNAMICS CONTROL (VDC) (DIAGNOSTICS)

Brought to you by Eris Studios
 NOT FOR SALE

AD:DTC C0051 VALVE RELAY

DTC DETECTING CONDITION:

Defective valve relay

TROUBLE SYMPTOM:

- ABS does not operate.
- EBD does not operate.
- VDC does not operate.

WIRING DIAGRAM:

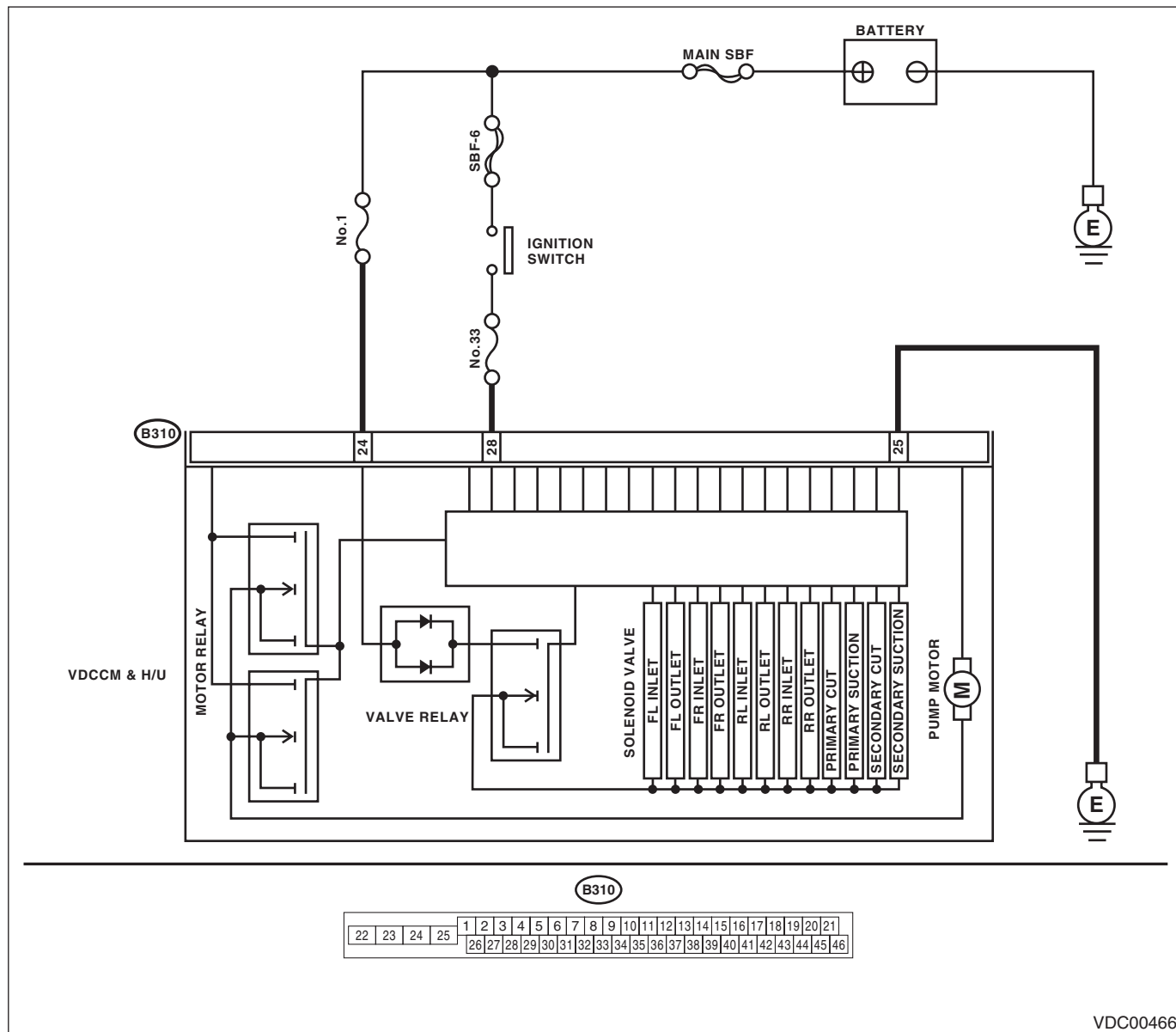

VDC00466

Diagnostic Procedure with Diagnostic Trouble Code (DTC)

VEHICLE DYNAMICS CONTROL (VDC) (DIAGNOSTICS)

Brought to you by Eris Studios
NOT FOR RESALE

Step	Check	Yes	No
1 CHECK THE VDCCM&H/U INPUT VOLTAGE. 1) Turn the ignition switch to OFF. 2) Disconnect the connector from the VDCCM&H/U. 3) Run the engine at idle. 4) Measure the voltage between VDCCM&H/U connector and chassis ground. Connector & terminal (B310) No. 28 (+) — Chassis ground (-): (B310) No. 24 (+) — Chassis ground (-):	Is the voltage 10 — 15 V?	Go to step 2.	Repair the power supply circuit.
2 CHECK THE VDCCM&H/U INPUT VOLTAGE. Calculate the voltage difference measured in step 1. A: (B310) No. 28 (+) — Chassis ground (-): B: (B310) No. 24 (+) — Chassis ground (-):	Is the voltage difference between A and B 2 V or more?	Repair the power supply circuit.	Go to step 3.
3 CHECK THE VDCCM&H/U GROUND CIRCUIT. 1) Turn the ignition switch to OFF. 2) Measure the resistance between VDCCM&H/U connector and chassis ground. Connector & terminal (B310) No. 25 — Chassis ground:	Is the resistance less than 0.5 Ω ?	Go to step 4.	Repair the VDCCM&H/U ground harness.
4 CHECK THE VDCCM&H/U VALVE RELAY. Measure the resistance between VDCCM&H/U connector terminals. Connector & terminal (B310) No. 24 — (B310) No. 25:	Is the resistance 1 M Ω or more?	Go to step 5.	Replace the VDCCM&H/U.
5 CHECK POOR CONTACT IN CONNECTORS.	Is there poor contact in connector between generator, battery and VDCCM&H/U?	Repair the connector.	Go to step 6.
6 CHECK THE VDCCM&H/U. 1) Connect all connectors. 2) Erase the memory. 3) Perform the Inspection Mode. 4) Read the DTC.	Is the same DTC displayed?	Replace the VDCCM only. <Ref. to VDC-10, REPLACEMENT, VDC Control Module and Hydraulic Control Unit (VDCCM&H/U).>	Go to step 7.
7 CHECK OTHER DTC DETECTION.	Is any other DTC displayed?	Perform the diagnosis according to DTC.	Temporary poor contact occurs.

Diagnostic Procedure with Diagnostic Trouble Code (DTC)

VEHICLE DYNAMICS CONTROL (VDC) (DIAGNOSTICS)

Brought to you by Eris Studios
 NOT FOR SALE

AE:DTC C0052 MOTOR AND MOTOR RELAY OFF FAILURE

DTC DETECTING CONDITION:

- Defective motor and motor relay
- Defective harness connector

TROUBLE SYMPTOM:

- ABS does not operate.
- VDC does not operate.
- EBD may not operate.

WIRING DIAGRAM:

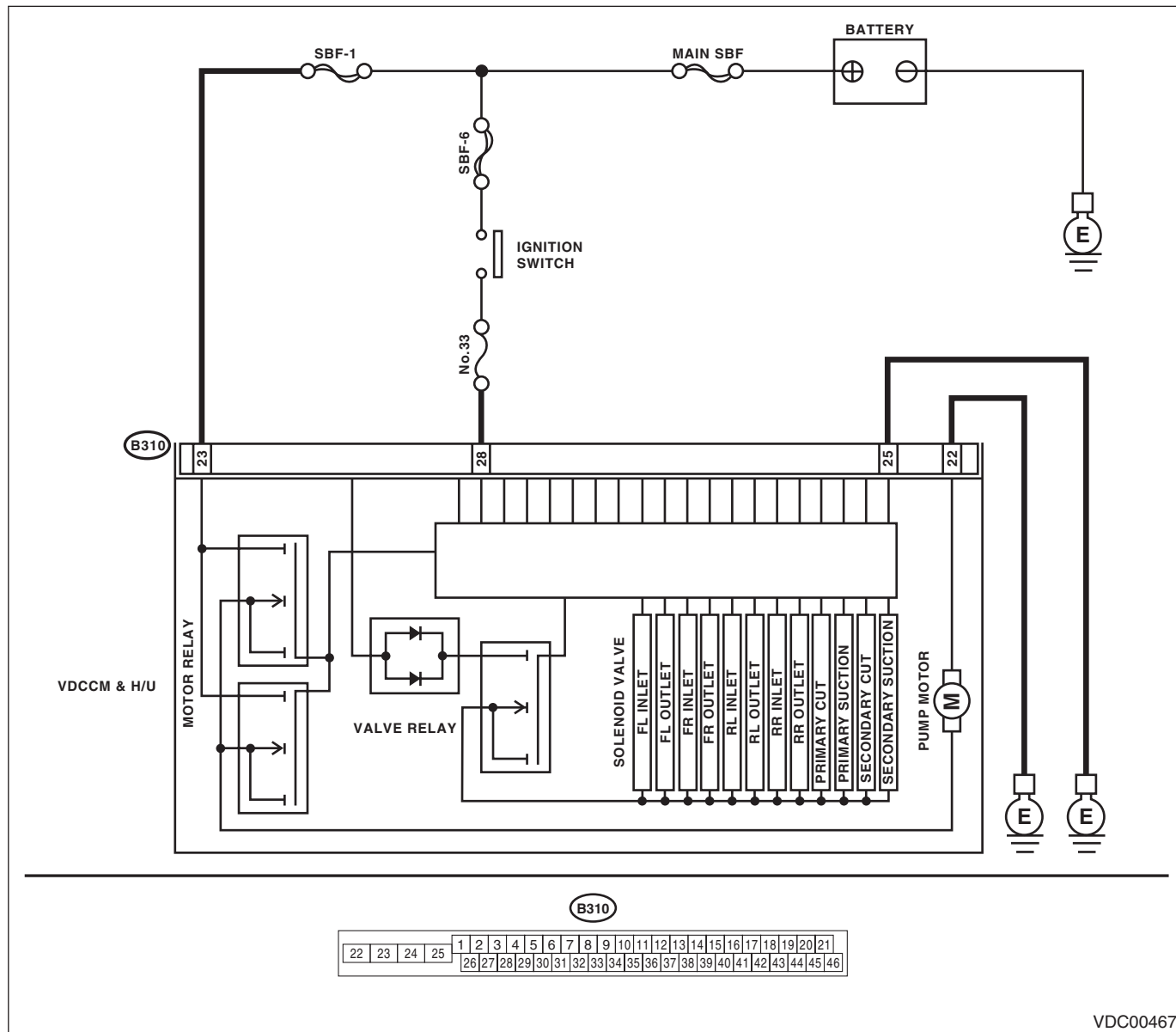

VDC00467

Diagnostic Procedure with Diagnostic Trouble Code (DTC)

VEHICLE DYNAMICS CONTROL (VDC) (DIAGNOSTICS)

Brought to you by Eris Studios
NOT FOR RESALE

Step	Check	Yes	No
1 CHECK THE VDCCM&H/U INPUT VOLTAGE. 1) Turn the ignition switch to OFF. 2) Disconnect the connector from the VDCCM&H/U. 3) Turn the ignition switch to ON. 4) Measure the voltage between VDCCM&H/U connector and chassis ground. Connector & terminal (B310) No. 23 (+) — Chassis ground (-): (B310) No. 28 (+) — Chassis ground (-):	Is the voltage 10 — 15 V?	Go to step 2.	Repair the VDCCM&H/U power supply circuit.
2 CHECK INSTALLATION OF MOTOR GROUND.	Is the motor ground terminal installation bolt tightened 33 N·m (3.4 kgf·m, 24.3 ft·lb)?	Go to step 3.	Tighten the motor ground terminal installation bolt.
3 CHECK THE VDCCM&H/U GROUND CIRCUIT. 1) Turn the ignition switch to OFF. 2) Measure the resistance between VDCCM&H/U connector and chassis ground. Connector & terminal (B310) No. 25 — Chassis ground: (B310) No. 22 — Chassis ground:	Is the resistance less than 0.5 Ω?	Go to step 4.	Repair the VDCCM&H/U ground harness.
4 CHECK VDCCM&H/U MOTOR RELAY. Measure the resistance between VDCCM&H/U connector terminals. Terminals No. 23 — No. 22:	Is the resistance 1 MΩ or more?	Go to step 5.	Replace the VDCCM&H/U.
5 CHECK POOR CONTACT IN CONNECTORS. Turn the ignition switch to OFF.	Is there poor contact in connector between generator, battery and VDCCM&H/U?	Repair the connector.	Go to step 6.
6 CHECK THE VDCCM&H/U. 1) Connect all connectors. 2) Erase the memory. 3) Perform the Inspection Mode. 4) Read the DTC.	Is the same DTC displayed?	Replace the VDCCM&H/U. <Ref. to VDC-7, VDC Control Module and Hydraulic Control Unit (VDCCM&H/U).>	Go to step 7.
7 CHECK OTHER DTC DETECTION.	Is any other DTC displayed?	Perform the diagnosis according to DTC. <Ref. to VDC(diag)-32, List of Diagnostic Trouble Code (DTC).>	Temporary poor contact occurs. NOTE: Though the ABS warning light remains on at this time, it is normal. Drive the vehicle at 12 km/h (7 MPH) or more in order to turn ABS warning light off. Be sure to drive the vehicle and check that the warning light goes off.

Diagnostic Procedure with Diagnostic Trouble Code (DTC)

VEHICLE DYNAMICS CONTROL (VDC) (DIAGNOSTICS)

Brought to you by Eris Studios
 NOT FOR SALE

AF:DTC C0052 MOTOR AND MOTOR RELAY ON FAILURE

DTC DETECTING CONDITION:

- Defective motor relay
- Defective harness connector

TROUBLE SYMPTOM:

- ABS does not operate.
- VDC does not operate.
- EBD may not operate.

WIRING DIAGRAM:

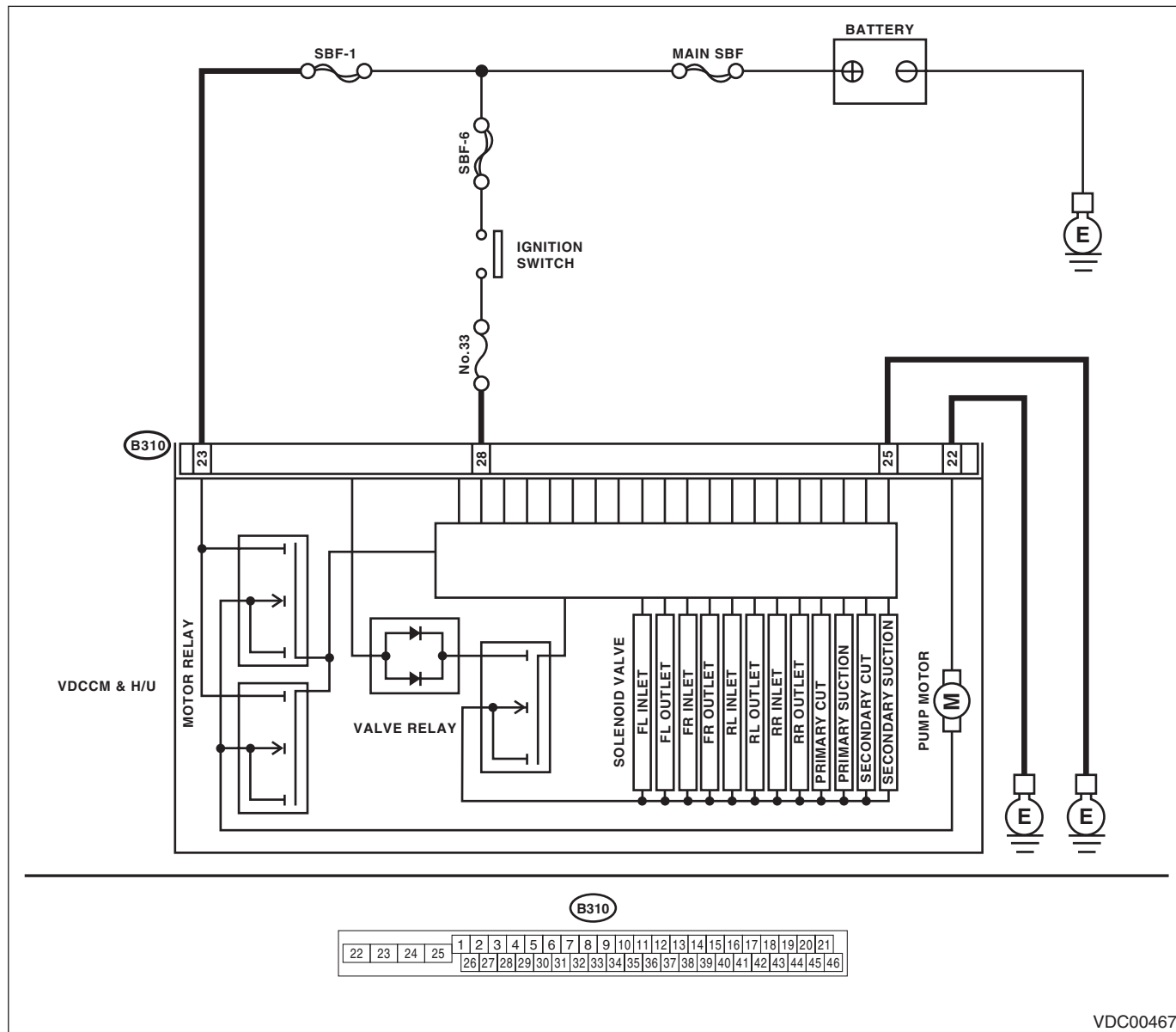

VDC00467

Diagnostic Procedure with Diagnostic Trouble Code (DTC)

VEHICLE DYNAMICS CONTROL (VDC) (DIAGNOSTICS)

Brought to you by Eris Studios
NOT FOR RESALE

Step	Check	Yes	No
1 CHECK VDCCM&H/U MOTOR RELAY. 1) Disconnect the connector from the VDCCM&H/U. 2) Measure the resistance between VDCCM&H/U connector terminals. Terminals No. 23 — No. 22:	Is the resistance 1 MΩ or more?	Go to step 2.	Replace the VDCCM&H/U. <Ref. to VDC-7, VDC Control Module and Hydraulic Control Unit (VDCCM&H/U).>
2 CHECK THE VDCCM&H/U. 1) Connect all connectors. 2) Erase the memory. 3) Perform the Inspection Mode. 4) Read the DTC.	Is the same DTC displayed?	Replace the VDCCM only. <Ref. to VDC-10, REPLACEMENT, VDC Control Module and Hydraulic Control Unit (VDCCM&H/U).>	Go to step 3.
3 CHECK OTHER DTC DETECTION.	Is any other DTC displayed?	Perform the diagnosis according to DTC. <Ref. to VDC(diag)-32, List of Diagnostic Trouble Code (DTC).>	Temporary poor contact occurs. NOTE: Though the ABS warning light remains on at this time, it is normal. Drive the vehicle at 12 km/h (7 MPH) or more in order to turn ABS warning light off. Be sure to drive the vehicle and check that the warning light goes off.

AG:DTC C0052 MOTOR MALFUNCTION

DTC DETECTING CONDITION:

- Defective motor
- Defective motor relay
- Defective harness connector

TROUBLE SYMPTOM:

- ABS does not operate.
- VDC does not operate.
- EBD may not operate.

NOTE:

For the diagnostic procedure, refer to DTC C0052 "MOTOR/MOTOR RELAY OFF FAILURE". <Ref. to VDC(diag)-63, DTC C0052 MOTOR AND MOTOR RELAY OFF FAILURE, Diagnostic Procedure with Diagnostic Trouble Code (DTC).>

Diagnostic Procedure with Diagnostic Trouble Code (DTC)

VEHICLE DYNAMICS CONTROL (VDC) (DIAGNOSTICS)

Brought to you by Eris Studios
NOT FOR SALE

AH:DTC C0054 BLS CIRCUIT OPEN

DTC DETECTING CONDITION:

Defective stop light switch

TROUBLE SYMPTOM:

- ABS does not operate.
- VDC does not operate.

WIRING DIAGRAM:

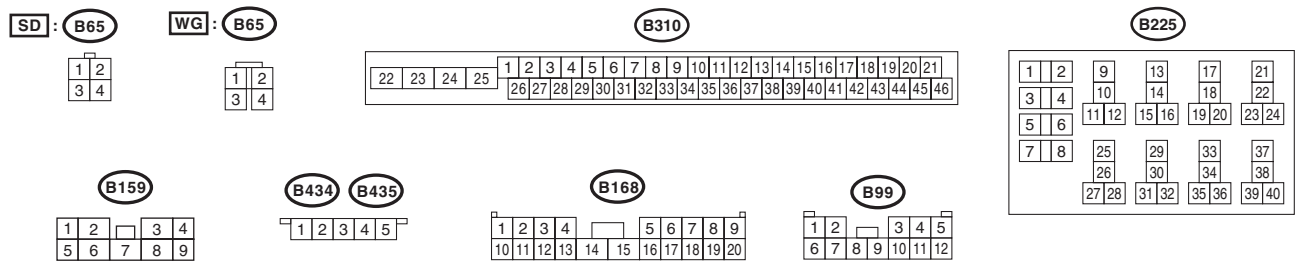
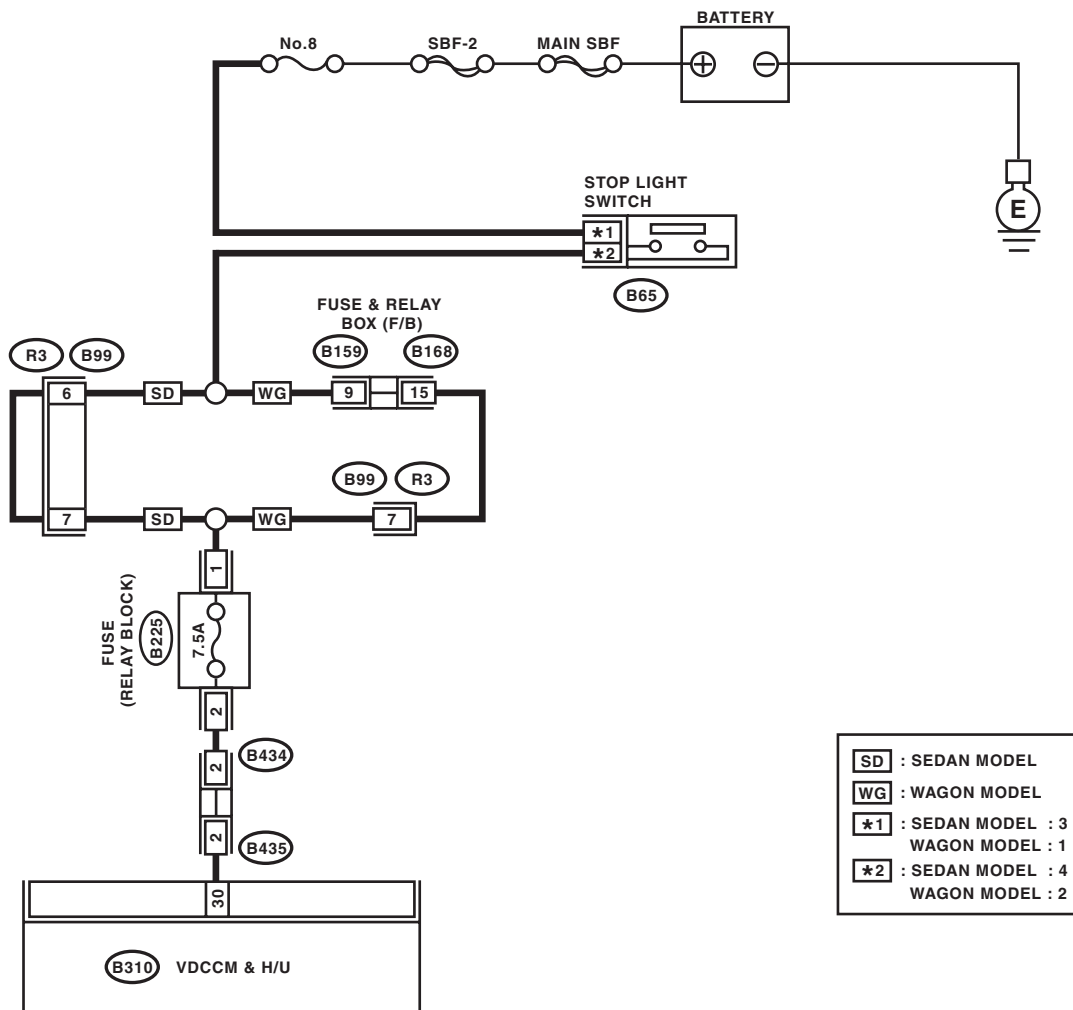

VDC00550

Diagnostic Procedure with Diagnostic Trouble Code (DTC)

VEHICLE DYNAMICS CONTROL (VDC) (DIAGNOSTICS)

Brought to you by Eris Studios
NOT FOR RESALE

Step	Check	Yes	No
1 CHECK OUTPUT OF STOP LIGHT SWITCH WITH SUBARU SELECT MONITOR. 1) Select {Current Data Display & Save} in Subaru Select Monitor. 2) Release the brake pedal. 3) Read the stop light switch output in Subaru Select Monitor.	Is OFF displayed on the display screen?	Go to step 2.	Go to step 3.
2 CHECK OUTPUT OF STOP LIGHT SWITCH WITH SUBARU SELECT MONITOR. 1) Depress the brake pedal. 2) Read the stop light switch output in Subaru Select Monitor.	Is ON displayed on the display screen?	Go to step 6.	Go to step 3.
3 CHECK IF STOP LIGHTS COME ON. Depress the brake pedal.	Does the stop light illuminate?	Go to step 4.	Repair the stop light circuit.
4 CHECK FUSE. Check the relay block fuse (B225).	Is the fuse OK?	Go to step 5.	Replace the fuse.
5 CHECK OPEN CIRCUIT OF HARNESS. 1) Turn the ignition switch to OFF. 2) Disconnect the connector from the VDCCM&H/U. 3) Depress the brake pedal. 4) Measure the voltage between VDCCM&H/U connector and chassis ground. Connector & terminal (B310) No. 30 (+) — Chassis ground (-):	Is the voltage 10 — 15 V?	Go to step 6.	Repair the harness between stop light switch and VDCCM&H/U connector.
6 CHECK POOR CONTACT IN CONNECTORS.	Is there poor contact in connector between stop light switch and VDCCM&H/U?	Repair the connector.	Go to step 7.
7 CHECK THE VDCCM&H/U. 1) Connect all connectors. 2) Erase the memory. 3) Perform the Inspection Mode. 4) Read the DTC.	Is the same DTC displayed?	Replace the VDCCM only. <Ref. to VDC-10, REPLACEMENT, VDC Control Module and Hydraulic Control Unit (VDCCM&H/U).>	Go to step 8.
8 CHECK OTHER DTC DETECTION.	Is any other DTC displayed?	Perform the diagnosis according to DTC.	Temporary poor contact occurs.

Diagnostic Procedure with Diagnostic Trouble Code (DTC)

VEHICLE DYNAMICS CONTROL (VDC) (DIAGNOSTICS)

Brought to you by Eris Studios
NOT FOR SALE

AI: DTC C0054 BLS ON MALFUNCTION

DTC DETECTING CONDITION:

Defective stop light switch

TROUBLE SYMPTOM:

- ABS does not operate.
- VDC does not operate.

WIRING DIAGRAM:

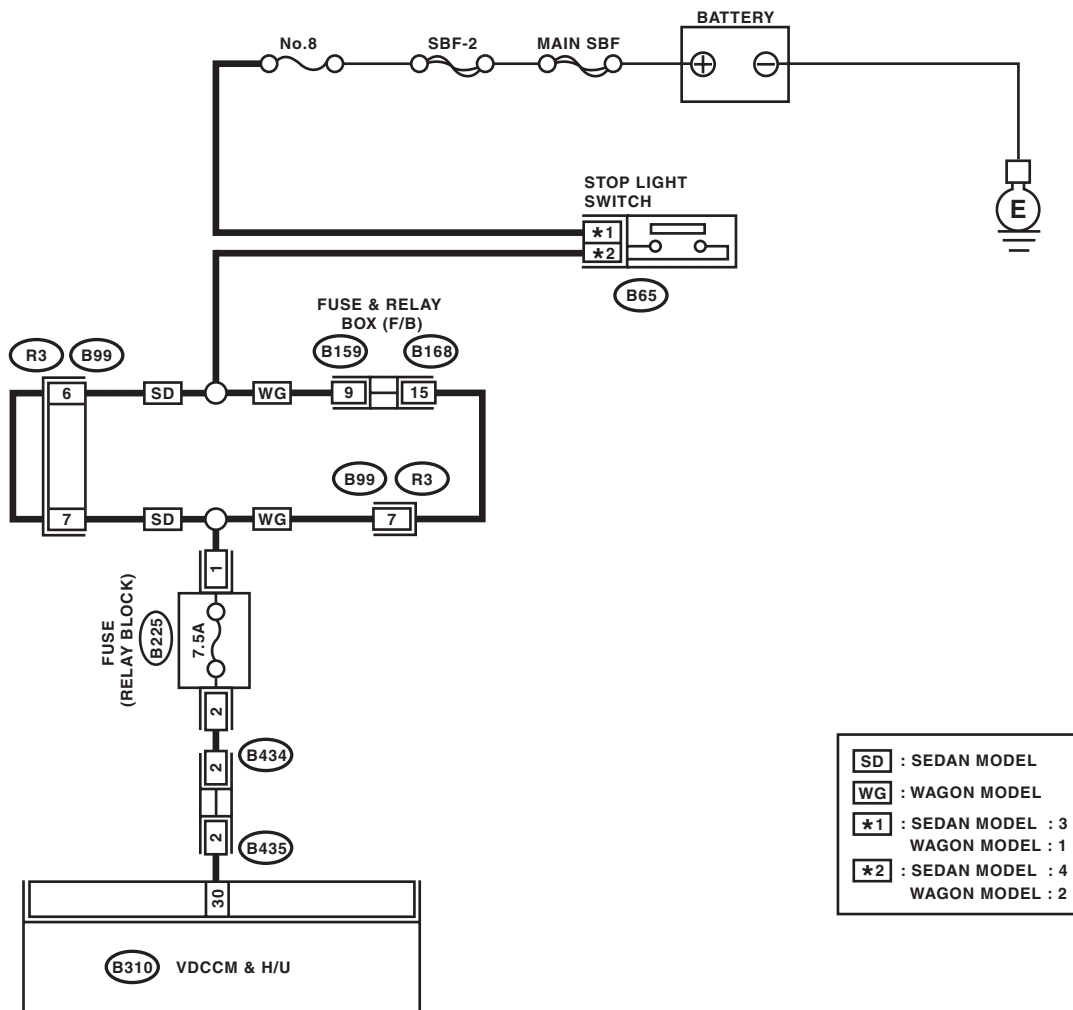

SD: B65



WG: B65



B310

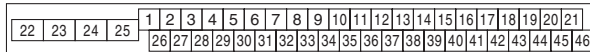

B225

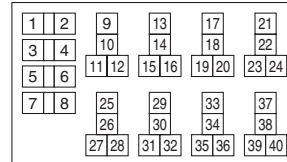

B159



B434 B435

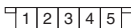

B168

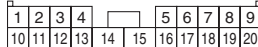

B99



VDC00550

Diagnostic Procedure with Diagnostic Trouble Code (DTC)

VEHICLE DYNAMICS CONTROL (VDC) (DIAGNOSTICS)

Brought to you by Eris Studios
NOT FOR RESALE

	Step	Check	Yes	No
1	CHECK STOP LIGHT SWITCH. 1) Turn the ignition switch to OFF. 2) Disconnect the stop light switch connector. 3) Measure the resistance of stop light switch terminals.	Is the resistance 1 MΩ or more when switch is OFF (when pedal is not depressed) ?	Go to step 2.	Replace the stop light switch.
2	INTERVIEWING CUSTOMERS. Make sure that the operation was performed in which accelerator pedal and brake pedal were depressed simultaneously (with depressing brake pedal with left foot).	Were the acceleration pedal and brake pedal depressed simultaneously?	System is normal. (DTC may be recorded while brake is applied during driving.)	Go to step 3.
3	CHECK THE VDCCM&H/U. 1) Connect all connectors. 2) Erase the memory. 3) Perform the Inspection Mode. 4) Read the DTC.	Is the same DTC displayed?	Replace the VDCCM only. <Ref. to VDC-10, REPLACEMENT, VDC Control Module and Hydraulic Control Unit (VDCCM&H/U).>	Go to step 4.
4	CHECK OTHER DTC DETECTION.	Is any other DTC displayed?	Perform the diagnosis according to DTC. <Ref. to VDC(diag)-32, List of Diagnostic Trouble Code (DTC).>	Temporary poor contact occurs.

Diagnostic Procedure with Diagnostic Trouble Code (DTC)

VEHICLE DYNAMICS CONTROL (VDC) (DIAGNOSTICS)

Brought to you by Eris Studios
NOT FOR SALE

AJ:DTC C0054 BLS OFF MALFUNCTION

DTC DETECTING CONDITION:

Defective stop light switch

TROUBLE SYMPTOM:

- ABS does not operate.
- VDC does not operate.

WIRING DIAGRAM:

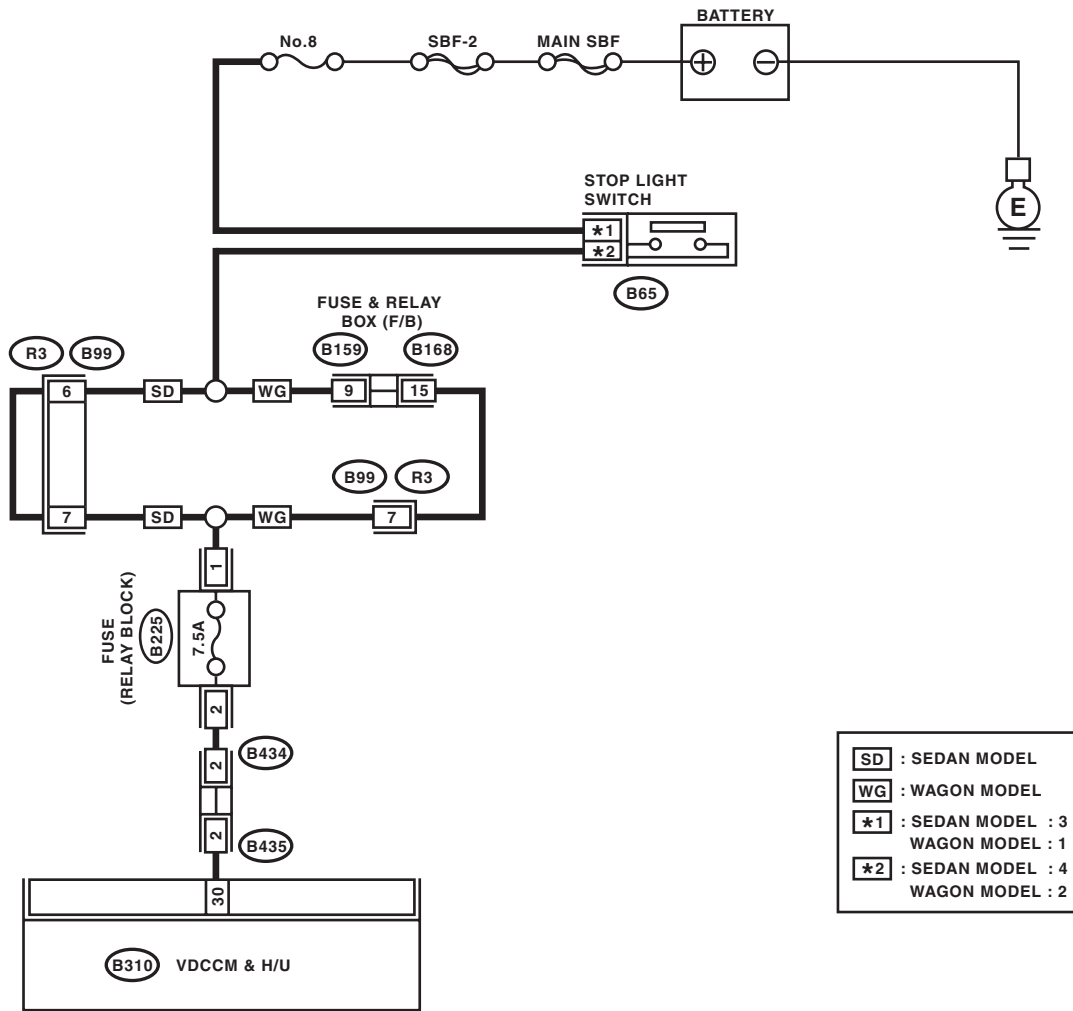

SD	: SEDAN MODEL
WG	: WAGON MODEL
*1	: SEDAN MODEL : 3 WAGON MODEL : 1
*2	: SEDAN MODEL : 4 WAGON MODEL : 2

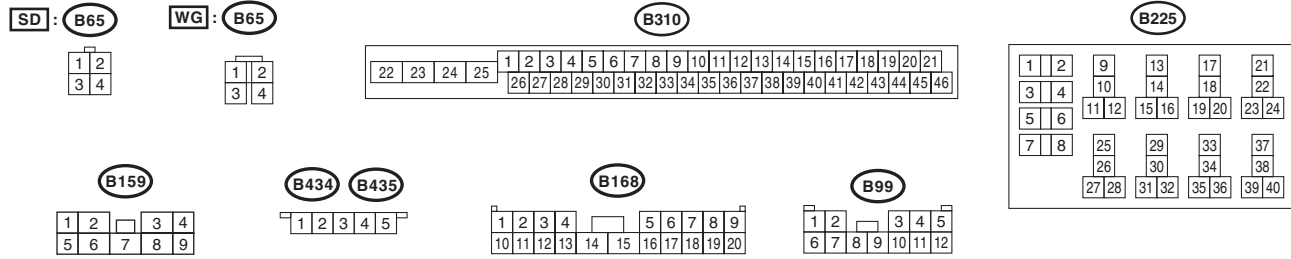

VDC00550

Diagnostic Procedure with Diagnostic Trouble Code (DTC)

VEHICLE DYNAMICS CONTROL (VDC) (DIAGNOSTICS)

Brought to you by Eris Studios
NOT FOR RESALE

Step	Check	Yes	No
1 CHECK STOP LIGHT SWITCH. 1) Turn the ignition switch to OFF. 2) Disconnect the stop light switch connector. 3) Measure the resistance of stop light switch terminals.	Is the resistance 0.5 M Ω or less when the switch is ON (when pedal is depressed) ?	Go to step 2.	Replace the stop light switch.
2 CHECK POWER SUPPLY OF STOP LIGHT SWITCH. Measure the voltage between the stop light switch terminal and chassis ground. Connector & terminal <i>Sedan model</i> (B65) No. 3 (+) — Chassis ground (-): <i>Wagon model</i> (B65) No. 1 (+) — Chassis ground (-):	Is the voltage 10 — 15 V?	Go to step 3.	Repair the power supply circuit of stop light.
3 CHECK STOP LIGHT SWITCH HARNESS. 1) Disconnect the connector from the VDCCM&H/U. 2) Measure the resistance between VDCCM&H/U and stop light switch. Connector & terminal <i>Sedan model</i> (B65) No. 4 — (B310) No. 30: <i>Wagon model</i> (B65) No. 2 — (B310) No. 30:	Is the resistance less than 0.5 Ω ?	Go to step 4.	Repair the stop light switch circuit.
4 CHECK POOR CONTACT IN CONNECTORS.	Is there poor contact in connector between stop light switch and VDCCM&H/U?	Repair the connector.	Go to step 5.
5 CHECK THE VDCCM&H/U. 1) Connect all connectors. 2) Erase the memory. 3) Perform the Inspection Mode. 4) Read the DTC.	Is the same DTC displayed?	Replace the VDCCM only. <Ref. to VDC-10, REPLACEMENT, VDC Control Module and Hydraulic Control Unit (VDCCM&H/U).>	Go to step 6.
6 CHECK OTHER DTC DETECTION.	Is any other DTC displayed?	Perform the diagnosis according to DTC.	Temporary poor contact occurs.

Diagnostic Procedure with Diagnostic Trouble Code (DTC)

VEHICLE DYNAMICS CONTROL (VDC) (DIAGNOSTICS)

Brought to you by Eris Studios
NOT FOR SALE

AK:DTC C0056 G SENSOR SIGNAL

DTC DETECTING CONDITION:

Defective longitudinal G sensor

Trouble symptom:

Hill start assist does not operate.

WIRING DIAGRAM:

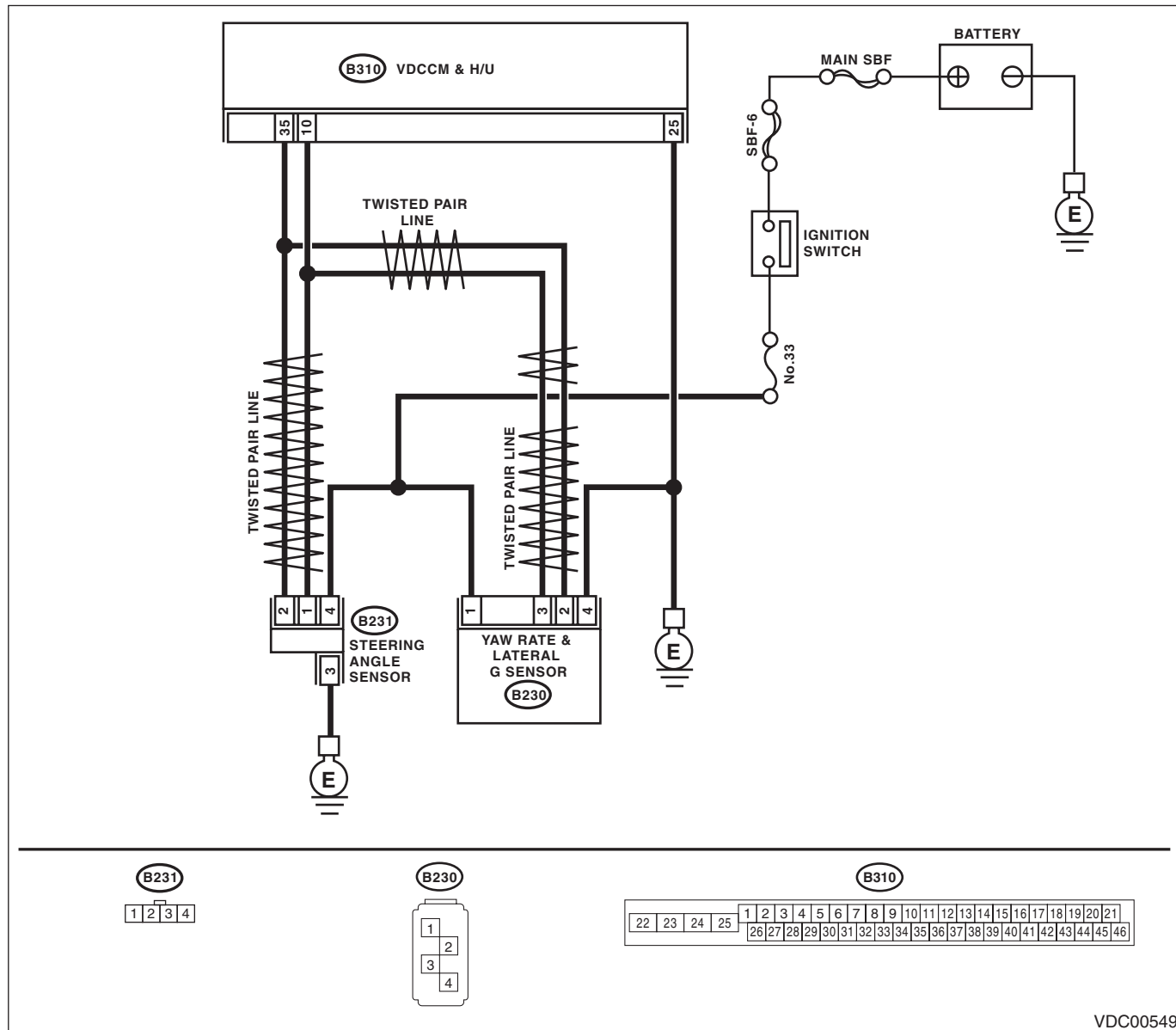

VDC00549

Diagnostic Procedure with Diagnostic Trouble Code (DTC)

VEHICLE DYNAMICS CONTROL (VDC) (DIAGNOSTICS)

Brought to you by Eris Studios
NOT FOR RESALE

Step	Check	Yes	No
1 WHETHER A WHEEL TURNED FREELY OR NOT. Check if the wheels have been turned freely for one minute or more, such as when the vehicle is jacked-up, under full-lock cornering or when the wheels are not in contact with road surface.	Did the wheels turn freely?	VDC is normal. Erase the memory.	Go to step 2.
2 CHECK OUTPUT OF LONGITUDINAL G SENSOR USING SUBARU SELECT MONITOR. 1) Park the vehicle on a level surface. 2) Select {Current Data Display & Save} in Subaru Select Monitor. 3) Read the display for the longitudinal G sensor output.	Is the indicated reading on the monitor display $-1.2 \text{ — } 1.2 \text{ m/s}^2$?	Go to step 3.	Replace the yaw rate & lateral G sensor.
3 CHECK OUTPUT OF LONGITUDINAL G SENSOR USING SUBARU SELECT MONITOR. 1) Turn the ignition switch to OFF. 2) Remove the yaw rate & lateral G sensor from vehicle. 3) Turn the ignition switch to ON, and select {Current Data Display & Save} in Subaru Select Monitor. 4) Read the display for the longitudinal G sensor output.	When the yaw rate & lateral G sensor is inclined forward by 90° , is the indicated value $6.8 \text{ — } 12.8 \text{ m/s}^2$?	Go to step 4.	Replace the yaw rate & lateral G sensor.
4 CHECK OUTPUT OF LONGITUDINAL G SENSOR USING SUBARU SELECT MONITOR. Read the display for the longitudinal G sensor output.	When the yaw rate & lateral G sensor is inclined backward by 90° , is the indicated value $-6.8 \text{ — } -12.8 \text{ m/s}^2$?	Go to step 5.	Replace the yaw rate & lateral G sensor.
5 CHECK POOR CONTACT OF CONNECTORS. Turn the ignition switch to OFF.	Is there poor contact in connector between VDCCM& H/U and yaw rate & lateral G sensor?	Repair the connector.	Go to step 6.
6 CHECK THE VDCCM&H/U. 1) Connect all connectors. 2) Erase the memory. 3) Perform the Inspection Mode. 4) Read the DTC.	Is the same DTC displayed?	Replace the VDCCM only. <Ref. to VDC-10, REPLACEMENT, VDC Control Module and Hydraulic Control Unit (VDCCM&H/U).>	Go to step 7.
7 CHECK OTHER DTC DETECTION.	Is any other DTC displayed?	Perform the diagnosis according to DTC.	Temporary poor contact occurs.

Diagnostic Procedure with Diagnostic Trouble Code (DTC)

VEHICLE DYNAMICS CONTROL (VDC) (DIAGNOSTICS)

Brought to you by Eris Studios
NOT FOR SALE

AL:DTC C0057 ECM COMMUNICATION CIRCUIT

DTC DETECTING CONDITION:

No CAN signal from ECM.

TROUBLE SYMPTOM:

- ABS does not operate.
- VDC does not operate.

Step	Check	Yes	No	
1	CHECK LAN SYSTEM. Perform the diagnosis for LAN system. <Ref. to LAN(diag)-29, OPERATION, Read Diagnostic Trouble Code (DTC).>	Is there any fault in LAN system?	Perform the diagnosis according to DTC for LAN system.	Go to step 2.
2	CHECK POOR CONTACT IN CONNECTORS.	Is there poor contact in ECM connector?	Repair the connector.	Go to step 3.
3	CHECK ECM.	Is ECM normal?	Go to step 4.	Replace the ECM.
4	CHECK THE VDCCM&H/U. 1) Connect all connectors. 2) Erase the memory. 3) Perform the Inspection Mode. 4) Read the DTC.	Is the same DTC displayed?	Replace the VDCCM only. <Ref. to VDC-10, REPLACEMENT, VDC Control Module and Hydraulic Control Unit (VDCCM&H/U).>	Go to step 5.
5	CHECK OTHER DTC DETECTION.	Is any other DTC displayed?	Perform the diagnosis according to DTC.	It results from a temporary noise interference.

Diagnostic Procedure with Diagnostic Trouble Code (DTC)

VEHICLE DYNAMICS CONTROL (VDC) (DIAGNOSTICS)

Brought to you by Eris Studios
NOT FOR RESALE

AM:DTC C0057 ECM CONTROL SYSTEM

DTC DETECTING CONDITION:

ECM coordinate control prohibition

TROUBLE SYMPTOM:

- ABS does not operate.
- VDC does not operate.

NOTE:

Warning lights go off if ECM coordinate control is recovered.

Step	Check	Yes	No	
1	CHECK WARNING LIGHT. Check whether the VDC warning light illuminates after driving for more than 1 minute at a speed of 10 km/h or more.	Does the VDC warning light illuminate?	Go to step 2.	VDC is normal. Perform the Clear Memory Mode. NOTE: If cranking operation is performed while driving, DTC may be memorized.
2	CHECK POOR CONTACT IN CONNECTORS.	Is there poor contact in ECM connector?	Repair the connector.	Go to step 3.
3	CHECK ECM.	Is ECM normal?	Go to step 4.	Replace the ECM.
4	CHECK THE VDCCM&H/U. 1) Connect all connectors. 2) Perform the Clear Memory Mode. 3) Perform the Inspection Mode. 4) Read the DTC.	Is the same DTC displayed?	Replace the VDCCM only. <Ref. to VDC-10, REPLACEMENT, VDC Control Module and Hydraulic Control Unit (VDCCM&H/U).>	Go to step 5.
5	CHECK OTHER DTC DETECTION.	Is any other DTC displayed?	Perform the diagnosis according to DTC.	It results from a temporary noise interference.

Diagnostic Procedure with Diagnostic Trouble Code (DTC)

VEHICLE DYNAMICS CONTROL (VDC) (DIAGNOSTICS)

Brought to you by Eris Studios
NOT FOR SALE

AN:DTC C0071 STEERING ANGLE SENSOR OFFSET IS TOO BIG

DTC DETECTING CONDITION:

Defective steering angle sensor

TROUBLE SYMPTOM:

VDC does not operate.

WIRING DIAGRAM:

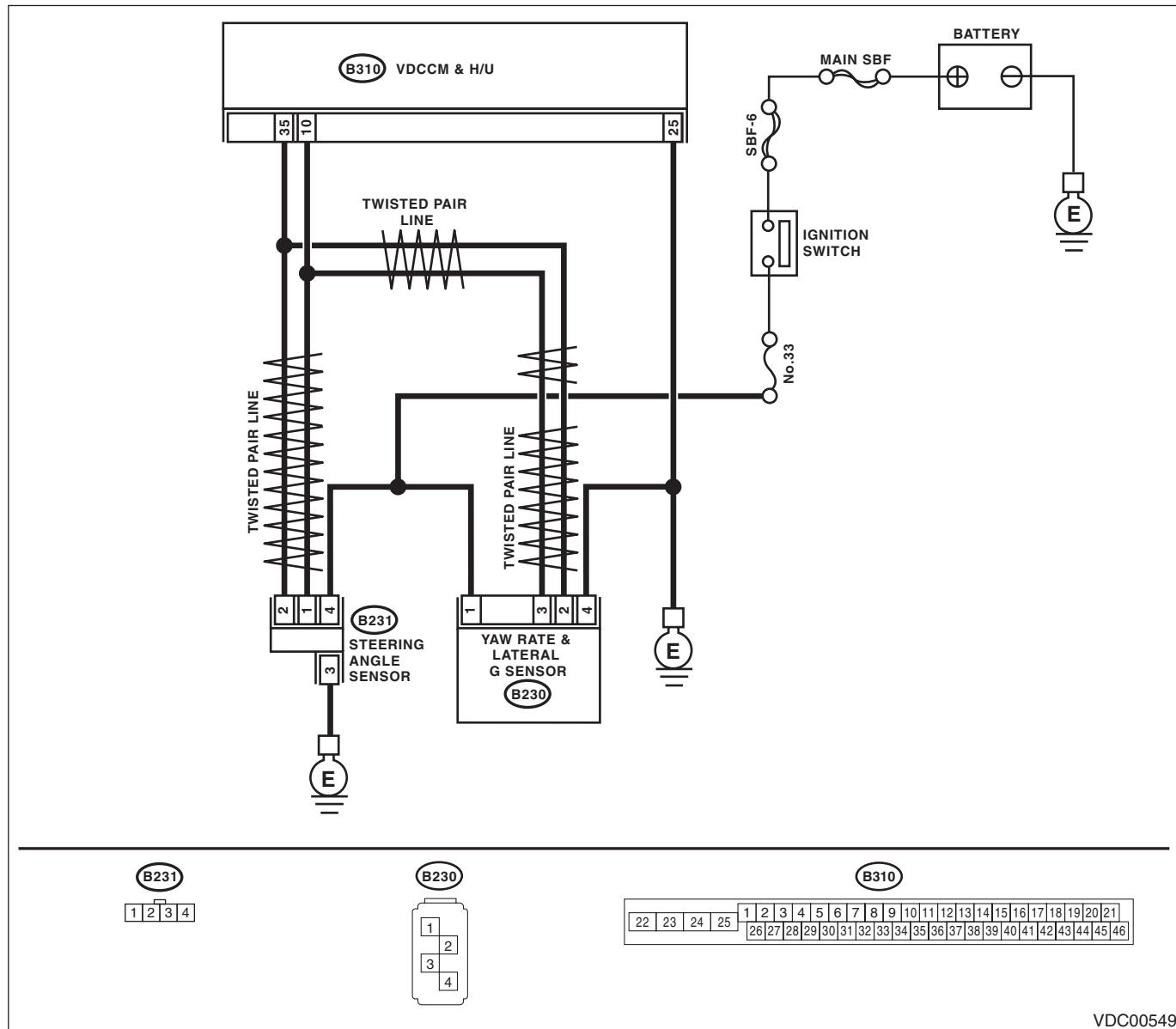

VDC00549

Diagnostic Procedure with Diagnostic Trouble Code (DTC)

VEHICLE DYNAMICS CONTROL (VDC) (DIAGNOSTICS)

Brought to you by Eris Studios
NOT FOR RESALE

	Step	Check	Yes	No
1	CHECK STEERING WHEEL. 1) Drive the vehicle on a flat road. 2) Park the vehicle straight. 3) Check the steering wheel for deviation from center.	Is the deviation from the center of steering wheel less than 5°?	Go to step 2.	Perform the centering adjustment of steering wheel.
2	CHECK THE VDCCM&H/U. 1) Turn the ignition switch to OFF. 2) Connect all connectors. 3) Erase the memory. 4) Perform the Inspection Mode. 5) Read the DTC.	Is the same DTC displayed?	Replace the VDCCM only. <Ref. to VDC-10, REPLACEMENT, VDC Control Module and Hydraulic Control Unit (VDCCM&H/U).>	Go to step 3.
3	CHECK OTHER DTC DETECTION.	Is any other DTC displayed?	Perform the diagnosis according to DTC. <Ref. to VDC(diag)-32, List of Diagnostic Trouble Code (DTC).>	Temporary poor contact occurs.

Diagnostic Procedure with Diagnostic Trouble Code (DTC)

VEHICLE DYNAMICS CONTROL (VDC) (DIAGNOSTICS)

Brought to you by Eris Studios
NOT FOR SALE

AO:DTC C0071 CHANGE RANGE OF STEERING ANGLE SENSOR IS TOO BIG

DTC DETECTING CONDITION:

Defective steering angle sensor

TROUBLE SYMPTOM:

VDC does not operate.

WIRING DIAGRAM:

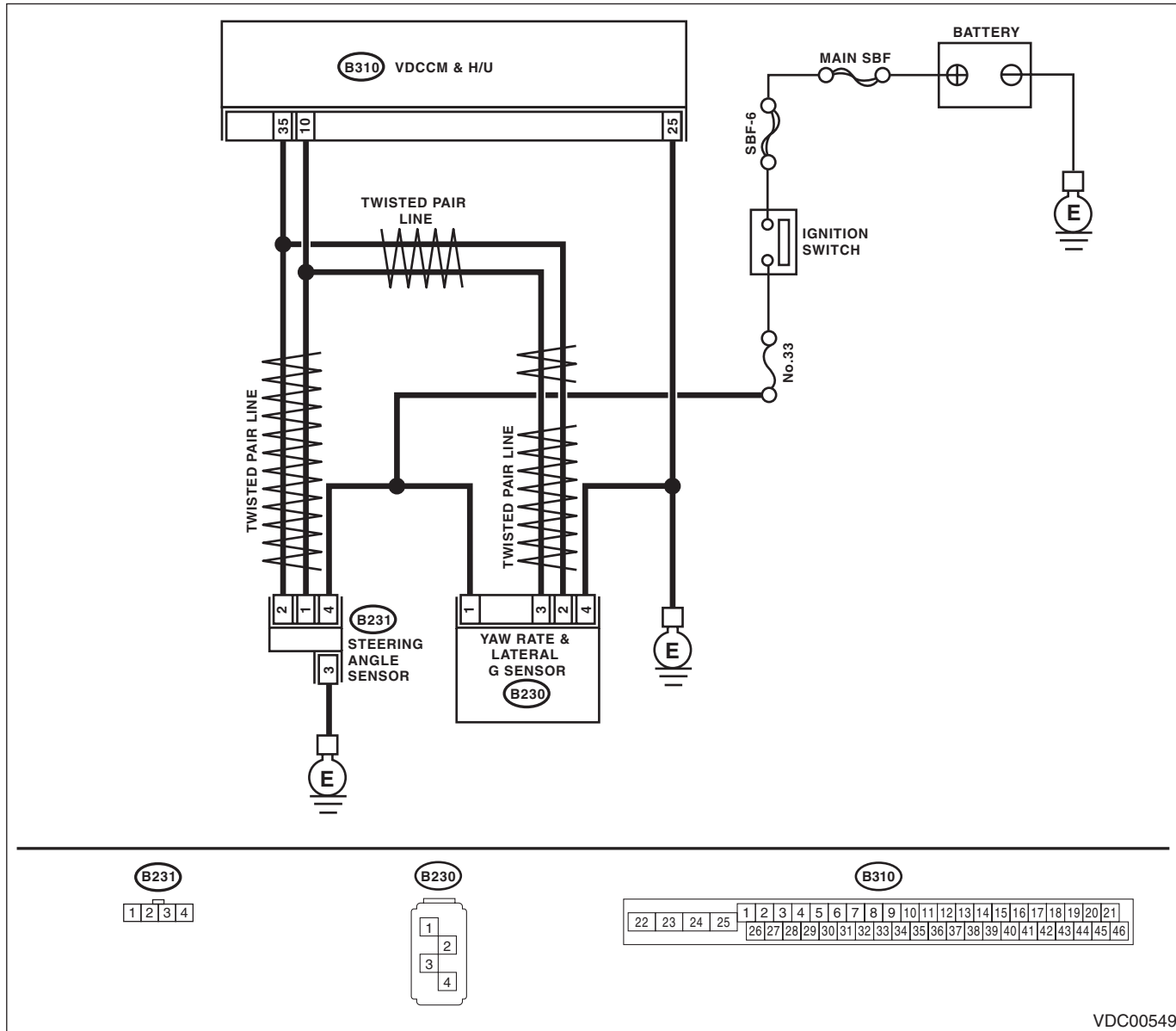

VDC00549

Diagnostic Procedure with Diagnostic Trouble Code (DTC)

VEHICLE DYNAMICS CONTROL (VDC) (DIAGNOSTICS)

Brought to you by Eris Studios
NOT FOR RESALE

	Step	Check	Yes	No
1	CHECK THE VDCCM&H/U. 1) Turn the ignition switch to OFF. 2) Connect all connectors. 3) Erase the memory. 4) Perform the Inspection Mode. 5) Read the DTC.	Is the same DTC displayed?	Replace the VDCCM only. <Ref. to VDC-10, REPLACEMENT, VDC Control Module and Hydraulic Control Unit (VDCCM&H/U).>	Go to step 2.
2	CHECK OTHER DTC DETECTION.	Is any other DTC displayed?	Perform the diagnosis according to DTC. <Ref. to VDC(diag)-32, List of Diagnostic Trouble Code (DTC).>	Temporary poor contact occurs.

Diagnostic Procedure with Diagnostic Trouble Code (DTC)

VEHICLE DYNAMICS CONTROL (VDC) (DIAGNOSTICS)

Brought to you by Eris Studios
NOT FOR SALE

AP:DTC C0071 STEERING ANGLE SENSOR MALFUNCTION

DTC DETECTING CONDITION:

Signal does not come from steering angle sensor.

TROUBLE SYMPTOM:

VDC does not operate.

WIRING DIAGRAM:

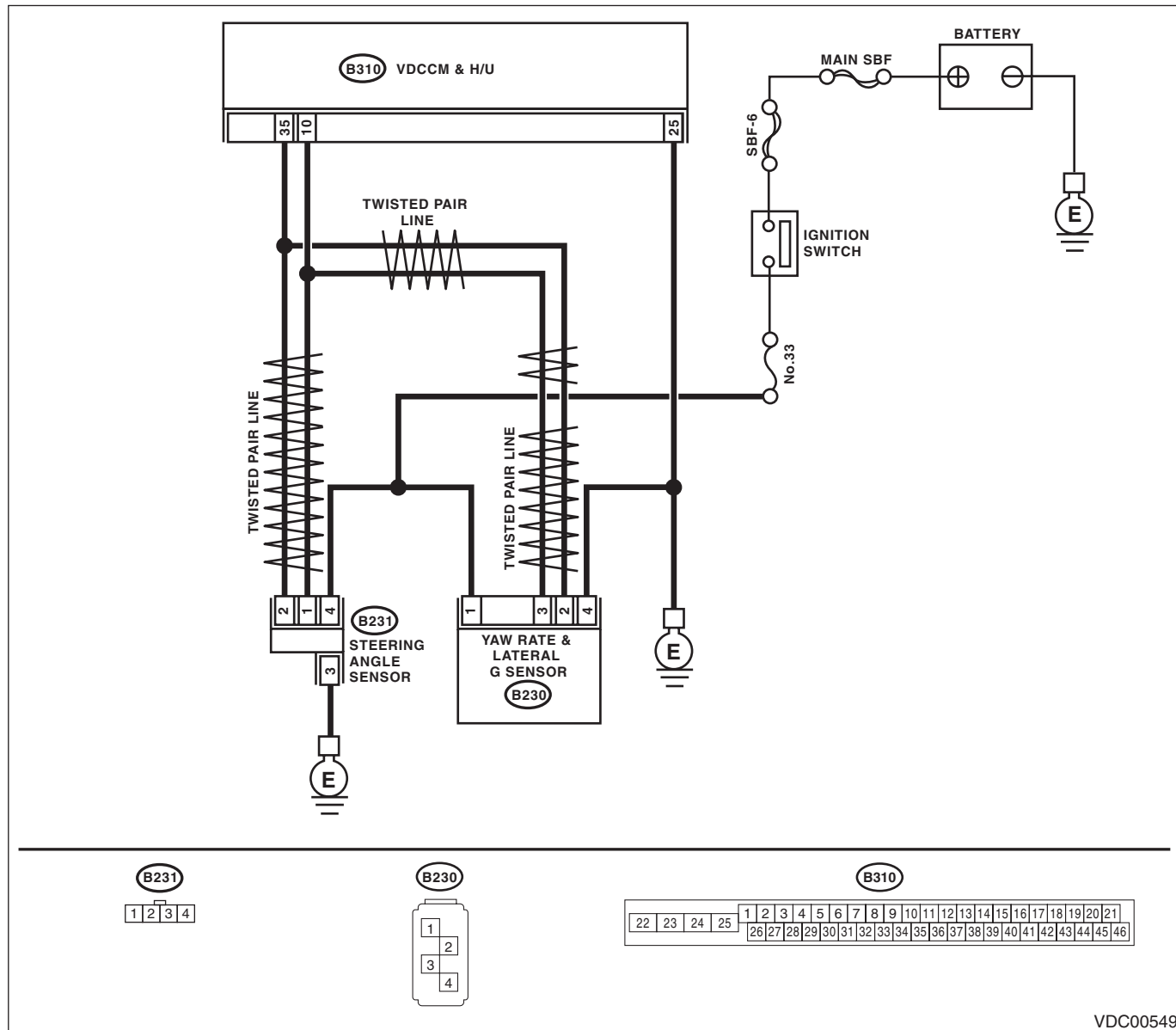

VDC00549

Diagnostic Procedure with Diagnostic Trouble Code (DTC)

VEHICLE DYNAMICS CONTROL (VDC) (DIAGNOSTICS)

Brought to you by Eris Studios
NOT FOR RESALE

Step	Check	Yes	No
1 CHECK POWER SUPPLY FOR STEERING ANGLE SENSOR. 1) Turn the ignition switch to OFF. 2) Disconnect the connector from steering angle sensor. 3) Turn the ignition switch to ON. 4) Measure the voltage between the steering angle sensor and chassis ground. Connector & terminal (B231) No. 4 (+) — Chassis ground (-):	Is the voltage 10 — 15 V?	Go to step 2.	Repair the power supply circuit of steering angle sensor.
2 CHECK GROUND CIRCUIT OF STEERING ANGLE SENSOR. Measure the resistance between steering angle sensor and chassis ground. Connector & terminal (B231) No. 3 — Chassis ground:	Is the resistance less than 0.5 Ω?	Go to step 3.	Repair ground circuit in the steering angle sensor.
3 CHECK STEERING ANGLE SENSOR HARNESS. 1) Disconnect the connector from the VDCCM&H/U. 2) Measure the resistance between VDCCM&H/U and steering angle sensor. Connector & terminal (B231) No. 1 — (B310) No. 10: (B231) No. 2 — (B310) No. 35:	Is the resistance less than 0.5 Ω?	Go to step 4.	Repair the harness between the steering angle sensor and VDCCM&H/U.
4 CHECK GROUND SHORT CIRCUIT OF STEERING ANGLE SENSOR HARNESS. Measure the resistance between steering angle sensor and chassis ground. Connector & terminal (B231) No. 1 — Chassis ground: (B231) No. 2 — Chassis ground:	Is the resistance 1 MΩ or more?	Go to step 5.	Repair the harness between the steering angle sensor and VDCCM&H/U.
5 CHECK STEERING ANGLE SENSOR. 1) Turn the ignition switch to OFF. 2) Connect all connectors. 3) Erase the memory. 4) Perform the Inspection Mode. 5) Read the DTC.	Is the same DTC displayed?	Go to step 6.	Go to step 7.
6 CHECK THE VDCCM&H/U. 1) Turn the ignition switch to OFF. 2) Replace the steering angle sensor. 3) Erase the memory. 4) Perform the Inspection Mode. 5) Read the DTC.	Is the same DTC displayed?	Replace the VDCCM only. <Ref. to VDC-10, REPLACEMENT, VDC Control Module and Hydraulic Control Unit (VDCCM&H/U).>	Go to step 8.
7 CHECK OTHER DTC DETECTION.	Is any other DTC displayed?	Perform the diagnosis according to DTC.	Temporary poor contact occurs.
8 CHECK OTHER DTC DETECTION.	Is any other DTC displayed?	Perform the diagnosis according to DTC.	Original steering angle sensor malfunction

Diagnostic Procedure with Diagnostic Trouble Code (DTC)

VEHICLE DYNAMICS CONTROL (VDC) (DIAGNOSTICS)

Brought to you by Eris Studios
NOT FOR SALE

AQ:DTC C0071 STEERING ANGLE SENSOR MALFUNCTION

DTC DETECTING CONDITION:

Defective steering angle sensor

TROUBLE SYMPTOM:

- ABS does not operate.
- VDC does not operate.

NOTE:

- Warning light does not illuminate though problem is detected.
- The ABS and VDC operate normally if voltage returns.

WIRING DIAGRAM:

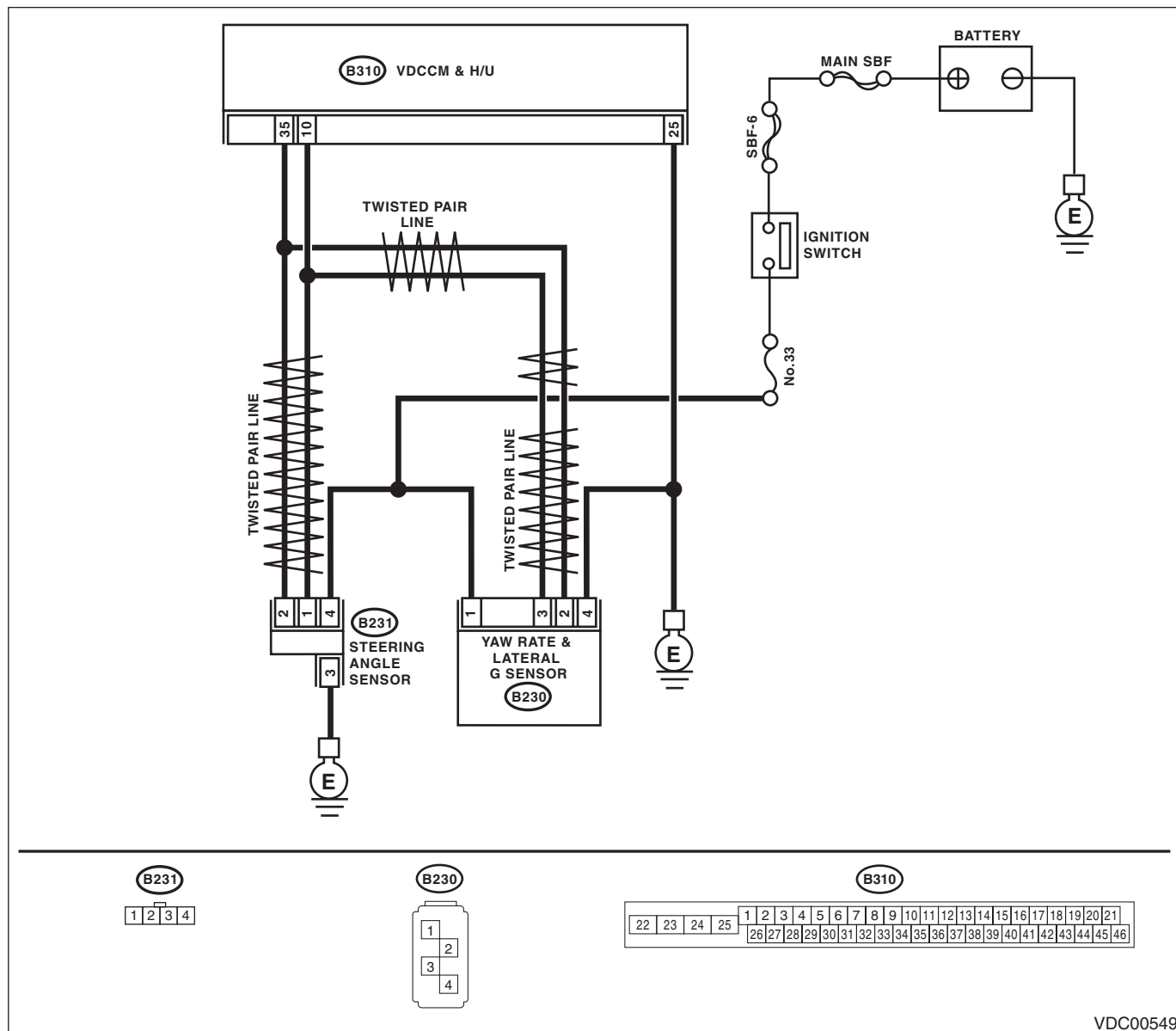

VDC00549

Diagnostic Procedure with Diagnostic Trouble Code (DTC)

VEHICLE DYNAMICS CONTROL (VDC) (DIAGNOSTICS)

Brought to you by Eris Studios
NOT FOR RESALE

Step	Check	Yes	No
1 CHECK POWER SUPPLY FOR STEERING ANGLE SENSOR. 1) Turn the ignition switch to OFF. 2) Disconnect the connector from steering angle sensor. 3) Turn the ignition switch to ON. 4) Measure the voltage between the steering angle sensor and chassis ground. Connector & terminal (B231) No. 4 (+) — Chassis ground (-):	Is the voltage 10 — 15 V?	Go to step 2.	Repair the power supply circuit of steering angle sensor.
2 CHECK GROUND CIRCUIT OF STEERING ANGLE SENSOR. Measure the resistance between steering angle sensor and chassis ground. Connector & terminal (B231) No. 3 — Chassis ground:	Is the resistance less than 0.5 Ω?	Go to step 3.	Repair ground circuit in the steering angle sensor.
3 CHECK STEERING ANGLE SENSOR. 1) Turn the ignition switch to OFF. 2) Connect all connectors. 3) Erase the memory. 4) Perform the Inspection Mode. 5) Read the DTC.	Is the same DTC displayed?	Go to step 4.	Go to step 5.
4 CHECK THE VDCCM&H/U. 1) Turn the ignition switch to OFF. 2) Replace the steering angle sensor. 3) Erase the memory. 4) Perform the Inspection Mode. 5) Read the DTC.	Is the same DTC displayed?	Replace the VDCCM only. <Ref. to VDC-10, REPLACEMENT, VDC Control Module and Hydraulic Control Unit (VDCCM&H/U).>	Go to step 6.
5 CHECK OTHER DTC DETECTION.	Is any other DTC displayed?	Perform the diagnosis according to DTC.	Temporary poor contact occurs.
6 CHECK OTHER DTC DETECTION.	Is any other DTC displayed?	Perform the diagnosis according to DTC.	Original steering angle sensor malfunction

Diagnostic Procedure with Diagnostic Trouble Code (DTC)

VEHICLE DYNAMICS CONTROL (VDC) (DIAGNOSTICS)

Brought to you by Eris Studios
NOT FOR SALE

AR:DTC C0072 ABNORMAL YAW RATE SENSOR OUTPUT

DTC DETECTING CONDITION:

Defective yaw rate sensor

TROUBLE SYMPTOM:

VDC does not operate.

WIRING DIAGRAM:

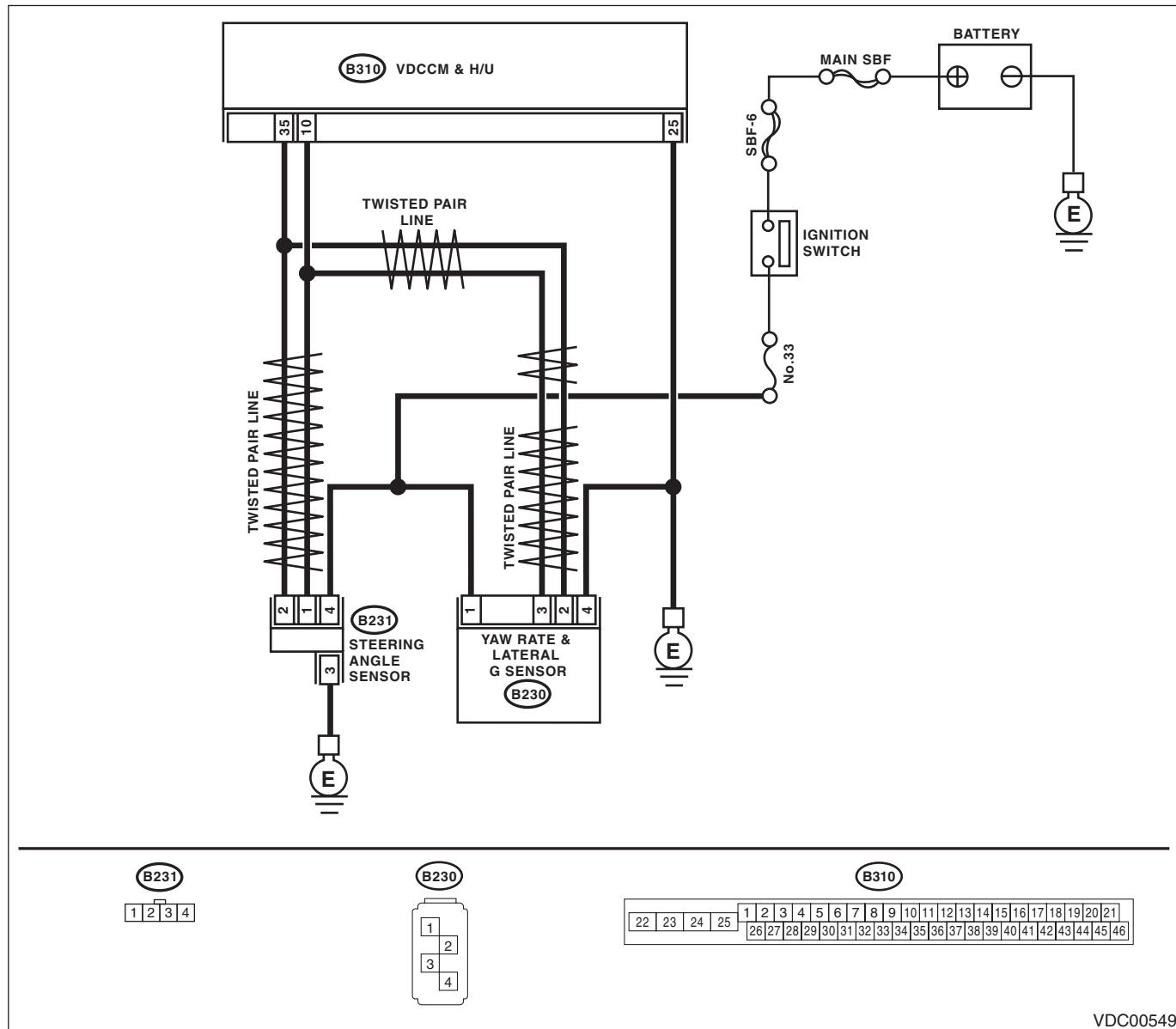

VDC00549

Diagnostic Procedure with Diagnostic Trouble Code (DTC)

VEHICLE DYNAMICS CONTROL (VDC) (DIAGNOSTICS)

Brought to you by Eris Studios
NOT FOR RESALE

	Step	Check	Yes	No
1	CHECK DRIVING PLACE. Check if the vehicle ran the road with banks or sandy surface (which does not mean a dirt road).	Did the vehicle run the road with banks or sandy surface (which does not mean a dirt road) ?	VDCCM&H/U may record DTC when the vehicle ran the road with banks or sandy surface (which does not mean a dirt road).	Go to step 2.
2	CHECK YAW RATE & LATERAL G SENSOR INSTALLATION.	Is the yaw rate & lateral G sensor installation bolt tightened to 7.5 N·m (0.76 kgf·m, 5.5 ft·lb)?	Go to step 3.	Tighten the yaw rate & lateral G sensor installation bolt.
3	CHECK OUTPUT OF YAW RATE & LATERAL G SENSOR WITH SUBARU SELECT MONITOR. 1) Drive the vehicle on a flat road. 2) Park the vehicle straight. 3) Select {Current Data Display & Save} in Subaru Select Monitor. 4) Read the yaw rate output displayed on display.	Is the reading indicated on monitor display -4 — 4 deg/s?	Go to step 4.	Replace the yaw rate & lateral G sensor.
4	CHECK OUTPUT OF STEERING ANGLE SENSOR WITH SUBARU SELECT MONITOR. 1) Drive the vehicle on a flat road. 2) Park the vehicle straight. 3) Select {Current Data Display & Save} in Subaru Select Monitor. 4) Read the steering angle sensor output displayed on display.	Is the reading indicated on monitor display -5 — 5°?	Go to step 5.	Perform the centering adjustment of steering wheel.
5	CHECK YAW RATE & LATERAL G SENSOR. 1) Turn the ignition switch to OFF. 2) Connect all connectors. 3) Erase the memory. 4) Perform the Inspection Mode. 5) Read the DTC.	Is the same DTC displayed?	Go to step 6.	Go to step 7.
6	CHECK THE VDCCM&H/U. 1) Turn the ignition switch to OFF. 2) Replace the yaw rate & lateral G sensor. 3) Erase the memory. 4) Perform the Inspection Mode. 5) Read the DTC.	Is the same DTC displayed?	Replace the VDCCM only. <Ref. to VDC-10, REPLACEMENT, VDC Control Module and Hydraulic Control Unit (VDCCM&H/U).>	Go to step 8.
7	CHECK OTHER DTC DETECTION.	Is any other DTC displayed?	Perform the diagnosis according to DTC.	Temporary poor contact occurs.
8	CHECK OTHER DTC DETECTION.	Is any other DTC displayed?	Perform the diagnosis according to DTC.	Malfunction is found in original yaw rate & lateral G sensor.

Diagnostic Procedure with Diagnostic Trouble Code (DTC)

VEHICLE DYNAMICS CONTROL (VDC) (DIAGNOSTICS)

Brought to you by Eris Studios
NOT FOR SALE

AS:DTC C0072 VOLTAGE INPUTTED TO YAW RATE SENSOR EXCEEDS SPECIFICATION

DTC DETECTING CONDITION:

Defective yaw rate sensor

TROUBLE SYMPTOM:

VDC does not operate.

WIRING DIAGRAM:

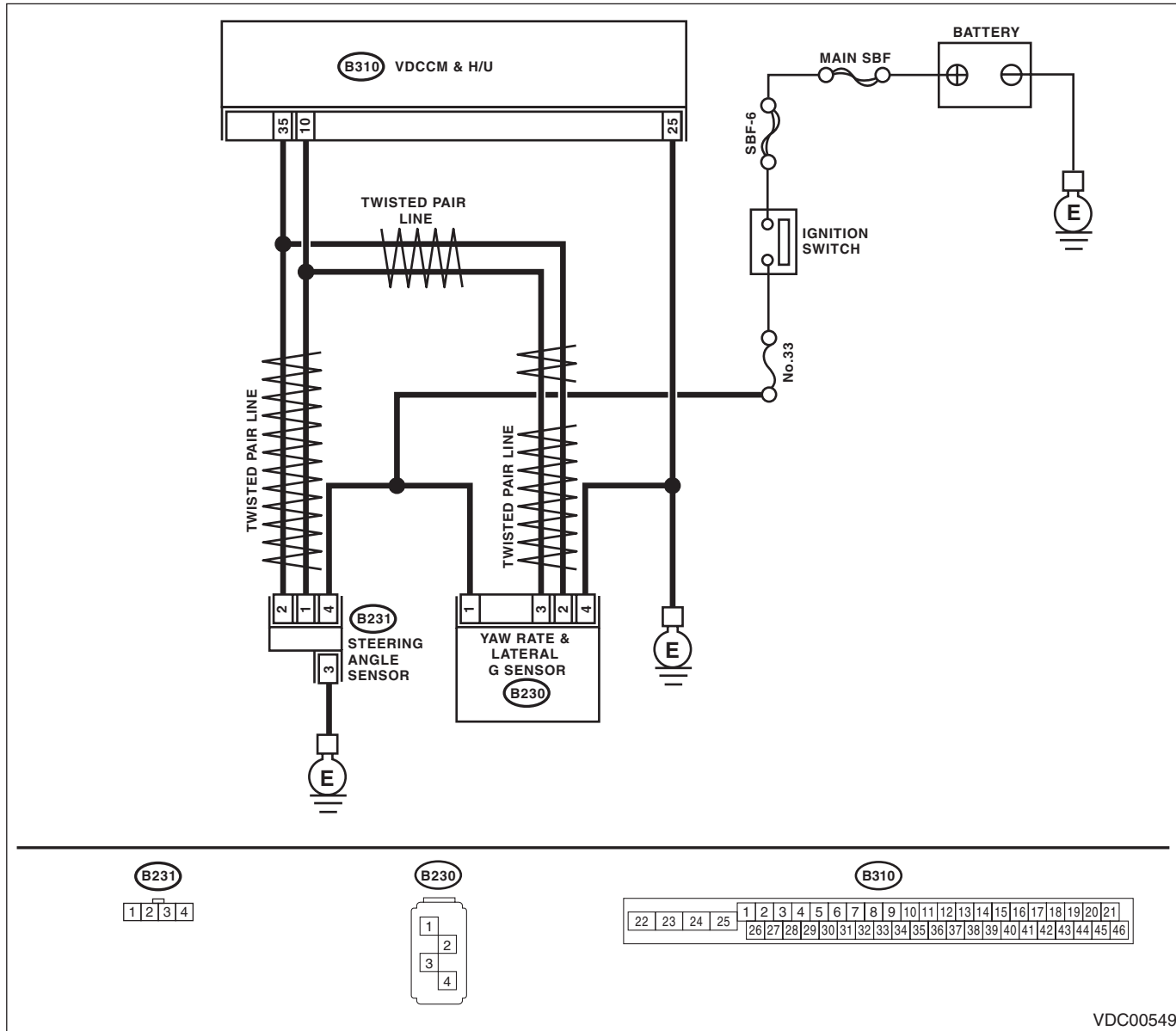

VDC00549

Diagnostic Procedure with Diagnostic Trouble Code (DTC)

VEHICLE DYNAMICS CONTROL (VDC) (DIAGNOSTICS)

Brought to you by Eris Studios
NOT FOR RESALE

Step	Check	Yes	No
1 CHECK YAW RATE & LATERAL G SENSOR POWER SUPPLY. 1) Turn the ignition switch to OFF. 2) Disconnect the connector from yaw rate & lateral G sensor. 3) Turn the ignition switch to ON. 4) Measure the voltage between yaw rate & lateral G sensor and chassis ground. Connector & terminal (B230) No. 1 (+) — Chassis ground (-):	Is the voltage 10 — 15 V?	Go to step 2.	Repair the power supply circuit of the yaw rate & lateral G sensor.
2 CHECK YAW RATE & LATERAL G SENSOR GROUND CIRCUIT. Measure the resistance between the yaw rate & lateral G sensor and chassis ground. Connector & terminal (B230) No. 4 — Chassis ground:	Is the resistance less than 0.5 Ω?	Go to step 3.	Repair the ground circuit of the yaw rate & lateral G sensor.
3 CHECK YAW RATE & LATERAL G SENSOR. 1) Turn the ignition switch to OFF. 2) Connect all connectors. 3) Erase the memory. 4) Perform the Inspection Mode. 5) Read the DTC.	Is the same DTC displayed?	Replace the yaw rate & lateral G sensor.	Go to step 4.
4 CHECK OTHER DTC DETECTION.	Is any other DTC displayed?	Perform the diagnosis according to DTC.	Temporary poor contact occurs.

Diagnostic Procedure with Diagnostic Trouble Code (DTC)

VEHICLE DYNAMICS CONTROL (VDC) (DIAGNOSTICS)

Brought to you by Eris Studios
NOT FOR SALE

AT:DTC C0072 CHANGE RANGE OF YAW RATE SENSOR SIGNAL IS TOO BIG

DTC DETECTING CONDITION:

Defective yaw rate sensor

TROUBLE SYMPTOM:

VDC does not operate.

WIRING DIAGRAM:

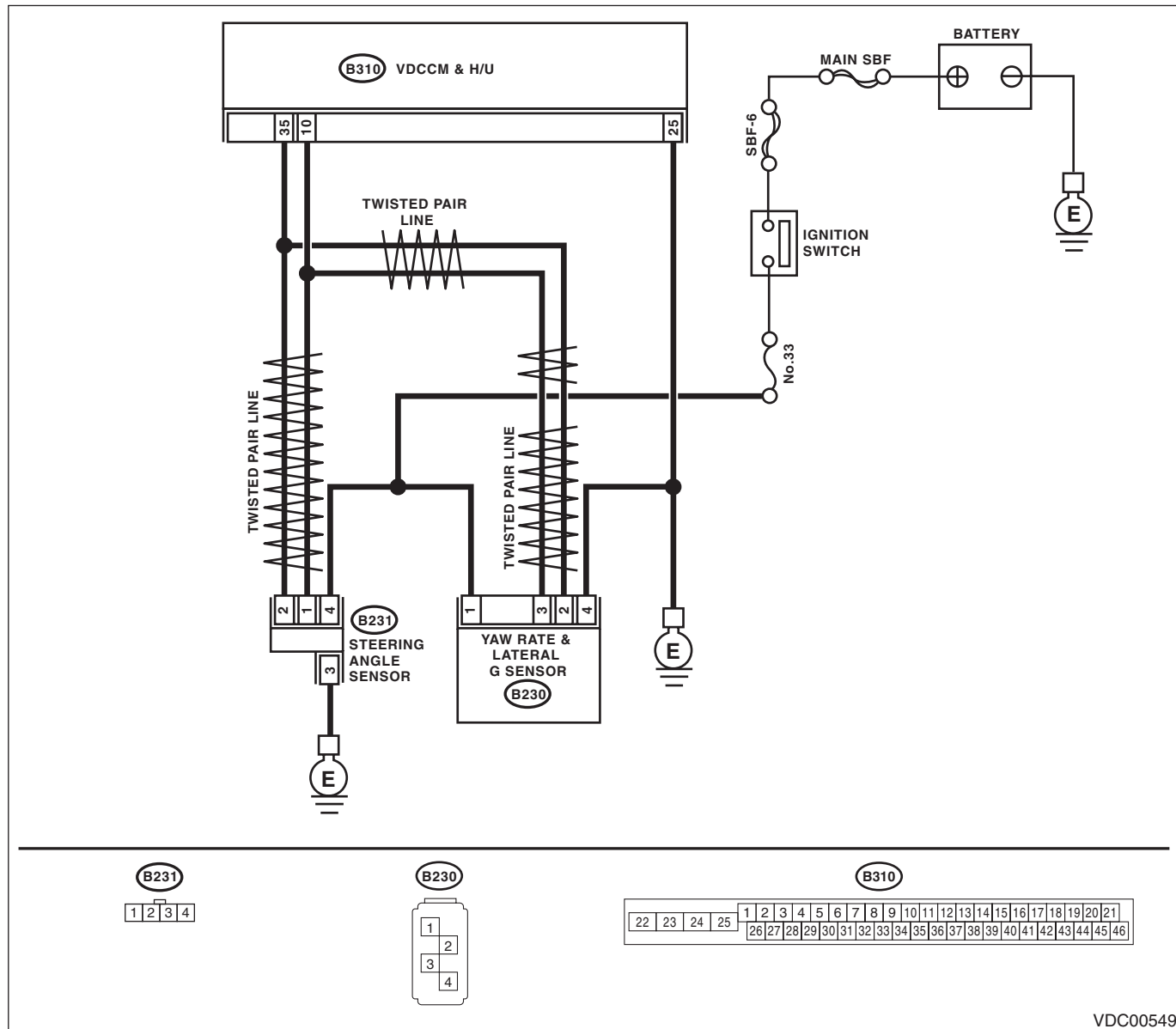

VDC00549

Diagnostic Procedure with Diagnostic Trouble Code (DTC)

VEHICLE DYNAMICS CONTROL (VDC) (DIAGNOSTICS)

Brought to you by Eris Studios
NOT FOR RESALE

	Step	Check	Yes	No
1	CHECK DRIVING PLACE. Check if the vehicle ran the road with banks or sandy surface (which does not mean a dirt road).	Did the vehicle run the road with banks or sandy surface (which does not mean a dirt road) ?	VDCCM&H/U may record DTC when the vehicle ran the road with banks or sandy surface (which does not mean a dirt road).	Go to step 2.
2	CHECK YAW RATE & LATERAL G SENSOR INSTALLATION.	Is the yaw rate & lateral G sensor installation bolt tightened to 7.5 N·m (0.76 kgf·m, 5.5 ft·lb)?	Go to step 3.	Tighten the yaw rate & lateral G sensor installation bolt.
3	CHECK YAW RATE & LATERAL G SENSOR POWER SUPPLY. 1) Turn the ignition switch to OFF. 2) Disconnect the connector from yaw rate & lateral G sensor. 3) Turn the ignition switch to ON. 4) Measure the voltage between yaw rate & lateral G sensor and chassis ground. Connector & terminal (B230) No. 1 (+) — Chassis ground (-):	Is the voltage 10 — 15 V?	Go to step 4.	Repair the power supply circuit of the yaw rate & lateral G sensor.
4	CHECK YAW RATE & LATERAL G SENSOR GROUND CIRCUIT. Measure the resistance between the yaw rate & lateral G sensor and chassis ground. Connector & terminal (B230) No. 4 — Chassis ground:	Is the resistance less than 0.5 Ω?	Go to step 5.	Repair the ground circuit of the yaw rate & lateral G sensor.
5	CHECK OUTPUT OF YAW RATE & LATERAL G SENSOR WITH SUBARU SELECT MONITOR. 1) Drive the vehicle on a flat road. 2) Park the vehicle straight. 3) Select {Current Data Display & Save} in Subaru Select Monitor. 4) Read the yaw rate output displayed on display.	Is the reading indicated on monitor display -4 — 4 deg/s?	Go to step 6.	Replace the yaw rate & lateral G sensor.
6	CHECK YAW RATE & LATERAL G SENSOR. 1) Turn the ignition switch to OFF. 2) Connect all connectors. 3) Erase the memory. 4) Perform the Inspection Mode. 5) Read the DTC.	Is the same DTC displayed?	Go to step 7.	Go to step 8.
7	CHECK THE VDCCM&H/U. 1) Turn the ignition switch to OFF. 2) Replace the yaw rate & lateral G sensor. 3) Erase the memory. 4) Perform the Inspection Mode. 5) Read the DTC.	Is the same DTC displayed?	Replace the VDCCM only. <Ref. to VDC-10, REPLACEMENT, VDC Control Module and Hydraulic Control Unit (VDCCM&H/U).>	Go to step 9.
8	CHECK OTHER DTC DETECTION.	Is any other DTC displayed?	Perform the diagnosis according to DTC.	Temporary poor contact occurs.
9	CHECK OTHER DTC DETECTION.	Is any other DTC displayed?	Perform the diagnosis according to DTC.	Malfunction is found in original yaw rate & lateral G sensor.

Diagnostic Procedure with Diagnostic Trouble Code (DTC)

VEHICLE DYNAMICS CONTROL (VDC) (DIAGNOSTICS)

Brought to you by Eris Studios
NOT FOR SALE

AU:DTC C0072 YAW RATE SENSOR COMMUNICATION

DTC DETECTING CONDITION:

Communication failure between yaw rate sensor and VDCCM

TROUBLE SYMPTOM:

- ABS does not operate.
- VDC does not operate.

WIRING DIAGRAM:

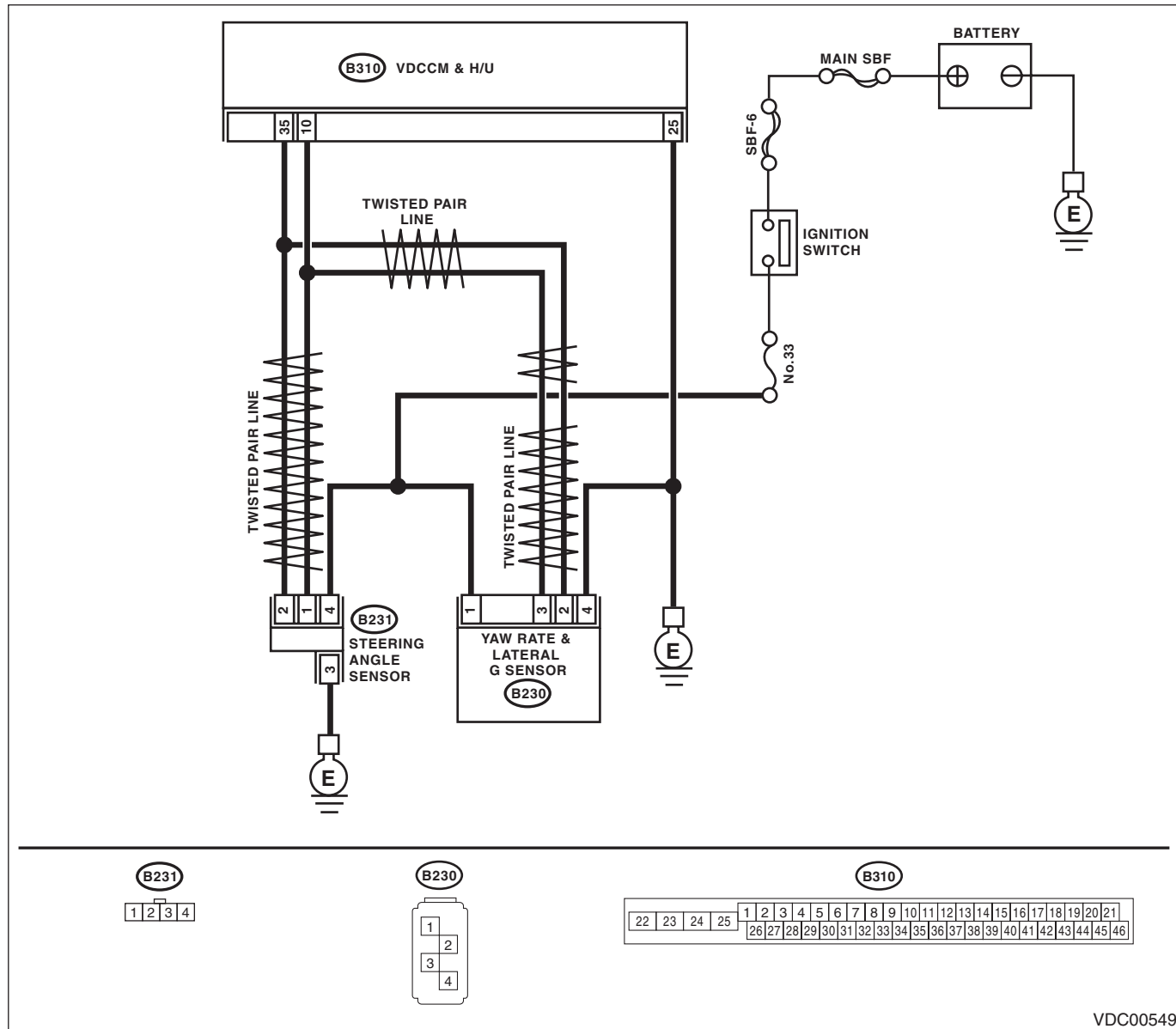

VDC00549

Diagnostic Procedure with Diagnostic Trouble Code (DTC)

VEHICLE DYNAMICS CONTROL (VDC) (DIAGNOSTICS)

Brought to you by Eris Studios
NOT FOR RESALE

Step	Check	Yes	No
1 CHECK POWER SUPPLY FOR YAW RATE & LATERAL G SENSOR. 1) Turn the ignition switch to OFF. 2) Disconnect the connector from yaw rate & lateral G sensor. 3) Turn the ignition switch to ON. 4) Measure the voltage between yaw rate & lateral G sensor and chassis ground. Connector & terminal (B230) No. 1 (+) — Chassis ground (-):	Is the voltage 10 — 15 V?	Go to step 2.	Repair the power supply circuit of the yaw rate & lateral G sensor.
2 CHECK YAW RATE & LATERAL G SENSOR GROUND CIRCUIT. Measure the resistance between the yaw rate & lateral G sensor and chassis ground. Connector & terminal (B230) No. 4 — Chassis ground:	Is the resistance less than 0.5 Ω?	Go to step 3.	Repair the ground circuit of the yaw rate & lateral G sensor.
3 CHECK YAW RATE & LATERAL G SENSOR HARNESS. 1) Disconnect the connector from the VDCCM&H/U. 2) Measure the resistance between VDCCM&H/U and yaw rate & lateral G sensor. Connector & terminal (B230) No. 3 — (B310) No. 10: (B230) No. 2 — (B310) No. 35:	Is the resistance less than 0.5 Ω?	Go to step 4.	Repair the harness between yaw rate & lateral G sensor and VDCCM & H/U.
4 CHECK GROUND SHORT CIRCUIT FOR YAW RATE & LATERAL G SENSOR HARNESS. Measure the resistance between the yaw rate & lateral G sensor and chassis ground. Connector & terminal (B230) No. 2 — Chassis ground: (B230) No. 3 — Chassis ground:	Is the resistance 1 MΩ or more?	Go to step 5.	Repair the harness between yaw rate & lateral G sensor and VDCCM & H/U.
5 CHECK YAW RATE & LATERAL G SENSOR. 1) Turn the ignition switch to OFF. 2) Connect all connectors. 3) Erase the memory. 4) Perform the Inspection Mode. 5) Read the DTC.	Is the same DTC displayed?	Go to step 6.	Go to step 7.
6 CHECK YAW RATE & LATERAL G SENSOR. 1) Turn the ignition switch to OFF. 2) Replace the yaw rate & lateral G sensor. 3) Erase the memory. 4) Perform the Inspection Mode. 5) Read the DTC.	Is the same DTC displayed?	Replace the VDCCM only. <Ref. to VDC-10, REPLACEMENT, VDC Control Module and Hydraulic Control Unit (VDCCM&H/U).>	Go to step 8.
7 CHECK OTHER DTC DETECTION.	Is any other DTC displayed?	Perform the diagnosis according to DTC.	Temporary poor contact occurs.
8 CHECK OTHER DTC DETECTION.	Is any other DTC displayed?	Perform the diagnosis according to DTC.	Malfunction is found in original yaw rate & lateral G sensor.

Diagnostic Procedure with Diagnostic Trouble Code (DTC)

VEHICLE DYNAMICS CONTROL (VDC) (DIAGNOSTICS)

Brought to you by Eris Studios
NOT FOR SALE

AV:DTC C0072 SENSOR TYPE ABNORMAL

DTC DETECTING CONDITION:

Different yaw rate sensor specification

Trouble symptom:

- VDC does not operate.
- Hill start assist does not operate.

Step	Check	Yes	No
1 CHECK YAW RATE & LATERAL G SENSOR IDENTIFICATION NUMBER. Check the identification number on the sticker applied on the top of the yaw rate & lateral G sensor.	Is the identification number correct? MT:R AT:S	Go to step 2.	Replace the yaw rate & lateral G sensor with the proper product.
2 CHECK VDCCM&H/U IDENTIFICATION NUMBER. Check the identification number on the sticker printed on the upper side of the H/U.	Is the identification number correct? MT:S2 AT:S1	Replace the VDCCM only. <Ref. to VDC-10, REPLACEMENT, VDC Control Module and Hydraulic Control Unit (VDCCM&H/U).>	Replace the VDCCM&H/U. <Ref. to VDC-7, VDC Control Module and Hydraulic Control Unit (VDCCM&H/U).>

AW:DTC C0073 LATERAL G SENSOR OFFSET IS TOO BIG

NOTE:

For the diagnostic procedure, refer to DTC C0073 "EXCESSIVE LATERAL G SENSOR SIGNAL". <Ref. to VDC(diag)-94, DTC C0073 EXCESSIVE LATERAL G SENSOR SIGNAL, Diagnostic Procedure with Diagnostic Trouble Code (DTC).>

AX:DTC C0073 ABNORMAL LATERAL G SENSOR OUTPUT

NOTE:

For the diagnostic procedure, refer to DTC C0073 "EXCESSIVE LATERAL G SENSOR SIGNAL". <Ref. to VDC(diag)-94, DTC C0073 EXCESSIVE LATERAL G SENSOR SIGNAL, Diagnostic Procedure with Diagnostic Trouble Code (DTC).>

Diagnostic Procedure with Diagnostic Trouble Code (DTC)

VEHICLE DYNAMICS CONTROL (VDC) (DIAGNOSTICS)

Brought to you by Eris Studios
NOT FOR RESALE

AY:DTC C0073 EXCESSIVE LATERAL G SENSOR SIGNAL

DTC DETECTING CONDITION:

Lateral G sensor malfunction

TROUBLE SYMPTOM:

VDC does not operate.

WIRING DIAGRAM:

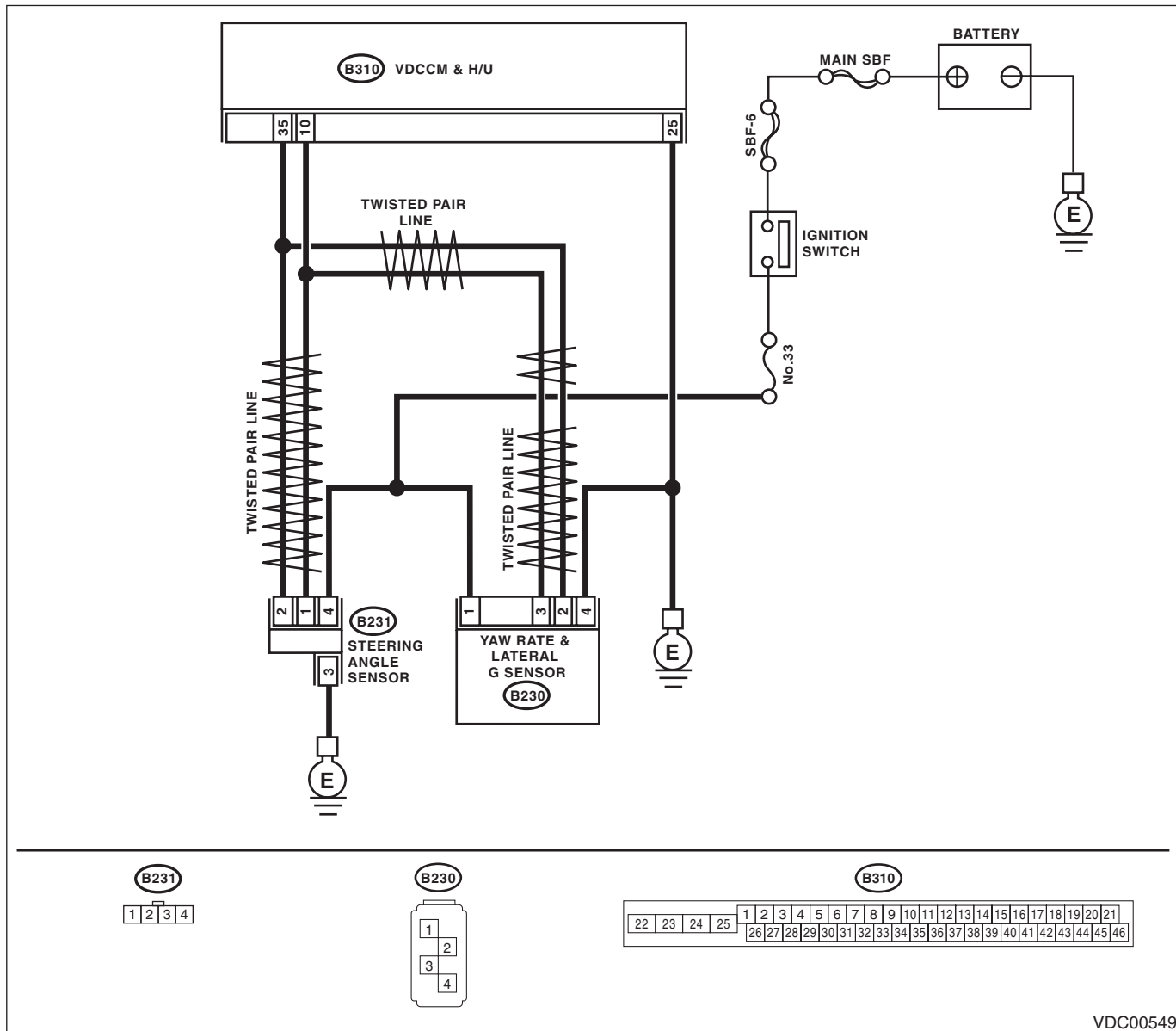

VDC00549

Diagnostic Procedure with Diagnostic Trouble Code (DTC)

VEHICLE DYNAMICS CONTROL (VDC) (DIAGNOSTICS)

Brought to you by Eriss Studios
NOT FOR SALE

Step	Check	Yes	No
1 CHECK YAW RATE & LATERAL G SENSOR INSTALLATION.	Is the yaw rate & lateral G sensor installation bolt tightened to 7.5 N·m (0.76 kgf·m, 5.5 ft·lb)?	Go to step 2.	Tighten the yaw rate & lateral G sensor installation bolt.
2 CHECK LATERAL G SENSOR OUTPUT. 1) Park the vehicle on a level surface. 2) Select {Current Data Display & Save} in Subaru Select Monitor. 3) Read the lateral G sensor output displayed on screen.	Is the indicated reading on the monitor display -1.5 — 1.5 m/s ² ?	Go to step 3.	Replace the yaw rate & lateral G sensor.
3 CHECK LATERAL G SENSOR OUTPUT. 1) Turn the ignition switch to OFF. 2) Remove the yaw rate & lateral G sensors from vehicle. 3) Turn the ignition switch to ON, and select {Current Data Display & Save} in Subaru Select Monitor. 4) Read the lateral G sensor output displayed on screen.	When the yaw rate & lateral G sensor is inclined 90° to the right, is the indicated value 6.8 — 12.8 m/s ² ?	Go to step 4.	Replace the yaw rate & lateral G sensor.
4 CHECK LATERAL G SENSOR. Read the lateral G sensor output displayed on screen.	When the yaw rate & lateral G sensor is inclined 90° to the left, is the indicated value -6.8 — -12.8 m/s ² ?	Go to step 5.	Replace the yaw rate & lateral G sensor.
5 CHECK POOR CONTACT IN CONNECTORS. Turn the ignition switch to OFF.	Is there poor contact in connector between VDCCM& H/U and yaw rate & lateral G sensor?	Repair the connector.	Go to step 6.
6 CHECK THE VDCCM&H/U. 1) Connect all connectors. 2) Erase the memory. 3) Perform the Inspection Mode. 4) Read the DTC.	Is the same DTC displayed?	Replace the VDCCM only. <Ref. to VDC-10, REPLACEMENT, VDC Control Module and Hydraulic Control Unit (VDCCM&H/U).>	Go to step 7.
7 CHECK OTHER DTC DETECTION.	Is any other DTC displayed?	Perform the diagnosis according to DTC.	Temporary poor contact occurs.

Diagnostic Procedure with Diagnostic Trouble Code (DTC)

VEHICLE DYNAMICS CONTROL (VDC) (DIAGNOSTICS)

Brought to you by Eris Studios
NOT FOR RESALE

AZ:DTC C0074 PRESSURE SENSOR

DTC DETECTING CONDITION:

Defective pressure sensor

TROUBLE SYMPTOM:

- ABS does not operate.
- VDC does not operate.

Step	Check	Yes	No	
1	CHECK STOP LIGHT SWITCH CIRCUIT. Check stop light switch open circuit.	Is the stop light switch circuit OK?	Go to step 2.	Repair the stop light switch circuit. NOTE: If there is malfunction in the stop light circuit, DTC may be memorized.
2	CHECK OUTPUT OF PRESSURE SENSOR WITH SUBARU SELECT MONITOR. 1) Select {Current Data Display & Save} in Subaru Select Monitor. 2) Read the pressure sensor output displayed on display.	When the brake pedal is released, is the displayed value -40 — 40 bar?	Go to step 3.	Replace the VDCCM&H/U. <Ref. to VDC-7, VDC Control Module and Hydraulic Control Unit (VDCCM&H/U).>
3	CHECK OUTPUT OF PRESSURE SENSOR WITH SUBARU SELECT MONITOR. 1) Select {Current Data Display & Save} in Subaru Select Monitor. 2) Read the pressure sensor output displayed on display.	When operating the brake pedal, does the pressure sensor output value on the display change according to the brake pedal operation?	Go to step 4.	Replace the VDCCM&H/U. <Ref. to VDC-7, VDC Control Module and Hydraulic Control Unit (VDCCM&H/U).>
4	CHECK PRESSURE SENSOR. 1) Erase the memory. 2) Perform the Inspection Mode. 3) Read the DTC.	Is the same DTC displayed?	Replace the VDCCM&H/U. <Ref. to VDC-7, VDC Control Module and Hydraulic Control Unit (VDCCM&H/U).>	Go to step 5.
5	CHECK OTHER DTC DETECTION.	Is any other DTC displayed?	Perform the diagnosis according to DTC. <Ref. to VDC(diag)-32, List of Diagnostic Trouble Code (DTC).>	It results from a temporary noise interference.

Diagnostic Procedure with Diagnostic Trouble Code (DTC)

VEHICLE DYNAMICS CONTROL (VDC) (DIAGNOSTICS)

Brought to you by Eris Studios
NOT FOR SALE

BA:DTC C0075 REVERSE SIGNAL

DTC DETECTING CONDITION:

Reverse signal malfunction

Trouble symptom:

Hill start assist does not operate.

WIRING DIAGRAM:

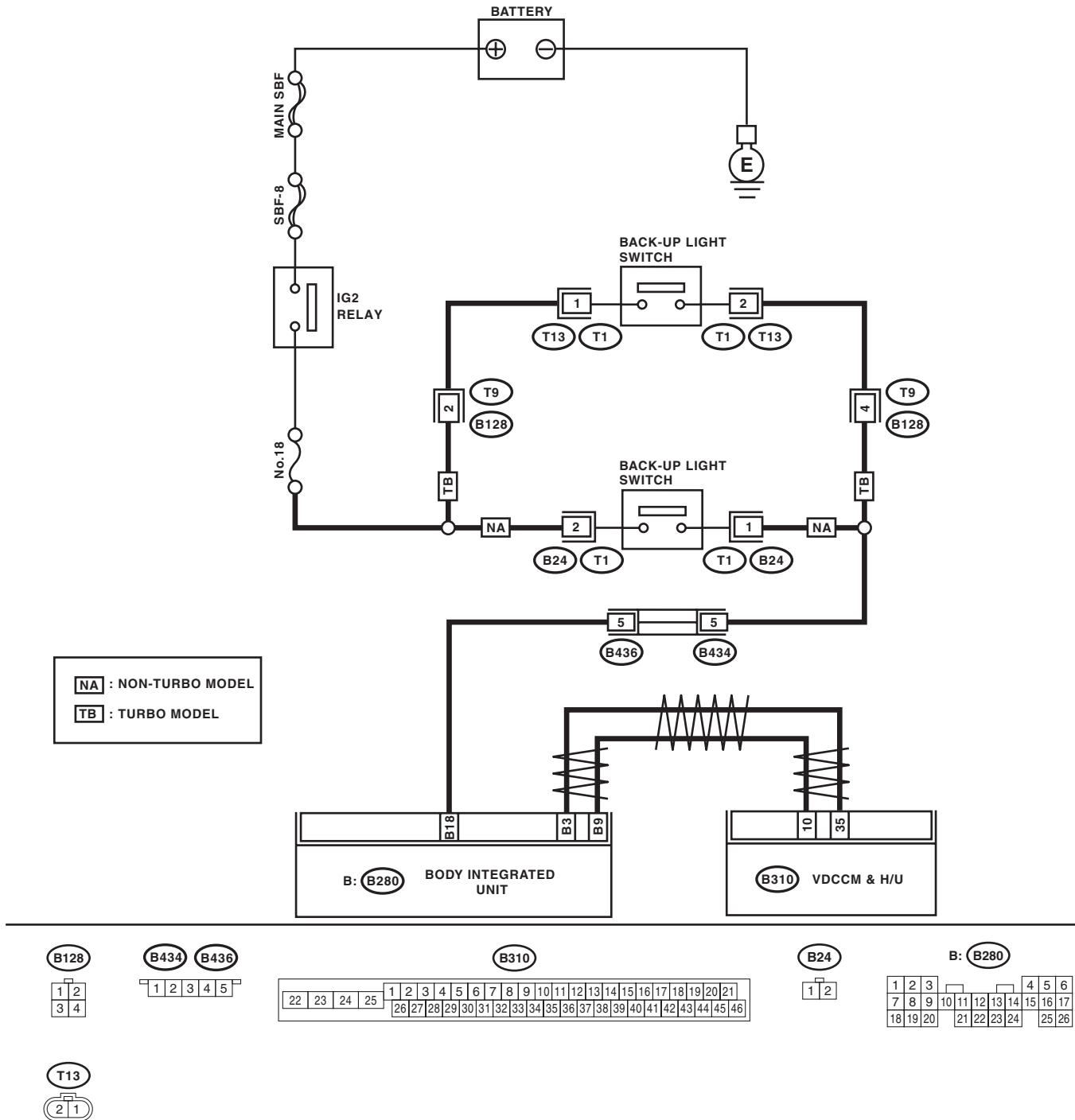

VDC00560

Diagnostic Procedure with Diagnostic Trouble Code (DTC)

VEHICLE DYNAMICS CONTROL (VDC) (DIAGNOSTICS)

Brought to you by Eris Studios
NOT FOR RESALE

Step	Check	Yes	No
1 CHECK LAN SYSTEM. Perform the diagnosis for LAN system. <Ref. to LAN(diag)-29, OPERATION, Read Diagnostic Trouble Code (DTC).>	Is there any fault in LAN system?	Perform the diagnosis according to DTC for LAN system.	Go to step 2.
2 CHECK REVERSE SIGNAL USING SUBARU SELECT MONITOR. 1) Select {Current Data Display & Save} in the Subaru Select Monitor. 2) Read the display of the reverse signal.	Is OFF displayed when the shift position is in a position other than reverse, and ON when it is placed in reverse?	Go to step 5.	Go to step 3.
3 CHECK LIGHTING OF BACK-UP LIGHT. 1) Turn the ignition switch to ON. 2) Set the shift lever to the reverse position.	Does the back-up light illuminate?	Go to step 4.	Repair the back-up light circuit.
4 CHECK HARNESS BETWEEN BODY INTEGRATED UNIT AND BACK-UP LIGHT SWITCH. 1) Turn the ignition switch to OFF. 2) Disconnect the connector from the body integrated unit and the back-up light switch. 3) Measure the resistance of the harness between the body integrated unit and back-up light switch connector. Connector & terminal Non-turbo model (B280) No. 18 — (B24) No. 1: Turbo model (B280) No. 18 — (T13) No. 2:	Is resistance less than 0.5 Ω?	Replace the back-up light switch. <Ref. to 5MT-35, Switches and Harness.>	Repair the harness between the body integrated unit and back-up light switch connector.
5 CHECK THE VDCCM&H/U. 1) Connect all connectors. 2) Erase the memory. 3) Perform the Inspection Mode. 4) Read the DTC.	Is the same DTC displayed?	Replace the VDCCM only. <Ref. to VDC-10, REPLACEMENT, VDC Control Module and Hydraulic Control Unit (VDCCM&H/U).>	Go to step 6.
6 CHECK OTHER DTC DETECTION.	Is any other DTC displayed?	Perform the diagnosis according to DTC.	Temporary poor contact occurs.

Diagnostic Procedure with Diagnostic Trouble Code (DTC)

VEHICLE DYNAMICS CONTROL (VDC) (DIAGNOSTICS)

Brought to you by Eris Studios
NOT FOR SALE

BB:DTC C0076 CLUTCH SIGNAL

DTC DETECTING CONDITION:

Clutch signal malfunction

Trouble symptom:

Hill start assist does not operate.

WIRING DIAGRAM:

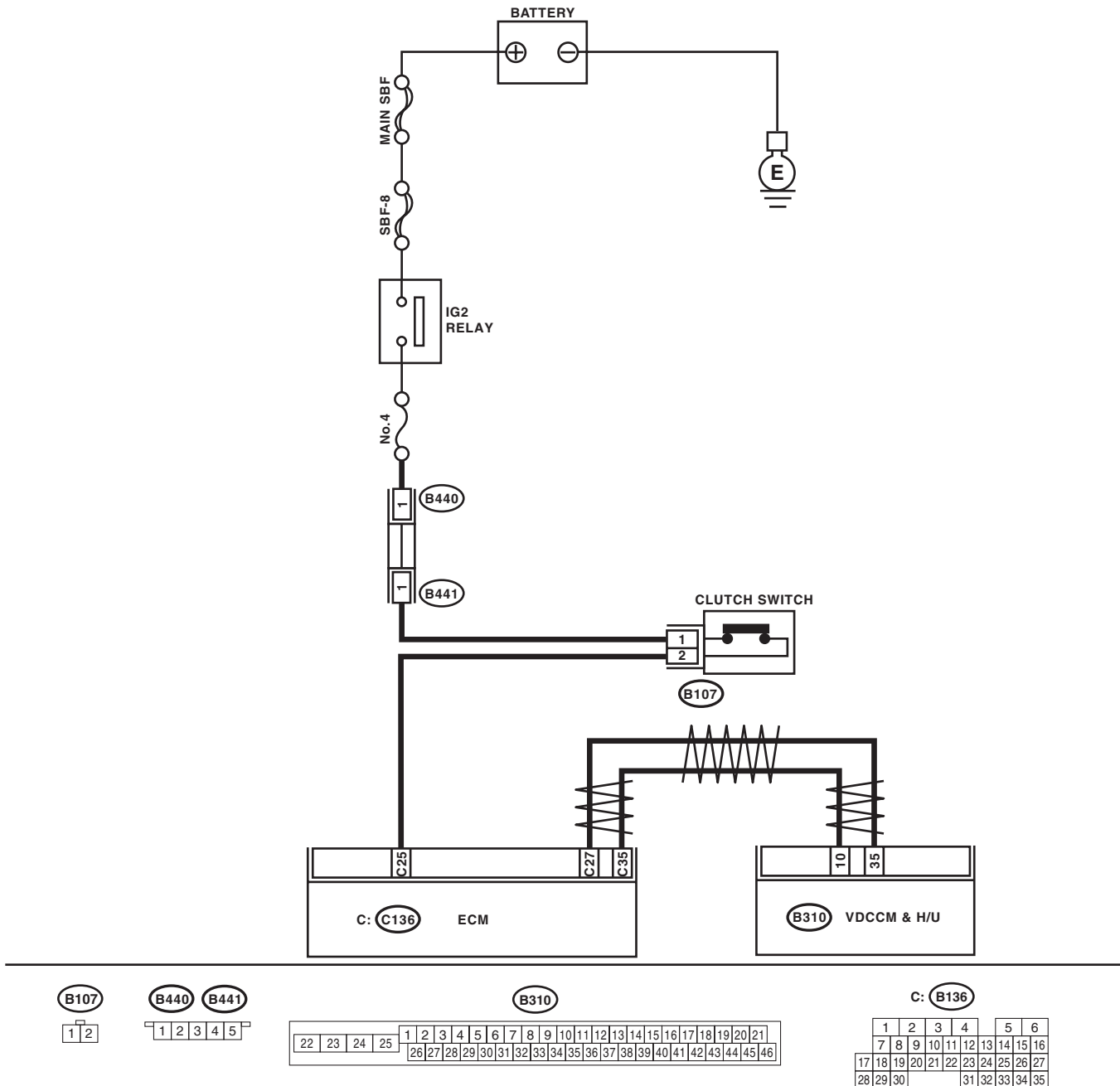

VDC00561

Diagnostic Procedure with Diagnostic Trouble Code (DTC)

VEHICLE DYNAMICS CONTROL (VDC) (DIAGNOSTICS)

Brought to you by Eris Studios
NOT FOR RESALE

Step	Check	Yes	No
1 CHECK LAN SYSTEM. Perform the diagnosis for LAN system. <Ref. to LAN(diag)-29, OPERATION, Read Diagnostic Trouble Code (DTC).>	Is there any fault in LAN system?	Perform the diagnosis according to DTC for LAN system.	Go to step 2.
2 CHECK CLUTCH SIGNAL USING SUBARU SELECT MONITOR. 1) Select {Current Data Display & Save} in Subaru Select Monitor. 2) Read the display of the clutch switch signal.	Is OFF displayed while the clutch pedal is released, is ON displayed when it is depressed?	Go to step 5.	Go to step 3.
3 CHECK ECM CLUTCH SIGNAL USING SUBARU SELECT MONITOR. 1) Select {Current Data Display & Save} of the ECM in the Subaru Select Monitor. 2) Read the display of the clutch switch signal.	Is OFF displayed while the clutch pedal is released, is ON displayed when it is depressed?	Go to step 5.	Go to step 4.
4 CHECK HARNESS BETWEEN ECM AND CLUTCH SWITCH. 1) Turn the ignition switch to OFF. 2) Disconnect the connector from the ECM and the clutch switch. 3) Measure the resistance of harness between the ECM and clutch switch connector. Connector & terminal (B136) No. 25 — (B107) No. 2:	Is resistance less than 0.5 Ω?	Repair the clutch switch power supply circuit. Or, replace the clutch switch. <Ref. to CL-26, Clutch Switch.>	Repair the harness between the ECM and clutch switch connector.
5 CHECK THE VDCCM&H/U. 1) Connect all connectors. 2) Erase the memory. 3) Perform the Inspection Mode. 4) Read the DTC.	Is the same DTC displayed?	Replace the VDCCM only. <Ref. to VDC-10, REPLACEMENT, VDC Control Module and Hydraulic Control Unit (VDCCM&H/U).>	Go to step 6.
6 CHECK OTHER DTC DETECTION.	Is any other DTC displayed?	Perform the diagnosis according to DTC.	Temporary poor contact occurs.

BC:DTC C0081 SYSTEM FAILURE

DTC DETECTING CONDITION:

VDC long time sequential control

TROUBLE SYMPTOM:

- ABS does not operate.
- VDC does not operate.

Step	Check	Yes	No
1 CHECK POOR CONTACT IN CONNECTOR.	Is there poor contact in the VDCCM& H/U and yaw rate & lateral G sensor connector?	Repair the connector.	Go to step 2.
2 CHECK THE VDCCM&H/U. 1) Replace the yaw rate & lateral G sensor. 2) Connect all connectors. 3) Erase the memory. 4) Perform the Inspection Mode. 5) Read the DTC.	Is the same DTC displayed?	Replace the VDCCM&H/U.	Malfunction is found in original yaw rate & lateral G sensor.

General Diagnostic Table

VEHICLE DYNAMICS CONTROL (VDC) (DIAGNOSTICS)

Brought to you by Eris Studios
NOT FOR SALE

13. General Diagnostic Table

A: INSPECTION

Symptom		Main probable cause	Other probable cause
Poor brake performance	Long braking/ stopping distance	<ul style="list-style-type: none"> • VDCCM&H/U • Brake pad • Aeration to brake line • Tire specifications, tire wear and air pressures • Incorrect wiring or piping connections 	<ul style="list-style-type: none"> • Defective ABS wheel speed sensor or sensor gap • Defective steering angle sensor or improper neutral position • Defective yaw rate & lateral G sensor or improper installation • Master cylinder • Brake caliper • Disc rotor • Brake pipe • Brake booster
	Wheel lock	<ul style="list-style-type: none"> • VDCCM&H/U • Defective ABS wheel speed sensor or sensor gap • Incorrect wiring or piping connections 	<ul style="list-style-type: none"> • Defective steering angle sensor or improper neutral position • Defective yaw rate & lateral G sensor or improper installation • Brake caliper • Brake pipe
	Brake drag	<ul style="list-style-type: none"> • VDCCM&H/U • Defective ABS wheel speed sensor or sensor gap • Master cylinder • Brake caliper • Parking brake • Axle and wheels • Brake pedal play 	<ul style="list-style-type: none"> • Defective steering angle sensor or improper neutral position • Defective yaw rate & lateral G sensor or improper installation • Brake pad • Brake pipe
	Long brake pedal stroke	<ul style="list-style-type: none"> • Aeration to brake line • Brake pedal play 	<ul style="list-style-type: none"> • VDCCM&H/U • Master cylinder • Brake caliper • Brake pad • Brake pipe • Brake booster
	Vehicle vertical pitching	<ul style="list-style-type: none"> • VDCCM&H/U • Road surface (uneven) • Suspension play or fatigue (reduced damping) • Incorrect wiring or piping connections 	<ul style="list-style-type: none"> • Defective ABS wheel speed sensor or sensor gap • Defective steering angle sensor or improper neutral position • Defective yaw rate & lateral G sensor or improper installation
Poor brake performance	Unstable or uneven braking	<ul style="list-style-type: none"> • VDCCM&H/U • Defective ABS wheel speed sensor or sensor gap • Brake caliper • Brake pad • Road surface (uneven) • Tire specifications, tire wear and air pressures • Incorrect wiring or piping connections 	<ul style="list-style-type: none"> • Defective ABS wheel speed sensor or sensor gap • Defective steering angle sensor or improper neutral position • Defective yaw rate & lateral G sensor or improper installation • Master cylinder • Disc rotor • Brake pipe • Axle and wheels • Road with crowns or banks • Suspension play or fatigue (poor damping)

General Diagnostic Table

VEHICLE DYNAMICS CONTROL (VDC) (DIAGNOSTICS)

Brought to you by Eris Studios
NOT FOR RESALE

Symptom		Main probable cause	Other probable cause
Vibration or noise • When braking suddenly • When accelerating suddenly • While driving on a slippery road	Excessive brake pedal vibration	<ul style="list-style-type: none"> • Road surface (uneven) • Incorrect wiring or piping connections 	<ul style="list-style-type: none"> • VDCCM&H/U • Brake booster • Suspension play or fatigue (poor damping)
	Noise from VDCH/U	<ul style="list-style-type: none"> • VDCCM&H/U (mount bushing) • Defective ABS wheel speed sensor or sensor gap • Brake pipe 	<ul style="list-style-type: none"> • VDCCM&H/U • Defective steering angle sensor or improper neutral position • Defective yaw rate & lateral G sensor or improper installation
	Noise from the front side of vehicle	<ul style="list-style-type: none"> • VDCCM&H/U (mount bushing) • Defective ABS wheel speed sensor or sensor gap • Master cylinder • Brake caliper • Brake pad • Disc rotor • Brake pipe • Brake booster • Suspension play or fatigue (poor damping) 	<ul style="list-style-type: none"> • Axle and wheels • Tire specifications, tire wear and air pressures
	Noise from the rear side of vehicle	<ul style="list-style-type: none"> • Defective ABS wheel speed sensor or sensor gap • Brake caliper • Brake pad • Disc rotor • Parking brake • Brake pipe • Suspension play or fatigue (poor damping) 	<ul style="list-style-type: none"> • Axle and wheels • Tire specifications, tire wear and air pressures
Engine does not accelerate or goes into a stall when accelerating suddenly or driving on a slippery surface.		<ul style="list-style-type: none"> • VDCCM&H/U • Defective ABS wheel speed sensor or sensor gap • Master cylinder • Brake caliper • Parking brake • Incorrect wiring or piping 	<ul style="list-style-type: none"> • Defective steering angle sensor or improper neutral position • Defective yaw rate & lateral G sensor or improper installation • Brake pad • Brake pipe

General Diagnostic Table

VEHICLE DYNAMICS CONTROL (VDC) (DIAGNOSTICS)

Brought to you by Eriss Studios
NOT FOR SALE

Symptom		Main probable cause	Other probable cause
Poor change-direction-operation stability of TCS	Deviation to right or left direction	<ul style="list-style-type: none"> • VDCCM&H/U • Defective ABS wheel speed sensor or sensor gap • Defective steering angle sensor or improper neutral position • Defective yaw rate & lateral G sensor or improper installation • Brake caliper • Brake pad • Wheel alignment • Road surface (uneven) • Road with crowns or banks • Tire specifications, tire wear and air pressures • Incorrect wiring or piping connections 	<ul style="list-style-type: none"> • Disc rotor • Brake pipe • Axle and wheels • Suspension play or fatigue (poor damping)
	Vehicle spin	<ul style="list-style-type: none"> • VDCCM&H/U • Defective ABS wheel speed sensor or sensor gap • Defective steering angle sensor or improper neutral position • Defective yaw rate & lateral G sensor or improper installation • Brake pad • Tire specifications, tire wear and air pressures • Incorrect wiring or piping connections 	<ul style="list-style-type: none"> • Brake caliper • Brake pipe
Steering wheel drag while driving		<ul style="list-style-type: none"> • VDCCM&H/U • Defective ABS wheel speed sensor or sensor gap • Defective steering angle sensor or improper neutral position • Defective yaw rate & lateral G sensor or improper installation • Incorrect wiring or piping connections • Power steering system 	<ul style="list-style-type: none"> • Brake caliper • Brake pad • Disc rotor • Wheel alignment • Road surface (uneven) • Road with crowns or banks • Suspension play or fatigue (poor damping) • Tire specifications, tire wear and air pressures
VDC operates while driving normally.		<ul style="list-style-type: none"> • VDCCM&H/U • Defective ABS wheel speed sensor or sensor gap • Defective steering angle sensor or improper neutral position • Defective yaw rate & lateral G sensor or improper installation • Wheel alignment • Road surface (uneven) • Road with crowns or banks • Suspension play or fatigue (poor damping) • Tire specifications, tire wear and air pressures • Incorrect wiring or piping connections • Power steering system 	

General Diagnostic Table

VEHICLE DYNAMICS CONTROL (VDC) (DIAGNOSTICS)

Brought to you by Eris Studios
NOT FOR RESALE

Symptom	Main probable cause	Other probable cause
VDC OFF indicator light does not come on when the VDC OFF switch is depressed. NOTE: When pressing VDC OFF switch for 10 seconds or more, VDC OFF indicator light goes off and cannot operate any more. When turning the ignition switch from OFF to ON, the previous status is restored.	<ul style="list-style-type: none">• Harness• Indicator light bulb• VDC OFF switch	