

Brought to you by Eris Studios
NOT FOR RESALE

EMISSION CONTROL

(AUX. EMISSION CONTROL DEVICES)

General Description

EMISSION CONTROL (AUX. EMISSION CONTROL DEVICES)

Brought to you by Eris Studios
NOT FOR RESALE

1. General Description

A: COMPONENT

1. SECONDARY AIR PUMP

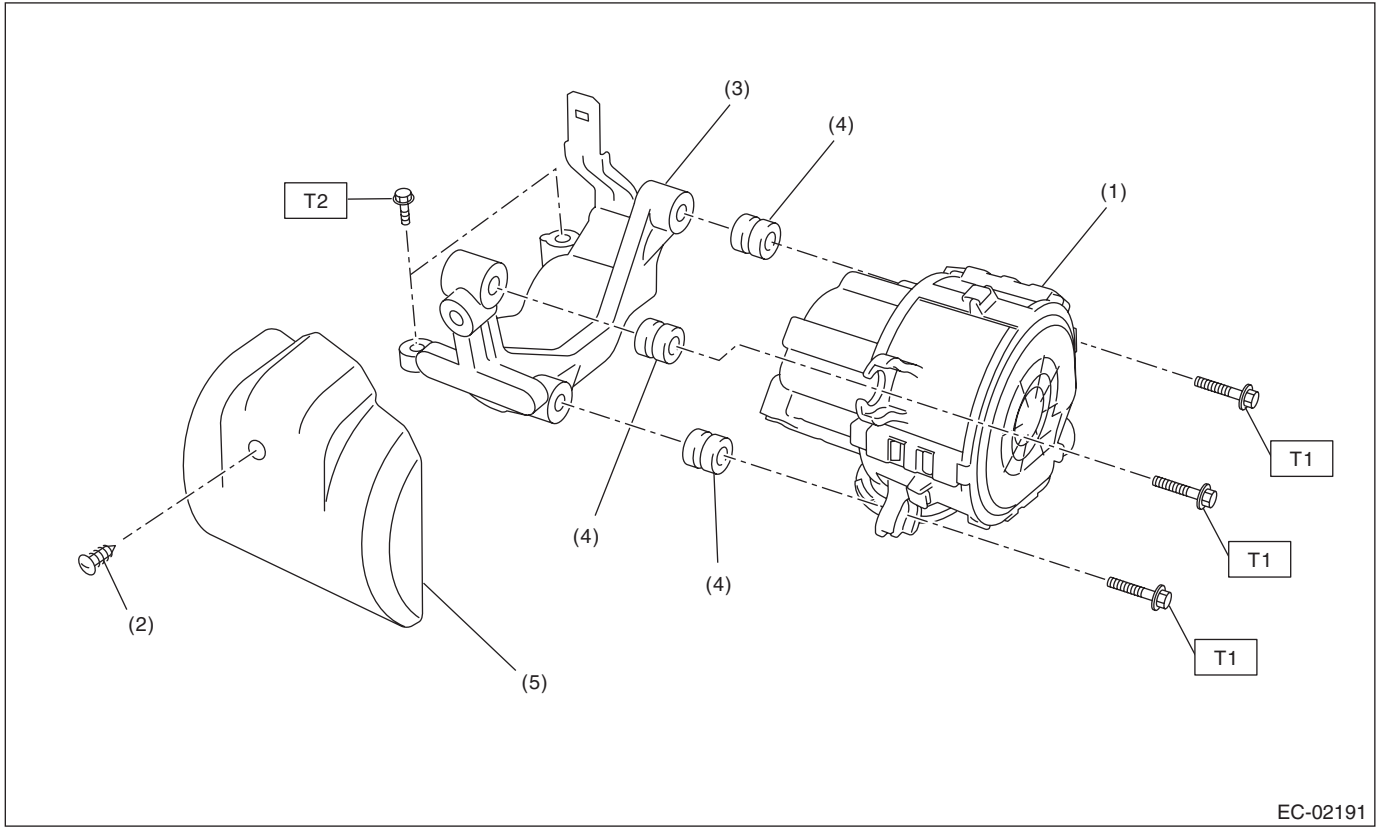

- (1) Secondary air pump
- (2) Clip
- (3) Secondary air pump bracket
- (4) Bushing
- (5) Secondary air pump cover

Tightening torque: N·m (kgf·m, ft·lb)

T1: 9 (0.9, 6.6)

T2: 19 (1.9, 14.0)

General Description

EMISSION CONTROL (AUX. EMISSION CONTROL DEVICES)

Brought to you by *Travis Studios*
NOV 2011
RESALE

2. SECONDARY AIR COMBINATION VALVE

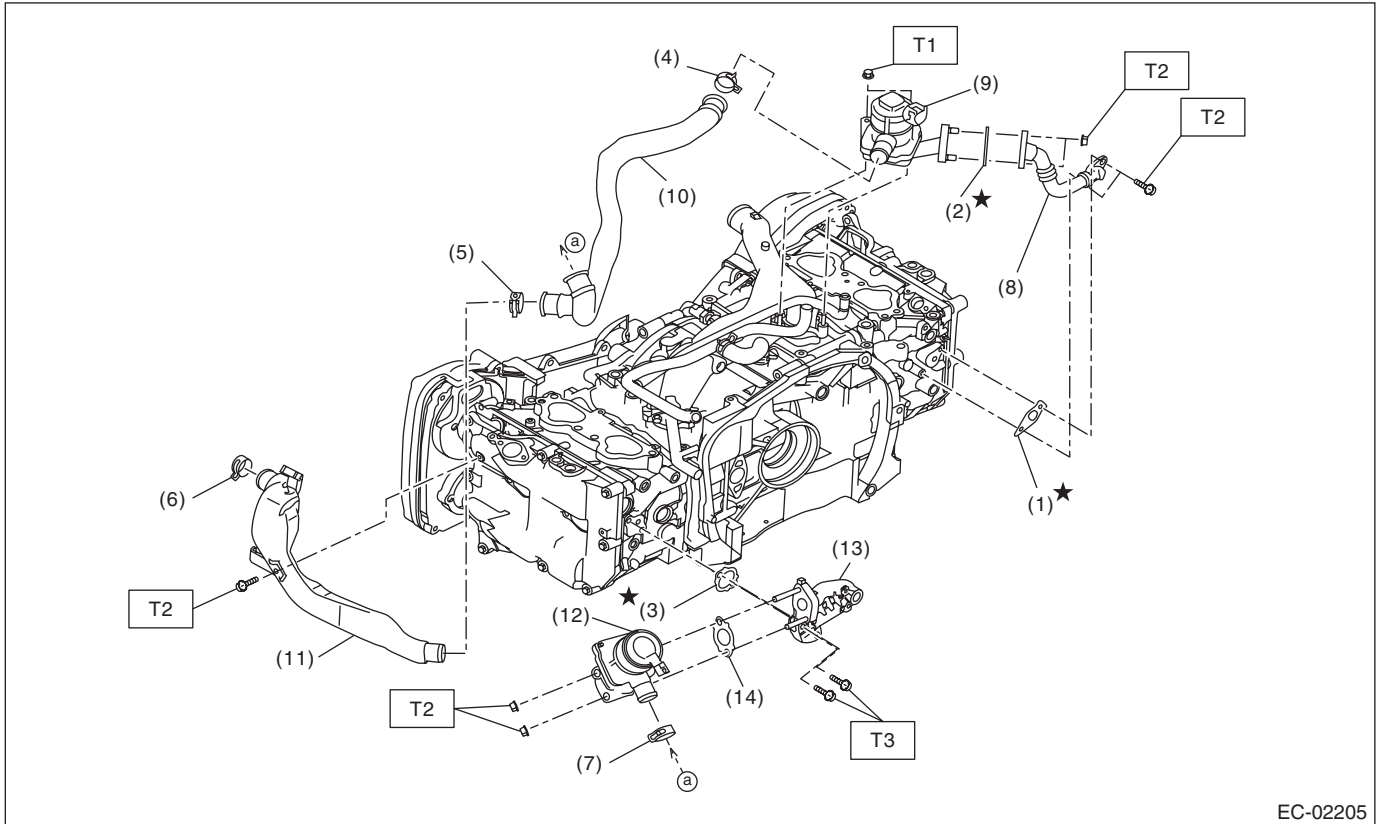

EC-02205

- | | | |
|------------|---|----------------------------|
| (1) Gasket | (8) Secondary air pipe RH | (13) Secondary air pipe LH |
| (2) Gasket | (9) Secondary air combination valve RH | (14) Gasket |
| (3) Gasket | | |
| (4) Clamp | (10) Air duct A | |
| (5) Clamp | (11) Air duct B | |
| (6) Clamp | (12) Secondary air combination valve LH | |
| (7) Clamp | | |

Tightening torque: N-m (kgf-m, ft-lb)

T1: 6.4 (0.65, 4.7)

T2: 9 (0.9, 6.6)

T3: 19 (1.9, 14.0)

B: CAUTION

- Wear appropriate work clothing, including a cap, protective goggles and protective shoes when performing any work.
- Remove contamination including dirt and corrosion before removal, installation or disassembly.
- Keep the disassembled parts in order and protect them from dust and dirt.
- Before removal, installation or disassembly, be sure to clarify the failure. Avoid unnecessary removal, installation, disassembly and replacement.
- Vehicle components are extremely hot after driving. Be wary of receiving burns from heated parts.
- Be sure to tighten fasteners including bolts and nuts to the specified torque.
- Place shop jacks or rigid racks at the specified points.
- Before disconnecting connectors of sensors or units, be sure to disconnect the ground cable from the battery.

General Description

EMISSION CONTROL (AUX. EMISSION CONTROL DEVICES)

Brought to you by Eris Studios
NOT FOR RESALE

C: PREPARATION TOOL

1. SPECIAL TOOL

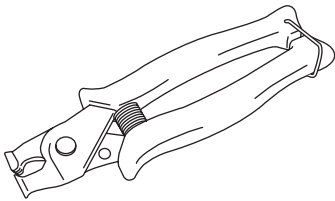
ILLUSTRATION	TOOL NUMBER	DESCRIPTION	REMARKS
 ST18353AA000	18353AA000	CLAMP PLIERS	<ul style="list-style-type: none">• Used for removing and installing the PCV hose.• This is a general tool made by the French company CAILLAU. (code) 54.0.000.205 To make this easier to obtain in the same way as genuine Subaru parts, it has been provided with a tool number as an ST.

Front Catalytic Converter

EMISSION CONTROL (AUX. EMISSION CONTROL DEVICES)

Brought to you by *Travis Studios*
NOT FOR RESALE

2. Front Catalytic Converter

A: REMOVAL

The front catalytic converter is integrated into the center exhaust pipe (front). Refer to "Center Exhaust Pipe" for removal procedures. <Ref. to EX(H4DOTC)-8, REMOVAL, Center Exhaust Pipe.>

B: INSTALLATION

The front catalytic converter is integrated into the center exhaust pipe (front). Refer to "Center Exhaust Pipe" for installation procedures. <Ref. to EX(H4DOTC)-9, INSTALLATION, Center Exhaust Pipe.>

C: INSPECTION

- 1) Check the connections and welds for exhaust leaks.
- 2) Make sure there are no holes or rusting.

Rear Catalytic Converter

EMISSION CONTROL (AUX. EMISSION CONTROL DEVICES)

Brought to you by Eris Studios
NOT FOR RESALE

3. Rear Catalytic Converter

A: REMOVAL

The rear catalytic converter is integrated into the center exhaust pipe (rear). Refer to "Center Exhaust Pipe" for removal procedures. <Ref. to EX(H4DOTC)-8, REMOVAL, Center Exhaust Pipe.>

B: INSTALLATION

The rear catalytic converter is integrated into the center exhaust pipe (rear). Refer to "Center Exhaust Pipe" for installation procedures. <Ref. to EX(H4DOTC)-9, INSTALLATION, Center Exhaust Pipe.>

C: INSPECTION

- 1) Check the connections and welds for exhaust leaks.
- 2) Make sure there are no holes or rusting.

Canister

EMISSION CONTROL (AUX. EMISSION CONTROL DEVICES)

Brought to you by *Tris Studios*
NOT FOR SALE

4. Canister

A: REMOVAL

1) Disconnect the ground cable from the battery.

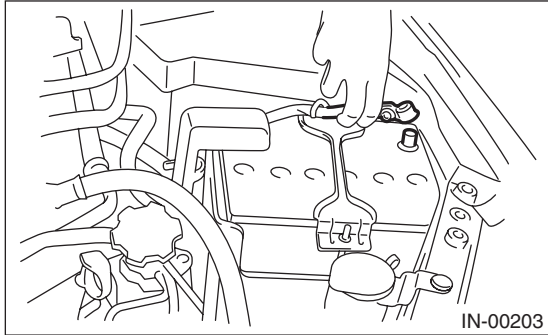

2) Open the rear gate, and remove the luggage floor mat. (Wagon model)

3) Open the trunk, and remove the trunk room mat. (Sedan model)

4) Tilt the rear seat backrest forward.

5) Slide the rear seat backrest cover RH as shown in the figure, and remove from canister cover RH.

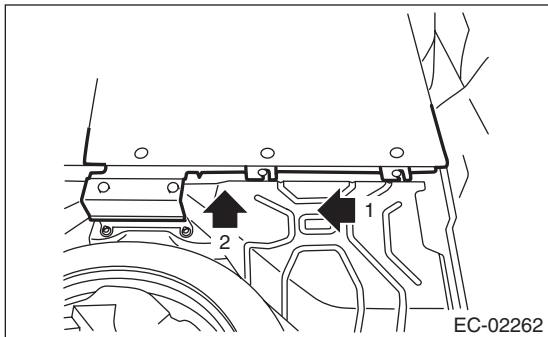

6) Remove the clips, and remove the luggage floor box RH. (Wagon model)

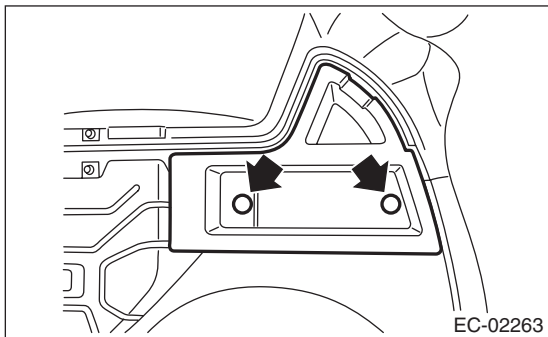

7) Remove the sub trunk. (Sedan model)

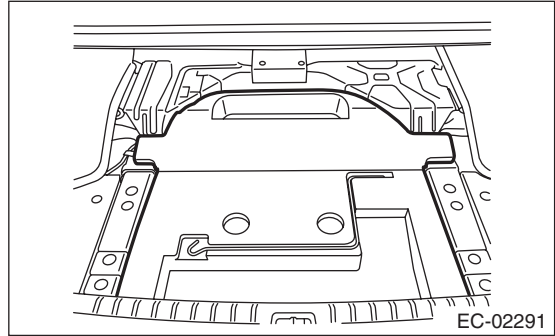

8) Remove center canister cover (A), and remove canister cover RH (B).

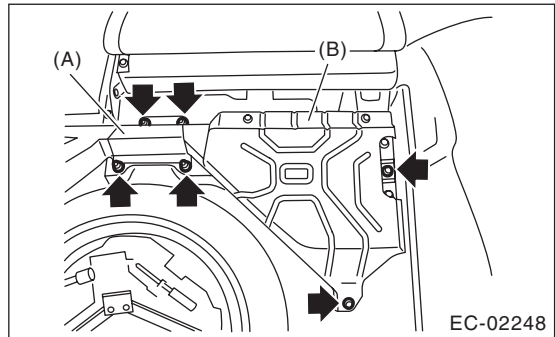

Canister

EMISSION CONTROL (AUX. EMISSION CONTROL DEVICES)

Brought to you by Eris Studios
NOT FOR RESALE

9) Disconnect the purge tube (A), vent tube (B), drain tube A (C) and PCV drain tube (D).

NOTE:

Disconnect the quick connector as shown in the figure.

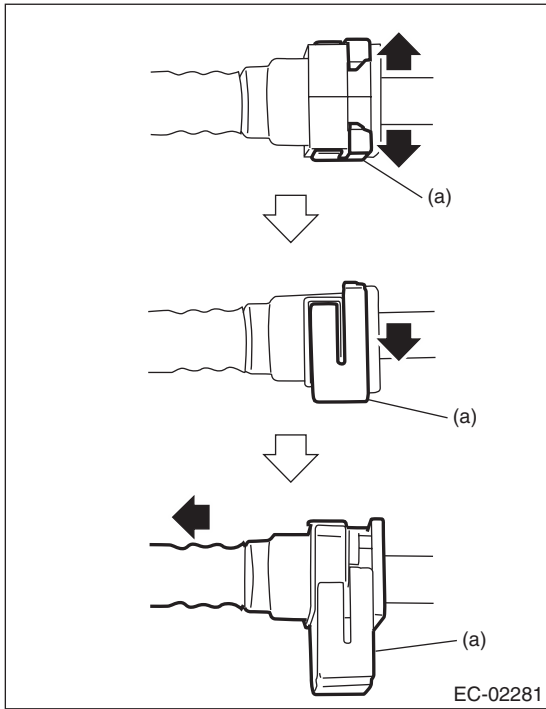

(a) Retainer

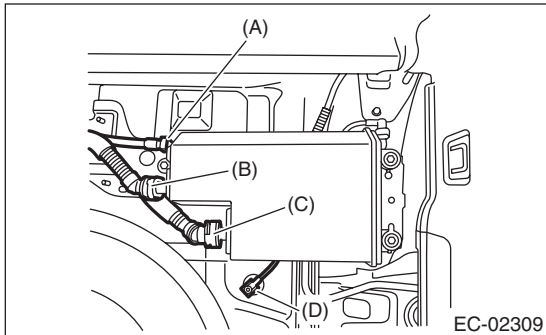

10) Remove the canister.

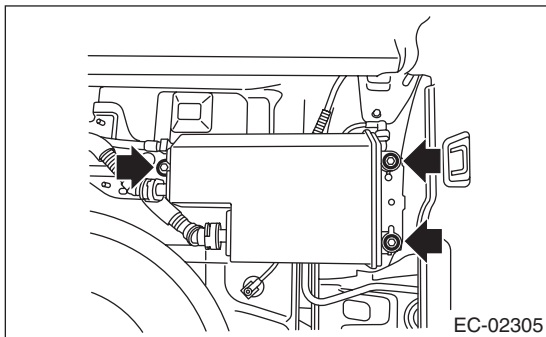

11) Remove the clip that is holding the rear seat backrest cover LH on the canister cover.

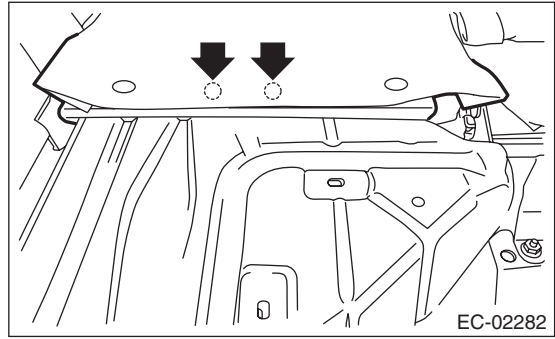

12) Remove the clip, and remove the luggage floor box LH. (Wagon model)

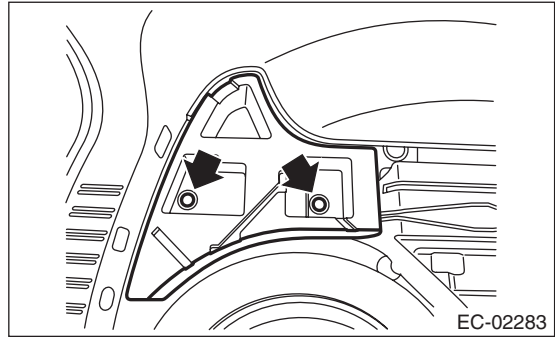

13) Remove the canister cover LH.

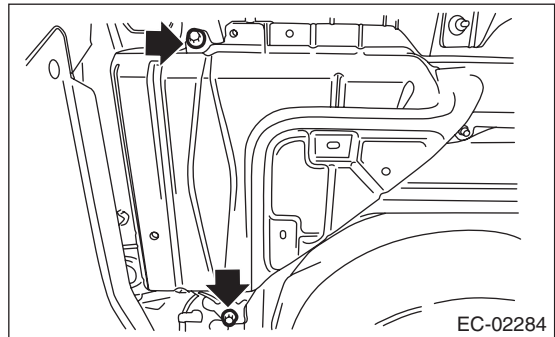

Canister

EMISSION CONTROL (AUX. EMISSION CONTROL DEVICES)

Brought to you by *Esports Studios*
NOV 2015
RESALE

14) Disconnect drain tube A (A) and drain tube B (B).

NOTE:

Disconnect the quick connector as shown in the figure.

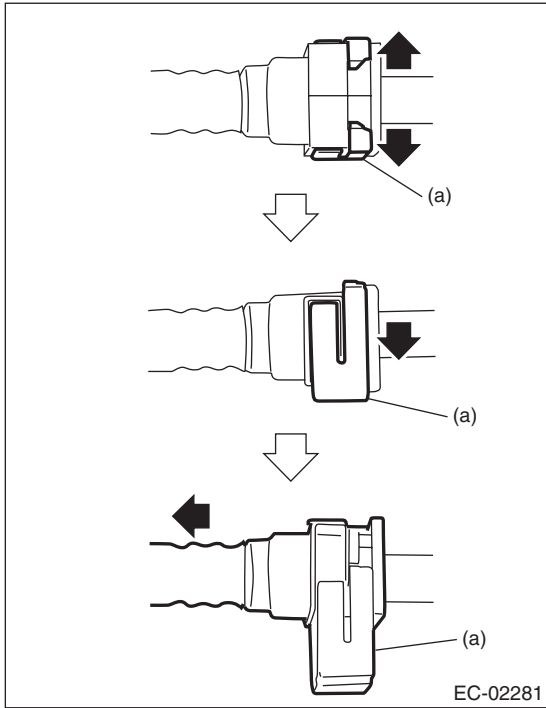

(a) Retainer

16) Disconnect purge tube (A) and vent tube (B).

NOTE:

Disconnect the quick connector as shown in the figure.

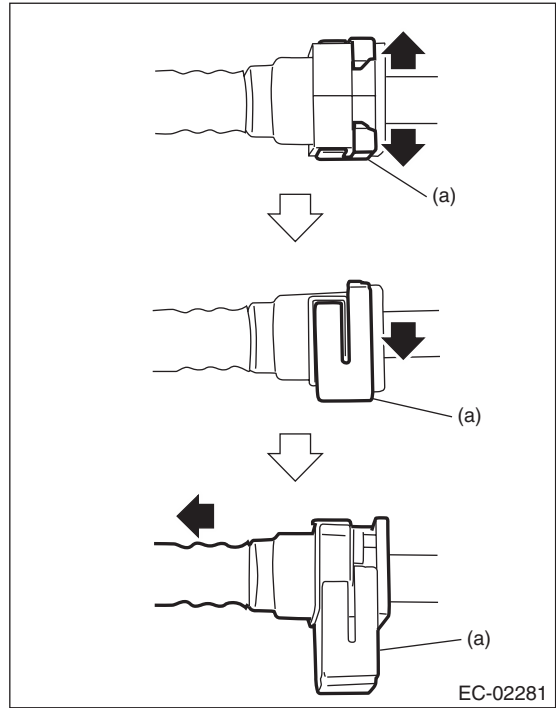

(a) Retainer

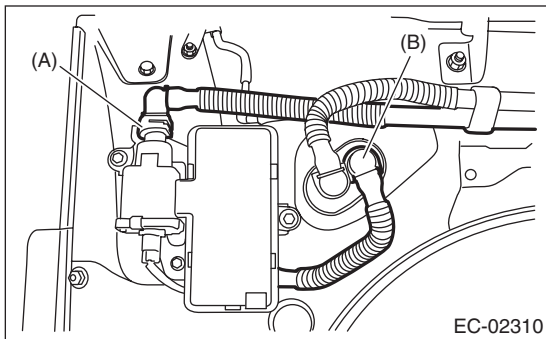

15) Disconnect connector (C) from the drain valve, and remove the drain valve.

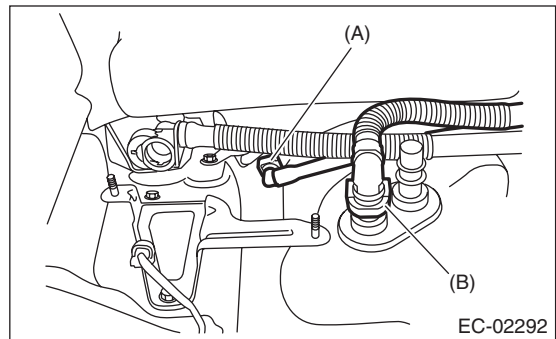
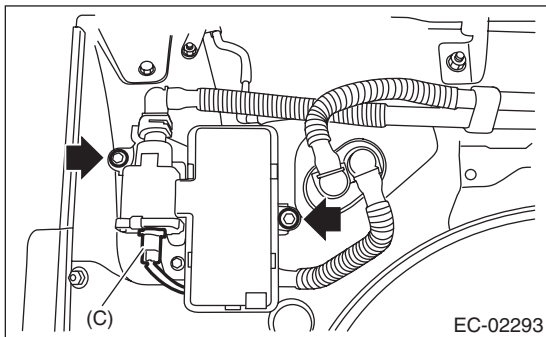

17) Remove purge tube (A), vent tube (B), and drain tube A (C).

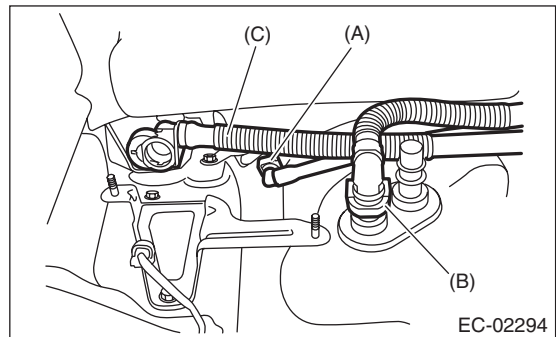

Canister

EMISSION CONTROL (AUX. EMISSION CONTROL DEVICES)

Brought to you by Eris Studios
NOT FOR RESALE

B: INSTALLATION

Install in the reverse order of removal while being careful of the following.

- Connect the quick connector as shown in the figure.

CAUTION:

- Check that there is no damage or dust on the quick connector. If necessary, clean seal surface of pipe.
- When connecting the quick connector, insert the pipe all the way in securely, then operate the push lock.
- If it is not possible to perform the push lock operation of the retainer, recheck whether the pipe is securely inserted.
- Confirm that the quick connector is securely connected.

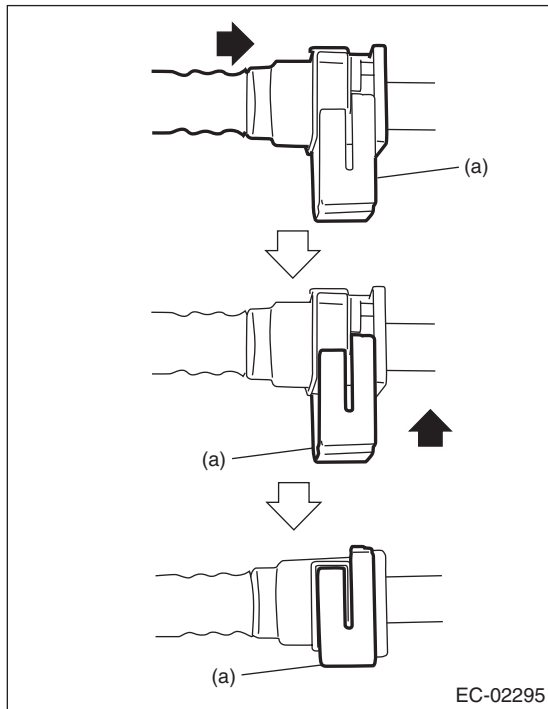

(a) Retainer

Tightening torque:

18 N·m (1.8 kgf-m, 13.3 ft-lb)

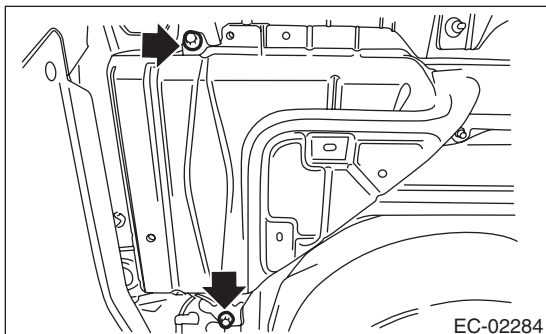

Tightening torque:

8 N·m (0.8 kgf-m, 5.9 ft-lb)

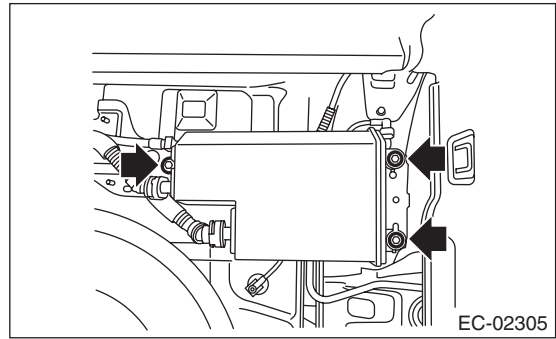

Tightening torque:

7.5 N·m (0.76 kgf-m, 5.5 ft-lb)

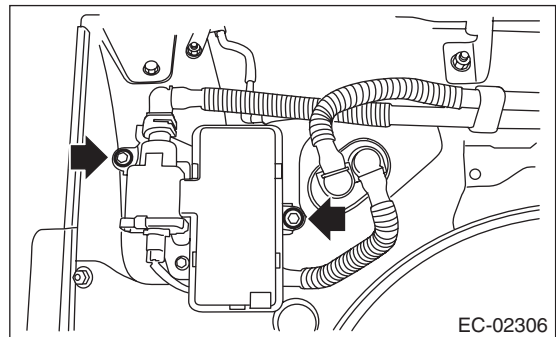

Tightening torque:

18 N·m (1.8 kgf-m, 13.3 ft-lb)

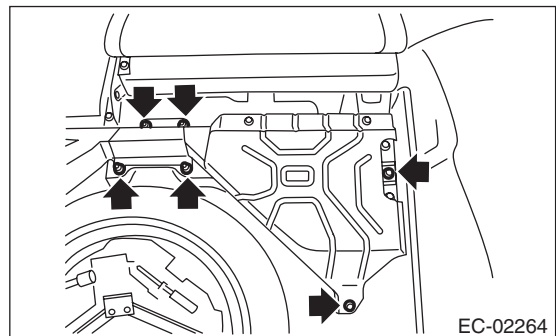

C: INSPECTION

Make sure that the canister, drain valve and tube are not cracked or loose.

Purge Control Solenoid Valve

EMISSION CONTROL (AUX. EMISSION CONTROL DEVICES)

Brought to you by *Travis Studios*
NOV 2007
RESALE

5. Purge Control Solenoid Valve

A: REMOVAL

1. PURGE CONTROL SOLENOID VALVE 1

1) Disconnect the ground cable from the battery.

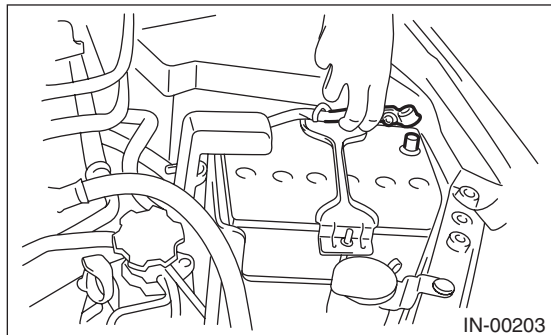

2) Remove the bolts that attach the purge control solenoid valve 1 to the intake manifold. Then disconnect the connector from the purge control solenoid valve 1.

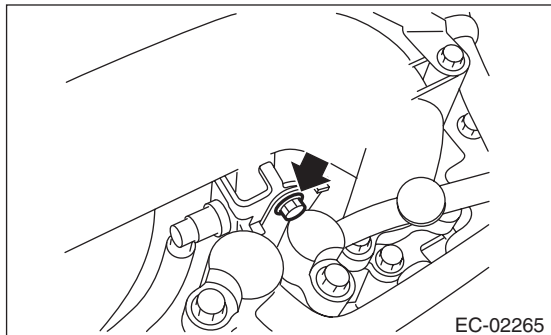

3) Disconnect the evaporation hose from the intake manifold and fuel pipe assembly.

2. PURGE CONTROL SOLENOID VALVE 2

1) Disconnect the ground cable from the battery.

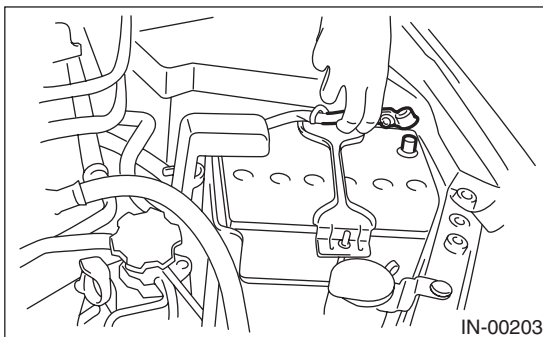

2) Remove the solenoid valve bracket assembly from intake manifold.

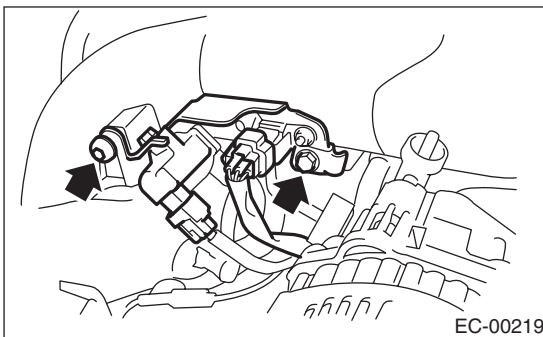

3) Disconnect the connector from purge control solenoid valve 2.

4) Disconnect the evaporation hose from the intake duct and fuel pipe assembly.

5) Remove the purge control solenoid valve 2 from the solenoid valve bracket assembly.

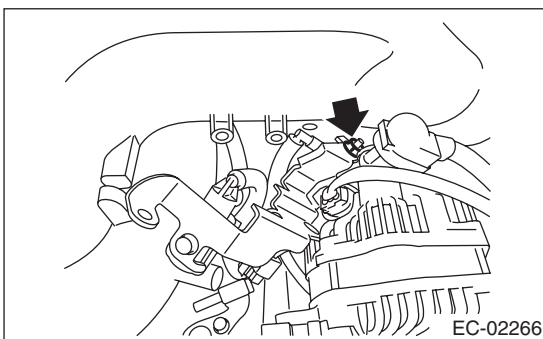

Purge Control Solenoid Valve

EMISSION CONTROL (AUX. EMISSION CONTROL DEVICES)

Brought to you by Eris Studios
NOT FOR RESALE

B: INSTALLATION

1. PURGE CONTROL SOLENOID VALVE 1

Install in the reverse order of removal.

NOTE:

Connect the evaporation hose as shown in the figure.

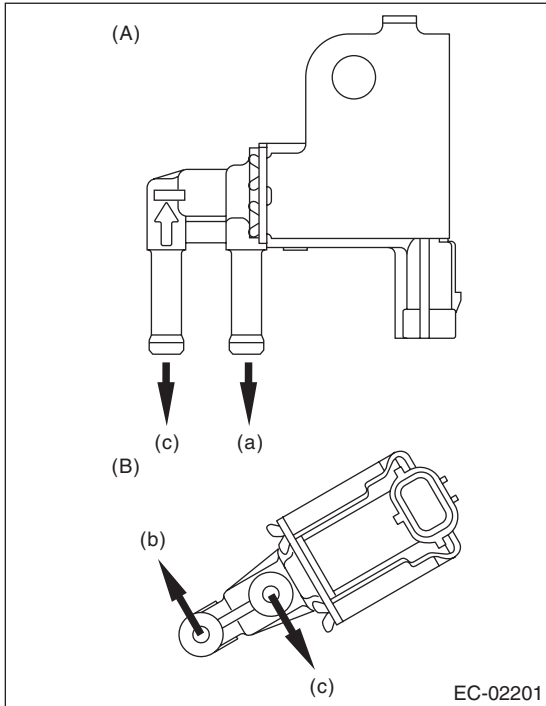

- (A) Purge Control Solenoid Valve 1
- (B) Purge Control Solenoid Valve 2
- (a) To intake manifold
- (b) To intake duct
- (c) To fuel pipe

Tightening torque:

6.4 N·m (0.65 kgf·m, 4.7 ft·lb)

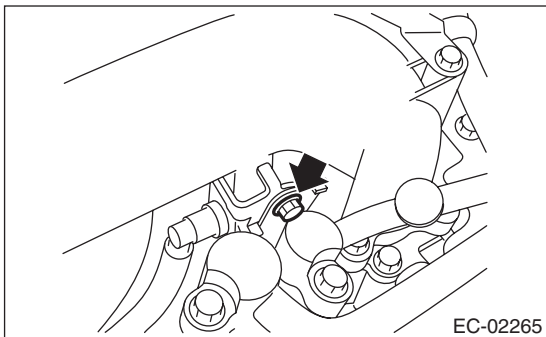

2. PURGE CONTROL SOLENOID VALVE 2

Install in the reverse order of removal.

NOTE:

Connect the evaporation hose as shown in the figure.

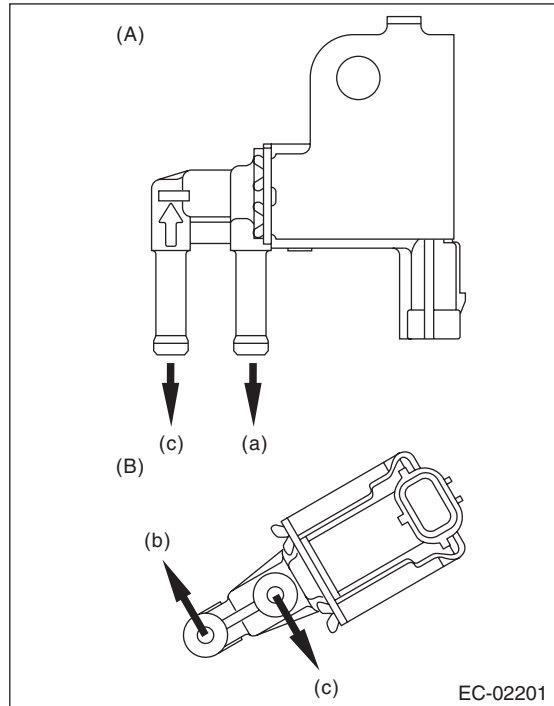

- (A) Purge Control Solenoid Valve 1
- (B) Purge Control Solenoid Valve 2
- (a) To intake manifold
- (b) To intake duct
- (c) To fuel pipe

Tightening torque:

6.4 N·m (0.65 kgf·m, 4.7 ft·lb)

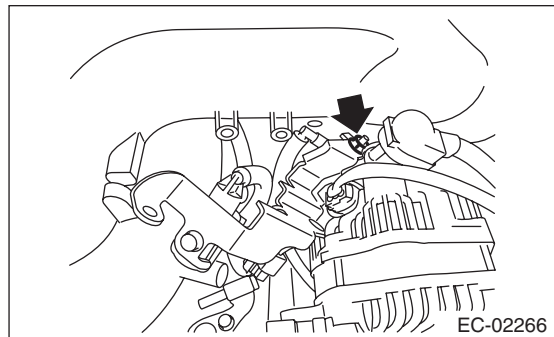

Purge Control Solenoid Valve

EMISSION CONTROL (AUX. EMISSION CONTROL DEVICES)

Brought to you by *Travis Studios*
NOT FOR SALE

Tightening torque:

T1: 17 N·m (1.7 kgf-m, 12.5 ft-lb)

T2: 19 N·m (1.9 kgf-m, 14.0 ft-lb)

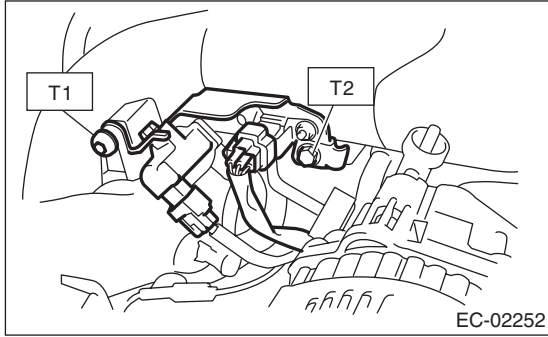

C: INSPECTION

Make sure the hoses are not cracked or loose.

Fuel Level Sensor

EMISSION CONTROL (AUX. EMISSION CONTROL DEVICES)

6. Fuel Level Sensor

A: REMOVAL

For removal procedures, refer to the "FU (H4DOTC)" section. <Ref. to FU(H4DOTC)-65, REMOVAL, Fuel Level Sensor.>

B: INSTALLATION

For installation procedures, refer to the "FU (H4DOTC)" section. <Ref. to FU(H4DOTC)-65, INSTALLATION, Fuel Level Sensor.>

Brought to you by Eris Studios
NOT FOR RESALE

Fuel Temperature Sensor

EMISSION CONTROL (AUX. EMISSION CONTROL DEVICES)

Brought to you by
E-TRIS Studios
NOT FOR SALE

7. Fuel Temperature Sensor

A: REMOVAL

The fuel temperature sensor is integrated into the fuel level sensor as one unit; therefore, refer to “Fuel Level Sensor” for removal procedures. <Ref. to FU(H4DOTC)-65, REMOVAL, Fuel Level Sensor.>

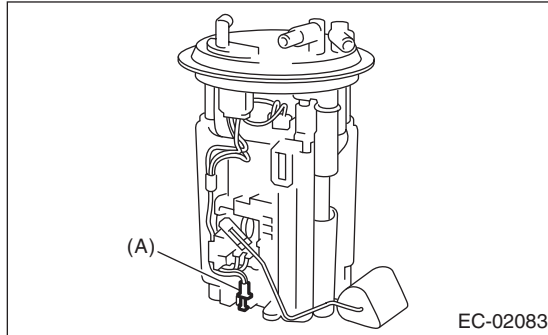

(A) Fuel temperature sensor

B: INSTALLATION

The fuel temperature sensor and fuel level sensor are integrated into one unit; therefore, refer to “Fuel Level Sensor” for installation procedure. <Ref. to FU(H4DOTC)-65, INSTALLATION, Fuel Level Sensor.>

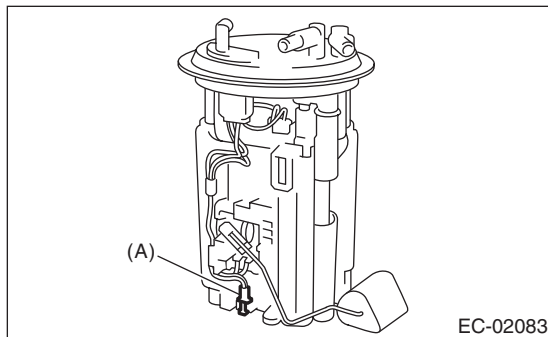

(A) Fuel temperature sensor

Fuel Sub Level Sensor

EMISSION CONTROL (AUX. EMISSION CONTROL DEVICES)

Brought to you by Eris Studios
NOT FOR RESALE

8. Fuel Sub Level Sensor

A: REMOVAL

For removal procedures, refer to the “FU (H4DOTC)” section. <Ref. to FU(H4DOTC)-66, REMOVAL, Fuel Sub Level Sensor.>

B: INSTALLATION

For installation procedures, refer to the “FU (H4DOTC)” section. <Ref. to FU(H4DOTC)-67, INSTALLATION, Fuel Sub Level Sensor.>

Fuel Tank Pressure Sensor

EMISSION CONTROL (AUX. EMISSION CONTROL DEVICES)

Brought to you by *3D CAD Studio*
NO COPYRIGHT SALE

9. Fuel Tank Pressure Sensor

A: REMOVAL

WARNING:

Place "NO OPEN FLAMES" signs near the working area.

- 1) Set the vehicle on a lift.
- 2) Disconnect the ground cable from the battery.

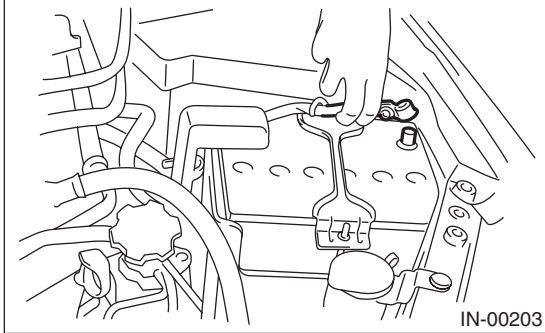

- 3) Open the fuel flap lid, and remove the fuel filler cap.
- 4) Lift up the vehicle.
- 5) Disconnect the connector from the fuel tank pressure sensor (A).
- 6) Disconnect the pressure hose from the fuel tank pressure sensor (B).
- 7) Remove the fuel tank pressure sensor along with the bracket.

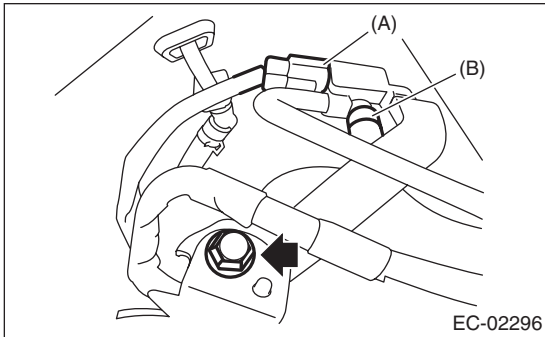

- 8) Remove the fuel pressure sensor from the bracket.

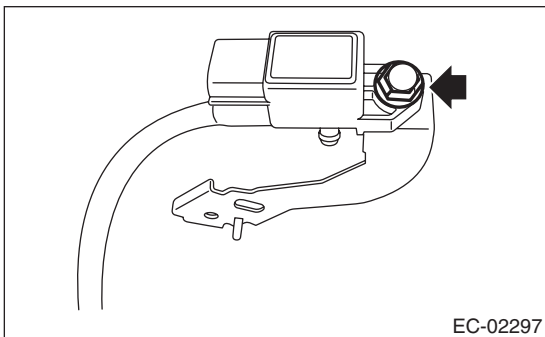

B: INSTALLATION

Install in the reverse order of removal.

Tightening torque:

7.35 N·m (0.76 kgf-m, 5.5 ft-lb)

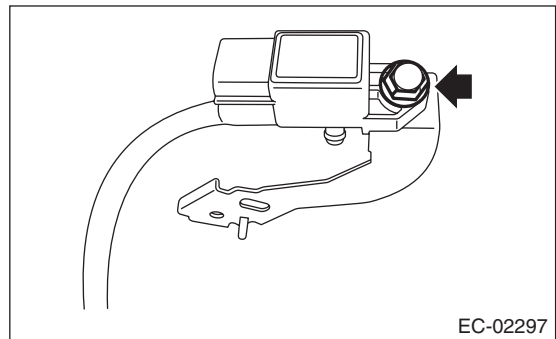
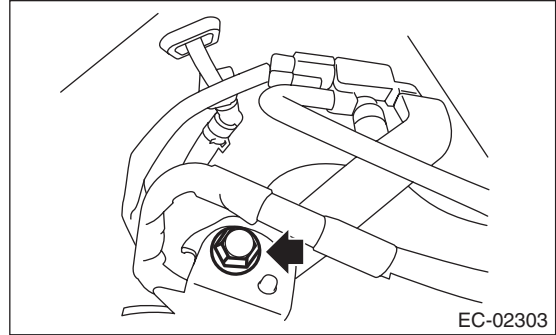

C: INSPECTION

Make sure the hoses are not cracked or loose.

Pressure Control Solenoid Valve

EMISSION CONTROL (AUX. EMISSION CONTROL DEVICES)

Brought to you by Eris Studios
NOT FOR RESALE

10. Pressure Control Solenoid Valve

A: REMOVAL

- 1) Set the vehicle on a lift.
- 2) Disconnect the ground cable from the battery.

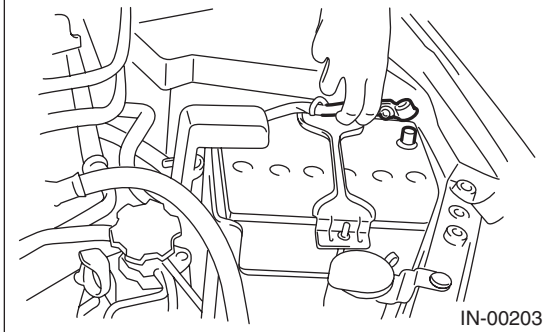

- 3) Lift up the vehicle.
- 4) Disconnect connector (A) from the pressure control solenoid valve.
- 5) Disconnect the evaporation hose (B) from the pressure control solenoid valve.
- 6) Remove the bolts (C) which secure the bracket to the fuel tank.

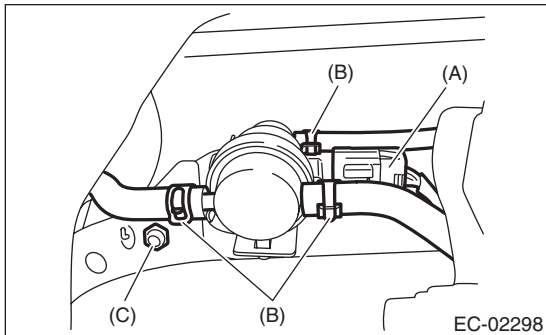

- 7) Remove the pressure control solenoid valve and bracket as a unit.
- 8) Remove the pressure control solenoid valve from the bracket.

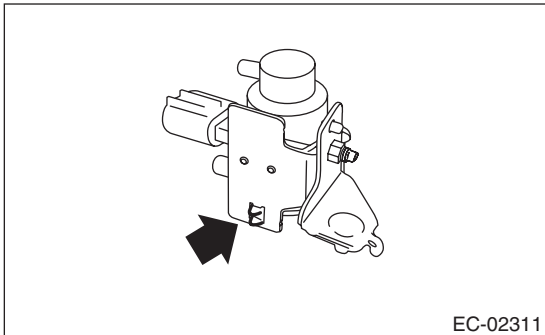

B: INSTALLATION

Install in the reverse order of removal.

Tightening torque:

7.35 N·m (0.76 kgf-m, 5.5 ft-lb)

C: INSPECTION

Make sure the hoses are not cracked or loose.

11.Drain Filter

A: SPECIFICATION

The drain valve is a non-disassembled part, so do not remove the drain filter from drain valve. Refer to "Canister" for removal and installation procedures.
<Ref. to EC(H4DOTC)-7, REMOVAL, Canister.>
<Ref. to EC(H4DOTC)-10, INSTALLATION, Canister.>

Shut Valve

EMISSION CONTROL (AUX. EMISSION CONTROL DEVICES)

Brought to you by Eris Studios
NOT FOR RESALE

12. Shut Valve

A: REMOVAL

WARNING:

Place "NO OPEN FLAMES" signs near the working area.

CAUTION:

Be careful not to spill fuel.

- 1) Remove the fuel filler pipe.
<Ref. to FU(H4DOTC)-59, REMOVAL, Fuel Filler Pipe.>
- 2) Disconnect the evaporation hose from the shut valve.

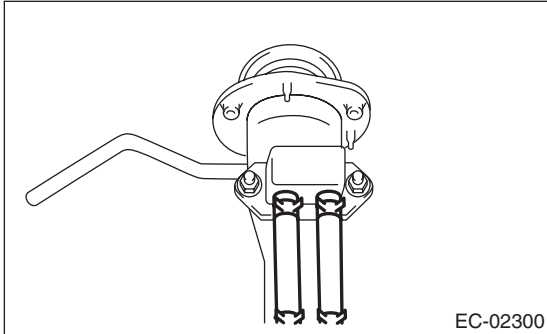

- 3) Remove the shut valve from the fuel filler pipe.

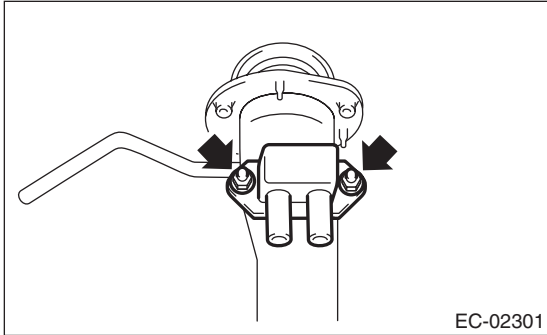

B: INSTALLATION

Install in the reverse order of removal.

Tightening torque:

4.5 N·m (0.46 kgf-m, 3.3 ft-lb)

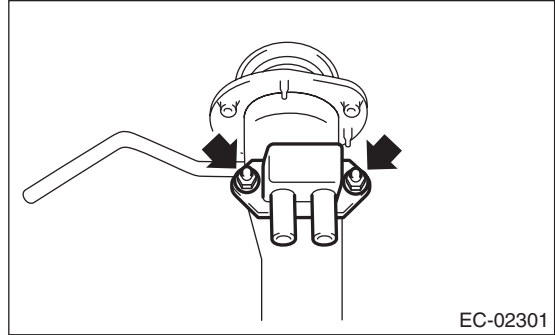

C: INSPECTION

Make sure the hoses are not cracked or loose.

13.Drain Valve

A: REMOVAL

Refer to "Canister" for removal procedures. <Ref. to EC(H4DOTC)-7, REMOVAL, Canister.>

B: INSTALLATION

Refer to "Canister" for installation procedures. <Ref. to EC(H4DOTC)-10, INSTALLATION, Canister.>

PCV Hose Assembly

EMISSION CONTROL (AUX. EMISSION CONTROL DEVICES)

Brought to you by Eris Studios
NOT FOR RESALE

14.PCV Hose Assembly

A: REMOVAL

CAUTION:

Do not remove unless the PCV hose, diagnostics connector and PCV valve are damaged.

- 1) Remove the intake manifold.
<Ref. to FU(H4DOTC)-15, REMOVAL, Intake Manifold.>
- 2) Remove the secondary air combination valve RH.
<Ref. to EC(H4DOTC)-24, SECONDARY AIR COMBINATION VALVE RH, REMOVAL, Secondary Air Combination Valve.>
- 3) Fit the depression in the ST with the protrusion on the clamp to unlock.
- 4) Remove the PCV hose assembly.
ST 18353AA000 CLAMP PLIERS

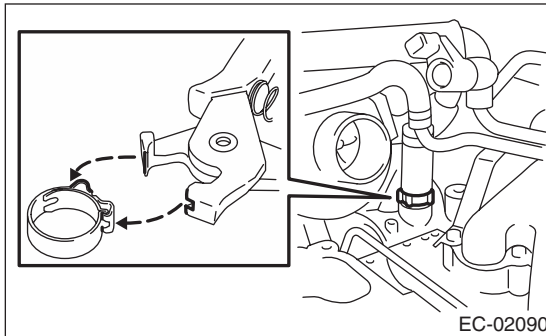

B: INSTALLATION

NOTE:

Use a new clamp.

- 1) Install the PCV hose assembly, then lock by fitting the ST on the clamp protrusion.
ST 18353AA000 CLAMP PLIERS

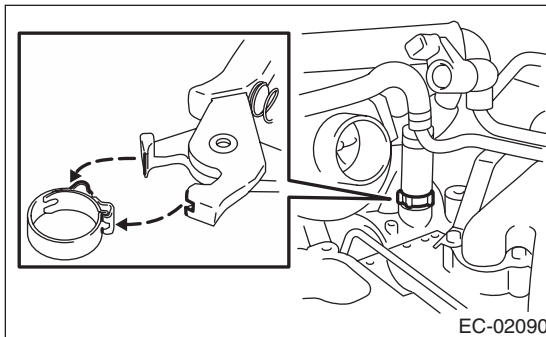

- 2) Install the secondary air combination valve RH.
<Ref. to EC(H4DOTC)-25, SECONDARY AIR COMBINATION VALVE RH, INSTALLATION, Secondary Air Combination Valve.>
- 3) Install the intake manifold.
<Ref. to FU(H4DOTC)-18, INSTALLATION, Intake Manifold.>

Secondary Air Pump

EMISSION CONTROL (AUX. EMISSION CONTROL DEVICES)

Brought to you by *Travis Studios*
NOX
RESALE

15. Secondary Air Pump

A: REMOVAL

1) Disconnect the ground cable from the battery.

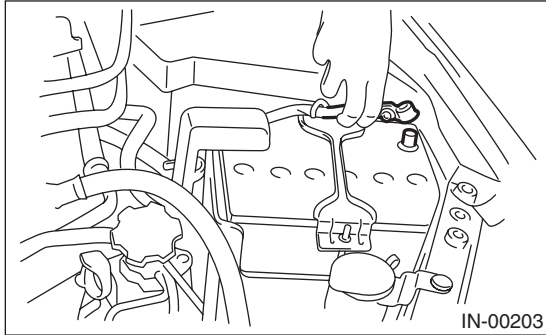

2) Disconnect the connector (A) from secondary air pump, and remove the harness.

3) Disconnect the hose (B) from secondary air pump.

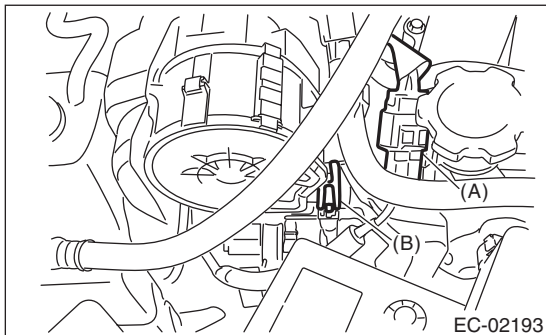

4) Remove the bolt (C) which secures the secondary air pump to the body.

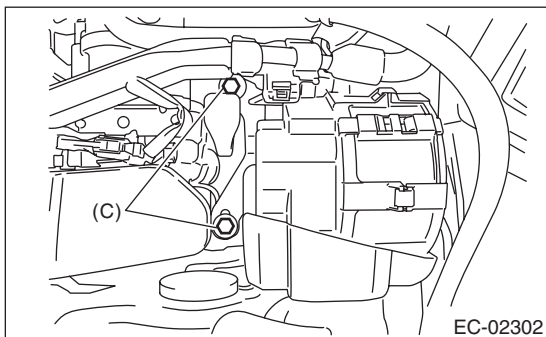

B: INSTALLATION

Install in the reverse order of removal.

Tightening torque:

19 N·m (1.9 kgf-m, 14.0 ft-lb)

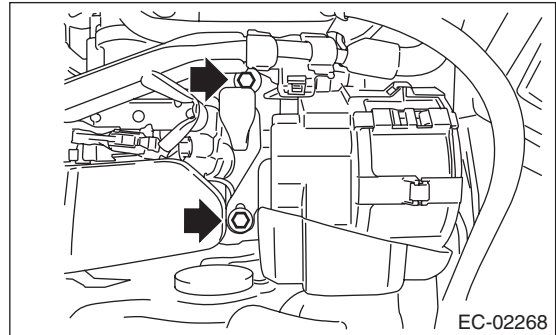

C: INSPECTION

Make sure the hoses are not cracked or loose.

Secondary Air Combination Valve

EMISSION CONTROL (AUX. EMISSION CONTROL DEVICES)

Brought to you by Eris Studios
NOT FOR RESALE

16. Secondary Air Combination Valve

A: REMOVAL

1. SECONDARY AIR COMBINATION VALVE LH

1) Disconnect the ground cable from the battery.

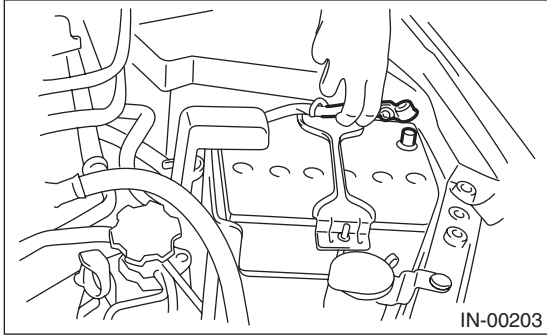

- 2) Remove the intercooler. <Ref. to IN(H4DOTC)-11, REMOVAL, Intercooler.>
- 3) Disconnect the connector from the secondary air combination valve LH.
- 4) Disconnect the air duct A.
- 5) Remove the secondary air pipe LH.
- 6) Remove the secondary air combination valve LH.

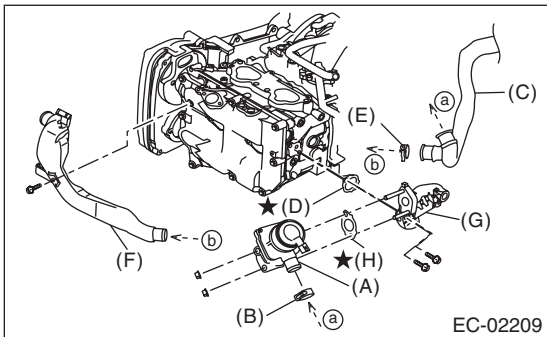

- (A) Secondary air combination valve LH
- (B) Clamp
- (C) Air duct A
- (D) Gasket
- (E) Clamp
- (F) Air duct B
- (G) Secondary air pipe LH
- (H) Gasket

2. SECONDARY AIR COMBINATION VALVE RH

1) Disconnect the ground cable from the battery.

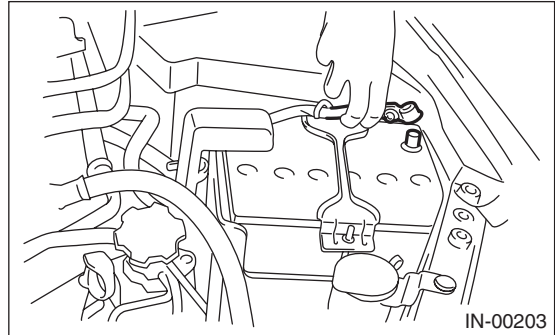

- 2) Remove the intercooler. <Ref. to IN(H4DOTC)-11, REMOVAL, Intercooler.>
- 3) Remove the intake manifold. <Ref. to FU(H4DOTC)-15, REMOVAL, Intake Manifold.>
- 4) Disconnect the connector from the secondary air combination valve RH.
- 5) Disconnect the air duct A.
- 6) Remove the secondary air pipe RH.
- 7) Remove the secondary air combination valve RH.

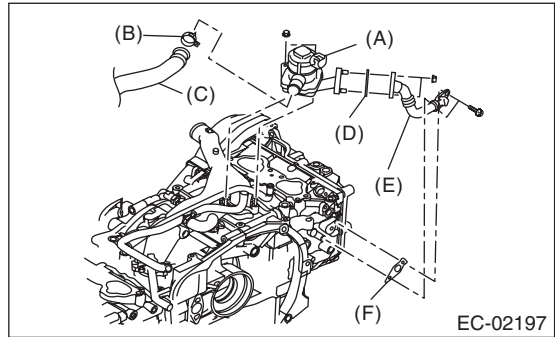

- (A) Secondary air combination valve RH
- (B) Clamp
- (C) Air duct A
- (D) Gasket
- (E) Secondary air pipe RH
- (F) Gasket

Secondary Air Combination Valve

EMISSION CONTROL (AUX. EMISSION CONTROL DEVICES)

Brought to you by *Travis Studios*
NO COPY RESALE

B: INSTALLATION

1. SECONDARY AIR COMBINATION VALVE LH

Install in the reverse order of removal.

NOTE:

Use a new gasket.

Tightening torque:

T1: 9 N·m (0.9 kgf-m, 6.6 ft-lb)

T2: 19 N·m (1.9 kgf-m, 14.0 ft-lb)

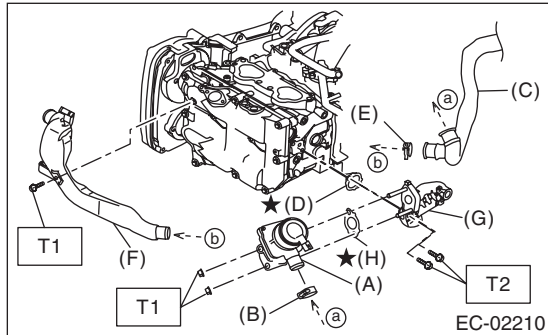

- (A) Secondary air combination valve LH
- (B) Clamp
- (C) Air duct A
- (D) Gasket
- (E) Clamp
- (F) Air duct B
- (G) Secondary air pipe LH
- (H) Gasket

2. SECONDARY AIR COMBINATION VALVE RH

Install in the reverse order of removal.

NOTE:

Use a new gasket.

Tightening torque:

T1: 6.4 N·m (0.65 kgf-m, 4.7 ft-lb)

T2: 9 N·m (0.9 kgf-m, 6.6 ft-lb)

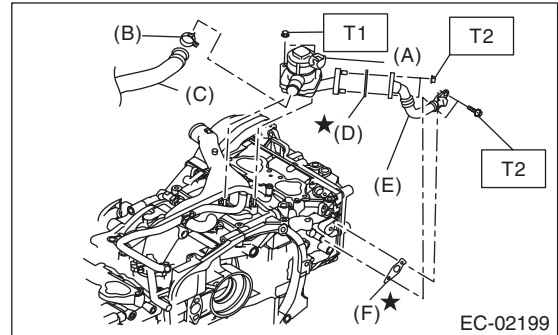

- (A) Secondary air combination valve RH
- (B) Clamp
- (C) Air duct A
- (D) Gasket
- (E) Secondary air pipe RH
- (F) Gasket

C: INSPECTION

Check the air duct and pipe for looseness.

Secondary Air Combination Valve

EMISSION CONTROL (AUX. EMISSION CONTROL DEVICES)

Brought to you by Eris Studios
NOT FOR RESALE