

Brought to you by Eris Studios
NOT FOR RESALE

LUBRICATION

General Description

LUBRICATION

Brought to you by Eris Studios
NOT FOR RESALE

1. General Description

A: SPECIFICATION

Lubrication method			Forced lubrication		
Oil pump	Pump type		Trochoid type		
	Number of teeth	Inner rotor	9		
		Outer rotor	10		
	Outer rotor diameter × thickness		mm (in)	76 × 10 (2.99 × 0.47)	
	Tip clearance between inner and outer rotors		mm (in)	0.04 — 0.14 (0.0016 — 0.0055)	
	Side clearance between inner rotor and pump case		mm (in)	0.02 — 0.07 (0.0008 — 0.0028)	
	Case clearance between outer rotor and pump case		Standard mm (in)	0.10 — 0.175 (0.0039 — 0.0069)	
	Performance (Oil temperature 80°C (176°F))	600 rpm	Discharge pressure	kPa (kg/cm ² , psi)	98 (1.0, 14)
			Discharge rate	ℓ (US qt, Imp qt)/min.	4.6 (4.9, 4.0) or more
		5,000 rpm	Discharge pressure	kPa (kg/cm ² , psi)	294 (3.0, 43)
Discharge rate			ℓ (US qt, Imp qt)/min.	47.0 (49.7, 41.4) or more	
Relief valve working pressure		kPa (kg/cm ² , psi)	588 (6.0, 85)		
Oil filter	Filter type		Full-flow filter type		
	Filtration area	cm ² (sq in)	Outer diameter: 68 mm (2.68 in)	800 (124)	
			Outer diameter: 65 mm (2.56 in)	470 (72.9)	
	By-pass valve opening pressure		kPa (kg/cm ² , psi)	160 (1.63, 23.2)	
	Outer diameter × width	mm (in)	Outer diameter: 68 mm (2.68 in)	68 × 65 (2.68 × 2.56)	
			Outer diameter: 65 mm (2.56 in)	65 × 74.4 (2.56 × 2.93)	
Installation screw specifications			M 20 × 1.5		
Oil pressure switch	Type		Immersed contact point type		
	Operating voltage — power consumption		12 V — 3.4 W or less		
	Warning light operating pressure		kPa (kg/cm ² , psi)	14.7 (0.15, 2.1)	
	Proof pressure		kPa (kg/cm ² , psi)	981 (10, 142) or more	
Engine oil	Total capacity (Overhaul)		ℓ (US qt, Imp qt)	5.0 (5.3, 4.4)	
	When replacing engine oil and oil filter		ℓ (US qt, Imp qt)	4.2 (4.4, 3.7)	
	When replacing engine oil only		ℓ (US qt, Imp qt)	4.0 (4.2, 3.5)	

Recommended oil:

Items having the API standard SM “Energy Conserving” logo or ILSAC standard GF-4 “Star burst mark” label on the container.

SAE (1)							
(°C)	-30	-20	-15	0	15	30	40
(°F)	-22	-4	5	32	59	86	104
LU-02329							

- (1) SAE viscosity No. and applicable temperature
- (2) Recommended

The proper viscosity oil helps the engine maintain its ideal temperature, and cranking speed increased by reducing viscosity friction in hot condition.

CAUTION:

It is acceptable to fill an engine with oil of another brand when replacing the oil, but make sure to use an oil with an API standard and SAE viscosity number specified by Subaru.

NOTE:

If the vehicle is used in regions with high temperatures or in other severe environments, use oil with the viscosities shown below. API standard: SM or SL

SAE Viscosity No.: 30, 40, 10W-50, 20W-40, 20W-50

General Description

LUBRICATION

Brought to you by Eris Studios
NOT FOR RESALE

B: COMPONENT

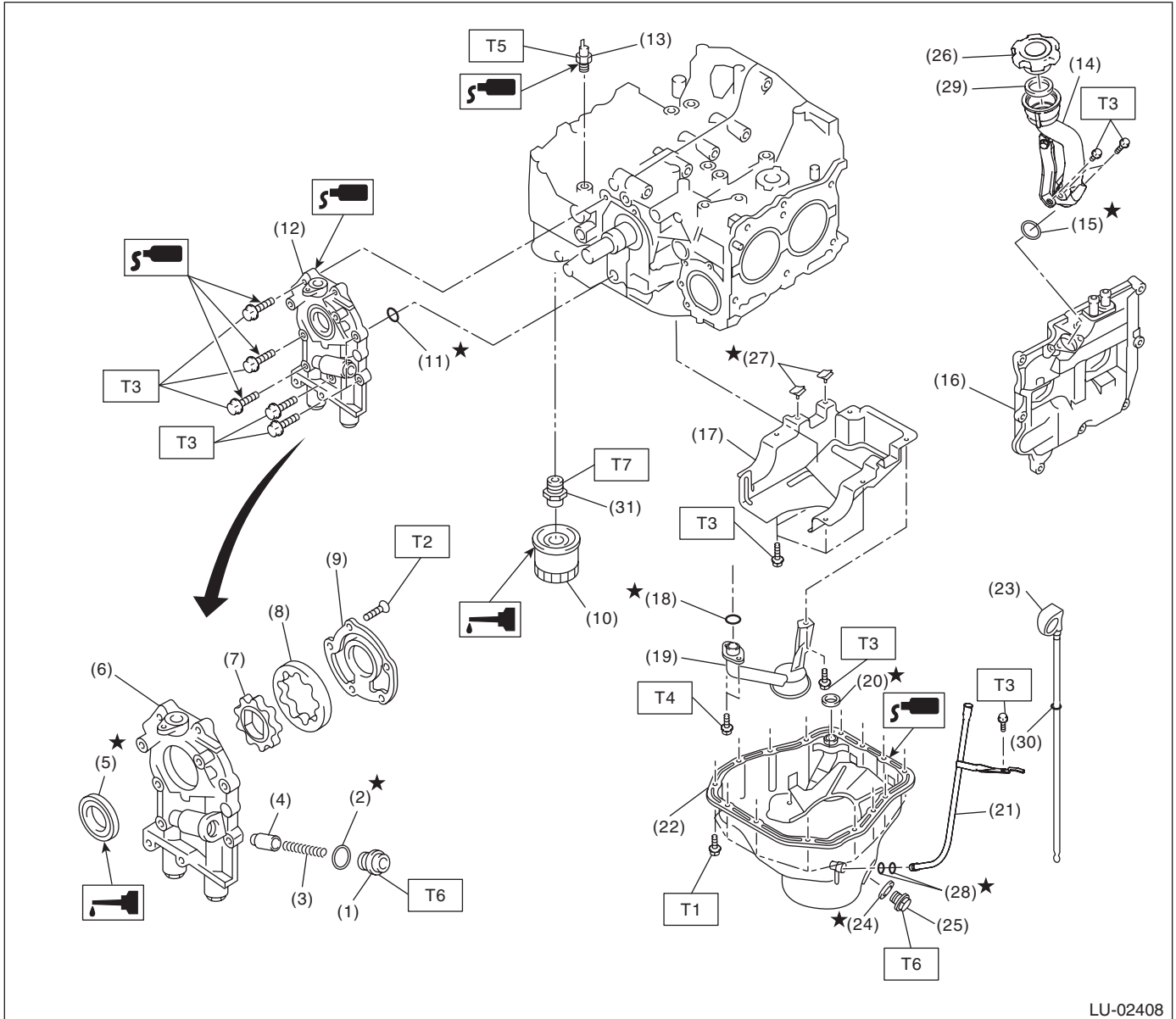

LU-02408

- | | | |
|--------------------------|----------------------------|---------------------------|
| (1) Plug | (15) O-ring | (29) Gasket |
| (2) Gasket | (16) Rocker cover | (30) O-ring |
| (3) Relief valve spring | (17) Baffle plate | (31) Oil filter connector |
| (4) Relief valve | (18) O-ring | |
| (5) Front oil seal | (19) Oil strainer | |
| (6) Oil pump case | (20) Gasket | |
| (7) Inner rotor | (21) Oil level gauge guide | |
| (8) Outer rotor | (22) Oil pan | |
| (9) Oil pump cover | (23) Oil level gauge | |
| (10) Oil filter | (24) Drain plug gasket | |
| (11) O-ring | (25) Drain plug | |
| (12) Oil pump ASSY | (26) Oil filler cap | |
| (13) Oil pressure switch | (27) Seal | |
| (14) Oil filler duct | (28) O-ring | |

Tightening torque: N·m (kgf·m, ft·lb)

- | | |
|------------|------------------------|
| T1: | 5 (0.5, 3.7) |
| T2: | 5.4 (0.55, 4.0) |
| T3: | 6.4 (0.65, 4.7) |
| T4: | 10 (1.0, 7.0) |
| T5: | 25 (2.5, 18.4) |
| T6: | 44 (4.5, 32.5) |
| T7: | 45 (4.6, 33.2) |

LU(H4DOTC)-4

General Description

Brought to you by *Pro's Studios*
 NOT FOR RESALE
LUBRICATION

C: CAUTION

- Wear appropriate work clothing, including a cap, protective goggles and protective shoes when performing any work.
- Remove contamination including dirt and corrosion before removal, installation or disassembly.
- Keep the disassembled parts in order and protect them from dust and dirt.
- Before removal, installation or disassembly, be sure to clarify the failure. Avoid unnecessary removal, installation, disassembly and replacement.

- Vehicle components are extremely hot after driving. Be wary of receiving burns from heated parts.
- Be sure to tighten fasteners including bolts and nuts to the specified torque.
- Place shop jacks or rigid racks at the specified points.
- Before disconnecting connectors of sensors or units, be sure to disconnect the ground cable from the battery.
- If the engine oil is spilt over exhaust pipe or the under cover, wipe it off with cloth to avoid emitting smoke or causing a fire.

D: PREPARATION TOOL

1. SPECIAL TOOL

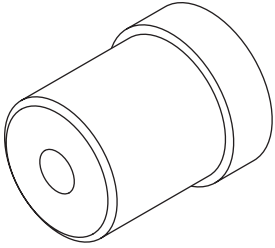
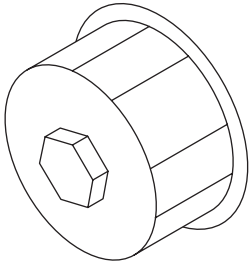
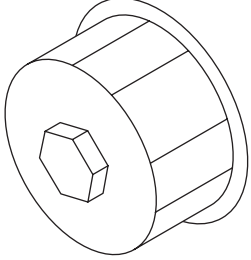
ILLUSTRATION	TOOL NUMBER	DESCRIPTION	REMARKS
 <p>ST-499587100</p>	499587100	OIL SEAL INSTALLER	Used for installing oil seal into oil pump.
 <p>ST18332AA000</p>	18332AA000	OIL FILTER WRENCH	Used for removing and installing oil filter. (Outer diameter: 68 mm (2.68 in))
 <p>ST18332AA010</p>	18332AA010	OIL FILTER WRENCH	Used for removing and installing oil filter. (Outer diameter: 65 mm (2.56 in))

Oil Pressure System

LUBRICATION

Brought to you by Eris Studios
NOT FOR RESALE

2. Oil Pressure System

A: WIRING DIAGRAM

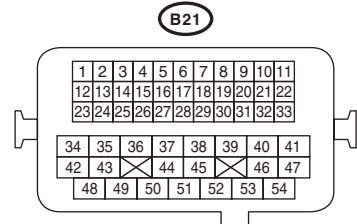
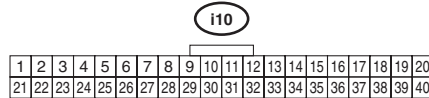
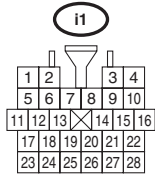
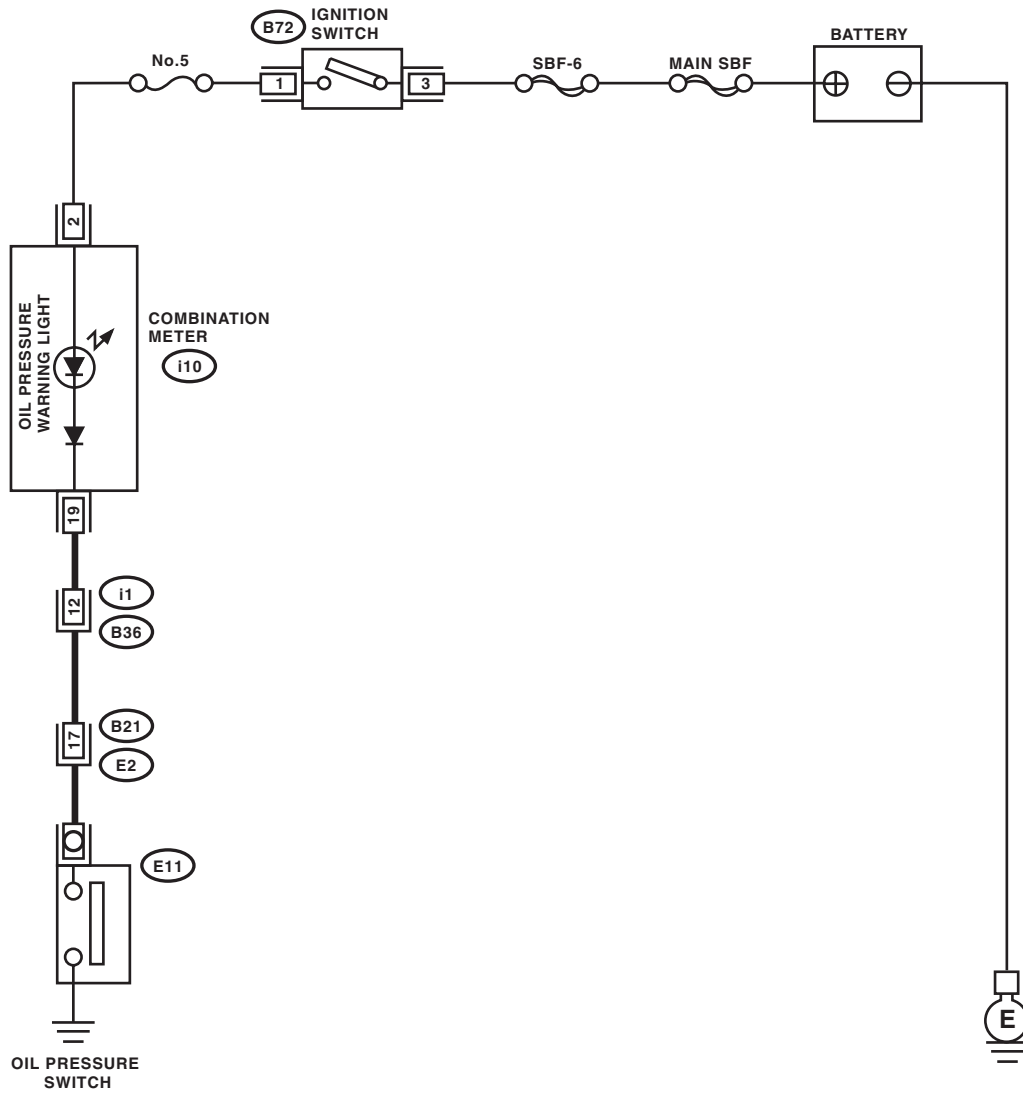

LU-02394

Oil Pressure System

Brought to you by Pro's Studios
 NO PARTS FOR SALE
LUBRICATION

B: INSPECTION

Step	Check	Yes	No
1 CHECK COMBINATION METER. 1) Turn the ignition switch to ON. (engine OFF) 2) Check the warning light in the combination meter.	Does the warning light illuminate?	Go to step 2.	Repair or replace the combination meter. <Ref. to IDI-4, INSPECTION, Combination Meter System.>
2 CHECK HARNESS CONNECTOR BETWEEN COMBINATION METER AND OIL PRESSURE SWITCH. 1) Turn the ignition switch to OFF. 2) Disconnect the connector from oil pressure switch. 3) Turn the ignition switch to ON. 4) Measure the voltage of harness between oil pressure switch connector and chassis ground. Connector & terminal (E11) No. 1 (+) — Chassis ground (-):	Is the voltage 10 V or more?	Replace the oil pressure switch.	Go to step 3.
3 CHECK COMBINATION METER. 1) Turn the ignition switch to OFF. 2) Remove the combination meter. 3) Measure the resistance of combination meter. Terminals (i10) No. 2 — No. 19:	Is the resistance less than 10 Ω ?	Repair the harness and connector. NOTE: In this case, repair the following item: • Open circuit of harness between combination meter and oil pressure switch • Poor contact in combination meter connector • Poor contact in oil pressure switch connector • Poor contact of coupling connector	Repair or replace the combination meter. <Ref. to IDI-4, INSPECTION, Combination Meter System.>

3. Engine Oil

A: INSPECTION

CAUTION:

If the engine oil is spilt over exhaust pipe or the under cover, wipe it off with cloth to avoid emitting smoke or causing a fire.

- 1) Park the vehicle on a level surface.
- 2) Remove the oil level gauge and wipe away the oil.
- 3) Reinsert the oil level gauge all the way. Be sure that the oil level gauge is correctly inserted and properly orientated.
- 4) Remove the oil level gauge again and check the reading. If the engine oil level is below "L" line, add oil to bring the level up to "F" line.
- 5) Start the engine and warm it up for a time.
- 6) After turning off the engine, wait a few minutes for the oil to return to the oil pan before checking the level.

NOTE:

- Just after driving or while the engine is warm, engine oil level shows in the range between "F" line and cutout portion. This is caused by thermal expansion of engine oil.
- To prevent overfilling of engine oil, do not add oil above "F" line when the engine is cold.
- As the oil level gauge is used for daily maintenance, the "F" line and "L" line is set assuming that the engine is cold.

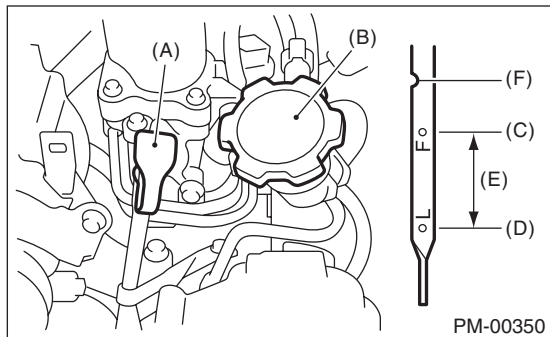

- (A) Oil level gauge
- (B) Engine oil filler cap
- (C) "F" line
- (D) "L" line
- (E) Approx. 1.0 ℓ (1.1 US qt, 0.9 Imp qt)
- (F) Notch mark

B: REPLACEMENT

CAUTION:

If the engine oil is spilt over exhaust pipe or the under cover, wipe it off with cloth to avoid emitting smoke or causing a fire.

- 1) Set the vehicle on a lift.
- 2) Open the engine oil filler cap for quick draining of engine oil.
- 3) Lift up the vehicle.
- 4) Drain engine oil by loosening the engine oil drain plug.

NOTE:

Prepare the container for draining of engine oil.

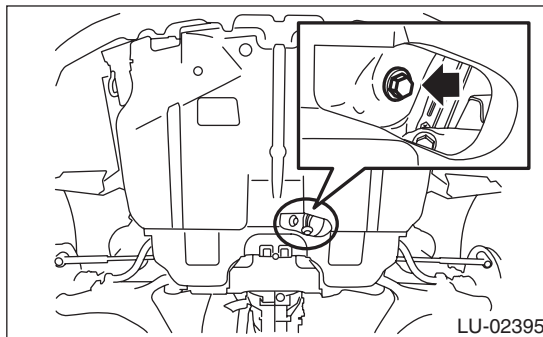

- 5) Tighten the engine oil drain plug after draining engine oil.

NOTE:

Use a new drain plug gasket.

Tightening torque:

44 N·m (4.5 kgf·m, 32.5 ft·lb)

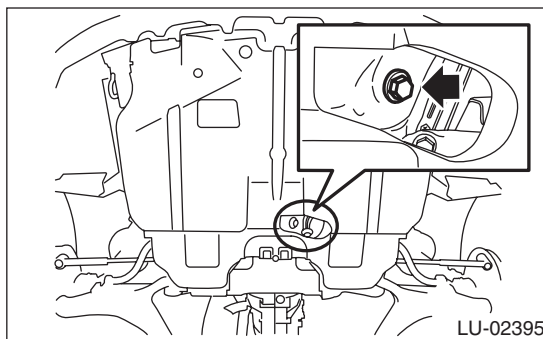

- 6) Lower the vehicle.
- 7) Using engine oil of proper quality and viscosity, fill engine oil through the oil filler duct to the "F" line on oil level gauge. Make sure that the vehicle is parked on a level surface when checking oil level.

Recommended oil:

Refer to "SPECIFICATION" for the recommended oil. <Ref. to LU(H4DOTC)-2, SPECIFICATION, General Description.>

Engine oil capacity:

Refer to "SPECIFICATION" for the engine oil capacity. <Ref. to LU(H4DOTC)-2, SPECIFICATION, General Description.>

Engine Oil

- 8) Close the engine oil filler cap.
- 9) Start the engine, and spreads the oil in engine room.
- 10) After the engine stops, recheck the oil level. If necessary, add engine oil up to the "F" line on oil level gauge.

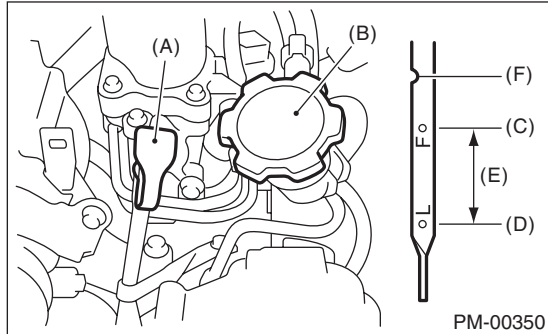

- (A) Oil level gauge
- (B) Engine oil filler cap
- (C) "F" line
- (D) "L" line
- (E) Approx. 1.0 ℓ (1.1 US qt, 0.9 Imp qt)
- (F) Notch mark

4. Oil Pump

A: REMOVAL

- 1) Set the vehicle on a lift.
- 2) Disconnect the ground cable from the battery.

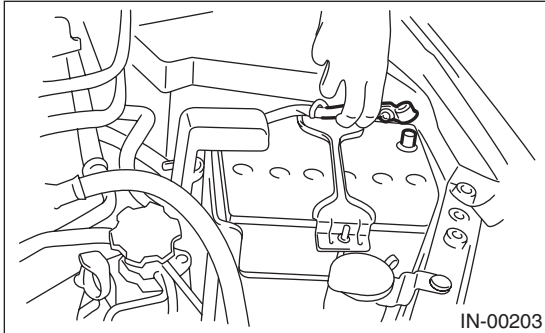

- 3) Lift up the vehicle.
- 4) Remove the under cover.
- 5) Lower the vehicle.
- 6) Remove the radiator. <Ref. to CO(H4DOTC)-19, REMOVAL, Radiator.>
- 7) Remove the crankshaft position sensor. <Ref. to FU(H4DOTC)-29, REMOVAL, Crankshaft Position Sensor.>
- 8) Remove the water pump. <Ref. to CO(H4DOTC)-15, REMOVAL, Water Pump.>
- 9) Remove the crank sprocket. <Ref. to ME(H4DOTC)-62, REMOVAL, Crank Sprocket.>

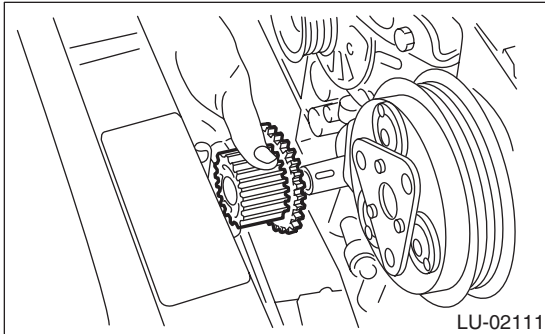

- 10) Remove the bolts which install oil pump onto cylinder block.

NOTE:

When disassembling and checking the oil pump, loosen the relief valve plug before removing the oil pump.

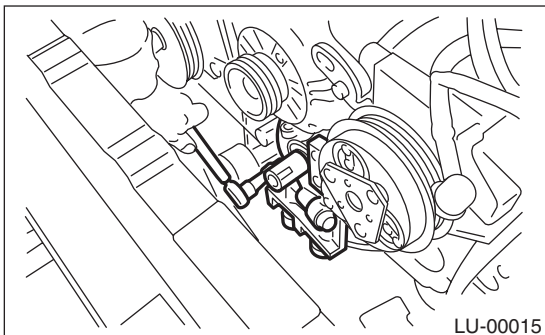

- 11) Remove the oil pump by using flat tip screwdriver.

CAUTION:

Be careful not to scratch mating surfaces of cylinder block and oil pump.

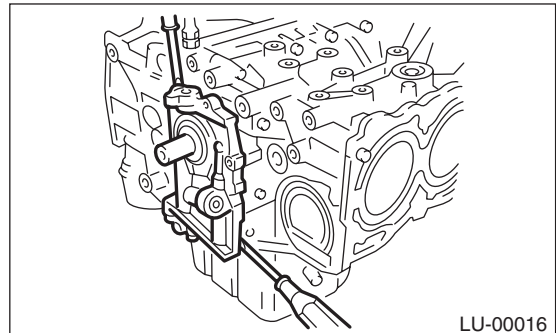

- 12) Remove the front oil seal from the oil pump.

B: INSTALLATION

- 1) Using the ST, install the front oil seal.
ST 499587100 OIL SEAL INSTALLER

NOTE:

Use a new front oil seal.

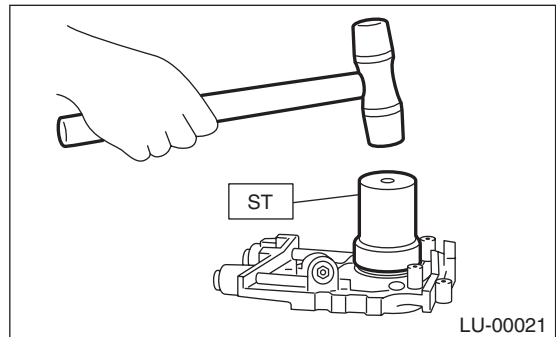

- 2) Apply liquid gasket to the mating surfaces of oil pump.

NOTE:

Install within 5 min. after applying liquid gasket.

Liquid gasket:

THREE BOND 1217G (Part No. K0877Y0100) or equivalent

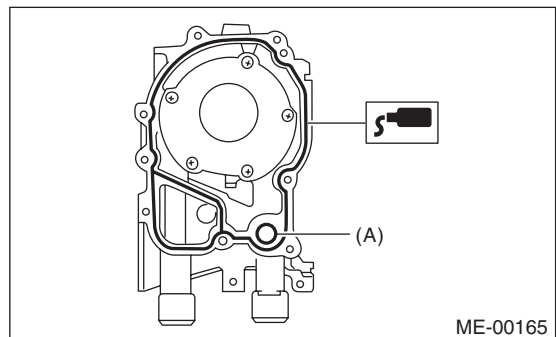

(A) O-ring

3) Apply a coat of engine oil to the inside of oil seal.

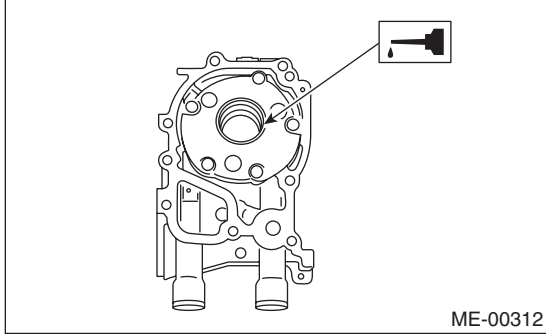

4) Install the oil pump to cylinder block. Be careful not to damage the oil seal during installation.

NOTE:

- Make sure the front oil seal lip is not folded.
- Align the flat surface of oil pump's inner rotor with crankshaft before installation.
- Use new O-rings.
- Do not forget to assemble O-rings.

5) Apply liquid gasket to the three bolts thread shown in figure. (when reuse the bolts)

Liquid gasket:

THREE BOND 1324 (Part No. 004403042) or equivalent

Tightening torque:

6.4 N·m (0.65 kgf-m, 4.7 ft-lb)

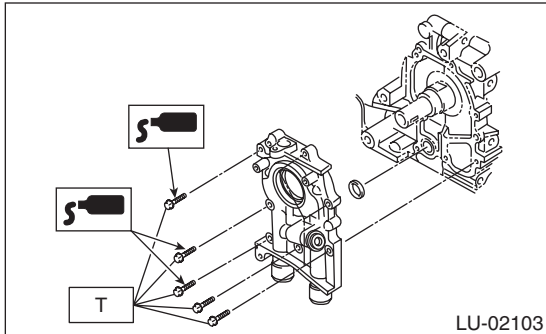

6) Install the crank sprocket. <Ref. to ME(H4DOTC)-62, INSTALLATION, Crank Sprocket.>

7) Install the water pump. <Ref. to CO(H4DOTC)-15, INSTALLATION, Water Pump.>

8) Install the crankshaft position sensor. <Ref. to FU(H4DOTC)-29, INSTALLATION, Crankshaft Position Sensor.>

9) Install the radiator. <Ref. to CO(H4DOTC)-20, INSTALLATION, Radiator.>

10) Lift up the vehicle.

11) Install the under cover.

12) Lower the vehicle.

13) Connect the ground cable to the battery.

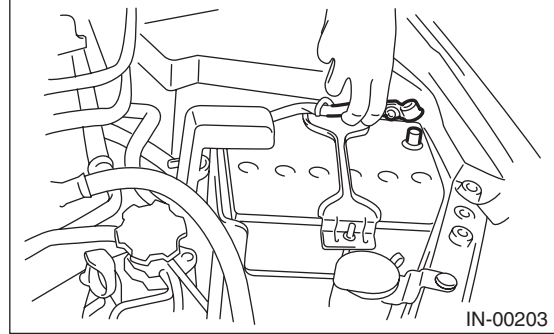

C: DISASSEMBLY

Remove the screw which secures oil pump cover and then disassemble oil pump. Inscribe alignment marks on the inner and outer rotors so that they can be replaced in their original positions during reassembly.

NOTE:

Before disassembling the oil pump, remove the relief valve.

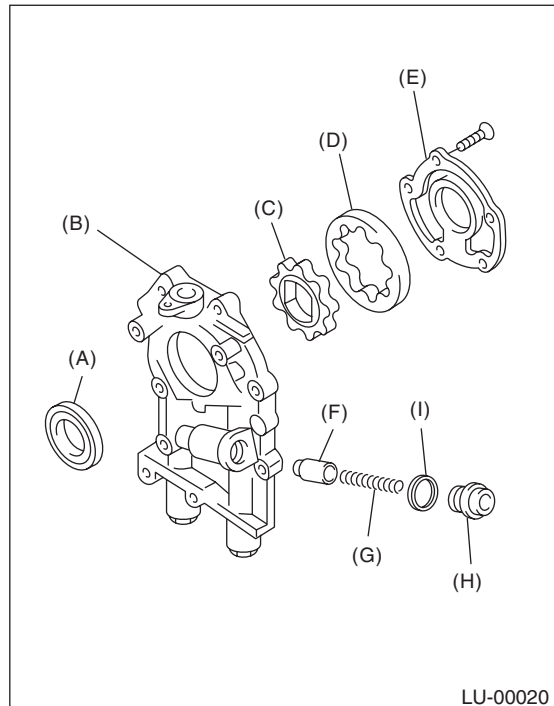

- (A) Front oil seal
- (B) Oil pump case
- (C) Inner rotor
- (D) Outer rotor
- (E) Oil pump cover
- (F) Relief valve
- (G) Relief valve spring
- (H) Plug
- (I) Gasket

Oil Pump

Brought to you by Eris Studios
NOT FOR RESALE

LUBRICATION

D: ASSEMBLY

1) Using the ST, install the front oil seal.
ST 499587100 OIL SEAL INSTALLER

NOTE:

Use a new front oil seal.

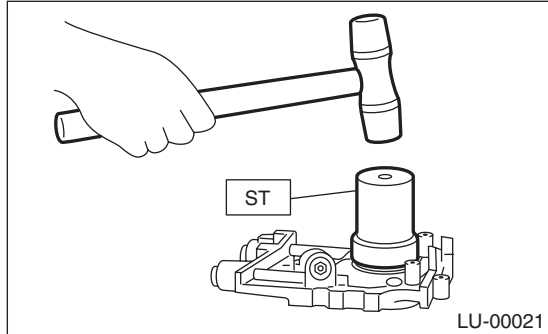

- 2) Apply a coat of engine oil to inner and outer rotors.
- 3) Assemble the inner and outer rotors in their original positions.
- 4) Assemble the oil relief valve and install relief valve spring and plug.

NOTE:

Use a new gasket.

5) Install the oil pump cover.

Tightening torque:

T1: 5.4 N·m (0.55 kgf-m, 4.0 ft-lb)

T2: 44 N·m (4.5 kgf-m, 32.5 ft-lb)

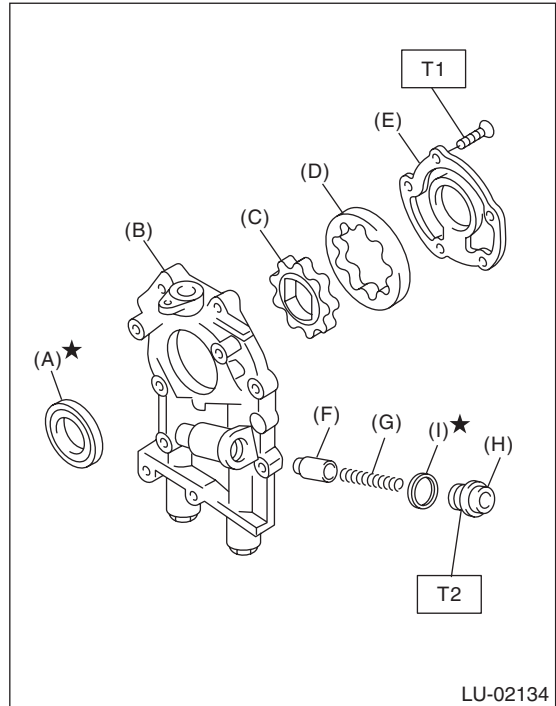

- (A) Front oil seal
- (B) Oil pump case
- (C) Inner rotor
- (D) Outer rotor
- (E) Oil pump cover
- (F) Relief valve
- (G) Relief valve spring
- (H) Plug
- (I) Gasket

E: INSPECTION**1. TIP CLEARANCE**

Measure the tip clearance of rotors. If the clearance is out of specification, replace the rotors as a set.

Tip clearance:**Standard**

0.04 — 0.14 mm (0.0016 — 0.0055 in)

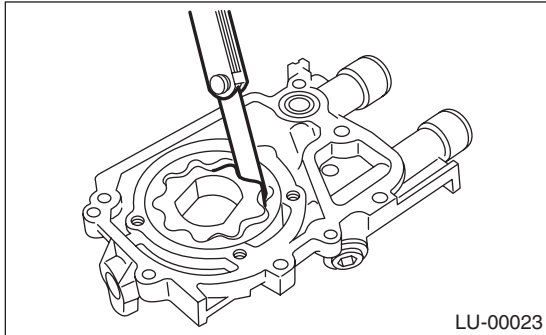
**2. CASE CLEARANCE**

Measure the clearance between the outer rotor and the oil pump case. If clearance is out of standard, replace the oil pump case.

Case clearance:**Standard**

0.10 — 0.175 mm (0.0039 — 0.0069 in)

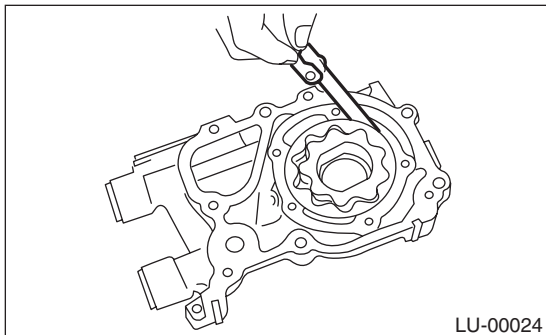
**3. SIDE CLEARANCE**

Measure the gap between the inner rotor and the oil pump case to measure the clearance between the inner rotor and the oil pump cover as shown in the figure. If the clearance is out of specification, replace the rotors and the oil pump case.

Side clearance:**Standard**

0.02 — 0.07 mm (0.0008 — 0.0028 in)

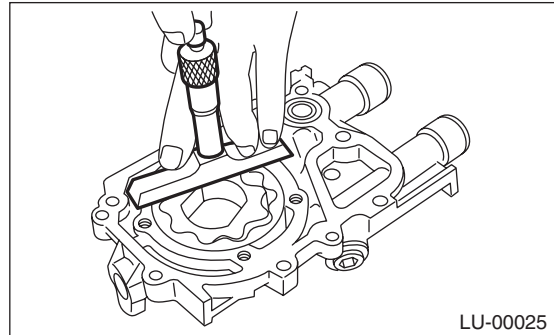
**4. OIL RELIEF VALVE**

Check the valve for assembly condition and damage, and the relief valve spring for damage and deterioration. Replace the parts if defective.

Relief valve spring:**Free length**

73.7 mm (2.902 in)

Installed length

54.7 mm (2.154 in)

Load when installed

93.1 N (9.49 kgf, 20.88 lbf)

5. OIL PUMP CASE

Check for worn shaft hole, clogged oil passage, worn rotor chamber, cracks and other faults.

6. FRONT OIL SEAL

Check the front oil seal lips for deformation and hardening, wear.

LUBRICATION

5. Oil Pan and Strainer

A: REMOVAL

- 1) Set the vehicle on a lift.
- 2) Remove the front wheels.
- 3) Disconnect the ground cable from the battery.

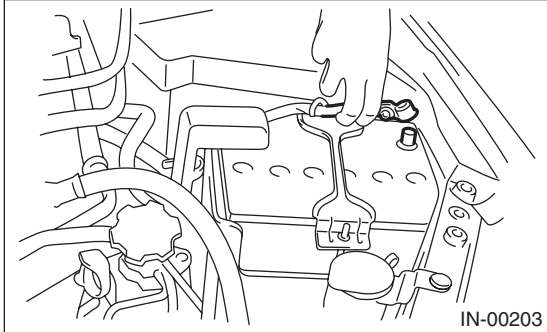

- 4) Remove the air intake duct.

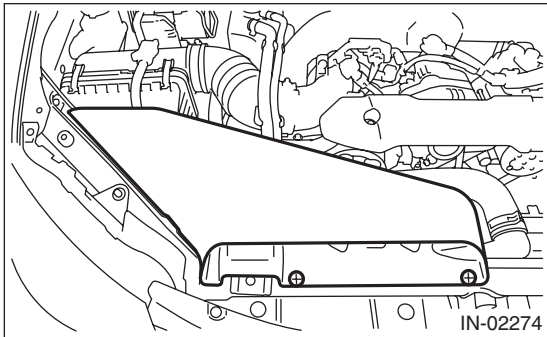

- 5) Remove the air intake boot.

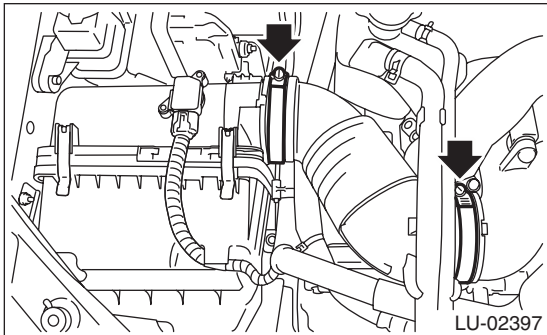

- 6) Remove the intercooler.
<Ref. to IN(H4DOTC)-11, REMOVAL, Intercooler.>
- 7) Remove the pitching stopper.

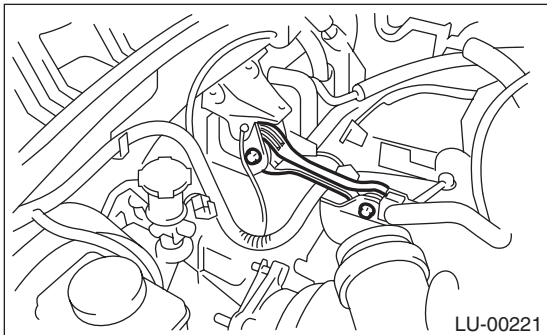

- 8) Remove the radiator upper brackets.

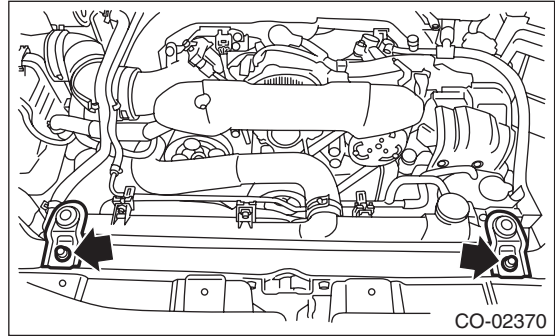

- 9) Support the engine with a lifting device and wire ropes.

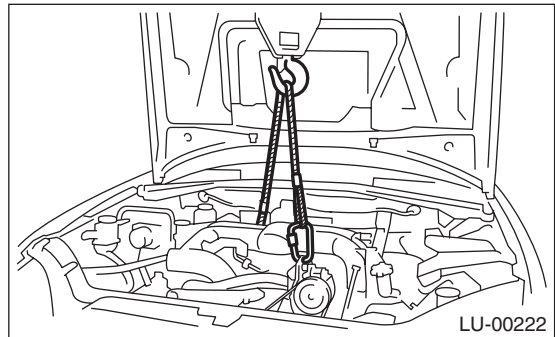

- 10) Lift up the vehicle.

CAUTION:

When lifting up the vehicle, raise up wire ropes at the same time.

- 11) Remove the under cover.
- 12) Drain the engine oil. <Ref. to LU(H4DOTC)-8, REPLACEMENT, Engine Oil.>
- 13) Remove the front exhaust pipe.
<Ref. to EX(H4DOTC)-6, REMOVAL, Front Exhaust Pipe.>
- 14) Remove the nuts which install engine mount onto front crossmember.

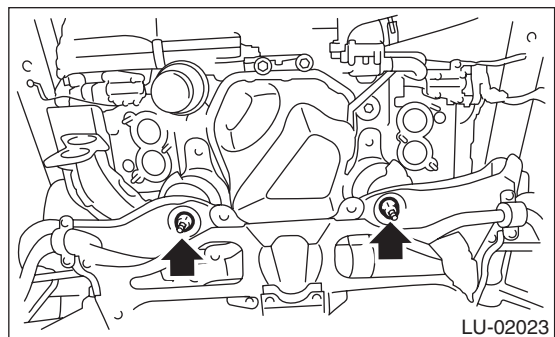

- 15) Remove the bolts which install oil pan on cylinder block with the engine raised up.
- 16) Insert an oil pan cutter blade between cylinder block-to-oil pan clearance and remove the oil pan.

CAUTION:

Do not use a screwdriver or similar tool in place of oil pan cutter.

- 17) Remove the oil strainer.

18) Remove the baffle plate.

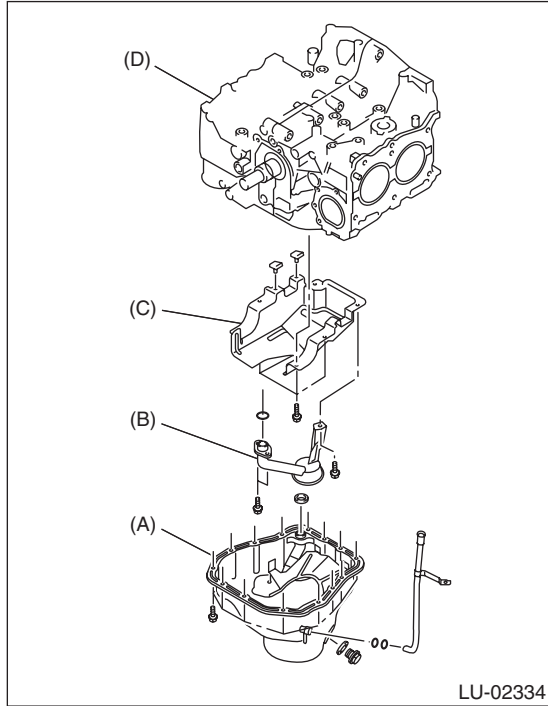

- (A) Oil pan
- (B) Oil strainer
- (C) Baffle plate
- (D) Cylinder block

B: INSTALLATION

NOTE:

Before installing the oil pan, clean the mating surface of oil pan and engine block.

1) Make sure that the seals (A) are installed securely on the baffle plate in a direction as shown in the figure below.

NOTE:

Use new seals.

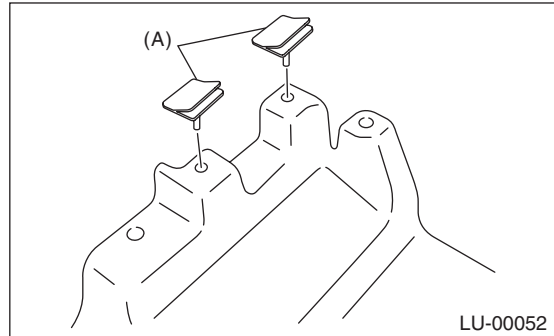

2) Install the baffle plate.

Tightening torque:

6.4 N·m (0.65 kgf-m, 4.7 ft-lb)

3) Install the oil strainer to the cylinder block.

NOTE:

Use new O-rings.

Tightening torque:

10 N·m (1.0 kgf-m, 7.2 ft-lb)

4) Tighten the oil strainer stay together with the baffle plate.

Tightening torque:

6.4 N·m (0.65 kgf-m, 4.7 ft-lb)

5) Apply liquid gasket to the mating surfaces of the oil pan, and install the oil pan.

NOTE:

- Use a new gasket.
- Install within 5 min. after applying liquid gasket.

Liquid gasket:

**THREE BOND 1217G (Part No. K0877Y0100)
 or equivalent**

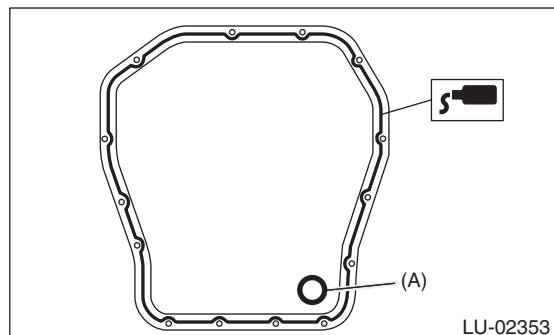

- (A) Gasket

Oil Pan and Strainer

Brought to you by Eris Studios
NOT FOR RESALE

LUBRICATION

6) Tighten the bolts which install oil pan to cylinder block.

Tightening torque:

T1: 5 N·m (0.5 kgf-m, 3.7 ft-lb)

T2: 6.4 N·m (0.65 kgf-m, 4.7 ft-lb)

T3: 10 N·m (1.0 kgf-m, 7.2 ft-lb)

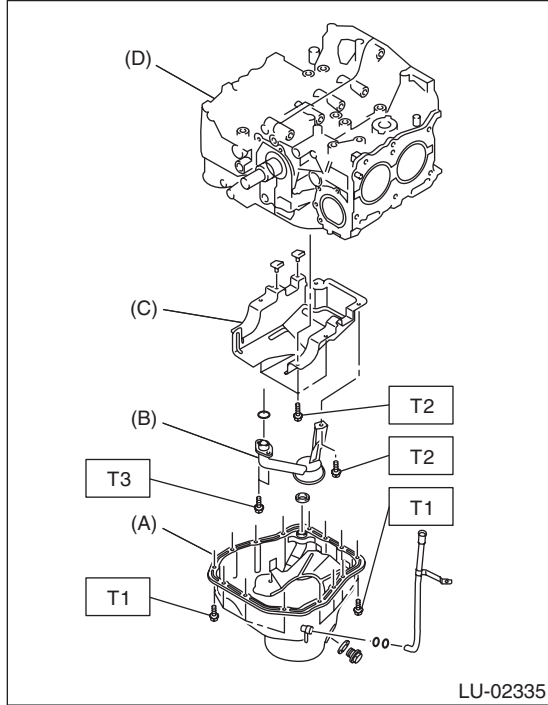

- (A) Oil pan
- (B) Oil strainer
- (C) Baffle plate
- (D) Cylinder block

7) Lower the engine onto front crossmember.

8) Tighten the nuts which install engine mount onto front crossmember.

Tightening torque:

85 N·m (8.7 kgf-m, 62.7 ft-lb)

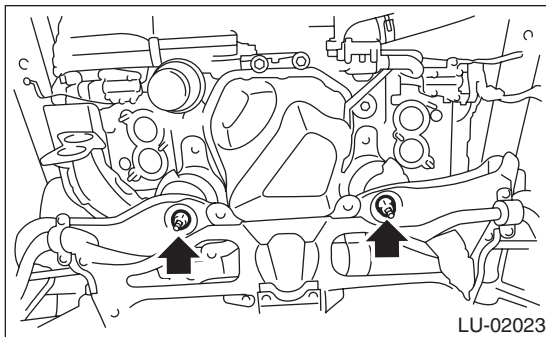

9) Install the front exhaust pipe. <Ref. to EX(H4DOTC)-7, INSTALLATION, Front Exhaust Pipe.>

10) Install the under cover.

11) Lower the vehicle.

CAUTION:

When lowering the vehicle, lower the lift up device and wire ropes at the same time.

12) Remove the lifting device and wire ropes.

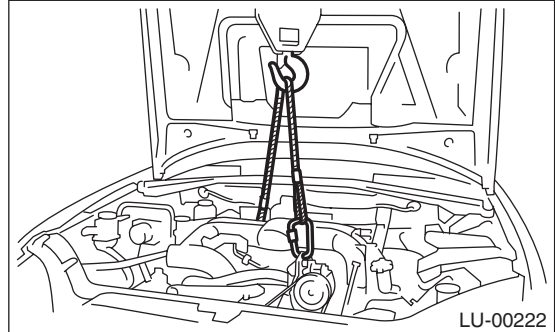

13) Install the pitching stopper.

Tightening torque:

T1: 50 N·m (5.1 kgf-m, 36.9 ft-lb)

T2: 58 N·m (5.9 kgf-m, 42.8 ft-lb)

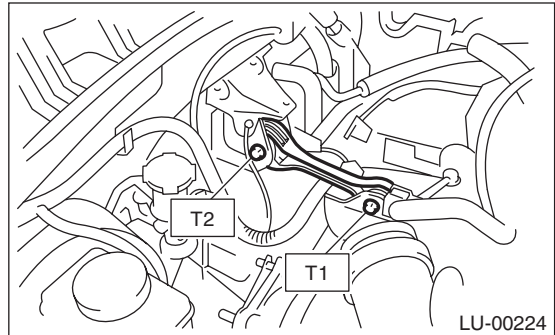

14) Install the radiator upper brackets.

Tightening torque:

12 N·m (1.2 kgf-m, 8.9 ft-lb)

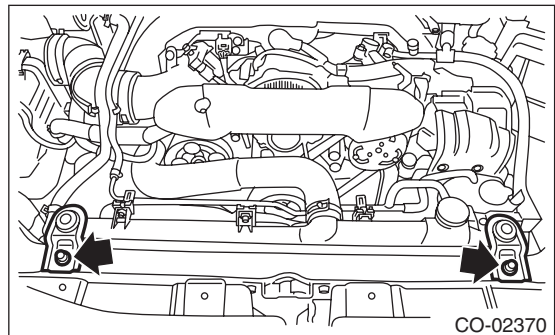

15) Install the intercooler. <Ref. to IN(H4DOTC)-12, INSTALLATION, Intercooler.>

16) Install the air intake boot.

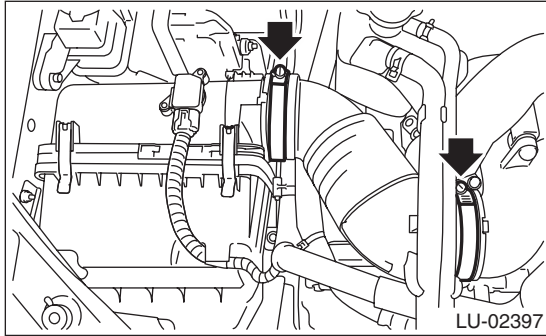

17) Install the air intake duct.

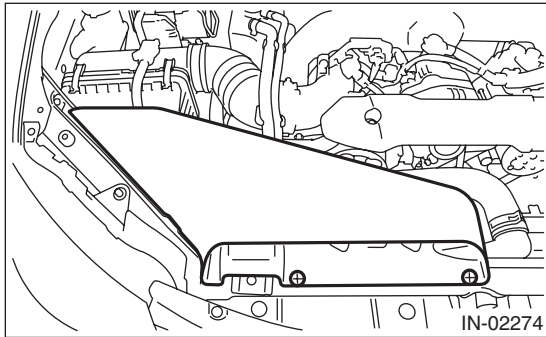

18) Install the front wheels.

Tightening torque:

100 N·m (10.2 kgf·m, 73.8 ft·lb)

19) Connect the ground cable to the battery.

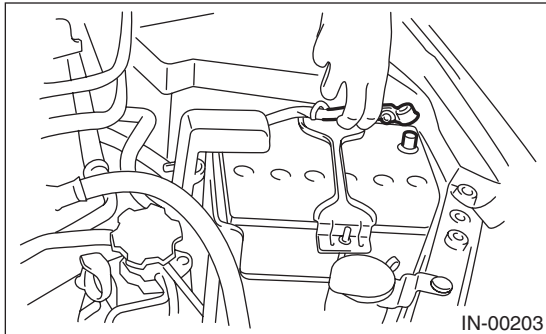

20) Refill the engine oil. <Ref. to LU(H4DOTC)-8, REPLACEMENT, Engine Oil.>

C: INSPECTION

Visually check that the oil pan, oil strainer, oil strainer stay and baffle plate are not damaged.

Oil Pressure Switch

LUBRICATION

Brought to you by Eris Studios
NOT FOR RESALE

6. Oil Pressure Switch

A: REMOVAL

- 1) Remove the generator from the bracket. <Ref. to SC(H4SO)-12, REMOVAL, Generator.>
- 2) Disconnect the terminal from oil pressure switch.

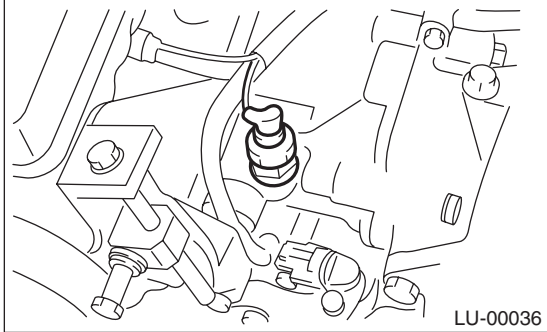

- 3) Remove the oil pressure switch.

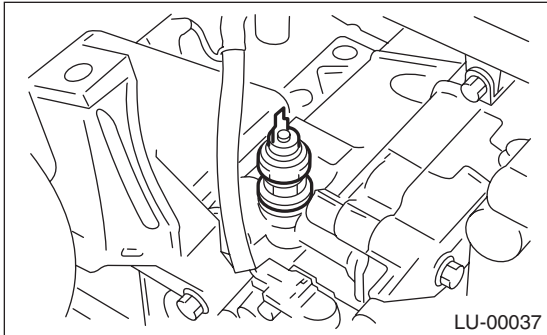

B: INSTALLATION

- 1) Apply liquid gasket to the oil pressure switch threads.

Liquid gasket:

THREE BOND 1324 (Part No. 004403007) or equivalent

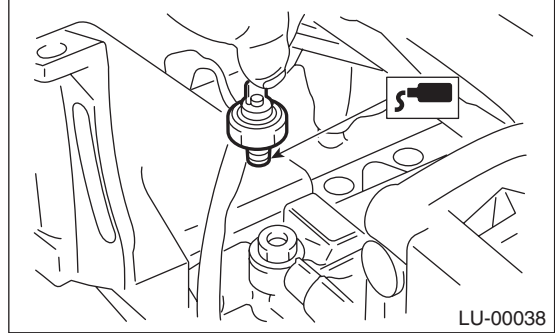

- 2) Install the oil pressure switch to the cylinder block.

Tightening torque:

25 N·m (2.5 kgf-m, 18.4 ft-lb)

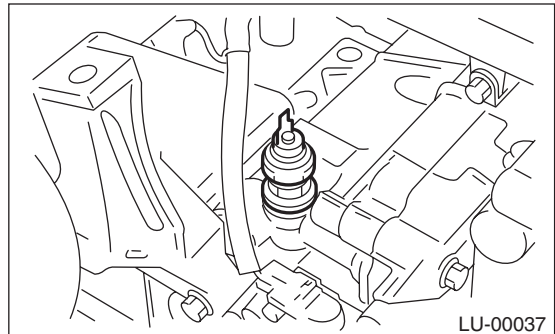

- 3) Connect the terminal to the oil pressure switch.

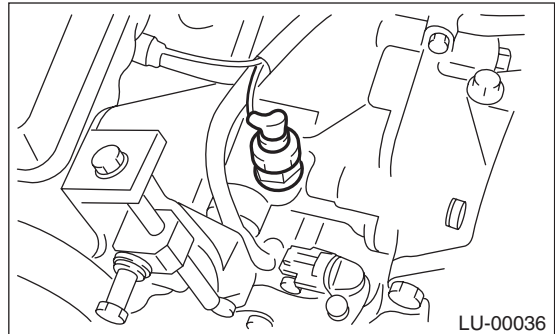

- 4) Install the generator to the bracket. <Ref. to SC(H4SO)-12, INSTALLATION, Generator.>

C: INSPECTION

Check the oil pressure switch installation portion for oil leakage and oil seepage.

7. Engine Oil Filter

A: REMOVAL

CAUTION:

If the engine oil is spilt over exhaust pipe or the under cover, wipe it off with cloth to avoid emitting smoke or causing a fire.

- 1) Set the vehicle on a lift.
- 2) Lift up the vehicle.
- 3) Remove the under cover.
- 4) Remove the oil filter (A) using the ST.

ST 18332AA000	OIL FILTER WRENCH (Outer diameter: 68 mm (2.68 in) for oil filter)
ST 18332AA010	OIL FILTER WRENCH (Outer diameter: 65 mm (2.56 in) for oil filter)

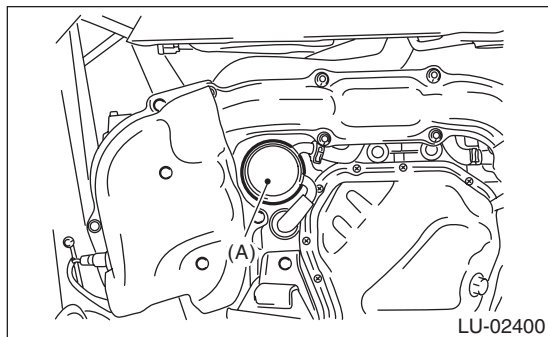

(A) Oil filter

B: INSTALLATION

CAUTION:

Do not tighten excessively, or oil may leak.

- 1) Clean the oil filter installing surface of cylinder block.
- 2) Obtain a new oil filter and apply a thin coat of engine oil to the seal rubber.
- 3) Install the oil filter turning it by hand, being careful not to damage the seal rubber.
 - Tighten the oil filter 65 mm (2.56 in) in diameter (approx. 2/3 — 3/4 rotation) after the seal rubber of the oil filter comes in contact with cylinder block or oil cooler. When using a torque wrench, tighten to 12 N·m (1.2 kgf-m, 8.7 ft-lb).
 - Tighten the oil filter 68 mm (2.68 in) in diameter (approx. 1 rotation) after the seal rubber of the oil filter comes in contact with cylinder block or oil cooler. When using a torque wrench, tighten to 14 N·m (1.4 kgf-m, 10.3 ft-lb).
- 4) Install the under cover.
- 5) Lower the vehicle.

C: INSPECTION

- 1) After installing the oil filter, run the engine and make sure that no oil is leaking around seal rubber.

NOTE:

The filter element and filter case are permanently jointed; therefore, interior cleaning is not necessary.

- 2) Check the engine oil level. <Ref. to LU(H4DOTC)-8, INSPECTION, Engine Oil.>

Engine Lubrication System Trouble in General

Brought to you by Eris Studios
NOT FOR RESALE

LUBRICATION

8. Engine Lubrication System Trouble in General

A: INSPECTION

Before performing diagnostics, make sure that the engine oil level is correct and no oil leakage exists.

Symptoms	Possible cause		Corrective action
1. Warning light remains ON.	1) Oil pressure switch failure	Cracked diaphragm or oil leakage within switch	Replace.
		Broken spring or seized contacts	Replace.
	2) Low oil pressure	Clogging of oil filter	Replace.
		Malfunction of oil by-pass valve in oil filter	Clean or replace.
		Malfunction of oil relief valve in oil pump	Clean or replace.
		Clogged oil passage	Clean.
		Excessive tip clearance and side clearance of oil pump rotor	Replace.
		Clogged oil strainer or broken pipe	Clean or replace.
	3) No oil pressure	Insufficient engine oil (degradation, etc.)	Replace.
		Broken pipe of oil strainer	Replace.
Stuck oil pump rotor		Replace.	
2. Warning light does not turn on.	1) Malfunction of combination meter		Replace.
	2) Poor contact of switch contact points		Replace.
	3) Disconnection of wiring		Repair.
3. Warning light flickers momentarily.	1) Poor contact of terminals		Repair.
	2) Defective wiring harness		Repair.
	3) Low oil pressure		Check for the same possible causes as listed 1) — 2).