

Brought to you by Eris Studios
NOT FOR RESALE

STARTING/CHARGING SYSTEMS

General Description

SPEED CONTROL SYSTEMS

Brought to you by Eris Studios
NOT FOR RESALE

1. General Description

A: SPECIFICATION

Accelerator pedal	Stroke	At pedal pad	50 — 59 mm (1.97 — 2.32 in)
-------------------	--------	--------------	-----------------------------

B: COMPONENT

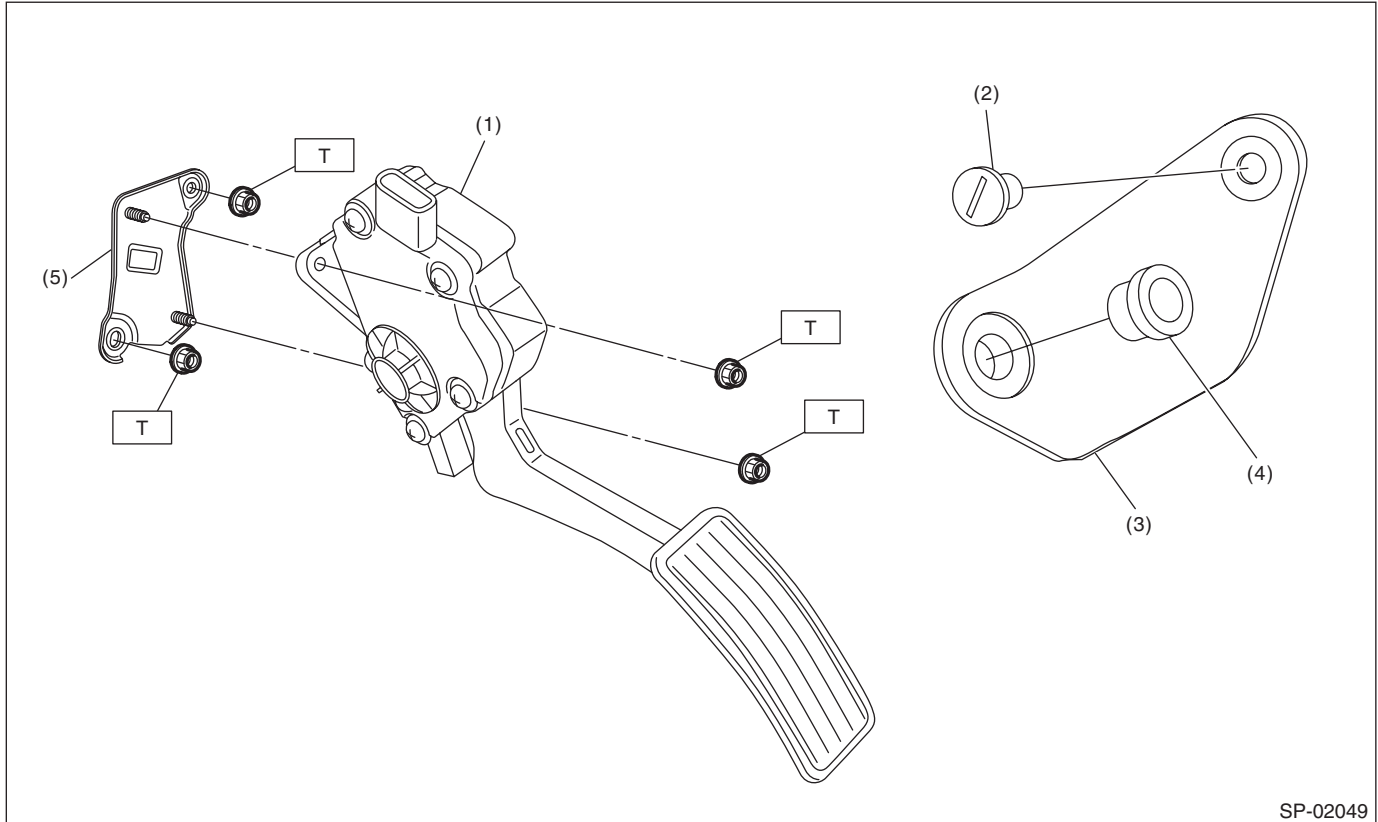

- | | |
|----------------------------|-------------------------------|
| (1) Accelerator pedal ASSY | (4) Accelerator stopper |
| (2) Clip | (5) Accelerator pedal bracket |
| (3) Accelerator plate | |

Tightening torque: N·m (kgf·m, ft·lb)
T: 18 (1.8, 13.3)

C: CAUTION

- Wear appropriate work clothing, including a cap, protective goggles and protective shoes when performing any work.
- Remove contamination including dirt and corrosion before removal or installation.
- Keep the parts in order and protect them from dust and dirt.
- Before removal or installation, be sure to clarify the failure. Avoid unnecessary removal, installation, disassembly and replacement.
- Vehicle components are extremely hot after driving. Be wary of receiving burns from heated parts.
- Be sure to tighten fasteners including bolts and nuts to the specified torque.
- Place shop jacks or rigid racks at the specified points.
- Before disconnecting connectors of sensors or units, be sure to disconnect the ground cable from the battery.

2. Accelerator Pedal

A: REMOVAL

- 1) Disconnect the ground cable from battery.

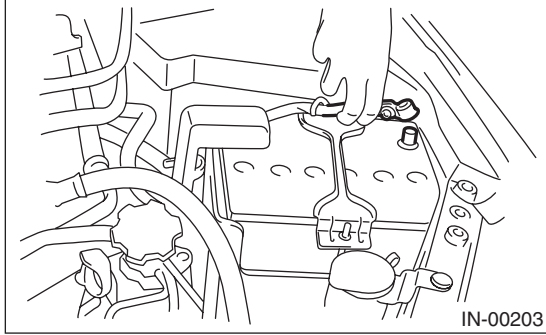

- 2) Disconnect the connector (A).
- 3) Remove the nut (B) securing accelerator pedal assembly.

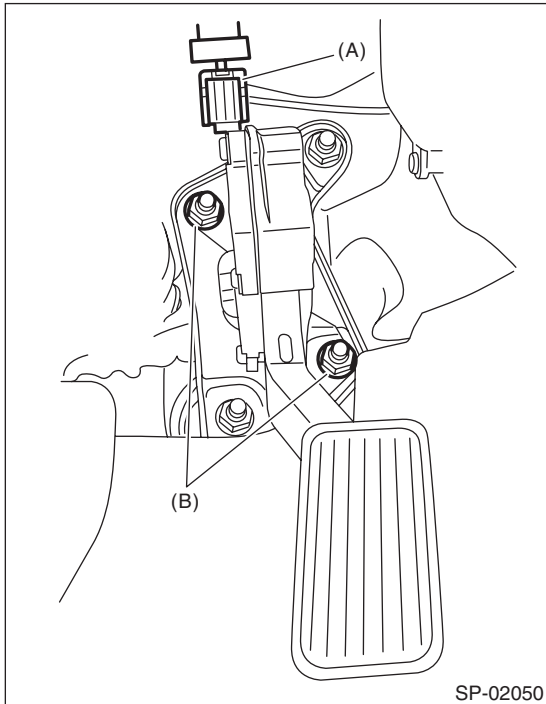

B: INSTALLATION

Install in the reverse order of removal.

Tightening torque:

18 N·m (1.8 kgf-m, 13.3 ft-lb)

C: DISASSEMBLY

NOTE:

The accelerator pedal cannot be disassembled.

Accelerator Pedal

SPEED CONTROL SYSTEMS

Brought to you by Eris Studios
NOT FOR RESALE

SP(H4SO)-4