

Brought to you by Eris Studios
NOT FOR RESALE

CONTROL SYSTEMS

5MT GEAR SHIFT LEVER

CONTROL SYSTEM

Brought to you by Eris Studios
NOT FOR RESALE

1. 5MT Gear Shift Lever

The manual transmission's gear shift lever system is a parallel link type whose stay is mounted through a cushion rubber.

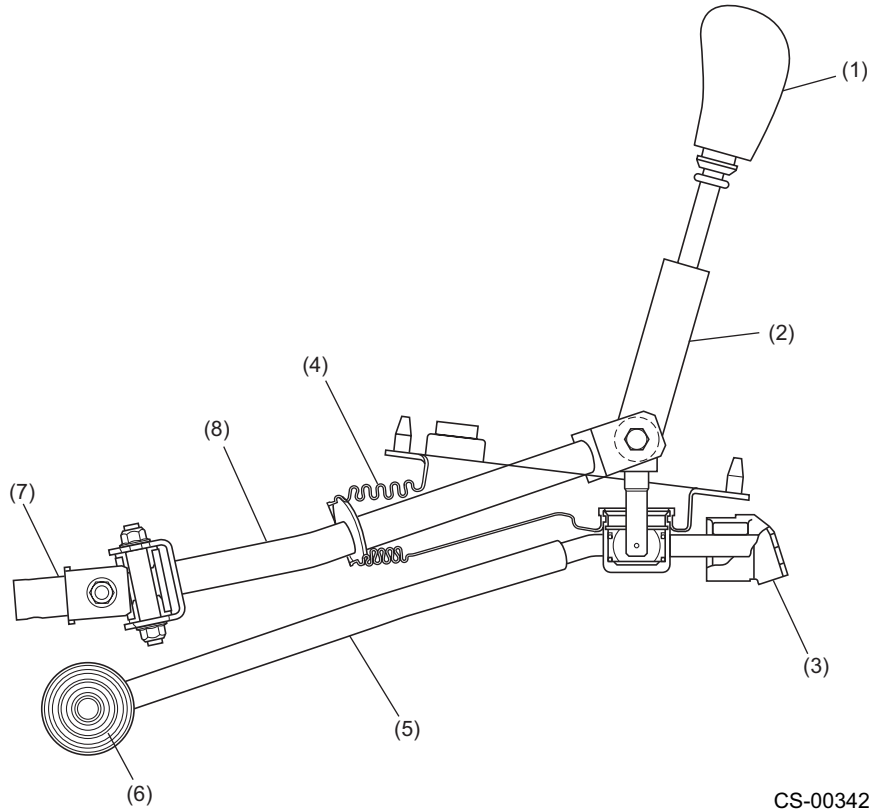

CS-00342

- | | |
|--------------------|---------------|
| (1) Knob | (5) Stay |
| (2) Lever | (6) Bushing B |
| (3) Cushion rubber | (7) Joint |
| (4) Boot | (8) Rod |