

Brought to you by Eris Studios  
NOT FOR RESALE

# **FUEL INJECTION (FUEL SYTEMS) H4SO**

### 1. General

- The Multipoint Fuel Injection (MFI) system supplies optimum air-fuel mixture under every engine operating condition through the use of the latest electronic control technology.

This system pressurizes the fuel to a constant pressure and injects it into each intake air port in the cylinder head. The injection quantity of fuel is controlled by an intermittent injection system where an electro-magnetic injection valve or injector opens for a short period that is precisely controlled depending on the quantity of air appropriate for each condition of operation. In actual control, an optimum fuel injection quantity is achieved by varying the duration of an electric pulse applied to the injector. This way of control enables simple, yet highly precise metering of the fuel.

- The engine control module (ECM) that controls the fuel injection system corrects the fuel injection amount depending on the vehicle speed, throttle opening, coolant temperature and other vehicle-operation-related information. The ECM receives the information in the form of electric signals from the corresponding sensors and switches.

The MFI system also has the following features:

- Reduced exhaust emissions
- Improves fuel efficiency
- Increased engine output
- Quick response to accelerator and brake pedal operation
- Superior start ability and warm-up performance in cold weather due to corrective controls made according to coolant and intake air temperatures

Brought to you by *www.4matstudios.com*  
 NOT FOR SALE

## 2. Air Line

### A: GENERAL

The air filtered by the air cleaner enters the throttle body where it is regulated in the volume by the throttle valve and then enters the intake manifold. It is then distributed to each cylinder where the air is mixed with fuel injected by the injector.

### B: MANIFOLD ABSOLUTE PRESSURE SENSOR

The manifold absolute pressure sensor is attached to the top of the throttle body, and continuously sends to the engine control module (ECM) voltage signals that are proportional to intake manifold absolute pressures. The ECM controls the fuel injection and ignition timing based on the intake manifold absolute pressure signals in addition to other signals from many sensors and other control modules.

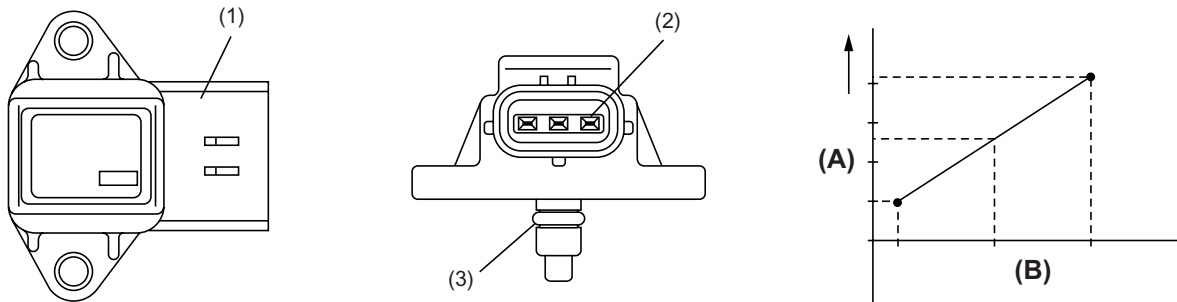

- (1) Connector
- (2) Terminal
- (3) O-ring

- (A) Output voltage
- (B) Absolute pressure

FU-02010

### C: ELECTRONIC CONTROL THROTTLE SYSTEM

- The electronic control throttle system consists of an accelerator pedal position sensor mounted on the accelerator pedal, a throttle position sensor and a throttle motor mounted on the throttle body, and the ECM, which controls these devices.
- The movement of the accelerator pedal is converted into electrical signals by the accelerator pedal position sensor and sent to the ECM. Based on these signals the ECM controls the throttle motor to open and close the throttle valve.
- Idling control is now performed by the electronic control throttle system in place of the idle air control solenoid valve.

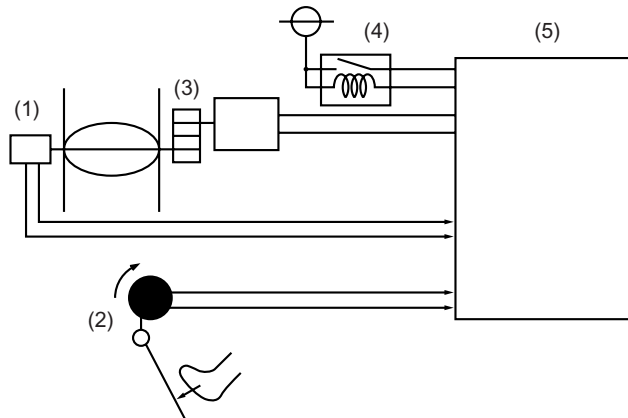

FU-01230

- |  |                                       |
|--|---------------------------------------|
| (1) Throttle position sensor             | (4) Electronic control throttle relay |
| (2) Accelerator pedal position sensor    | (5) ECM                               |
| (3) Electronic control throttle assembly |                                       |

Brought to you by *www.4studios.com*  
 NOT FOR SALE

## D: MASS AIR FLOW AND INTAKE AIR TEMPERATURE SENSOR

**NOTE:**

Not installed on some models.

The mass air flow and the intake air temperature sensors are integrated into a single unit. The unit is mounted on the air cleaner case and measures the amount as well as the temperature of the intake air.

The measured amount and temperature are converted into electrical signals and sent to the ECM. The ECM uses these signals to control injection and ignition timing as well as the fuel injection amount.

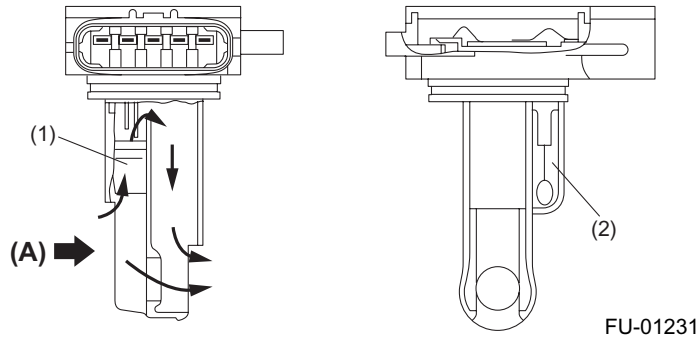

- (1) Mass air flow sensor
- (2) Intake air temperature sensor

(A) Air

# AIR LINE

## FUEL INJECTION (FUEL SYSTEM)

Brought to you by Eris Studios  
NOT FOR RESALE

### E: TUMBLE GENERATOR VALVE

#### NOTE:

This is not installed on some models.

- A tumble generator valve is provided on the intake manifold of each engine bank. The right bank tumble generator valve has butterfly valves for the #1 and #3 cylinders and the left bank tumble generator valve has those for the #2 and #4 cylinders. The two butterfly valves in each tumble generator valve are fitted on a single shaft that is driven by an actuator.

- The tumble generator valves are controlled by the ECM according to the coolant temperature and the time elapsed after start of the engine. When the engine is started, the butterfly valves are moved to the closing ends. In this state, the intake air flows at very high speeds passing through narrowed passages in the directions determined by the individual intake air ports in the cylinder head. This creates tumbling air motions in the cylinders, which enables lean mixtures to be ignited and thus harmful exhaust emissions to be reduced during engine start. The tumble generator valves are fully open when the engine is operating at an ordinary driving speed, allowing intake air to flow without being changed in direction and velocity.

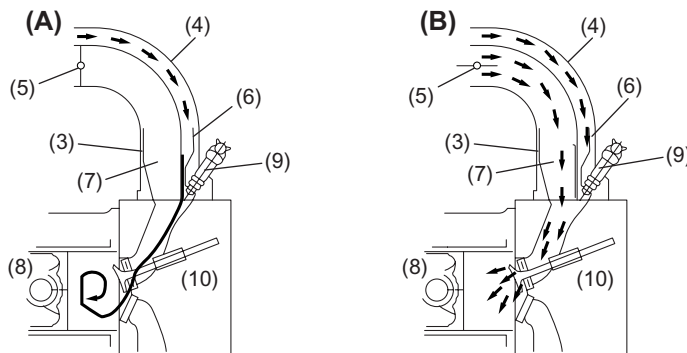
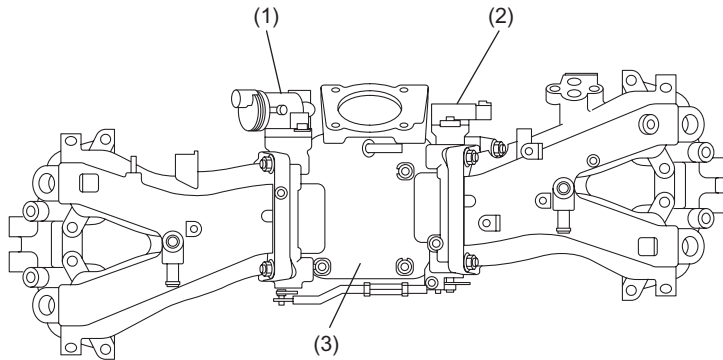

FU-01316

**(A)** Activated

**(B)** Not activated

(1) Actuator

(2) Tumble generator valve position sensor

(3) Tumble generator housing

(4) Intake manifold

(5) Tumble generator valve

(6) Tumble generating air passage

(7) Main intake air passage

(8) Piston

(9) Injector

(10) Cylinder head

**FU(H4SO)-6**

Brought to you by *Hyundai*  
NOT FOR SALE

### 3. Fuel System

#### A: GENERAL

- The fuel pressurized by the fuel tank inside pump is delivered to each fuel injector through the fuel filter. Fuel injection pressure is regulated to an optimum level by the pressure regulator.
- Each injector injects fuel into the intake port of the corresponding cylinder where the fuel is mixed with air. The mixture then enters the cylinder. Fuel injection amount and timing are regulated by the ECM.

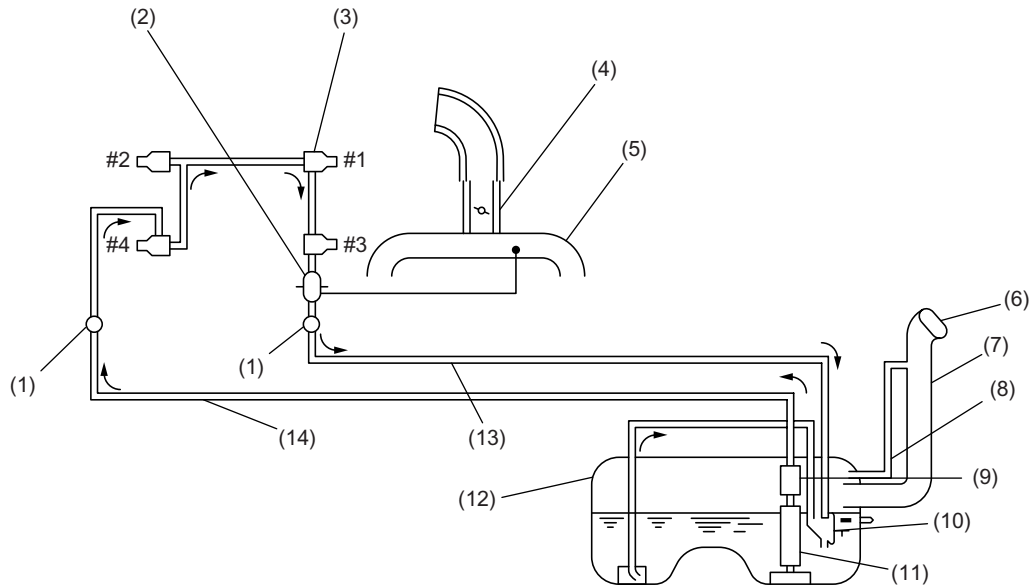

FU-02409

- |                        |                         |
|------------------------|-------------------------|
| (1) Fuel damper valve  | (8) Air vent pipe       |
| (2) Pressure regulator | (9) Fuel filter         |
| (3) Fuel injector      | (10) Jet pump           |
| (4) Throttle body      | (11) Fuel pump          |
| (5) Intake manifold    | (12) Fuel tank          |
| (6) Filler cap         | (13) Fuel return line   |
| (7) Filler pipe        | (14) Fuel delivery line |

# FUEL SYSTEM

## FUEL INJECTION (FUEL SYSTEM)

Brought to you by Eris Studios  
NOT FOR RESALE

### B: PRESSURE REGULATOR

The pressure regulator is installed at the injector end of the fuel supply line. It has a fuel chamber and spring chamber separated by a diaphragm. The fuel chamber is connected to the fuel supply line and the spring chamber is connected to the intake manifold. Fuel chamber also has a relief valve connected to the fuel return line through which fuel returns to the fuel tank. When the intake manifold vacuum increases, the diaphragm is pulled and the relief valve opens to decrease the fuel supply line pressure (or fuel injection pressure). When the intake manifold vacuum decreases, the diaphragm is pushed by the spring to increase the fuel supply line pressure. Thus, the difference between the fuel injection pressure and the intake manifold vacuum is kept at a constant level to precisely control the amount of injected fuel.

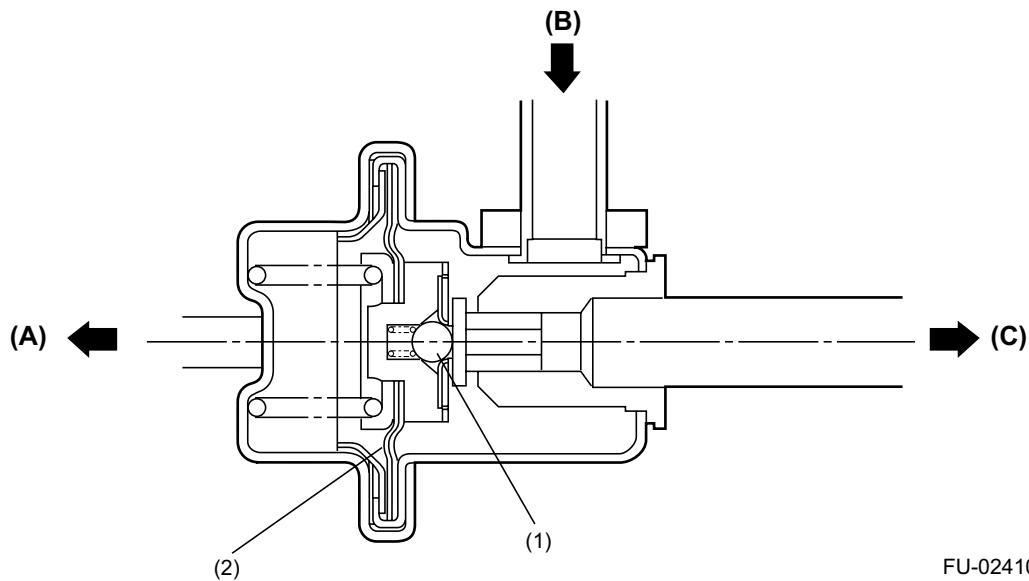

FU-02410

- (1) Relief valve
- (2) Diaphragm

- (A) To intake manifold
- (B) Fuel IN
- (C) Fuel OUT



Brought to you by *www.EngineeringBooksPdf.com*  
NOT FOR SALE

### C: FUEL INJECTOR

- The MFI system employs top feed type fuel injectors.
- Each injector is installed in the fuel pipe in such a way that the injector is cooled by fuel.
- The features of this type of fuel injector are as follows:
  - 1) High heat resistance
  - 2) Low driving noise
  - 3) Easy to service
  - 4) Small size
- The injector injects fuel according to the valve open signal from the ECM. The needle valve is lifted by the solenoid, which is energized on arrival of the valve open signal.
- Since the injector's nozzle hole area, the lift of valve and the fuel pressure are kept constant, the amount of fuel injected is controlled only by varying the duration of the valve open signal from the ECM.
- The multi-hole nozzle makes it possible for the injector to produce fine fuel particles, which enhances the combustion efficiency and output performance of the engine.

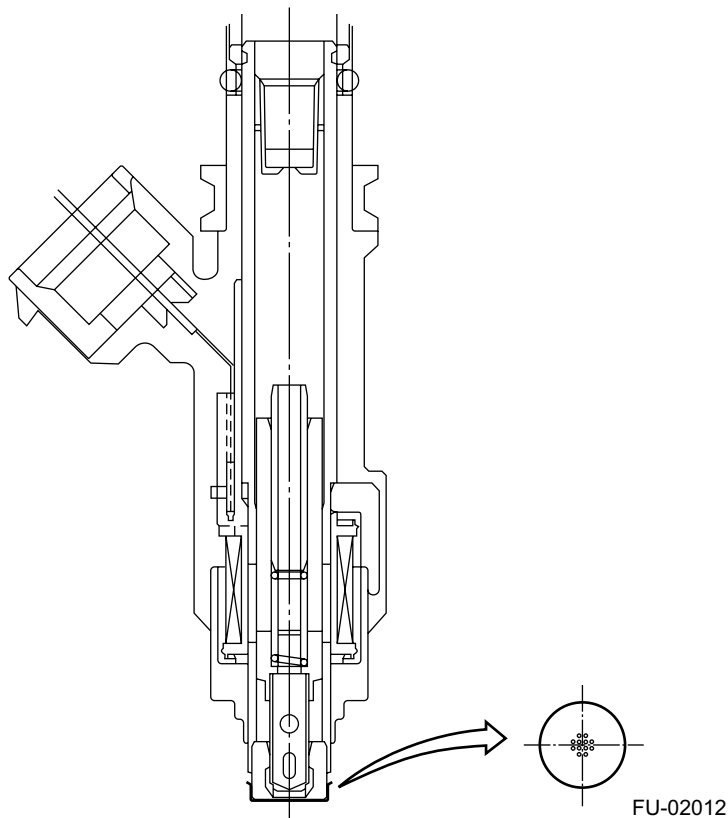

# FUEL SYSTEM

## FUEL INJECTION (FUEL SYSTEM)

Brought to you by Eris Studios  
NOT FOR RESALE

### D: FUEL TANK

The fuel tank utilizes a two-compartment design to ensure sufficient capacity without interfering with the rear differential. It is provided with a suction jet pump (included in the fuel pump and fuel level sensor assembly) which transfers fuel from one compartment to the other.

Each compartment has an individual fuel level sensor. The fuel tank is located under the rear seat and secured with hold-down bands.

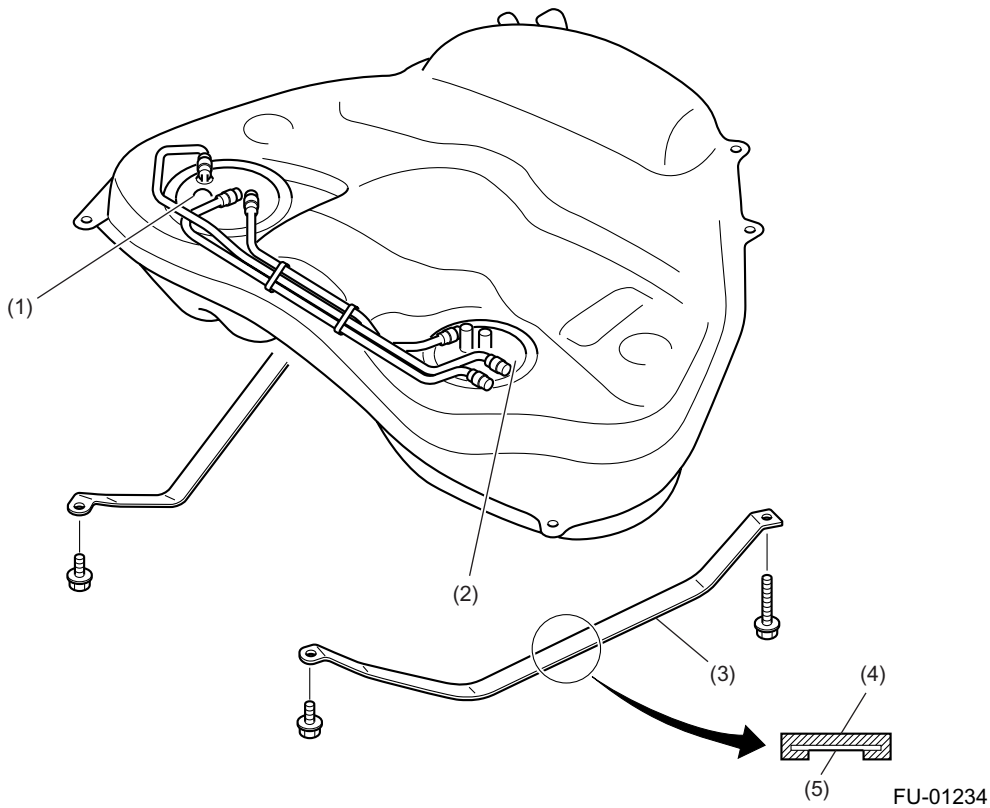

- (1) Fuel pump and fuel level sensor assembly
- (2) Fuel sub level sensor
- (3) Band

- (4) Cushion
- (5) Steel

## E: FUEL PUMP AND FUEL LEVEL SENSOR ASSEMBLY

### 1. FUEL PUMP

The fuel pump consists of a motor, impeller, pump casing, pump cover, check valve and filter. It is located in the fuel tank and combined with the fuel level sensor into a single unit. The operation of this impeller type pump is very quiet.

- When the ignition switch is turned ON, fuel pump relay is activated. Then the motor operates to rotate the impeller.
- As the impeller rotates, fuel in a vane groove of the impeller flows along the fuel passage into the next vane groove by centrifugal force. When fuel flows from one groove to the next, a pressure difference occurs due to friction. This creates a pumping effect.
- The fuel pushed up by rotation of the impeller then passes through the clearance between the armature and the magnet of the motor and is discharged through the check valve.
- When the fuel discharge pressure reaches the specified level, the relief valve opens and excess fuel is released into the fuel tank. In this manner, the relief valve prevents an abnormal increase in fuel pressure.
- When the engine and the fuel pump stop, check valve operates to close the discharge port, so that the fuel pressure in the fuel delivery line is retained.

### 2. FUEL LEVEL SENSOR

The fuel level sensor is integrated with the fuel pump, which is located in the fuel tank. The sensor outputs an electric resistance signal that varies with movement of its float to indicate the level of the fuel remaining in the tank.

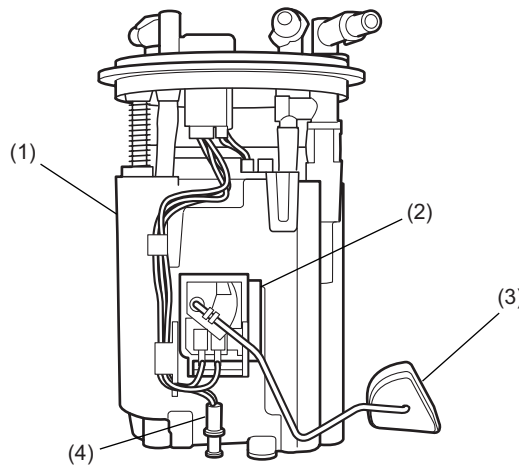

FU-02519

- (1) Fuel pump assembly
- (2) Fuel level sensor
- (3) Float
- (4) Fuel temperature sensor

# FUEL SYSTEM

## FUEL INJECTION (FUEL SYSTEM)

Brought to you by Eris Studios  
NOT FOR RESALE

### 3. JET PUMP

- The jet pump utilizes the velocity of fuel returning from the engine to produce vacuum in it.
- Using the pumping effect produced by the vacuum, the jet pump transfers fuel from the sub-compartment and main compartment of the fuel tank to the fuel pump.
- When the return line nozzle is clogged, the fuel sent back through the return line flows back into the fuel tank via the relief valve.

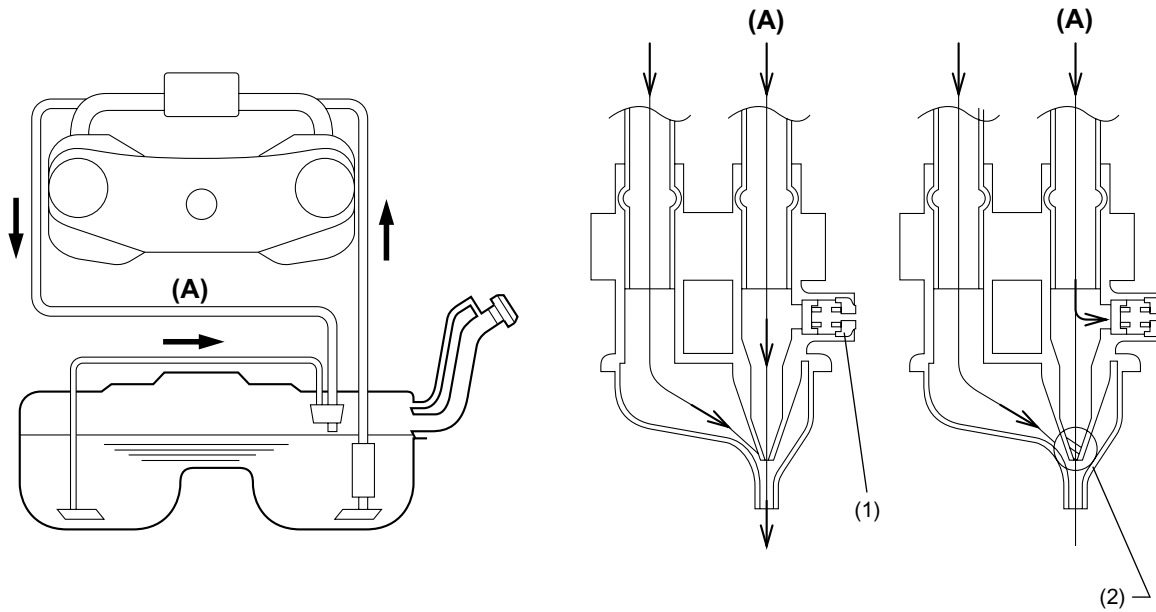

FU-00226

- (1) Relief valve
- (2) Nozzle

(A) Return line

### 4. FUEL FILTER

The fuel filter is integrated with the fuel pump assembly, which is located in the fuel tank.

Brought to you by *Hydros Studios*  
NOT FOR SALE

### F: SUB-COMPARTMENT FUEL LEVEL SENSOR

This sensor detects the level of the fuel in the sub side (the side without a fuel pump) of the fuel tank. Also, when the jet pump is operating, fuel in the sub side is drawn up and transferred to the fuel pump.

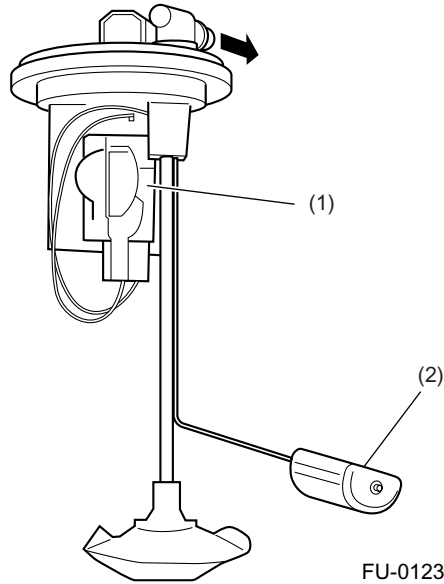

- (1) Fuel level sensor
- (2) Float

(A) To jet pump

### 4. Sensors and Switches

#### A: FRONT OXYGEN (A/F) SENSOR

- The front oxygen sensor uses zirconium oxide ( $ZrO_2$ ), which is a solid electrolyte, at portions exposed to exhaust gas.
  - The zirconium oxide has the property of generating electromotive force when its both sides are exposed to oxygen ions of different concentration and the magnitude of this electromotive force depends on how much the difference is.
- The front oxygen (A/F) sensor detects the amount of oxygen in exhaust gases by making use of this property of the zirconium oxide material.
- The sensor incorporates a ceramic heater to improve its performance at low temperatures.

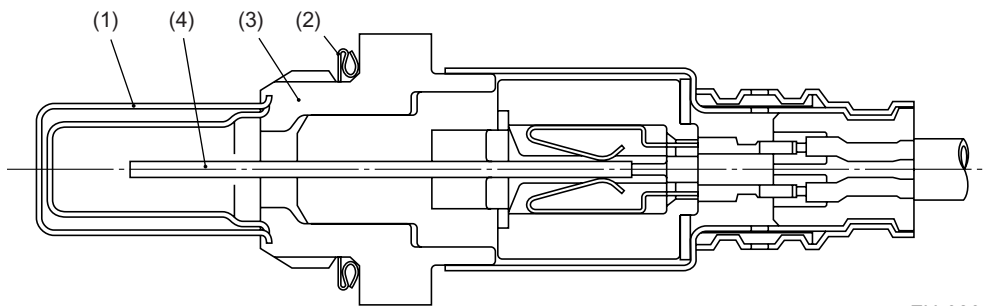

FU-02014

- (1) Protection tube
- (2) Gasket
- (3) Sensor housing
- (4) Ceramic heater

# SENSORS AND SWITCHES

Brought to you by *www.EngineeringBooksPdf.com*  
NOT FOR SALE

- When rich air-fuel mixture is burnt in the cylinder, the oxygen in the exhaust gases is almost completely used in the catalytic reaction by the platinum coating on the external surface of the zirconium tube. This results in a very large difference in the oxygen ion concentration between the inside and outside of the tube, and the electromotive force generated is large.
- When a lean air-fuel mixture is burnt in the cylinder, relatively large amount of oxygen remains in the exhaust gases even after the catalytic action, and this results in a small difference in the oxygen ion concentration between the tube's internal and external surfaces. The electromotive force in this case is very small.
- The difference in oxygen concentration changes drastically in the vicinity of the stoichiometric air-fuel ratio, and hence the change in the electromotive force is also large. By using this information, the ECM can determine the air-fuel ratio of the supplied mixture easily. The front oxygen (A/F) sensor does not generate much electromotive force when the temperature is low. The output characteristics of the sensor stabilize at a temperature of approximately 700°C (1,292°F).

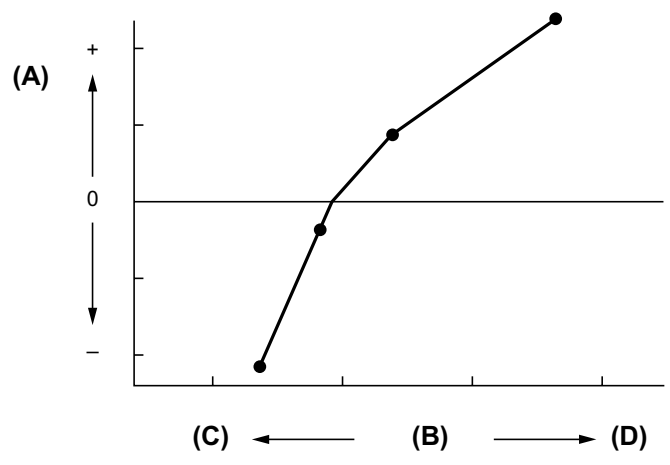

FU-02015

- (A) Current
- (B) Air/fuel ratio
- (C) Rich
- (D) Lean

# SENSORS AND SWITCHES

## FUEL INJECTION (FUEL SYSTEM)

Brought to you by Eris Studios  
NOT FOR RESALE

### B: FRONT OXYGEN SENSOR AND REAR OXYGEN SENSOR

#### NOTE:

The front oxygen sensor is not installed on some models.

- The front oxygen sensor and rear oxygen sensor are used to sense oxygen concentration in the exhaust gas. If the air-fuel ratio is leaner than the stoichiometric ratio in the mixture (i.e., excessive amount of air), the exhaust gas contains more oxygen. To the contrary, if the fuel ratio is richer than the stoichiometric ratio, the exhaust gas contains almost no oxygen.
- Detecting the oxygen concentration in exhaust gas using the front oxygen sensor and rear oxygen sensor makes it possible to determine whether the air-fuel ratio is leaner or richer than the stoichiometric ratio.
- The front oxygen sensor and the rear oxygen sensor have a zirconium tube (ceramic), which generates voltage if there is a difference in oxygen ion concentration between the inside and outside of the tube. Platinum is coated on the inside and outside of the zirconium tube as a catalysis and electrode material. The sensor housing is grounded to the exhaust pipe and the inside is connected to the ECM through the harness.
- A ceramic heater is employed to improve performance at low temperatures.

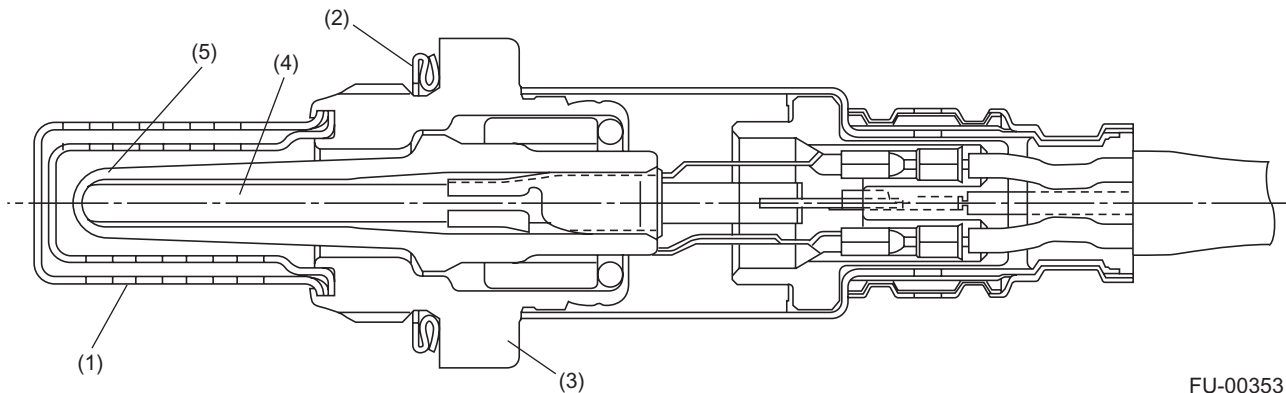

FU-00353

- |                     |                    |
|---------------------|--------------------|
| (1) Protection tube | (4) Ceramic heater |
| (2) Gasket          | (5) Zirconium tube |
| (3) Sensor housing  |                    |



Brought to you by *www.EngineeringBooksPdf.com*  
 NOT FOR SALE

- When rich air-fuel mixture is burnt in the cylinder, the oxygen in the exhaust gases is almost completely used in the catalytic reaction by the platinum coating on the external surface of the zirconium tube. This results in a very large difference in the oxygen ion concentration between the inside and outside of the tube, and the electromotive force generated is large.
- When a lean air-fuel mixture is burnt in the cylinder, relatively large amount of oxygen remains in the exhaust gases even after the catalytic action, and this results in a small difference in the oxygen ion concentration between the tube's internal and external surfaces. The electromotive force in this case is very small.
- The difference in oxygen concentration changes drastically in the vicinity of the stoichiometric air-fuel ratio, and hence the change in the electromotive force is also large. By using this information, the ECM can determine the air-fuel ratio of the supplied mixture easily. The rear oxygen sensor does not generate much electromotive force when the temperature is low. The output characteristics of the sensor stabilize at a temperature of approximately 300 to 400°C (572 to 752°F).

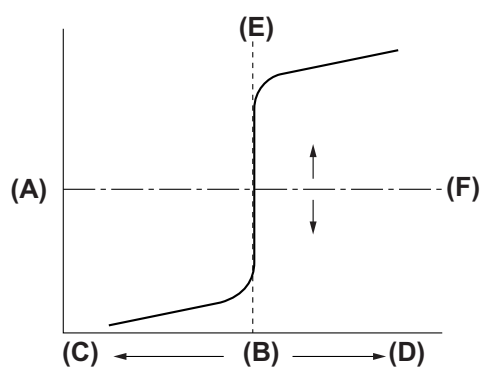

FU-02016

- (A) Electromotive force
- (B) Air/fuel ratio
- (C) Lean
- (D) Rich
- (E) Stoichiometric ratio
- (F) Comparison voltage

# SENSORS AND SWITCHES

## FUEL INJECTION (FUEL SYSTEM)

Brought to you by Eris Studios  
NOT FOR RESALE

### C: ENGINE COOLANT TEMPERATURE SENSOR

The engine coolant temperature sensor is located on the engine coolant pipe. The sensor uses a thermistor whose resistance changes inversely with temperature. Resistance signals as engine coolant temperature information are transmitted to the ECM to make fuel injection, ignition timing, purge control solenoid valve and other controls.

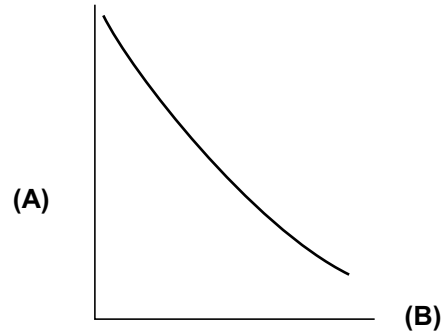
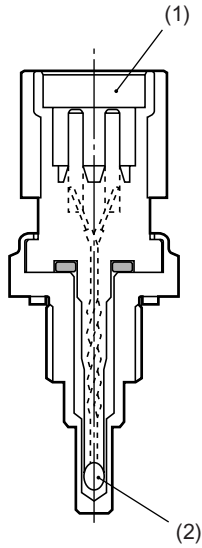

FU-02017

- (1) Connector
- (2) Thermistor element

- (A) Resistance ( $k\Omega$ )
- (B) Temperature  $^{\circ}C$  ( $^{\circ}F$ )

Brought to you by *www.technicalstudios.com*  
NOT FOR SALE

### D: CRANKSHAFT POSITION SENSOR

- The crankshaft position sensor is installed on the oil pump, which is located in the front center portion of the cylinder block. The sensor generates a pulse when one of the teeth on the perimeter of the crankshaft sprocket (rotating together with the crankshaft) passes in front of it. The ECM determines the crankshaft angular position by counting the number of pulses.
- The crankshaft position sensor is a molded type, which consists of a magnet, core, coil, terminals and other components as illustrated below.

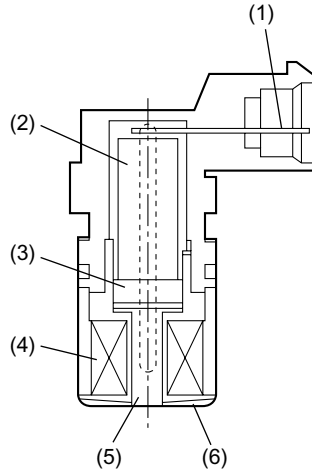

FU-00234

- (1) Terminal
- (2) Yoke core
- (3) Magnet

- (4) Coil
- (5) Core
- (6) Cover

# SENSORS AND SWITCHES

## FUEL INJECTION (FUEL SYSTEM)

Brought to you by Eris Studios  
NOT FOR RESALE

● As the crankshaft rotates, each tooth aligns with the crankshaft position sensor. At that time, the magnetic flux in the sensor's coil changes since the air gap between the sensor pickup and the sprocket changes. This change in magnetic flux induces a voltage pulse in the sensor and the pulse is transmitted to the ECM.

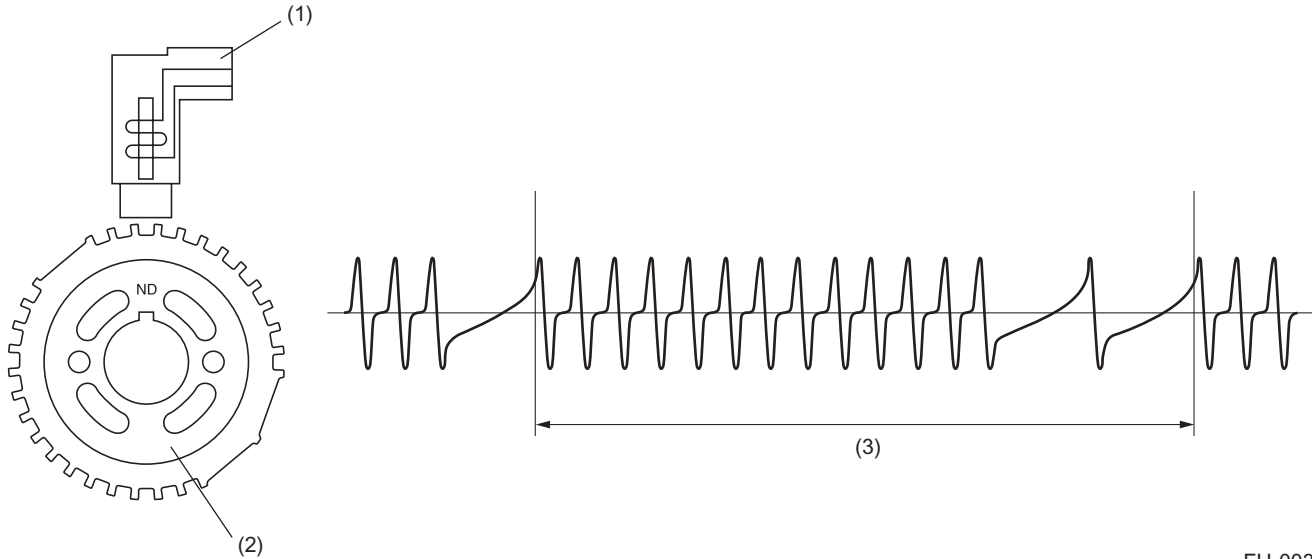

FU-00354

- (1) Crankshaft position sensor
- (2) Crankshaft sprocket
- (3) Crankshaft half rotation

Brought to you by *www.technicalstudios.com*  
NOT FOR SALE

### E: CAMSHAFT POSITION SENSOR

- The camshaft position sensor is located on the left-hand camshaft support. This sensor detects the combustion cylinder at any given moment.
  - The sensor generates a pulse when one of the bosses on the back of the left-hand camshaft drive sprocket passes in front of the sensor. The ECM determines the camshaft angular position by counting the number of pulses.
- Internal construction and the basic operating principle of the camshaft position sensor are similar to those of the crankshaft position sensor.

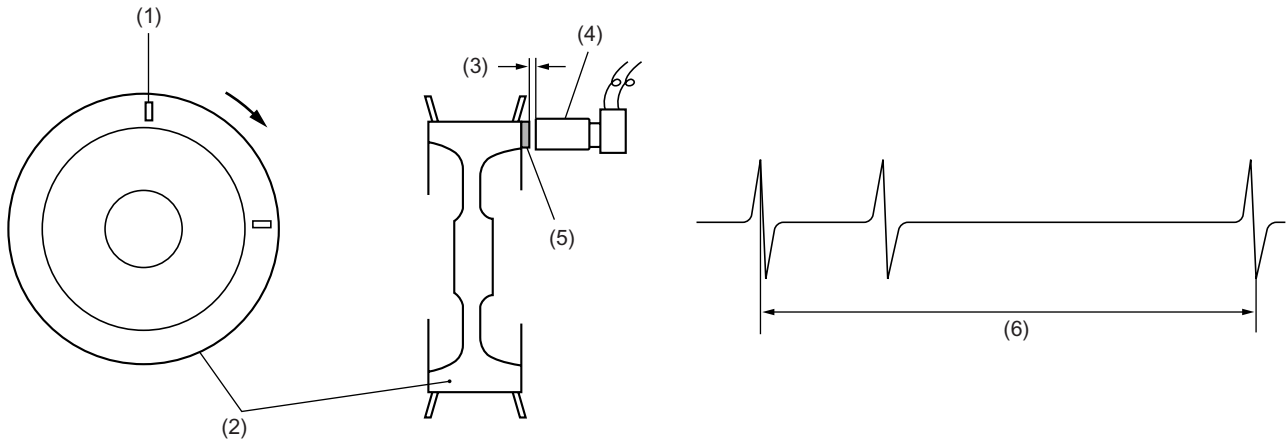

FU-02018

- (1) Boss
- (2) Cam sprocket
- (3) Air gap

- (4) Camshaft position sensor
- (5) Boss
- (6) Camshaft one rotation (crankshaft two rotations)

# SENSORS AND SWITCHES

## FUEL INJECTION (FUEL SYSTEM)

Brought to you by Eris Studios  
NOT FOR RESALE

### F: KNOCK SENSOR

- The knock sensor is installed on the cylinder block, and senses knocking that occur in the engine.
- The sensor is a piezo-electric type, which converts vibration resulting from knocking into electric signals.
- In addition to a piezo-electric element, the sensor has a weight and case as its components. If knocking occurs in the engine, the weight in the case moves causing the piezo-electric element to generate a voltage.
- The knock sensor harness is connected to the engine harness.

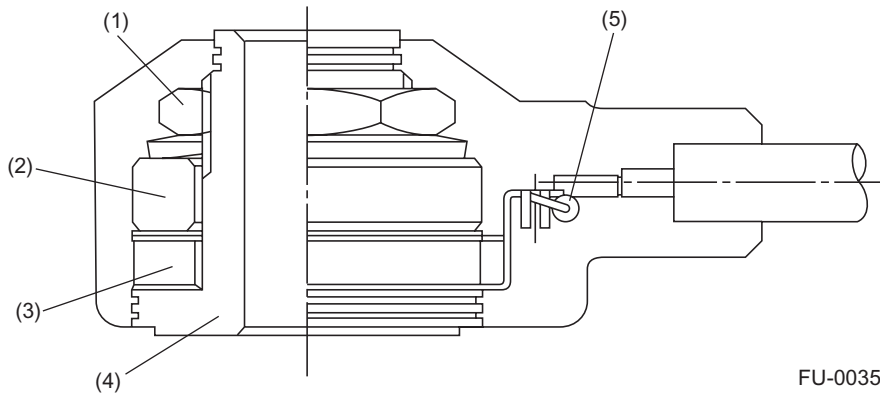

FU-00356

- (1) Nut
- (2) Weight
- (3) Piezo-electric element
- (4) Housing
- (5) Resistance

### G: VEHICLE SPEED SENSOR

Vehicle speed signals are sent from the vehicle speed sensor to the ABS and VDC control modules. The signals are sent to the ECM via CAN communication. (For details, refer to the LAN section.)  
<Ref. to LAN section.>

Brought to you by *www.technicalstudios.com*  
NOT FOR SALE

## 5. Control System

### A: GENERAL

The ECM receives signals from various sensors, switches, and other control modules. Using these signals, it determines the engine operating conditions and if necessary, emits signals to one or more systems to control them for optimum operation.

Major control items of the ECM are as follows:

- Fuel injection control
- Ignition control
- Idle air control
- Fuel pump control
- Canister purge control\*<sup>1</sup>
- Radiator fan control\*<sup>2</sup>
- On-board diagnosis function

\*1: Canister purge control is described under EC(H4SO) — Evaporative Emission Control System. <Ref. to EC(H4SO) section.>

\*2: Radiator fan control is described under CO(H4SO). <Ref. to CO(H4SO) section.>

# CONTROL SYSTEM

## FUEL INJECTION (FUEL SYSTEM)

Brought to you by Eris Studios  
NOT FOR RESALE

### B: INPUT AND OUTPUT SIGNALS

Signal	Unit	Function
Input signals	Manifold absolute pressure sensor	Detects the pressure of intake air (measures the absolute pressure).
	Mass air flow and intake air temperature sensor	Detects the temperature and amount of intake air.
	Throttle position sensor	Detects the throttle valve position.
	Front oxygen (A/F) sensor	Detects the density of oxygen in exhaust gases at the upstream of the front catalytic converter.
	Front oxygen sensor Rear oxygen sensor	Detects the density of oxygen in exhaust gases at the downstream of the front catalytic converter.
	Crankshaft position sensor	Detects the crankshaft angular position.
	Camshaft position sensor	Detects the combustion cylinder.
	Engine coolant temperature sensor	Detects the engine coolant temperature.
	Knock sensor	Detects engine knocking.
	Accelerator pedal position sensor	Indicates the accelerator pedal position.
	Ignition switch	Detects operation of the ignition switch.
	Starter switch	Detects the condition of engine cranking.
	Neutral position switch (MT)	Detects that the gear is in neutral.
	Inhibitor switch (AT)	Detects shift positions.
	A/C switch	Detects ON-OFF operation of the A/C switch.
	Fuel temperature sensor	Detects the temperature of the fuel in the fuel tank.
	Fuel level sensor	Detects the level of the fuel in the fuel tank.
	Fuel tank pressure sensor	Detects the evaporation gas pressure in the fuel tank.
	A/C mid pressure switch	Detects operation of the A/C mid pressure switch.
	Wiper switch	Detects ON-OFF operation of the wiper switch.
	Power steering switch	Detects operation of the power steering switch.
Small light switch	Detects ON-OFF operation of the small light switch.	
Blower fan switch	Detects ON-OFF operation of the blower fan switch.	
Rear defogger switch	Detects ON-OFF operation of the rear defogger switch.	



# CONTROL SYSTEM

## FUEL INJECTION (FUEL SYSTEM)

Brought to you by *Pro Studios*  
NOT FOR SALE

Signal	Unit	Function
Output signals	Fuel injector	Activates an injector.
	Ignition signal	Turns the primary current to the ignition coil ON or OFF.
	Electronic control throttle	Controls motor output for the electronic control throttle.
	Fuel pump relay	Turns ON or OFF the fuel pump relay.
	A/C control relay	Turns ON or OFF the A/C control relay.
	Radiator fan control relay	Turns ON or OFF the radiator fan control relay.
	Tumble generator valve actuator	Operates the tumble generator valve.
	Engine warning light	Indicates existence of abnormality.
	Purge control solenoid valve	Controls purge of evaporative gas absorbed by the canister.
	EGR valve	Adjusts the exhaust gas circulating flow to the intake pipe.
	Heater circuit of front and rear oxygen sensors	Controls heater of front and rear oxygen sensors.
	Pressure control solenoid valve	Controls evaporation pressure in the fuel tank.
	Drain valve	Closes the evaporation line between the fuel tank and canister to detect leakage of evaporation gas.
	Power supply	Controls ON/OFF of the main power supply relay.

### C: FUEL INJECTION CONTROL

- The ECM receives signals from various sensors and based on them, it determines the amount of fuel injected and the fuel injection timing. It performs the sequential fuel injection control over the entire engine operating range except during start-up of the engine.
- The amount of fuel injected depends upon the length of time the injector stays open. The fuel injection duration is determined according to varying operating condition of the engine. For the purpose of achieving highly responsive and accurate fuel injection duration control, the ECM performs a new feedback control that incorporates a learning feature as detailed later.
- The sequential fuel injection control is performed such that fuel is injected accurately at the time when the maximum air intake efficiency can be achieved for each cylinder (i.e., fuel injection is completed just before the intake valve begins to open).

#### 1. FUEL INJECTION DURATION

Fuel injection duration is basically determined as indicated below:

- While cranking the engine:

The duration defined below is used.

- Duration of fuel injection during engine start-up ..... Determined according to the engine coolant temperature detected by the engine coolant temperature sensor.

- During normal operation:

The duration is determined as follows:

Basic duration of fuel injection  $\times$  Correction factors + Voltage correction time

- Basic duration of fuel injection ..... The basic length of time fuel is injected. This is determined by two factors — the amount of intake air detected by the air flow sensor and the engine speed monitored by the crankshaft position sensor.
- Correction factors ..... See the next section.
- Voltage correction time ..... This is added to compensate for the time lag before operation of injector that results from variation in the battery voltage.

#### 2. CORRECTION FACTORS

The following factors are used to correct the basic duration of fuel injection in order to make the air-fuel ratio meet the requirements of varying engine operating conditions:

- Air-fuel ratio feedback factor:

This factor is used to correct the basic duration of fuel injection in relation to the actual engine speed. (See the next section for more details.)

- Start increment factor:

This factor is used to increase the fuel injection duration only while the engine is being cranked to improve its start ability.

- Coolant-temperature-dependent increment factor:

This factor is used to increase the fuel injection duration depending on engine coolant temperature signals to facilitate cold starting. The lower the coolant temperature, the greater becomes the increment.

- After-start increment factor:

- This factor is used to increase the fuel injection duration for a certain period immediately after start of the engine to stabilize engine operation.
- The increment depends on the coolant temperature at the start of the engine.

Brought to you by *www.EngineeringBooksPdf.com*  
NOT FOR SALE

- **Wide-open-throttle increment factor:**

This factor is used to increase the fuel injection duration depending on the relationship between the throttle position sensor signal and air flow sensor signal.

- **Acceleration increment factor:**

This factor is used to increase the fuel injection duration to compensate for a time lag between air flow measurement and fuel injection control for better engine response to driver's pedal operation during acceleration.

### 3. AIR-FUEL RATIO FEEDBACK FACTOR

The ECM creates this factor utilizing the front oxygen (A/F) sensor signal. When the signal is high, the air-fuel ratio is leaner than the stoichiometric ratio. The ECM then makes the fuel injection duration longer by modifying the factor. When the signal is low showing that the mixture is rich, the ECM modifies the factor to make the injection duration shorter. In this way, the air-fuel ratio is maintained at a level close to the stoichiometric ratio at which the three-way catalytic converter acts most effectively.

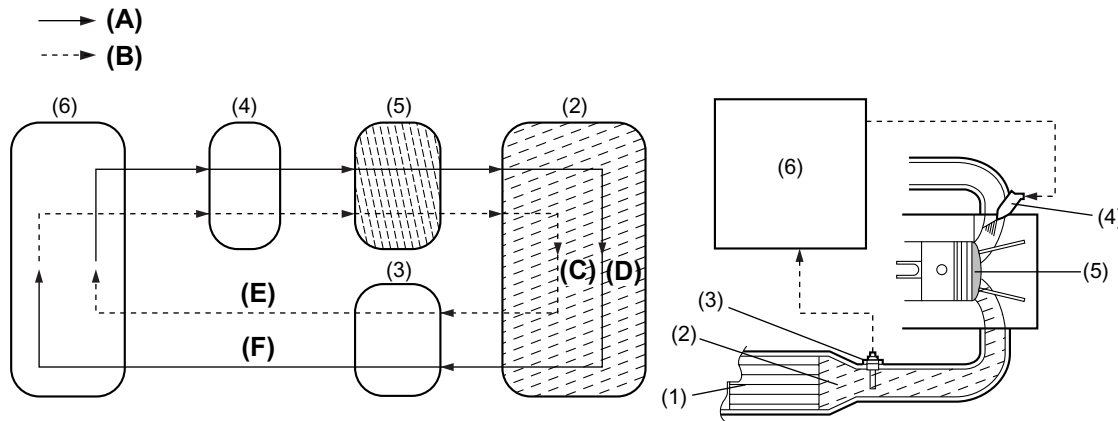

FU-00240

- (1) Front catalytic converter
- (2) Exhaust gases
- (3) Front oxygen (A/F) sensor
- (4) Fuel injector
- (5) Combustion chamber
- (6) ECM

- (A) Injection duration increment signal
- (B) Injection duration decrement signal
- (C) High oxygen density
- (D) Low oxygen density
- (E) Lean signal
- (F) Rich signal

### 4. LEARNING FEATURE

The air-fuel ratio feedback control includes a learning feature, which contributes to more accurate and responsive control.

- In the air-fuel ratio feedback control, the ECM calculates the necessary amount of correction based on data from the front oxygen (A/F) sensor and adds the result to the basic duration (which is stored in the ECM's memory for each condition defined by the engine speed and various loads.)
- Without a learning feature, the ECM carries out the above-mentioned process every time. This means that if the amount of necessary correction is large, the air-fuel ratio feedback control becomes less responsive and less accurate.
- The learning feature enables the ECM to store the amount of correction into memory, and takes it into account with the basic fuel injection duration to create a new reference fuel injection duration. Using the reference duration as the basic duration for the injection a few times later, the ECM can reduce the amount of correction and thus make its feedback control more accurate and responsive to changes in the air-fuel ratio due to difference in driving condition and sensor/actuator characteristics that may result from unit-to-unit variation or aging over time.

Brought to you by *www.EngineeringBooksPdf.com*  
 NOT FOR SALE

## D: IGNITION CONTROL

- The ECM determines operating condition of the engine based on signals from the manifold absolute pressure sensor, engine coolant temperature sensor, intake air temperature sensor, crankshaft position sensor and other sources. The ECM then selects the ignition timing most appropriate for the condition thus determined from those stored in its memory and outputs at that timing a primary current OFF signal to the igniter to initiate ignition.
- This control uses a quick-to-response learning feature by which the data stored in the ECM memory is processed in comparison with information from various sensors and switches.
- Thus, the ECM can always perform optimum ignition timing taking into account the output, fuel efficiency, exhaust gas, and other factors for every engine operating condition.
- Ignition control during start-up  
 Engine speed fluctuates during start of the engine, so the ECM cannot control the ignition timing. During that period, the ignition timing is fixed at 10° BTDC by using the 10° signal from the crankshaft position sensor.

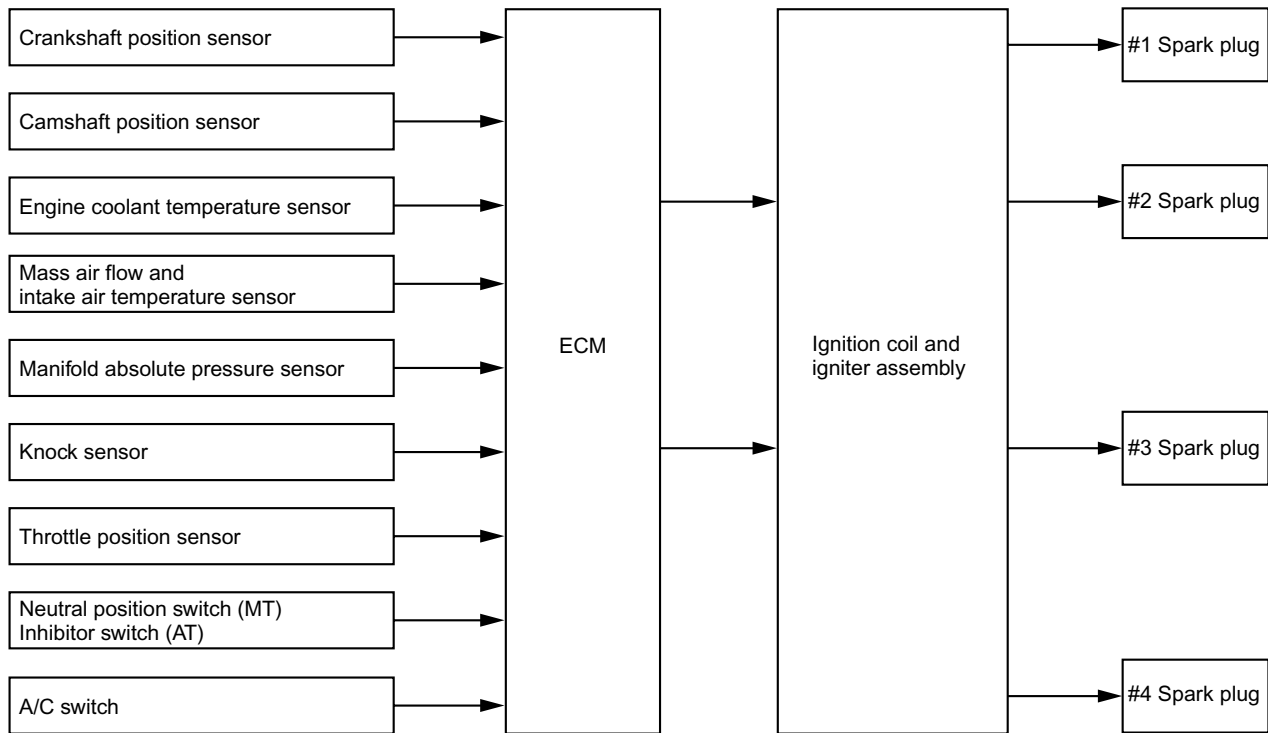

FU-02412

# CONTROL SYSTEM

## FUEL INJECTION (FUEL SYSTEM)

Brought to you by Eris Studios  
NOT FOR RESALE

### ● Ignition control after start of engine

From the time to receive crank angle signals indicating 180° of a turn, the ECM measures the engine speed, and by using this data it decides the dwell set timing and ignition timing according to the engine condition.

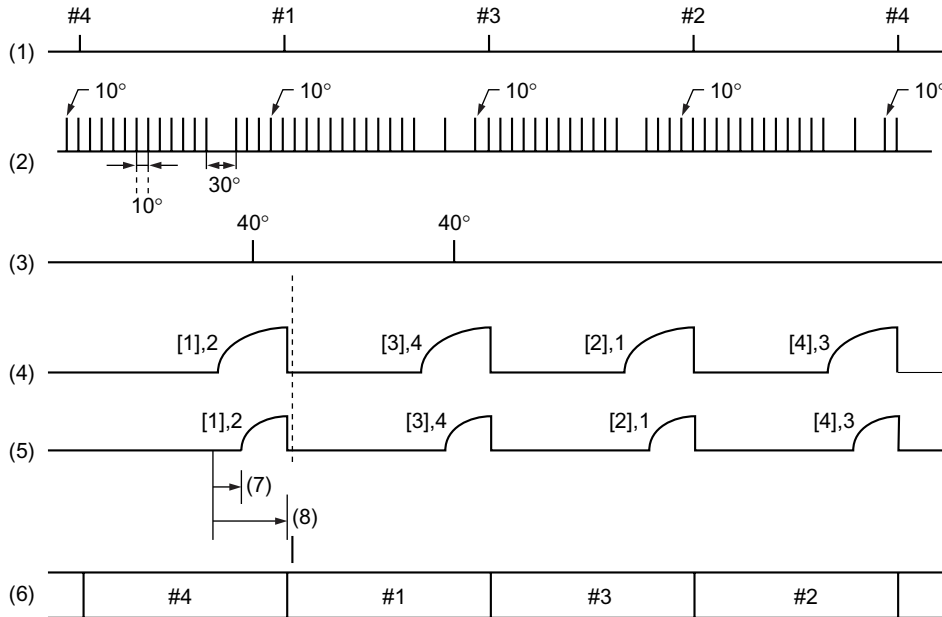

FU-02019

- |                                 |   |
|---------------------------------|---|
| (1) Cylinder number             | (5) Ignition timing under normal conditions |
| (2) Crank angle pulse (BTDC)    | (6) Cylinder at combustion                  |
| (3) Cam angle pulses (BTDC)     | (7) Dwell set                               |
| (4) Ignition timing at starting | (8) Ignition                                |

Brought to you by Studios  
NOT FOR SALE

## E: IDLE AIR CONTROL

- The ECM controls the electronic control throttle based on signals from the crankshaft position sensor, engine coolant temperature sensor, manifold absolute pressure sensor and A/C switch so that the proper idle speed for each engine load is achieved.

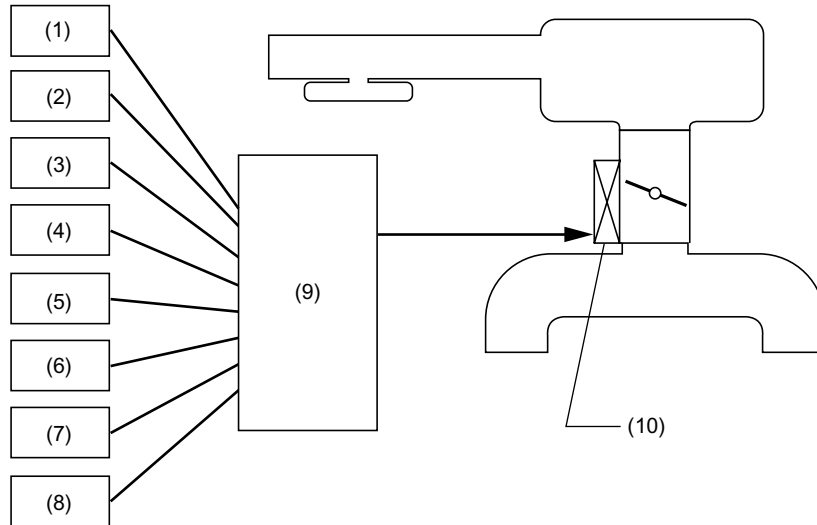

FU-01238

- |                                       |   |
|---------------------------------------|---|
| (1) Crankshaft position sensor        | (6) Ignition switch                                     |
| (2) Camshaft position sensor          | (7) A/C switch  |
| (3) Throttle position sensor          | (8) Neutral position switch (MT), inhibitor switch (AT) |
| (4) Engine coolant temperature sensor | (9) ECM   |
| (5) Manifold absolute pressure sensor | (10) Electronic control throttle                        |

## F: FUEL PUMP CONTROL

Using the signal from the crankshaft position sensor, the ECM controls operation of the fuel pump by turning its relay ON or OFF. To improve safety, the fuel pump is stopped if the engine stalls with the ignition switch ON.

Ignition switch ON	Fuel pump relay	Fuel pump
A certain period of time after ignition switch is turned ON	ON	Operates
While cranking the engine	ON	Operates
While engine is operating	ON	Operates
When engine stops	OFF	Does not operate

# ON-BOARD DIAGNOSIS SYSTEM

## FUEL INJECTION (FUEL SYSTEM)

---

Brought to you by Eris Studios  
NOT FOR RESALE

### 6. On-board Diagnosis System

#### A: GENERAL

- The on-board diagnosis system detects and indicates a fault by generating a code corresponding to each fault location. The malfunction indicator light on the combination meter indicates occurrence of a fault or abnormality.
- When the malfunction indicator light comes on as a result of detection of a fault by the ECM, the corresponding diagnostic trouble code (DTC) and freeze frame engine condition are stored in the ECM.
- On the OBD-II conformable car, it is necessary to connect the SUBARU Select Monitor (SSM) or General Scan Tool (GST) to the data link connector in order to check the DTC.
- The SSM and GST can be used for erasing DTCs. These can also read freeze frame data in addition to other pieces of engine data.
- If there is a failure involving sensors, which may affect drive control of the vehicle, the fail-safe function ensures minimum level of drivability.

#### B: FAIL-SAFE FUNCTION

For a sensor or switch that has been judged to be faulty by the on-board diagnosis, the ECM generates a pseudo signal to keep the vehicle operational. (The control becomes degraded.)