

Brought to you by Eris Studios  
NOT FOR RESALE

# LIGHTING SYSTEM

### 1. Front A: GENERAL

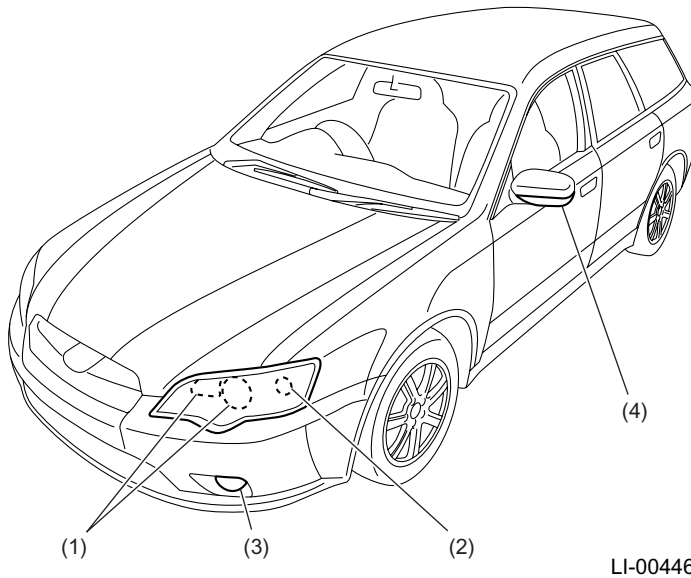

- |                                                        |                            |
|--------------------------------------------------------|----------------------------|
| (1) Headlight                                          | (3) Front fog light        |
| (2) Front turn signal/parking, front side marker light | (4) Side turn signal light |

- The headlight of all models consists of four halogen bulbs, and projector type low beam lights are used.
- The front turn signal/hazard warning light, parking/front side marker light and the front side reflex reflector are incorporated into the headlight.
- The fog light is either of a projector type or a large sized multiple reflector type.
- On some models, the side turn signal lights are built into the lower part of the door mirrors to improve visibility. Also, LEDs (light emitting diodes) are used for light source to improve the durability.

## 2. Rear

### A: GENERAL

#### Sedan models

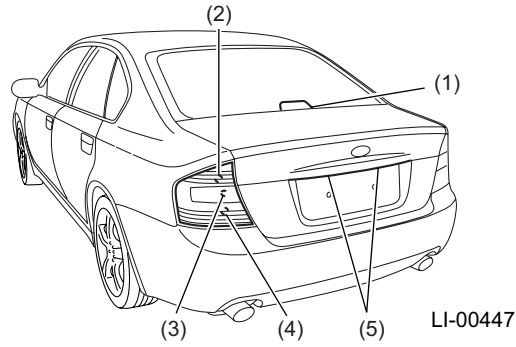

(1) High mount stop light

(2) Turn signal/hazard warning light

(3) Backup light

(4) Stop/tail/rear side marker light

(5) License plate light

#### Wagon models

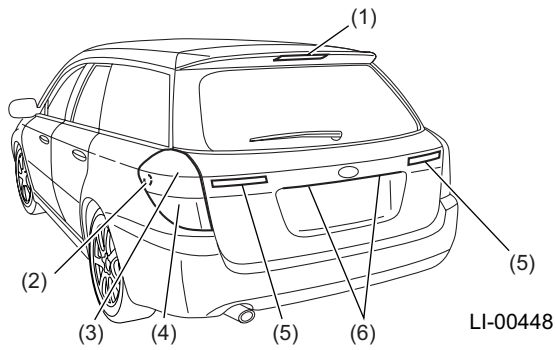

(1) High mount stop light

(2) Rear side marker light

(3) Stop/tail light

(4) Turn signal/hazard warning light

(5) Backup light

(6) License plate light

## REAR

### LIGHTING SYSTEM

---

Brought to you by Eris Studios  
NOT FOR RESALE

- On sedan models, the rear turn signal/hazard warning light, stop/tail/rear side marker light, and the backup light are incorporated into the rear combination light. On wagon models, the rear turn signal/hazard warning light, stop/tail light, and the rear side marker light are incorporated into the rear combination light. On both the sedans and wagons, the rear reflex reflector and the rear side reflex reflector are incorporated into the rear combination light. On wagons, the backup lights are built in the rear gate garnish.
- The high mount stop light is installed to the bottom inside of the rear window on sedans, and to the rear of the roof spoiler on wagons.
- By using LEDs (light emitting diodes) as light source for the high mount stop light on wagon models, space is saved, efficiency is improved, and power consumption is reduced while the durability is improved.