

Brought to you by Eris Studios
NOT FOR RESALE

HVAC SYSTEM (HEATER, VENTILATOR, AND A/C)

General Description

HVAC SYSTEM (HEATER, VENTILATOR AND A/C)

Brought to you by Eris Studios
NOT FOR RESALE

1. General Description

A: SPECIFICATION

1. HEATER SYSTEM

Item		Specification	Condition
Heating capacity		5.0 kW (4,299 kcal/h, 17,059 BTU/h) or more	<ul style="list-style-type: none"> Mode selector switch: HEAT Temperature control switch: FULL HOT Temperature difference between hot water and inlet air: 65°C (149°F) Hot water flow rate: 360 ℓ (95.1 US gal, 79.2 Imp gal)/h
Air flow rate		290 m ³ (10,243 cu ft)/h	Heat mode (FRESH), FULL HOT at 12.5 V
Max air flow rate		480 m ³ (16,954 cu ft)/h	<ul style="list-style-type: none"> Temperature control switch: FULL COLD Blower fan speed: Auto A/C: 7th position Mode selector lever: RECIRC
Heater core size (height × length × width)		257.5 × 118.5 × 27 mm (10.1 × 4.67 × 1.06 in)	—
Blower motor	Type	Magnet motor 250 W or less	12 V
	Fan type and size (diameter × width)	Sirocco fan type 150 × 75 mm (5.91 × 2.95 in)	—

2. A/C SYSTEM

Item		Specification
Type of air conditioner		Reheat air-mix type
Cooling capacity		5.0 kW [at 480 m ³ (16,954 cu ft)/h] (4,299 kcal/h, 17,059 BTU/h)
Refrigerant		HFC-134a (CH ₂ FCF ₃) [0.5±0.03 kg (1.1±0.07 lb)]
Compressor	Type	Rotary, constant volume (DVK-10R)
	Discharge	105 cc (6.41 cu in)/rev
	Max. permissible speed	7,700 rpm
Magnet clutch	Type	Dry, single-disc type
	Power consumption	38.8 W
	Type of belt	V-belt 4 PK
	Pulley dia. (effective dia.)	100 mm (3.9 in)
	Pulley ratio	1.32
Condenser	Type	Sub cool type
	Core face area	0.188 m ² (2.002 sq ft)
	Core thickness	16 mm (0.63 in)
	Radiation area	4.5 m ² (48.44 sq ft)
Receiver drier	Effective inner capacity	177 cm ³ (10.8 cu in)
Expansion valve	Type	Block
Evaporator	Type	Double tank
	Dimensions (W × H × T)	290.1 × 172 × 39 mm (11.42 × 6.77 × 1.54 in)
Blower fan	Fan type	Sirocco fan
	Outer diameter × width	150 × 75 mm (5.91 × 2.95 in)
	Power consumption	250 W
Condenser fan (Sub fan)	Motor type	Magnet
	Power consumption	120 W
	Fan outer diameter	318.5 mm (12.5 in)

General Description

HVAC SYSTEM (HEATER, VENTILATOR AND A/C)

Brought to you by Eris Studios
 NOT FOR SALE

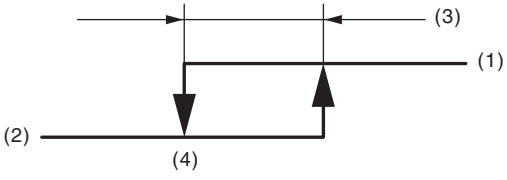
Item		Specification	
Radiator fan (Main fan)	Motor type	Magnet	
	Power consumption	120 W	
	Fan outer diameter	318.5 mm (12.5 in)	
Idling speed (A/C ON, sub fan ON)		MPFI model	800±50 rpm
Triple switch (Pressure switch)	Low pressure switch operating pressure	ON → OFF	177±25 kPa (1.80±0.25 kgf/cm ² , 25.7±3.6 psi)
		OFF → ON	206±30 kPa (2.10±0.31 kgf/cm ² , 29.9±4.3 psi)
	High pressure switch operating pressure	ON → OFF	2,940±200 kPa (29.98±2.04 kgf/cm ² , 426.3±29 psi)
		OFF → ON	2,350±200 kPa (24.00±2.04 kgf/cm ² , 340.7±29.0 psi)
	Middle-pressure switch operating pressure	ON → OFF	1,470±120 kPa (14.99±1.22 kgf/cm ² , 213.15±17.4 psi)
		OFF → ON	1,770±100 kPa (18.05±1.02 kgf/cm ² , 256.65±14.5 psi)
Thermo-control amplifier working temperature		 <p style="text-align: right;">AC-00601</p> <p>(1) ON (2) OFF (3) 1.5±0.3°C (34.7±0.5°F) (4) 1.0±0.5°C (33.8±0.9°F)</p>	

General Description

HVAC SYSTEM (HEATER, VENTILATOR AND A/C)

Brought to you by Eris Studios
NOT FOR RESALE

B: COMPONENT

1. HEATER COOLING UNIT

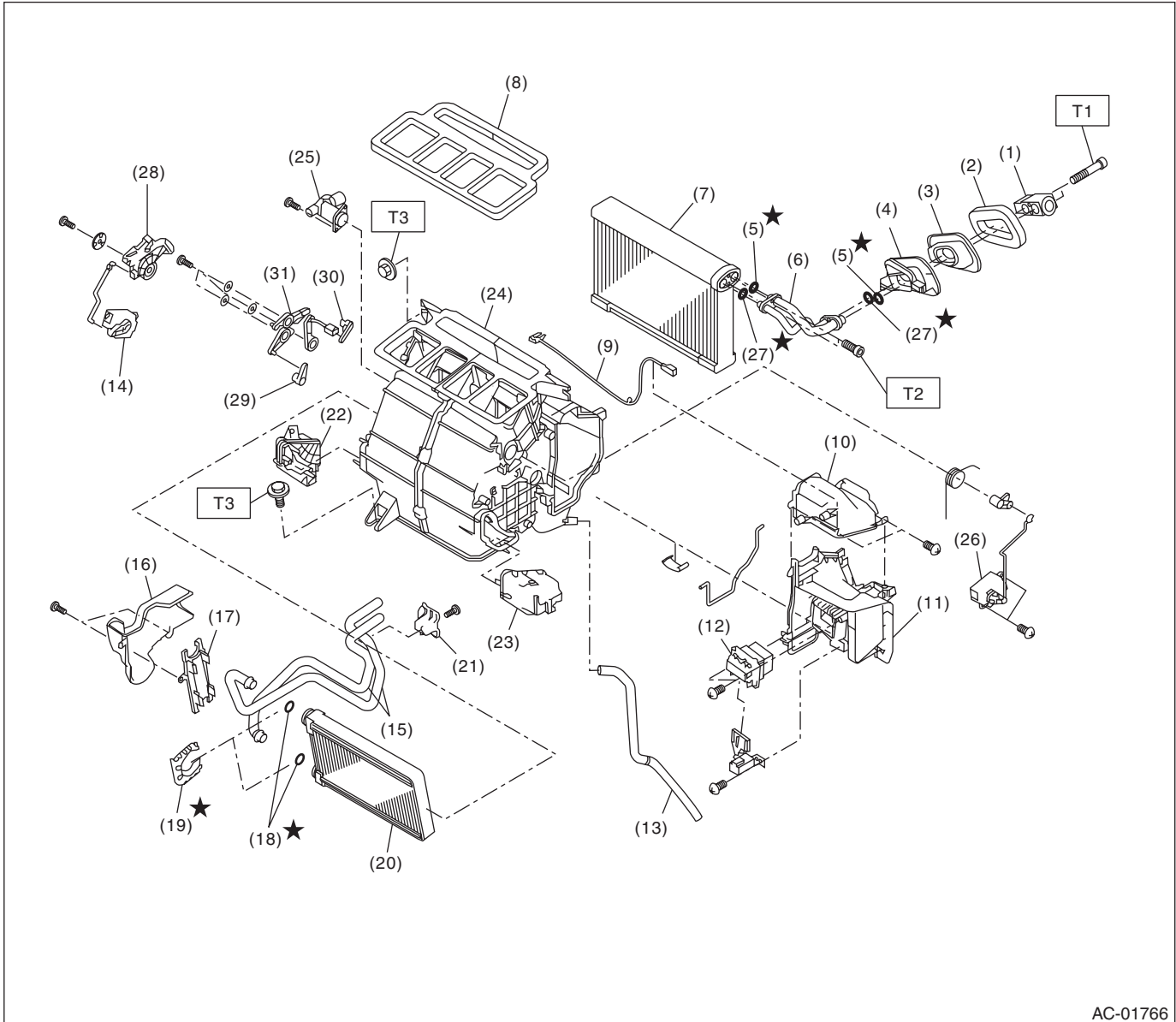

AC-01766

- | | | |
|----------------------------|------------------------|--------------------------|
| (1) Expansion valve | (13) Drain hose | (25) Aspirator |
| (2) Gasket | (14) Mode actuator | (26) Air mix actuator |
| (3) Grommet | (15) Heater core pipe | (27) O-ring |
| (4) Case | (16) Heater pipe cover | (28) Mode main lever |
| (5) O-ring | (17) Heater core cover | (29) Vent door link |
| (6) Evaporator pipe | (18) O-ring | (30) Defroster door link |
| (7) Evaporator | (19) Clamp | (31) Mode link |
| (8) Lining | (20) Heater core | |
| (9) Evaporator sensor | (21) Pipe clamp | |
| (10) Evaporator pipe cover | (22) Foot duct (LH) | |
| (11) Evaporator cover | (23) Foot duct (RH) | |
| (12) Power transistor | (24) Heater case | |

Tightening torque: N·m (kgf·m, ft·lb)

T1: 5.0 (0.5, 3.7)

T2: 6.68 (0.7, 4.9)

T3: 7.5 (0.76, 5.5)

General Description

HVAC SYSTEM (HEATER, VENTILATOR AND A/C)

Brought to you by Eris Studios
NOT FOR SALE

2. BLOWER MOTOR UNIT

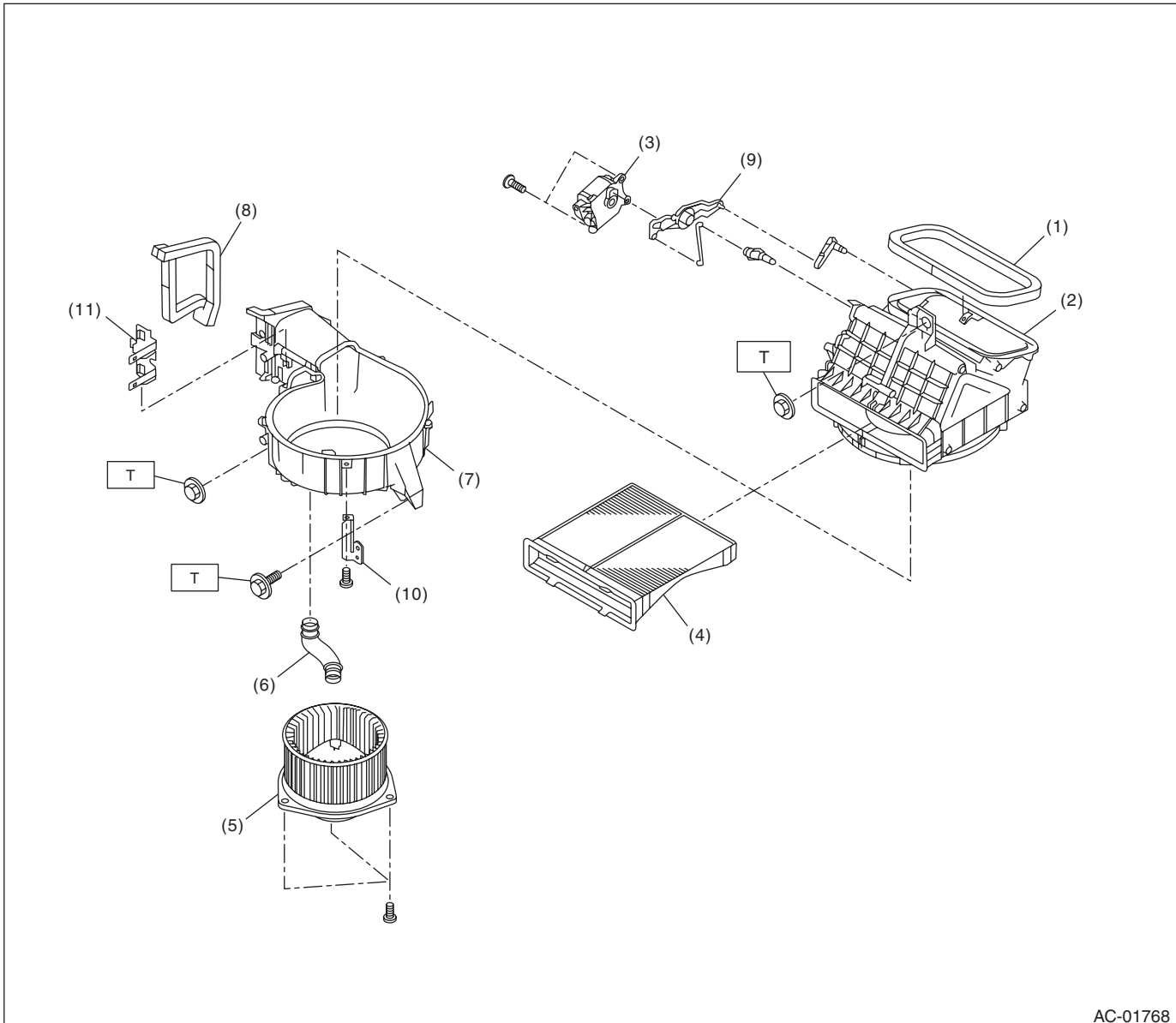

AC-01768

- | | | |
|--------------------------|----------------------|---------------------------|
| (1) Lining | (6) Hose | (11) Relay holder bracket |
| (2) Upper case | (7) Lower case | |
| (3) Intake door actuator | (8) Lining | |
| (4) Filter | (9) Intake door link | |
| (5) Blower motor ASSY | (10) Relay bracket | |

Tightening torque: N·m (kgf·m, ft·lb)
T: 7.5 (0.76, 5.5)

General Description

HVAC SYSTEM (HEATER, VENTILATOR AND A/C)

Brought to you by Eris Studios
NOT FOR RESALE

3. CONTROL MODULE

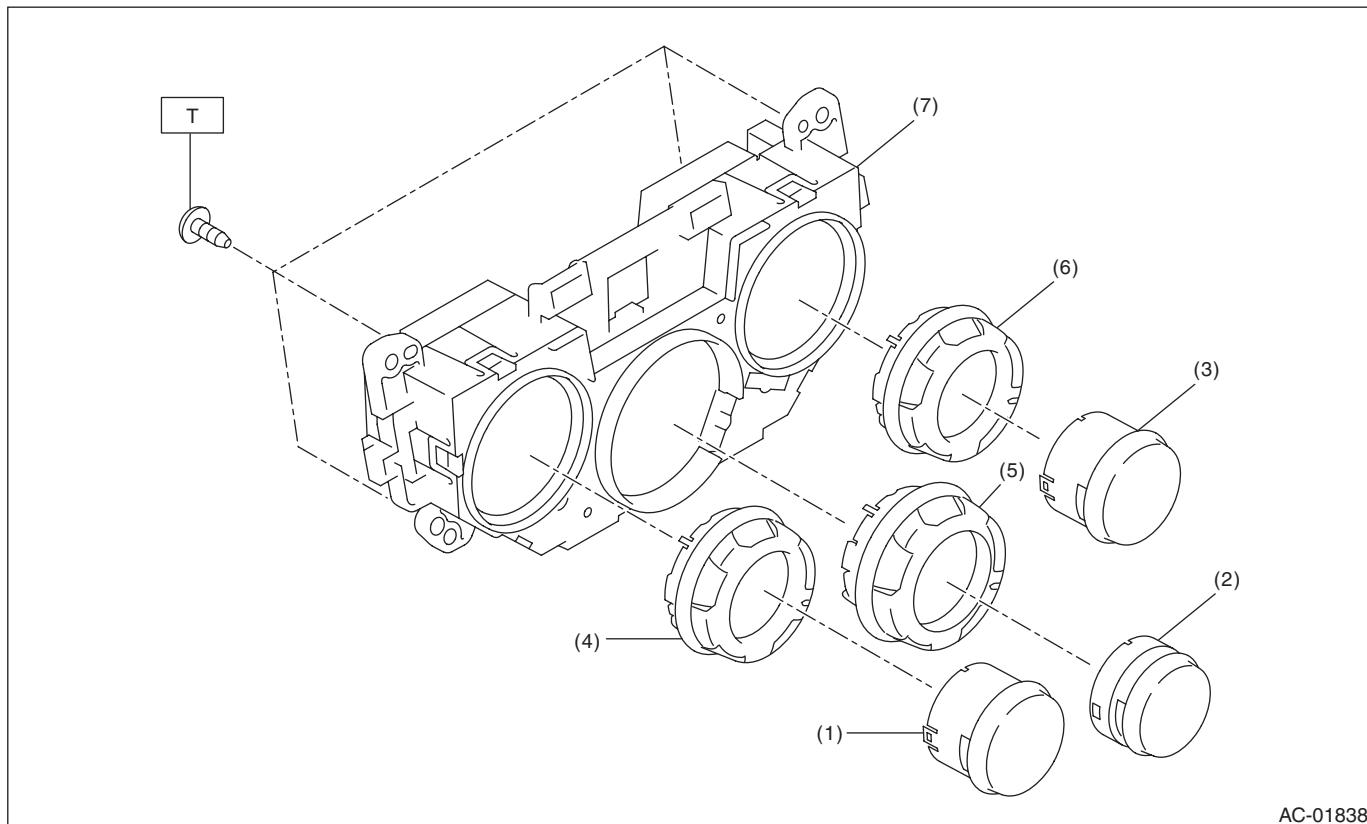

AC-01838

- (1) FRESH/RECIRC switch
- (2) Rear defogger switch
- (3) A/C switch
- (4) Fan speed control dial

- (5) Mode control dial
- (6) Temperature adjustment dial
- (7) Control case

Tightening torque: N·m (kgf·m, ft·lb)

T: 2 (0.2, 1.48)

General Description

HVAC SYSTEM (HEATER, VENTILATOR AND A/C)

Brought to you by Eris Studios
NOT FOR SALE

4. AIR CONDITIONING UNIT

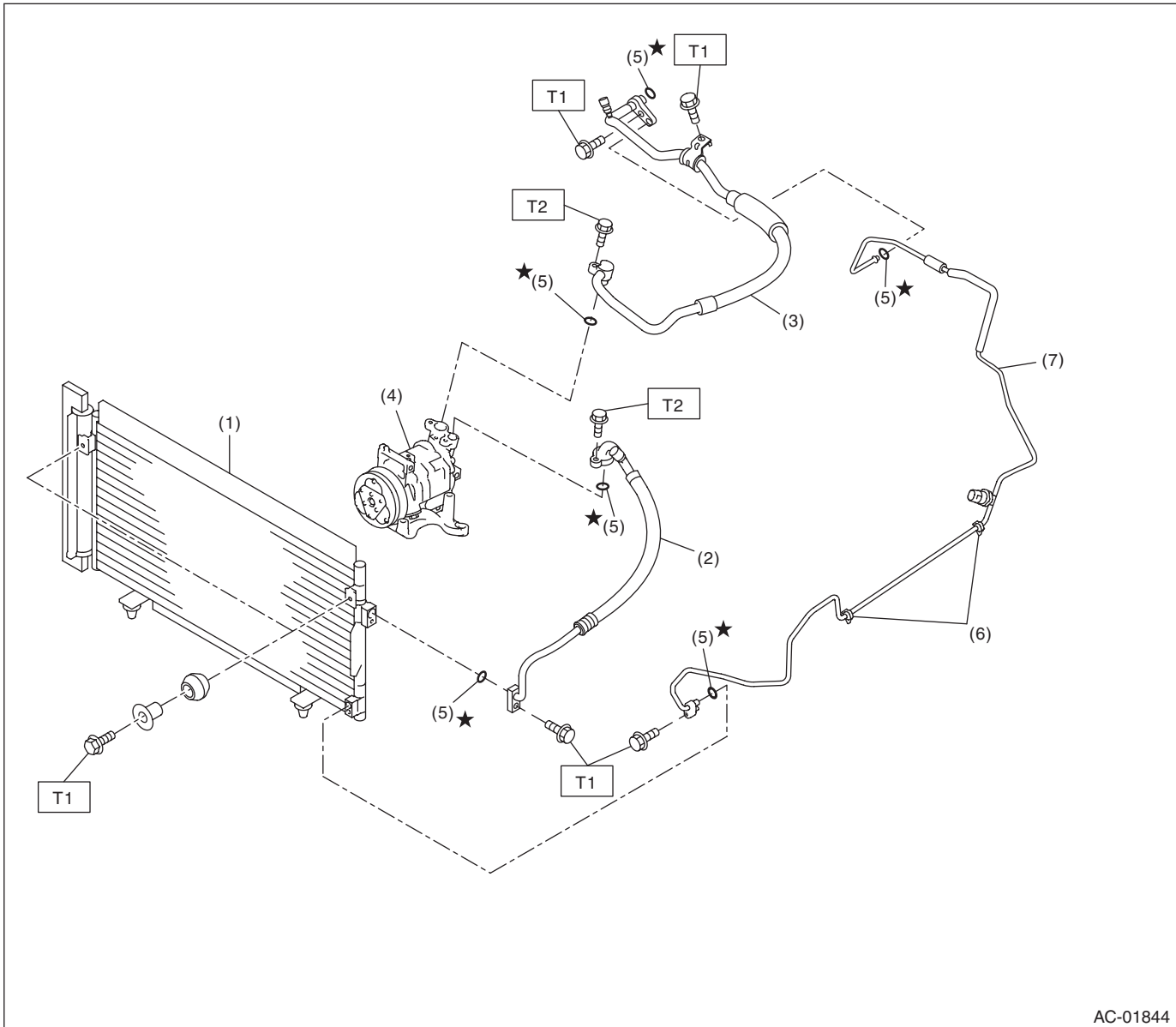

AC-01844

- | | |
|--------------------------|------------|
| (1) Condenser | (5) O-ring |
| (2) Hose (High pressure) | (6) Clamp |
| (3) Hose (Low pressure) | (7) Pipe |
| (4) Compressor | |

Tightening torque: N·m (kgf·m, ft·lb)

T1: 7.5 (0.76, 5.5)

T2: 10 (1.0, 7.4)

General Description

HVAC SYSTEM (HEATER, VENTILATOR AND A/C)

Brought to you by Eris Studios
NOT FOR RESALE

5. COMPRESSOR

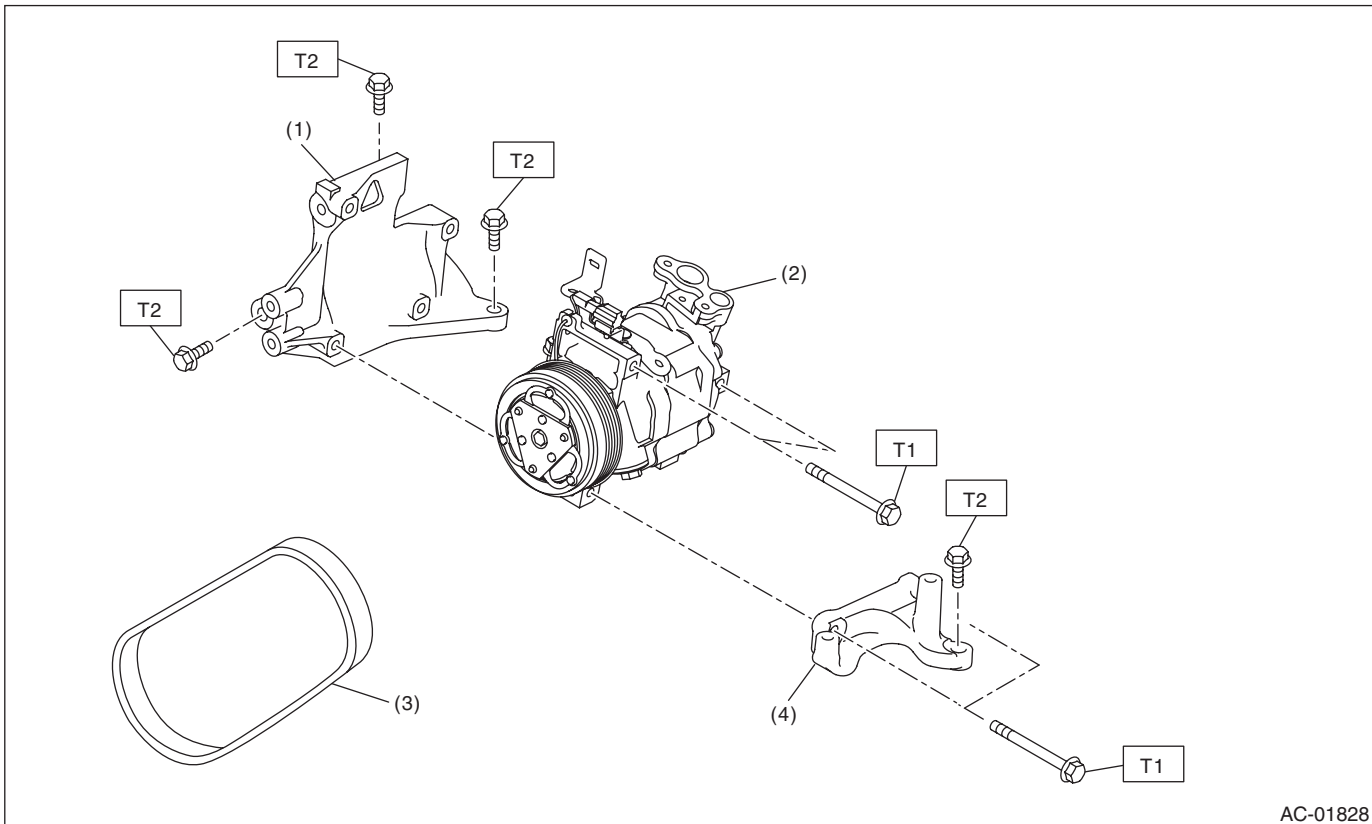

- (1) Compressor bracket
- (2) Compressor
- (3) V-belt
- (4) Compressor bracket

Tightening torque: N-m (kgf-m, ft-lb)
T1: 26.5 (2.7, 19.5)
T2: 36 (3.7, 26.6)

General Description

HVAC SYSTEM (HEATER, VENTILATOR AND A/C)

Brought to you by Eris Studios
NOT FOR SALE

6. HEATER DUCT

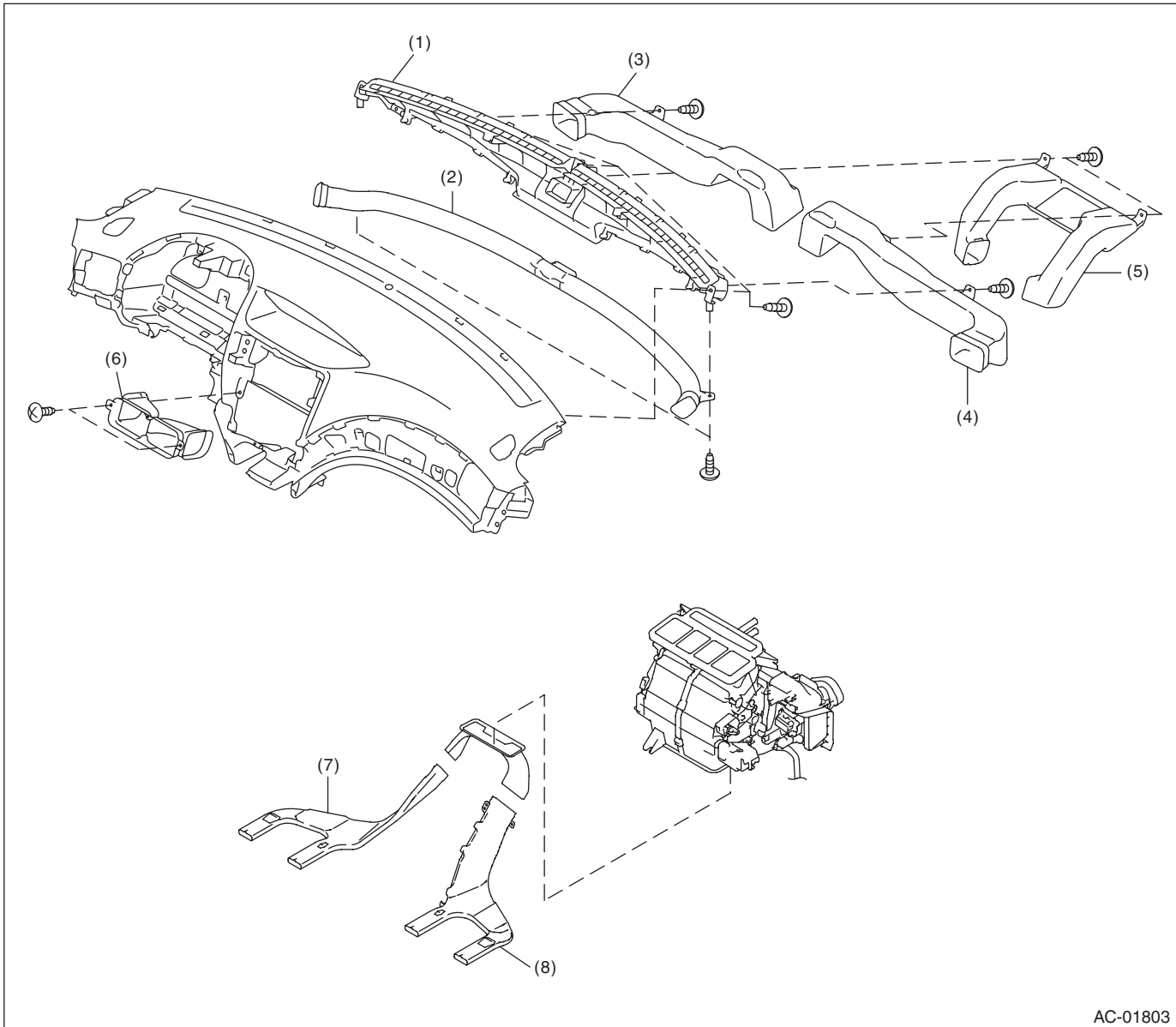

AC-01803

- (1) Front defroster nozzle
- (2) Side defroster duct
- (3) Side ventilation duct (LH)

- (4) Side ventilation duct (RH)
- (5) Center ventilation duct (A)
- (6) Center ventilation duct (B)

- (7) Rear heater duct (LH)
- (8) Rear heater duct (RH)

General Description

HVAC SYSTEM (HEATER, VENTILATOR AND A/C)

Brought to you by Eris Studios
NOT FOR RESALE

C: CAUTION

1. HFC-134A A/C SYSTEM

- The cooling system components for the HFC-134a system such as the refrigerant and compressor oil are different from the conventional CFC-12 system components and they are incompatible with each other.
- Vehicles with the HFC-134a system can be identified by the label (A) attached to the vehicle. Before maintenance, check which A/C system is installed to the vehicle.

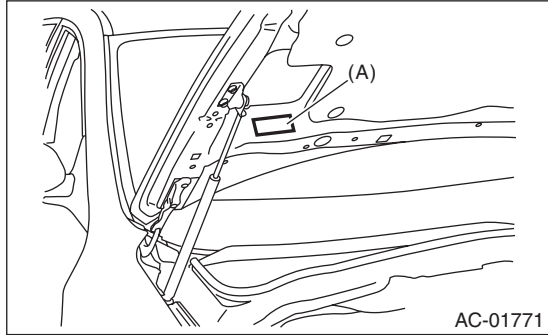

2. COMPRESSOR OIL

- HFC-134a compressor oil has no compatibility with that of CFC-12 system.
 - Use only the manufacturer-authorized compressor oil for the HFC-134a system; only use DH-PR (ZXL200PG).
 - Do not mix multiple compressor oils.
- If CFC-12 compressor oil is used in the HFC-134a A/C system, the compressor may become stuck due to poor lubrication, or the refrigerant may leak due to swelling of rubber parts.
- On the other hand, if HFC-134a compressor oil is used in a CFC-12 A/C system, the durability of the A/C system will be lowered.
- HFC-134a compressor oil is very hygroscopic. When replacing or installing/removing A/C parts, immediately isolate the oil from atmosphere using a plug or tape. In order to avoid moisture, store the oil in a container with its cap tightly closed.

3. REFRIGERANT

- CFC-12 refrigerant cannot be used in a HFC-134a A/C system. HFC-134a refrigerant, also cannot be used in a CFC-12 A/C system.
- If an incorrect or no refrigerant is used, it will result in poor lubrication and the compressor itself may be damaged.

4. HANDLING OF REFRIGERANT

- The refrigerant boils at approx. -30°C (-22°F). When handling it, be sure to wear protective goggles and protective gloves. Direct contact of the refrigerant with skin may cause frostbite. If the refrigerant gets into your eye, avoid rubbing your eyes with your hands. Wash your eye with plenty of water, and receive medical treatment from an eye doctor.
- Do not heat a service can. If a service can is directly heated, or put into boiling water, the inside pressure will become extremely high. This may cause the can to explode. If a service can must be warmed up, use warm water of 40°C (104°F) or less.
- Do not drop or impact a service can. (Observe the precautions and operation procedure described on the refrigerant can.)
- When the engine is running, do not open the high-pressure valve of the manifold gauge. High pressure gas may backflow, causing the can to explode.
- Provide good ventilation and do not work in a closed area.
- In order to prevent global warming, avoid releasing HFC-134a into the atmosphere. Using a refrigerant recovery system, discharge and recycle the gas.

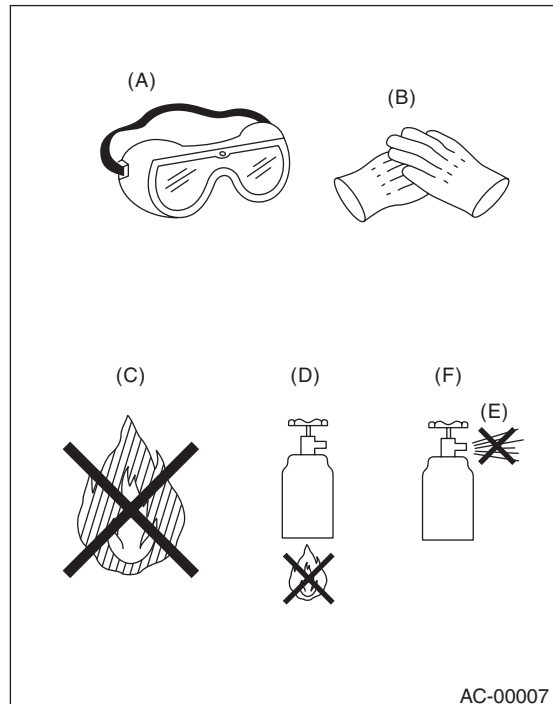

- (A) Goggles
- (B) Gloves
- (C) Avoid open flame
- (D) No direct heat on container
- (E) Do not discharge
- (F) Loosen

General Description

HVAC SYSTEM (HEATER, VENTILATOR AND A/C)

Brought to you by Eris Studios
NOT FOR SALE

5. O-RING CONNECTIONS

- Always use a new O-ring.
- In order to keep the O-rings free of lint which will cause a refrigerant gas leak, perform work without using gloves or waste cloths.
- Apply compressor oil to O-rings to avoid sticking, before installation.
- Use a torque wrench to tighten the O-ring fittings. Over-tightening will result in damage of the O-ring and deformation of the pipe end.
- If the work is interrupted before completing pipe connections, recap the pipes, components and fittings with a plug or tape to prevent foreign matter from entering.

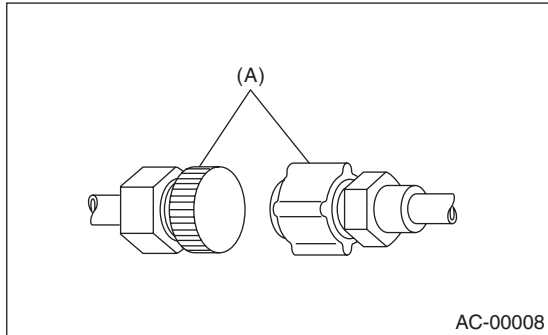

(A) Seal

- Visually check the surfaces and mating surfaces of O-rings, threads and connecting points. If a failure is found, replace the applicable parts.
- Install the O-rings straight against the curb of the pipe.

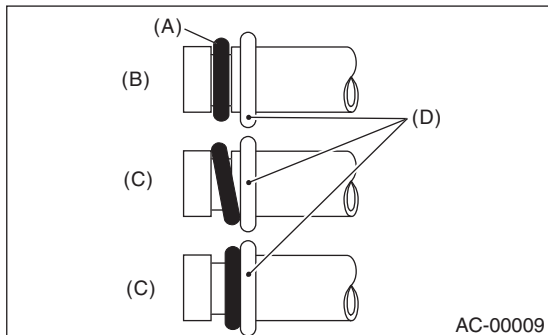

- (A) O-ring
- (B) OK
- (C) NG
- (D) Curb

- Use compressor oil specified in the service manual to lubricate the O-rings. Apply oil to the top and sides of O-rings before installation. Apply compressor oil to grooves of the pipe.

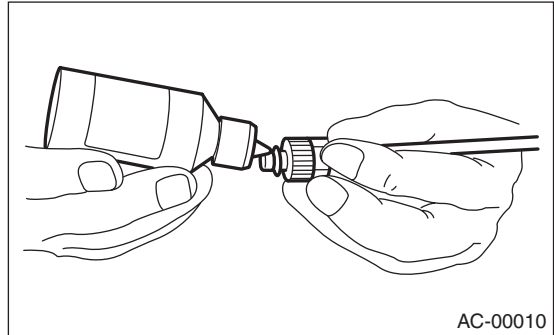

- After tightening, use a clean cloth to remove excess compressor oil from the connections and any oil which may have run on the vehicle body or other parts.
- If any leakage is suspected after tightening, do not tighten the connections further, but disconnect the connections, remove the O-rings, and check the O-rings, threads, and connections.

D: PREPARATION TOOL

CAUTION:

When working on vehicles with a HFC-134a system, only use HFC-134a specified tools and parts. Do not mix CFC-12 tools and parts. If HFC-134a and CFC-12 refrigerant or compressor oil is mixed, it will result in poor lubrication and the compressor itself may be damaged.

In order to prevent the mixing HFC-134a and CFC-12 parts and fluids, the type of tools, screw types, and replacement valves are different. The gas leak detectors for the HFC-134a and CFC-12 systems must also not be interchanged.

	HFC-134a	CFC-12
Tool & screw type	Millimeter size	Inch size
Valve type	Quick joint type	Screw-in type

General Description

HVAC SYSTEM (HEATER, VENTILATOR AND A/C)

Brought to you by Eris Studios
NOT FOR RESALE

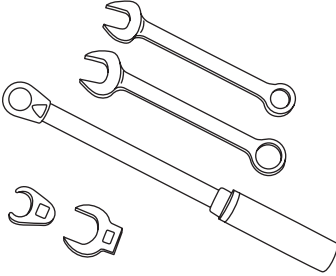
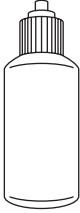
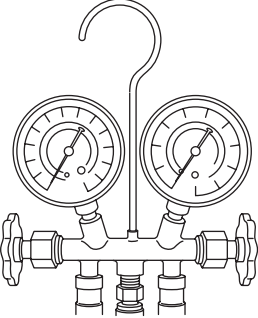
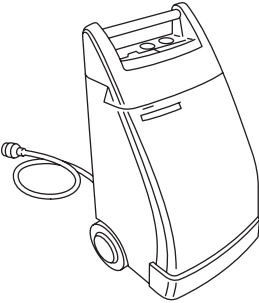
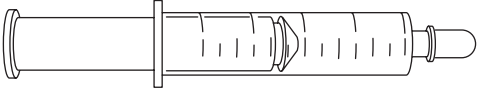
Illustration	Name and Function
 <p data-bbox="597 520 691 541">AC-00213</p>	<p data-bbox="743 207 854 228">WRENCH</p> <p data-bbox="743 243 1487 354">Various WRENCHES will be required to service an A/C system. 7 — 40 N·m (0.7 to 4.1 kgf-m, 5 to 30 ft-lb) torque wrench and various crow-foot wrenches will be needed. Open end or flare nut wrenches will be needed to hold the tube and hose fittings.</p>
 <p data-bbox="597 871 691 892">AC-00012</p>	<p data-bbox="743 558 919 579">Applicator bottle</p> <p data-bbox="743 594 1484 648">A small APPLICATOR BOTTLE is recommended to apply compressor oil to the various parts. It can be available at a hardware or drug store.</p>
 <p data-bbox="597 1222 691 1243">AC-00013</p>	<p data-bbox="743 909 948 930">Manifold gauge set</p> <p data-bbox="743 945 1438 999">A MANIFOLD GAUGE SET (with hoses) is available either from a refrigerant supplier or an automotive equipment supplier.</p>
 <p data-bbox="597 1572 691 1593">AC-00014</p>	<p data-bbox="743 1260 1042 1281">Refrigerant recovery system</p> <p data-bbox="743 1295 1484 1379">A REFRIGERANT RECOVERY SYSTEM is used for the recovery and recycling of an A/C system refrigerant after contaminants and moisture have been removed from the refrigerant.</p>
 <p data-bbox="597 1927 691 1948">AC-00015</p>	<p data-bbox="743 1610 829 1631">Syringe</p> <p data-bbox="743 1646 1484 1701">A graduated plastic SYRINGE will be needed to add oil into the system again. A syringe can be available at a pharmacy or drug store.</p>

General Description

HVAC SYSTEM (HEATER, VENTILATOR AND A/C)

Brought to you by Eriss Studios
 NOT FOR SALE

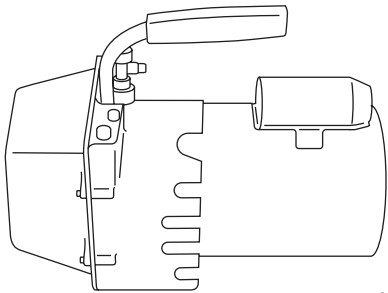
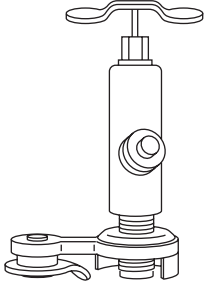
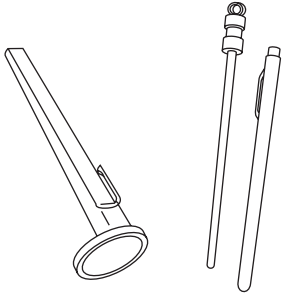
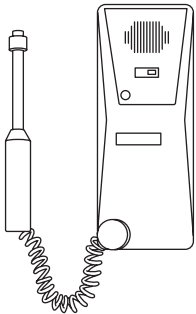
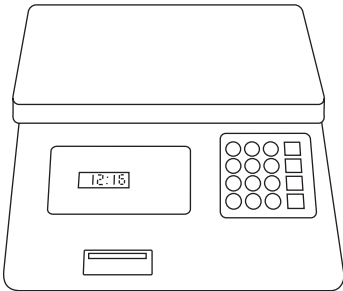
Illustration	Name and Function
 <p style="text-align: right;">AC-00016</p>	<p>Vacuum pump</p> <p>A VACUUM PUMP is necessary (for a good working condition), and is available either at a refrigerant supplier or an automotive equipment supplier.</p>
 <p style="text-align: right;">AC-00017</p>	<p>Can tap</p> <p>A CAN TAP for the 397 g (14 oz.) can is available at an automotive equipment supplier.</p>
 <p style="text-align: right;">AC-00018</p>	<p>Thermometer</p> <p>A Pocket THERMOMETER is available either at a industrial hardware store or a refrigerant supplier.</p>
 <p style="text-align: right;">AC-00019</p>	<p>Electronic leak detector</p> <p>An ELECTRONIC LEAK DETECTOR is available at either a specialty tool supplier or an A/C equipment supplier.</p>
 <p style="text-align: right;">AC-00020</p>	<p>Weight scale</p> <p>A WEIGHT SCALE such as an electronic charging scale or a bathroom scale with digital display will be needed, if a 13.6 kg (30 lb) refrigerant container is used.</p>

Refrigerant Pressure with Manifold Gauge Set

HVAC SYSTEM (HEATER, VENTILATOR AND A/C)

Brought to you by Eris Studios
NOT FOR RESALE

2. Refrigerant Pressure with Manifold Gauge Set

A: PROCEDURE

- 1) Place the vehicle in the shade and windless condition.
- 2) Open the front hood.
- 3) Connect the manifold gauge set.
- 4) Open the front windows and close all doors.
- 5) Increase the engine to 1,500 rpm.
- 6) Turn the A/C switch to ON.
- 7) Turn the temperature control switch to MAX COOL.
- 8) Put in RECIRC position.
- 9) Turn the blower control switch to HI.
- 10) Read the gauge.

Standard:

Low pressure: 127 — 196 kPa (1.3 — 2.0 kg/cm², 18 — 28 psi)

High pressure: 1,471 — 1,667 kPa (15 — 17 kg/cm², 213 — 242 psi)

Ambient temperature: 30 — 35°C (86 — 95°F)

B: INSPECTION

Symptom	Probable cause	Repair order
High pressure side is unusually high.	<ul style="list-style-type: none">• Defective condenser fan motor• Clogged condenser fin• Too much refrigerant• Air inside the system• Defective receiver dryer	<ul style="list-style-type: none">• Replace the fan motor.• Clean the condenser fin.• Discharge refrigerant.• Replace the receiver dryer.• After evacuating again, charge an appropriate amount of refrigerant.
High pressure side is unusually low.	<ul style="list-style-type: none">• Defective compressor• Not enough refrigerant• Clogged expansion valve• Expansion valve frozen temporarily by moisture.	<ul style="list-style-type: none">• Replace the compressor.• Check for leaks.• Replace the expansion valve.• Fully evacuate the expansion valve.
Low pressure side is unusually high.	<ul style="list-style-type: none">• Defective compressor• Defective expansion valve• Too much refrigerant	<ul style="list-style-type: none">• Replace the compressor.• Replace the expansion valve.• Discharge refrigerant.
Low pressure side is unusually low.	<ul style="list-style-type: none">• Not enough refrigerant• Clogged expansion valve• Expansion valve frozen temporarily by moisture.• Saturated receiver dryer	<ul style="list-style-type: none">• Check for leaks.• Replace the expansion valve.• Replace the receiver dryer.

Refrigerant Recovery Procedure

HVAC SYSTEM (HEATER, VENTILATOR AND A/C)

Brought to you by Eris Studios
NOT FOR SALE

3. Refrigerant Recovery Procedure

A: PROCEDURE

CAUTION:

- During operation, be sure to wear protective goggles and protective gloves.
- Connect the refrigerant recovery system with the manifold gauge set to drain the refrigerant from the A/C system and recycle the gas.
- When recycling the drained refrigerant, keep service cans on hand. Because the recovery rate with the recovery system is approx. 90%, service cans are necessary to charge the refrigerant.
- Follow the detailed operation procedure described in the operation manual attached to the refrigerant recovery system.

- 1) Perform compressor oil return operation. <Ref. to AC-20, PROCEDURE, Compressor Oil.>
- 2) Stop the engine.
- 3) Make sure the valves on the low/high pressure sides of the manifold gauge set are fully closed.

- 4) Install the low/high pressure hoses to the low/high pressure side service ports of the vehicle respectively.

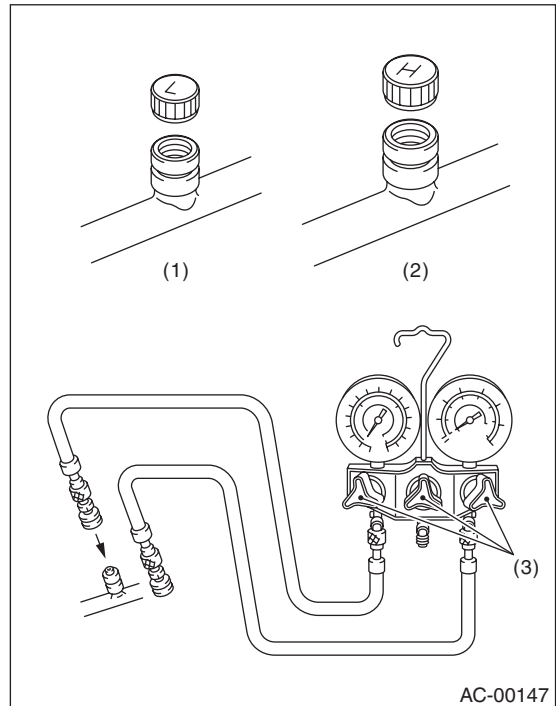

- (1) Low pressure side service port
- (2) High pressure side service port
- (3) Close

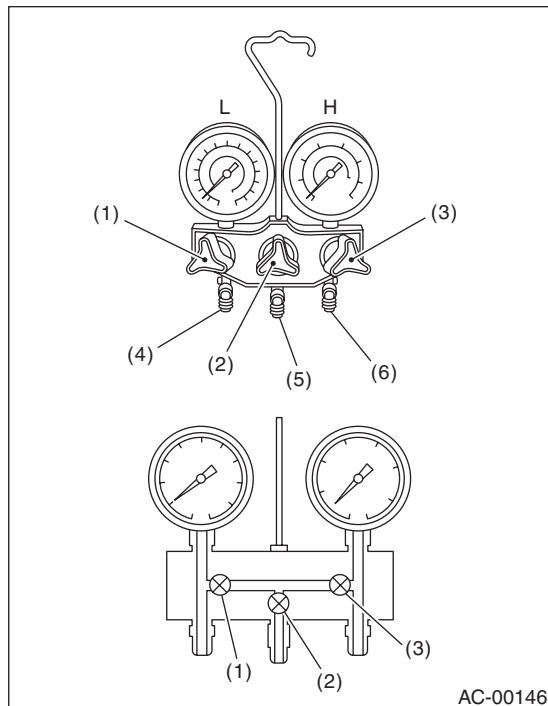

- L: Low pressure gauge
- H: High pressure gauge
- (1) Low pressure valve
- (2) Vacuum pump valve
- (3) High pressure valve
- (4) For low pressure
- (5) For vacuum pump
- (6) For high pressure

- 5) Connect the center hose to the refrigerant recovery system.
- 6) Follow the operation manual to activate the refrigerant recovery system.

Refrigerant Charging Procedure

HVAC SYSTEM (HEATER, VENTILATOR AND A/C)

Brought to you by Eris Studios
NOT FOR RESALE

4. Refrigerant Charging Procedure

A: PROCEDURE

CAUTION:

- While working, make sure to wear protective goggles and gloves.
- Air in the cycle can cause insufficient air conditioning, and water in the cycle can cause clogging in the cycle (icing) and rust. To remove this air and water content, use a vacuum pump to perform evacuation of the system before filling with refrigerant. By making the inside of the cycle a vacuum, the water content will evaporate even at atmospheric temperatures, and can be removed.

1) Close the all valves of the manifold gauge.

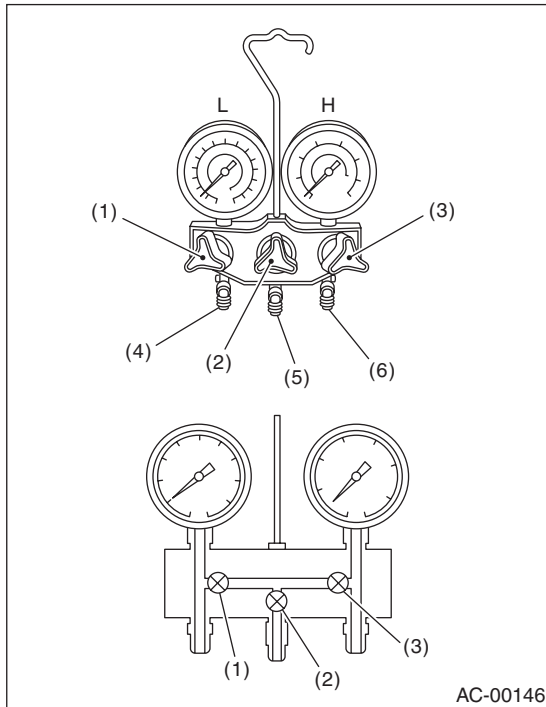

- L: Low pressure gauge
- H: High pressure gauge
- (1) Low pressure valve
- (2) Vacuum pump valve
- (3) High pressure valve
- (4) For low pressure
- (5) For vacuum pump
- (6) For high pressure

2) Attach the low pressure side and high pressure side hoses to the service port of the vehicle.

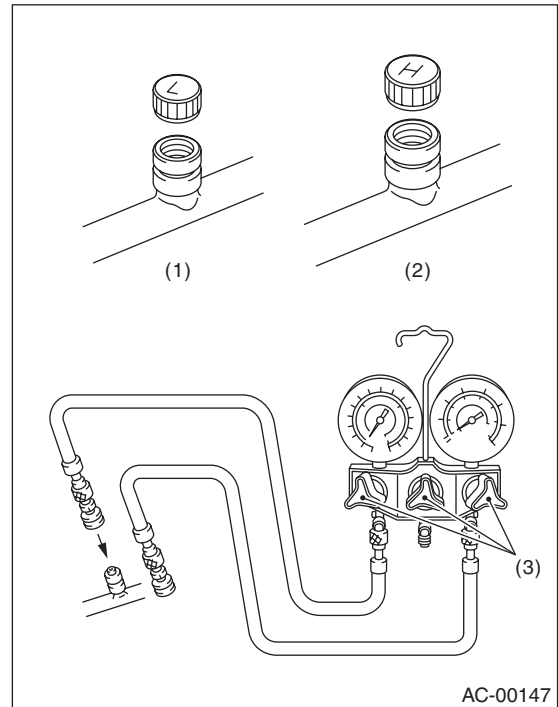

- (1) Low pressure side service port
- (2) High pressure side service port
- (3) Close

CAUTION:

Confirm that the connection is secure.

- 3) Connect the center manifold hose of the manifold gauge to the vacuum pump.
- 4) Operate the vacuum pump and open the low pressure and high pressure side valves. Next, open the center manifold hose valve, and begin evacuation.

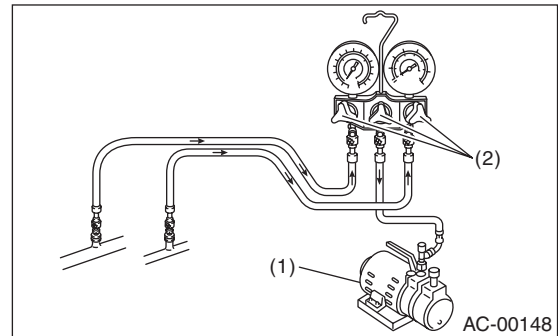

- (1) Vacuum pump
- (2) Open

CAUTION:

Make sure to perform evacuation using a vacuum pump.

Refrigerant Charging Procedure

HVAC SYSTEM (HEATER, VENTILATOR AND A/C)

Brought to you by Eris Studios
NOT FOR SALE

- 5) Perform evacuation for 5 minutes or more, and when the low pressure gauge needle reaches -100.0 kPa (-750 mmHg, -29.5 inHg) or higher, close the center manifold hose valve, and stop the vacuum pump.
- 6) Leave alone for 5 to 10 minutes after closing the low pressure side and high pressure side valves, and check whether there is any change in the low pressure gauge needle indication. If there is a change, this indicates a leak. Check the pipe and hose connections, and check the location with the problem. In this case, repeat again from step 1).
- 7) If there is no leakage, continue evacuation for an additional 20 to 30 minutes.
- 8) Close all valves, and stop the vacuum pump.
- 9) Follow the can tap operation manual, and attach the refrigerant can.

- 13) Loosen the center hose connection on the manifold gauge for a few seconds (if there is a purge valve on the manifold gauge push this instead) to allow the air in the center manifold hose to escape using the refrigerant pressure.

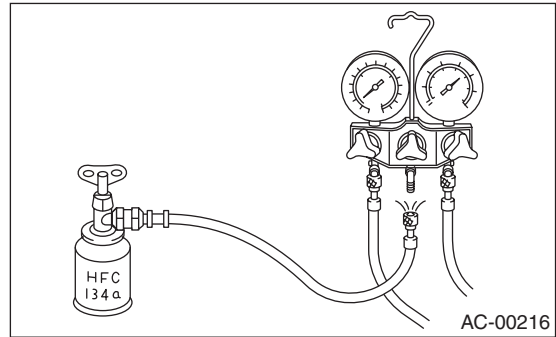

- 14) Open the high pressure side and low pressure side valves of the manifold gauge to fill with refrigerant.

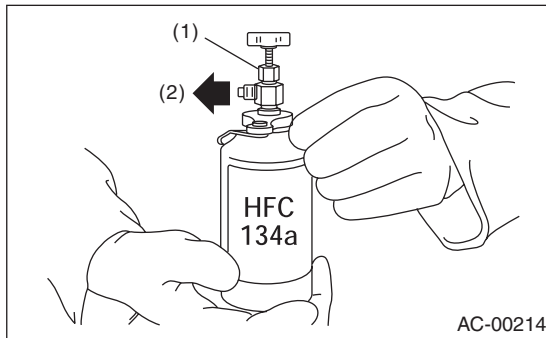

- (1) Tap valve
- (2) To the center manifold hose

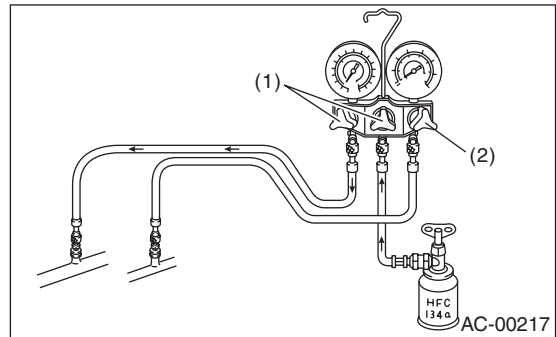

- (1) Open
- (2) Open

- 10) Disconnect the center manifold hose from the vacuum pump, and connect the hose to the tap valve.
- 11) When a 13.6 kg (30 lb) refrigerant container is used, measure the amount of refrigerant with a refrigerant charging scale, and connect with the center manifold hose.

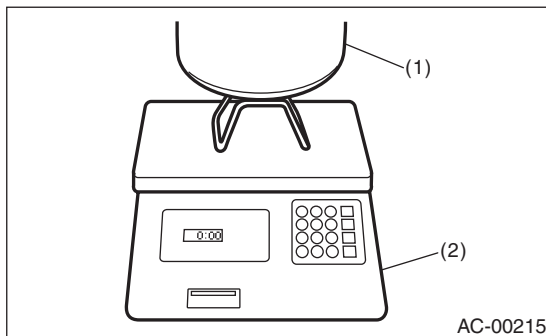

- (1) Refrigerant can (HFC-134a)
- (2) Weight scale

- 12) Open the valve on the HFC-134a source.

CAUTION:

When filling with the engine running, do not open the high pressure side valve. Always fill from the low pressure side.

- 15) When the gauge needle indicates approximately 200 kPa (1,500 mmHg, 59.1 inHg), close all valves.
- 16) Using a leak tester, check for refrigerant leaks in the system.
- 17) After checking that there is no refrigerant leaks, fill with refrigerant up to the specified amount.
- 18) If the HFC-134a supply container becomes empty, close all valves, and close the can tap valve to replace the empty container. After replacing with a new HFC-134a supply container, perform air purge, and resume the filling operation.
- 19) If the refrigerant filling efficiency drops, close all valves.
- 20) Check that both the low pressure and high pressure valves are closed. Start the engine with the A/C switch OFF.
- 21) To prevent damage to the compressor, push the A/C switch ON-OFF quickly a few times.

Refrigerant Charging Procedure

HVAC SYSTEM (HEATER, VENTILATOR AND A/C)

Brought to you by Eris Studios
NOT FOR RESALE

22) Set up the vehicle to the following status:

CAUTION:

When filling with the engine running, do not open the high pressure side valve.

Always fill from the low pressure side valve.

- A/C switch ON
- Engine running at 1,500 rpm
- Blower speed setting to "HI"
- Temperature setting to "MAX COOL"
- Air inlet setting to "RECIRC"
- Window open

23) Open the low pressure side valve and fill with refrigerant up to the specified amount.

24) After filling with refrigerant, close all valves and disconnect the hose from the service port.

25) Attach the cap of the service port.

Refrigerant Leak Check

HVAC SYSTEM (HEATER, VENTILATOR AND A/C)

Brought to you by Eris Studios
NOT FOR SALE

5. Refrigerant Leak Check

A: INSPECTION

1) Operate the A/C system for approx. 10 minutes, and check that the high-side pressure shows at least 690 kPa (7.03 kgf/cm², 100 psi). Then stop the engine to start the leak test.

2) Starting from the connection between high-pressure pipe and evaporator, check the system for leaks along the high-pressure side through the compressor. The following items must be checked thoroughly.

3) Check the joint and seam between pressure switch (triple pressure switch) and high-pressure pipe.

4) Check the connections between condenser and pipes, and welded joints on the condenser.

The leak tester may detect the oil on the condenser fins as a leak.

5) Check the joint between compressor and hoses.

6) Check the machined area of the compressor and other joints on the compressor.

7) Check the compressor shaft seal at the area near the center of compressor clutch pulley.

Shaft seals may show a slight amount of leakage, about 3 g (0.1 oz) per year. This is not a problem.

8) Starting from the connection between low-pressure pipe and evaporator, check the system for leakage along the low-pressure side through the compressor. The following items must be checked thoroughly.

- Connection between 2 parts
- Connection between pipe and plate

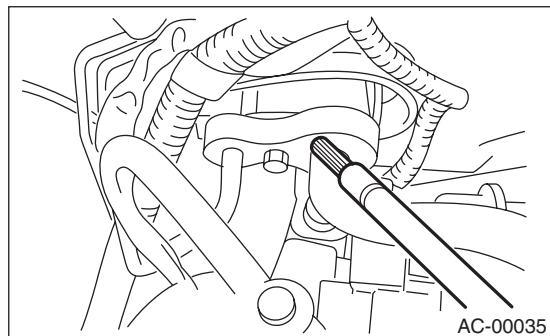

9) Visually check the rubber area of the flexible hose for cracks.

Check the entire length of the flexible hose, especially the connection with the metal hose end.

CAUTION:

Carefully check the external surface of hoses and tubes at approx. 25 mm (0.98 in) per second.

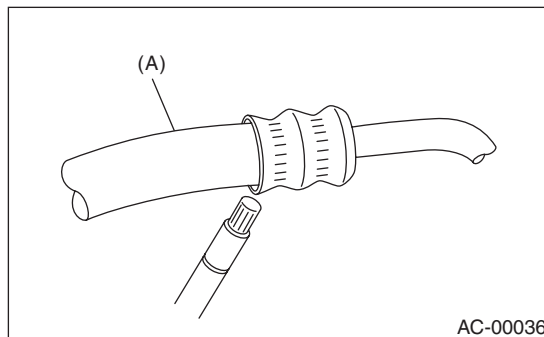

(A) Flexible hose

10) Disconnect the drain hose from the heater case, and check the hose end for at least 10 seconds.

After the test is finished, reconnect the drain hose.

11) Turn the ignition key to the ON position, and run the blower at high speed for approx. 1 minute. Stop the blower and check the ventilation grille on the instrument panel. While moving the tester closer to the grille, run the blower for 1 or 2 seconds, then stop it. Check the grille at that position for at least 10 seconds.

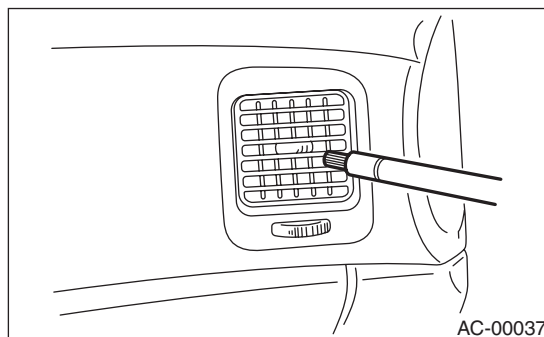

12) Check the valve in the service port.

13) Visually check the rubber seal in the service port cap.

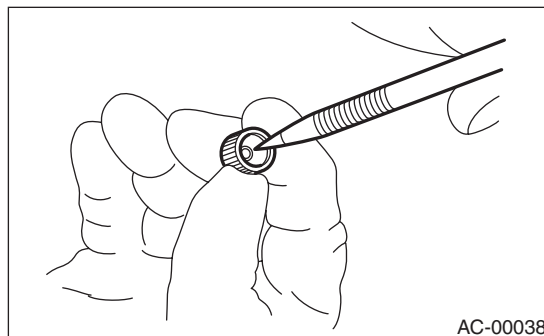

6. Compressor Oil

A: PROCEDURE

NOTE:

Before making repairs, perform the oil return operation to return the compressor oil in circulation with the refrigerant to the compressor.

- 1) Increase the engine to 1,500 rpm.
- 2) Turn the A/C switch to ON.
- 3) Turn the temperature control switch to MAX COOL.
- 4) Put in RECIRC position.
- 5) Turn the blower control switch to HI.
- 6) Leave in this condition for 10 minutes.

B: REPLACEMENT

NOTE:

- If a component has been replaced, add an appropriate amount of compressor oil (same as the amount of remaining oil in removed component).
- When replacing the compressor, the new compressor will already have the specified amount of oil in it. Adjust the oil amount (so that the amount remains the same as that of the removed compressor) and install the new compressor.
- Since the hygroscopicity of compressor oil is high, perform this series of works quickly.

Blower Motor Unit Assembly

HVAC SYSTEM (HEATER, VENTILATOR AND A/C)

Brought to you by Eris Studios
NOT FOR SALE

7. Blower Motor Unit Assembly

A: REMOVAL

- 1) Disconnect the ground cable from the battery.
- 2) Remove the instrument panel lower. <Ref. to EI-46, INSTRUMENT PANEL LOWER, REMOVAL, Center Console.>
- 3) Remove the protect cover of ECM.

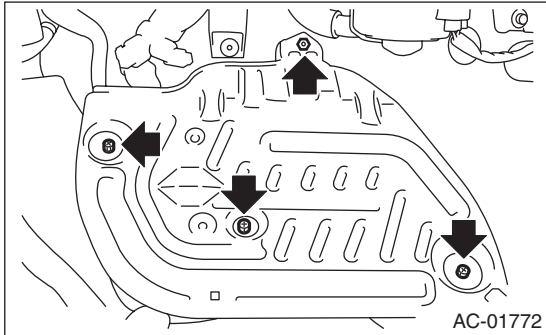

- 4) Disconnect the connectors of the intake door actuator and blower motor.
- 5) Remove the relay holder.
- 6) Loosen the bolt and nut to remove blower motor unit assembly.

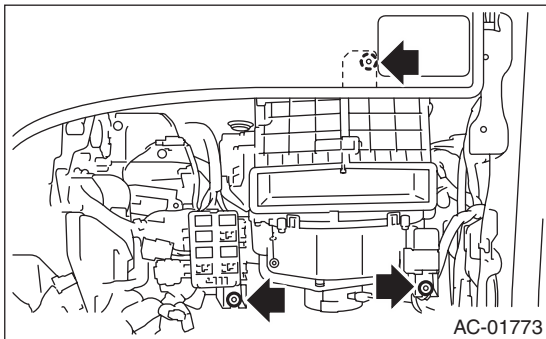

B: INSTALLATION

Install in the reverse order of removal.

Tightening torque:

Refer to “COMPONENT” of “General Description”. <Ref. to AC-4, HEATER COOLING UNIT, COMPONENT, General Description.>
<Ref. to AC-5, BLOWER MOTOR UNIT, COMPONENT, General Description.>

Blower Motor

HVAC SYSTEM (HEATER, VENTILATOR AND A/C)

Brought to you by Eris Studios
NOT FOR RESALE

8. Blower Motor

A: REMOVAL

- 1) Disconnect the battery ground cable from the battery.
- 2) Disconnect the connector of the blower motor.
- 3) Turn up the floor mat near the blower motor.
- 4) Loosen the screw to remove the blower motor.

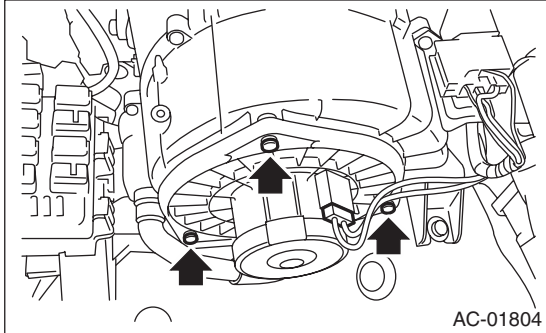

B: INSTALLATION

Install in the reverse order of removal.

C: INSPECTION

Connect the battery positive (+) terminal to terminal No. 2 of blower motor connector, and negative (-) terminal to terminal No. 1. Check the blower motor for smooth rotation.

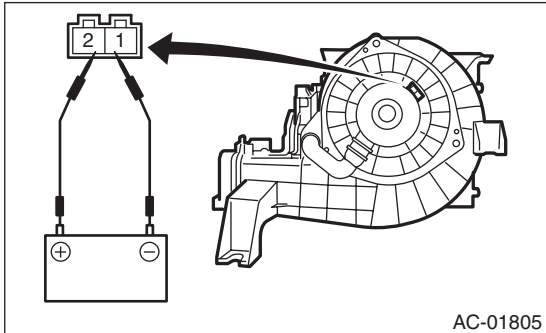

Power Transistor (Auto A/C Model)

HVAC SYSTEM (HEATER, VENTILATOR AND A/C)

Brought to you by Eris Studios
NOT FOR SALE

9. Power Transistor (Auto A/C Model)

A: REMOVAL

- 1) Remove the instrument panel lower. <Ref. to EI-46, INSTRUMENT PANEL LOWER, REMOVAL, Center Console.>
- 2) Disconnect the power transistor connector.
- 3) Remove the two screws and remove the power transistor.

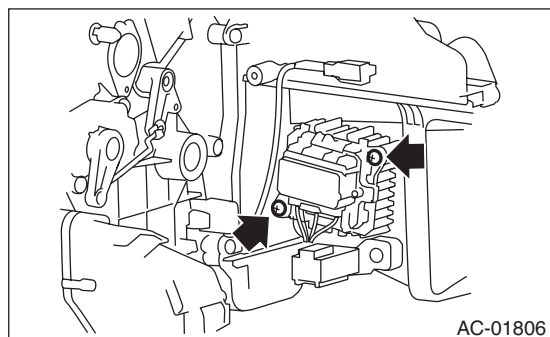

B: INSTALLATION

Install in the reverse order of removal.

Heater Core

HVAC SYSTEM (HEATER, VENTILATOR AND A/C)

Brought to you by Eris Studios
NOT FOR RESALE

10.Heater Core

A: REMOVAL

- 1) Remove the heater and cooling unit. <Ref. to AC-28, REMOVAL, Heater and Cooling Unit.>
- 2) Remove the screws and detach the heater pipe cover.

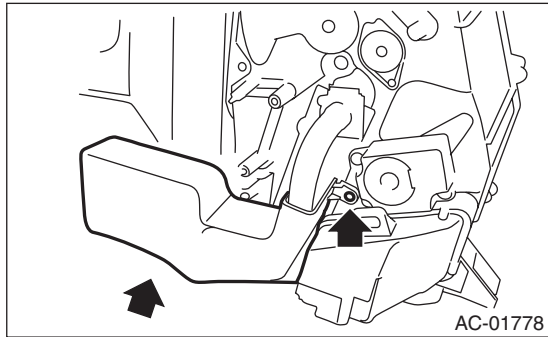

- 3) Remove the screws and detach the clamp.

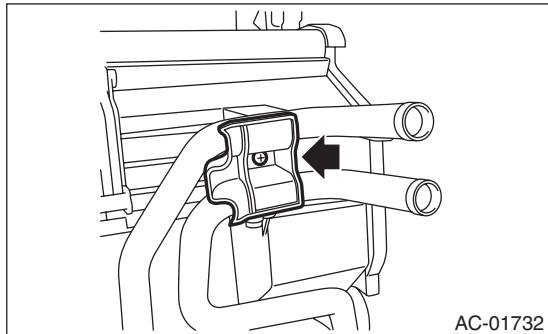

- 4) Remove the pipe clamp and detach the pipe.

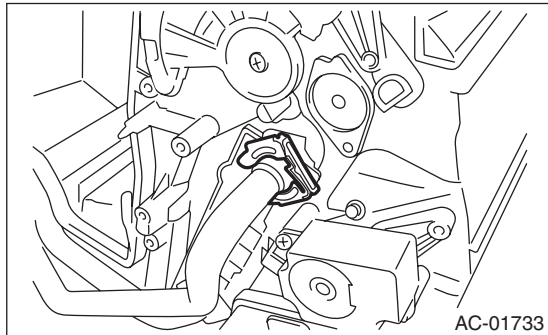

- 5) Remove the heater core cover.

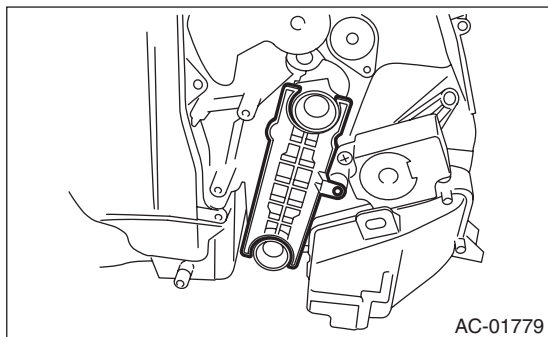

- 6) Remove the heater core.

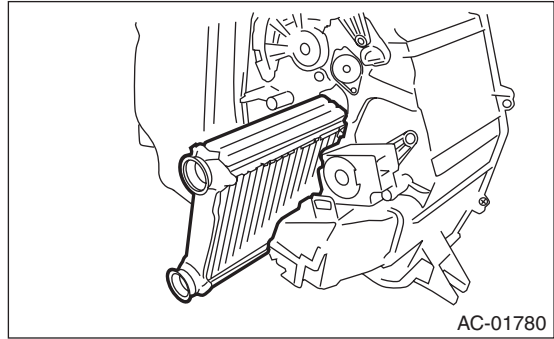

B: INSTALLATION

Install in the reverse order of removal.

CAUTION:

Replace O-rings and pipe clamps with new parts and install securely.

11. Control Unit (Auto A/C Model)

A: REMOVAL

- 1) Disconnect the battery ground cable from the battery.
- 2) Remove the ornament panel. <Ref. to EI-45, ORNAMENT PANEL, REMOVAL, Center Console.>
- 3) Remove the screw and claw and disconnect the connector to detach the control unit from the ornament panel RH.

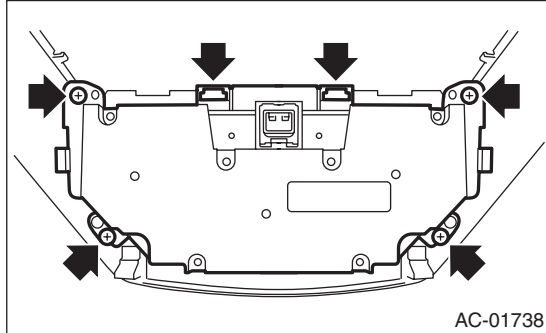

B: INSTALLATION

Install in the reverse order of removal.

12. Compressor

A: INSPECTION

1. MAGNETIC CLUTCH CLEARANCE

Check the clearance of the entire circumference around the drive plate and pulley.

Standard:

0.3 — 0.6 mm (0.0118 — 0.0236 in)

2. MAGNETIC CLUTCH OPERATION

- 1) Disconnect the compressor connector.
 - 2) Connect the battery positive (+) terminal to the terminal of the compressor connector.
 - 3) Check the magnet clutch engagement.
- If there is a malfunction, replace the compressor.

B: REMOVAL

- 1) Perform compressor oil return operation. <Ref. to AC-20, PROCEDURE, Compressor Oil.>
- 2) Turn the A/C switch to OFF and stop the engine.
- 3) Using the refrigerant recovery system, drain the refrigerant. <Ref. to AC-15, PROCEDURE, Refrigerant Recovery Procedure.>
- 4) Disconnect the ground cable from the battery.
- 5) Remove the V-belts. <Ref. to ME(STI)-38, REMOVAL, V-belt.>
- 6) Remove the generator. <Ref. to SC(STI)-13, REMOVAL, Generator.>
- 7) Remove the bolt and remove the low-pressure hose and high-pressure hose.

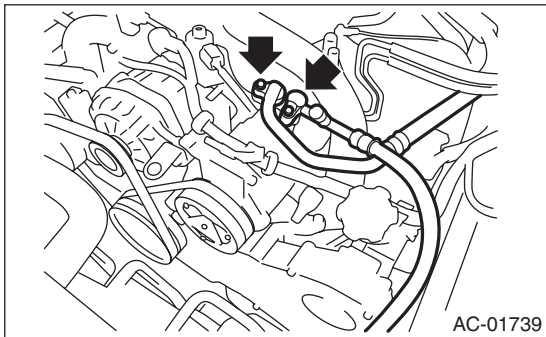

- 8) Disconnect the compressor harness from the body harness.

- 9) Remove the bolts and remove the compressor bracket.

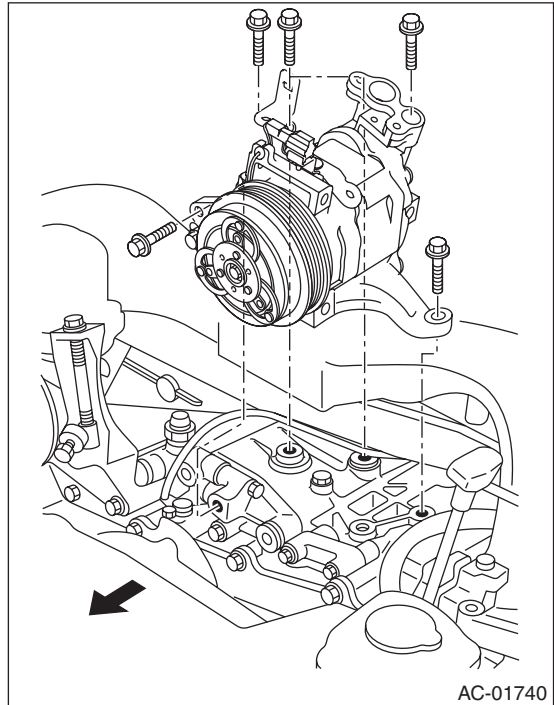

- 10) Remove the bolts, then remove the bracket from the compressor.

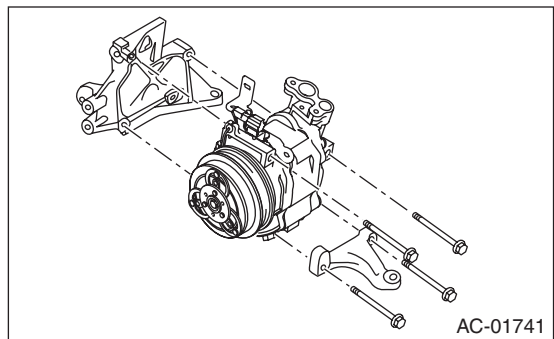

C: INSTALLATION

- 1) Install in the reverse order of removal.
- 2) Replace the O-rings on low-/high-pressure hoses with new parts, then apply compressor oil.
- 3) After replacing the compressor, adjust the amount of compressor oil. <Ref. to AC-20, PROCEDURE, Compressor Oil.>
- 4) Charge refrigerant. <Ref. to AC-16, PROCEDURE, Refrigerant Charging Procedure.>

Tightening torque:

Refer to “COMPONENT” of “General Description”. <Ref. to AC-7, AIR CONDITIONING UNIT, COMPONENT, General Description.>
<Ref. to AC-8, COMPRESSOR, COMPONENT, General Description.>

Condenser

HVAC SYSTEM (HEATER, VENTILATOR AND A/C)

Brought to you by Eris Studios
NOT FOR SALE

13. Condenser

A: REMOVAL

- 1) Using the refrigerant recovery system, drain the refrigerant. <Ref. to AC-15, PROCEDURE, Refrigerant Recovery Procedure.>
- 2) Disconnect the ground cable from the battery.
- 3) Disconnect the high pressure hose and pipe from the condenser.

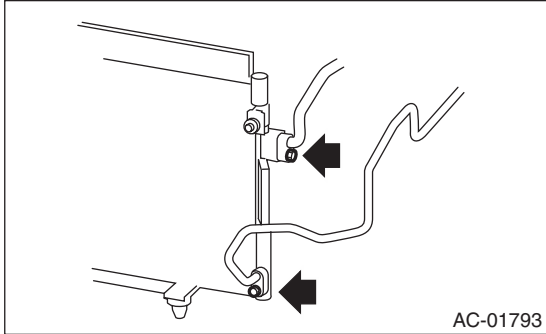

- 4) Remove the radiator brackets.

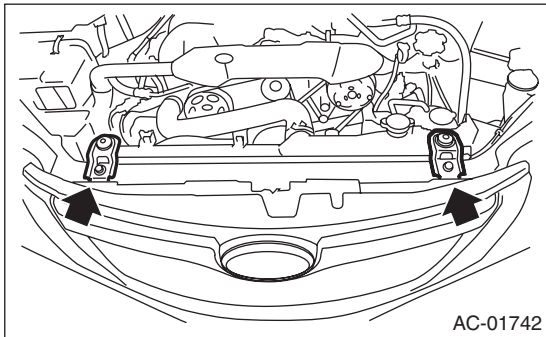

- 5) Remove the front bumper. <Ref. to EI-26, REMOVAL, Front Bumper.>
- 6) Remove two bolts. While lifting the condenser, pull out through space between the radiator and the radiator panel.

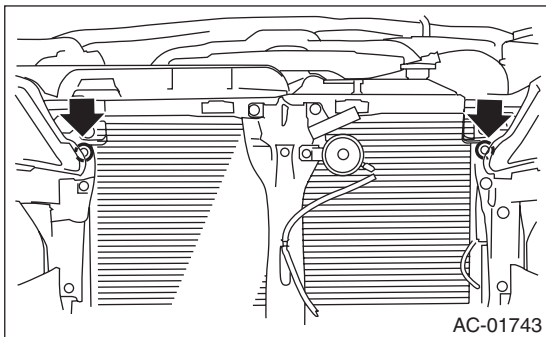

CAUTION:

- Be careful not to damage the condenser fins. If a damaged fin is found, repair it using a thin screwdriver.
- When replacing the condenser, add an appropriate amount of compressor oil to the compressor. <Ref. to AC-20, REPLACEMENT, Compressor Oil.>

B: INSTALLATION

- 1) Install in the reverse order of removal.

CAUTION:

Replace the O-rings on hoses or pipes with new parts, and then apply compressor oil. Confirm that lower guide (A) of condenser fits into holes on radiator panel.

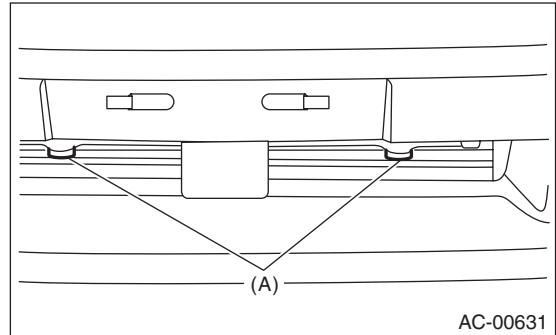

- 2) Charge with refrigerant. <Ref. to AC-16, PROCEDURE, Refrigerant Charging Procedure.>

Tightening torque:

Refer to "COMPONENT" of "General Description". <Ref. to AC-7, AIR CONDITIONING UNIT, COMPONENT, General Description.> <Ref. to CO(STI)-5, RADIATOR AND RADIATOR FAN, COMPONENT, General Description.>

C: INSPECTION

- 1) Check to see that the condenser fins are not clogged with debris or insects. Blow with compressed air or flush fins with water as needed.
- 2) Inspect for oil leakage from the condenser. If a failure is found, replace the condenser with a new part.

14. Heater and Cooling Unit

A: REMOVAL

- 1) Disconnect the ground cable from the battery.
- 2) Using the refrigerant recovery system, drain the refrigerant. <Ref. to AC-15, PROCEDURE, Refrigerant Recovery Procedure.>
- 3) Drain coolant from the radiator.
- 4) Remove the bolts securing expansion valve and pipe in engine compartment. Release the heater hose clamps in engine compartment to remove the hoses.

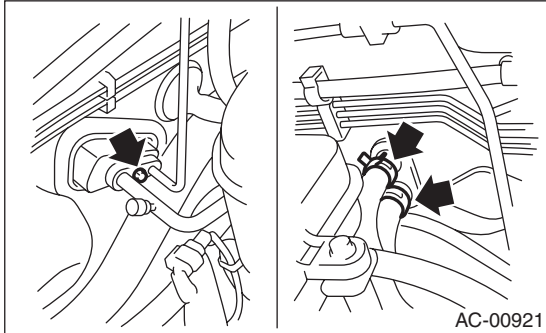

- 5) Remove the instrument panel. <Ref. to EI-47, REMOVAL, Instrument Panel Assembly.>
- 6) Remove the blower motor unit assembly. <Ref. to AC-21, REMOVAL, Blower Motor Unit Assembly.>
- 7) Disconnect the connectors of the actuator, thermo sensor, and power transistor.
- 8) Remove the bolt and nuts and remove the heater and cooling unit.

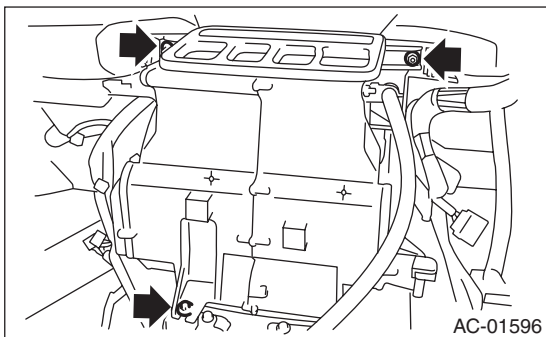

B: INSTALLATION

- 1) Install in the reverse order of removal.
- 2) Charge refrigerant. <Ref. to AC-16, PROCEDURE, Refrigerant Charging Procedure.>

Tightening torque:

Refer to “COMPONENT” of “General Description”. <Ref. to AC-4, HEATER COOLING UNIT, COMPONENT, General Description.>

Evaporator

HVAC SYSTEM (HEATER, VENTILATOR AND A/C)

Brought to you by Eris Studios
NOT FOR SALE

15. Evaporator

A: REMOVAL

- 1) Using the refrigerant recovery system, discharge refrigerant. <Ref. to AC-15, PROCEDURE, Refrigerant Recovery Procedure.>
- 2) Remove the heater and cooling unit. <Ref. to AC-28, REMOVAL, Heater and Cooling Unit.>
- 3) Remove the screws and detach the cover.

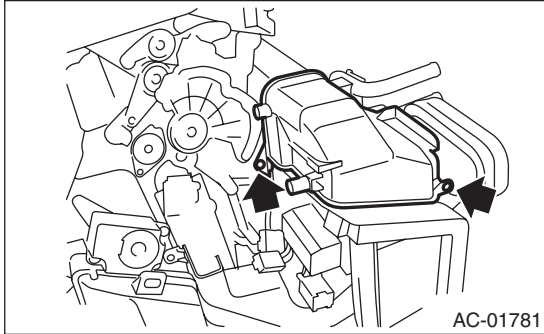

- 4) Remove the bolt and detach the pipe.

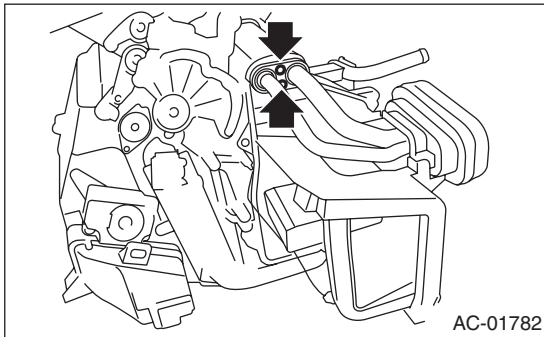

- 5) Remove the screws and detach the cover.

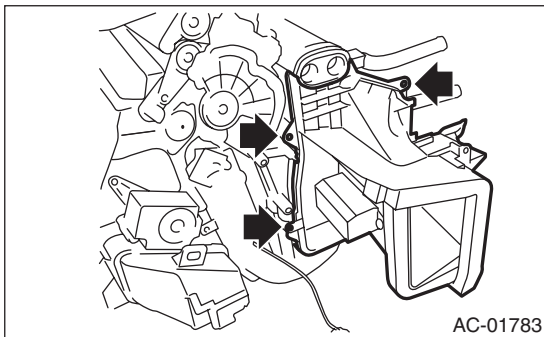

- 6) Remove the evaporator.

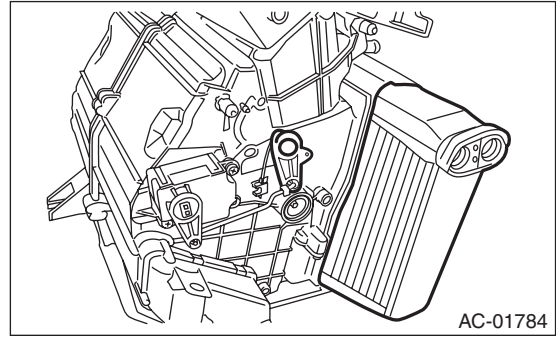

CAUTION:

If the evaporator is replaced, add an appropriate amount of compressor oil to evaporator. <Ref. to AC-20, REPLACEMENT, Compressor Oil.>

B: INSTALLATION

Install in the reverse order of removal.

CAUTION:

- Make sure that the water seal gasket on the cover attachment area is securely attached.
- Install the sensor at the position shown in the figure below.

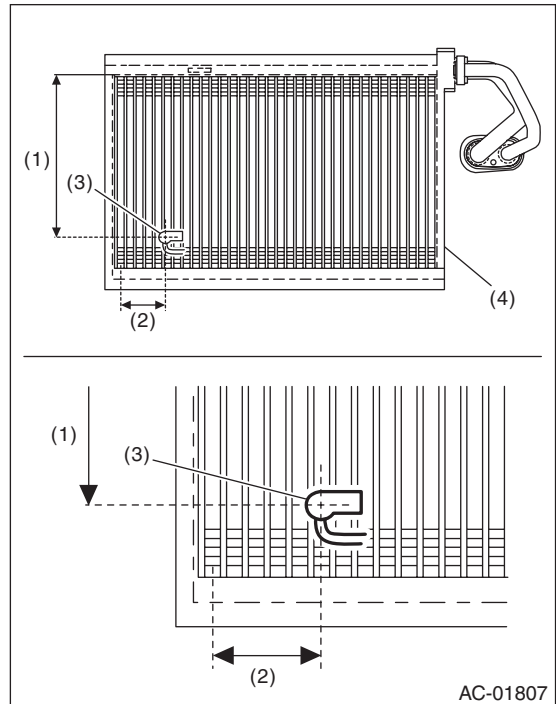

- (1) 148 mm (5.83 in) from the upper end of the fin
- (2) The 6th column fin from the left end
- (3) Sensor
- (4) Evaporator

16.Hose and Tube

A: REMOVAL

CAUTION:

- When disconnecting/connecting hoses, do not apply an excessive force to them. After installing, check that no torsion or excessive tension applied to the hoses.
 - Seal the disconnected hose with a plug or vinyl tape to prevent foreign matter from entering.
- 1) Disconnect the ground cable from the battery.
 - 2) Using the refrigerant recovery system, discharge refrigerant. <Ref. to AC-15, PROCEDURE, Refrigerant Recovery Procedure.>
 - 3) Remove the evaporator unit mounting bolt (A) and low-pressure hose bracket bolt (B).
 - 4) Remove the low-pressure hose attaching bolts (C).
 - 5) Disconnect the low-pressure hose from evaporator unit.
 - 6) Disconnect the low-pressure hose from compressor.
 - 7) Remove the low-pressure hose from vehicle.
 - 8) Remove the high-pressure hose attaching bolt (D).
 - 9) Disconnect the high-pressure hose from compressor.
 - 10) Disconnect the high-pressure hose from condenser.
 - 11) Remove the high-pressure hose from vehicle.
 - 12) Remove the high-pressure tube attaching bolt (E).
 - 13) Remove the high-pressure tube from vehicle.

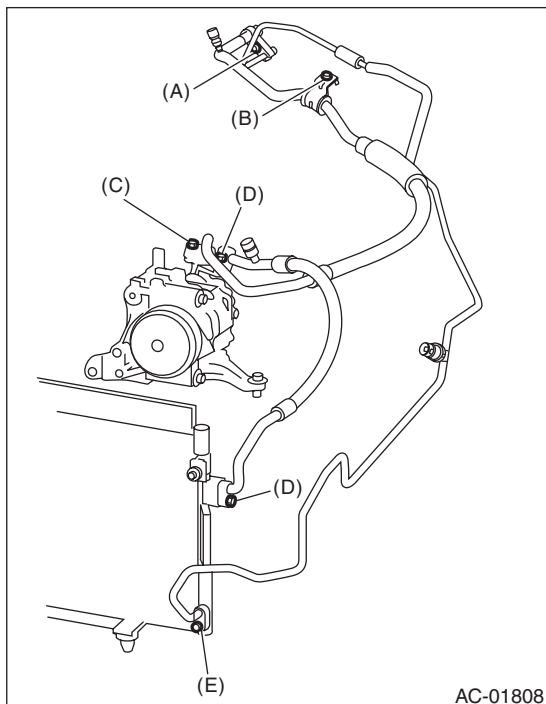

B: INSTALLATION

CAUTION:

- When disconnecting or connecting the hoses, do not apply excessive force. After installing, check that no torsion or excessive tension applied to the hoses.
 - Seal the disconnected hose with a plug or vinyl tape to prevent foreign matter from entering.
- 1) Install in the reverse order of removal.
 - 2) Charge refrigerant. <Ref. to AC-16, PROCEDURE, Refrigerant Charging Procedure.>

Tightening torque:

Refer to “COMPONENT” of “General Description”. <Ref. to AC-7, AIR CONDITIONING UNIT, COMPONENT, General Description.>

C: INSPECTION

Check the hoses for cracks, damage and expansion. If any fault is found, replace with new parts.

Relay and Fuse

HVAC SYSTEM (HEATER, VENTILATOR AND A/C)

Brought to you by Chris Studios
NOT FOR SALE

17. Relay and Fuse

A: LOCATION

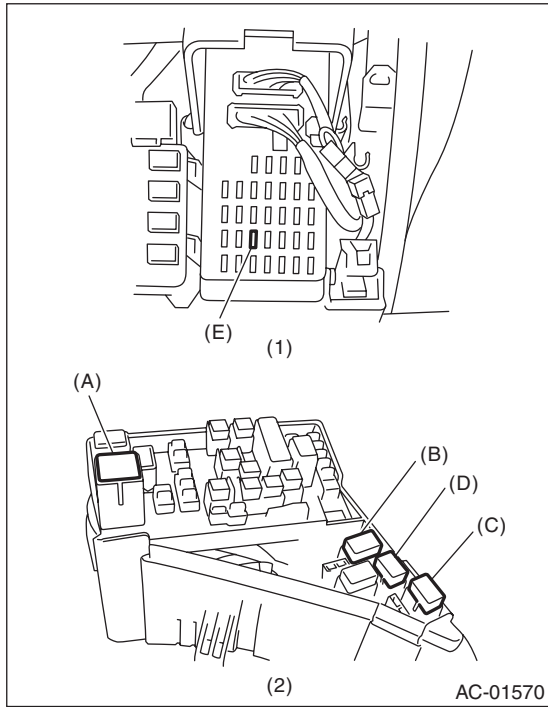

- (1) Joint box
- (2) Main fuse box

Main fan relay 1	(A)
Main fan relay 2	(B)
Sub fan relay	(C)
A/C relay	(D)
A/C Fuse	(E)

B: INSPECTION

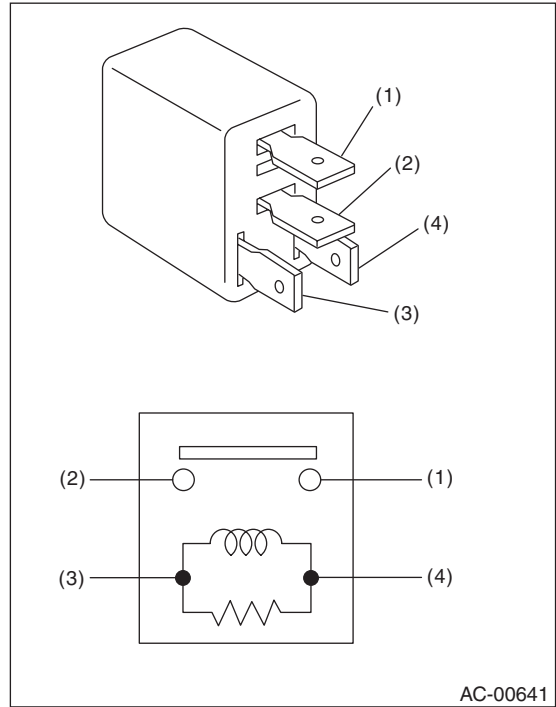

- (3) — (4): Continuity exists
- (1) — (2): Continuity does not exist

While applying battery voltage to the terminal between (3) and (4), check for continuity between (1) and (2).

If no continuity exists, replace the relay with a new part.

Pressure Switch (Triple Pressure Switch)

HVAC SYSTEM (HEATER, VENTILATOR AND A/C)

Brought to you by Eris Studios
NOT FOR RESALE

18. Pressure Switch (Triple Pressure Switch)

A: INSPECTION

- 1) Connect the manifold gauge to the service valve on the high-pressure side.
- 2) Disconnect the pressure switch harness connector.
- 3) Start the air conditioner, and check the operating pressure of switch by turning the compressor (magnet clutch) to ON/OFF. Operation of each switch is as follows.

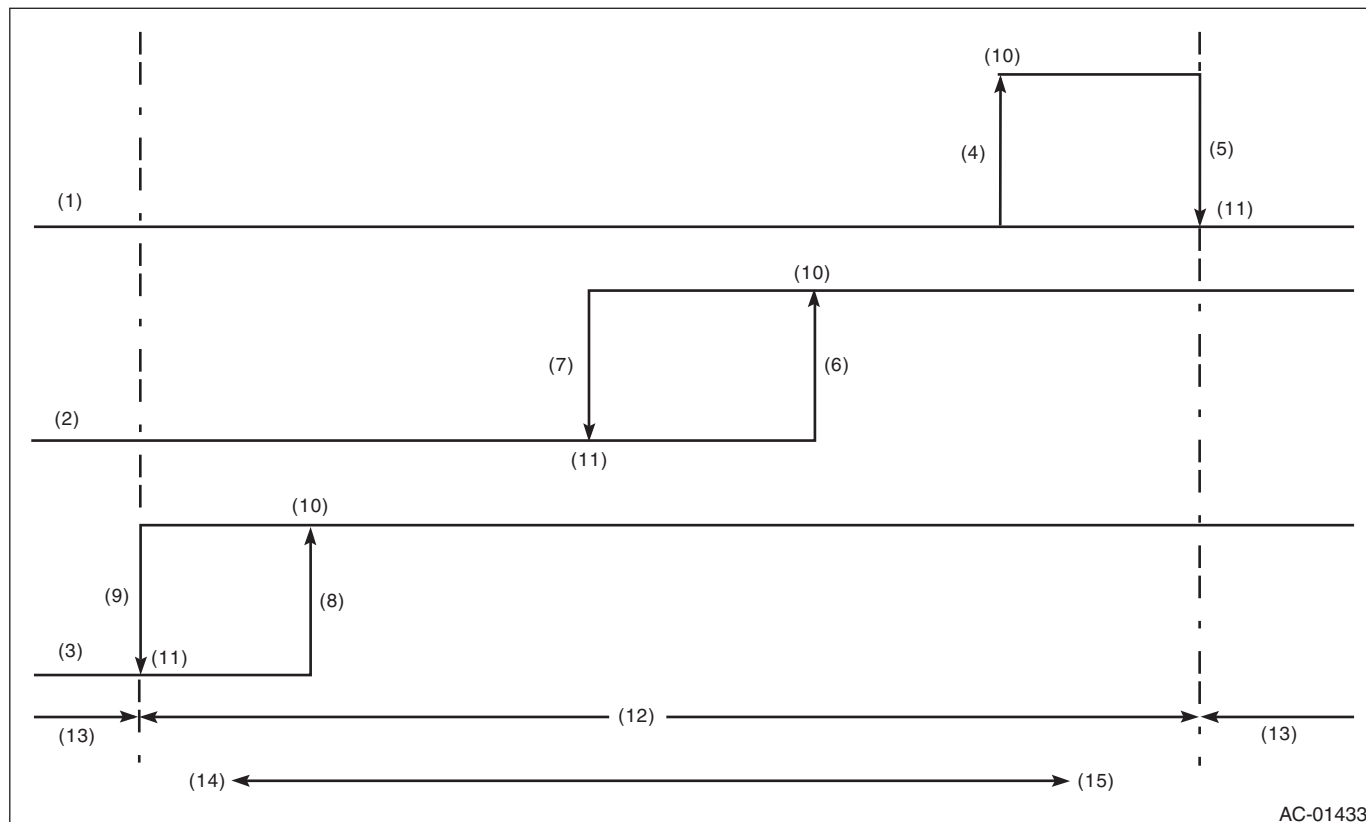

AC-01433

(1) High pressure switch	(7) 1,470±120 kPa	(10) ON
(2) Middle pressure switch	(14.99±1.22 kg/cm ² ,	(11) OFF
(3) Low pressure switch	213.15±17.4 psi)	(12) Operative range of compressor
(4) 2,350±200 kPa	(8) 206±30 kPa	(13) Inoperative range of compressor
(24.00±2.04 kg/cm ² , 340.7±29.0 psi)	(2.10±0.31 kg/cm ² , 29.9±4.3 psi)	(14) Low pressure
(5) 2,940±200 kPa	(9) 177±25 kPa	(15) High pressure
(29.98±2.04 kg/cm ² , 426.3±29.0 psi)	(1.80±0.25 kg/cm ² , 25.7±3.6 psi)	
(6) 1,770±100 kPa		
(18.05±1.02 kg/cm ² ,		
256.65±14.5 psi)		

NOTE:

- High pressure switch turns the compressor (magnet clutch) to OFF when the refrigerant pressure becomes extremely high to prevent the evaporator, air conditioner piping and expansion valve from getting damaged or frozen, etc.
- Middle pressure switch effectively controls the radiator fan output by judging high load/low load in normal range.
- Low pressure switch turns the compressor (magnet clutch) to OFF, judging as low refrigerant level when the refrigerant pressure becomes extremely low, to prevent the possible seizure if the compressor rotates.

Ambient Sensor (Auto A/C Model)

HVAC SYSTEM (HEATER, VENTILATOR AND A/C)

Brought to you by Eris Studios
NOT FOR SALE

19. Ambient Sensor (Auto A/C Model)

A: REMOVAL

- 1) Disconnect the ground cable from the battery.
- 2) Disconnect the ambient sensor connector.
- 3) Remove the ambient sensor from the radiator lower panel.

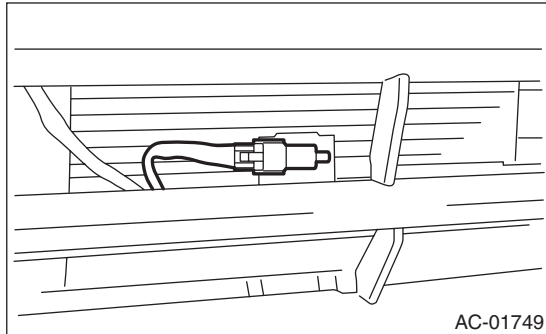

B: INSTALLATION

Install in the reverse order of removal.

C: INSPECTION

<Ref. to AC(diag)-29, AMBIENT SENSOR, Diagnostic Procedure for Sensors.>

Sunload Sensor (Auto A/C Model)

HVAC SYSTEM (HEATER, VENTILATOR AND A/C)

Brought to you by Eris Studios
NOT FOR RESALE

20. Sunload Sensor (Auto A/C Model)

A: REMOVAL

- 1) Disconnect the ground cable from the battery.
- 2) Remove the audio. <Ref. to ET-6, REMOVAL, Audio.>
- 3) Push out the sunlight sensor from the back side of the instrument panel.

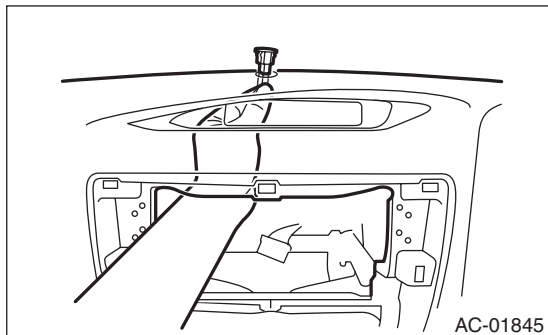

- 4) Disconnect the connector, and remove the sunlight sensor.

CAUTION:

Be careful not to damage the interior trims when removing the sensor.

B: INSTALLATION

Install in the reverse order of removal.

C: INSPECTION

<Ref. to AC(diag)-35, SUNLOAD SENSOR, Diagnostic Procedure for Sensors.>

In-vehicle Sensor (Auto A/C Model)

HVAC SYSTEM (HEATER, VENTILATOR AND A/C)

Brought to you by Eris Studios
NOT FOR SALE

21. In-vehicle Sensor (Auto A/C Model)

A: REMOVAL

- 1) Disconnect the ground cable from the battery.
- 2) Remove the instrument panel lower. <Ref. to EI-46, INSTRUMENT PANEL LOWER, REMOVAL, Center Console.>
- 3) Disconnect the connector and aspirator hose, remove the screw and remove the in-vehicle sensor from the instrument panel.



CAUTION:

Be careful not to damage the sensors and interior trims when removing.

B: INSTALLATION

Install in the reverse order of removal.

C: INSPECTION

<Ref. to AC(diag)-31, IN-VEHICLE SENSOR, Diagnostic Procedure for Sensors.>

Air Vent Grille

HVAC SYSTEM (HEATER, VENTILATOR AND A/C)

Brought to you by Eris Studios
NOT FOR RESALE

22. Air Vent Grille

A: REMOVAL

1. CENTER GRILLE

- 1) Insert the plastic remover into the slit on the bottom of the center panel, to lift the panel.
- 2) Detach the claw and plastic hook, and remove the center panel.

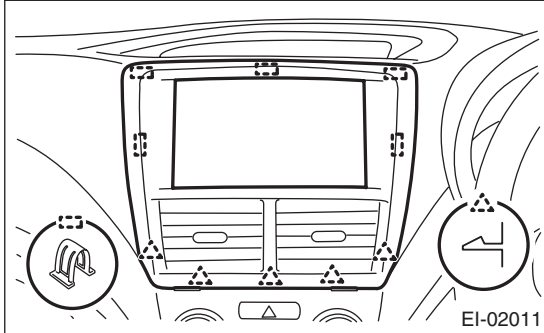

- 3) Remove the air vent center grille from the center panel.

2. SIDE GRILLE

- 1) Remove the ornament panel. <Ref. to EI-45, ORNAMENT PANEL, REMOVAL, Center Console.>
- 2) Remove the claws, and remove the air vent side grille.

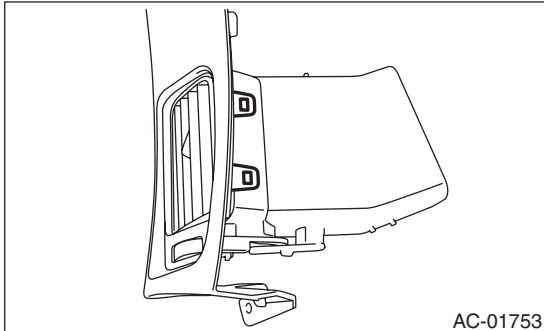

B: INSTALLATION

Install in the reverse order of removal.

C: INSPECTION

- 1) Check that the direction and amount of air can be adjusted smoothly.
- 2) Check that the adjustment can be maintained in each position.

23.Heater Duct

A: REMOVAL

1. REAR HEATER DUCT

- 1) Remove the heater cooling unit. <Ref. to AC-28, REMOVAL, Heater and Cooling Unit.>
- 2) Remove the front seats. <Ref. to SE-6, REMOVAL, Front Seat.>
- 3) Remove the front side sill cover.
- 4) Pull off the floor mat to remove the rear center heater duct (A) and rear heater duct LH, RH (B).

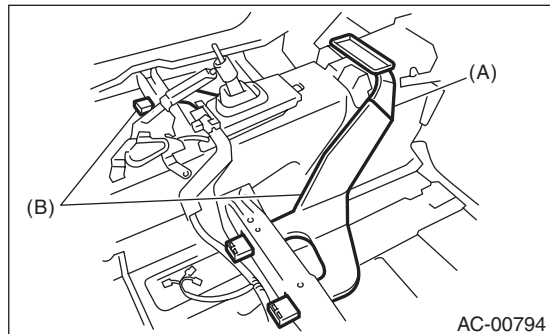

B: INSTALLATION

Install in the reverse order of removal.

Heater Vent Duct

HVAC SYSTEM (HEATER, VENTILATOR AND A/C)

Brought to you by Eris Studios
NOT FOR RESALE

24.Heater Vent Duct

A: REMOVAL

- 1) Remove the instrument panel. <Ref. to EI-47, REMOVAL, Instrument Panel Assembly.>
- 2) Remove the screws, and then remove the heater vent duct.

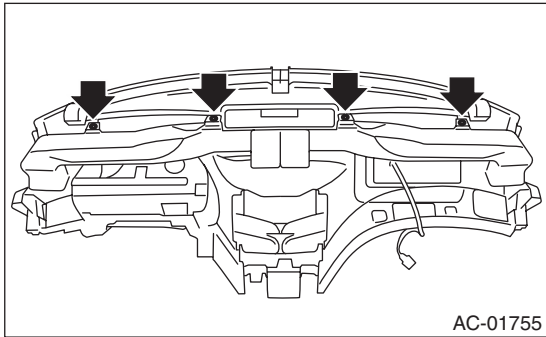

B: INSTALLATION

Install in the reverse order of removal.

25. A/C Filter

A: REPLACEMENT

1) Remove the glove box damper.

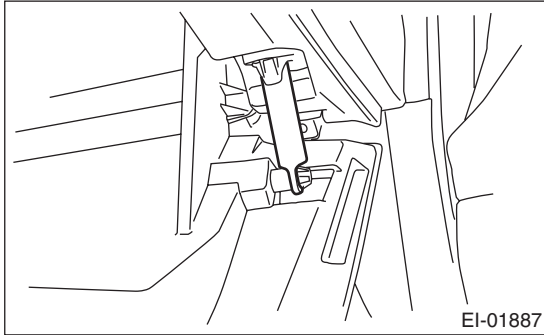

2) Disengage the stopper section and pull the glove box lid to remove it.

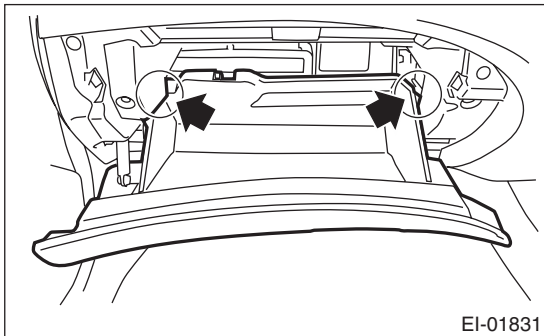

3) Pinch the claw to unlock and remove the A/C filter.

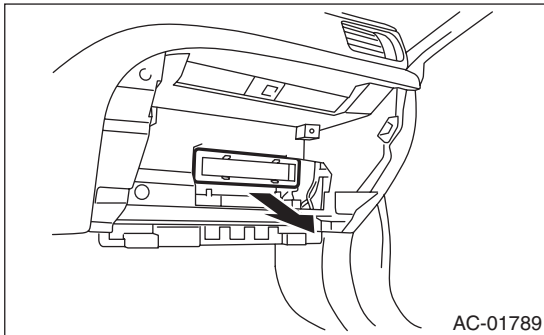

4) Install in the reverse order of removal.

General Diagnostic Table

HVAC SYSTEM (HEATER, VENTILATOR AND A/C)

Brought to you by Eris Studios
NOT FOR RESALE

26. General Diagnostic Table

A: INSPECTION

Symptoms		Repair order
Blower motor	Does not operate.	Fuse
		Blower motor relay
		Blower motor
		Blower switch
		Wiring harness
	Noise	Blower motor
Compressor	Does not operate.	Refrigerant
		Fuse
		Air conditioning relay
		Magnet clutch
		Compressor
		Pressure switch
		A/C switch
		Blower switch
		Wiring harness
	Noise	V-belt
		Magnet clutch
		Compressor
Cold air not emitted.		Refrigerant
		V-belt
		Magnet clutch
		Compressor
		Pressure switch
		Aspirator hose
		Blower fan relay
		Blower motor
		A/C switch
		Blower switch
		Control module
		Expansion valve
		Evaporator
		Air mix actuator
		Wiring harness
		Heater duct
		Heater vent duct
	Warm air not emitted.	
		Aspirator hose
		Air mix actuator
		Blower switch
		Heater core
Temperature of air from vents does not change.		Engine coolant
		Air mix actuator
		Temperature control switch
		Wiring harness
Unable to switch blow vents.		Mode actuator
		Mode switch
		Wiring harness

General Diagnostic Table

HVAC SYSTEM (HEATER, VENTILATOR AND A/C)

Brought to you by Eris Studios
NOT FOR SALE

Symptoms	Repair order
Unable to switch suction vents.	FRESH/RECIRC select switch
	Intake door actuator
	Wiring harness

General Diagnostic Table

HVAC SYSTEM (HEATER, VENTILATOR AND A/C)

Brought to you by Eris Studios
NOT FOR RESALE