

Brought to you by Eris Studios
NOT FOR RESALE

CRUISE CONTROL SYSTEM (DIAGNOSTICS)

Basic Diagnostic Procedure

CRUISE CONTROL SYSTEM (DIAGNOSTICS)

Brought to you by Eris Studios
NOT FOR RESALE

1. Basic Diagnostic Procedure

A: PROCEDURE

	Step	Check	Yes	No
1	CHECK MALFUNCTION INDICATOR LIGHT. Make sure the malfunction indicator light illuminates.	Does the malfunction indicator light illuminate?	Go to step 5.	Go to step 2.
2	CHECK CRUISE INDICATOR LIGHT. Make sure the cruise indicator light blinks.	Does the cruise indicator light blink?	Go to step 5.	Go to step 3.
3	CHECK CRUISE CONTROL MAIN SWITCH OPERATION. Check cruise control main switch operation. (Ensure the cruise indicator light illuminates.)	Is the cruise control main switch turned on? (Does the cruise indicator light illuminate?)	Go to step 4.	Go to phenomenon 1. <Ref. to CC(diag)-9, DIAGNOSTIC PROCEDURE WITH PHENOMENON, Diagnostics with Phenomenon.>
4	CHECK CRUISE CONTROL SET OPERATION. Check the cruise control setting operation.	Can the cruise control be set while driving at 40 km/h (25 MPH) or more?	Go to step 6.	Go to step 5.
5	CHECK DTC. Using the Subaru Select Monitor, read all DTCs.	Is an engine or ABS/VDC related DTC displayed?	Perform the diagnosis according to the engine or ABS/VDC related DTC.	Go to phenomenon 2. <Ref. to CC(diag)-9, DIAGNOSTIC PROCEDURE WITH PHENOMENON, Diagnostics with Phenomenon.>
6	CHECK CANCEL CODE. 1) Perform driving test. 2) Set cruise control and drive the vehicle until the cruise control is deactivated. 3) Using the Subaru Select Monitor, read the cancel codes. NOTE: • Do not turn the ignition switch to OFF after the cruise control is deactivated. • Do not operate the cruise control command switch after the cruise control is deactivated. If the above is performed, the cancel code will be cleared.	Is it possible to read the cancel codes?	Perform the diagnosis according to the cancel code. <Ref. to CC(diag)-13, LIST, List of Cancel Code.>	Go to step 7.
7	CHECK CRUISE SET INDICATOR LIGHT. Make sure the cruise set indicator light illuminates.	Does the cruise set indicator light illuminate?	Go to step 8.	Go to phenomenon 3. <Ref. to CC(diag)-9, DIAGNOSTIC PROCEDURE WITH PHENOMENON, Diagnostics with Phenomenon.>
8	CHECK VEHICLE SPEED IS HELD WITHIN SET SPEED. Make sure the vehicle speed is held within set speed.	Is the vehicle speed kept within setting speed ± 3 km/h (± 2 MPH) ? (Make sure that on a level road.)	Go to step 9.	Go to phenomenon 4. <Ref. to CC(diag)-9, DIAGNOSTIC PROCEDURE WITH PHENOMENON, Diagnostics with Phenomenon.>

Basic Diagnostic Procedure

CRUISE CONTROL SYSTEM (DIAGNOSTICS)

Brought to you by Eris Studios
 NOT FOR SALE

Step	Check	Yes	No
9 CHECK RESUME/ACCEL OPERATION. Check the RESUME/ACCEL switch operation.	Does the vehicle speed increase or return to set speed after RESUME/ACCEL switch has been pressed?	Go to step 10.	Go to phenomenon 5. <Ref. to CC(diag)-9, DIAGNOSTIC PROCEDURE WITH PHENOMENON, Diagnostics with Phenomenon.>
10 CHECK SET/COAST OPERATION. Check the SET/COAST switch operation.	Does the vehicle speed decrease after SET/COAST switch has been pressed?	Go to step 11.	Go to phenomenon 6. <Ref. to CC(diag)-9, DIAGNOSTIC PROCEDURE WITH PHENOMENON, Diagnostics with Phenomenon.>
11 CANCEL OPERATION CHECK. Check the CANCEL switch operation.	Is the cruise control released after CANCEL switch has been pressed?	Go to step 12.	Go to phenomenon 7. <Ref. to CC(diag)-9, DIAGNOSTIC PROCEDURE WITH PHENOMENON, Diagnostics with Phenomenon.>
12 CHECK CRUISE CONTROL RELEASE OPERATION. Check the cruise control release operation.	Is the cruise control released after brake pedal has been depressed?	Go to step 13.	Go to phenomenon 8. <Ref. to CC(diag)-9, DIAGNOSTIC PROCEDURE WITH PHENOMENON, Diagnostics with Phenomenon.>
13 CHECK CRUISE CONTROL RELEASE OPERATION. Check the cruise control release operation.	Is the cruise control released after shifting to the neutral position?	Go to step 14.	Go to phenomenon 9. <Ref. to CC(diag)-9, DIAGNOSTIC PROCEDURE WITH PHENOMENON, Diagnostics with Phenomenon.>
14 CHECK CRUISE CONTROL RELEASE OPERATION. Check the cruise control release operation.	Is the cruise control released after depressing the clutch pedal?	Finish the diagnosis.	Go to phenomenon 10. <Ref. to CC(diag)-9, DIAGNOSTIC PROCEDURE WITH PHENOMENON, Diagnostics with Phenomenon.>

General Description

CRUISE CONTROL SYSTEM (DIAGNOSTICS)

Brought to you by Eris Studios
NOT FOR RESALE

2. General Description

A: CAUTION

Airbag system wiring harness is routed near the cruise control command switch.

CAUTION:

- Airbag system wiring harnesses and connectors are yellow. Do not use electrical test equipment on these circuits.
- Be careful not to damage the airbag system wiring harness when servicing the cruise control command switch. Airbag system wiring harness is routed near the cruise control command switch.

B: PREPARATION TOOL

1. SPECIAL TOOL

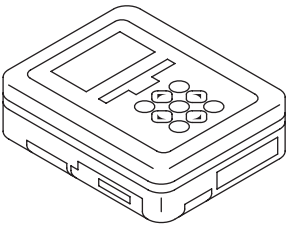
ILLUSTRATION	TOOL NUMBER	DESCRIPTION	REMARKS
 ST1B021XU0	1B021XU0	SUBARU SELECT MONITOR III KIT	Used for troubleshooting the electrical system.

2. GENERAL TOOL

TOOL NAME	REMARKS
Circuit tester	Used for measuring resistance, voltage and current.

C: INSPECTION

Measure the battery voltage and specific gravity of electrolyte.

Standard voltage:

12 V or more

Specific gravity:

1.260 or more

Electrical Component Location

CRUISE CONTROL SYSTEM (DIAGNOSTICS)

Brought to you by Eris Studios
NOT FOR SALE

3. Electrical Component Location

A: LOCATION

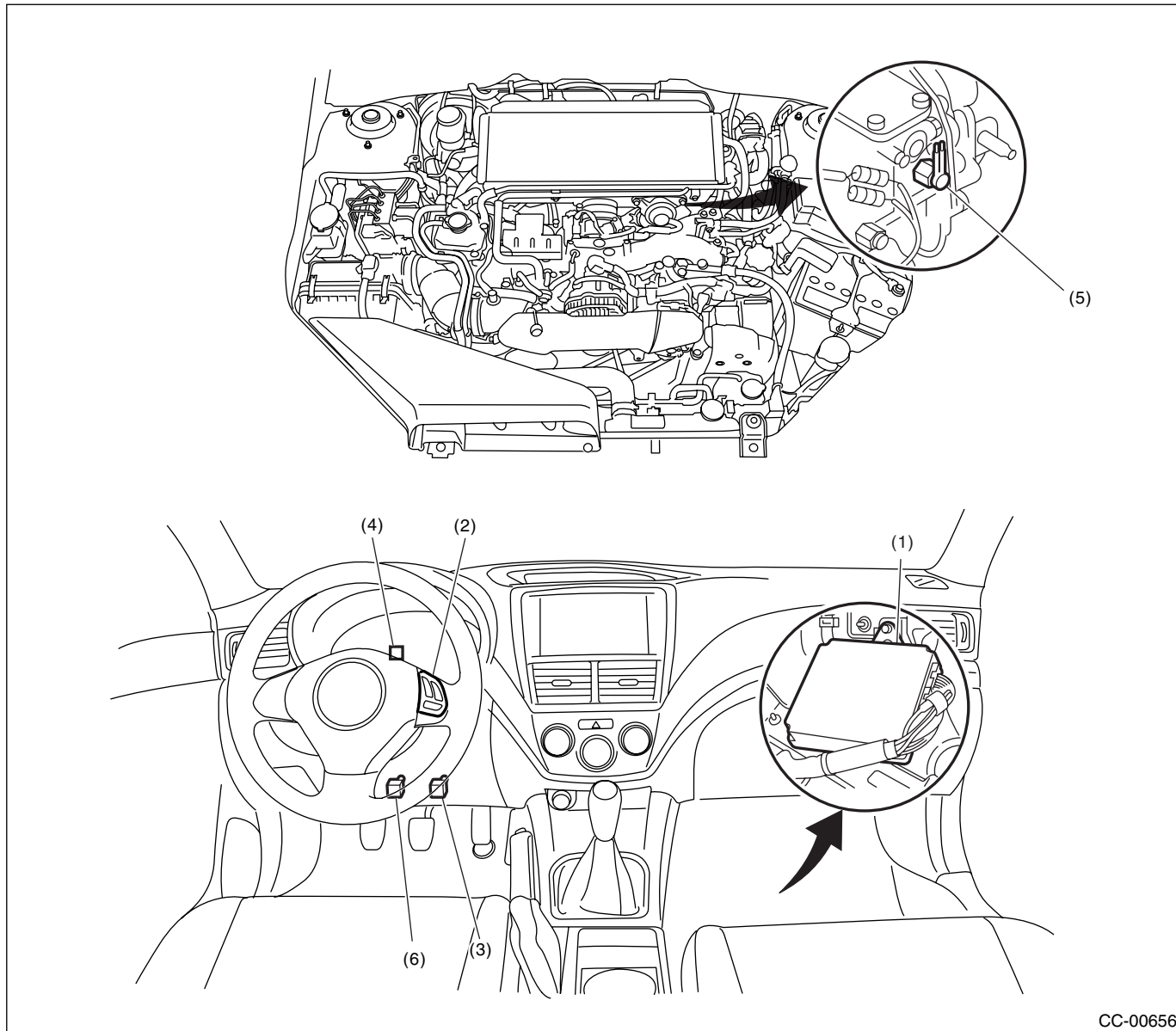

CC-00656

- | | | |
|-----------------------------------|---|--|
| (1) Engine control module (ECM) | (4) Cruise indicator light and cruise set indicator light | (5) Neutral position switch (MT model) |
| (2) Cruise control command switch | | (6) Clutch switch (MT model) |
| (3) Stop light & brake switch | | |

Engine Control Module (ECM) I/O Signal

CRUISE CONTROL SYSTEM (DIAGNOSTICS)

Brought to you by Eris Studios
NOT FOR RESALE

4. Engine Control Module (ECM) I/O Signal

A: ELECTRICAL SPECIFICATION

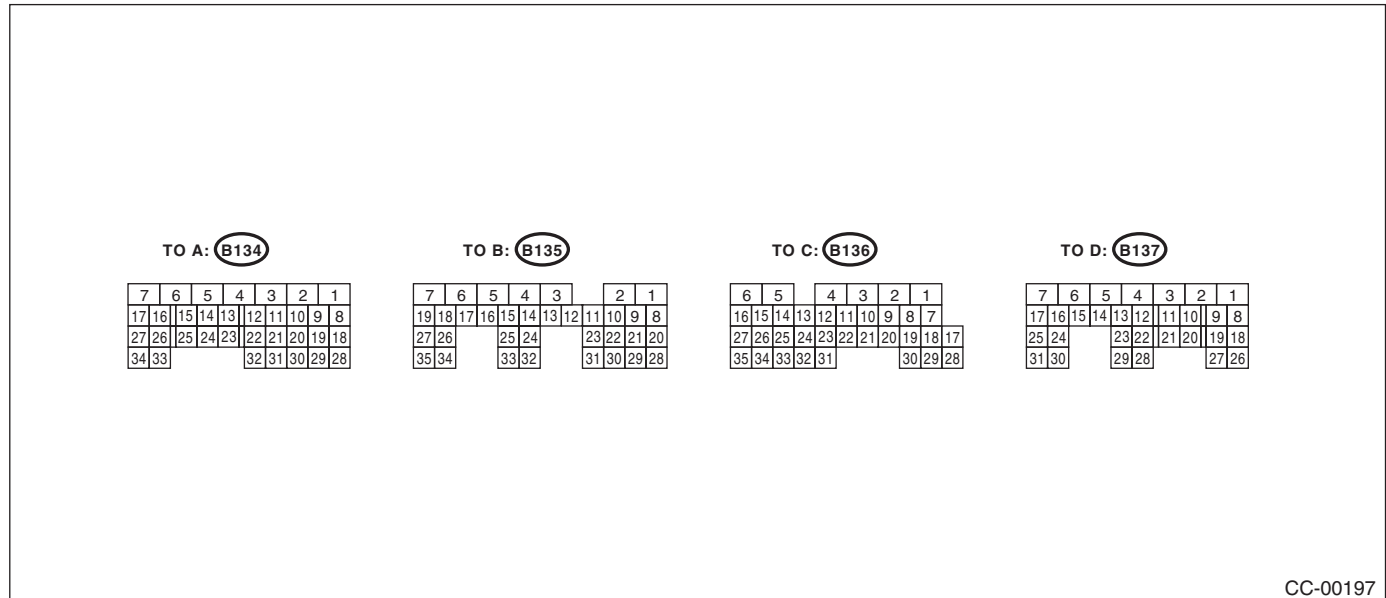

CC-00197

Contents		Terminal No.	Measurement condition and I/O signal (Idling with ignition ON: Except cruise set light)
Main power supply	VB (CONTROL 1) VB (CONTROL 2)	A7, B2	<ul style="list-style-type: none"> Battery voltage is detected when the main power is turned ON. "0 V" is detected when the main power is turned OFF.
Command switch		B24	<ul style="list-style-type: none"> "0 V" is detected when the command switch is in CANCEL position. "Approx. 1 V" is present when the command switch is in SET/COAST position. "Approx. 3 V" is detected when the command switch is in RESUME/ACCEL position. "Approx. 4 V" is detected when the command switch is released.
Brake switch 1 (Brake switch)		B20	<ul style="list-style-type: none"> Battery voltage is detected when the brake pedal is released. "0 V" is present when brake pedal is depressed.
Brake switch 2 (Stop light switch)		B28	<ul style="list-style-type: none"> Battery voltage is present when brake pedal is depressed. "0 V" is detected when the brake pedal is released.
Main switch		B12	<ul style="list-style-type: none"> "0 V" is present while the main switch is pressed or turned on. Approx. "5 V" is detected when the main switch is OFF.
Ground	GND (CONTROL 1) GND (CONTROL 2)	A5 C15	—
Ignition switch		B19	<ul style="list-style-type: none"> Battery voltage is detected when the ignition switch is turned ON. "0 V" is detected when the ignition switch is turned OFF.
Clutch switch		C25	<ul style="list-style-type: none"> "0 V" is present when clutch pedal is depressed. Battery voltage is detected when the clutch pedal is released.
Neutral position switch (MT model)		C31	<ul style="list-style-type: none"> Battery voltage is present when the shift lever is set in any position other than neutral. "Approx. 0 V" is detected when the shift lever is in neutral position.

B: WIRING DIAGRAM

<Ref. to WI-124, WIRING DIAGRAM, Cruise Control System.>

5. Subaru Select Monitor

A: OPERATION

1. GENERAL DESCRIPTION

The on-board diagnosis function of the cruise control system uses Subaru Select Monitor.

The on-board diagnosis function operates in two categories, which are used depending on the type of problems;

1) Cruise Control Cancel Conditions Diagnosis:

(1) This category of diagnosis requires actual vehicle driving in order to determine the cause, as when cruise speed is cancelled during driving although cruise cancel condition is not entered.

(2) The ECM cruise control memory stores the cancel condition (cancel code) which occurred during driving. When there are multiple cancel conditions (cancel code), they are shown on the Subaru Select Monitor.

CAUTION:

- The cruise control memory stores not only the cruise “cancel” which occurred (although “cancel” operation is not entered by the driver), but also the “cancel” condition input by the driver.
- The latest memory content (latest code) is cleared when ignition switch is turned to OFF. However, memory content from switch fault diagnosis relating to the system and cruise control is retained as a fault history (DTC) even after the ignition switch is turned OFF.

2) Real-time Diagnosis:

Real-time diagnosis function is used to determine whether or not the input signal system is in good order, according to signal emitted from switches, sensors, etc.

(1) Vehicle cannot be driven at cruise speed when the problem occurs in the cruise control system or relevant circuits.

(2) Monitor the signal conditions from switches and sensors.

2. CRUISE CONTROL CANCEL CONDITIONS DIAGNOSIS

- 1) Prepare the Subaru Select Monitor kit.
- 2) Connect the diagnosis cable to the Subaru Select Monitor.
- 3) Connect the Subaru Select Monitor to the data link connector.
 - (1) Data link connector is located in the lower portion of the instrument panel (on the driver's side).

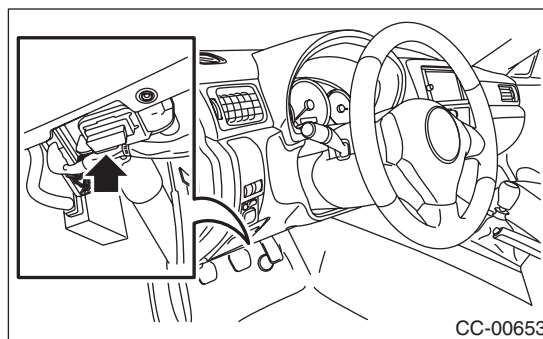

- (2) Connect the diagnosis cable to the data link connector.

- 4) Start the engine and turn the cruise control main switch to ON.
- 5) Run the Subaru Select Monitor.
- 6) On the «Main Menu» display screen, select {2. Each System Check}. On the system selection display screen, select the {Engine Control System} and the [OK]. Select the [OK] after the engine type information is displayed.
- 7) Drive vehicle at 40 km/h (25 MPH) or more and set the cruise control.

CAUTION:

- When performing diagnosis, observe the legal speed limit on the road.
- The cancel code will be also appear when cruise control is cancelled by the driver's operation. Do not confuse these.
- Be sure to get an assistant to support the diagnosis while driving, and have him/her operate the select monitor.

CRUISE CONTROL SYSTEM (DIAGNOSTICS)

8) When the set speed is canceled by itself (when cancelled without a cancel operation such as applying the brake) or if the cruise control could not be set by performing the setting operation, selecting the {Cancel Code(s) Display} on the engine malfunction diagnosis screen will display the cancel code on the select monitor display.

NOTE:

There are {Latest Diagnostic Code(s)} and {Memorized Diagnostic Code(s)} in DTC. The latest code recognized during current test drive is displayed in {Latest Diagnostic Code(s)}. DTCs by the diagnosis of faulty switches relating to the system and cruise control are displayed in {Memory Code}.

9) Perform Engine DTC Clear Memory operation.
<Ref. to EN(STI)(diag)-54, OPERATION, Clear Memory Mode.>

DTCs of switches relating to the system and cruise control are deleted by clearing memory on the engine side.

NOTE:

The latest code will be cleared by turning ignition switch to OFF.

3. REAL-TIME DIAGNOSIS

- 1) Connect the Subaru Select Monitor.
- 2) Turn the ignition switch and cruise control main switch to ON.
- 3) Run the Subaru Select Monitor.
- 4) On the «Main Menu» display screen, select {2. Each System Check}.
- 5) On the «System Selection» display screen, select the {Engine Control System}.
- 6) Select [OK] after engine type information is displayed.
- 7) Select {Current Data Display & Save} in «Cruise Control Diagnosis» display screen.
- 8) Make sure that normal display is shown when operated as follows:
 - Depress and release the brake pedal. (Stop light switch and brake switch are turned ON.)
 - Turn the main switch to ON.
 - Turn the “CANCEL” switch to ON.
 - Turn the “SET/COAST” switch to ON.
 - Turn the “RESUME/ACCEL” switch to ON.
 - Depress or release the clutch pedal.
 - Place the shift lever in any position other than neutral.

NOTE:

- For details concerning the operation procedures, refer to the “PC application help for Subaru Select Monitor”.
- Refer to “List of Diagnostic Trouble Code (DTC)” for DTC. <Ref. to CC(diag)-12, List of Diagnostic Trouble Code (DTC).>

6. Diagnostics with Phenomenon

A: DIAGNOSTIC PROCEDURE WITH PHENOMENON

Phenomenon		Check item	Reference
1	Cruise control main switch is not turned to ON. (Cruise indicator light does not illuminate.)	(1) Check the cruise indicator light.	<Ref. to CC(diag)-11, CHECK CRUISE INDICATOR LIGHT AND CRUISE SET INDICATOR LIGHT, Diagnostics with Phenomenon.>
		(2) Check the cruise control command switch.	<Ref. to CC(diag)-16, DTC 11, Diagnostic Procedure without Diagnostic Trouble Code (DTC).> <Ref. to CC(diag)-23, DTC 15, Diagnostic Procedure without Diagnostic Trouble Code (DTC).> <Ref. to CC(diag)-15, DTC 21, Diagnostic Procedure with Diagnostic Trouble Code (DTC).> <Ref. to CC(diag)-25, DTC 24, Diagnostic Procedure without Diagnostic Trouble Code (DTC).> <Ref. to CC(diag)-15, DTC 65, Diagnostic Procedure with Diagnostic Trouble Code (DTC).>
2	Cruise control cannot be set.	(1) Check the cruise control command switch.	<Ref. to CC(diag)-16, DTC 11, Diagnostic Procedure without Diagnostic Trouble Code (DTC).> <Ref. to CC(diag)-23, DTC 15, Diagnostic Procedure without Diagnostic Trouble Code (DTC).> <Ref. to CC(diag)-15, DTC 21, Diagnostic Procedure with Diagnostic Trouble Code (DTC).> <Ref. to CC(diag)-25, DTC 24, Diagnostic Procedure without Diagnostic Trouble Code (DTC).> <Ref. to CC(diag)-15, DTC 65, Diagnostic Procedure with Diagnostic Trouble Code (DTC).>
		(2) Check stop light switch and brake switch.	<Ref. to BR-34, Brake Pedal.> <Ref. to CC(diag)-18, DTC 12, Diagnostic Procedure without Diagnostic Trouble Code (DTC).> <Ref. to CC(diag)-25, DTC 25, Diagnostic Procedure without Diagnostic Trouble Code (DTC).> <Ref. to CC(diag)-15, DTC 61, Diagnostic Procedure with Diagnostic Trouble Code (DTC).>
		(3) Check clutch switch.	<Ref. to CL-23, Clutch Switch.> <Ref. to CC(diag)-20, DTC 13, Diagnostic Procedure without Diagnostic Trouble Code (DTC).>
		(4) Check the neutral position switch.	<Ref. to CC(diag)-22, DTC 14, Diagnostic Procedure without Diagnostic Trouble Code (DTC).> <Ref. to CC(diag)-26, DTC 62, Diagnostic Procedure without Diagnostic Trouble Code (DTC).>
		(5) Check vehicle speed sensor.	<Ref. to CC(diag)-25, DTC 22, Diagnostic Procedure without Diagnostic Trouble Code (DTC).> <Ref. to CC(diag)-25, DTC 32, Diagnostic Procedure without Diagnostic Trouble Code (DTC).> <Ref. to CC(diag)-26, DTC 63, Diagnostic Procedure without Diagnostic Trouble Code (DTC).>
3	Cruise set indicator light does not illuminate.	Check the cruise set indicator light.	<Ref. to CC(diag)-11, CHECK CRUISE INDICATOR LIGHT AND CRUISE SET INDICATOR LIGHT, Diagnostics with Phenomenon.>
4	Vehicle speed is not held within set speed ± 3 km/h (± 2 MPH).	Check the vehicle speed sensor.	<Ref. to CC(diag)-25, DTC 22, Diagnostic Procedure without Diagnostic Trouble Code (DTC).> <Ref. to CC(diag)-25, DTC 32, Diagnostic Procedure without Diagnostic Trouble Code (DTC).> <Ref. to CC(diag)-26, DTC 63, Diagnostic Procedure without Diagnostic Trouble Code (DTC).>

Diagnostics with Phenomenon

CRUISE CONTROL SYSTEM (DIAGNOSTICS)

Brought to you by Eris Studios
NOT FOR RESALE

Phenomenon		Check item	Reference
5	Vehicle speed does not increase or does not return to set speed after RESUME/ACCEL switch has been pressed.	Check the RESUME/ACCEL switch.	<Ref. to CC(diag)-16, DTC 11, Diagnostic Procedure without Diagnostic Trouble Code (DTC).> <Ref. to CC(diag)-23, DTC 15, Diagnostic Procedure without Diagnostic Trouble Code (DTC).> <Ref. to CC(diag)-15, DTC 21, Diagnostic Procedure with Diagnostic Trouble Code (DTC).> <Ref. to CC(diag)-25, DTC 24, Diagnostic Procedure without Diagnostic Trouble Code (DTC).> <Ref. to CC(diag)-15, DTC 65, Diagnostic Procedure with Diagnostic Trouble Code (DTC).>
6	Vehicle speed does not decrease after SET/COAST switch has been pressed.	Check the SET/COAST switch.	<Ref. to CC(diag)-16, DTC 11, Diagnostic Procedure without Diagnostic Trouble Code (DTC).> <Ref. to CC(diag)-23, DTC 15, Diagnostic Procedure without Diagnostic Trouble Code (DTC).> <Ref. to CC(diag)-15, DTC 21, Diagnostic Procedure with Diagnostic Trouble Code (DTC).> <Ref. to CC(diag)-25, DTC 24, Diagnostic Procedure without Diagnostic Trouble Code (DTC).> <Ref. to CC(diag)-15, DTC 65, Diagnostic Procedure with Diagnostic Trouble Code (DTC).>
7	Cruise control is not released after CANCEL switch has been pressed.	Check the CANCEL switch.	<Ref. to CC(diag)-16, DTC 11, Diagnostic Procedure without Diagnostic Trouble Code (DTC).> <Ref. to CC(diag)-23, DTC 15, Diagnostic Procedure without Diagnostic Trouble Code (DTC).> <Ref. to CC(diag)-15, DTC 21, Diagnostic Procedure with Diagnostic Trouble Code (DTC).> <Ref. to CC(diag)-25, DTC 24, Diagnostic Procedure without Diagnostic Trouble Code (DTC).> <Ref. to CC(diag)-15, DTC 65, Diagnostic Procedure with Diagnostic Trouble Code (DTC).>
8	Cruise control is not released after brake pedal has been depressed.	Check the stop light switch and brake switch.	<Ref. to CC(diag)-18, DTC 12, Diagnostic Procedure without Diagnostic Trouble Code (DTC).> <Ref. to CC(diag)-25, DTC 25, Diagnostic Procedure without Diagnostic Trouble Code (DTC).> <Ref. to CC(diag)-15, DTC 61, Diagnostic Procedure with Diagnostic Trouble Code (DTC).>
9	Cruise control is not released after shifting to the neutral position.	Check the neutral position switch.	<Ref. to CC(diag)-22, DTC 14, Diagnostic Procedure without Diagnostic Trouble Code (DTC).> <Ref. to CC(diag)-26, DTC 62, Diagnostic Procedure without Diagnostic Trouble Code (DTC).>
10	Cruise control is not released after clutch pedal has been depressed.	Check the clutch switch.	<Ref. to CC(diag)-20, DTC 13, Diagnostic Procedure without Diagnostic Trouble Code (DTC).>

Diagnostics with Phenomenon

CRUISE CONTROL SYSTEM (DIAGNOSTICS)

B: CHECK CRUISE INDICATOR LIGHT AND CRUISE SET INDICATOR LIGHT

TROUBLE SYMPTOM:

Cruise control can be set, but the cruise indicator light and cruise set indicator light do not illuminate.

Step	Check	Yes	No
1 CHECK CRUISE INDICATOR LIGHT AND CRUISE SET INDICATOR LIGHT. 1) Perform the self-diagnosis of combination meter. <Ref. to IDI-4, SELF-DIAGNOSIS, INSPECTION, Combination Meter System.> 2) Check the cruise indicator light and cruise set indicator light if they illuminate.	Do the cruise indicator light and cruise set indicator light illuminate?	Go to step 2.	Replace the meter case assembly. <Ref. to IDI-13, Combination Meter.>
2 CHECK DTC OF LAN COMMUNICATION CIRCUIT. 1) Complete self-diagnosis, and turn the ignition switch to ON again. 2) Read the DTC of body integrated unit using Subaru Select Monitor.	Is DTC of Low-speed CAN displayed?	Check the LAN communication circuit.	Replace the ECM. <Ref. to FU(STI)-49, Engine Control Module (ECM).>

List of Diagnostic Trouble Code (DTC)

CRUISE CONTROL SYSTEM (DIAGNOSTICS)

Brought to you by Eris Studios
NOT FOR RESALE

7. List of Diagnostic Trouble Code (DTC)

A: LIST

DTC	Item	Contents of diagnosis	Reference
21	Cruise control switch malfunction when ignition switch is turned to ON	When the ignition switch is turned to ON, each switch of cruise control command switch is already turned to ON.	This DTC is displayed when the ignition switch is turned to ON without operating the cruise control command switch. <Ref. to CC(diag)-15, DTC 21, Diagnostic Procedure with Diagnostic Trouble Code (DTC).>
61	Brake switch abnormal	Malfunction in the stop light & brake switch is detected.	<Ref. to CC(diag)-15, DTC 61, Diagnostic Procedure with Diagnostic Trouble Code (DTC).>
65	Cruise control related switch malfunction 1	Cruise control command switch malfunction is detected. (While the switch is pressed ON for a long time (approximately two minutes), stuck ON condition is detected.)	<Ref. to CC(diag)-15, DTC 65, Diagnostic Procedure with Diagnostic Trouble Code (DTC).>

List of Cancel Code

CRUISE CONTROL SYSTEM (DIAGNOSTICS)

Brought to you by Eris Studios
NOT FOR SALE

8. List of Cancel Code

A: LIST

NOTE:

- Cancel codes are cleared if the ignition switch is turned to OFF.
- If an additional cancel code is input after a code has input, it is overwritten.
- To display a cancel code, use the Subaru Select Monitor to read the code after the cruise control is deactivated during a driving test.

Cancel code	Item	Contents of diagnosis	Reference
11	Main switch	Main switch of cruise control command switch is turned to OFF, and then the cruise control is released.	This DTC is displayed without operating the main switch. <Ref. to CC(diag)-16, DTC 11, Diagnostic Procedure without Diagnostic Trouble Code (DTC).>
12	Stop & Brake switch	Stop light switch or brake switch is turned to ON, and then the cruise control is released.	This DTC is displayed without depressing the brake pedal. <Ref. to CC(diag)-18, DTC 12, Diagnostic Procedure without Diagnostic Trouble Code (DTC).>
13	Clutch switch	Clutch switch is turned to ON, and then the cruise control is released.	This DTC is displayed without depressing the clutch pedal. <Ref. to CC(diag)-20, DTC 13, Diagnostic Procedure without Diagnostic Trouble Code (DTC).>
14	Neutral switch	Neutral position switch is turned to ON, and then the cruise control is released.	This DTC is displayed without shifting to neutral position. <Ref. to CC(diag)-22, DTC 14, Diagnostic Procedure without Diagnostic Trouble Code (DTC).>
15	Cancel switch	Cancel switch is turned to ON, and then the cruise control is released.	This DTC is displayed without operating the cancel switch. <Ref. to CC(diag)-23, DTC 15, Diagnostic Procedure without Diagnostic Trouble Code (DTC).>
16	Ignition switch	Ignition switch is turned to OFF, and then the cruise control is released.	This DTC is displayed without operating the ignition switch. <Ref. to CC(diag)-24, DTC 16, Diagnostic Procedure without Diagnostic Trouble Code (DTC).>
22	Abnormality of change in vehicle speed	Malfunction of vehicle speed signal variation is detected.	<Ref. to CC(diag)-25, DTC 22, Diagnostic Procedure without Diagnostic Trouble Code (DTC).>
24	Abnormality of switches related to cruise control	Open circuit of cruise control switch is detected during cruise driving. (The system is judged as model without cruise control.)	This DTC is displayed with normal operation. <Ref. to CC(diag)-25, DTC 24, Diagnostic Procedure without Diagnostic Trouble Code (DTC).>
25	Brake Switch Input Circuit Malfunction	Malfunction of brake switch input circuit in ECM is detected.	<Ref. to CC(diag)-25, DTC 25, Diagnostic Procedure without Diagnostic Trouble Code (DTC).>
31	Engine speed signal	<ul style="list-style-type: none"> • Abnormal increase of engine speed is detected. • Gear is placed in Neutral, 1st or Reverse position. 	Cruise in 2nd shift position or more. <Ref. to CC(diag)-25, DTC 31, Diagnostic Procedure without Diagnostic Trouble Code (DTC).>

List of Cancel Code

CRUISE CONTROL SYSTEM (DIAGNOSTICS)

Brought to you by Eris Studios
NOT FOR RESALE

Cancel code	Item	Contents of diagnosis	Reference
32	Cruise control out of Range	<ul style="list-style-type: none"> • Controlled vehicle speed decreased under the limit during cruising. • Set operation was performed at vehicle speed unavailable for setting. • RESUME operation was performed without memorized vehicle speed. 	<p>This DTC is displayed, though the vehicle speed is increased to the speed available for cruise set and set operation was performed again.</p> <p><Ref. to CC(diag)-25, DTC 32, Diagnostic Procedure without Diagnostic Trouble Code (DTC).></p>
34	Prohibition of cruise control at continuing big Accel. angle	The vehicle has been driven at higher speed than set vehicle speed for an abnormally long time (approximately 10 minutes) during cruise driving.	<p>This DTC is displayed when driving for a long period of time at higher speed than appropriate cruise set vehicle speed by operating accelerator pedal. In this case, the cruise setting is deactivated.</p> <p><Ref. to CC(diag)-25, DTC 34, Diagnostic Procedure without Diagnostic Trouble Code (DTC).></p>
35	Prohibition of cruise control at vehicle speed feedback malfunction	Set vehicle speed cannot be kept because of some reasons (steep uphill, parking brake, abnormal decrease of engine output, etc.) during cruise driving.	<p>This DTC is displayed when driving condition is not suitable for cruise control. Perform cruise set operation again after clearing the possible cause.</p> <p><Ref. to CC(diag)-26, DTC 35, Diagnostic Procedure without Diagnostic Trouble Code (DTC).></p>
41	VDC/TCS Operating	Vehicle dynamics control (VDC) or TCS was operated during cruise driving or while setting cruise control.	<p>This DTC is displayed when driving condition is not suitable for cruise control. Perform cruise set operation again after clearing the possible cause.</p> <p><Ref. to CC(diag)-26, DTC 41, Diagnostic Procedure without Diagnostic Trouble Code (DTC).></p>
43	ABS/VDC Failure	ABS or Vehicle dynamics control (VDC) system malfunction is detected during cruise driving or cruise setting.	<Ref. to CC(diag)-26, DTC 43, Diagnostic Procedure without Diagnostic Trouble Code (DTC).>
44	Body Integrated unit Failure	Body integrated unit system malfunction is detected during cruise driving or cruise setting.	<Ref. to CC(diag)-26, DTC 44, Diagnostic Procedure without Diagnostic Trouble Code (DTC).>
45	Meter Failure	Combination meter malfunction is detected during cruise driving or cruise setting.	<Ref. to CC(diag)-26, DTC 45, Diagnostic Procedure without Diagnostic Trouble Code (DTC).>
62	Neutral Switch Failure	Neutral position switch malfunction is detected.	<Ref. to CC(diag)-26, DTC 62, Diagnostic Procedure without Diagnostic Trouble Code (DTC).>
63	Abnormality 1 of change in vehicle speed	Malfunction of vehicle speed signal variation is detected.	<Ref. to CC(diag)-26, DTC 63, Diagnostic Procedure without Diagnostic Trouble Code (DTC).>
64	Engine sensor related sensor malfunction 1	Malfunction related to engine is detected.	<Ref. to CC(diag)-26, DTC 64, Diagnostic Procedure without Diagnostic Trouble Code (DTC).>
66	Cruise Control Calculation Error	Cruise control calculation (microcomputer) malfunction is detected.	<Ref. to CC(diag)-26, DTC 66, Diagnostic Procedure without Diagnostic Trouble Code (DTC).>

Brought to you by Eris Studios
NOT FOR SALE

9. Diagnostic Procedure with Diagnostic Trouble Code (DTC)

A: DTC 21

Cruise control command switch malfunction is detected.

TROUBLE SYMPTOM:

- Cruise control cannot be set. (Cancelled immediately.)
- Cruise control cannot be released.

Refer to DTC 11 for diagnostic procedure.

<Ref. to CC(diag)-16, DTC 11, Diagnostic Procedure without Diagnostic Trouble Code (DTC).>

B: DTC 61

Malfunction in the stop light & brake switch is detected.

TROUBLE SYMPTOM:

- Cruise control cannot be set.
- Cruise control cannot be released.

Refer to DTC 12 for diagnostic procedure.

<Ref. to CC(diag)-18, DTC 12, Diagnostic Procedure without Diagnostic Trouble Code (DTC).>

C: DTC 65

Cruise control command switch malfunction is detected.

While the command switch is pressed ON for a long time (approximately two minutes), stuck ON condition is detected.

TROUBLE SYMPTOM:

- Cruise control cannot be set. (Cancelled immediately.)
- Cruise control cannot be released.

Refer to DTC 11 for diagnostic procedure.

<Ref. to CC(diag)-16, DTC 11, Diagnostic Procedure without Diagnostic Trouble Code (DTC).>

Diagnostic Procedure without Diagnostic Trouble Code (DTC)

CRUISE CONTROL SYSTEM (DIAGNOSTICS)

Brought to you by Eris Studios
NOT FOR RESALE

10. Diagnostic Procedure without Diagnostic Trouble Code (DTC)

A: DTC 11

The malfunction is detected when the main switch is pressed or problem relating to the main switch occurs.

TROUBLE SYMPTOM:

- Cruise control cannot be set. (Cancelled immediately.)
- Cruise control cannot be released.

WIRING DIAGRAM:

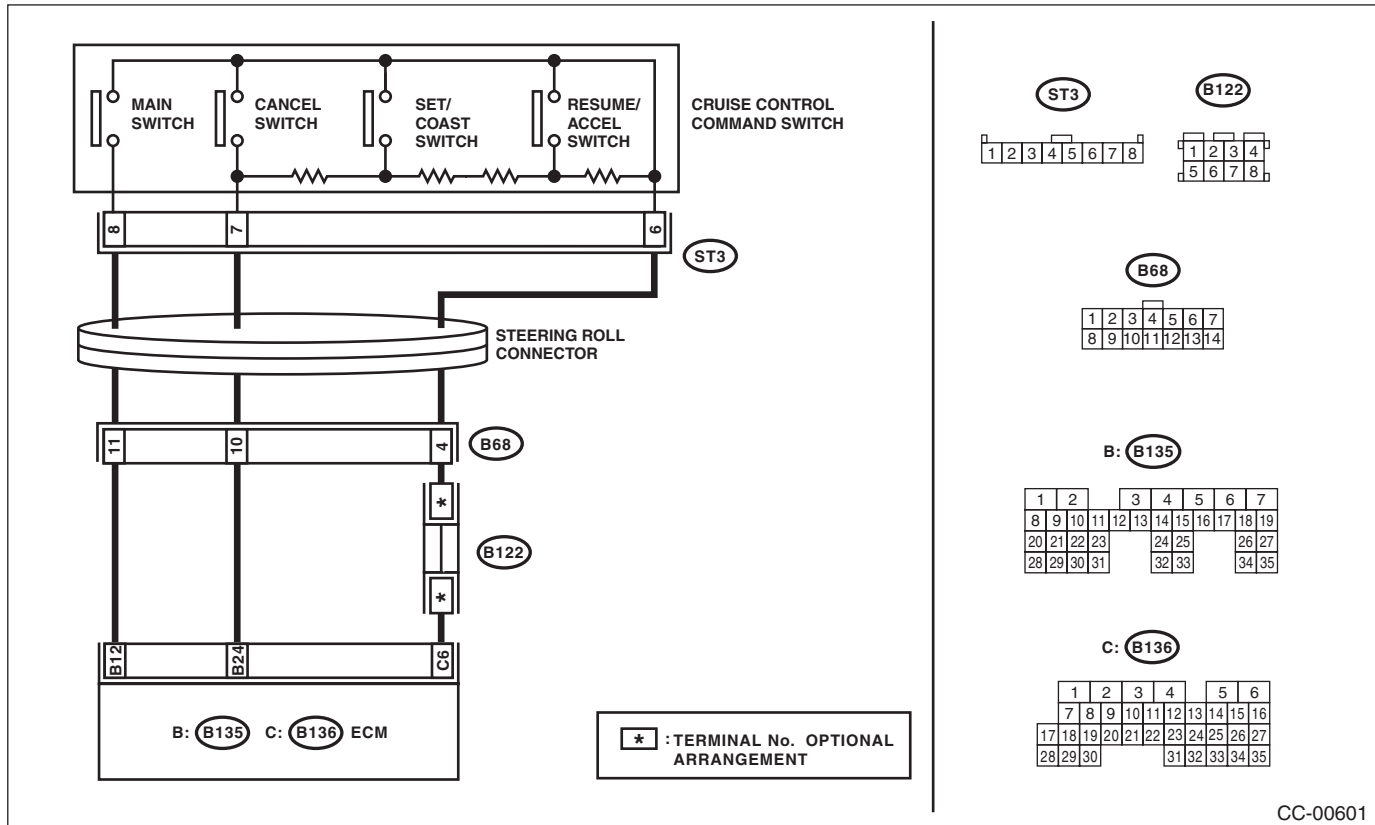

CC-00601

Diagnostic Procedure without Diagnostic Trouble Code (DTC)

CRUISE CONTROL SYSTEM (DIAGNOSTICS)

Step	Check	Yes	No
1 CHECK CRUISE CONTROL COMMAND SWITCH CIRCUIT. 1) Remove the driver's airbag module. <Ref. to AB-16, REMOVAL, Driver's Airbag Module.> 2) Disconnect the harness connector of cruise control command switch. 3) Turn the ignition switch to ON. 4) Measure the voltage between harness connector terminal and chassis ground. Connector & terminal (ST3) No. 8 (+) — Chassis ground (-): (ST3) No. 7 (+) — Chassis ground (-):	Is the voltage 5 V or more?	Go to step 2.	Check the harness between cruise control command switch and ECM, and the steering roll connector for open or short circuit, or for poor contact.
2 CHECK CRUISE CONTROL COMMAND SWITCH CIRCUIT. 1) Turn the ignition switch to OFF. 2) Remove the cruise control command switch. <Ref. to CC-5, REMOVAL, Cruise Control Command Switch.> 3) Measure the resistance between harness connector terminal and chassis ground. Connector terminal (ST3) No. 6 — Chassis ground:	Is the resistance less than 10 Ω?	Go to step 3.	Check for open between cruise control command switch and ECM and chassis ground, and check the ECM.
3 CHECK CRUISE CONTROL COMMAND SWITCH. Measure the resistance between switch terminals when the cruise control command switch is not being pressed. Terminal No. 6 — No. 7:	Is the resistance approx. 4 kΩ?	Go to step 4.	Replace the cruise control command switch. <Ref. to CC-5, Cruise Control Command Switch.>
4 CHECK CANCEL SWITCH. 1) Turn the ignition switch to OFF. 2) Remove the cruise control command switch. <Ref. to CC-5, REMOVAL, Cruise Control Command Switch.> 3) Measure the resistance between switch terminals when the CANCEL switch is pressed. Terminal No. 6 — No. 7:	Is the resistance approx. less than 1 Ω when the CANCEL switch is pressed?	Go to step 5.	Replace the cruise control command switch. <Ref. to CC-5, Cruise Control Command Switch.>
5 CHECK SET/COAST SWITCH. Measure the resistance between switch terminals when the SET/COAST switch is pressed. Terminal No. 6 — No. 7:	Is the resistance approx. 250 Ω when SET/COAST switch is pressed?	Go to step 6.	Replace the cruise control command switch. <Ref. to CC-5, Cruise Control Command Switch.>
6 CHECK RESUME/ACCEL SWITCH CIRCUIT. Measure the resistance between switch terminals when the RESUME/ACCEL switch is pressed. Terminal No. 6 — No. 7:	Is the resistance approx. 1,500 Ω when RESUME/ACCEL switch is pressed?	Replace the ECM. <Ref. to FU(STI)-49, Engine Control Module (ECM).>	Replace the cruise control command switch. <Ref. to CC-5, Cruise Control Command Switch.>

Diagnostic Procedure without Diagnostic Trouble Code (DTC)

CRUISE CONTROL SYSTEM (DIAGNOSTICS)

Brought to you by Eris Studios
NOT FOR RESALE

B: DTC 12

The DTC is detected when the brake pedal is pressed or problem relating to stop light & brake switch occurs.

TROUBLE SYMPTOM:

- Cruise control cannot be set.
- Cruise control cannot be released.

WIRING DIAGRAM:

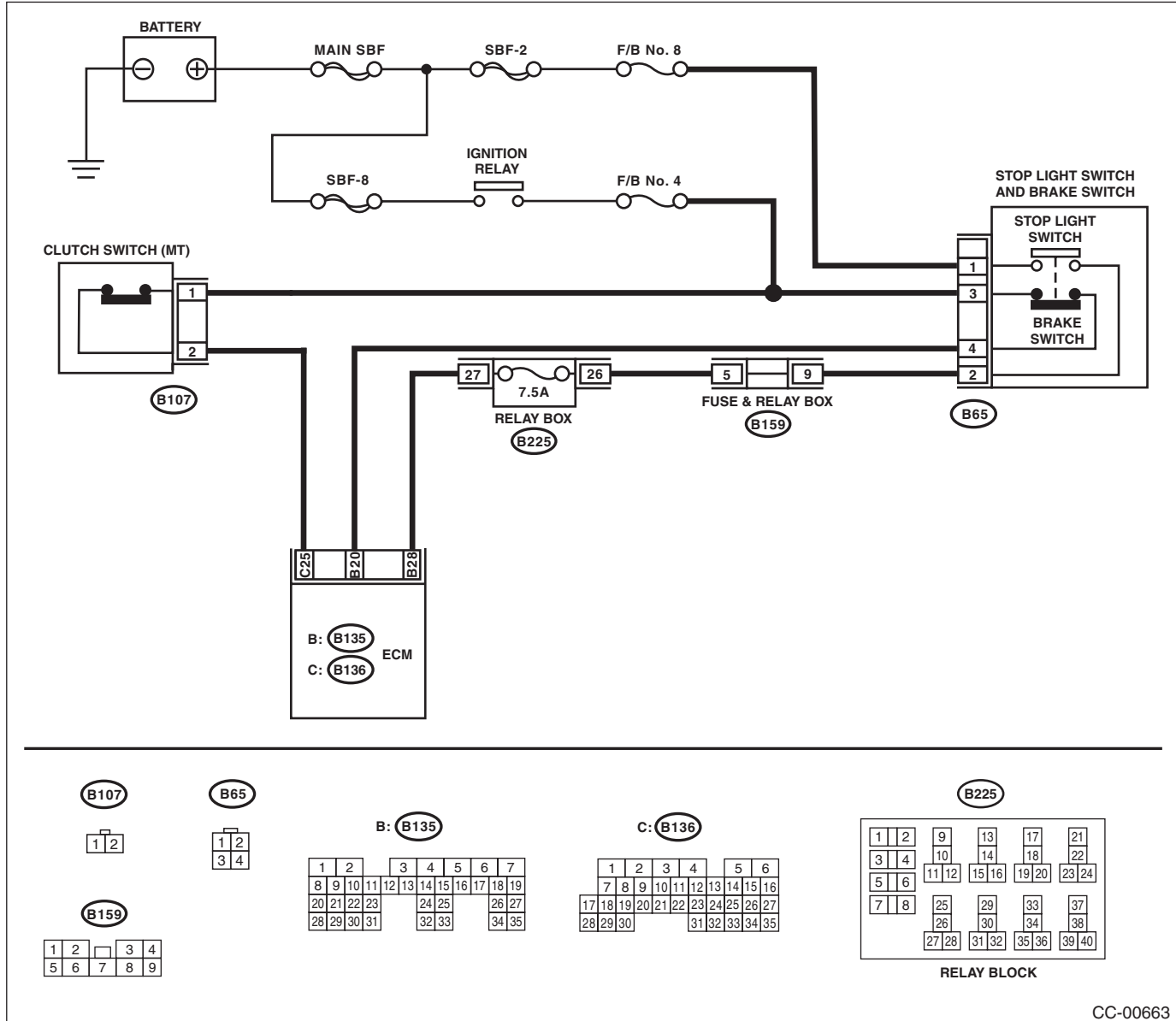

CC-00663

Diagnostic Procedure without Diagnostic Trouble Code (DTC)

CRUISE CONTROL SYSTEM (DIAGNOSTICS)

Brought to you by Eris Studios
 NOT FOR SALE

Step	Check	Yes	No
1 CHECK STOP LIGHT & BRAKE SWITCH CIRCUIT. 1) Turn the ignition switch to OFF. 2) Disconnect the stop light & brake switch harness connector. 3) Turn the ignition switch to ON. 4) Measure the voltage between harness connector terminal and chassis ground. Connector & terminal (B65) No. 1 (+) — Chassis ground (-):	Is the voltage 10 V or more?	Go to step 2.	<ul style="list-style-type: none"> • Check fuse No. 8 (in fuse & relay box). • Check for open or short in the harness between stop light & brake switch and fuse & relay box.
2 CHECK STOP LIGHT & BRAKE SWITCH CIRCUIT. Measure the voltage between harness connector terminal and chassis ground. Connector & terminal (B65) No. 3 (+) — Chassis ground (-):	Is the voltage 10 V or more?	Go to step 3.	<ul style="list-style-type: none"> • Check fuse No. 4 (in fuse & relay box). • Check for open or short in the harness between stop light & brake switch and fuse & relay box.
3 CHECK STOP LIGHT & BRAKE SWITCH CIRCUIT. 1) Turn the ignition switch to OFF. 2) Disconnect the harness connector of ECM. 3) Measure the resistance between ECM harness connector terminal and stop light & brake switch harness connector terminal. Connector & terminal (B135) No. 20 — (B65) No. 4: (B135) No. 28 — (B65) No. 2:	Is the resistance less than 10 Ω?	Go to step 4.	Repair the harness.
4 CHECK STOP LIGHT & BRAKE SWITCH CIRCUIT. Remove and check the stop light & brake switch. <Ref. to CC-7, Stop Light & Brake Switch.>	Is the stop light & brake switch OK?	Replace the ECM. <Ref. to FU(STI)-49, Engine Control Module (ECM).>	Replace the stop light & brake switch.

Diagnostic Procedure without Diagnostic Trouble Code (DTC)

CRUISE CONTROL SYSTEM (DIAGNOSTICS)

Brought to you by Eris Studios
NOT FOR RESALE

C: DTC 13

The DTC is detected when the clutch pedal is depressed or problem relating to the clutch switch occurs.

TROUBLE SYMPTOM:

- Cruise control cannot be set.
- Cruise control cannot be released.

WIRING DIAGRAM:

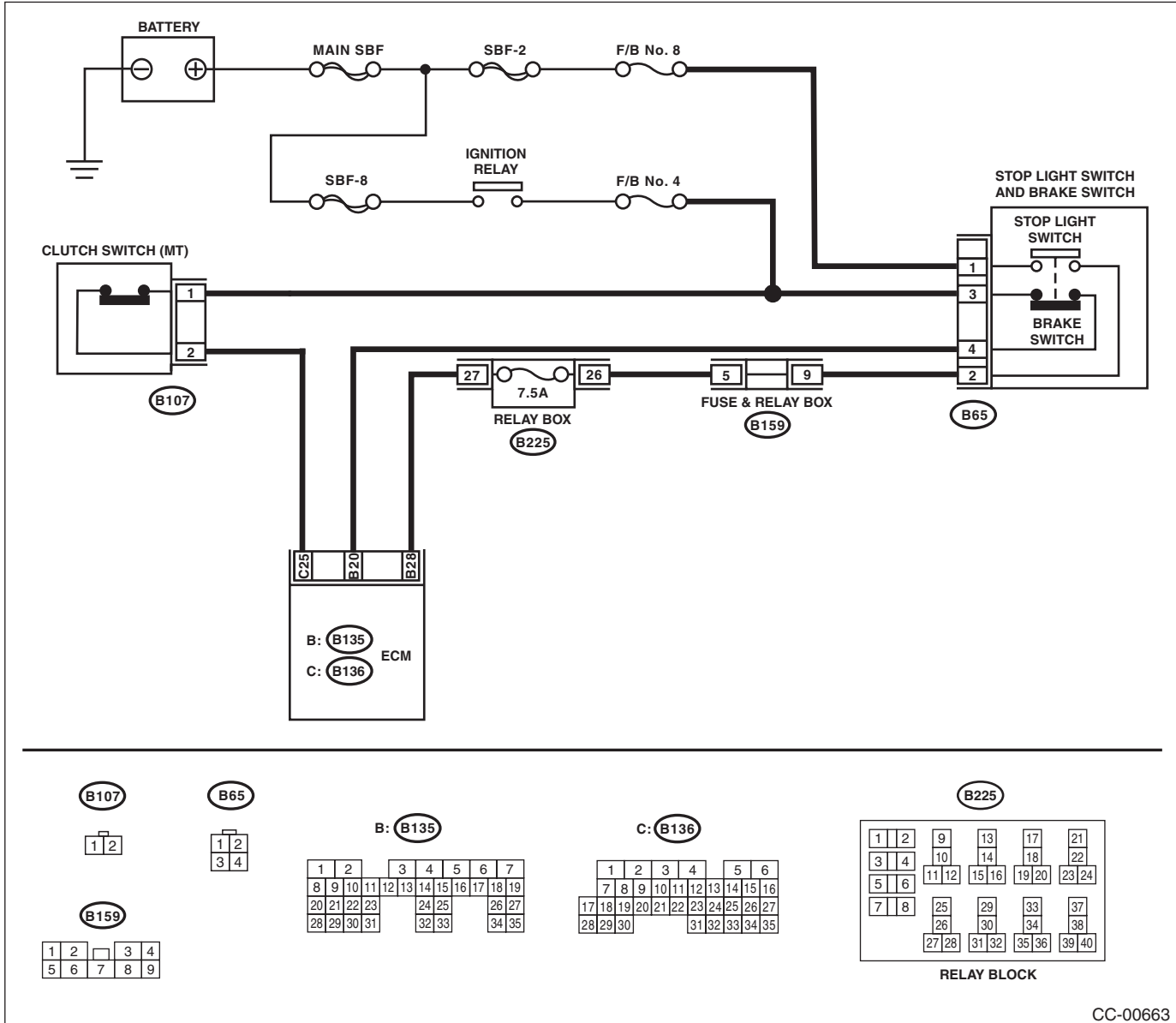

CC-00663

Diagnostic Procedure without Diagnostic Trouble Code (DTC)

CRUISE CONTROL SYSTEM (DIAGNOSTICS)

Brought to you by Eris Studios
 NOT FOR SALE

Step	Check	Yes	No
1 CHECK CLUTCH SWITCH CIRCUIT. 1) Turn the ignition switch to OFF. 2) Disconnect the clutch switch harness connector. 3) Turn the ignition switch to ON. 4) Measure the voltage between harness connector terminal and chassis ground. Connector & terminal (B107) No. 1 (+) — Chassis ground (-):	Is the voltage 10 V or more?	Go to step 2.	<ul style="list-style-type: none"> • Check fuse No. 4 (in fuse & relay box). • Check open or shorted circuit of harness between clutch switch and fuse & relay box.
2 CHECK CLUTCH SWITCH CIRCUIT. 1) Turn the ignition switch to OFF. 2) Disconnect the harness connector of ECM. 3) Measure the resistance between clutch switch harness connector terminal and ECM harness connector terminal. Connector & terminal (B107) No. 2 — (B136) No. 25:	Is the resistance less than 10 Ω?	Go to step 3.	Repair the harness.
3 CHECK CLUTCH SWITCH. Remove and check the clutch switch. <Ref. to CL-23, INSPECTION, Clutch Switch.>	Is clutch switch OK?	Replace the ECM. <Ref. to FU(STI)-49, Engine Control Module (ECM).>	Replace the clutch switch.

Diagnostic Procedure without Diagnostic Trouble Code (DTC)

CRUISE CONTROL SYSTEM (DIAGNOSTICS)

Brought to you by Eris Studios
NOT FOR SALE

D: DTC 14

The DTC is detected when the select lever is placed in neutral position or problem relating to the neutral position switch occurs.

TROUBLE SYMPTOM:

Cruise control cannot be set.

WIRING DIAGRAM:

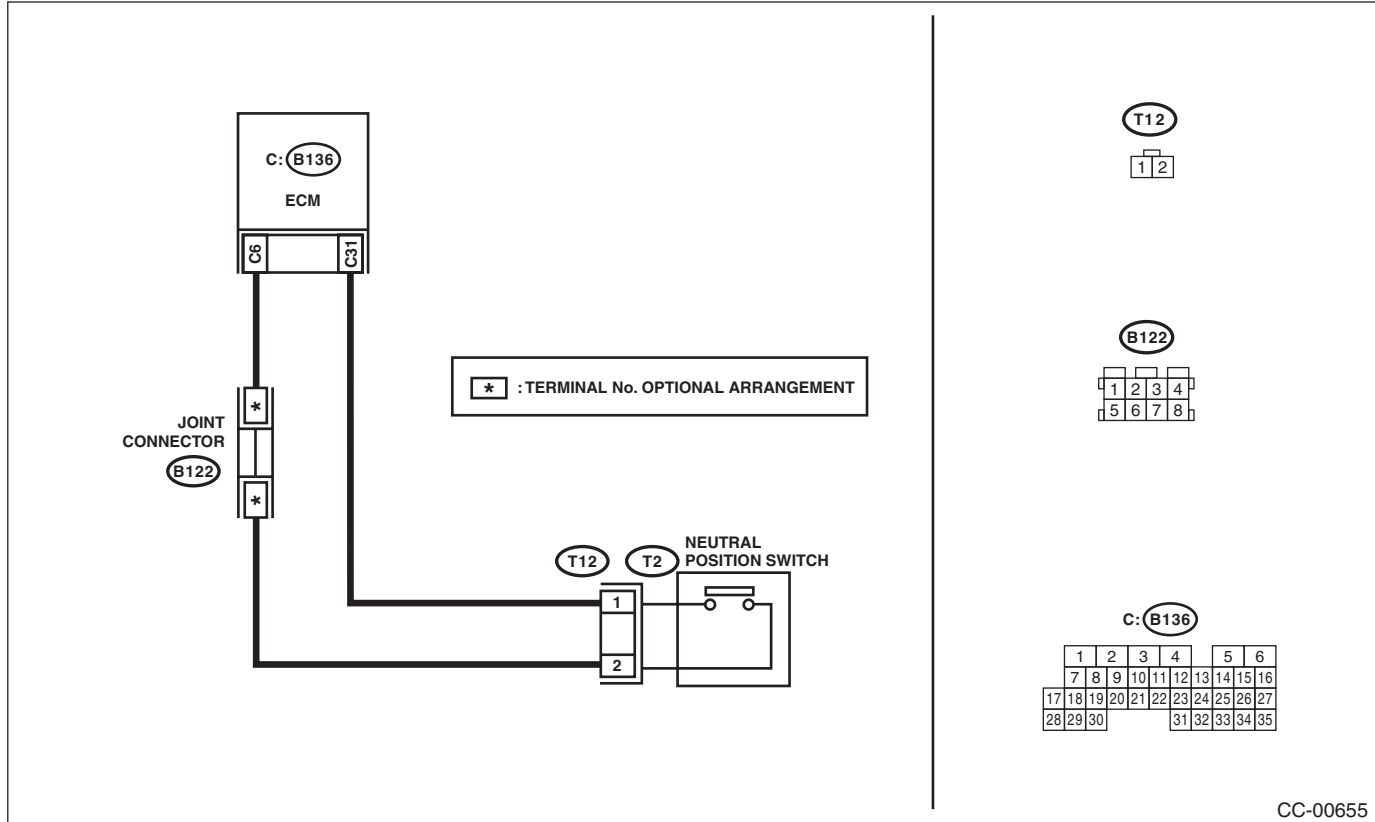

Step	Check	Yes	No
1 CHECK NEUTRAL POSITION SWITCH CIRCUIT. 1) Turn the ignition switch to OFF. 2) Disconnect the neutral position switch harness connector. 3) Turn the ignition switch to ON. 4) Measure the voltage between harness connector terminal and chassis ground. Connector & terminal (T12) No. 2 (+) — Chassis ground (-):	Is the voltage approx. 5 V?	Go to step 2.	Check for open or short in the harness between neutral position switch and ECM.
2 CHECK NEUTRAL POSITION SWITCH CIRCUIT. 1) Turn the ignition switch to OFF. 2) Measure resistance between harness connector terminal of neutral position switch and chassis ground. Connector & terminal (T12) No. 1 — Chassis ground:	Is the resistance less than 10 Ω?	Go to step 3.	Repair the harness.
3 CHECK NEUTRAL POSITION SWITCH. Remove and check the neutral position switch.	Is the neutral position switch OK?	Replace the ECM. <Ref. to FU(STI)-49, Engine Control Module (ECM).>	Replace the neutral position switch.

Diagnostic Procedure without Diagnostic Trouble Code (DTC)

CRUISE CONTROL SYSTEM (DIAGNOSTICS)

E: DTC 15

This DTC is detected when the cancel switch is pressed or problem relating to the main switch occurs.

TROUBLE SYMPTOM:

- Cruise control cannot be set. (Cancelled immediately.)
- Cruise control cannot be released.

Refer to DTC 11 for diagnostic procedure.

<Ref. to CC(diag)-16, DTC 11, Diagnostic Procedure without Diagnostic Trouble Code (DTC).>

Brought to you by Eris Studios
NOT FOR SALE

Diagnostic Procedure without Diagnostic Trouble Code (DTC)

CRUISE CONTROL SYSTEM (DIAGNOSTICS)

Brought to you by Eris Studios
NOT FOR RESALE

F: DTC 16

This DTC is detected when the ignition switch is turned OFF or problem relating to the ignition switch occurs.

TROUBLE SYMPTOM:

Cruise control cannot be set.

WIRING DIAGRAM:

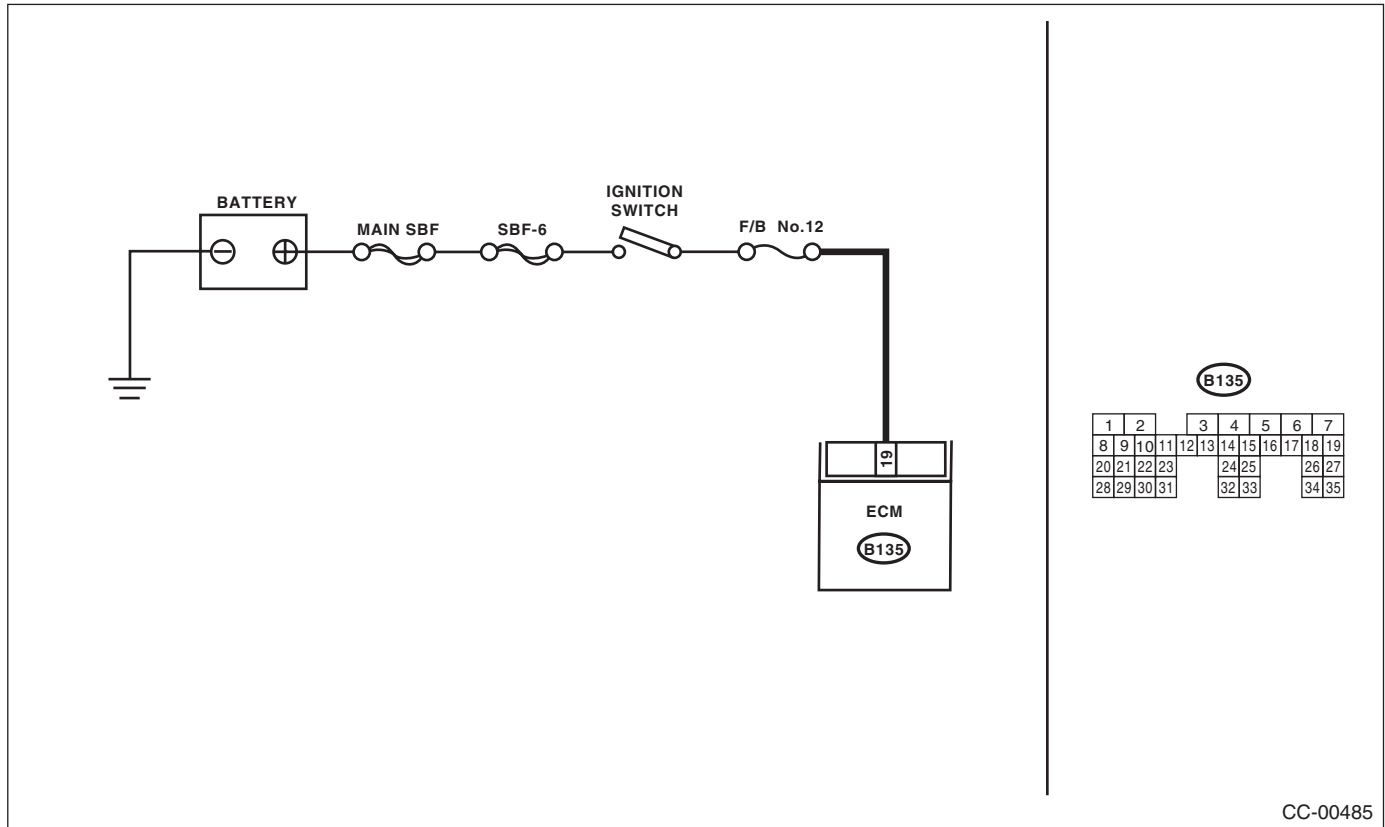

CC-00485

Step	Check	Yes	No
1 CHECK IGNITION SWITCH CIRCUIT. 1) Turn the ignition switch to OFF. 2) Disconnect the ECM harness connector. 3) Turn the ignition switch to ON. 4) Measure the voltage between harness connector terminal and chassis ground. Connector & terminal (B135) No. 19 (+) — Chassis ground (-):	Is the voltage 10 V or more?	Check for poor contact of the ECM connector.	<ul style="list-style-type: none"> Check fuse No. 12 (in fuse & relay box). Check the harness for open or short circuit between ignition switch and ECM.

Diagnostic Procedure without Diagnostic Trouble Code (DTC)

CRUISE CONTROL SYSTEM (DIAGNOSTICS)

G: DTC 22

Malfunction related to vehicle speed sensor is detected.

DIAGNOSIS:

Open or shorted circuit in vehicle speed sensor system.

TROUBLE SYMPTOM:

Cruise control cannot be set. (Cancelled immediately.)

	Step	Check	Yes	No
1	CHECK ABS OR VDC WARNING LIGHT. 1) Turn the ignition switch to ON. 2) After the initial operation of the combination meter is completed, check whether the VDC warning light continues to illuminate.	Does the warning light continue to illuminate?	Check the VDCCM. <Ref. to VDC(diag)-2, Basic Diagnostic Procedure.>	Go to step 2.
2	CHECK DTC OF LAN COMMUNICATION CIRCUIT. Read the DTC of body integrated unit using Subaru Select Monitor.	Is DTC of Low-speed CAN displayed?	Check the LAN communication circuit.	Replace the ECM. <Ref. to FU(STI)-49, Engine Control Module (ECM).>

H: DTC 24

Malfunction in cruise control-related switch is detected.

TROUBLE SYMPTOM:

- Cruise control cannot be set. (Cancelled immediately.)
- Cruise control cannot be released.

Refer to DTC 11 for diagnostic procedure.

<Ref. to CC(diag)-16, DTC 11, Diagnostic Procedure without Diagnostic Trouble Code (DTC).>

I: DTC 25

Malfunction of brake input circuit in ECM is detected.

Refer to the Engine Diagnostic Procedure for diagnostic procedure.

J: DTC 31

Malfunction of the engine speed signal is detected.

Abnormal increase of engine speed is detected.

Gear is set to 1st or Reverse position.

After driving at the 2nd gear position or more, perform the cruise setting again. If the DTC is not detected, it is normal.

K: DTC 32

This DTC is detected out of vehicle speed range.

Increase vehicle speed high enough to allow the cruise control to function, and then perform setting operation again.

If the DTC is detected after performing the setting operation, perform DTC 22 diagnosis.

Refer to DTC 22 for diagnostic procedure.

<Ref. to CC(diag)-25, DTC 22, Diagnostic Procedure without Diagnostic Trouble Code (DTC).>

L: DTC 34

The vehicle has been driven at a speed higher than set speed for a long time (approximately 10 minutes) during cruise driving.

DTC is detected when driving for a long period of time at higher speed than appropriate cruise speed by operating accelerator pedal.

Perform the cruise control setting operation again. If the DTC is not detected, it is normal.

Diagnostic Procedure without Diagnostic Trouble Code (DTC)

CRUISE CONTROL SYSTEM (DIAGNOSTICS)

Brought to you by Eris Studios
NOT FOR RESALE

M: DTC 35

Detected when it is impossible to perform the vehicle speed feedback.

Set vehicle speed cannot be kept for some reasons (steep uphill, unreleased parking brake, etc.) during cruise driving.

DTC is detected when driving condition is not suitable for cruise control.

Perform cruise set operation again after clearing the possible cause.

N: DTC 41

VDC/TCS has operated.

Vehicle dynamics control (VDC) or TCS is operated during cruise driving or cruise setting.

<Ref. to VDC(diag)-2, PROCEDURE, Basic Diagnostic Procedure.>

O: DTC 43

ABS/VDC malfunction is detected.

VDC malfunction is detected during cruise driving or cruise setting.

<Ref. to VDC(diag)-2, PROCEDURE, Basic Diagnostic Procedure.>

P: DTC 44

Body integrated unit malfunction is detected.

Body integrated unit system malfunction is detected during cruise driving or cruise setting.

Q: DTC 45

Malfunction of the combination meter is detected.

Combination meter malfunction is detected during cruise driving or cruise setting.

R: DTC 62

Neutral position switch malfunction is detected.

TROUBLE SYMPTOM:

Cruise control cannot be set.

Refer to DTC 14 for diagnostic procedure.

<Ref. to CC(diag)-22, DTC 14, Diagnostic Procedure without Diagnostic Trouble Code (DTC).>

S: DTC 63

Malfunction of vehicle speed signal variation is detected.

TROUBLE SYMPTOM:

Cruise control cannot be set. (Cancelled immediately.)

Refer to DTC 22 for diagnostic procedure.

<Ref. to CC(diag)-25, DTC 22, Diagnostic Procedure without Diagnostic Trouble Code (DTC).>

T: DTC 64

Malfunction related to engine is detected.

Refer to the Engine Diagnostic Procedure for diagnostic procedure.

<Ref. to EN(STI)(diag)-2, PROCEDURE, Basic Diagnostic Procedure.>

U: DTC 66

Cruise control calculation malfunction is detected.

Refer to the Engine Diagnostic Procedure for diagnostic procedure.

<Ref. to EN(STI)(diag)-2, PROCEDURE, Basic Diagnostic Procedure.>