

Brought to you by Eris Studios  
NOT FOR RESALE

# DRIVE SHAFT SYSTEM

# General Description

## DRIVE SHAFT SYSTEM

Brought to you by Eris Studios  
NOT FOR SALE

### 1. General Description

#### A: SPECIFICATION

##### 1. PROPELLER SHAFT

Propeller shaft type		3UJ
Front propeller shaft Joint-to-joint length: $L_1$	mm (in)	633 (24.92)
Rear propeller shaft Joint-to-Joint length: $L_2$	mm (in)	728.5 (28.68)
Outer diameter of tube:	$D_1$	70.0 (2.756)
	$D_2$	57.0 (2.244)

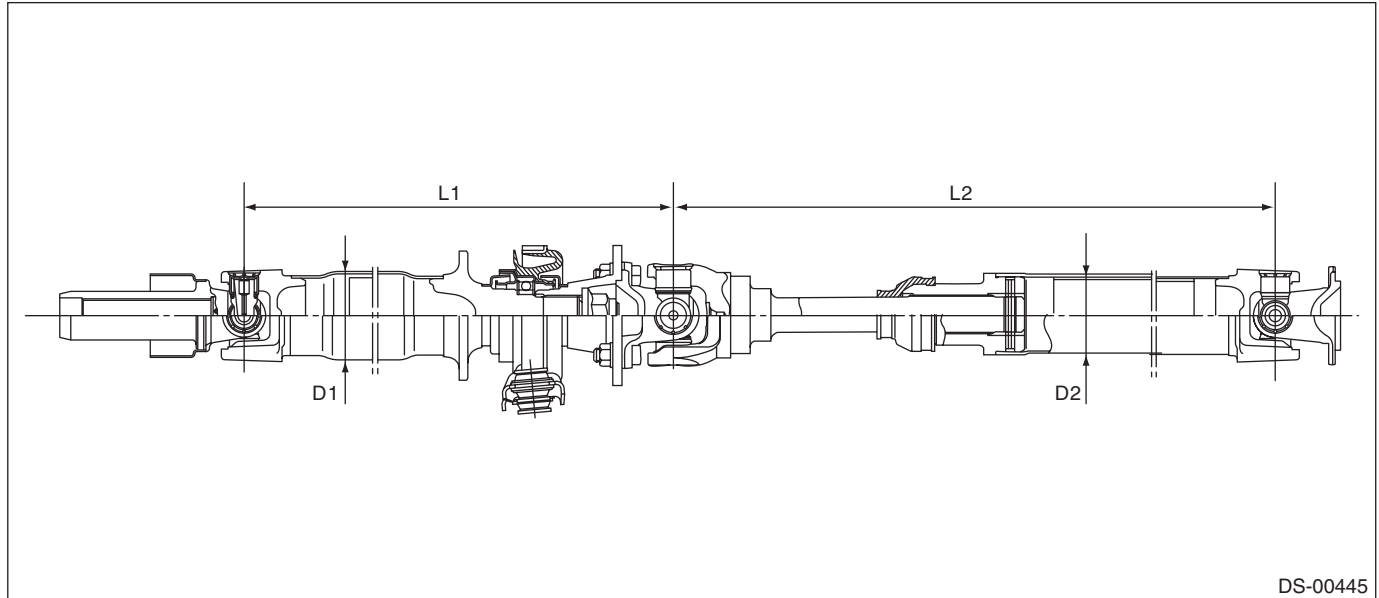

DS-00445

##### 2. FRONT DRIVE SHAFT ASSEMBLY

Model	Type of drive shaft	Axle diameter $\phi$ D mm (in)	Axle length L mm (in)
All models	AC + AAR	28 (1.10)	343.1 (13.51)

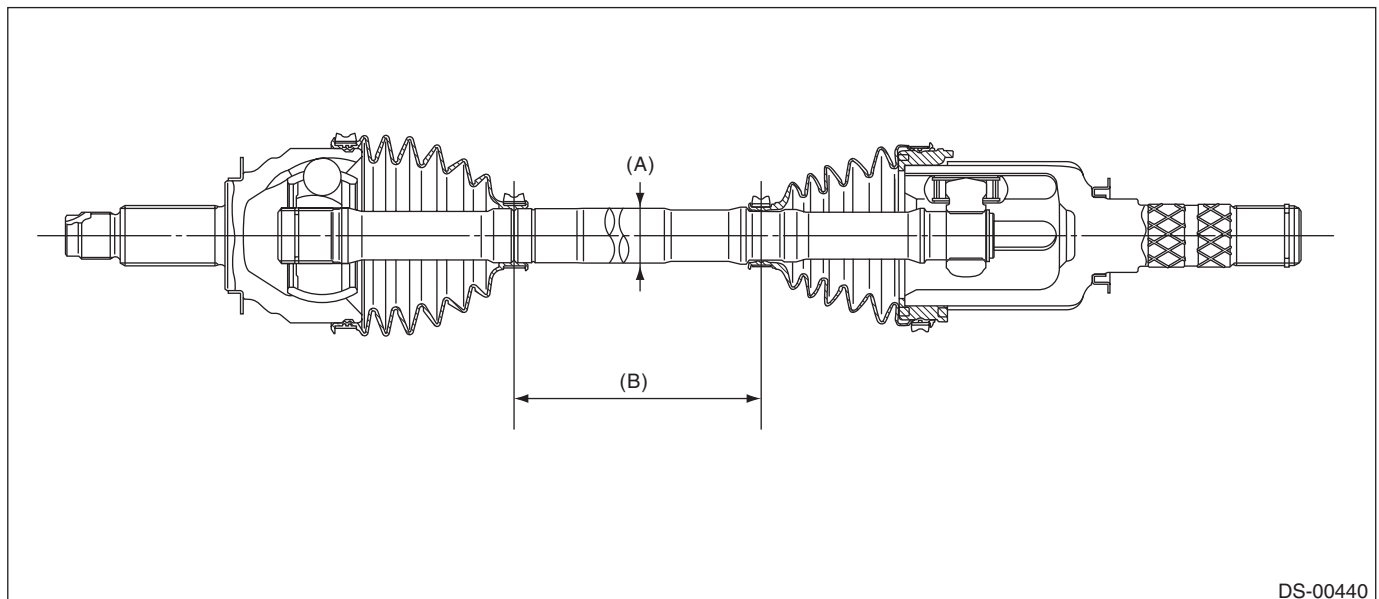

DS-00440

(A) Axle diameter

(B) Axle length

Brought to you by  
NOT FOR SALE  
Ergis Studios

### 3. REAR DRIVE SHAFT ASSEMBLY

Model	Type of drive shaft	Axle diameter $\phi$ D mm (in)	Axle length L mm (in)
All models	EBJ+EDJ	25 (0.98)	335.3 (13.20)

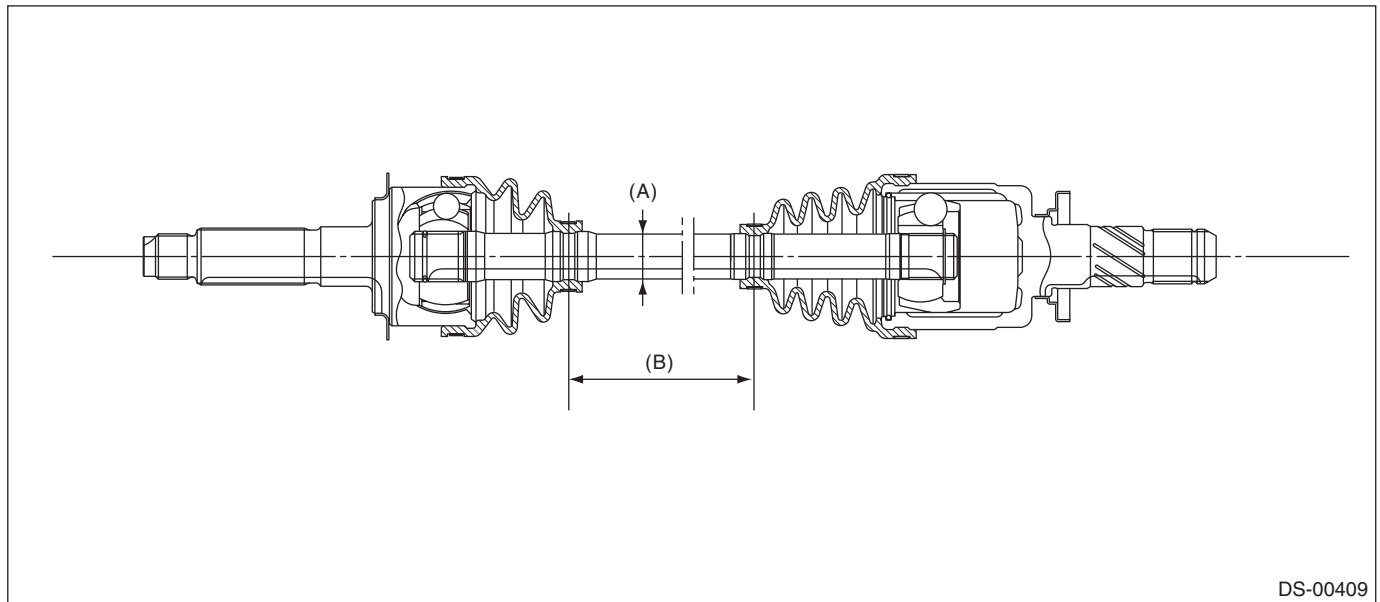

DS-00409

(A) Axle diameter

(B) Axle length

# General Description

Brought to you by Eris Studios  
NOT FOR RESALE

## DRIVE SHAFT SYSTEM

### B: COMPONENT

#### 1. PROPELLER SHAFT

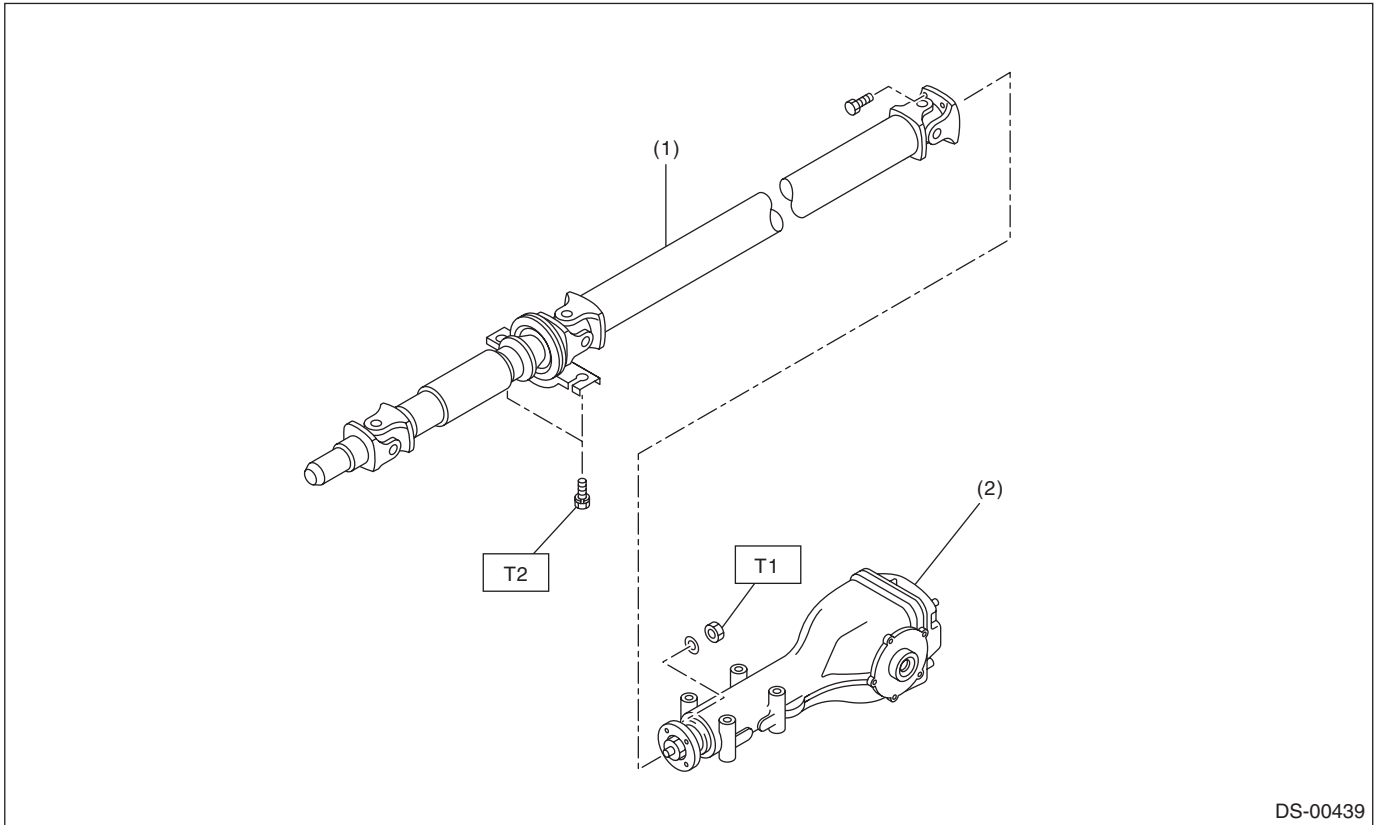

DS-00439

- (1) Propeller shaft (3UJ type)
- (2) Rear differential (T-type)

**Tightening torque: N·m (kgf·m, ft·lb)**

**T1: 31 (3.2, 23.1)**

**T2: 52 (5.3, 38.3)**

Brought to you by  
 NOT FOR SALE  
 Chris Studios

### 2. FRONT AXLE

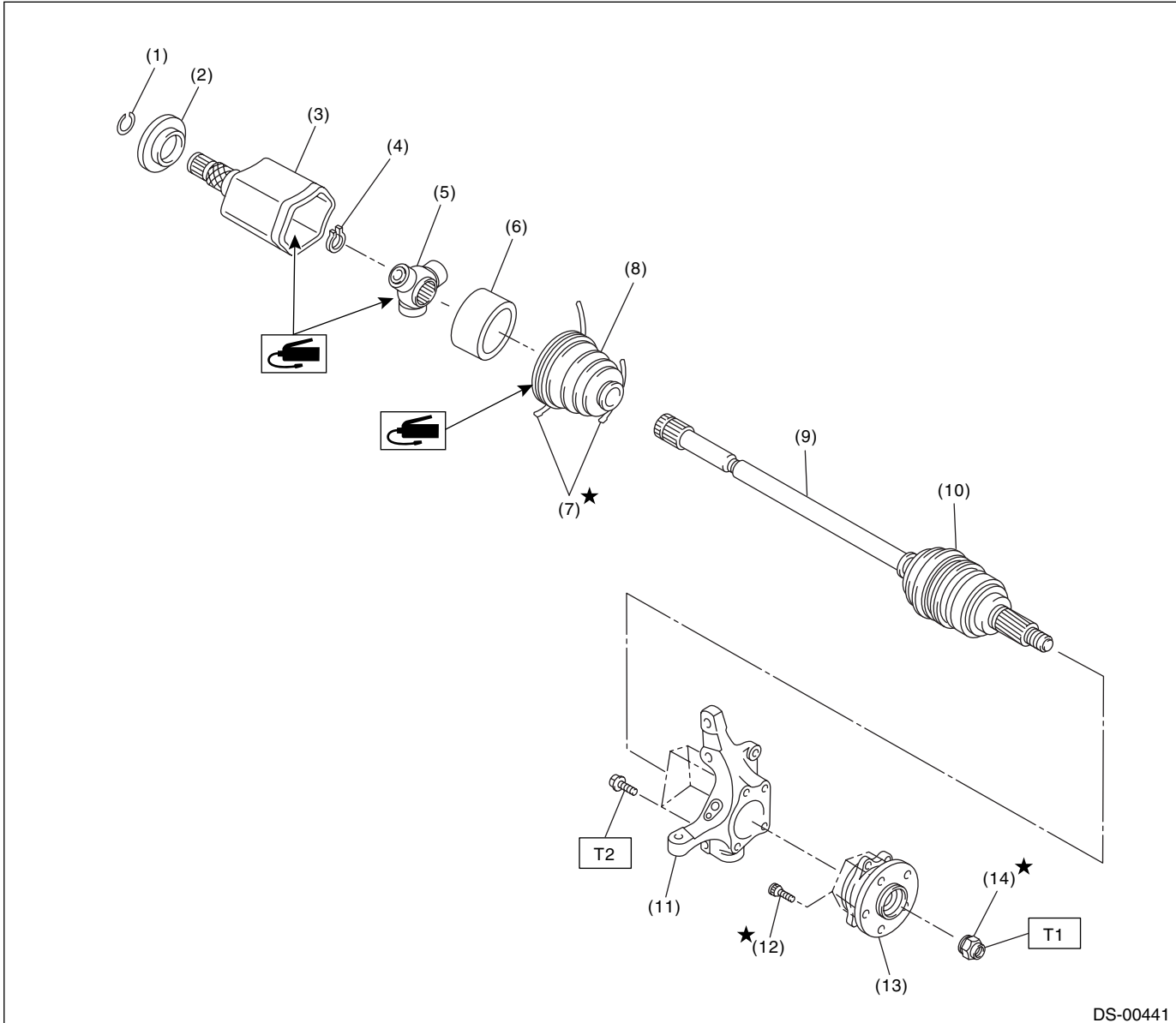

DS-00441

- |                      |                   |                             |
|----------------------|-------------------|-----------------------------|
| (1) Circlip          | (7) Boot band     | (13) Front hub unit bearing |
| (2) Baffle plate     | (8) Boot (AAR)    | (14) Axle nut               |
| (3) Outer race (AAR) | (9) AC shaft ASSY |                             |
| (4) Snap ring        | (10) Boot (AC)    |                             |
| (5) Trunnion         | (11) Housing      |                             |
| (6) Grommet          | (12) Hub bolt     |                             |

**Tightening torque: N·m (kgf·m, ft·lb)**

**T1: 220 (22.4, 162)**

**T2: 65 (6.6, 47.9)**

# General Description

## DRIVE SHAFT SYSTEM

Brought to you by Eris Studios  
NOT FOR RESALE

### 3. REAR AXLE

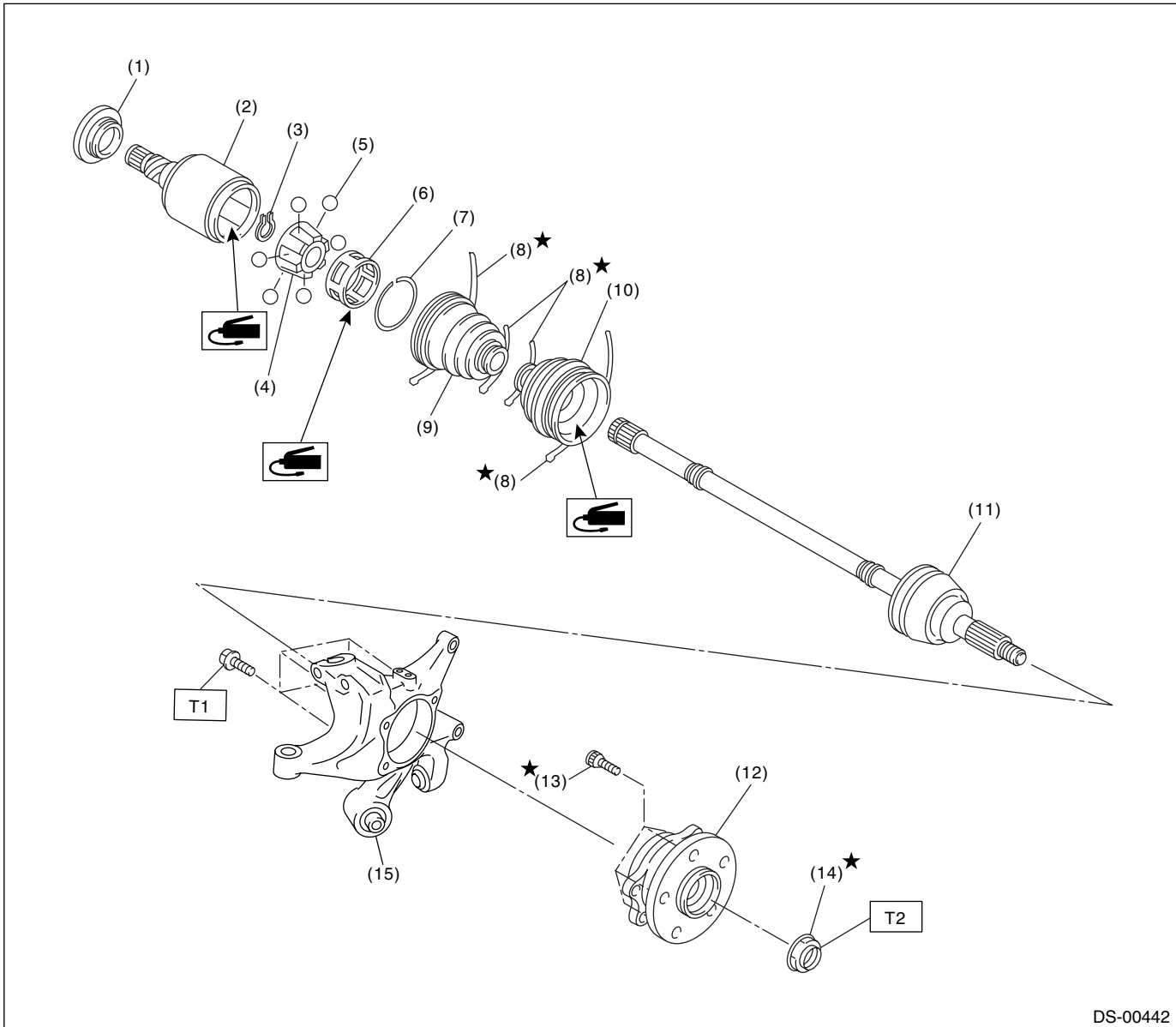

DS-00442

- |                      |                            |                        |
|----------------------|----------------------------|------------------------|
| (1) Baffle plate     | (8) Boot band              | (15) Rear axle housing |
| (2) Outer race (EDJ) | (9) Boot (EDJ)             |                        |
| (3) Snap ring        | (10) Boot (EBJ)            |                        |
| (4) Inner race       | (11) EBJ shaft ASSY        |                        |
| (5) Ball             | (12) Rear hub unit bearing |                        |
| (6) Cage             | (13) Hub bolt              |                        |
| (7) Snap ring        | (14) Axle nut              |                        |

**Tightening torque: N·m (kgf·m, ft·lb)**

**T1: 65 (6.6, 47.9)**

**T2: 190 (19.4, 140)**

### **C: CAUTION**

- Wear appropriate work clothing, including a cap, protective goggles and protective shoes when performing any work.
- Remove contamination including dirt and corrosion before removal, installation or disassembly.
- Keep the disassembled parts in order and protect them from dust and dirt.
- Before removal, installation or disassembly, be sure to clarify the failure. Avoid unnecessary removal, installation, disassembly and replacement.
- Vehicle components are extremely hot after driving. Be wary of receiving burns from heated parts.
- Use SUBARU genuine grease etc. or equivalent. Do not mix grease etc. of different grades or manufacturers.
- Be sure to tighten fasteners including bolts and nuts to the specified torque.
- Place shop jacks or rigid racks at the specified points.
- Apply grease onto sliding or revolving surfaces before installation.
- Before installing snap rings, apply sufficient amount of grease to avoid damage and deformation.
- Before securing a part on a vise, place cushioning materials such as wood blocks, aluminum plates, or waste cloth between the part and the vise.

# General Description

## DRIVE SHAFT SYSTEM

Brought to you by Eris Studios  
NOT FOR RESALE

### D: PREPARATION TOOL

#### 1. SPECIAL TOOL

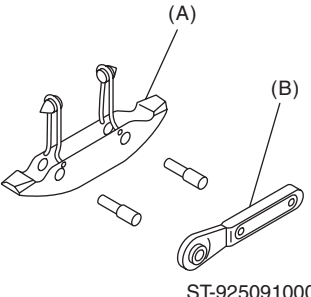
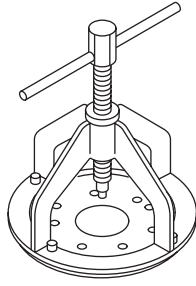
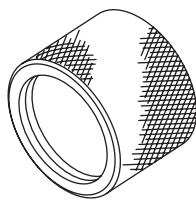
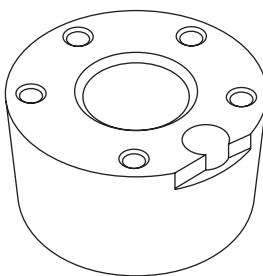
ILLUSTRATION	TOOL NUMBER	DESCRIPTION	REMARKS
 <p>ST-925091000</p>	925091000	BAND TIGHTENING TOOL	Used for tightening the boot band. (A) Jig for the band (B) Ratchet wrench
 <p>ST-926470000</p>	926470000	AXLE SHAFT PULLER	<ul style="list-style-type: none"> <li>Used for removing the axle shaft.</li> <li>Used together with AXLE SHAFT PULLER PLATE (28099PA110).</li> </ul>
 <p>ST18675AA000</p>	18675AA000	DIFFERENTIAL SIDE OIL SEAL INSTALLER	Used for installing the differential side retainer oil seal.
 <p>ST28099PA080</p>	28099PA080	HUB STAND	Used for assembling hub bolt in hub.



# General Description

## DRIVE SHAFT SYSTEM

Brought to you by *Meris Studios*  
NOT FOR SALE

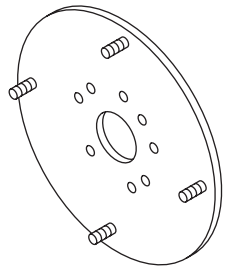
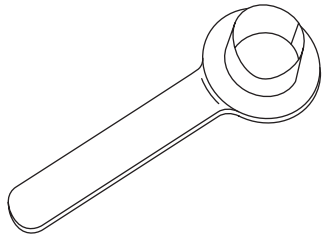
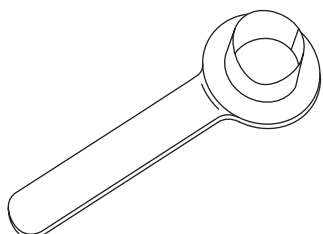
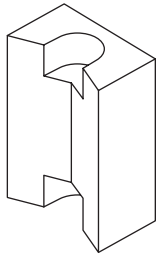
ILLUSTRATION	TOOL NUMBER	DESCRIPTION	REMARKS
 <p>ST28099PA110</p>	28099PA110	AXLE SHAFT PULLER PLATE	Exchange with the plate of the AXLE SHAFT PULLER (926470000) to use.
 <p>ST28099PA090</p>	28099PA090	OIL SEAL PROTECTOR	<ul style="list-style-type: none"> <li>• Used for installing the rear drive shaft to the rear differential.</li> <li>• For protecting the oil seal.</li> </ul>
 <p>ST28399SA010</p>	28399SA010	OIL SEAL PROTECTOR	<ul style="list-style-type: none"> <li>• Used for installing front drive shaft into front differential.</li> <li>• For protecting the oil seal.</li> </ul>
 <p>ST28399AG000</p>	28399AG000	HUB STAND	Used for extracting hub bolt.

## 2. GENERAL TOOL

TOOL NAME	REMARKS
Puller	Used for removing the ball joint from knuckle arm.
Dial gauge	Used for inspecting the propeller shaft run-out.
Extension cap	Used for preventing leakage of gear oil or ATF.
Bar	Used for extracting drive shaft.

# Propeller Shaft

## DRIVE SHAFT SYSTEM

Brought to you by Eris Studios  
NOT FOR RESALE

## 2. Propeller Shaft

### A: REMOVAL

- 1) Disconnect the ground cable from the battery.
- 2) Shift the select lever or gear shift lever to neutral.
- 3) Release the parking brake.
- 4) Lift up the vehicle.
- 5) Remove the center exhaust pipe.
- 6) Remove the rear exhaust pipe and muffler.
- 7) Remove the heat shield cover.

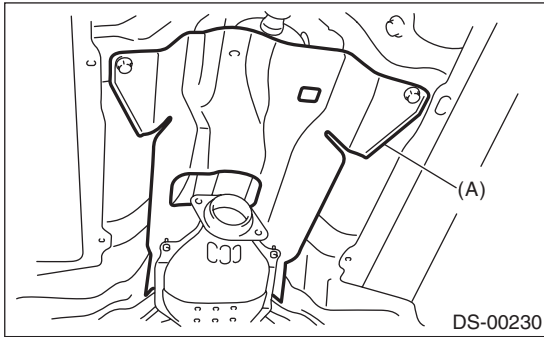

(A) Heat shield cover

- 8) Make alignment marks on the flange yoke and rear differential before removal.

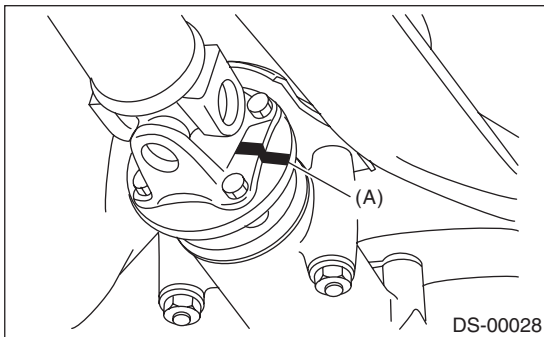

(A) Alignment mark

- 9) Remove the three bolts holding the propeller shaft to the rear differential.
- 10) Remove the remaining bolt.
- 11) Remove the two bolts which hold center bearing to vehicle body.

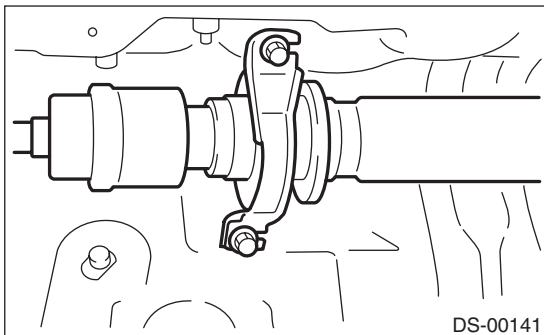

- 12) Remove the propeller shaft from transmission.

### CAUTION:

- Be careful not to damage oil seals and contact surface of the sleeve yoke.
- Cover the center exhaust pipe with a cloth to keep off any oil spilled from transmission when removing propeller shaft.

### NOTE:

Use a container to catch oil flowing from propeller shaft.

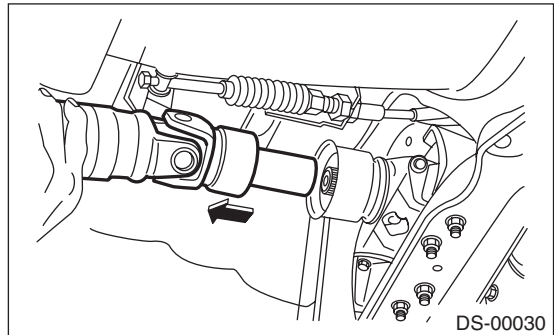

- 13) Install an extension cap to the transmission.

### NOTE:

If extension cap is not available, place vinyl bag over opening and fasten with string to prevent gear oil from leaking.

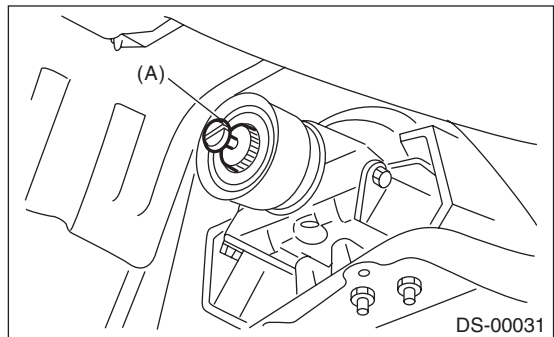

(A) Extension cap

Brought to you by *Chris Studios*  
 NOT FOR SALE

## B: INSTALLATION

1) Insert the sleeve yoke into the transmission and attach center bearing to body.

**Tightening torque:**

**52 N·m (5.3 kgf-m, 38.3 ft-lb)**

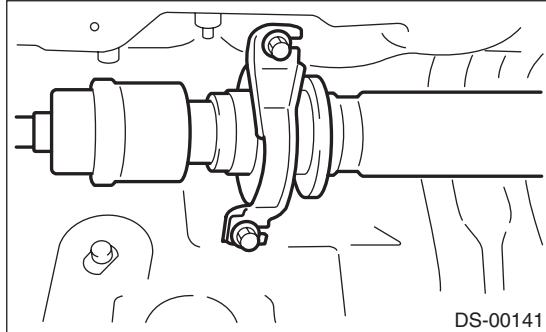

2) Align the alignment marks and connect the flange yoke and rear differential.

**Tightening torque:**

**31 N·m (3.2 kgf-m, 23.1 ft-lb)**

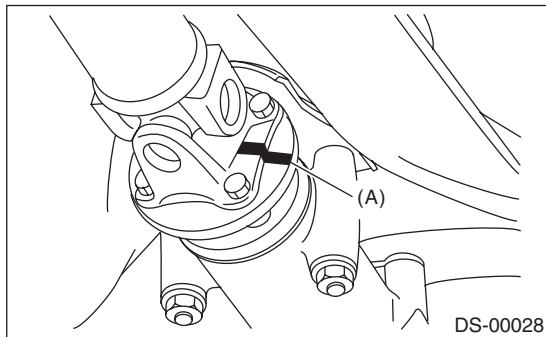

(A) Alignment mark

- 3) Install the heat shield cover.
- 4) Install the center exhaust pipe.
- 5) Install the rear exhaust pipe and muffler.
- 6) Lower the vehicle.
- 7) Connect the ground cable to the battery.

## C: INSPECTION

**NOTE:**

Do not disassemble propeller shaft. Check the following and replace if necessary.

- Dents or cracks on the tube surface
- Splines for deformation or abnormal wear
- Unsmooth joint operation or abnormal noise
- Center bearing for free play, noise or non-smooth operation.
- Oil seals for abnormal wear or damage
- Damaged center bearing

Check the following points with propeller shaft installed in vehicle.

### 1. JOINTS AND CONNECTORS

- 1) Remove the center exhaust pipe.
- 2) Remove the heat shield cover.
- 3) Check for any looseness of the yoke flange mounting bolts which connect to the rear differential and center bearing bracket mounting bolts.

### 2. SPLINES AND BEARING

- 1) Remove the center exhaust pipe.
- 2) Remove the rear exhaust pipe and muffler.
- 3) Remove the heat shield cover.
- 4) Turn the propeller shaft by hand to see if abnormal free play exists at splines. Also move yokes to see if abnormal free play exists at spiders and bearings.

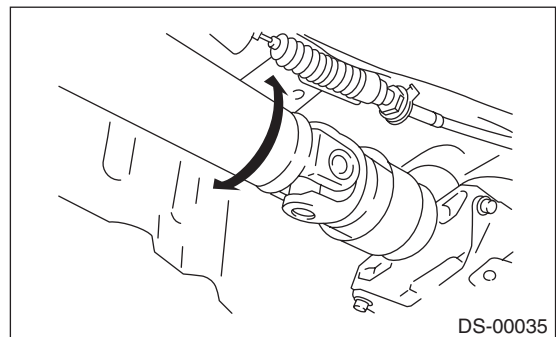

### 3. RUNOUT OF PROPELLER SHAFT

- 1) Remove the center exhaust pipe.
- 2) Remove the rear exhaust pipe and muffler.
- 3) Remove the heat shield cover.
- 4) Set the dial gauge with its indicator stem at the center of the propeller shaft tube.
- 5) Turn the propeller shaft slowly by hands to check for runout of the propeller shaft.

#### **Runout:**

**Limit: 0.6 mm (0.024 in)**

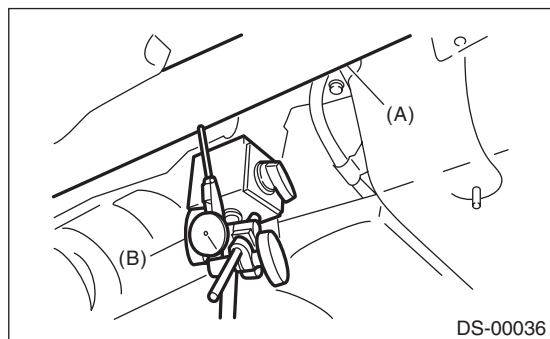

- (A) Propeller shaft
- (B) Dial gauge

### 4. CENTER BEARING FREE PLAY

- 1) Remove the front and center exhaust pipes.
- 2) Remove the rear exhaust pipe and muffler.
- 3) Remove the heat shield cover.
- 4) Move the propeller shaft near the center bearing up, down, left, right by hand, to check for any abnormal free play of the bearings.

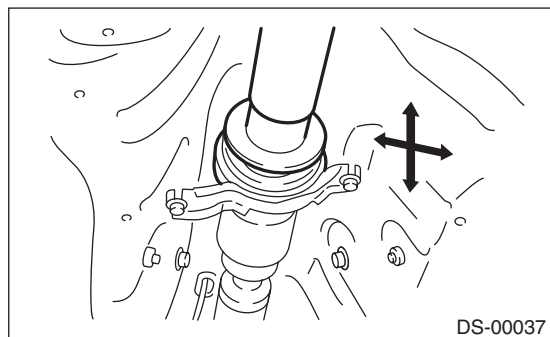

Brought to you by *Chris Studios*  
 NOT FOR SALE

### 3. Front Axle

#### A: REMOVAL

- 1) Disconnect the ground cable from the battery.
- 2) Lift up the vehicle, and remove the front wheels.
- 3) Lift the crimped section of axle nut.

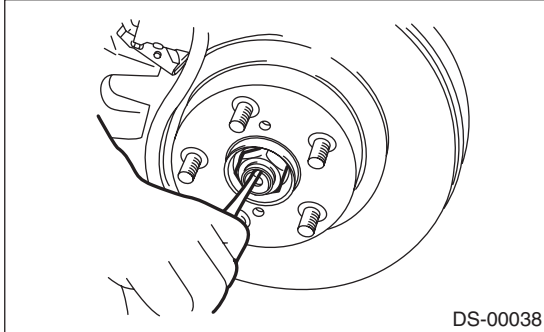

- 4) Remove the axle nut using a socket wrench while depressing the brake pedal.

#### CAUTION:

**Remove the wheel before loosening the axle nut. Failure to follow this rule may damage the wheel bearings.**

- 5) Remove the stabilizer link.

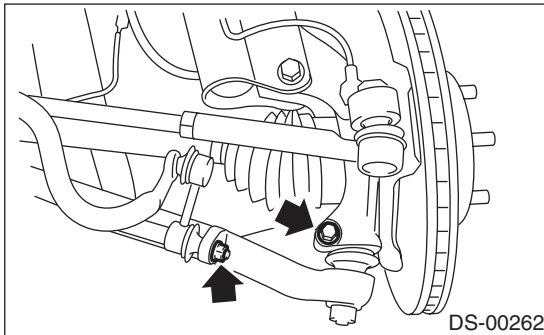

- 6) Remove the disc brake caliper from the housing, and suspend it from strut using a wire.
- 7) Remove the disc rotor from the hub.

#### NOTE:

If it is difficult to remove the disc rotor from the hub, drive the 8 mm bolt into the threaded end of rotor, and then remove the rotor.

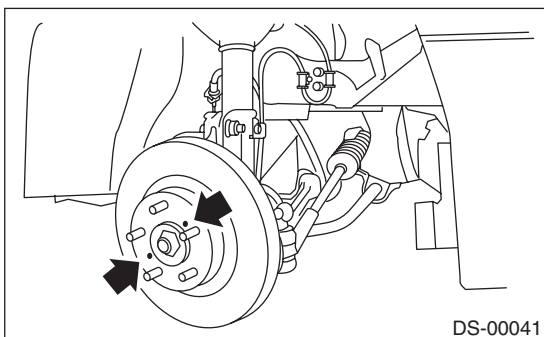

- 8) Remove the cotter pin and castle nut securing the tie-rod end to the housing knuckle arm.

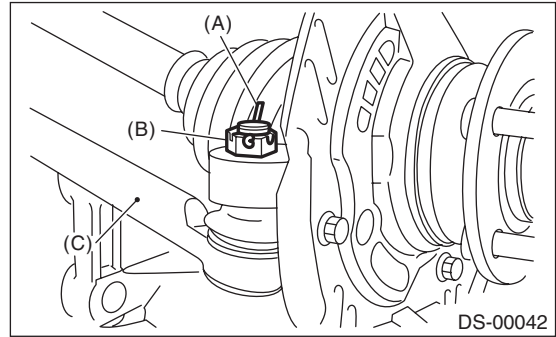

- (A) Cotter pin
- (B) Castle nut
- (C) Tie-rod

- 9) Using a puller, remove the tie-rod ball joint from knuckle arm.

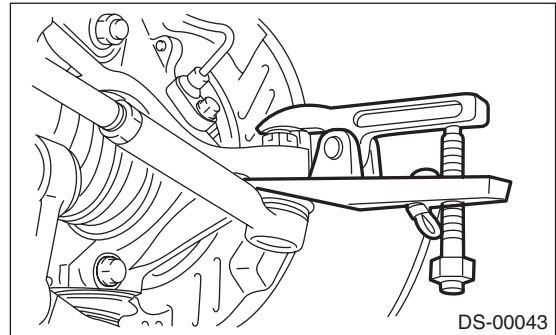

- 10) Remove the ABS wheel speed sensor assembly and harness.

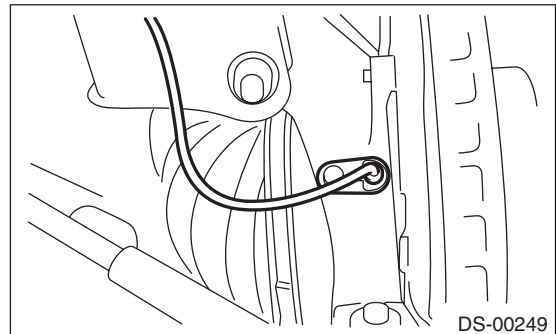

- 11) Remove the bolts which secure the sensor harness to the strut.

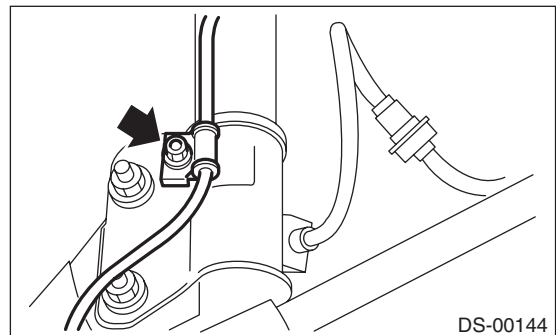

## DRIVE SHAFT SYSTEM

- 12) Remove the front arm ball joint from the housing.

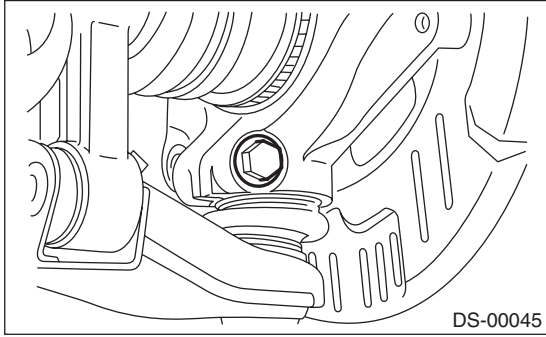

- 13) Remove the front drive shaft from the transmission.

- 14) Remove the front drive shaft assembly from the hub. If it is hard to remove, use the ST.

ST1	926470000	AXLE SHAFT PULLER
ST2	28099PA110	AXLE SHAFT PULLER PLATE

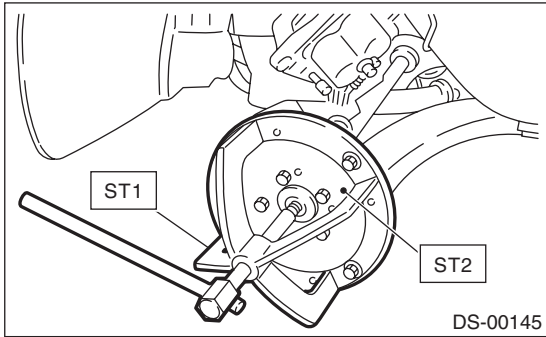

- 15) After scribing an alignment mark on camber adjusting bolt head, remove the bolts which connect the housing and strut, and disconnect the housing from strut.

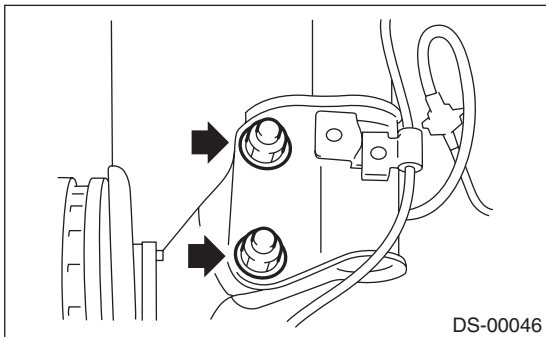

## B: INSTALLATION

- 1) Align the alignment mark on the camber adjusting bolt head, and tighten the housing and strut using a new self-locking nut.

### Tightening torque:

**175 N·m (17.8 kgf-m, 129 ft-lb)**

- 2) Install the front drive shaft. <Ref. to DS-25, INSTALLATION, Front Drive Shaft.>

- 3) Install the front arm ball joint to the housing.

### Tightening torque:

**50 N·m (5.1 kgf-m, 36.9 ft-lb)**

- 4) Install the ABS sensor harness to the strut.

- 5) Install the ABS wheel speed sensor on the housing.

### Tightening torque:

**7.5 N·m (0.76 kgf-m, 5.5 ft-lb)**

- 6) Install the disc rotor to hub.

- 7) Install the disc brake caliper on the housing.

### Tightening torque:

**155 N·m (15.8 kgf-m, 114.3 ft-lb)**

- 8) Install the stabilizer link.

- 9) Connect the tie-rod end ball joint to the knuckle arm with a castle nut.

### Tightening torque:

**27.0 N·m (2.75 kgf-m, 19.9 ft-lb)**

### CAUTION:

**When connecting the tie-rod, do not hit the cap at bottom of tie-rod end with a hammer.**

- 10) Tighten the castle nut to specified torque and tighten further within 60° until the pin hole is aligned with the slot in the nut. Bend the cotter pin to lock.

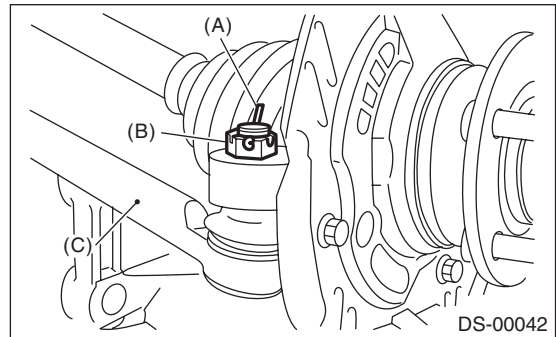

- (A) Cotter pin  
(B) Castle nut  
(C) Tie-rod

Brought to you by  
 NOT FOR SALE  
 Chris Studios

11) While depressing the brake pedal, tighten a new axle nut to the specified torque and lock it securely.

**Tightening torque:**

**220 N·m (22.4 kgf·m, 162 ft·lb)**

**CAUTION:**

- Do not install wheel and let it touch the ground before tightening the axle nut. Failure to follow this rule may damage the axle bearing.
- Do not overtighten the nuts as this may damage the axle bearing.

12) After tightening the axle nut, lock it securely.

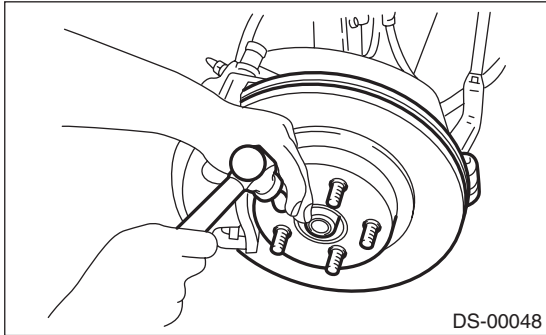

13) Install the wheel.

**Tightening torque:**

**100 N·m (10.2 kgf·m, 73.8 ft·lb)**

14) Connect the battery ground cable to the battery.

15) Inspect the wheel alignment and adjust if necessary.

### C: DISASSEMBLY

1) Remove the four bolts from the housing, and remove the front hub unit bearing and disc cover.

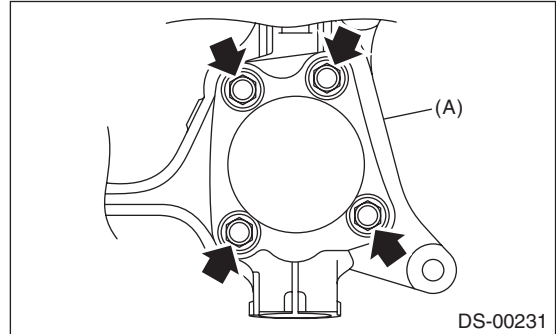

(A) Housing

**CAUTION:**

- Do not get closer the tool which charged magnetism to magnetic encoder.
- Be careful not to damage the magnetic encoder.

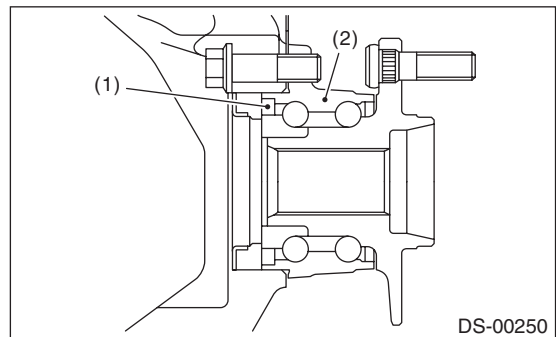

(1) Magnetic encoder

(2) Front hub unit bearing

2) Disassemble the front hub unit bearing. <Ref. to DS-18, DISASSEMBLY, Front Hub Unit Bearing.>

## DRIVE SHAFT SYSTEM

### D: ASSEMBLY

- 1) Assemble the front hub unit bearing. <Ref. to DS-18, ASSEMBLY, Front Hub Unit Bearing.>
- 2) Place the disc cover between housing and front hub unit, and tighten the four bolts.

#### Tightening torque:

**65 N·m (6.6 kgf-m, 47.9 ft-lb)**

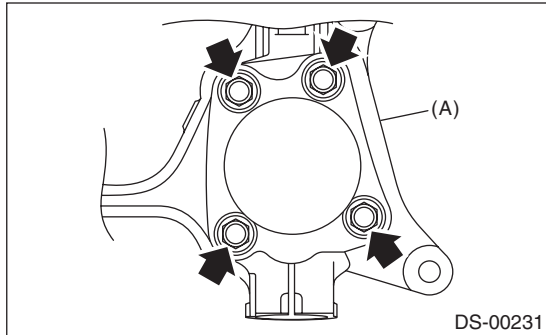

(A) Housing

#### CAUTION:

- Do not get closer the tool which charged magnetism to magnetic encoder.
- Be careful not to damage the magnetic encoder.

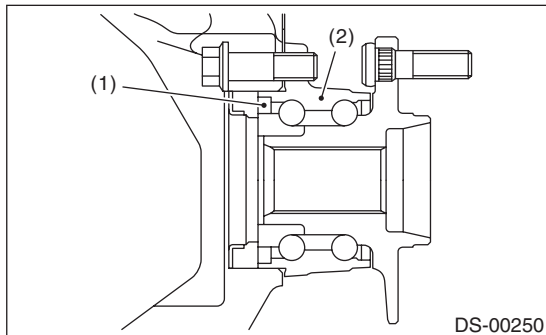

- (1) Magnetic encoder
- (2) Front hub unit bearing

### E: INSPECTION

- 1) Moving the front tire up and down by hand, check there is no play in bearing, and check the wheel rotates smoothly.

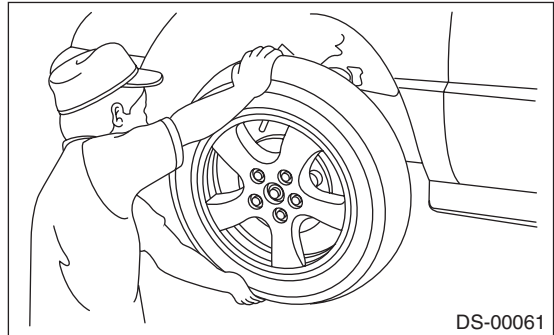

- 2) Inspect the lean of axis direction using a dial gauge. Replace the bearing if the load range exceeds the limitation.

#### Service limit:

**Maximum: 0.05 mm (0.0020 in)**

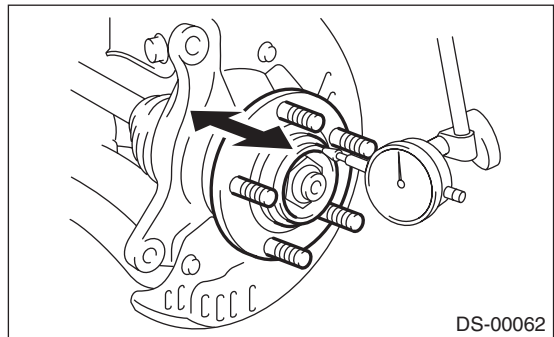



Brought to you by *Chris Studios*  
NOT FOR SALE

## 4. Front Hub Unit Bearing

### A: REMOVAL

- 1) Disconnect the ground cable from the battery.
- 2) Lift up the vehicle, and remove the front wheels.
- 3) Lift the crimped section of axle nut.

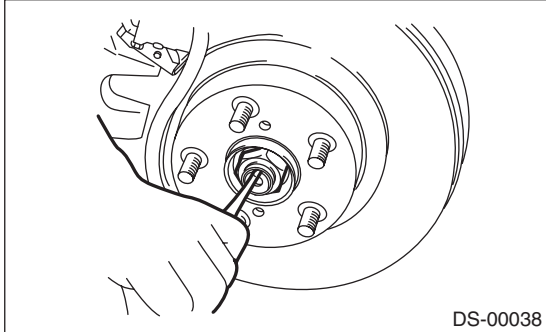

- 4) Remove the axle nut using a socket wrench while depressing the brake pedal.

#### CAUTION:

**Remove the wheel before loosening the axle nut. Failure to follow this rule may damage the wheel bearings.**

- 5) Remove the disc brake caliper from the housing, and suspend it from strut using a wire.
- 6) Remove the disc rotor from the hub.

#### NOTE:

If it is difficult to remove the disc rotor from the hub, drive the 8 mm bolt into the threaded end of rotor, and then remove the rotor.

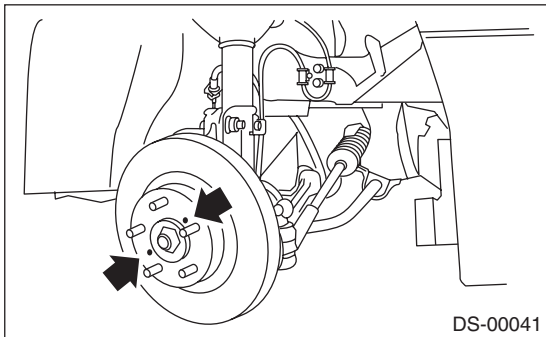

- 7) Remove the four bolts from the housing.

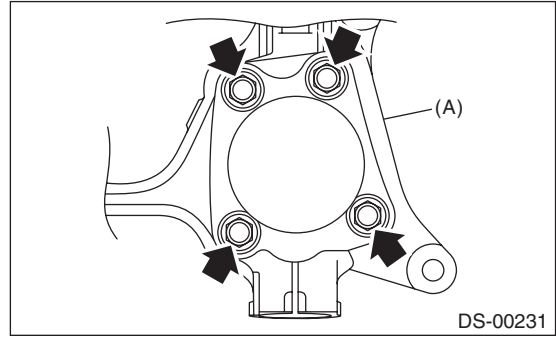

(A) Housing

#### CAUTION:

- Do not get closer the tool which charged magnetism to magnetic encoder.
- Be careful not to damage the magnetic encoder.

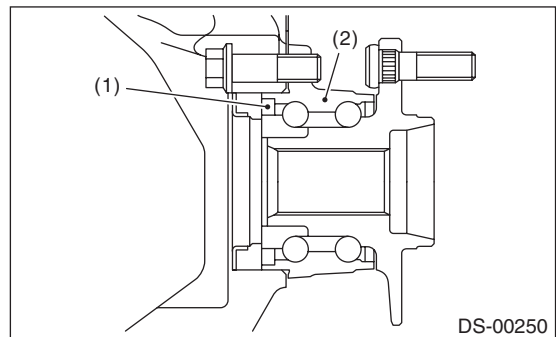

(1) Magnetic encoder  
(2) Front hub unit bearing

- 8) Remove the front hub unit bearing. If it is hard to remove, use the ST.

ST1 926470000 AXLE SHAFT PULLER  
ST2 28099PA110 AXLE SHAFT PULLER PLATE

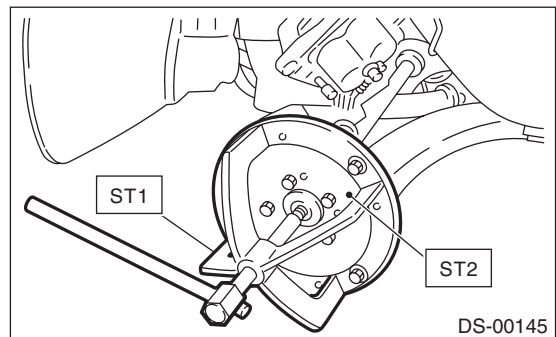

## DRIVE SHAFT SYSTEM

### B: INSTALLATION

1) Place the disc cover between housing and front hub unit, and tighten the four bolts.

**Tightening torque:**

**65 N·m (6.6 kgf·m, 47.9 ft-lb)**

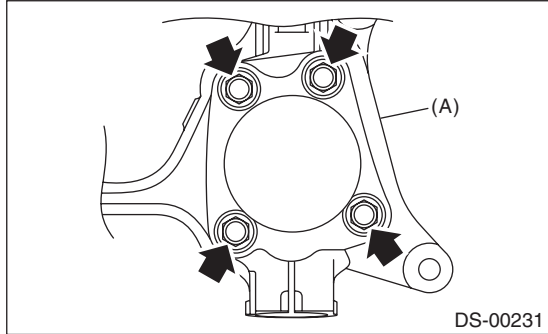

(A) Housing

2) Install the front drive shaft. <Ref. to DS-25, INSTALLATION, Front Drive Shaft.>

3) Tighten the axle nut temporarily.

4) Install the disc rotor to hub.

5) Install the disc brake caliper on the housing.

**Tightening torque:**

**155 N·m (15.8 kgf·m, 114.3 ft-lb)**

6) While depressing the brake pedal, tighten a new axle nut to the specified torque and lock it securely.

**Tightening torque:**

**220 N·m (22.4 kgf·m, 162 ft-lb)**

**CAUTION:**

- Do not install wheel and let it touch the ground before tightening the axle nut. Failure to follow this rule may damage the axle bearing.
- Do not overtighten the nuts as this may damage the axle bearing.

7) After tightening the axle nut, lock it securely.

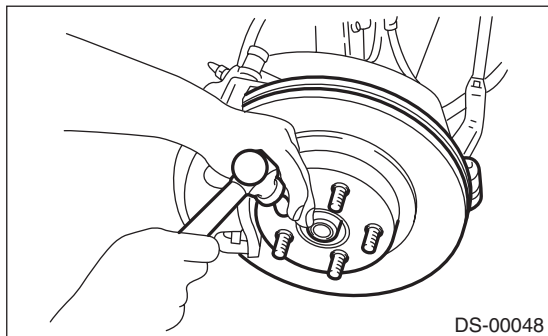

8) Install the wheel.

**Tightening torque:**

**100 N·m (10.2 kgf·m, 73.8 ft-lb)**

### C: DISASSEMBLY

Using the ST and a hydraulic press, push out the hub bolts.

ST 28399AG000 HUB STAND

**CAUTION:**

- Be careful not to hammer the hub bolts. This may deform the hub.
- Do not reuse the hub bolt.

**NOTE:**

Since the hub unit bearing can not be disassembled, only hub bolts can be removed.

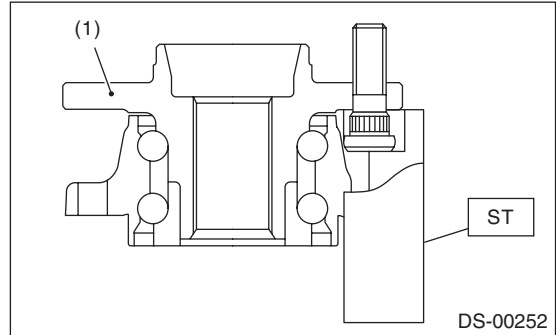

(1) Front hub unit bearing

### D: ASSEMBLY

1) Attach the hub to the ST securely.

ST 28099PA080 HUB STAND

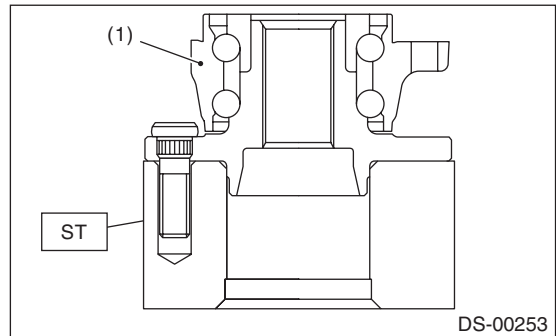

(1) Front hub unit bearing

2) Using a press, press the new hub bolts until their seating surfaces contact the hub.

**NOTE:**

Use the 12 mm (0.47 in) dia. holes in the HUB STAND to prevent bolts from tilting.

### E: INSPECTION

Refer to "Front Axle" for inspection procedures. <Ref. to DS-16, INSPECTION, Front Axle.>

**CAUTION:**

If there is any fault in the bearing, replace hub unit bearing.

Brought to you by *Chris Studios*  
NOT FOR SALE

## 5. Rear Axle

### A: REMOVAL

- 1) Disconnect the ground cable from the battery.
- 2) Lift up the vehicle, and then remove the rear wheels.
- 3) Lift the crimped section of axle nut.

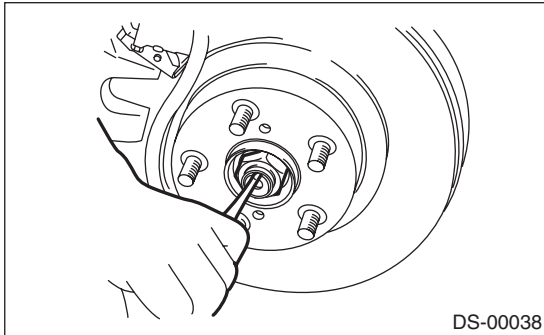

- 4) Remove the axle nut using a socket wrench while depressing the brake pedal.

**CAUTION:**

**Remove the wheel before loosening the axle nut. Failure to follow this rule may damage the wheel bearings.**

- 5) Remove the brake hose bracket and the rear ABS wheel speed sensor.

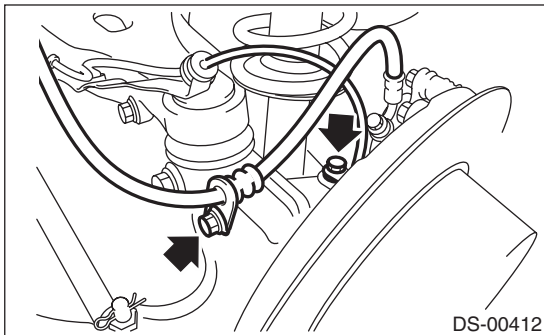

- 6) Remove the disc brake caliper from the rear housing, and suspend it from the vehicle using a string.

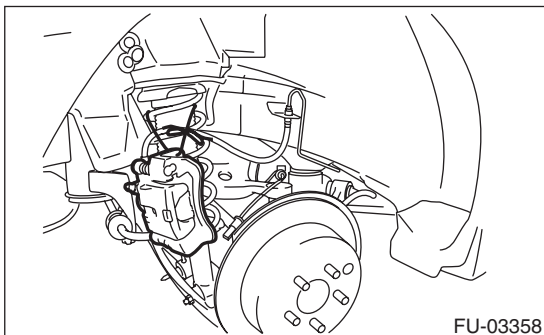

- 7) Remove the rear disc rotor.

- 8) Remove the four bolts from the rear housing.

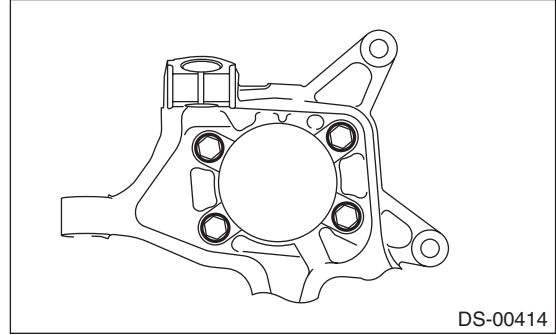

# Rear Axle

Brought to you by Eris Studios  
NOT FOR RESALE

## DRIVE SHAFT SYSTEM

9) Remove the rear hub unit bearing.

### CAUTION:

- Be careful not to damage the magnetic encoder.
- Do not get closer the tool which charged magnetism to magnetic encoder.

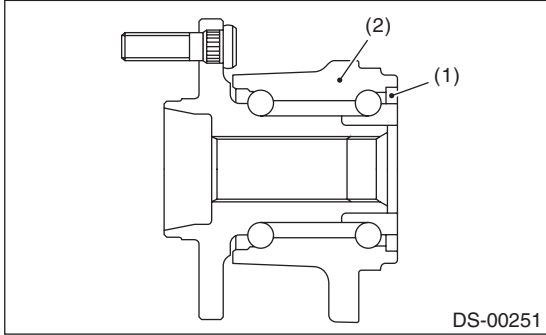

- (1) Magnetic encoder
- (2) Rear hub unit bearing

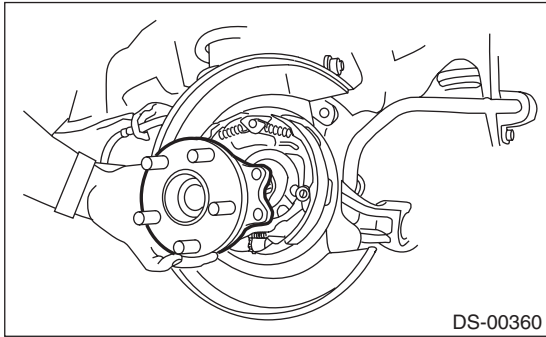

### NOTE:

If it is hard to remove, use the ST.

- ST1 926470000 AXLE SHAFT PULLER
- ST2 28099PA110 AXLE SHAFT PULLER PLATE

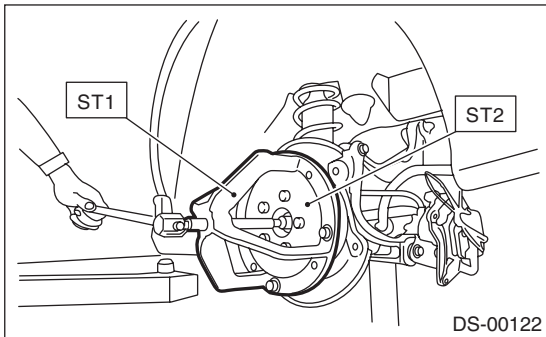

10) Remove the snap pin and nut from the front lateral link.

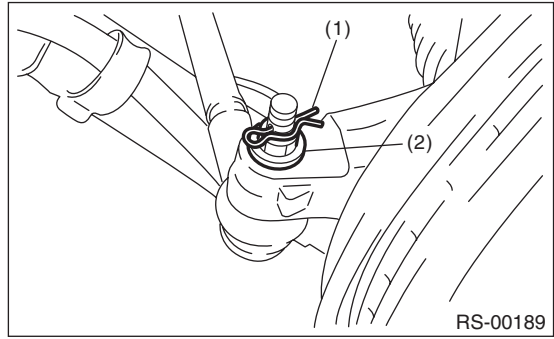

- (1) Snap pin
- (2) Nut

11) Using a puller, separate the rear housing and ball joint.

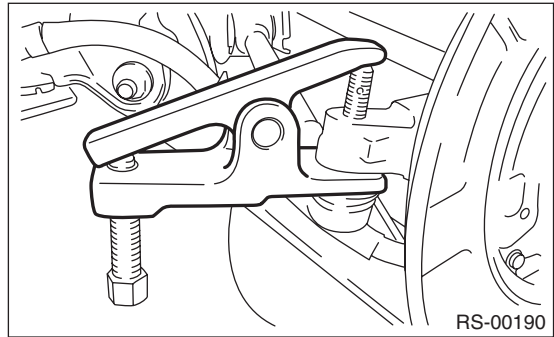

12) Separate the upper arm, trailing link, and rear lateral link from the rear housing.

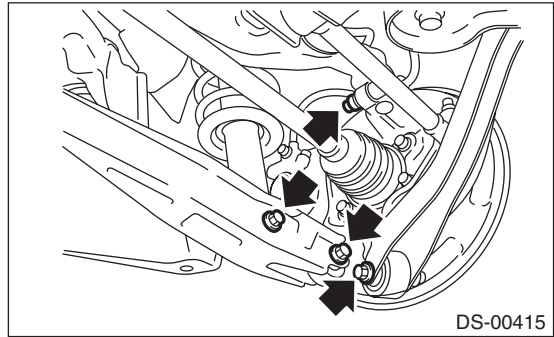

13) Remove the rear axle.

**B: INSTALLATION**

- 1) Temporarily tighten the rear housing to the upper arm.
- 2) Aligning with the mounting hole of the rear brake back plate, temporarily tighten the rear hub unit bearing to the rear housing.

**CAUTION:**

- Be careful not to damage the magnetic encoder.
- Do not get closer the tool which charged magnetism to magnetic encoder.

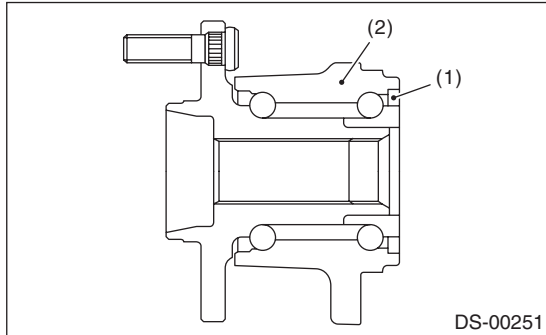

- (1) Magnetic encoder
- (2) Rear hub unit bearing

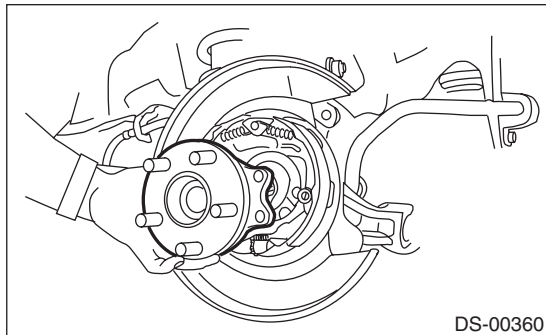

- 3) Attach the rear drive shaft to the rear hub unit bearing.
- 4) Tighten the new axle nut temporarily.
- 5) Attach the links to the rear housing and tighten them to the specified torque.

**Tightening torque:****Upper arm****90 N·m (9.2 kgf·m, 66.4 ft·lb)****Front lateral link****60 N·m (6.1 kgf·m, 44 ft·lb)****Rear lateral link****120 N·m (12.2 kgf·m, 89 ft·lb)****Trailing link****90 N·m (9.2 kgf·m, 66.4 ft·lb)**

- 6) Tighten the four bolts of the rear housing.

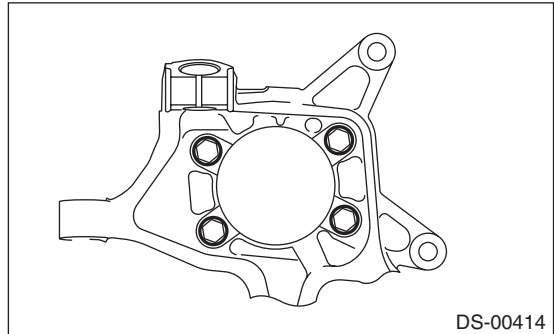
**Tightening torque:****65 N·m (6.6 kgf·m, 47.9 ft·lb)**

- 7) Install the rear disc rotor.
- 8) Install the rear disc brake caliper on the rear housing.

**Tightening torque:****65 N·m (6.6 kgf·m, 47.9 ft·lb)**

- 9) Install the brake hose bracket and rear ABS wheel speed sensor.

**Tightening torque:****Brake hose bracket****33 N·m (3.4 kgf·m, 24.3 ft·lb)****Rear ABS wheel speed sensor****7.5 N·m (0.76 kgf·m, 5.5 ft·lb)**

- 10) While pressing the brake pedal, tighten the new axle nuts to the specified torque.

**Tightening torque:****190 N·m (19.4 kgf·m, 140 ft·lb)****CAUTION:**

- Do not install wheel and let it touch the ground before tightening the axle nut. Failure to follow this rule may damage the axle bearing.
  - Do not overtighten the nuts as this may damage the axle bearing.
- 11) After tightening the axle nut, lock it securely.

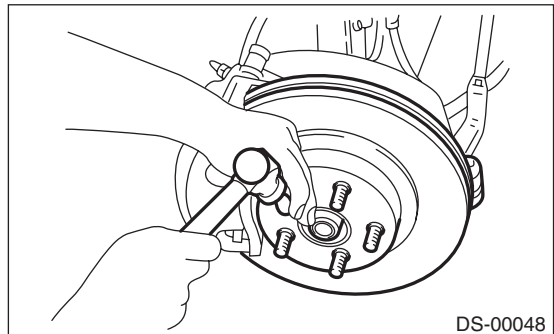

- 12) Install the rear wheels.

**Tightening torque:****100 N·m (10.2 kgf·m, 73.8 ft·lb)**

- 13) Connect the ground cable to the battery.
- 14) Inspect the wheel alignment and adjust if necessary.

## 6. Rear Hub Unit Bearing

### A: REMOVAL

- 1) Disconnect the ground cable from the battery.
- 2) Lift up the vehicle, and then remove the rear wheels.
- 3) Lift the crimped section of axle nut.

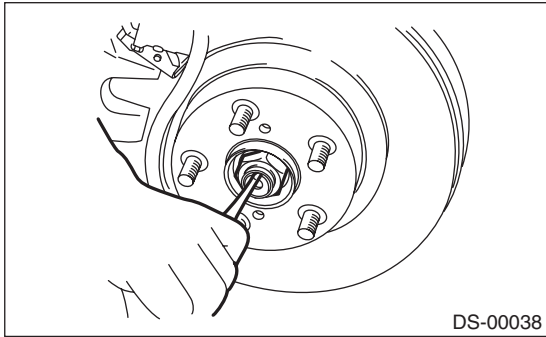

- 4) Remove the axle nut using a socket wrench while depressing the brake pedal.

#### CAUTION:

**Remove the wheel before loosening the axle nut. Failure to follow this rule may damage the wheel bearings.**

- 5) Remove the disc brake caliper from the rear housing, and suspend it from the vehicle using a string.

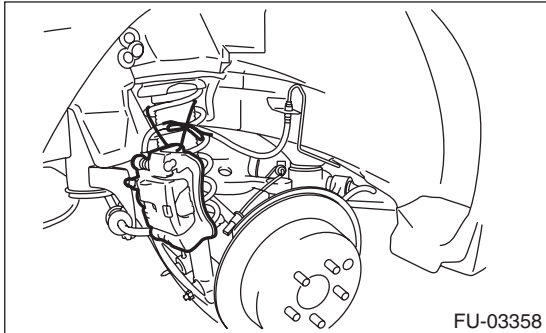

- 6) Remove the rear disc rotor.
- 7) Remove the four bolts from the rear housing.

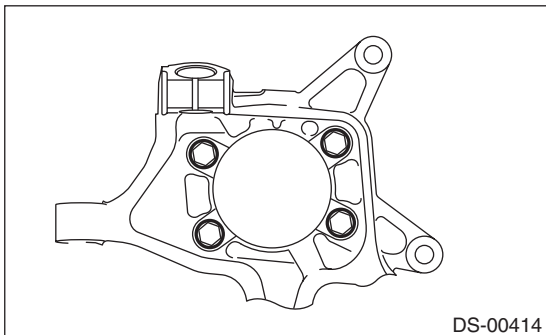

- 8) Remove the rear hub unit bearing.

#### CAUTION:

- Be careful not to damage the magnetic encoder.
- Do not get closer the tool which charged magnetism to magnetic encoder.

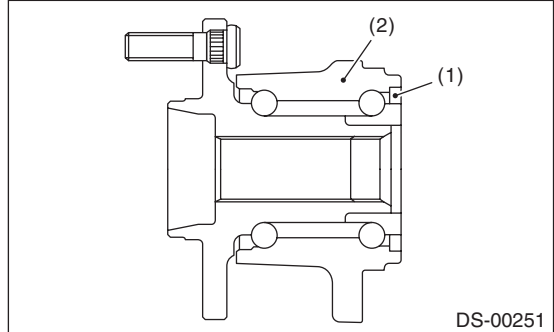

- (1) Magnetic encoder
- (2) Rear hub unit bearing

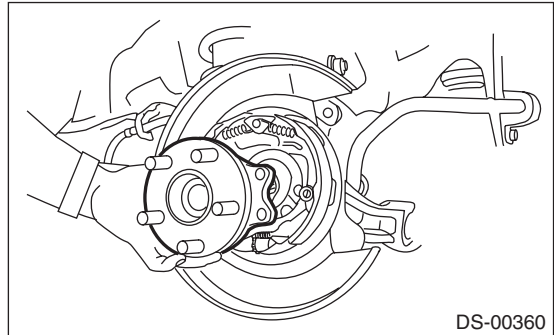

#### NOTE:

If it is hard to remove, use the ST.

- |     |            |                         |
|-----|------------|-------------------------|
| ST1 | 926470000  | AXLE SHAFT PULLER       |
| ST2 | 28099PA110 | AXLE SHAFT PULLER PLATE |

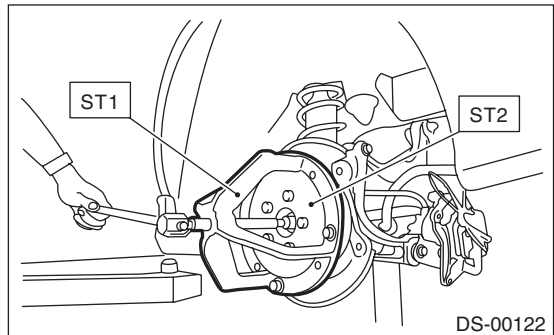

Brought to you by *Peris Studios*  
 NOT FOR SALE

## B: INSTALLATION

1) Aligning with the mounting hole of the rear brake back plate, temporarily tighten the rear hub unit bearing to the rear housing.

### CAUTION:

- Be careful not to damage the magnetic encoder.
- Do not get closer the tool which charged magnetism to magnetic encoder.

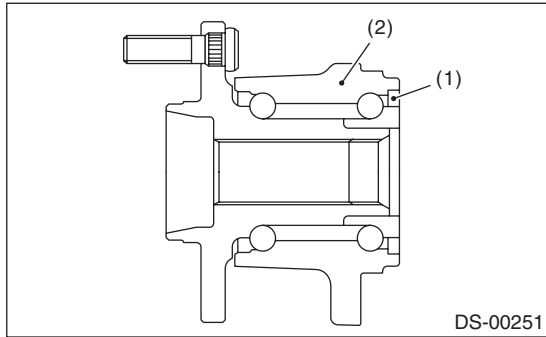

- (1) Magnetic encoder  
 (2) Rear hub unit bearing

2) Tighten the four bolts of the rear housing.

### Tightening torque:

**65 N·m (6.6 kgf·m, 47.9 ft·lb)**

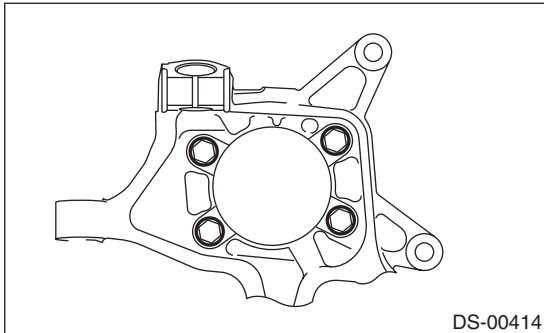

- 3) Tighten the new axle nut temporarily.  
 4) Install the rear disc rotor.  
 5) Install the disc brake caliper on the rear housing.

### Tightening torque:

**65 N·m (6.6 kgf·m, 47.9 ft·lb)**

6) While pressing the brake pedal, tighten the new axle nuts to the specified torque.

### Tightening torque:

**190 N·m (19.4 kgf·m, 140 ft·lb)**

### CAUTION:

- Do not install wheel and let it touch the ground before tightening the axle nut. Failure to follow this rule may damage the axle bearing.
- Do not overtighten the nuts as this may damage the axle bearing.

7) After tightening the axle nut, lock it securely.

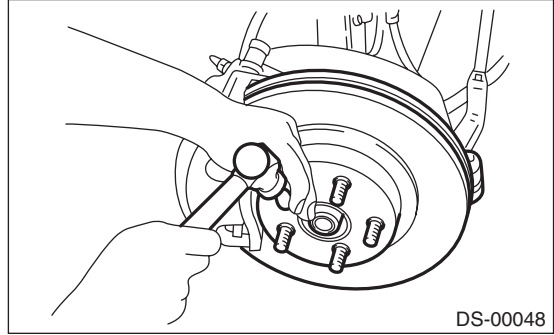

8) Install the rear wheels.

### Tightening torque:

**100 N·m (10.2 kgf·m, 73.8 ft·lb)**

## C: DISASSEMBLY

Using the ST and a hydraulic press, push out the hub bolts.

ST 28399AG000 HUB STAND

### CAUTION:

- Be careful not to hammer the hub bolts. This may deform the hub.
- Do not reuse the hub bolt.

### NOTE:

Since the hub unit bearing can not be disassembled, only hub bolts can be removed.

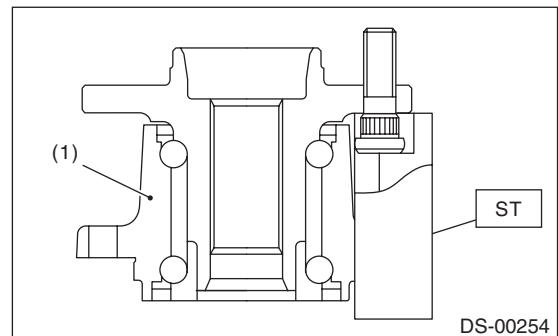

- (1) Rear hub unit bearing

### D: ASSEMBLY

- 1) Attach the hub to the ST securely.  
ST 28099PA080 HUB STAND

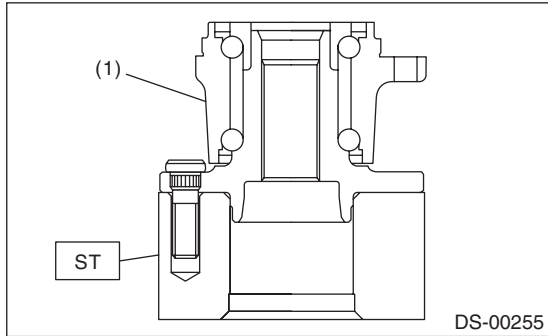

(1) Rear hub unit bearing

- 2) Using a press, press the new hub bolts until their seating surfaces contact the hub.

#### NOTE:

Use the 12 mm (0.47 in) dia. holes in the HUB STAND to prevent bolts from tilting.

### E: INSPECTION

- 1) Moving the rear tire up and down by hand, check there is no backlash in bearing, and check the wheel rotates smoothly.

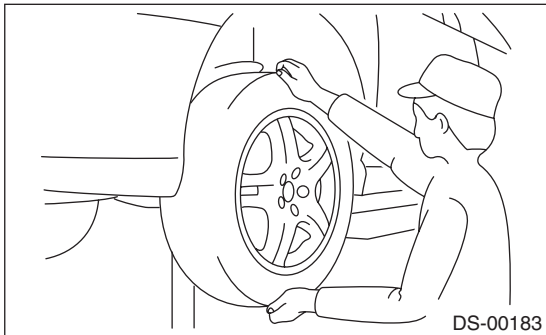

- 2) Inspect the lean of axis direction using a dial gauge. Replace the hub bearing if the play exceeds the limit value.

#### Service limit:

**Maximum: 0.05 mm (0.0020 in)**

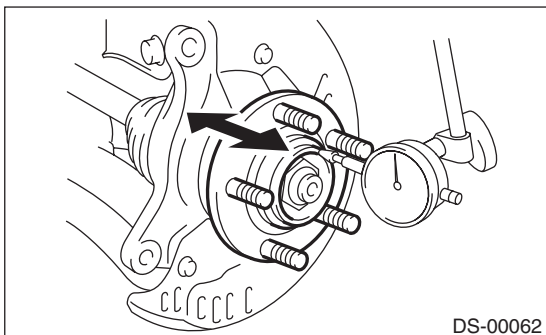



Brought to you by *Chris Studios*  
 NOT FOR SALE

## 7. Front Drive Shaft

### A: REMOVAL

- 1) Disconnect the ground cable from the battery.
- 2) Lift up the vehicle, and remove the front wheels.
- 3) Lift the crimped section of axle nut.

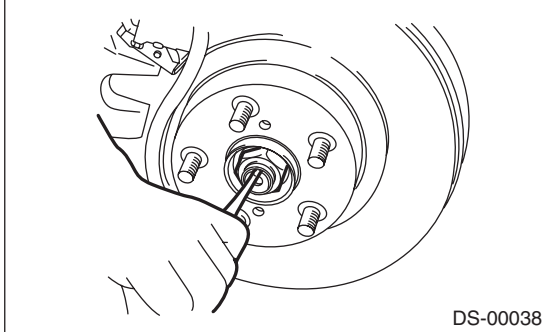

- 4) Remove the axle nut using a socket wrench while depressing the brake pedal.

**CAUTION:**

**Remove the wheel before loosening the axle nut. Failure to follow this rule may damage the wheel bearings.**

- 5) Drain the transmission gear oil.
- 6) Remove the stabilizer link from front arm.
- 7) Disconnect the front arm ball joint from the housing.

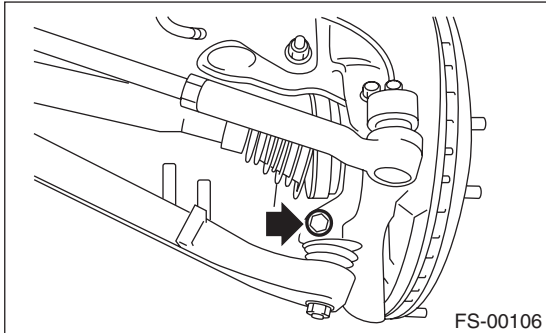

- 8) Remove the front drive shaft assembly. If it is hard to remove, use ST1 and ST2.

- |     |            |                         |
|-----|------------|-------------------------|
| ST1 | 926470000  | AXLE SHAFT PULLER       |
| ST2 | 28099PA110 | AXLE SHAFT PULLER PLATE |

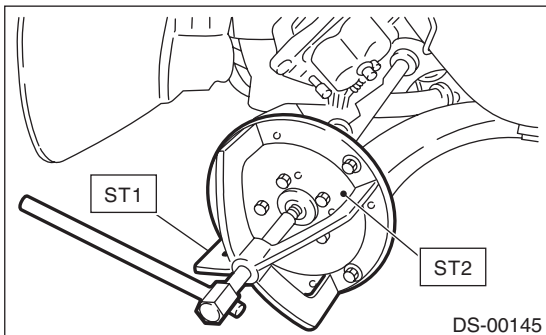

- 9) Using a bar, remove the front drive shaft from transmission.

**CAUTION:**

**Be careful not to allow the bar to damage holder area.**

### B: INSTALLATION

- 1) Replace the differential side retainer oil seal with a new part.

**NOTE:**

After pulling out the drive shaft, be sure to replace with a new oil seal.

**6MT model <Ref. to 6MT-29, REPLACEMENT, Differential Side Retainer Oil Seal.>**

- 2) Insert the AC into hub splines.
- 3) Draw the drive shaft into specified position.

**CAUTION:**

**Do not hammer drive shaft when installing it.**

- 4) Tighten the axle nut temporarily.
- 5) Using the ST, install the front drive shaft to transmission.

ST 28399SA010 OIL SEAL PROTECTOR

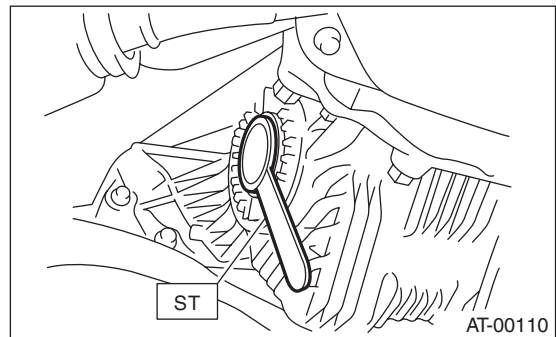

- 6) Connect the front arm ball joint to the housing.

**Tightening torque:**

**50 N·m (5.1 kgf-m, 36.9 ft-lb)**

- 7) Install the stabilizer link.

**CAUTION:**

**Be sure to use a new self-locking nut.**

**Tightening torque:**

**45 N·m (4.6 kgf-m, 33.2 ft-lb)**

- 8) While pressing the brake pedal, tighten the new axle nuts to the specified torque.

**Tightening torque:**

**220 N·m (22.4 kgf-m, 162 ft-lb)**

**CAUTION:**

- Do not install wheel and let it touch the ground before tightening the axle nut. Failure to follow this rule may damage the axle bearing.
- Do not overtighten the nuts as this may damage the axle bearing.

- 9) After tightening axle nut, lock it securely.

# Front Drive Shaft

Brought to you by Eris Studios  
NOT FOR RESALE

## DRIVE SHAFT SYSTEM

- 10) Fill the transmission gear oil.
- 11) Install the front wheels.

### Tightening torque:

**100 N·m (10.2 kgf·m, 73.8 ft·lb)**

- 12) Connect the ground cable to the battery.
- 13) Inspect the wheel alignment and adjust if necessary.

## C: DISASSEMBLY

- 1) Place alignment marks on the shaft and outer race.

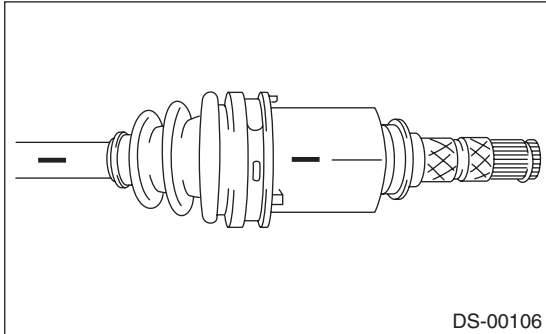

- 2) Remove the AAR boot band and boot.

### CAUTION:

**Be careful not to damage the boot.**

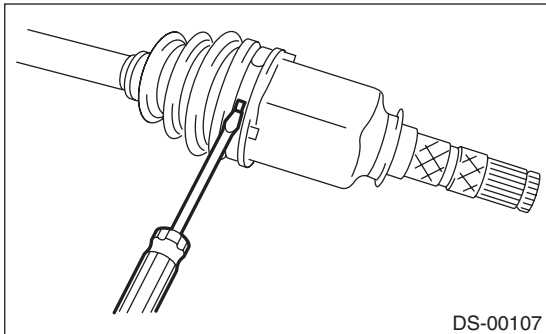

- 3) Place the drive shaft between wooden blocks and fix it on a vise.

### CAUTION:

**Do not fix the drive shaft on a vise directly.**

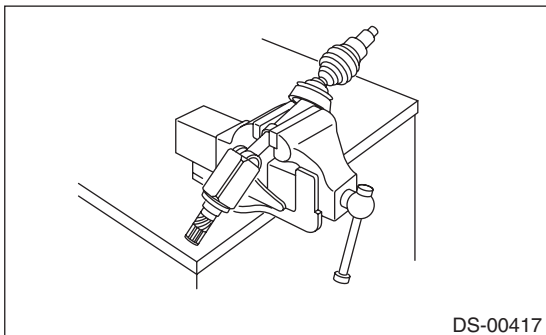

- 4) Tap the staking area of the outer race alternately with a plastic or wooden bar, and remove one roller at a time.

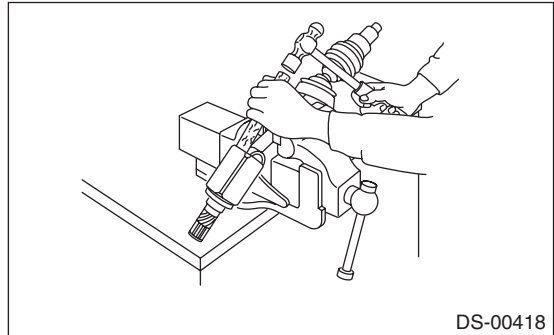

### CAUTION:

- Tap the staking area (A) of the outer race.
- Do not use a metal bar as the outer race may deform.
- Be careful not to damage the roller parts.

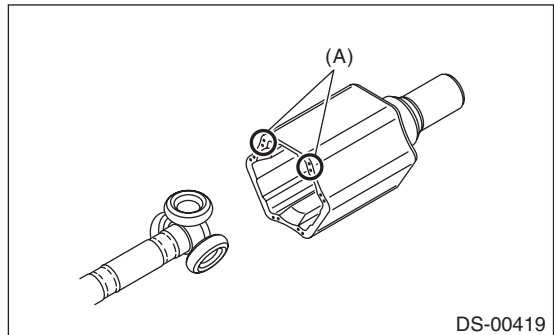

- 5) Remove the outer race from shaft assembly.

### CAUTION:

**Make sure to have your associate held the outer race when removing the third roller to prevent the outer race from falling.**

- 6) Wipe off grease.

### CAUTION:

**The grease is a special type of grease. Do not mix with other grease.**

Brought to you by *Meris Studios*  
 NOT FOR SALE

7) Place alignment marks on the roller kit and trunnion.

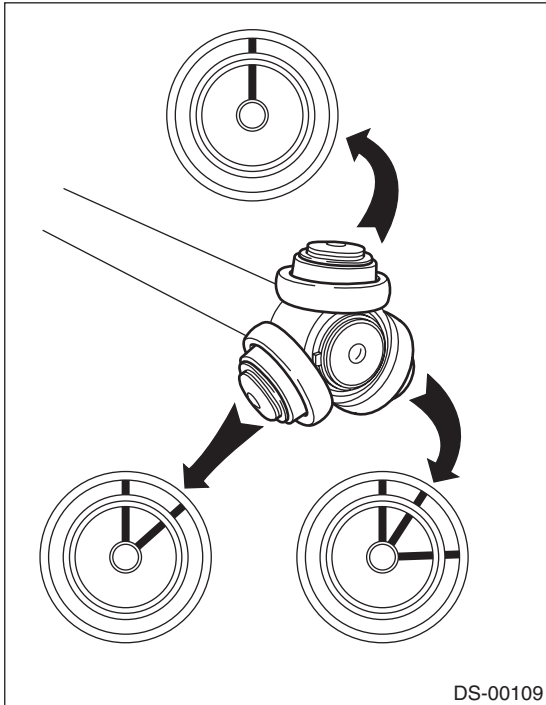

DS-00109

8) Remove the roller kit from trunnion.

**CAUTION:**

**Be careful with the roller kit position.**

9) Place alignment marks on the trunnion and shaft.

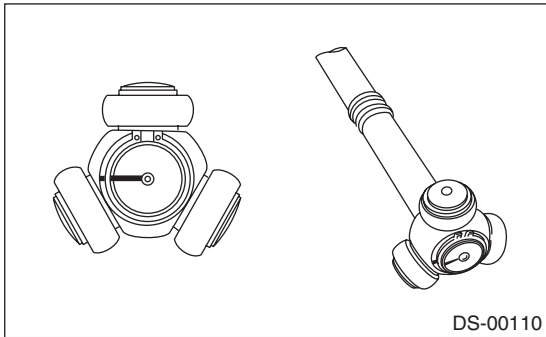

DS-00110

10) Remove the snap ring and trunnion.

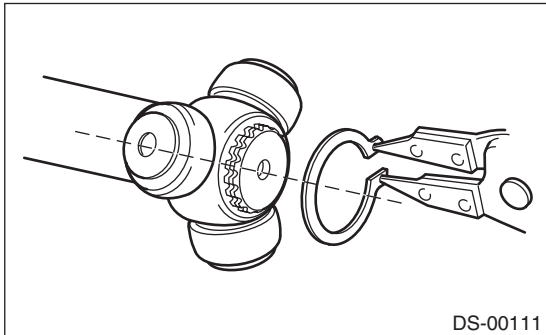

DS-00111

**CAUTION:**

**Be sure to wrap shaft splines with vinyl tape to protect the boot from scratches.**

11) Remove the AAR boot.

**NOTE:**

The AC is a non-disassembly part, so the drive shaft disassembly stops here.

**D: ASSEMBLY**

**NOTE:**

Use specified grease.

**AAR side:**

**ONE LOUVER C**

- 1) Pass the AAR boot through the shaft.
- 2) Align alignment marks and install the trunnion on the shaft. Install the snap ring into the shaft groove securely.

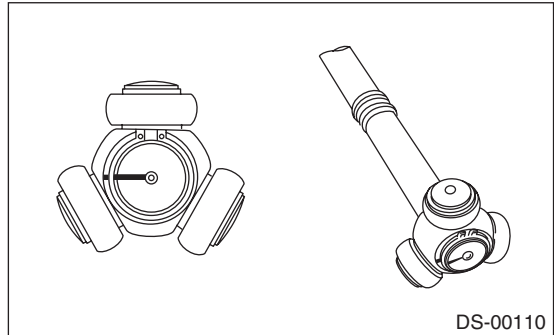

DS-00110

3) Fill 50 to 60 g (1.76 to 2.12 oz) of specified grease into the interior of AAR outer race.

4) Apply a thin coat of specified grease to the roller and trunnion.

5) Place the drive shaft between wooden blocks and fix it on a vise.

**CAUTION:**

**Do not fix the drive shaft on a vise directly.**

6) Align the alignment marks on the shaft and outer race.

7) Tap the area of the outer race where rollers are inserted alternately with a plastic or wooden bar to insert one roller at a time as shown in the figure.

**CAUTION:**

- Do not use a metal bar as the outer race may deform.
- Do not tap on the end of outer race (shaft part).
- Be careful not to deform the baffle plate.

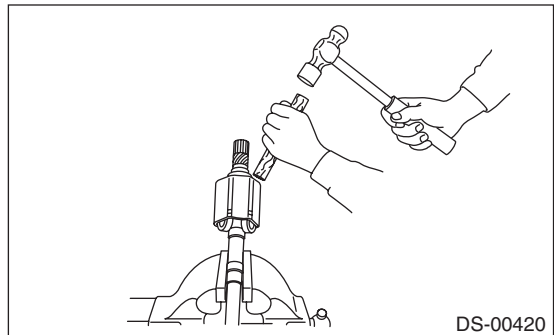

DS-00420

# Front Drive Shaft

Brought to you by Eris Studios  
NOT FOR RESALE

## DRIVE SHAFT SYSTEM

- 8) Apply an even coat of the specified grease 30 to 40 g (1.06 to 1.41 oz) to the entire inner surface of boot.
- 9) Install the AAR boot and grommet taking care not to twist it.

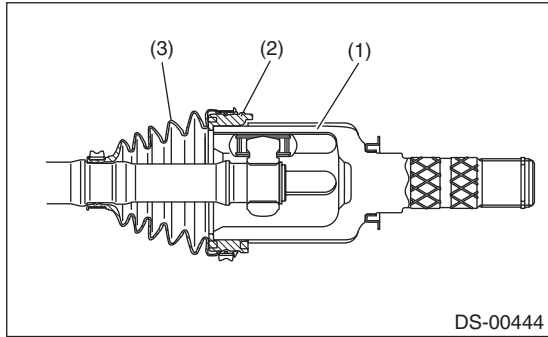

- (1) Outer race
- (2) Grommet
- (3) Boot

### CAUTION:

- Replace the boot and grommet as a set.
- Do not let grease get on groove of the outer race side.

- 10) Insert a flat tip screwdriver between outer race and grommet to make pressure inside of boot as high as barometric pressure.
- 11) Install the new large boot band and small boot band at the required positions.
- 12) Tighten the boot bands using ST, torque wrench and socket flex handle.

ST 28099AC000 BOOT BAND PLIER

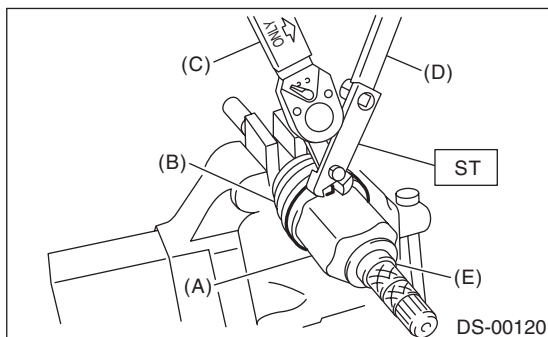

- (A) Large boot band
- (B) Boot
- (C) Torque wrench
- (D) Socket flex handle
- (E) AAR

### Clearance at the crimped section of the boot band:

#### Large boot band

1 mm (0.04 in) or less

#### Small boot band

1 mm (0.04 in) or less

- 13) Extend and retract the AAR repeatedly to provide an equal coating of grease.

### E: INSPECTION

Check the removed parts for damage, wear, corrosion etc. If faulty, repair or replace.

- AAR and AC

Check for seizure, corrosion, damage, wear and excessive play.

- Shaft

Check for excessive bending, twisting, damage and wear.

- Boot

Check for wear, warping, breakage and scratches.

- Grease

Check for discoloration and fluidity.

Brought to you by *Peris Studios*  
 NOT FOR SALE

## 8. Rear Drive Shaft

### A: REMOVAL

- 1) Disconnect the ground cable from the battery.
- 2) Lift up the vehicle, and then remove the rear wheels.
- 3) Lift the crimped section of axle nut.

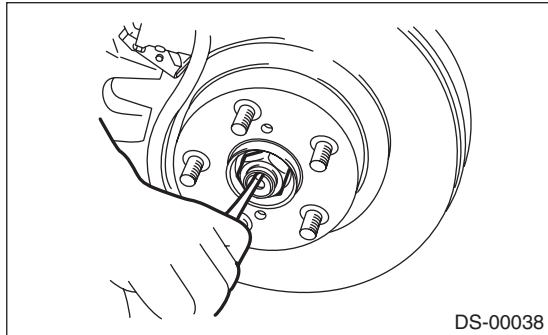

- 4) Remove the axle nut using a socket wrench while depressing the brake pedal.

**CAUTION:**

**Remove the wheel before loosening the axle nut. Failure to follow this rule may damage the wheel bearings.**

- 5) Drain the differential gear oil.
- 6) Remove the rear trailing link. <Ref. to RS-10, REMOVAL, Rear Trailing Link.>
- 7) Remove the rear lateral link. <Ref. to RS-15, REMOVAL, Rear Lateral Link.>

- 8) Remove the rear drive shaft from the rear differential by using the ST.

ST 28099PA100 DRIVE SHAFT REMOVER

**NOTE:**

Fit the ST to the bolts as shown in the figure to prevent damage of the side bearing retainer.

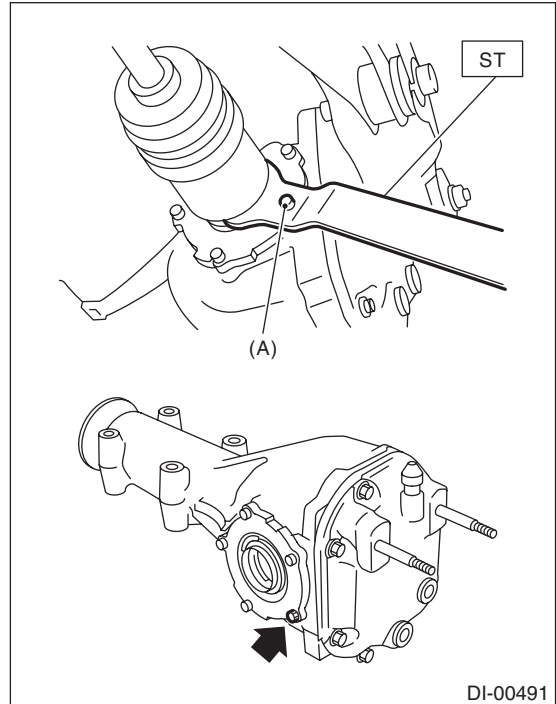

(A) Bolt

- 9) Remove the rear drive shaft from the rear axle. If it is hard to remove, use ST1 and ST2.

ST1 926470000 AXLE SHAFT PULLER  
 ST2 28099PA110 AXLE SHAFT PULLER PLATE

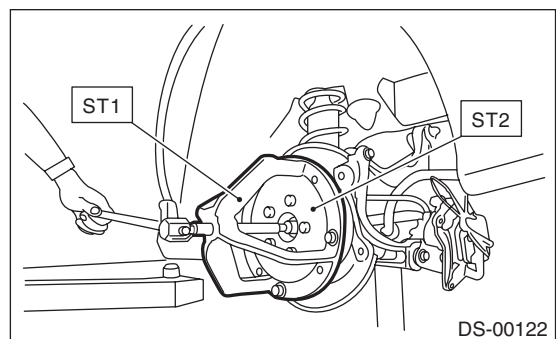

## DRIVE SHAFT SYSTEM

### B: INSTALLATION

1) Replace the rear differential side oil seal. <Ref. to DI-37, REPLACEMENT, Rear Differential Side Oil Seal.>

**NOTE:**

After pulling out the drive shaft, be sure to replace with a new oil seal.

2) Insert the EBJ into rear hub splines.

**CAUTION:**

- Be careful not to damage the magnetic encoder.
- Do not get closer the tool which charged magnetism to magnetic encoder.

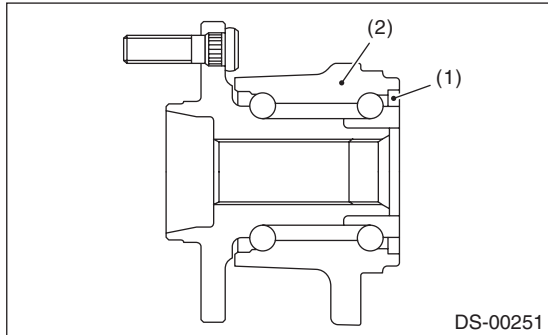

- (1) Magnetic encoder
- (2) Rear hub unit bearing

3) Draw the rear drive shaft into specified position.

**CAUTION:**

**Do not hammer drive shaft when installing it.**

4) Tighten the axle nut temporarily.

5) Using the ST, install the rear drive shaft to the rear differential.

ST 28099PA090 OIL SEAL PROTECTOR

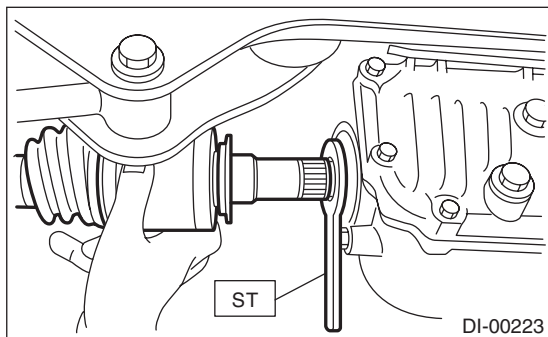

6) Attach the links to the rear housing and tighten them to the specified torque.

**Tightening torque:**

**Stabilizer link**

45 N·m (4.6 kgf-m, 33.2 ft-lb)

**Shock absorber**

120 N·m (12.2 kgf-m, 89 ft-lb)

**Rear lateral link**

120 N·m (12.2 kgf-m, 89 ft-lb)

**Trailing link**

90 N·m (9.2 kgf-m, 66.4 ft-lb)

7) While pressing the brake pedal, tighten the new axle nuts to the specified torque.

**Tightening torque:**

190 N·m (19.4 kgf-m, 140 ft-lb)

**CAUTION:**

- Do not install wheel and let it touch the ground before tightening the axle nut. Failure to follow this rule may damage the axle bearing.
- Do not overtighten the nuts as this may damage the axle bearing.

8) Lock the axle nut securely.

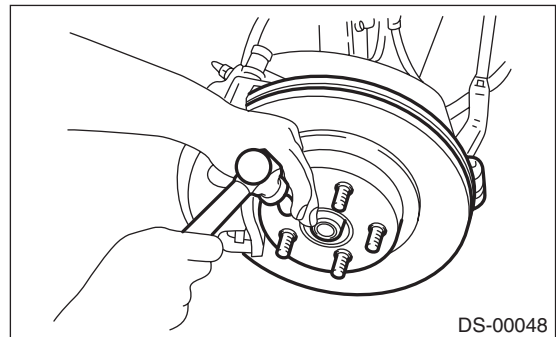

9) Fill the differential gear oil.

10) Install the rear wheels.

**Tightening torque:**

100 N·m (10.2 kgf-m, 73.8 ft-lb)

11) Connect the ground cable to the battery.

12) Inspect the wheel alignment and adjust if necessary.

Brought to you by *Meris Studios*  
 NOT FOR SALE

### C: DISASSEMBLY

1) Using a flat tip screwdriver or plier, loosen the boot band on the large end of EDJ boot.

**CAUTION:**

**Be careful not to damage the boot.**

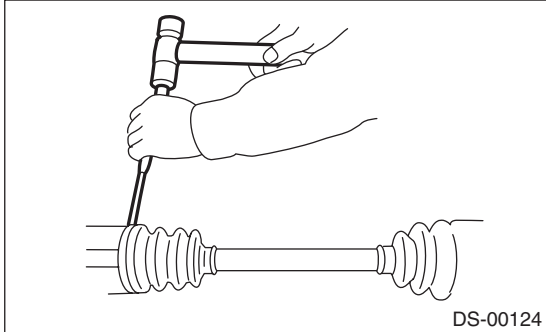

- 2) Remove the boot band on the small end of EDJ boot in the same manner.
- 3) Remove the larger end of EDJ boot from EDJ outer race.
- 4) Remove the round snap ring at the neck of EDJ outer race with a flat tip screwdriver.

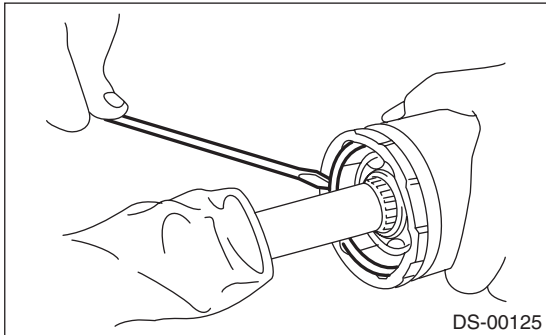

- 5) Remove the EDJ outer race from shaft assembly.
- 6) Wipe off the grease and take out the ball bearings.

**CAUTION:**

**The grease is a special grease (grease for constant velocity joints). Do not mix with other greases.**

**NOTE:**

Disassemble exercising care not to lose balls (6 pcs).

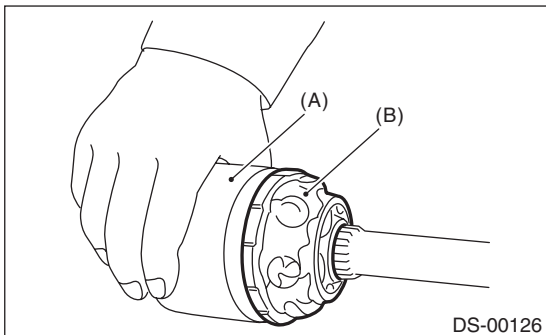

- (A) Outer race
- (B) Grease

- 7) To remove the cage from inner race, turn the cage by a half pitch to the track groove of inner race and shift the cage.
- 8) Using pliers, remove the snap ring fixing the inner race to the shaft.
- 9) Take out the EDJ inner race.
- 10) Take off the EDJ cage from shaft and remove the EDJ boot.

**CAUTION:**

**Wrap shaft splines with vinyl tape to protect the boot from scratches.**

11) Remove the EBJ boot using the same procedures as for the EDJ boot.

**NOTE:**

The EBJ is a non-disassembly part, so the drive shaft disassembly stops here.

# Rear Drive Shaft

## DRIVE SHAFT SYSTEM

### D: ASSEMBLY

#### CAUTION:

Wrap shaft splines with vinyl tape to protect the boot from scratches.

#### NOTE:

Use specified grease.

#### EBJ side

**NKG106**

#### EDJ side:

**NKG205**

- 1) Install the EBJ boot to the specified position, and fill it with 50 to 60 g (1.76 to 2.12 oz) of specified grease.
- 2) Place the EDJ boot at the center of shaft.
- 3) Insert the EDJ cage onto shaft.

#### NOTE:

Insert the cage with the cutout portion facing the shaft end, since the cage has an orientation.

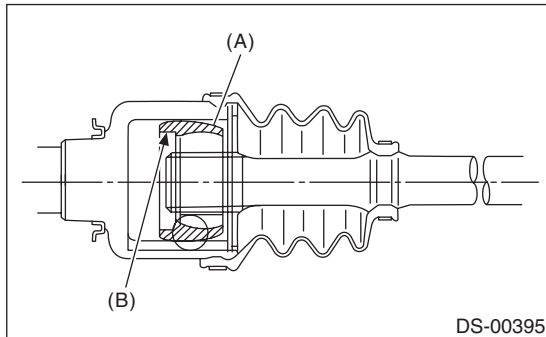

- (A) Cage
- (B) Cutout portion

- 4) Install the EDJ inner race on shaft and fix the snap ring in place with pliers.

#### NOTE:

Confirm that the snap ring is completely fitted in the shaft groove.

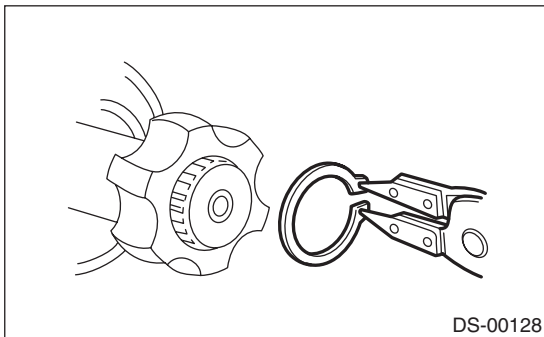

DS-00128

- 5) Install the cage to inner race fixed upon shaft.

#### NOTE:

Fit the cage with the protruding section aligned with the track on the inner race, and turn by a half pitch.

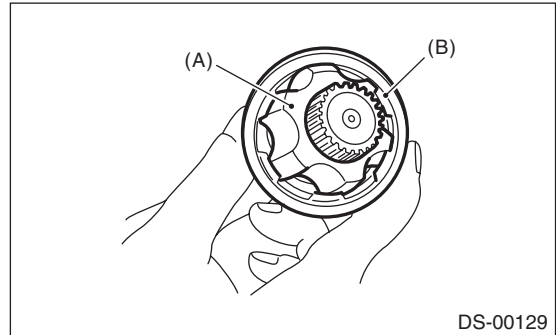

- (A) Inner race
- (B) Cage

- 6) Fill 80 to 90 g (2.82 to 3.17 oz) of specified grease into the inner side of the EDJ outer race.
- 7) Apply a thin coat of specified grease to the cage pocket and six ball bearings.
- 8) Insert the six ball bearings into the cage pocket.
- 9) Align the outer race track and ball positions, and place the shaft, inner race, cage and ball bearings in the original positions, and then fix outer race in place.

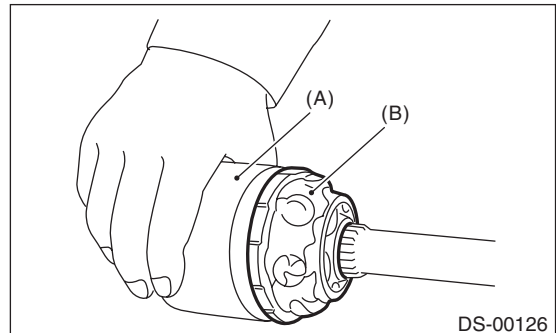

- (A) Outer race
- (B) Grease



Brought to you by *Peris Studios*  
 NOT FOR SALE

10) Install the snap ring in the groove on the EDJ outer race.

**NOTE:**

- Assure that the balls, cage and inner race are completely fitted in the outer race of EDJ.
- Use care not to place the matched position of snap ring in the ball groove of outer race.
- Pull the shaft lightly and assure that the circlip is completely fitted in the groove.

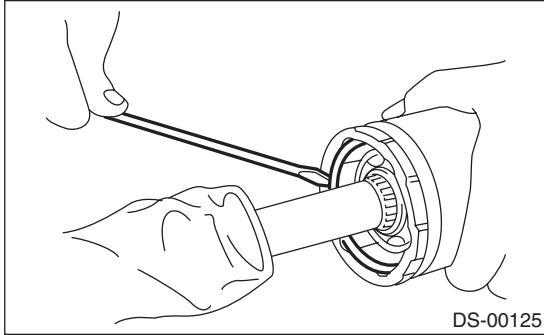

11) Apply an even coat of the specified grease [20 to 30 g (0.71 to 1.06 oz)] to the entire inner surface of boot. Also apply grease to the shaft.

12) Install the EDJ boot taking care not to twist it.

**NOTE:**

- The inside of the larger end of EDJ boot and the boot groove shall be cleaned so as to be free from grease and other substances.
- When installing the EDJ boot, position the outer race of EDJ at center of the stroke.

13) Put a new band through the clip and wind twice in the band groove of the boot.

14) Pinch the end of band with pliers. Hold the clip and tighten securely.

**NOTE:**

When tightening boot, use care so that the air within the boot is appropriate.

15) Tighten the band using the ST.

ST 925091000 BAND TIGHTENING TOOL

**NOTE:**

Tighten the band until it cannot be moved by hand.

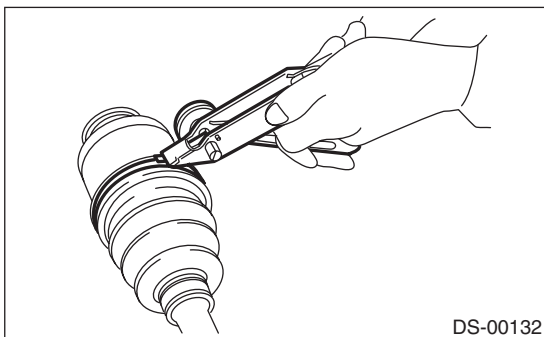

16) Tap the clip with the punch provided at the end of the ST.

ST 925091000 BAND TIGHTENING TOOL

**NOTE:**

Tap to an extent that the boot underneath is not damaged.

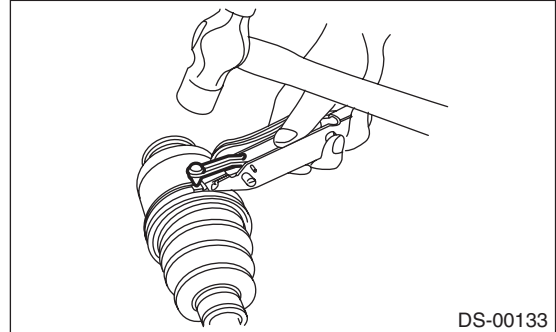

17) Cut off the band with an allowance of about 10 mm (0.39 in) left from the clip and bend this allowance over the clip.

**NOTE:**

Be careful so that the end of the band is in close contact with clip.

18) Install the EBJ boot using the same procedures as for the EDJ boot.

19) Extend and retract the EDJ repeatedly to provide an equal coating of grease.

### E: INSPECTION

Check the removed parts for damage, wear, corrosion etc. Repair or replace if defective.

- EDJ (high-efficiency compact double offset joint)  
Check for seizure, corrosion, damage, wear and excessive play.

- EBJ (high-efficiency compact ball fixed joint)  
Check for seizure, corrosion, damage, wear and excessive play.

- Shaft  
Check for excessive bending, twisting, damage and wear.

- Boot  
Check for wear, warping, breakage and scratches.

- Grease  
Check for discoloration and fluidity.

# General Diagnostic Table

## DRIVE SHAFT SYSTEM

Brought to you by Eris Studios  
NOT FOR RESALE

### 9. General Diagnostic Table

#### A: INSPECTION

**NOTE:**

Vibration while cruising may be caused by an unbalanced tire, improper tire inflation pressure, improper wheel alignment, etc.

Symptoms	Possible cause	Corrective action
<b>Noise or vibration from propeller shaft</b>	Center bearing	Check the center bearing. <Ref. to DS-12, CENTER BEARING FREE PLAY, INSPECTION, Propeller Shaft.>
	Runout of propeller shaft	Check for deflection of the propeller shaft. <Ref. to DS-12, RUNOUT OF PROPELLER SHAFT, INSPECTION, Propeller Shaft.>
	Loose or gap at connections	Check the joints and connectors. <Ref. to DS-11, JOINTS AND CONNECTORS, INSPECTION, Propeller Shaft.>
Check the spline and bearing. <Ref. to DS-11, SPLINES AND BEARING, INSPECTION, Propeller Shaft.>		
<b>Abnormal wheel vibration</b>	Wheel is out of balance.	Check the wheel balance. <Ref. to WT-7, ADJUSTMENT, Wheel Balancing.>
	Front wheel alignment	Check the front wheel alignment. <Ref. to FS-6, INSPECTION, Wheel Alignment.>
	Rear wheel alignment	Check the rear wheel alignment. <Ref. to RS-8, INSPECTION, Wheel Alignment.>
	Front strut	Check the front strut. <Ref. to FS-23, INSPECTION, Front Strut.>
	Rear shock absorber	Check the rear shock absorber. <Ref. to RS-13, INSPECTION, Rear Shock Absorber.>
	Front drive shaft	Check the front drive shaft. <Ref. to DS-28, INSPECTION, Front Drive Shaft.>
	Rear drive shaft	Check the rear drive shaft. <Ref. to DS-33, INSPECTION, Rear Drive Shaft.>
	Front hub unit bearing	Check the front hub unit bearing. <Ref. to DS-18, INSPECTION, Front Hub Unit Bearing.>
	Rear hub unit bearing	Check the rear hub unit bearing. <Ref. to DS-24, INSPECTION, Rear Hub Unit Bearing.>
<b>Noise from the underbody</b>	Wheel is out of balance.	Check the wheel balance. <Ref. to WT-7, ADJUSTMENT, Wheel Balancing.>
	Front wheel alignment	Check the front wheel alignment. <Ref. to FS-6, INSPECTION, Wheel Alignment.>
	Rear wheel alignment	Check the rear wheel alignment. <Ref. to RS-8, INSPECTION, Wheel Alignment.>
	Front strut	Check the front strut. <Ref. to FS-23, INSPECTION, Front Strut.>
	Rear shock absorber	Check the rear shock absorber. <Ref. to RS-13, INSPECTION, Rear Shock Absorber.>