

Brought to you by Eris Studios
NOT FOR RESALE

POWER ASSISTED SYSTEM (POWER STEERING)

General Description

POWER ASSISTED SYSTEM (POWER STEERING)

Brought to you by Eris Studios
NOT FOR RESALE

1. General Description

A: SPECIFICATION

Model		STI	
Whole system	Minimum turning radius	m (ft)	5.5 (18)
	Steering angle	Inner wheel	36.6°±1.5°
		Outer wheel	32.2°±1.5°
	Steering wheel diameter	mm (in)	375 (14.76)
Total gear ratio (while turning, from lock to lock. Gearbox)			2.8
Gearbox	Type	Rack and Pinion, Integral	
	Backlash	0 (Automatic adjusting)	
	Valve (Power steering system)	Rotary valve	
Pump (Power steering system)	Type	Vane pump	
	Oil tank	Installed on body	
	Specific output	cm ³ (cu in)/rev.	8.5 (0.519)
	Relief pressure	kPa (kgf/cm ² , psi)	8,300 — 9,000 (85 — 92, 1,203 — 1,305)
	Hydraulic fluid control	Engine speed sensitive	
	Hydraulic fluid	ℓ (US qt, Imp qt)	1,000 rpm: 6.3 (6.7, 5.5) 3,000 rpm: 5.9 (6.2, 5.2)
	RPM range	rpm	680 — 9,600
Direction of rotation		Clockwise	
Hydraulic oil (Power steering system)	Capacity ℓ (US qt, Imp qt)	Oil tank	0.2 (0.2, 0.2)
		Whole system	0.7 (0.7, 0.6)

Steering wheel	Free play	mm (in)	17 (0.67)	
Steering shaft	Clearance between the steering wheel and column cover	mm (in)	2 — 4 (0.08 — 0.16)	
Steering gearbox (Power steering system)	Rack shaft play in the radial direction	Right-turn steering	mm (in)	0.12 (0.005) or less
		In radial direction	mm (in)	0.26 (0.01) or less
	Input shaft play	In axial direction	mm (in)	Without play
		Rotation resistance	N (kgf, lbf)	Maximum allowable value: 11.3 (1.15, 2.54) or less Difference between right and left sliding resistance: 24%
Oil pump (Power steering system)	Pulley shaft	Radial play	mm (in)	0.4 (0.016) or less
		Axial play	mm (in)	0.9 (0.035) or less
	Pulley	Ditch deflection	mm (in)	1.0 (0.039) or less
		Rotation resistance	N (kgf, lbf)	9.22(0.94, 2.07) or less
Regular pressure (Unloaded)		kPa (kgf/cm ² , psi)	981(10, 142) or less	
Steering wheel effort (Power steering system)	At standstill with engine idling on paved road	N (kgf, lbf)	29.4(3.0, 6.6) or less	
	At standstill with engine stalled on paved road	N (kgf, lbf)	294.2(30, 66.2) or less	

Recommended power steering fluid
SUBARU ATF or DEXRON III

General Description

POWER ASSISTED SYSTEM (POWER STEERING)

Brought to you by Eris Studios
NOT FOR SALE

B: COMPONENT

1. STEERING WHEEL AND COLUMN

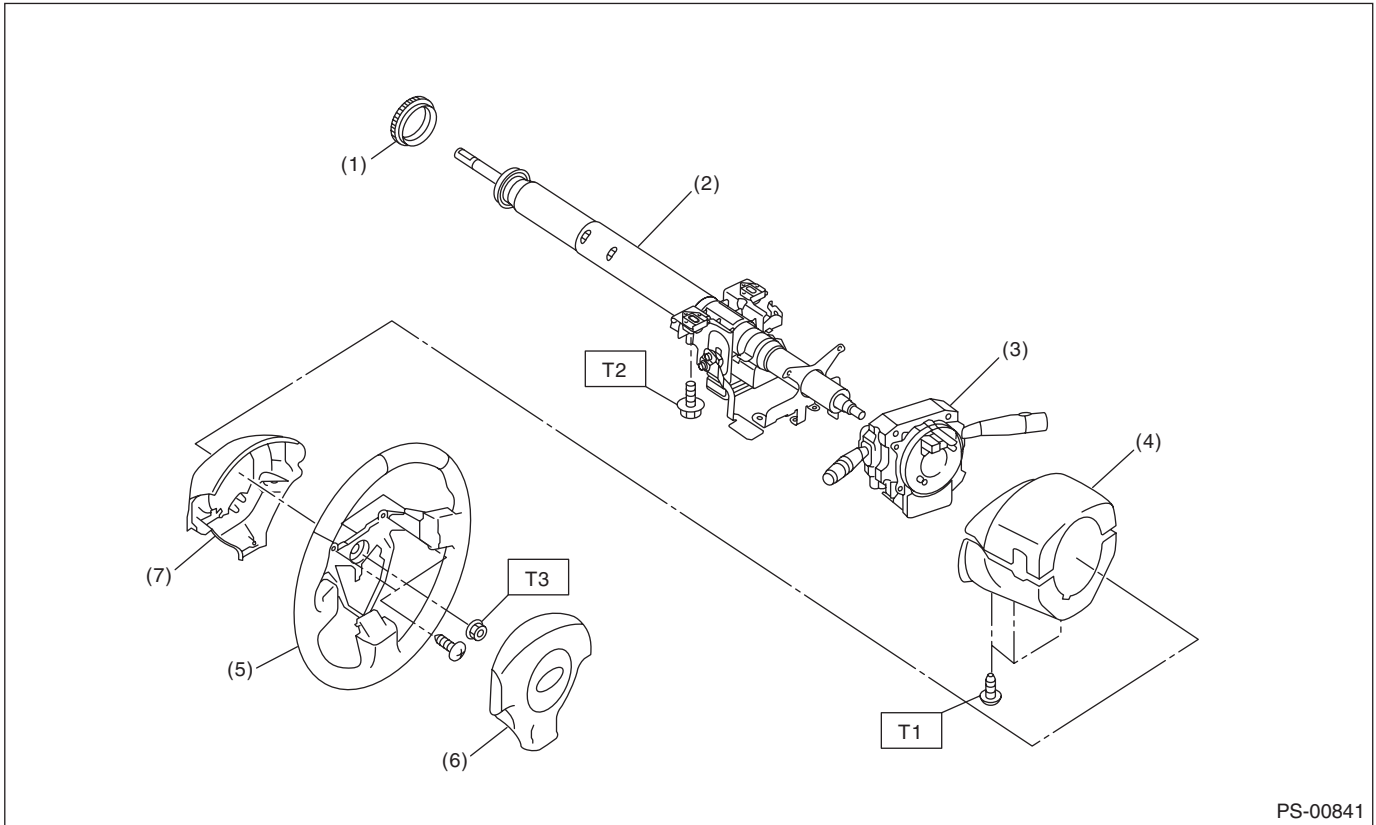

- | | |
|-----------------------------|--------------------------------|
| (1) Bushing | (5) Steering wheel |
| (2) Steering shaft | (6) Airbag module |
| (3) Steering roll connector | (7) Steering wheel lower cover |
| (4) Column cover | |

Tightening torque: N·m (kgf·m, ft·lb)

T1: 1.2 (0.12, 0.9)

T2: 25 (2.5, 18.4)

T3: 39 (4.0, 28.8)

General Description

POWER ASSISTED SYSTEM (POWER STEERING)

Brought to you by Eris Studios
NOT FOR RESALE

2. POWER ASSISTED SYSTEM

- Hose and tank

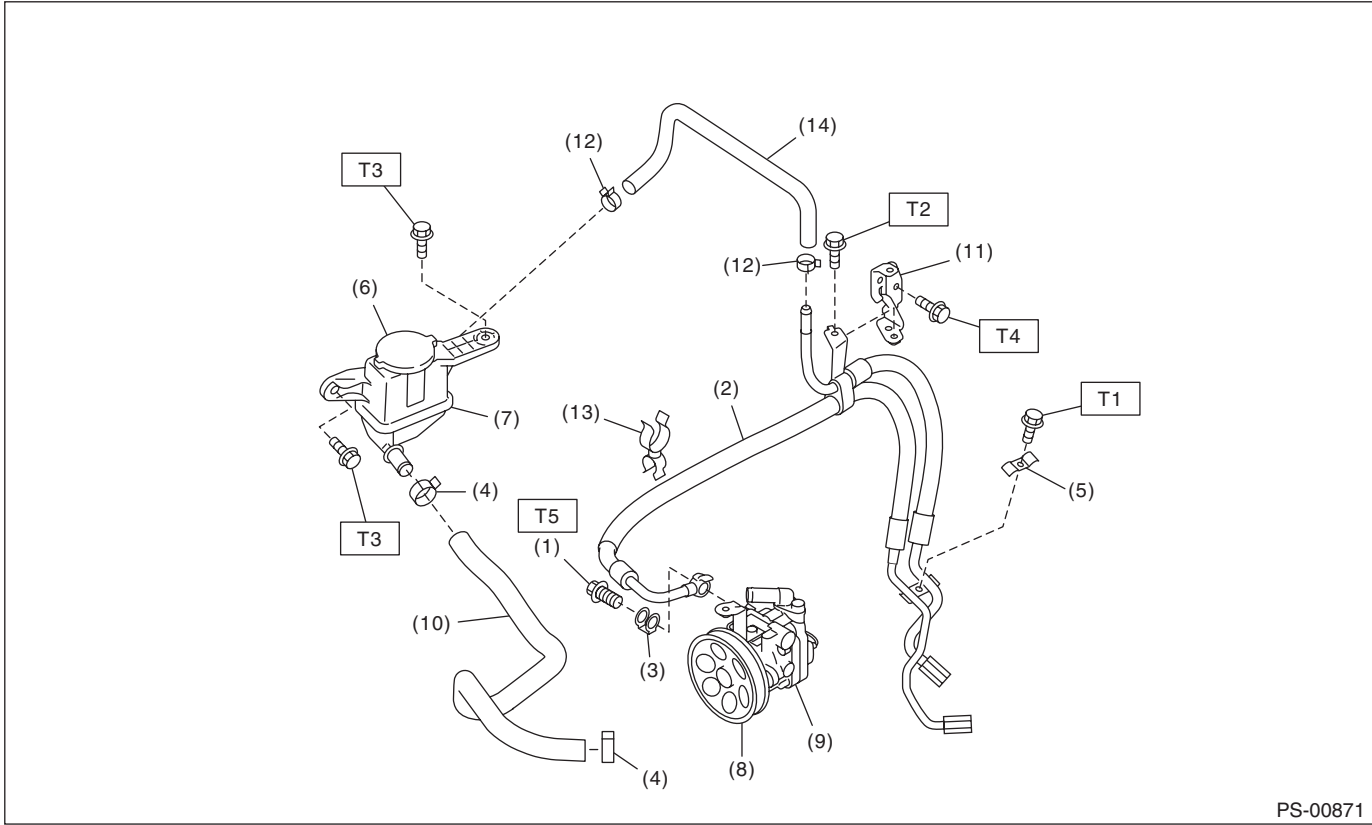

PS-00871

- | | |
|---------------------|-------------------|
| (1) Eye bolt | (8) Pulley |
| (2) Hose | (9) Oil pump |
| (3) Eye bolt gasket | (10) Suction hose |
| (4) Clip | (11) Hose bracket |
| (5) Clamp E | (12) Clip |
| (6) Cap | (13) Clip |
| (7) Reservoir tank | (14) Return hose |

Tightening torque: N·m (kgf·m, ft·lb)

T1: 7.5 (0.76, 5.53)

T2: 10 (1.02, 7.4)

T3: 13 (1.32, 9.6)

T4: 18 (1.84, 13.3)

T5: 40 (4.1, 29.5)

General Description

POWER ASSISTED SYSTEM (POWER STEERING)

Brought to you by Eris Studios
NOT FOR SALE

• Gearbox

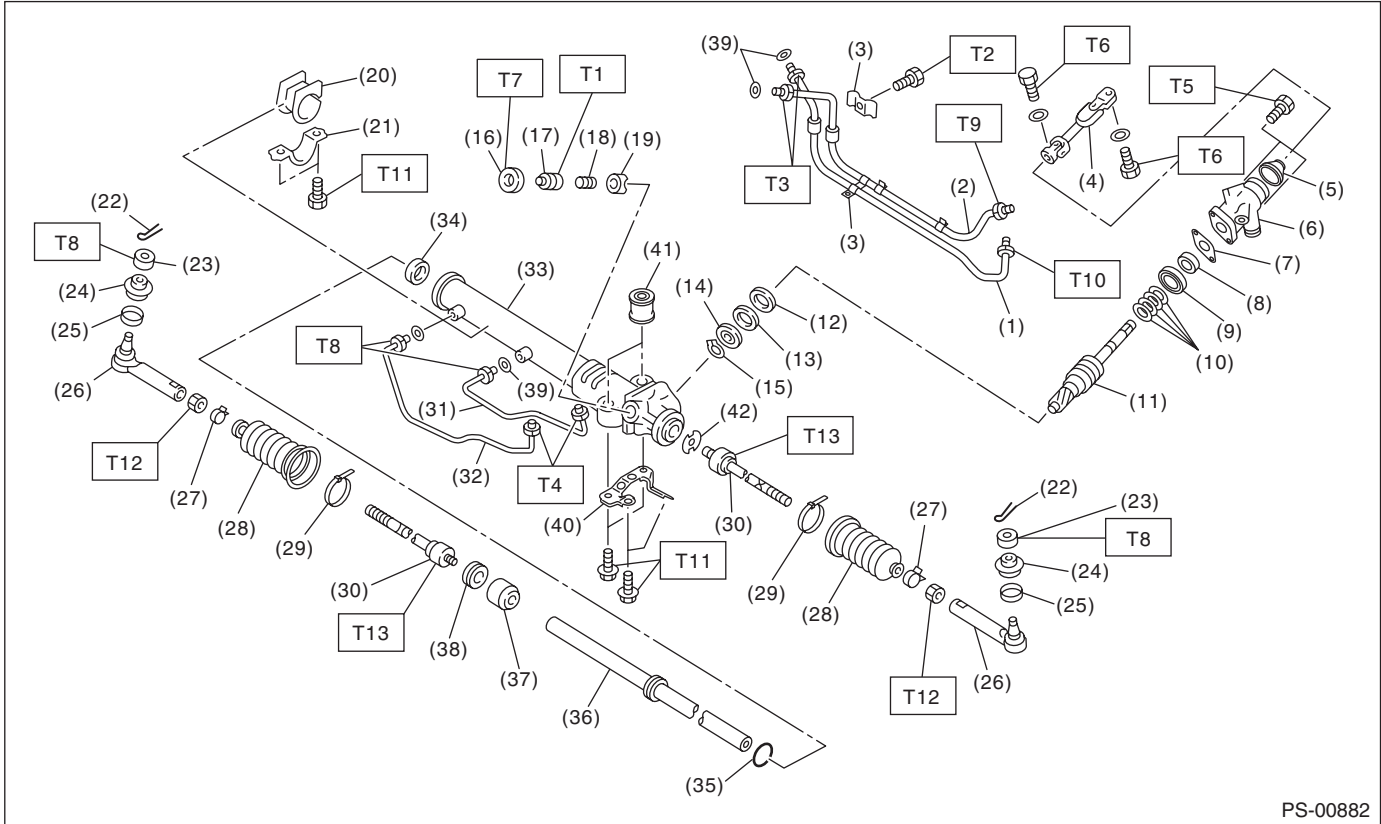

PS-00882

- | | | |
|--------------------------|--------------------|------------------|
| (1) Pipe C | (20) Adapter | (39) O-ring |
| (2) Pipe D | (21) Clamp | (40) Bracket |
| (3) Clamp plate | (22) Cotter pin | (41) Bushing |
| (4) Universal joint | (23) Castle nut | (42) Lock washer |
| (5) Dust seal | (24) Dust cover | |
| (6) Valve housing | (25) Clip | |
| (7) Gasket | (26) Tie-rod end | |
| (8) Oil seal | (27) Clip | |
| (9) Bushing | (28) Boot | |
| (10) Seal ring | (29) Band | |
| (11) Pinion & valve ASSY | (30) Tie-rod | |
| (12) Oil seal | (31) Pipe B | |
| (13) Back-up washer | (32) Pipe A | |
| (14) Ball bearing | (33) Steering body | |
| (15) Snap ring | (34) Oil seal | |
| (16) Lock nut | (35) Piston ring | |
| (17) Adjusting screw | (36) Rack | |
| (18) Spring | (37) Rack bushing | |
| (19) Sleeve | (38) Holder | |

Tightening torque: N·m (kgf·m, ft·lb)

- | | |
|-------------|------------------------|
| T1: | 3.9 (0.4, 2.9) |
| T2: | 10 (1.02, 7.4) |
| T3: | 15 (1.5, 10.8) |
| T4: | 17 (1.7, 12.5) |
| T5: | 20 (2.0, 14.8) |
| T6: | 24 (2.4, 17.4) |
| T7: | 25 (2.5, 18.1) |
| T8: | 27 (2.75, 19.9) |
| T9: | 37 (3.8, 27.3) |
| T10: | 29 (3.0, 21.4) |
| T11: | 60 (6.1, 44.1) |
| T12: | 85 (8.7, 62.7) |
| T13: | 90 (9.1, 65.8) |

General Description

POWER ASSISTED SYSTEM (POWER STEERING)

Brought to you by Eris Studios
NOT FOR RESALE

3. OIL PUMP

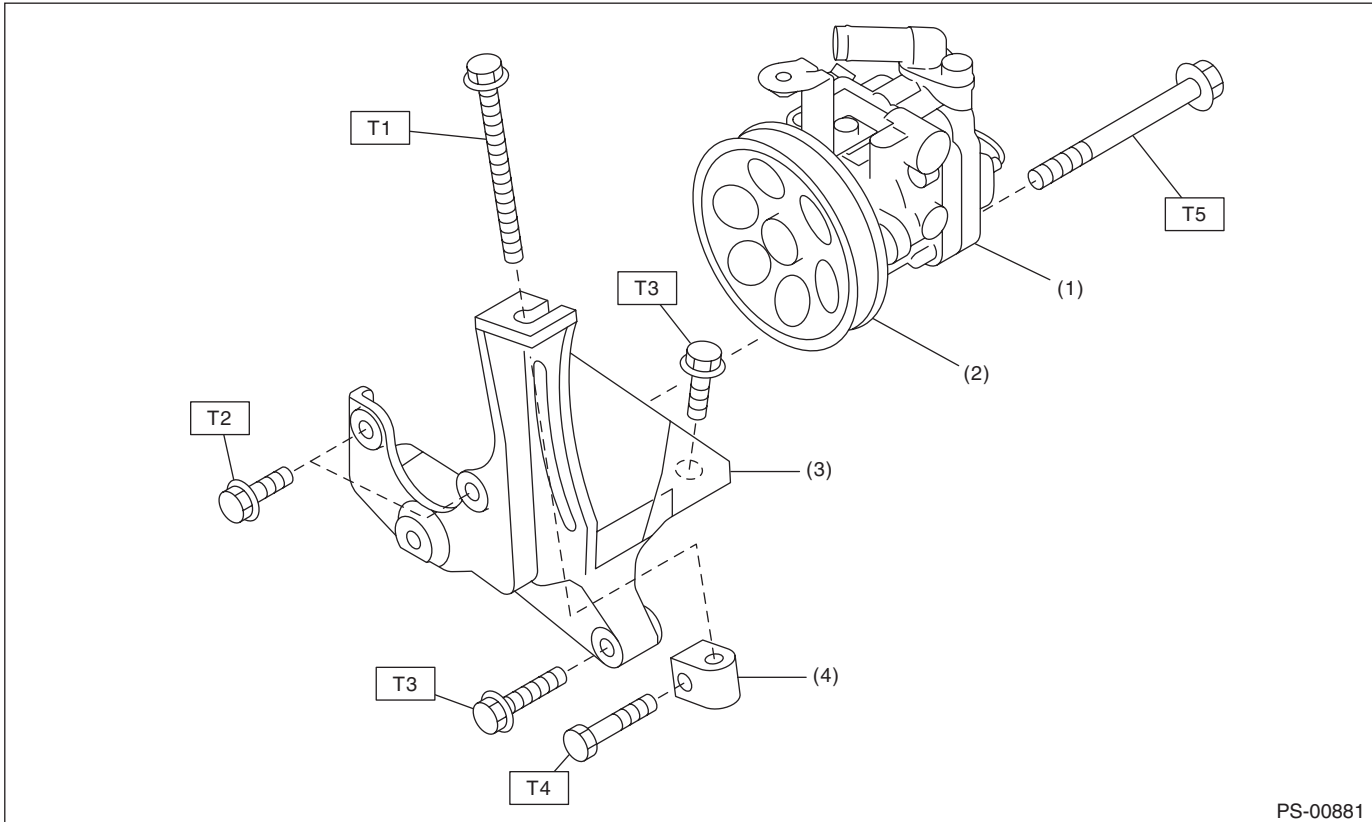

PS-00881

- (1) Oil pump
- (2) Pulley
- (3) Bracket
- (4) Belt tension nut

Tightening torque: N-m (kgf-m, ft-lb)

- T1: 8 (0.8, 5.8)**
- T2: 16 (1.6, 11.8)**
- T3: 22 (2.2, 15.9)**
- T4: 25 (2.5, 18.4)**
- T5: 48 (4.9, 35.4)**

C: CAUTION

- Wear appropriate work clothing, including a cap, protective goggles and protective shoes when performing any work.
- Before removal, installation or disassembly, be sure to clarify the failure. Avoid unnecessary removal, installation, disassembly and replacement.
- Vehicle components are extremely hot after driving. Be wary of receiving burns from heated parts.
- Use SUBARU genuine power steering fluid, grease etc. or the equivalent. Do not mix fluid, grease etc. of different grades or manufacturers.
- Be sure to tighten fasteners including bolts and nuts to the specified torque.
- Place shop jacks or rigid racks at the specified points.
- Before securing a part on a vise, place cushioning material such as wooden blocks, aluminum plate or cloth between the part and the vise.

General Description

POWER ASSISTED SYSTEM (POWER STEERING)

Brought to you by Eris Studios
NOT FOR SALE

D: PREPARATION TOOL

1. SPECIAL TOOL

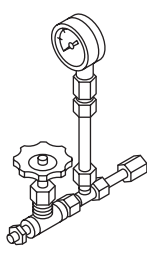
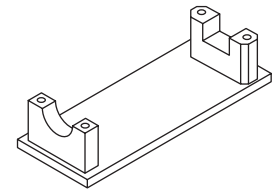
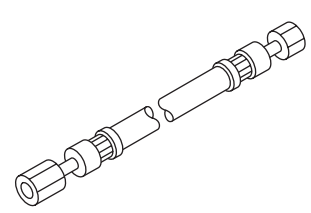
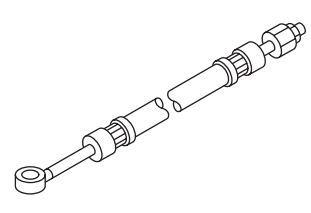
ILLUSTRATION	TOOL NUMBER	DESCRIPTION	REMARKS
 <p>ST-925711000</p>	925711000	PRESSURE GAUGE	Used for measuring oil pressure.
 <p>ST-926200000</p>	926200000	STAND	<ul style="list-style-type: none"> Used when inspecting characteristic of gear-box assembly and disassembling it. Used together with BOSS D (34199AG000).
 <p>ST34099AC010</p>	34099AC010	ADAPTER HOSE A	Used together with PRESSURE GAUGE (925711000).
 <p>ST34099AC020</p>	34099AC020	ADAPTER HOSE B	Used together with PRESSURE GAUGE (925711000).

General Description

POWER ASSISTED SYSTEM (POWER STEERING)

Brought to you by Eris Studios
NOT FOR RESALE

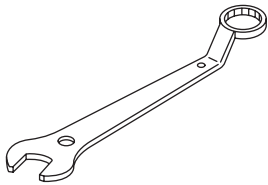
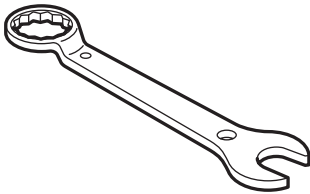
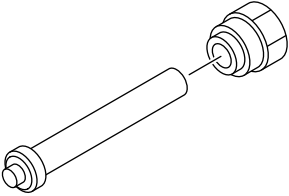
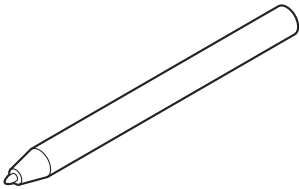
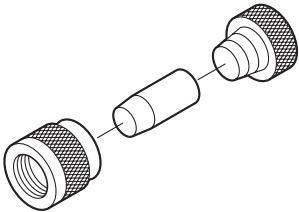
ILLUSTRATION	TOOL NUMBER	DESCRIPTION	REMARKS
 <p style="text-align: center;">ST-926230000</p>	926230000	SPANNER	For the lock nut when adjusting backlash of gearbox.
 <p style="text-align: center;">ST34099PA100</p>	34099PA100	SPANNER	Used when measuring the rotating resistance of gearbox assembly.
 <p style="text-align: center;">ST-926420000</p>	926420000	PLUG	When fluid leaks from pinion side of gearbox assembly, remove pipe B from valve housing, attach this tool and check fluid leaking points.
 <p style="text-align: center;">ST34099FA060</p>	34099FA060	PUNCH HOLDER	Used for crimping.
 <p style="text-align: center;">ST34199FE040</p>	34199FE040	INSTALLER A, B, C	Used for installing the oil seal to the rack assembly.

General Description

POWER ASSISTED SYSTEM (POWER STEERING)

Brought to you by *Tris Studios*
 NOT FOR SALE

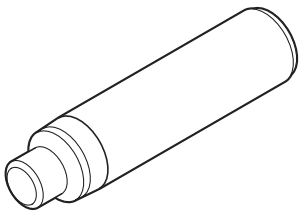
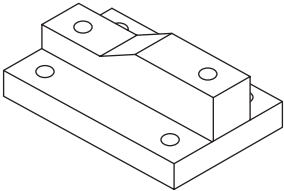
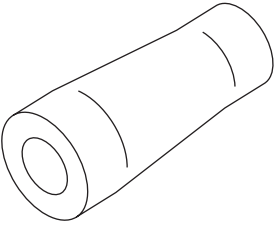
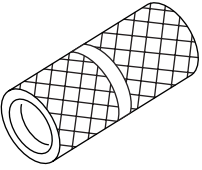
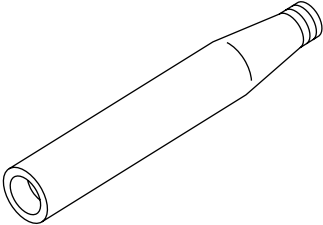
ILLUSTRATION	TOOL NUMBER	DESCRIPTION	REMARKS
 <p data-bbox="326 520 467 541">ST34199FE000</p>	34199FE000	INSTALLER & REMOVER	Used for removing and installing the rack oil seal (outer & inner).
 <p data-bbox="326 869 467 890">ST34199AG000</p>	34199AG000	BOSS D	<ul style="list-style-type: none"> • Used when inspecting characteristic of gear-box assembly and disassembling it. • Used together with STAND (926200000).
 <p data-bbox="326 1222 467 1243">ST34199AG040</p>	34199AG040	GUIDE	Used for installing seal ring of rack.
 <p data-bbox="326 1575 467 1596">ST34199AG070</p>	34199AG070	FORMER	Used for forming seal ring of pinion.
 <p data-bbox="326 1923 467 1944">ST34199AG020</p>	34199AG020	GUIDE	Used for installing seal ring of pinion.

General Description

POWER ASSISTED SYSTEM (POWER STEERING)

Brought to you by Eris Studios
NOT FOR RESALE

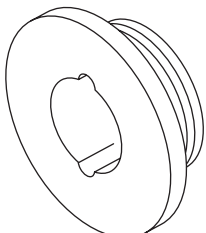
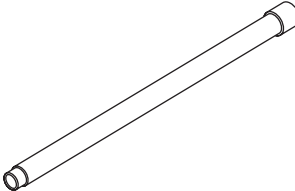
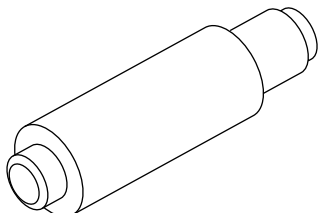
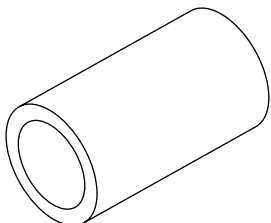
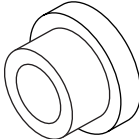
ILLUSTRATION	TOOL NUMBER	DESCRIPTION	REMARKS
 ST34199AG060	34199AG060	GUIDE G (26)	<ul style="list-style-type: none"> • Used for forming seal ring of rack. • Used together with the FORMER PISTON (34199AG080).
 ST34099PA010	34099PA010	OIL SEAL REMOVER	Used for removing oil seal.
 ST34199AG090	34199AG090	INSTALLER & REMOVER	<ul style="list-style-type: none"> • Used for installing oil seal of valve housing. • Used for installing ball bearing of valve housing. • Used for removing oil seal and ball bearing from valve housing.
 ST34199AG080	34199AG080	FORMER PISTON	<ul style="list-style-type: none"> • Used for forming seal ring of rack. • Used together with the GUIDE G (26) (34199AG060).
 ST34199AG010	34199AG010	INSTALLER	Used for pressing-fit oil seal of gearbox cylinder.

General Description

POWER ASSISTED SYSTEM (POWER STEERING)

Brought to you by Eris Studios
NOT FOR SALE

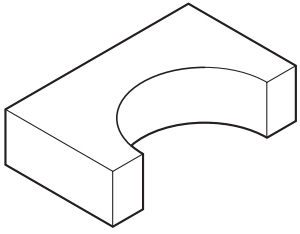
ILLUSTRATION	TOOL NUMBER	DESCRIPTION	REMARKS
 <p data-bbox="324 514 462 541">ST34199XA050</p>	34199XA050	BASE	Used for crimping.

Steering Wheel

POWER ASSISTED SYSTEM (POWER STEERING)

Brought to you by Eris Studios
NOT FOR RESALE

2. Steering Wheel

A: REMOVAL

- 1) Disconnect the ground cable from battery.
- 2) Set the tire to the straight-ahead position.
- 3) Remove the airbag module. <Ref. to AB-16, REMOVAL, Driver's Airbag Module.>

WARNING:

Always refer to "Airbag System" before performing service on the airbag modules. <Ref. to AB-5, CAUTION, General Description.>

- 4) Place alignment marks on the steering wheel and steering shaft.

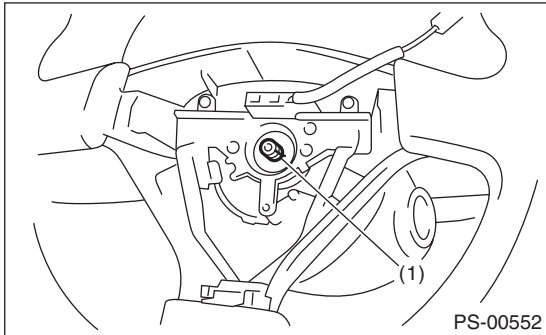

(1) Alignment mark

- 5) Remove the steering wheel nut, and then draw out the steering wheel from shaft using steering puller.

B: INSTALLATION

WARNING:

Always refer to "Airbag System" before performing service on the airbag modules. <Ref. to AB-5, CAUTION, General Description.>

- 1) Align the center position of the roll connector. <Ref. to AB-28, ADJUSTMENT, Roll Connector.>
- 2) Install in the reverse order of removal.

NOTE:

Align the alignment marks on the steering wheel and steering shaft.

Tightening torque:

39 N·m (4.0 kgf·m, 28.8 ft·lb)

Column cover-to-steering wheel clearance:

2 — 4 mm (0.08 — 0.16 in)

CAUTION:

Insert the roll connector guide pin into the guide hole on the lower end of the steering wheel surface. Avoid damaging the pin.

C: INSPECTION

- 1) Check the steering wheel for deformation. If the deformation is excessive, replace the steering wheel.
- 2) Check the splines on the steering wheel for damage. If the damage is excessive, replace the steering wheel.

Universal Joint

POWER ASSISTED SYSTEM (POWER STEERING)

Brought to you by Eris Studios
NO RESALE

3. Universal Joint

A: REMOVAL

- 1) Remove the steering wheel. <Ref. to PS-12, REMOVAL, Steering Wheel.>
- 2) Place alignment marks on universal joint.
- 3) Remove the universal joint bolt and remove the universal joint.

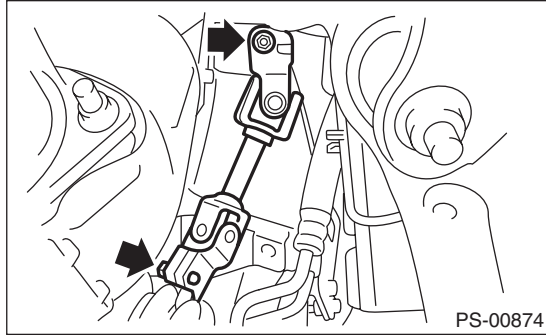

B: INSTALLATION

- 1) Align the cutout portion at serrated section of the column shaft and yoke, then install the universal joint into column shaft.

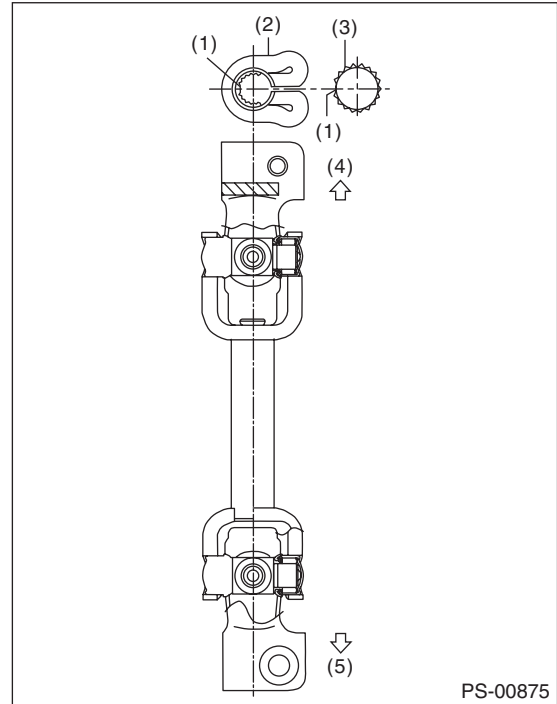

- (1) Cutout portion
- (2) Yoke
- (3) Column shaft
- (4) Column shaft side
- (5) Gearbox side

- 2) Install the universal joint to the serrations of gearbox assembly by matching alignment marks.
- 3) Tighten the bolts.

Tightening torque:

24 N·m (2.4 kgf-m, 17.4 ft-lb)

CAUTION:

Excessively large tightening torque of universal joint bolts may lead to heavy steering wheel operation.

Clearance between coupling of universal joint and turbo cover:

15 mm (0.59 in) or more

- 4) Align the center position of the roll connector. <Ref. to AB-28, ADJUSTMENT, Roll Connector.>
- 5) Install the steering wheel. <Ref. to PS-12, INSTALLATION, Steering Wheel.>

Universal Joint

POWER ASSISTED SYSTEM (POWER STEERING)

Brought to you by Eris Studios
NOT FOR RESALE

C: INSPECTION

1) Check for wear, damage or any other faults. Replace as necessary.

Service limit:

Universal joint play: 0 mm (0 in)

Maximum swing torque: 0.3 N (0.03 kgf, 0.07 lbf)

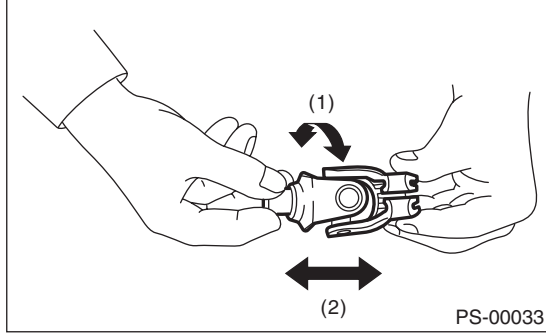

- (1) Swing torque
- (2) Play

2) Measure the swing torque of universal joint.

Service limit:

Maximum load: 3.8 N (0.39 kgf, 0.86 lbf) or less

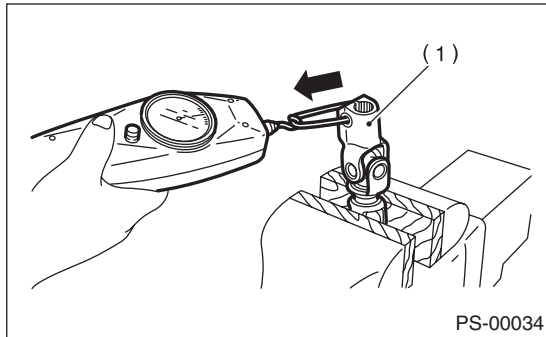

- (1) Yoke (Gearbox side)

Service limit:

Maximum load: 3.8 N (0.39 kgf, 0.86 lbf) or less

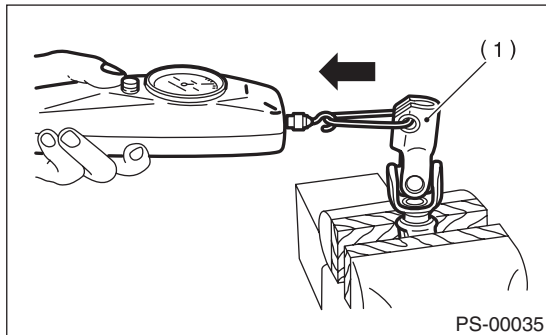

- (1) Yoke (Gearbox side)

Service limit:

Maximum load: 7.3 N (0.74 kgf, 1.64 lbf) or less

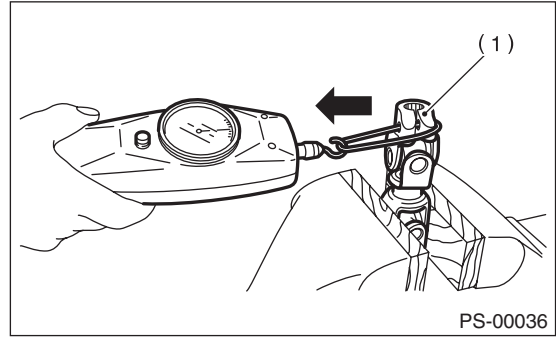

- (1) Yoke (Steering column side)

Service limit:

Maximum load: 7.3 N (0.74 kgf, 1.64 lbf) or less

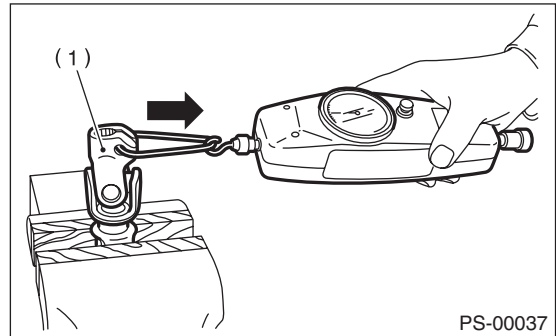

- (1) Yoke (Steering column side)

4. Steering Column

A: REMOVAL

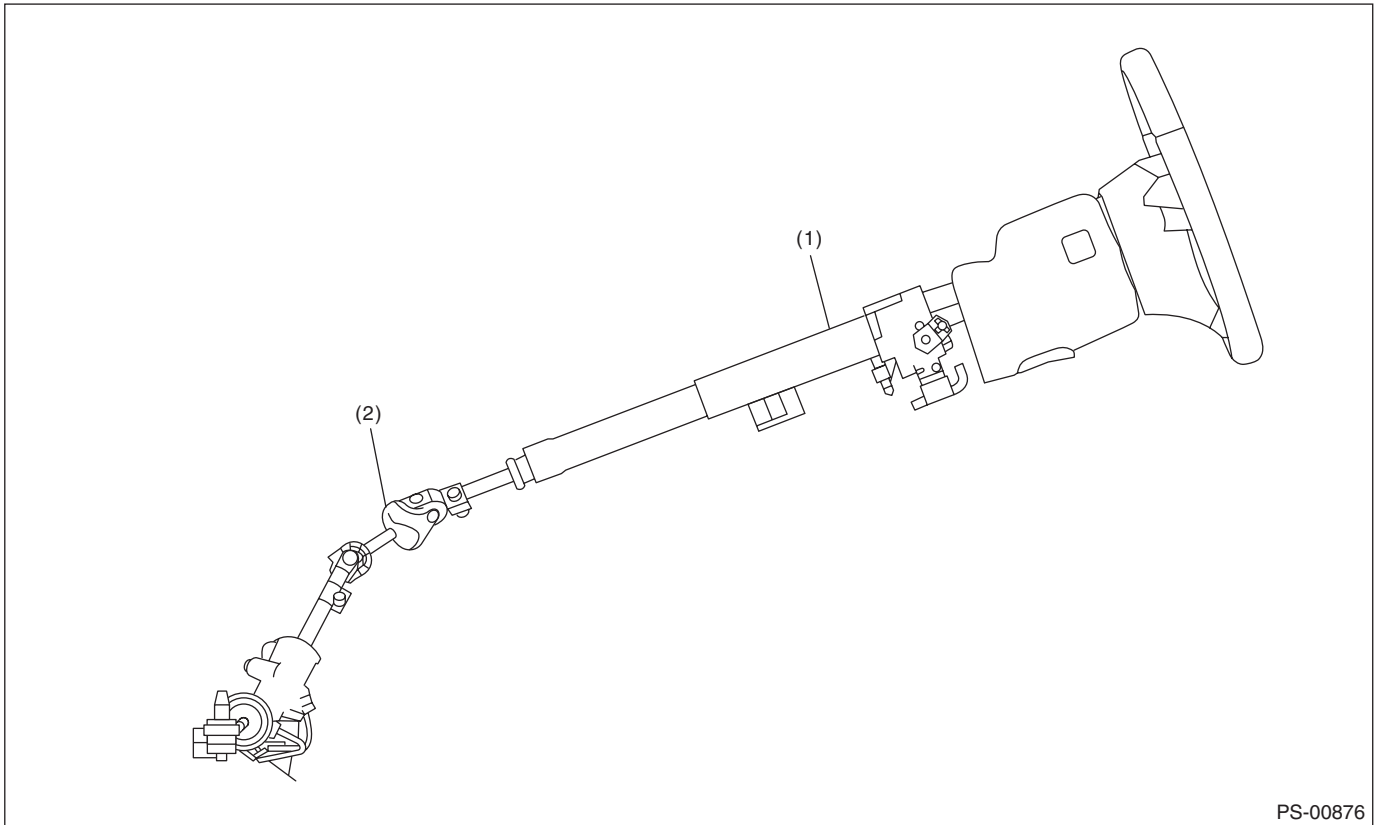

PS-00876

- (1) Tilt & telescopic steering column (2) Universal joint

- 1) Remove the steering wheel. <Ref. to PS-12, REMOVAL, Steering Wheel.>
- 2) Remove the universal joint. <Ref. to PS-13, REMOVAL, Universal Joint.>
- 3) Remove the instrument panel lower cover under.
- 4) Remove the instrument panel lower cover upper.
- 5) Remove all connectors from the steering column.
- 6) Remove the two bolts under instrument panel securing the steering column.

- 7) Pull out the steering shaft assembly from the hole on toe board.

CAUTION:

- Be sure to remove the universal joint before removing steering shaft assembly installing bolts when removing steering shaft assembly or when lowering it for servicing other parts.
- Do not loosen the tilt lever when the steering column is not secured to the vehicle.

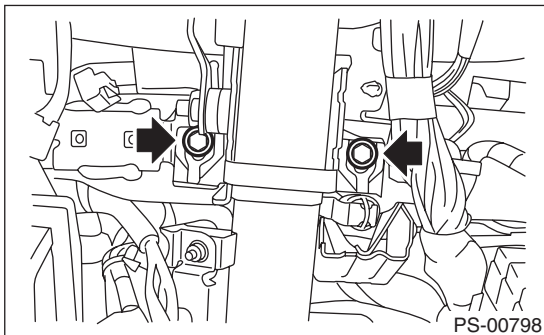

PS-00798

Steering Column

POWER ASSISTED SYSTEM (POWER STEERING)

Brought to you by Eris Studios
NOT FOR RESALE

B: INSTALLATION

1) Install the grommet to the toe board.

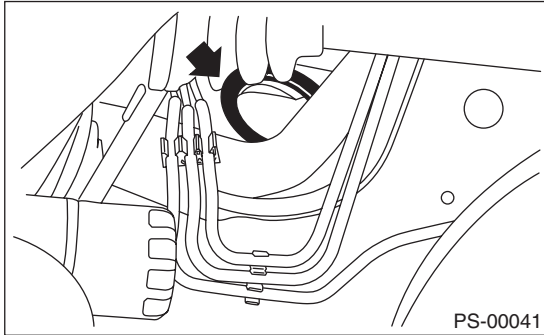

2) Insert the end of the steering shaft into the toe board grommet.

3) With the tilt lever secured, tighten the steering shaft mounting bolts under instrument panel.

Tightening torque:

25 N·m (2.5 kgf·m, 18.4 ft·lb)

4) Connect all the connectors under the instrument panel.

5) Connect the airbag system connector at the harness spool.

NOTE:

Make sure to apply double lock.

6) Install the instrument panel lower cover with tilt lever held in the lowered position.

7) Install the universal joint. <Ref. to PS-13, INSTALLATION, Universal Joint.>

8) Align the center position of the roll connector. <Ref. to AB-28, ADJUSTMENT, Roll Connector.>

9) Install the steering wheel. <Ref. to PS-12, INSTALLATION, Steering Wheel.>

CAUTION:

Insert the roll connector guide pin into the guide hole on lower end of steering wheel surface to prevent damage.

C: DISASSEMBLY

Remove the two screws securing the upper steering column covers, and the two screws securing the combination switch, and then remove related parts.

D: ASSEMBLY

Insert the combination switch to the upper column shaft, and install the upper column cover. Then route the ignition key harness and combination switch harness between the column cover mounting bosses.

Tightening torque:

1.2 N·m (0.12 kgf·m, 0.9 ft·lb)

CAUTION:

Do not overtorque the screw.

E: INSPECTION

1. BASIC INSPECTION

Measure the overall length of steering column. If not within specification, replace it.

Standard: Overall length L

**Tilt & telescopic column
(measure while minimized)**

$818.6^{+1.5}_{-1.5}$ mm ($32.23^{+0.059}_{-0.059}$ in)

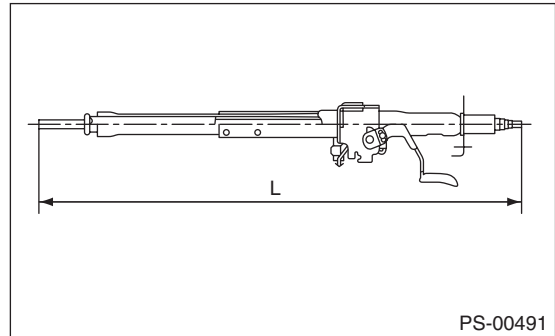

2. INSPECTION OF AIRBAG SYSTEM

Refer to "Airbag System" for airbag inspection procedures. <Ref. to AB-16, INSPECTION, Driver's Airbag Module.>

Steering Gearbox

POWER ASSISTED SYSTEM (POWER STEERING)

5. Steering Gearbox

A: REMOVAL

- 1) Set the vehicle on a lift.
- 2) Disconnect the ground cable from the battery.
- 3) Loosen the front wheel nuts.
- 4) Lift up the vehicle, and remove the front wheels.
- 5) Remove the under cover. <Ref. to EI-23, REMOVAL, Front Under Cover.>
- 6) After pulling off the cotter pin and removing the castle nut, use a puller to remove the tie-rod end from the knuckle arm.

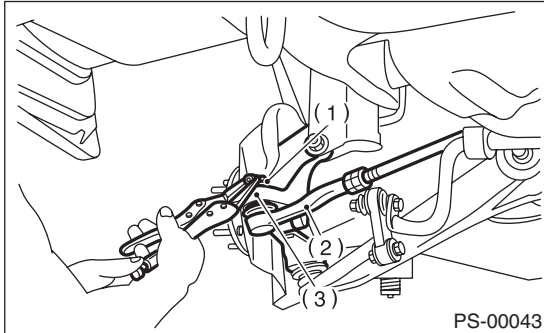

- (1) Castle nut
- (2) Tie-rod end
- (3) Knuckle arm

- 7) Remove the front crossmember support plate and front stabilizer. <Ref. to FS-15, REMOVAL, Front Stabilizer.>

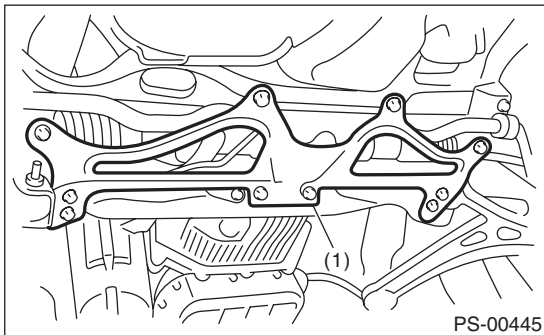

- (1) Front crossmember support plate

- 8) Remove the one pipe joint at the center of the gearbox, and connect the vinyl hose to the pipe and the joint. Discharge the fluid by turning the steering wheel fully clockwise and counterclockwise. Discharge the fluid similarly from other pipes.

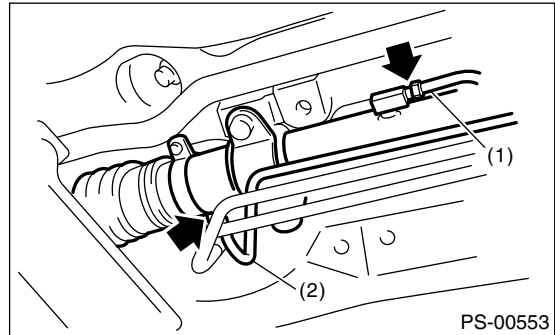

- (1) Pipe A
- (2) Pipe B

- 9) Remove the universal joint. <Ref. to PS-13, REMOVAL, Universal Joint.>
- 10) Disconnect the pipe C from pressure hose first, then disconnect pipe D from the return hose.

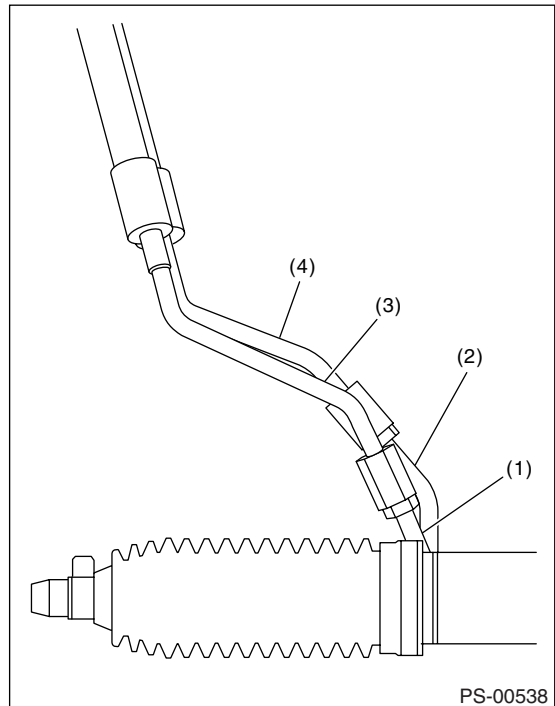

- (1) Pipe C
- (2) Pipe D
- (3) Pressure hose
- (4) Return hose

Steering Gearbox

Brought to you by Eris Studios
NOT FOR RESALE

POWER ASSISTED SYSTEM (POWER STEERING)

11) Remove the clamp bolts securing the gearbox to the crossmember, and remove the clamp.

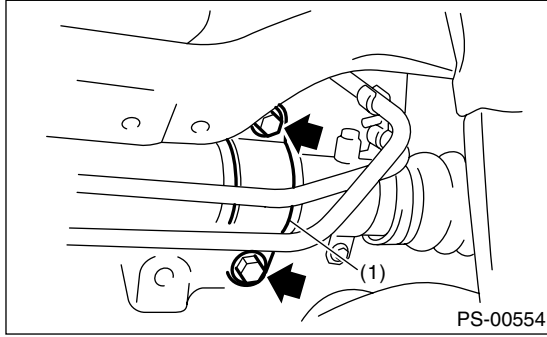

(1) Clamp

12) Remove the bolts which secure the gearbox bracket, and remove the bracket and gearbox.

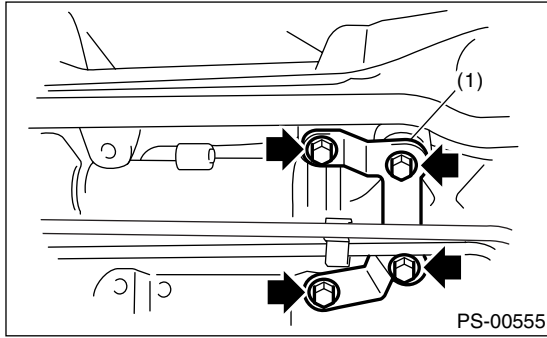

(1) Bracket

B: INSTALLATION

- 1) Insert the gearbox into crossmember, being careful not to damage gearbox boot.
- 2) Install the gearbox and bracket. Temporarily tighten the bolts.

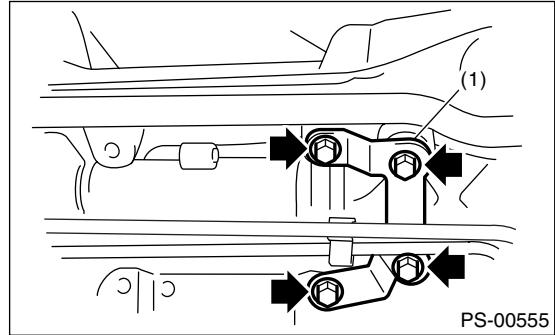

(1) Bracket

- 3) Insert bolts through the clamp to temporarily tighten the gearbox to the crossmember bracket.

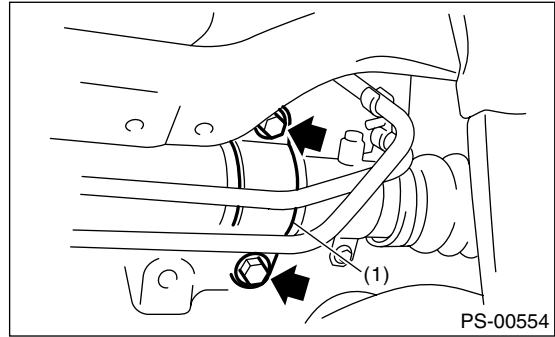

(1) Clamp

- 4) Tighten the bolts temporarily holding the gearbox clamp and bracket together to the specified torque.

Tightening torque:

60 N·m (6.1 kgf-m, 44.1 ft-lb)

Steering Gearbox

POWER ASSISTED SYSTEM (POWER STEERING)

5) Connect pipe D to the return hose, then connect pipe C to the pressure hose.

Tightening torque:

15 N·m (1.5 kgf·m, 10.8 ft·lb)

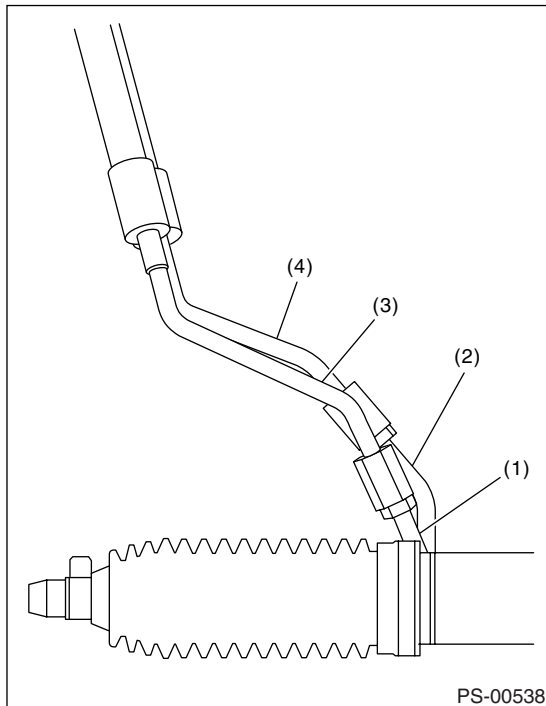

- (1) Pipe C
- (2) Pipe D
- (3) Pressure hose
- (4) Return hose

6) Install the universal joint. <Ref. to PS-13, INSTALLATION, Universal Joint.>

7) Connect the tie-rod end and knuckle arm, and tighten with castle nut.

Castle nut tightening torque:

27 N·m (2.75 kgf·m, 19.9 ft·lb)

CAUTION:

When connecting, do not hit the cap at the bottom of tie-rod end with hammer.

8) After tightening the castle nut to the specified tightening torque, tighten it further within 60° until the cotter pin hole is aligned with slot in the nut. Fit the cotter pin into the nut, and then bend the pin to lock.

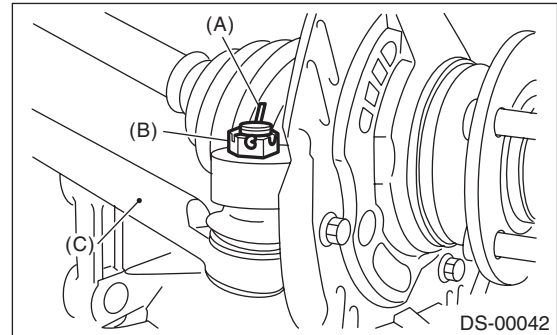

- (A) Cotter pin
- (B) Castle nut
- (C) Tie-rod end

9) Install the front stabilizer. <Ref. to FS-15, INSTALLATION, Front Stabilizer.>

10) Install the front crossmember support plate.

11) Install the under cover. <Ref. to EI-23, INSTALLATION, Front Under Cover.>

12) Install the front wheels.

13) Tighten the wheel nuts to the specified torque.

Tightening torque:

100 N·m (10.2 kgf·m, 73.8 ft·lb)

14) Lower the vehicle.

15) Remove the steering wheel. <Ref. to PS-12, REMOVAL, Steering Wheel.>

16) Align the center position of the roll connector. <Ref. to AB-28, ADJUSTMENT, Roll Connector.>

17) Install the steering wheel. <Ref. to PS-12, INSTALLATION, Steering Wheel.>

18) Connect the ground cable to the battery.

19) Pour fluid into the oil tank, and perform air bleeding. <Ref. to PS-51, Power Steering Fluid.>

20) Check for fluid leaks.

21) Check the fluid level in oil tank.

Steering Gearbox

POWER ASSISTED SYSTEM (POWER STEERING)

22) After adjusting toe-in and steering angle, tighten the lock nut on tie-rod end.

Tightening torque:

85 N·m (8.7 kgf·m, 62.7 ft·lb)

NOTE:

When adjusting toe-in, hold the boot as shown to prevent it from being rotated or twisted. If it becomes twisted, straighten it.

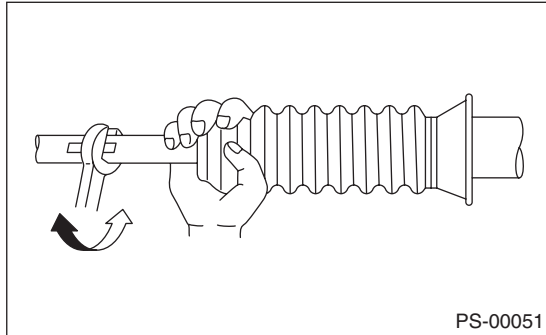

C: DISASSEMBLY

1. RACK HOUSING ASSEMBLY

1) Disconnect the four pipes from gearbox.

NOTE:

Remove the pipes C and D, which are fixed to clamp plate, as a unit.

2) Secure the gearbox removed from vehicle in a vise using ST.

ST1 926200000 STAND

ST2 34199AG000 BOSS D

CAUTION:

Secure the gearbox in a vise using ST as shown in the figure. Do not secure the gearbox without this ST.

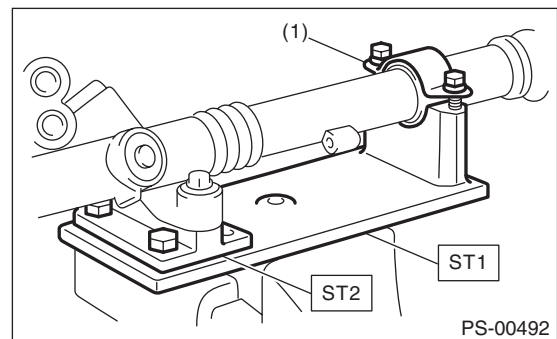

(1) Clamp

3) Remove the tie-rod end and lock nut from gearbox.

4) Remove the small clip from the boot using pliers, and then move the boot to tie-rod end side.

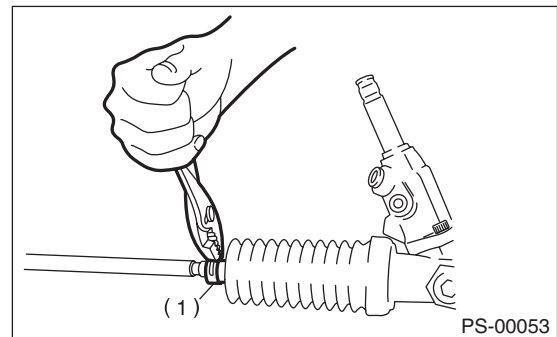

(1) Clip

Steering Gearbox

POWER ASSISTED SYSTEM (POWER STEERING)

Brought to you by Eris Studios
NOT FOR SALE

5) Using a flat tip screwdriver, remove the band from boot.

NOTE:

Replace the boot if there is damage, cracks or deterioration.

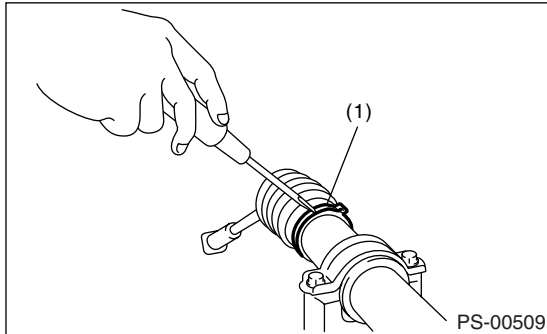

(1) Band

6) Using the ST, loosen the lock nut.
ST 926230000 SPANNER

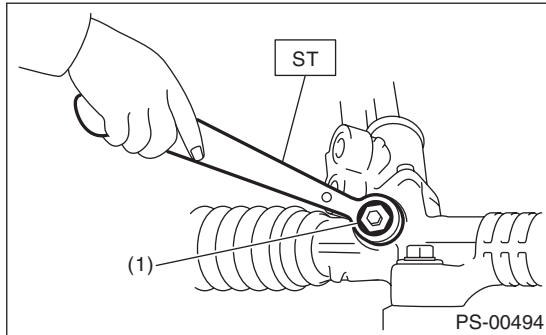

(1) Lock nut

7) Tighten the adjusting screw until it can no longer be tightened.

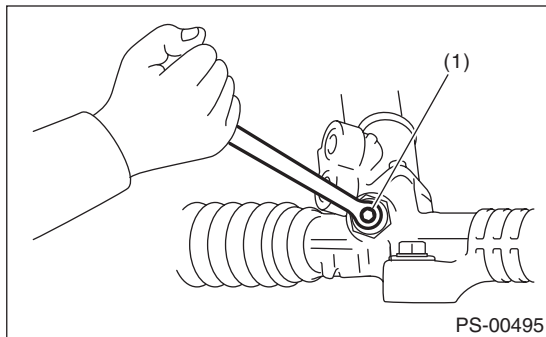

(1) Adjusting screw

8) Remove the tie-rod.

9) Loosen the adjusting screw, and remove the spring and sleeve.

10) Remove the two bolts securing valve assembly.

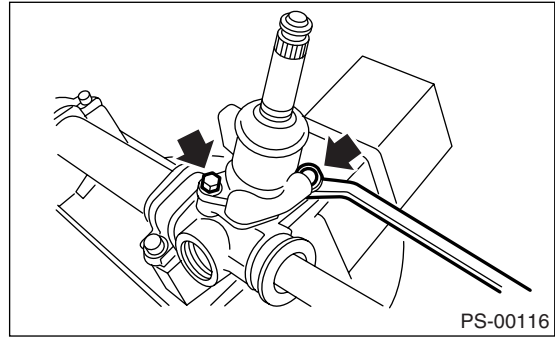

11) Carefully draw out the input shaft and remove the valve assembly.

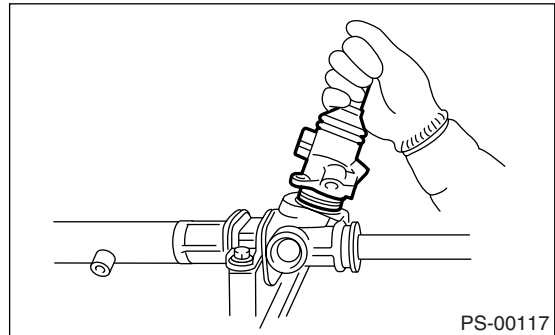

12) Using a drill, release the crimping of holder.

CAUTION:

Make a hole of 2 mm (0.08 in) depth using a drill with 3 mm (0.12 in) diameter.

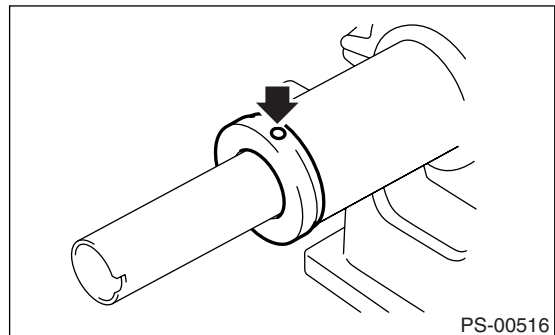

13) Remove the holder.

Steering Gearbox

Brought to you by Eris Studios
NOT FOR RESALE

POWER ASSISTED SYSTEM (POWER STEERING)

14) Attach the ST to the pinion housing side of the rack, and push out the rack together with the outer side oil seal.

ST 34199FE000 INSTALLER & REMOVER

NOTE:

Block the pipe connection of the steering body to prevent fluid from flowing out.

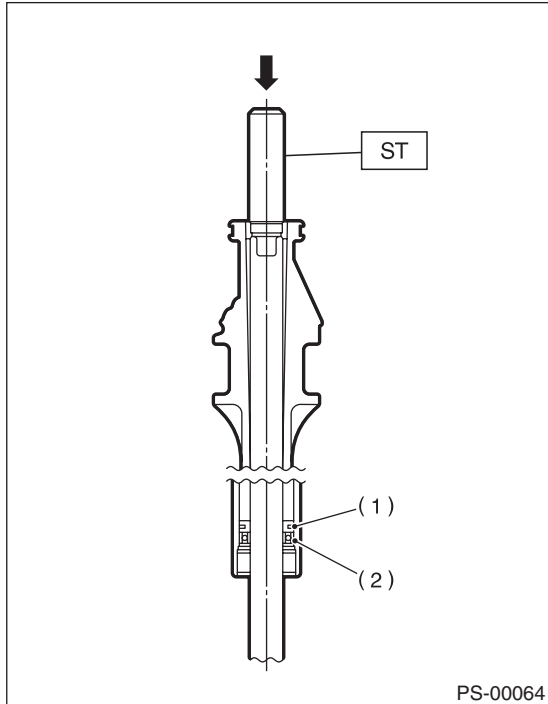

- (1) Rack piston
- (2) Outer side oil seal

15) Insert the ST from pinion housing side and remove the oil seal using a press.

ST 34099PA010 OIL SEAL REMOVER

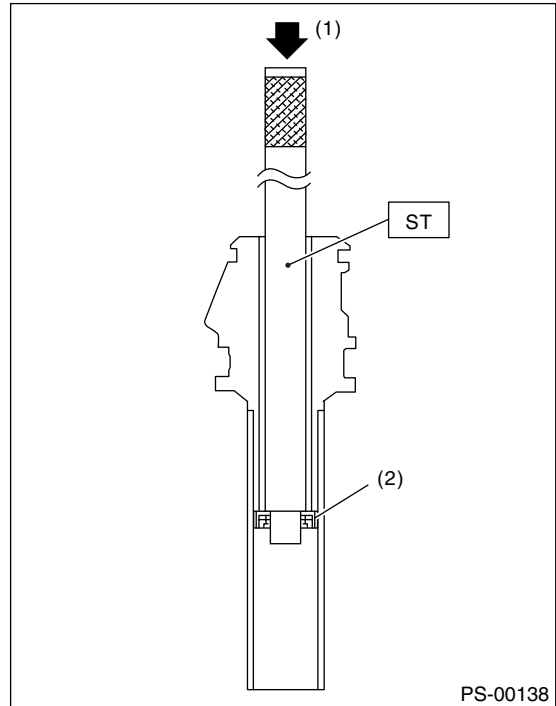

- (1) Press
- (2) Oil seal

16) Using a press, remove the bushing of gearbox installation portion.

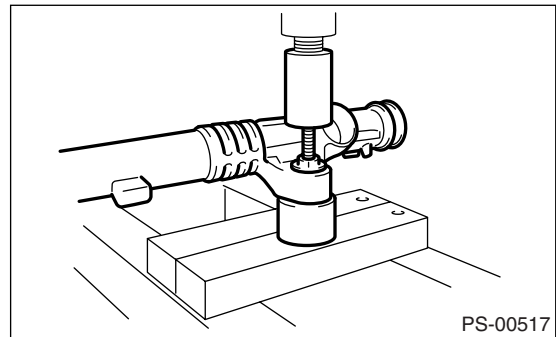

Steering Gearbox

POWER ASSISTED SYSTEM (POWER STEERING)

Brought to you by Eris Studios
NOT FOR SALE

2. CONTROL VALVE

- 1) Disconnect the pipes A and B from gearbox.
- 2) Secure the gearbox removed from vehicle in a vise using ST.

ST1 92620000 STAND
ST2 34199AG000 BOSS D

CAUTION:

Secure the gearbox in a vise using ST as shown in the figure. Do not secure the gearbox without this ST.

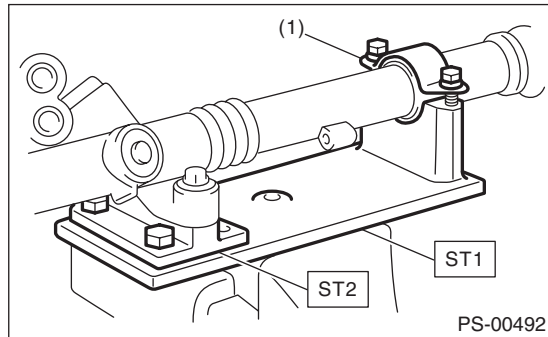

(1) Clamp

- 3) Using the ST, loosen the lock nut.
ST 926230000 SPANNER

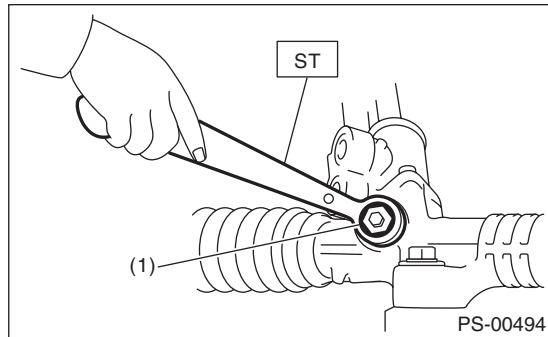

(1) Lock nut

- 4) Tighten the adjusting screw until it can no longer be tightened.

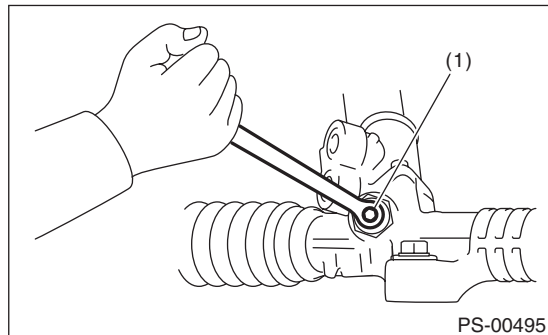

(1) Adjusting screw

- 5) Loosen the adjusting screw, and remove the spring and sleeve.

- 6) Remove the two bolts securing valve assembly.

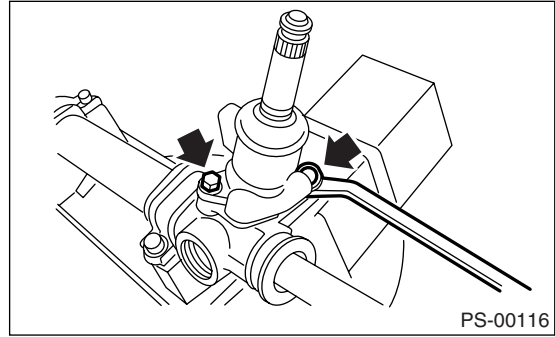

- 7) Carefully draw out the input shaft and remove the valve assembly.

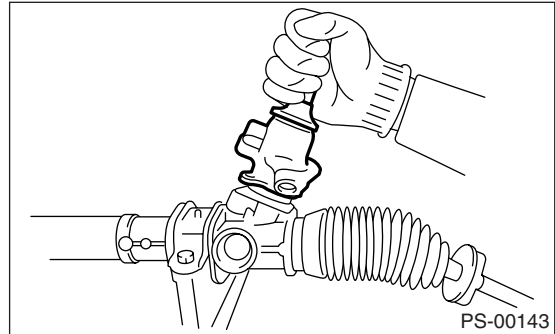

- 8) Put a vinyl tape around the spline portion, and slide the dust cover to remove.

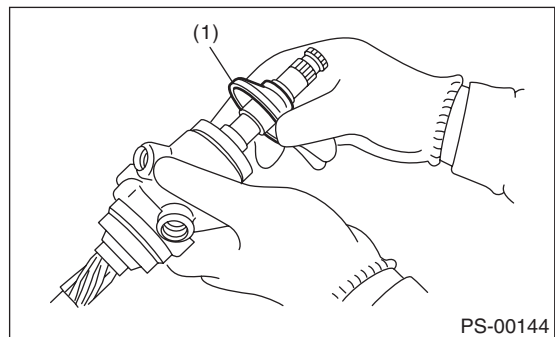

(1) Dust cover

- 9) Using a press, remove the pinion & valve assembly from valve housing.

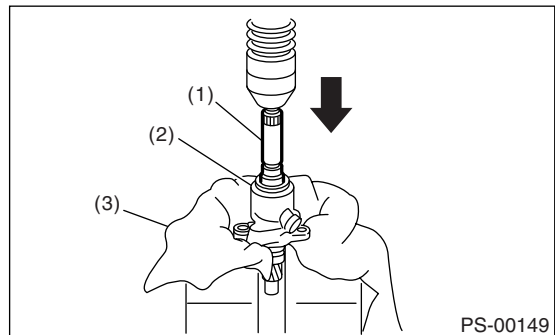

- (1) Pinion & valve ASSY
- (2) Valve housing
- (3) Cloth

Steering Gearbox

Brought to you by Eris Studios
NOT FOR RESALE

POWER ASSISTED SYSTEM (POWER STEERING)

10) Using the ST and a press, remove the bushing and oil seal from the valve housing.

ST 34199AG090 INSTALLER & REMOVER

CAUTION:

- Do not apply a force to the end surface of valve housing.
- Do not reuse the oil seal after removal.

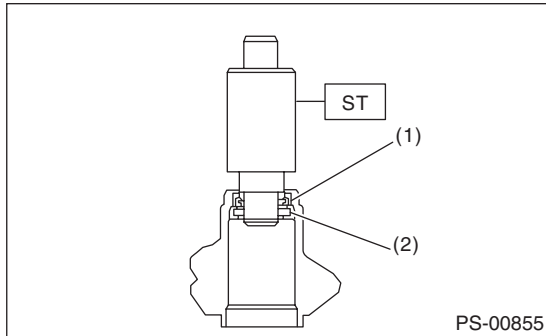

- (1) Oil seal
- (2) Bushing

11) Using a snap ring pliers, remove the snap ring, valve, oil seal and back-up washer.

CAUTION:

Be careful not to scratch the pinion and valve assembly.

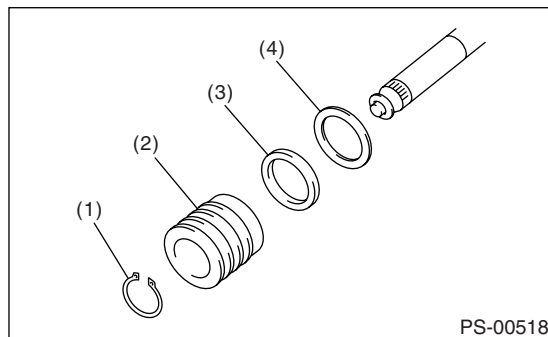

- (1) Snap ring
- (2) Valve
- (3) Oil seal
- (4) Back-up ring

D: ASSEMBLY

1. RACK HOUSING ASSEMBLY

1) Using a press, install the bushing to gearbox installation portion.

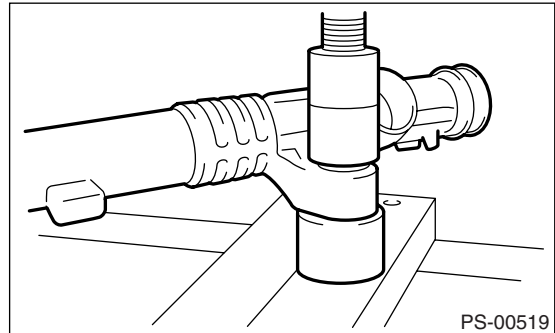

2) Insert the ST to rack.

ST 34199AG040 GUIDE

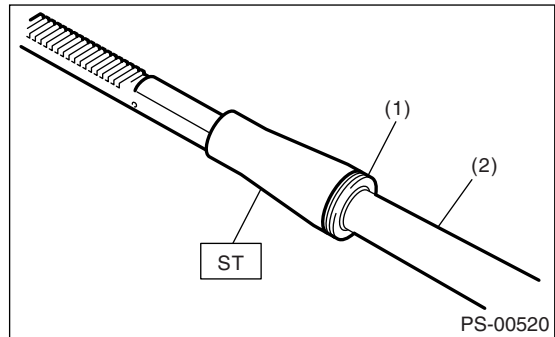

- (1) Seal ring
- (2) Rack

3) Install the seal ring to piston portion of rack.

4) Using the ST, form the seal ring properly.

ST1 34199AG080 FORMER PISTON

ST2 34199AG060 GUIDE G (26)

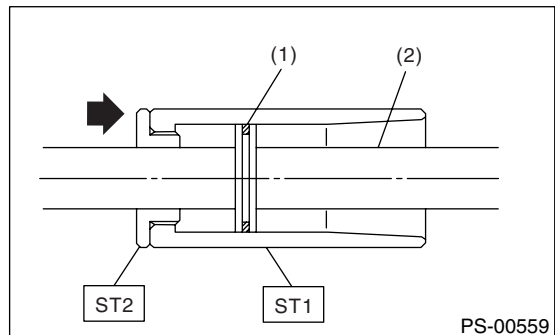

- (1) Seal ring
- (2) Rack

Steering Gearbox

POWER ASSISTED SYSTEM (POWER STEERING)

Brought to you by Eris Studios
NOT FOR SALE

5) Using the ST B and ST C, attach the oil seal to ST A.

ST 34199FE040 INSTALLER A, B, C

NOTE:

Face the oil seal in the direction as shown in the figure.

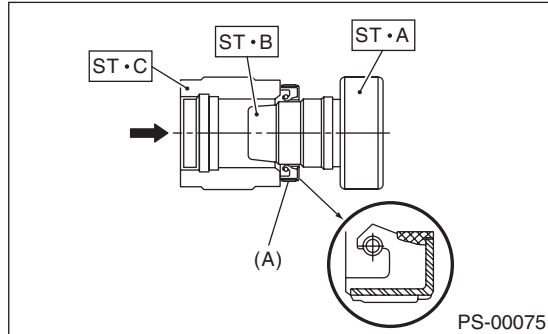

(A) Oil seal

6) Insert the ST A with oil seal assembled from the gear side of rack. Remove the oil seal from ST A near piston, and then remove the ST A from rack.

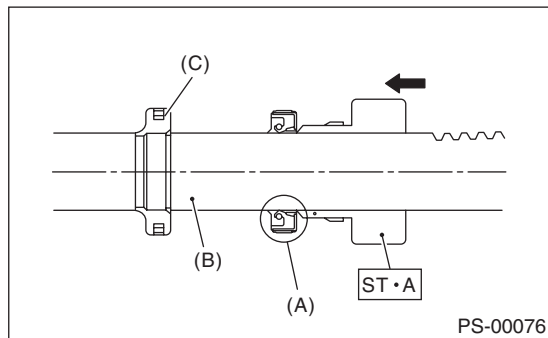

(A) Oil seal
(B) Rack
(C) Piston

7) Install the back-up washer from the gear side of rack.

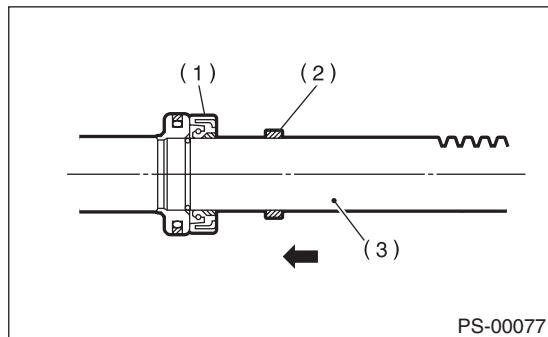

(1) Oil seal
(2) Back-up washer
(3) Rack

8) Check the threaded end of holder and gearbox cylinder end for burrs, damage, etc. Correct if faulty.

9) Apply a coat of grease to the grooves in rack, sliding surface of sleeve and sealing surface of piston. Then insert the rack into steering body from cylinder side.

10) Temporarily tighten the new holder to the gearbox cylinder.

11) Mark the position 15 mm (0.59 in) from the end surface of the ST as shown in the figure.

ST 34199FE000 INSTALLER & REMOVER

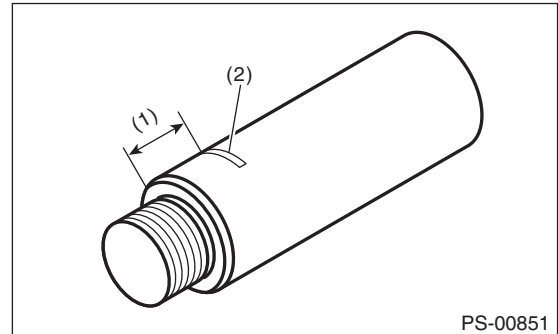

(1) 15 mm (0.59 in)
(2) Place a mark

12) Set the ST to the end of rack.

ST 34199FE000 INSTALLER & REMOVER

13) Using a press, press-fit until the mark on the ST is aligned with the end surface of the holder.

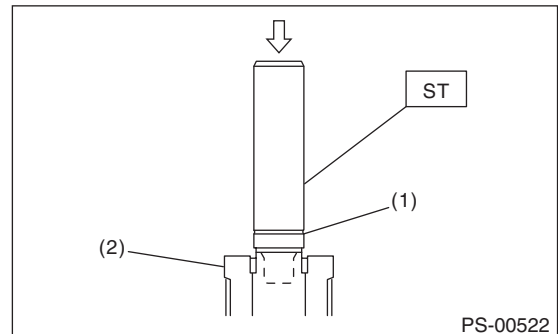

(1) Mark
(2) Holder

14) Remove the ST and holder.

15) Press-fit the outer side oil seal to the rack using the same procedures as shown in steps 5) and 6).

ST 34199FE040 INSTALLER A, B, C

Steering Gearbox

Brought to you by Eris Studios
NOT FOR RESALE

POWER ASSISTED SYSTEM (POWER STEERING)

16) Insert the ST and pipe into the rack, then press-fit the outer side oil seal using a press.

ST 34199AG010 INSTALLER

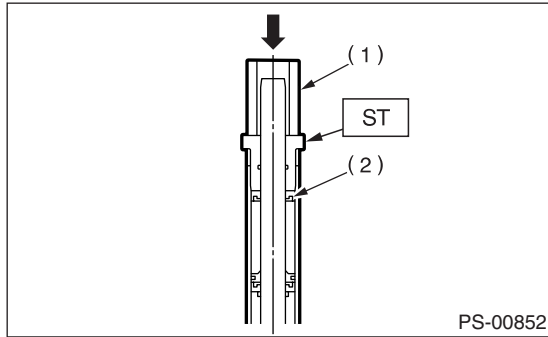

- (1) Pipe
- (2) Outer side oil seal

17) Secure the gearbox in a vise using ST.

ST1 926200000 STAND
ST2 34199AG000 BOSS D

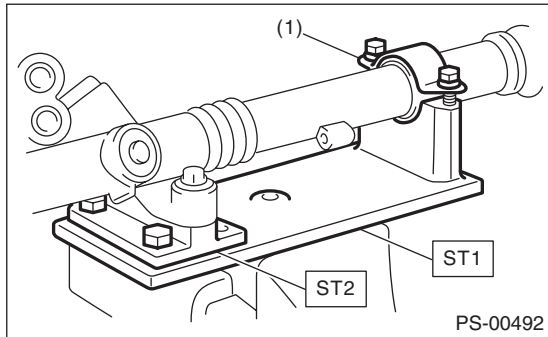

- (1) Clamp

18) Tighten the holder.

Tightening torque:

70 N·m (7.1 kgf·m, 51.6 ft·lb)

19) Using the ST, crimp so that the diameter of punch hole is 2 — 2.5 mm (0.08 — 0.10 in) and is aligned to the position of 2 mm (0.08 in) from gearbox cylinder end surface.

ST1 34099FA060 PUNCH HOLDER
ST2 34199XA050 BASE

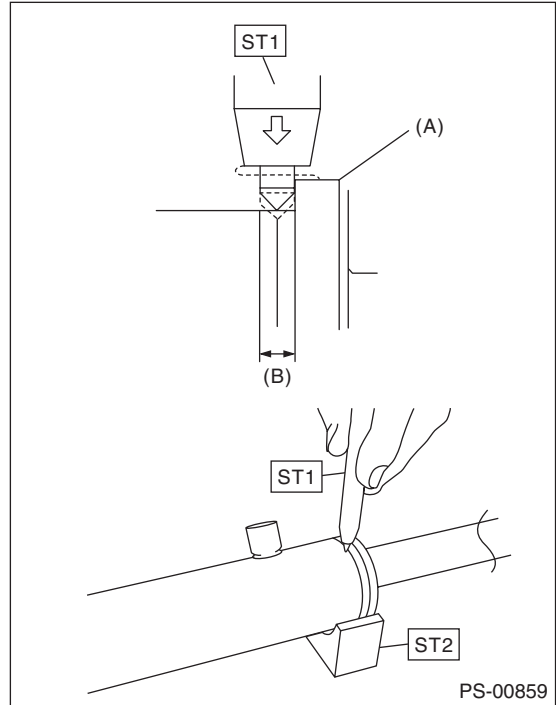

- (A) Holder
- (B) 2 mm (0.08 in)

20) Put a vinyl tape around the spline portion and apply genuine grease to the dust cover and install to valve assembly.

CAUTION:

Be sure to install the dust cover to groove of shaft.

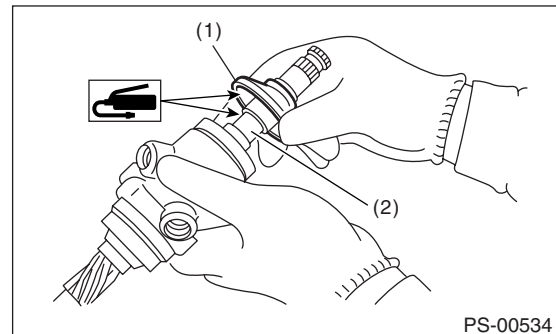

- (1) Dust cover
- (2) Groove

Steering Gearbox

POWER ASSISTED SYSTEM (POWER STEERING)

21) Apply the genuine grease to the pinion gear and bearing of valve assembly.

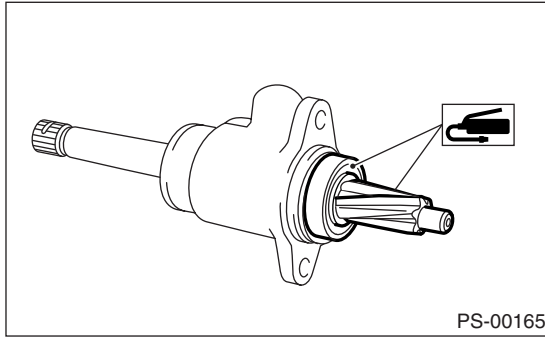

22) Install a new gasket on valve assembly. Insert the valve assembly into place while facing the rack teeth toward pinion.

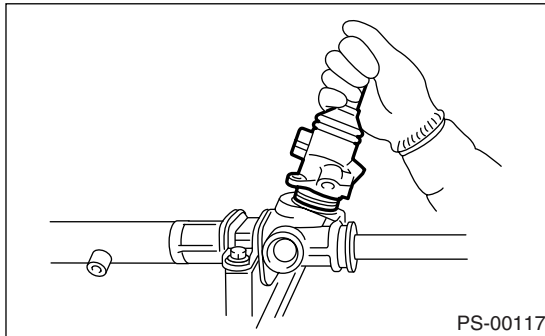

23) Tighten the bolts alternately to secure the valve assembly.

Tightening torque:

20 N·m (2.0 kgf·m, 14.8 ft·lb)

CAUTION:

Be sure to alternately tighten the bolts.

24) Temporarily install the tie-rod to rack end, and then operate the rack from lock to lock for two or three times to make it fit in.

CAUTION:

Operating the rack from lock to lock without installing tie-rods may damage the oil seal. Always install the left and right tie-rods.

25) Apply liquid gasket to 1/3 or more of entire perimeter of adjusting screw thread.

Liquid gasket:

THREE BOND 1141

26) Apply a coat of grease to the sliding surface of sleeve and seating surface of spring, and then insert the sleeve into steering body.

Charge the adjusting screw with grease, and then insert the spring into adjusting screw. Then install on the steering body.

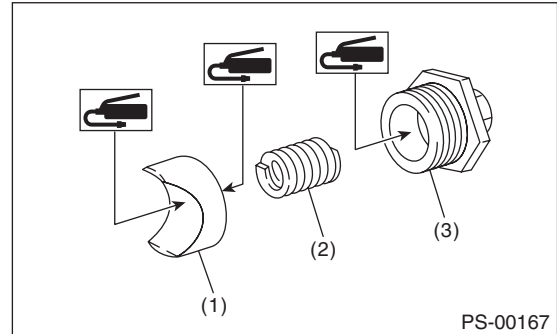

- (1) Sleeve
- (2) Spring
- (3) Adjusting screw

27) Tighten the adjusting screw to the specified torque, then loosen it.

Tightening torque:

25 N·m (2.5 kgf·m, 18.4 ft·lb)

28) Tighten the adjusting screw to the specified torque, then loosen it within 20°.

Tightening torque:

3.9 N·m (0.4 kgf·m, 2.9 ft·lb)

29) Remove the tie-rod.

30) Adjust the adjustment screw until the rotational resistance of gearbox is within specifications. <Ref. to PS-35, TURNING RESISTANCE OF GEARBOX, INSPECTION, Steering Gearbox.>

31) Apply liquid gasket to lock nut and install it into adjusting screw. While holding the adjusting screw with wrench, tighten the lock nut using ST.

Liquid gasket:

THREE BOND 1141

ST 926230000 SPANNER

Tightening torque (lock nut):

25 N·m (2.5 kgf·m, 18.1 ft·lb)

NOTE:

Hold the adjusting screw with a wrench to prevent it from turning while tightening lock nut.

32) Extend the rack approx. 40 mm (1.57 in) from steering body.

Steering Gearbox

Brought to you by Eris Studios
NOT FOR RESALE

POWER ASSISTED SYSTEM (POWER STEERING)

33) Install the tie-rod and new lock washer into rack.

Tightening torque:

90 N·m (9.1 kgf·m, 65.8 ft·lb)

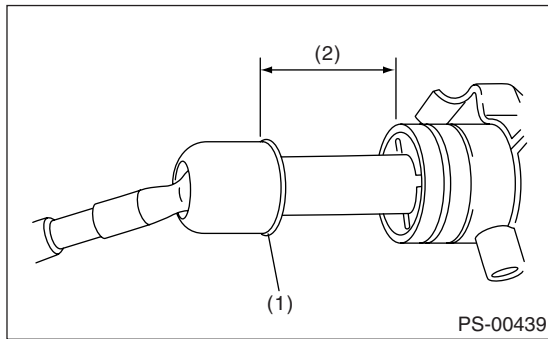

- (1) Lock washer
- (2) Approximately 40 mm (1.57 in)

34) Bend the lock washer and crimp it.

CAUTION:

Be careful not to scratch the rack when crimping lock washer.

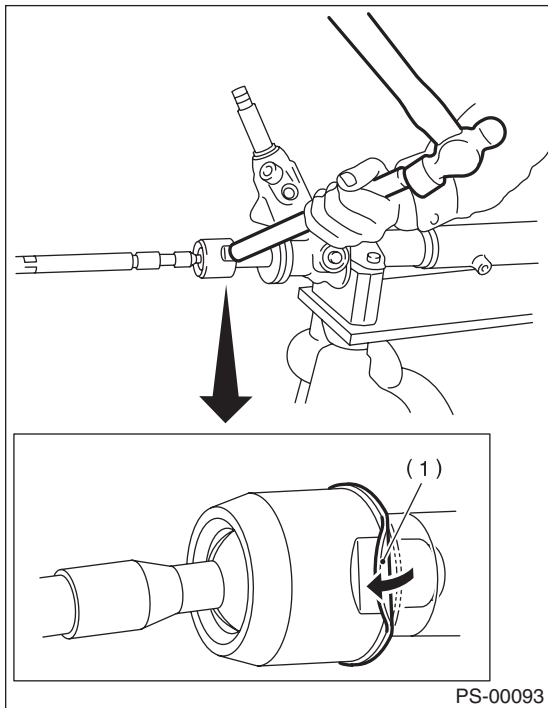

- (1) Lock washer

35) Apply a coat of grease to the tie-rod groove, and then install the boot to the housing.

CAUTION:

Right side boot has groove for identification, be sure to install the right and left of boot.

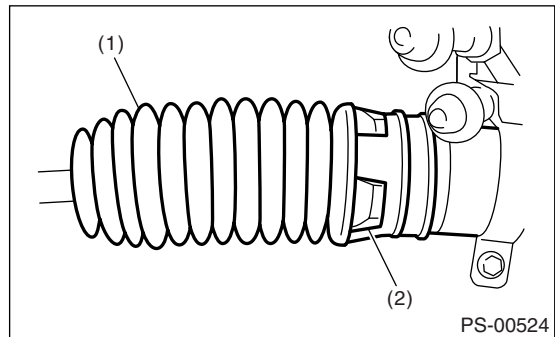

- (1) Right side boot
- (2) Groove for identification

NOTE:

Make sure that the boot is installed without unusual inflation or deflation.

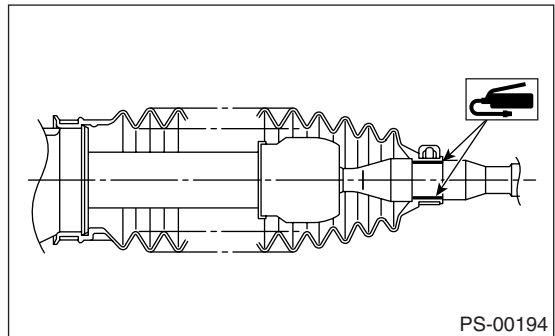

PS-00194

Steering Gearbox

POWER ASSISTED SYSTEM (POWER STEERING)

36) Install a new boot band. Using band clamp pliers, crimp it so that the clearance of crimping portion becomes 2 mm (0.079 in) or less.

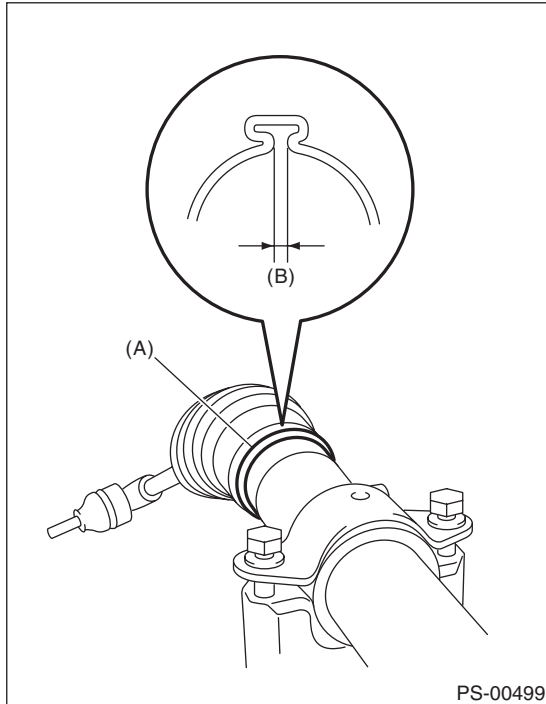

- (A) Boot band
- (B) 2 mm (0.079 in) or less

37) Fix the boot end with small clip.

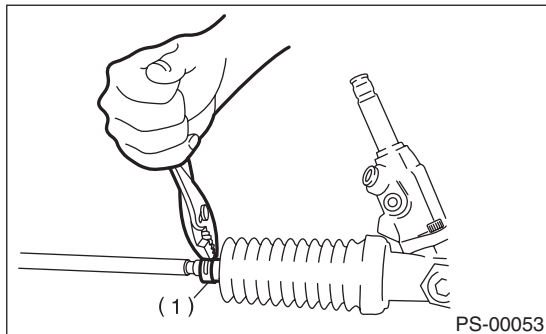

- (1) Clip

38) After installing, check that the boot end is installed to the groove of the tie-rod.

39) If the tie-rod end has been removed, screw in lock nut and tie-rod end to the screwed portion of tie-rod, and tighten the lock nut temporarily in a position as shown in the figure.

Installed tie-rod length L:
29 mm (1.14 in)

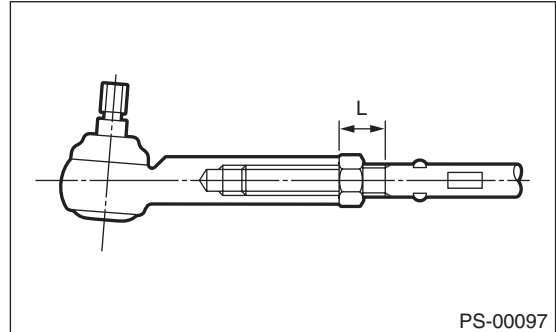

40) Inspect the gearbox as follows:
“A” Holding the tie-rod end, repeat lock to lock two or three times as quickly as possible.
“B” Holding the tie-rod end, turn it slowly at a radius one or two times as large as possible.
Finally, make sure that the boot is installed in the specified position without inflating.

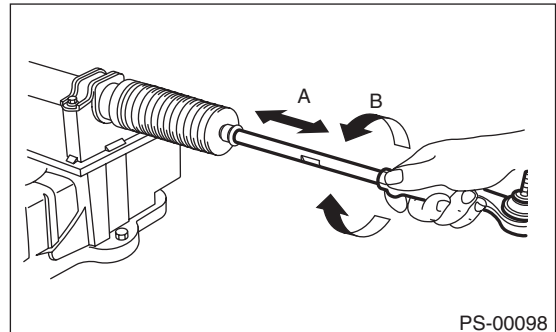

41) Remove the gearbox from ST.
ST1 92620000 STAND
ST2 34199AG000 BOSS D

Steering Gearbox

Brought to you by Eris Studios
NOT FOR RESALE

POWER ASSISTED SYSTEM (POWER STEERING)

- 42) Install the four pipes on gearbox.
(1) Connect the pipes A and B to the four pipe joints of gearbox.

Tightening torque:

Refer to the component parts. <Ref. to PS-4, POWER ASSISTED SYSTEM, COMPONENT, General Description.>

- (2) Connect the pipes C and D to gearbox.

Tightening torque:

Pipe D: 37 N·m (3.8 kgf-m, 27.3 ft-lb)

Pipe C: 29 N·m (3.0 kgf-m, 21.4 ft-lb)

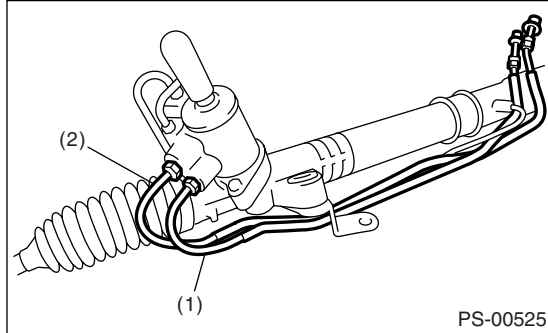

- (1) Pipe D
(2) Pipe C

PS-00525

2. CONTROL VALVE ASSEMBLY

Specified steering grease:

VALIANT GREASE M2 (Part No. 003608001)

- 1) Clean all parts and tools before reassembling.
- 2) Apply a coat of specified power steering fluid to the inner wall of valve housing.

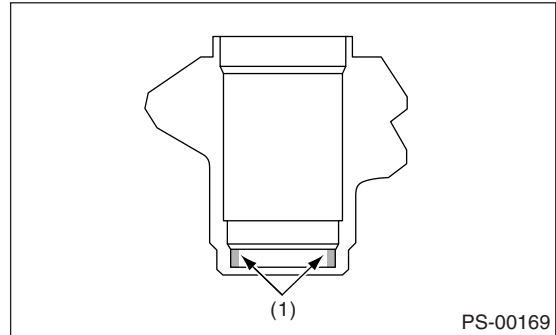

PS-00169

- (1) Apply fluid.

- 3) Apply grease to the oil seal.
- 4) Verify the direction of oil seal.
- 5) Using the ST and a press, install the oil seal and bushing to the valve housing.

ST 34199AG090 INSTALLER & REMOVER

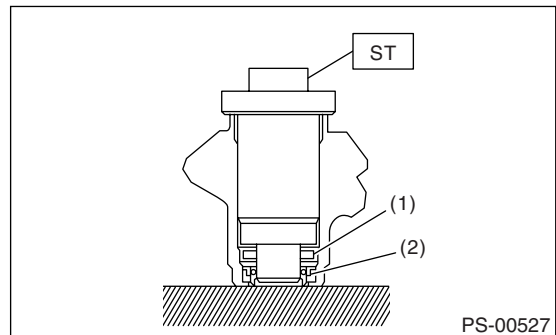

PS-00527

- (1) Bushing
(2) Oil seal

- 6) Apply vinyl tape to the groove of pinion.
- 7) Install the back-up ring and oil seal to pinion, and then remove the vinyl tape.

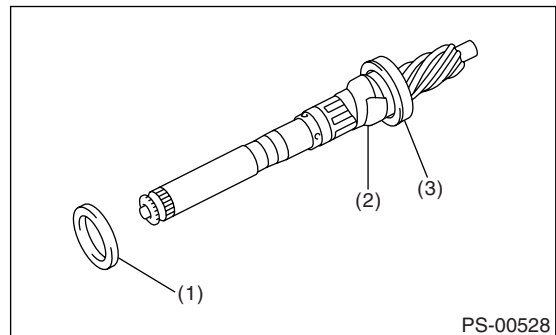

PS-00528

- (1) Oil seal
(2) Vinyl tape
(3) Back-up ring

Steering Gearbox

POWER ASSISTED SYSTEM (POWER STEERING)

Brought to you by Eris Studios
NO RESALE

8) Attach the ST to pinion, and install the seal ring.
ST 34199AG020 GUIDE

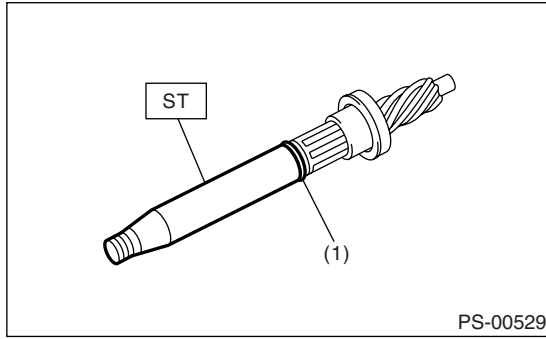

(1) Seal ring

12) Attach the pinion and valve assembly into the valve housing.

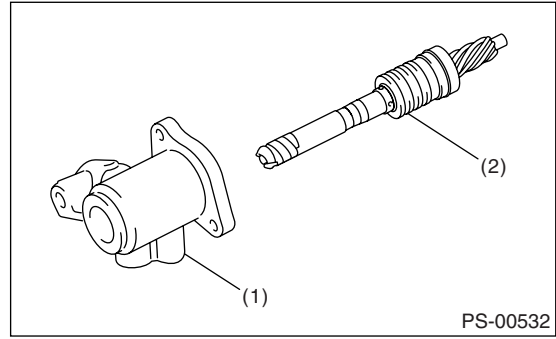

(1) Valve housing
(2) Pinion & valve ASSY

9) Remove the ST GUIDE, and form the seal ring properly using ST FORMER.
ST 34199AG070 FORMER

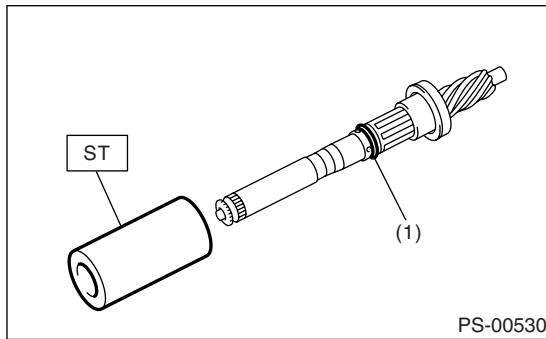

(1) Seal ring

13) Using a press, push the outer race of bearing and press-fit the pinion & valve assembly into housing.

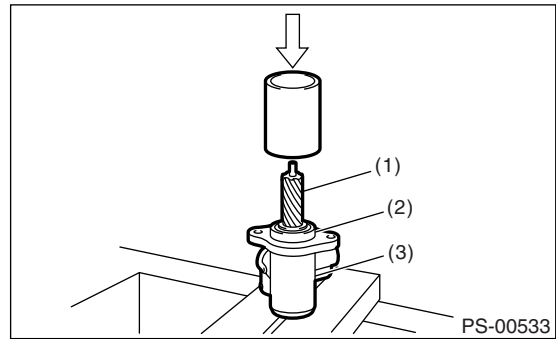

(1) Pinion & valve ASSY
(2) Bearing
(3) Housing

10) Put vinyl tape around pinion shaft spline to protect oil seal from damage.

11) Install the valve to pinion, and install the snap ring.

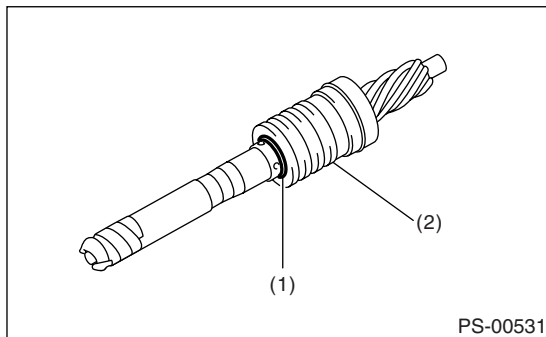

(1) Snap ring
(2) Valve

14) Apply the specified grease to dust cover.
15) Install the dust cover on valve assembly.

CAUTION:

Be sure to install the dust cover to groove of shaft.

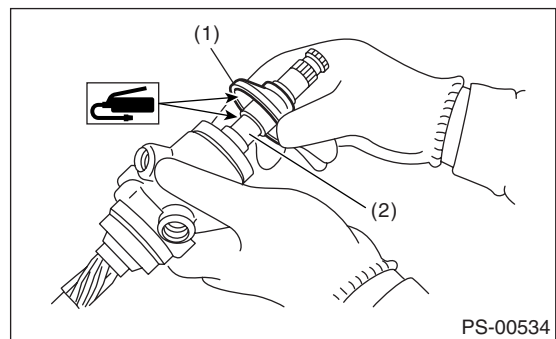

(1) Dust cover
(2) Groove

Steering Gearbox

POWER ASSISTED SYSTEM (POWER STEERING)

16) Apply the genuine grease to the pinion gear and bearing of valve assembly.

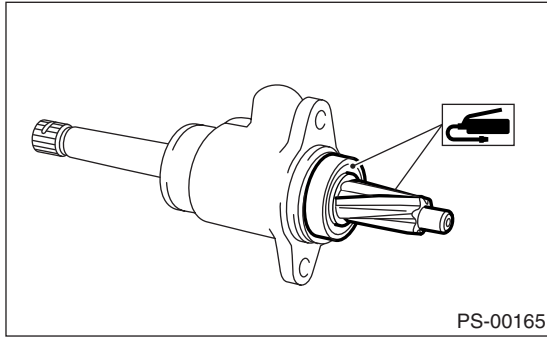

17) Install new O-ring to valve assembly.

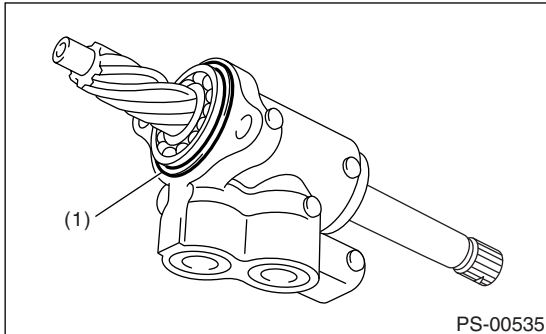

(1) O-ring

18) Insert the valve assembly into place while facing the rack teeth toward pinion.

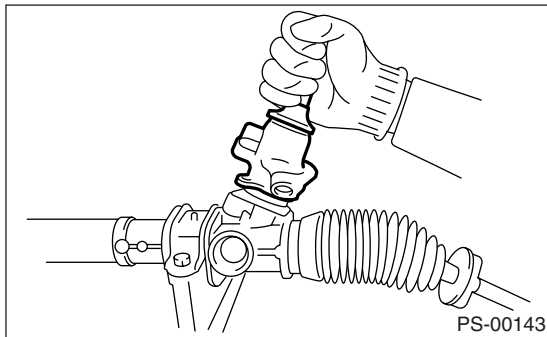

19) Tighten the bolts alternately to secure the valve assembly.

Tightening torque:

20 N-m (2.0 kgf-m, 14.8 ft-lb)

CAUTION:

Be sure to alternately tighten the bolts.

20) Apply liquid gasket to 1/3 or more of entire perimeter of adjusting screw thread.

Liquid gasket:

THREE BOND 1141 (Part No. 004403006)

21) Apply a coat of grease to the sliding surface of sleeve and seating surface of spring, and then insert the sleeve into steering body.

Charge the adjusting screw with grease, and then insert the spring into adjusting screw. Then install on the steering body.

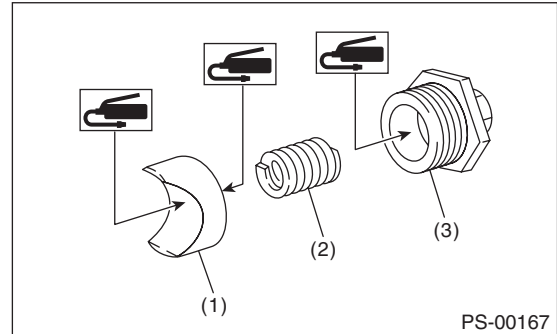

(1) Sleeve

(2) Spring

(3) Adjusting screw

22) Tighten the adjusting screw to the specified torque, then loosen it.

Tightening torque:

25 N-m (2.5 kgf-m, 18.4 ft-lb)

23) Tighten the adjusting screw to the specified torque, then loosen it within 20°.

Tightening torque:

3.9 N-m (0.4 kgf-m, 2.9 ft-lb)

24) Adjust the adjustment screw until the rotational resistance of gearbox is within specifications. <Ref. to PS-35, TURNING RESISTANCE OF GEARBOX, INSPECTION, Steering Gearbox.>

25) Apply liquid gasket to lock nut and install it into adjusting screw. While holding the adjusting screw with wrench, tighten the lock nut using ST.

Liquid gasket:

THREE BOND 1141

ST 926230000 SPANNER

Tightening torque (lock nut):

25 N-m (2.5 kgf-m, 18.1 ft-lb)

NOTE:

Hold the adjusting screw with a wrench to prevent it from turning while tightening lock nut.

26) Remove the gearbox from ST.

ST1 926200000 STAND

ST2 34199AG000 BOSS D

Steering Gearbox

POWER ASSISTED SYSTEM (POWER STEERING)

Brought to you by Eris Studios
NOT FOR SALE

- 27) Install the four pipes on gearbox.
(1) Connect the pipes A and B to gearbox.

Tightening torque:

Refer to the component parts. <Ref. to PS-4, POWER ASSISTED SYSTEM, COMPONENT, General Description.>

- (2) Connect the pipes C and D to gearbox.

Tightening torque:

Pipe D: 37 N·m (3.8 kgf-m, 27.3 ft-lb)

Pipe C: 29 N·m (3.0 kgf-m, 21.4 ft-lb)

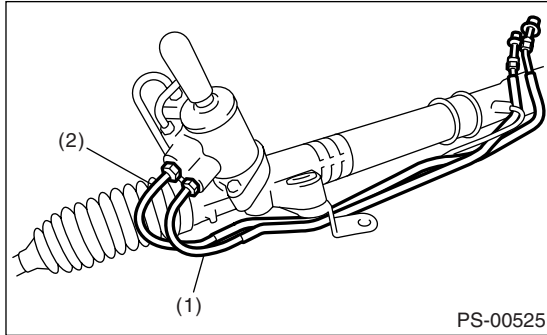

- (1) Pipe D
(2) Pipe C

Steering Gearbox

POWER ASSISTED SYSTEM (POWER STEERING)

Brought to you by Eris Studios
NOT FOR RESALE

E: INSPECTION

1. BASIC INSPECTION

1) Clean all the disassembled parts, and check for wear, damage or any other faults, then repair or replace as necessary.

2) When disassembling, check the inside of gearbox for water. If any water is found, carefully check the boot for damage, input shaft dust seal, adjusting screw and boot clips for poor sealing. If faulty, replace with new parts.

No.	Parts	Inspection	Corrective action
1	Input shaft	(1) Bent input shaft (2) Damage on serration	If the bend or damage is excessive, replace the entire gearbox.
2	Dust seal	(1) Crack or damage (2) Wear	If the outer wall slips, the lip is worn out or damage is found, replace it with a new part.
3	Rack & pinion	Poor mating of rack with pinion	(1) Adjust the backlash properly. By measuring the turning torque of the gearbox and sliding resistance of rack, check if the rack & pinion engage uniformly and smoothly with each other. (Refer to "Service limit".) (2) Pull out the entire rack to allow viewing of the teeth, and check for damage. When the abnormality is found in either (1) or (2), replace the entire gearbox.
4	Gearbox unit	(1) Bending of the rack shaft (2) Bending of the cylinder portion (3) Crack or damage on the cast iron portion	Replace the gearbox with a new part.
		(4) Wear or damage on rack bushing	If the free play of rack shaft in radial direction is out of the specified range, replace the gearbox with new part. (Refer to "Service limit".)
		(5) Wear on input shaft bearing	If the free play of input shaft in radial and axial direction is out of the specified range, replace the gearbox with a new part. (Refer to "Service limit".)
5	Boot	Crack, damage or deterioration	Replace.
6	Tie-rod	(1) Looseness of ball joint (2) Bend of tie-rod	Replace.
7	Tie-rod end	Damage or deterioration of dust seal	Replace.
8	Adjusting screw spring	Deterioration	Replace.
9	Boot clip	Deterioration	Replace.
10	Sleeve	Damage	Replace.
11	Pipe	(1) Damage to flared surface (2) Damage to flare nut (3) Damage to pipe	Replace.

Steering Gearbox

POWER ASSISTED SYSTEM (POWER STEERING)

Brought to you by Eris Studios
NOT FOR SALE

2. SERVICE LIMIT

Make a measurements as follows. If it exceeds the specified service limits, adjust or replace.

NOTE:

When making a measurement, vise the gearbox using ST. Never vise the gearbox by inserting aluminum plates etc. between vise and gearbox.

ST1 926200000 STAND
ST2 34199AG000 BOSS D

3. RACK SHAFT PLAY IN THE RADIAL DIRECTION

Right-turn steering:

Service limit

0.12 mm (0.005 in) or less

Condition

Weighting point

L1: 10 mm (0.39 in)

P: 98 N (10 kgf, 22 lb)

Measuring point

L2: 25 mm (0.98 in)

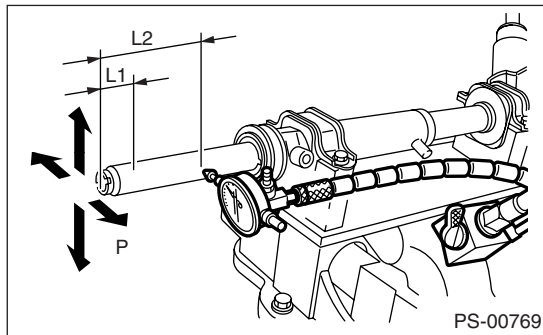

4. INPUT SHAFT PLAY

In radial direction:

Service limit

0.26 mm (0.01 in) or less

Condition

P: 98 N (10 kgf, 22 lb)

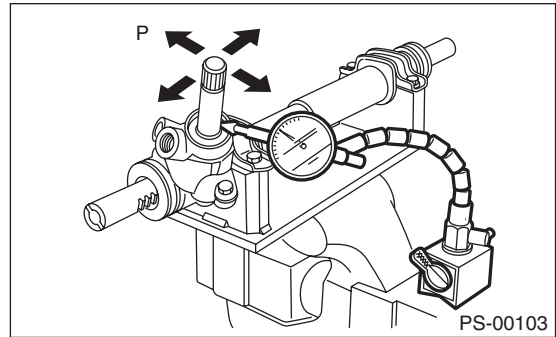

In axial direction:

Without play

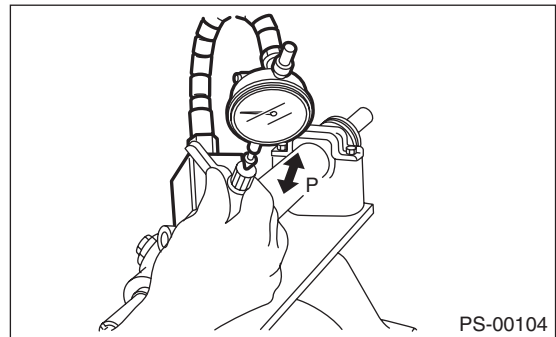

5. TURNING RESISTANCE OF GEARBOX

Using the ST, measure the gearbox turning resistance.

ST 34099PA100 SPANNER

Service limit:

Maximum allowable resistance:

11.3 N (1.15 kgf, 2.54 lb) or less

Difference between right and left turning resistance:

24% or less

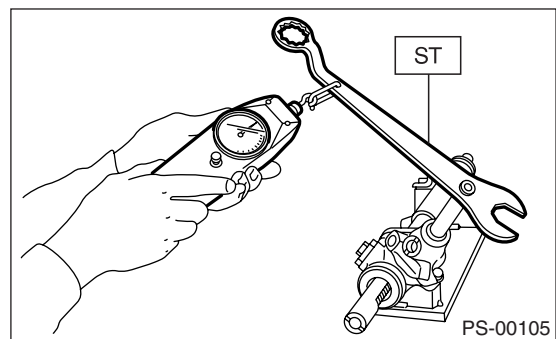

Steering Gearbox

POWER ASSISTED SYSTEM (POWER STEERING)

Brought to you by Eris Studios
NOT FOR RESALE

6. OIL LEAKAGE

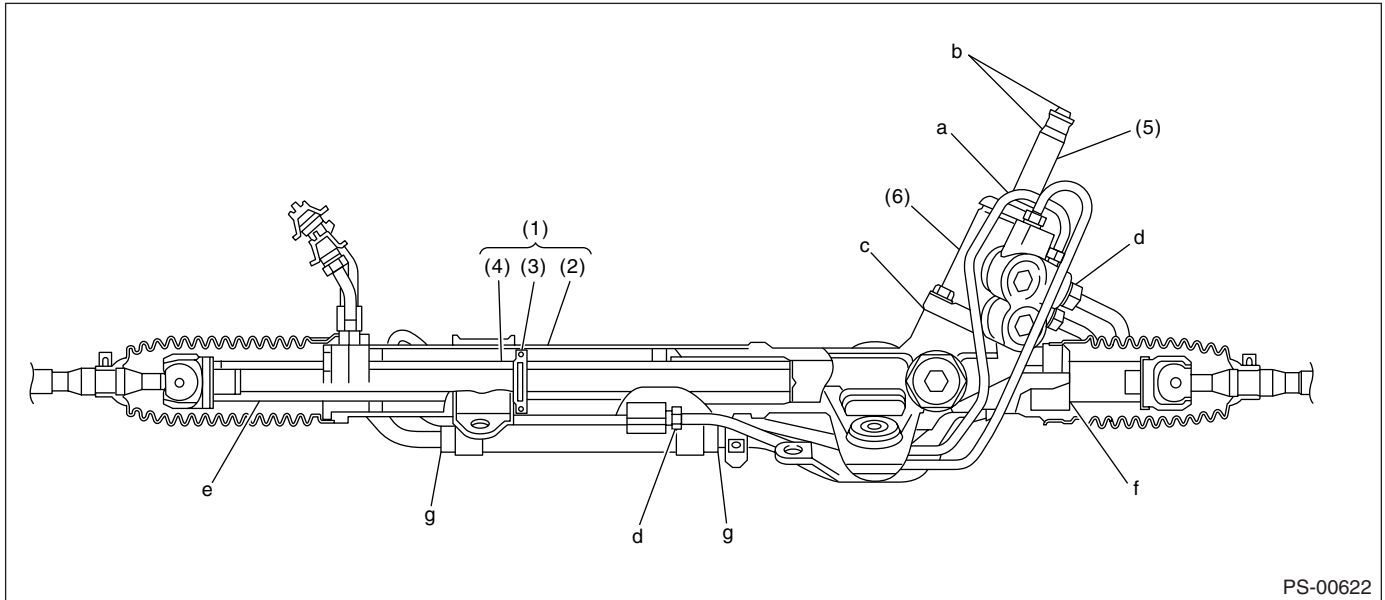

PS-00622

- (1) Power cylinder
- (2) Cylinder

- (3) Rack piston
- (4) Rack axle

- (5) Input shaft
- (6) Valve housing

Steering Gearbox

POWER ASSISTED SYSTEM (POWER STEERING)

Brought to you by Eris Studios
NOT FOR SALE

- 1) Lift up the vehicle.
- 2) If a fluid leak is found, clean the fluid completely from the suspect area, and turn the steering wheel 30 to 40 times to the left and right from lock to lock, with the engine running, and check again for leaks immediately, and also after a few hours have passed.
- 3) Cause and solution for oil leakage from "a"
The oil seal is damaged. Replace the valve assembly with a new part.
- 4) Cause and measure for oil leakage from "b"
The torsion bar O-ring is damaged. Replace the valve assembly with a new part.
- 5) Cause and measure for oil leakage from "c"
The oil seal is damaged. Replace the valve assembly or oil seal with a new part.
- 6) Cause and solution for oil leakage from "d"
The pipe is damaged. Replace the faulty pipe or O-ring.
- 7) Cause and solution for oil leakage from "g"
The hose is damaged. Replace the hose with a new part.
- 8) If leak is other than a, b, c, d or g, or if oil is leaking from gearbox, move the right and left boots toward tie-rod end side, respectively, with the gearbox mounted to the vehicle, and remove fluid from surrounding portions. Then, turn the steering wheel from lock to lock about 30 to 40 times with the engine running, and make comparison of the leaked portion immediately after and several hours after this operation.

(1) Leakage from "e"

The cylinder seal is damaged. Replace the rack bushing with a new part.

(2) Leakage from "f"

There are two possible causes. Perform the following step first. Remove the pipe assembly B from the valve housing, and close the circuit using ST.

ST 926420000 PLUG

Turn the steering wheel from lock to lock approx. 30 to 40 times with the engine running, then inspect the leaked portion immediately after and several hours after this operation.

- If leakage from "f" is noted again:

The oil seal of pinion and valve assembly is damaged. Replace the pinion & valve assembly with a new part. Or replace the oil seal and the parts that are damaged during disassembly with new parts.

- If oil stops leaking from "f":

The oil seal of rack housing is damaged. Replace the oil seal and parts that are damaged during disassembly with new parts.

F: ADJUSTMENT

- 1) Adjust the front toe.
<Ref. to FS-11, FRONT WHEEL TOE-IN, INSPECTION, Wheel Alignment.>

Standard of front toe:

IN 3 — OUT 3 mm (IN 0.12 — OUT 0.12 in)

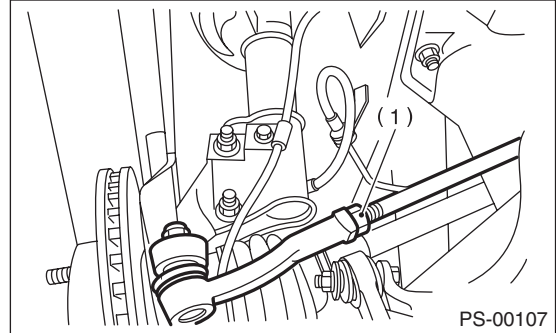

(1) Lock nut

- 2) Adjust the steering angle of the wheels.

Standard of steering angle:

Model	STI
Inner wheel	36.6°±1.5°
Outer wheel	32.2°±1.5°

- 3) If the steering wheel spokes are not horizontal when wheels are set in the straight ahead position, or error is more than 5° on the periphery of the steering wheel, correctly re-install the steering wheel.

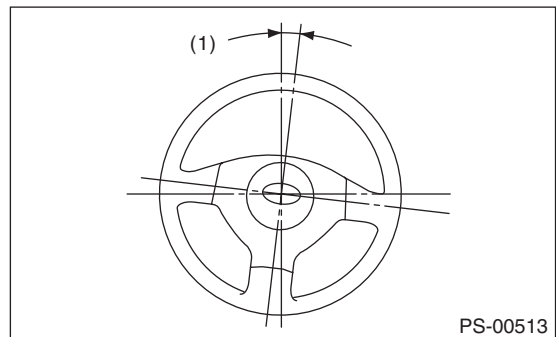

(1) 5° or less

- 4) If the steering wheel spokes are not horizontal with vehicle set in the straight ahead position after this adjustment, correct it by turning the right and left tie-rods in the opposite direction from each other by the same angle.

Pipe Assembly

POWER ASSISTED SYSTEM (POWER STEERING)

Brought to you by Eris Studios
NOT FOR RESALE

6. Pipe Assembly

A: REMOVAL

- 1) Disconnect the ground cable from the battery.
- 2) Lift up the vehicle, and remove the front cross-member support plate.

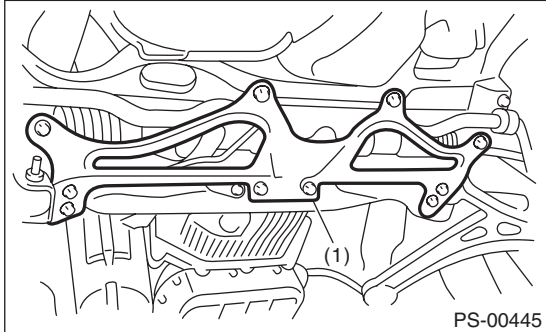

(1) Front crossmember support plate

- 3) Remove the one pipe joint at the center of the gearbox, and connect the vinyl hose to the pipe and the joint. Discharge the fluid by turning the steering wheel fully clockwise and counterclockwise. Discharge the fluid similarly from other pipes.

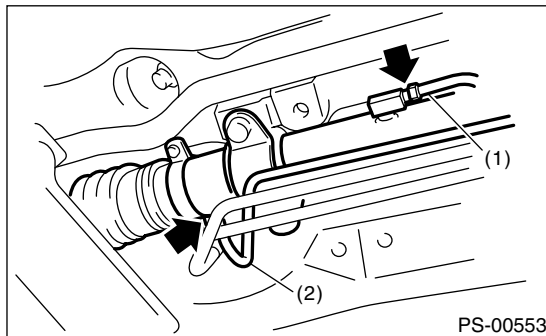

(1) Pipe A
(2) Pipe B

- 4) Remove the clamp E from return hose and pressure hose.

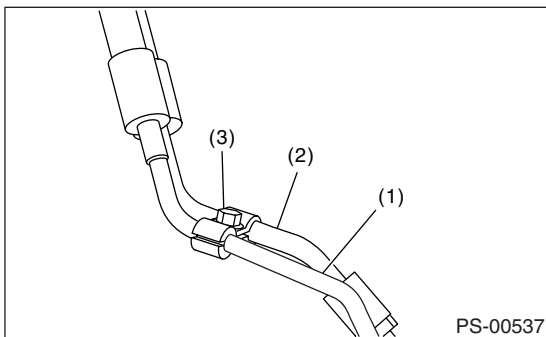

(1) Return hose
(2) Pressure hose
(3) Clamp E

- 5) Disconnect the pipe D from return hose and pipe C from pressure hose.

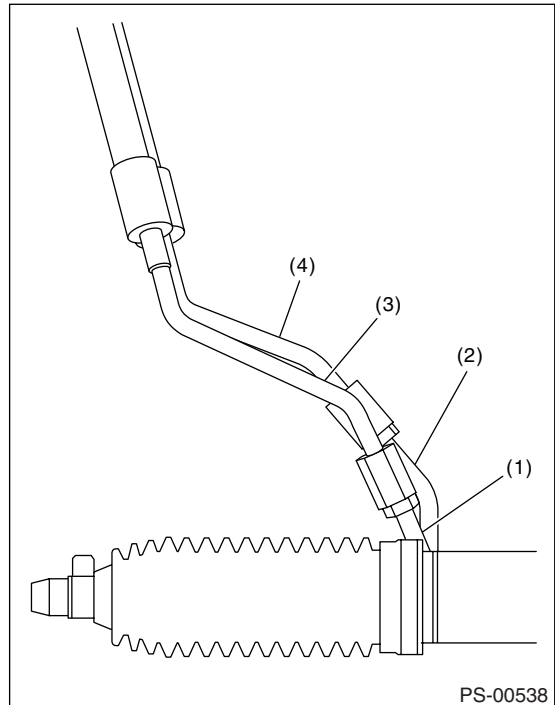

(1) Pipe C
(2) Pipe D
(3) Pressure hose
(4) Return hose

- 6) Remove the air intake duct.
- 7) Disconnect the suction hose and pressure hose from oil pump.

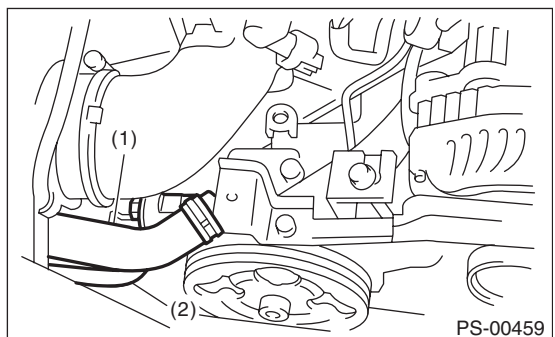

(1) Suction hose
(2) Pressure hose

Pipe Assembly

POWER ASSISTED SYSTEM (POWER STEERING)

Brought to you by Eris Studios
NOT FOR SALE

8) Disconnect the suction hose and return hose from the reservoir tank.

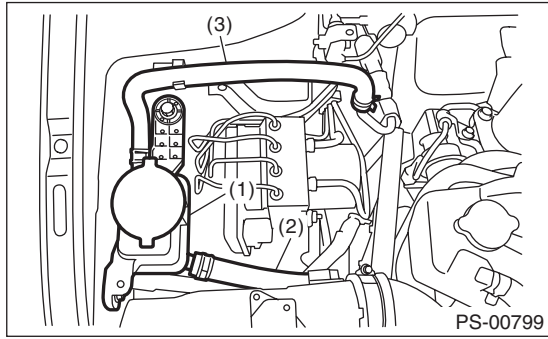

- (1) Reservoir tank
- (2) Suction hose
- (3) Return hose

9) Remove the hose bracket and take out the hose assembly from vehicle.

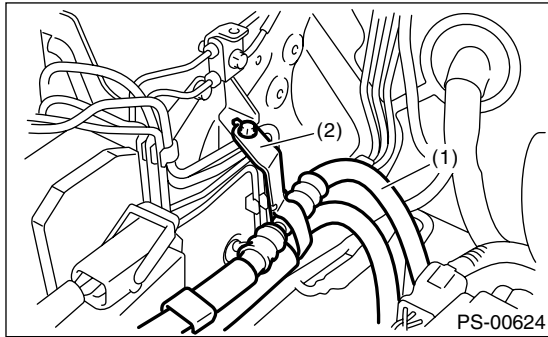

- (1) Hose ASSY
- (2) Hose bracket

B: INSTALLATION

1) Temporarily tighten the hose bracket bolt.

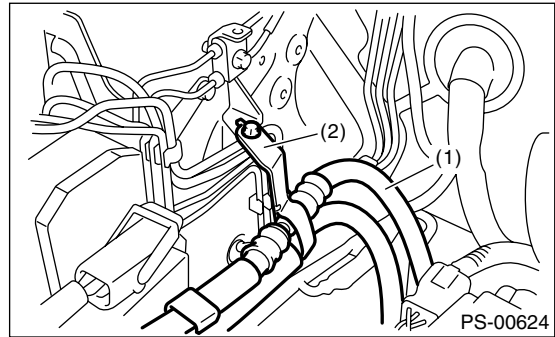

- (1) Hose ASSY
- (2) Hose bracket

2) Install the plastic clip to the pressure hose and suction hose.

CAUTION:

Align the installation position of the plastic clip with the protector edge of the suction hose.

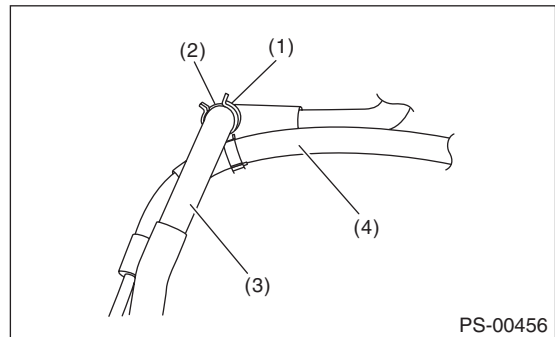

- (1) Plastic clip
- (2) Protector
- (3) Suction hose
- (4) Pressure hose

Pipe Assembly

Brought to you by Eris Studios
NOT FOR RESALE

POWER ASSISTED SYSTEM (POWER STEERING)

3) Connect the suction hose and return hose to the reservoir tank.

CAUTION:

Firmly insert the plastic clip of return hose to the bracket.

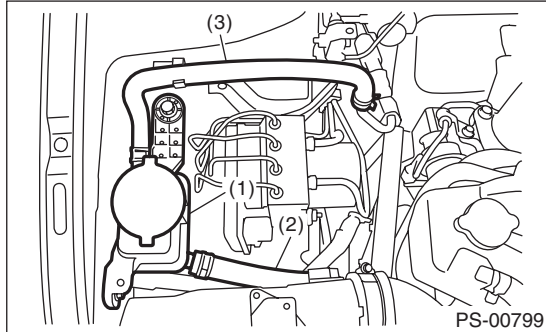

- (1) Reservoir tank
- (2) Suction hose
- (3) Return hose

4) Connect the suction hose and pressure hose to the oil pump. Tighten the eye bolt of pressure hose.

Tightening torque:

40 N·m (4.1 kgf·m, 29.5 ft·lb)

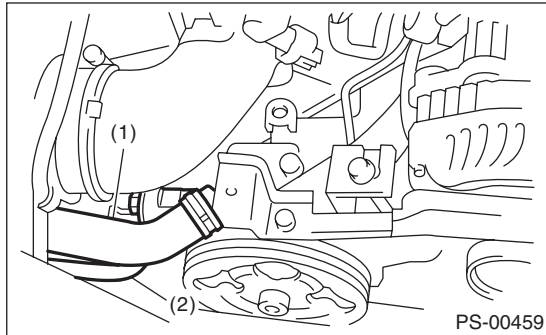

- (1) Suction hose
- (2) Pressure hose

5) Temporarily connect pressure hose and pipe C, and the return hose and pipe D. Temporarily tighten the bolt of clamp E.

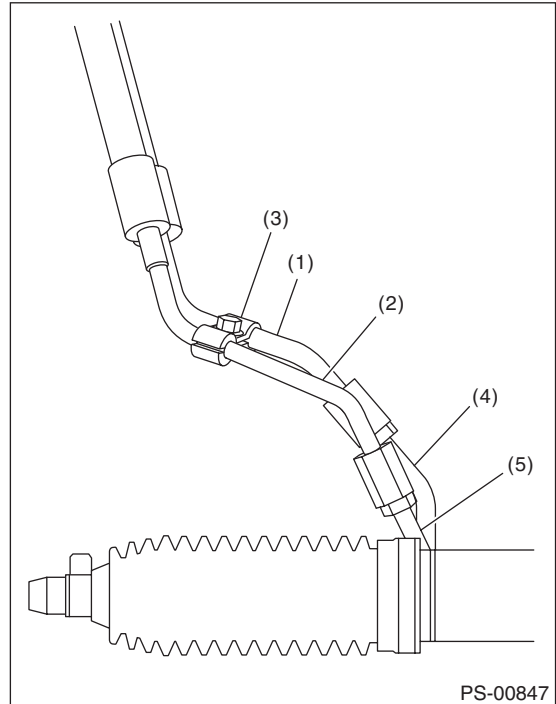

- (1) Return hose
- (2) Pressure hose
- (3) Clamp E
- (4) Pipe C
- (5) Pipe D

6) Tighten clamp E.

Tightening torque:

7.5 N·m (0.76 kgf·m, 5.53 ft·lb)

7) Tighten the pressure hose and pipe C, and the return hose and pipe D.

Tightening torque:

15 N·m (1.5 kgf·m, 10.8 ft·lb)

Brought to you by Eris Studios
NOT FOR SALE

8) Connect pipes A and B to the four pipe joints of the gearbox.

Tightening torque:

Refer to "COMPONENT" of "General Description". <Ref. to PS-4, POWER ASSISTED SYSTEM, COMPONENT, General Description.>

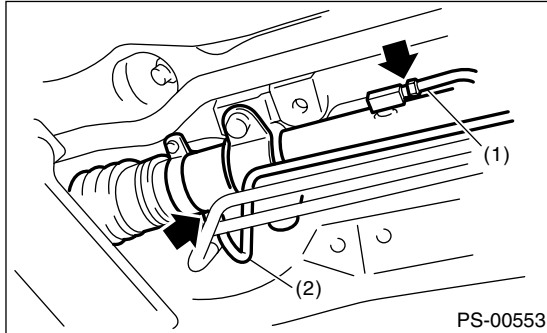

- (1) Pipe A
- (2) Pipe B

9) Install the front crossmember support plate and jack-up plate.

10) Lower the vehicle.

11) Tighten the bolts which hold the hose bracket.

Tightening torque:

10 N·m (1.02 kgf·m, 7.4 ft·lb)

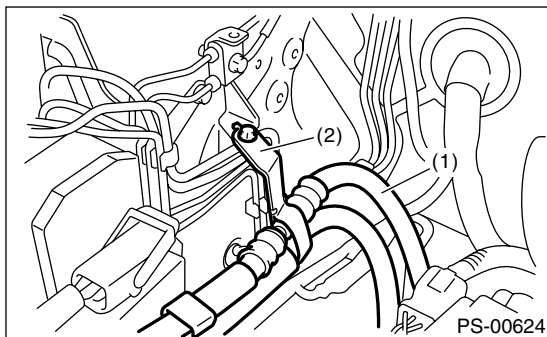

- (1) Hose ASSY
- (2) Hose bracket

12) Install the air intake duct.

13) Connect the ground cable to the battery.

14) Fill with the specified fluid.

CAUTION:

Never start the engine before filling with fluid; otherwise the vane pump may become seized.

15) Finally, check the clearance between pipes or hoses as shown in the figure in "General Diagnostic Table". <Ref. to PS-56, INSPECTION OF CLEARANCE, INSPECTION, General Diagnostic Table.>

Pipe Assembly

POWER ASSISTED SYSTEM (POWER STEERING)

Brought to you by Eris Studios
NOT FOR RESALE

C: INSPECTION

Check all disassembled parts for wear, damage or other problems. Repair or replace the defective parts as necessary.

Part	Maintenance parts	Corrective action
Pipe	<ul style="list-style-type: none"> • O-ring fitting surface damage • Nut damage • Pipe damage 	Replace with a new part.
Clamp	<ul style="list-style-type: none"> • Loose clamps 	Replace with a new part.
Hose	<ul style="list-style-type: none"> • Flare surface damage • Flare nut damage • Outer surface cracks • Outer surface wear • Clip damage • End coupling or adapter deformation 	Replace with a new part.

CAUTION:

Although the surface layer materials of rubber hoses have excellent weathering resistance, heat resistance and resistance for low temperature brittleness, they are likely to be damaged chemically by brake fluid, battery electrolyte, engine oil and automatic transmission fluid and their service lives are to be very shortened. Wipe off hoses immediately if any of these come into contact with the hoses. The durability of a hose gradually deteriorates over long periods of exposure to high or low temperatures, and the service life of the hose is shortened accordingly. Because of this, vehicles driven in high temperature regions, low temperature regions and under conditions where frequent steering operations are required over a short period of time, must be inspected frequently. Continuous discharge of the relief valve for 5 seconds or more will reduce the service lives of hoses, oil pump, fluid, etc., due to over heating.

Trouble	Possible cause	Corrective action
Pressure hose burst	Excessive holding time of relief status	Instruct customers.
	Malfunction of the relief valve	Replace the oil pump.
	Poor cold characteristic of fluid	Replace fluid.
Disconnection of the return hose	Improper connection	Repair.
	Loosening of the clip	Retighten.
	Poor cold characteristic of fluid	Replace fluid.
Fluid slightly leaking out of hose	Wrong layout, tensioned	Replace the hose.
	Excessive play of engine due to deterioration of engine mounting rubber	Replace the parts if defective.
	Improper stop position of pitching stopper	Replace the parts if defective.
Crack on hose	Excessive holding time of relief status	Replace. Instruct customers.
	Excessive tightening torque for return hose clip	Replace.
	Power steering fluid, engine oil, electrolyte adhere on the hose surface	Replace. Be careful during service work.
	Too many uses in extremely cold weather	Replace. Instruct customers.

NOTE:

There are conditions in which a fluid leak is diagnosed, but is not actually leaking. This is because the fluid spilt during the last maintenance was not completely wiped off. Be sure to wipe off spilt fluid thoroughly after maintenance.

Pipe Assembly

POWER ASSISTED SYSTEM (POWER STEERING)

Brought to you by Eris Studios
NOT FOR SALE

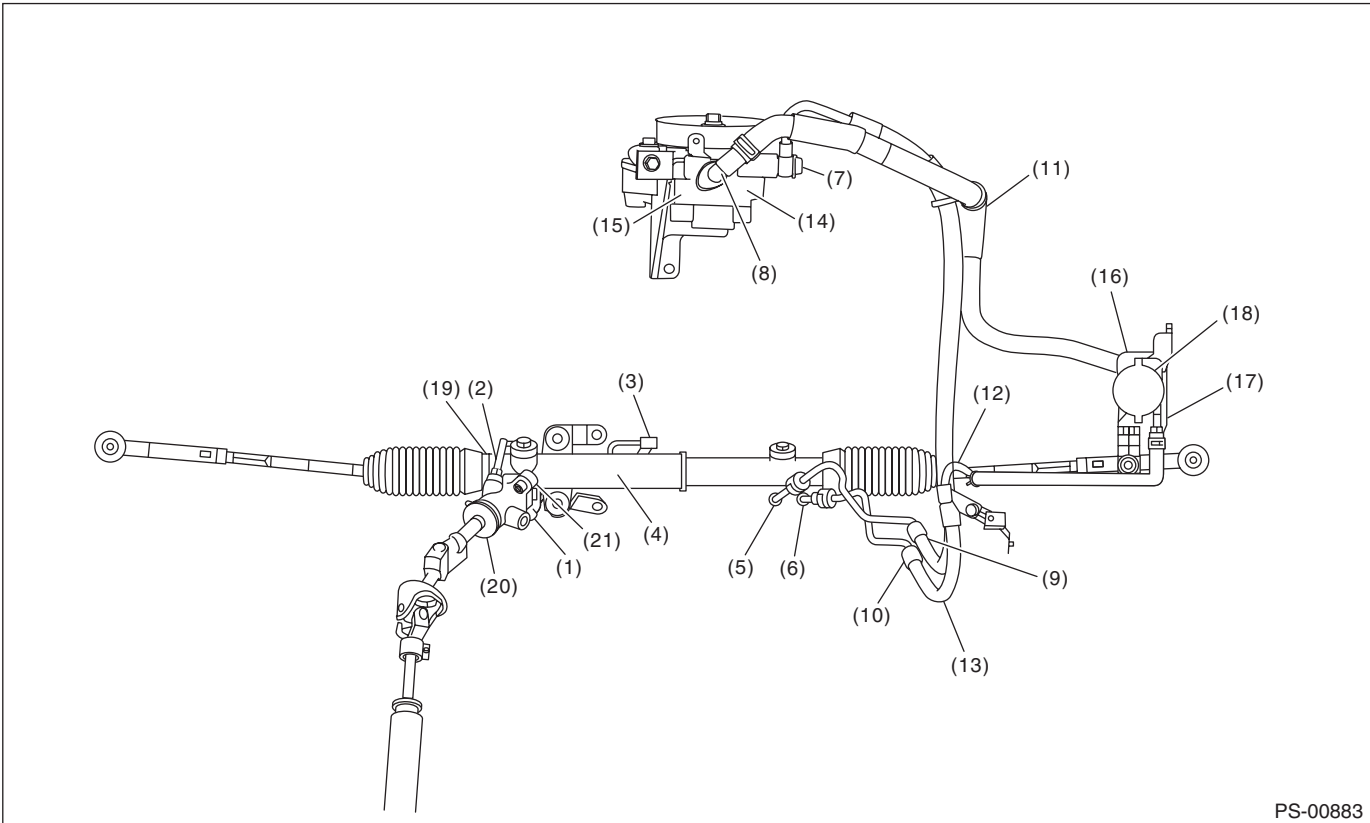

PS-00883

Fluid leaking area	Possible cause	Corrective action
Leakage from the connections of pipes and hoses, numbered (1) through (8) in the figure	Insufficient tightening of flare nut, adhesion of dirt, damage to flare or flare nut or eye bolt	Loosen and retighten. Replace if ineffective.
	Improper installation of hose or clamp	Retighten or replace the clamp.
	Damaged O-ring or gasket	Replace the O-ring, gasket pipe or hose with new part, if still no improvement, replace the gearbox as well.
Leakage from hose (9) through (13) in the figure	Crack or damage in hose	Replace with a new part.
	Crack or damage in hose hardware	Replace with a new part.
Leakage from surrounding of cast iron portion of oil pump, (14) and (15) in the figure	Damaged O-ring	Replace the oil pump.
	Damaged gasket	Replace the oil pump.
Leakage from oil tank, (16) and (17) in the figure	Crack in oil tank	Replace the oil tank.
Leakage from filler neck of (18)	Damaged cap gasket	Replace the cap.
	Crack in root of filler neck	Replace the oil tank.
	Fluid level too high	Adjust the fluid level.
Leakage from power cylinder of gearbox area (19) in the figure	Damaged oil seal	Replace the oil seal.
Leakage from (20), (21) in the figure and control valve of gearbox	Damaged gasket or oil seal	Replace the problem parts.
	Damage in control valve	Replace the control valve.

POWER ASSISTED SYSTEM (POWER STEERING)

7. Oil Pump

A: REMOVAL

- 1) Disconnect the ground cable from the battery.
- 2) Remove the air intake duct.
- 3) Remove the pulley belt cover.
- 4) Loosen the belt tension securing bolt and generator securing bolt, then remove the power steering pump V-belt.

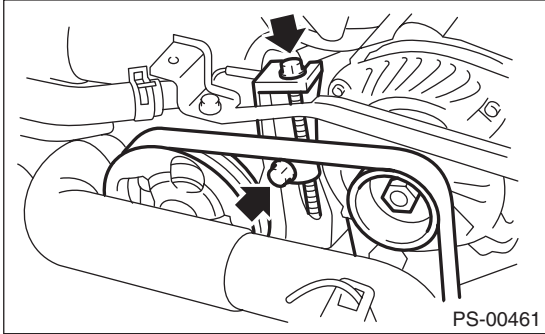

- 5) Disconnect the connector from power steering pump switch.
- 6) Disconnect the pressure hose and suction hose from the oil pump.

CAUTION:

- Do not allow fluid to come into contact with the pulley belt.
- To prevent foreign matter from entering the hose and pipe, cover the open ends with clean cloth.

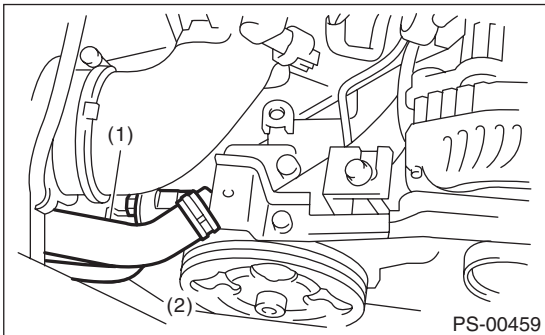

- (1) Suction hose
- (2) Pressure hose

- 7) Remove the installation bolt of the power steering pump bracket.

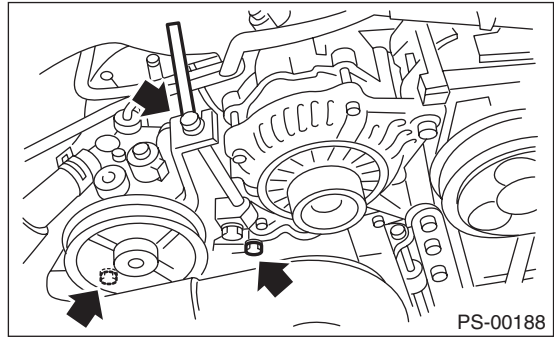

- 8) Place the oil pump bracket in a vise, and remove the two bolts from the front side of the oil pump.

CAUTION:

When securing the oil pump bracket in a vise, hold the oil pump bracket with the least possible force between two pieces of wood.

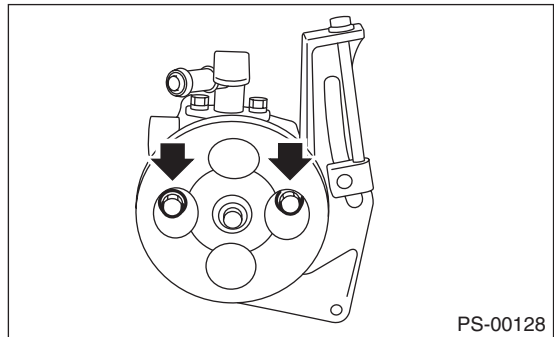

- 9) Remove the bolt from the rear side of oil pump.
- 10) Disassemble the oil pump and bracket by inserting a flat tip screwdriver as shown in the figure.

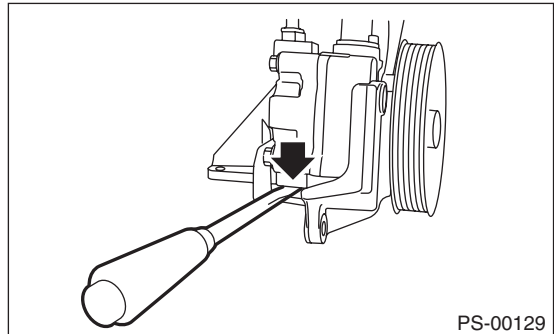

Oil Pump

POWER ASSISTED SYSTEM (POWER STEERING)

Brought to you by Eris Studios
NO RESALE

B: INSTALLATION

1) Install the oil pump to bracket.

Tightening torque:

16 N·m (1.6 kgf·m, 11.8 ft·lb)

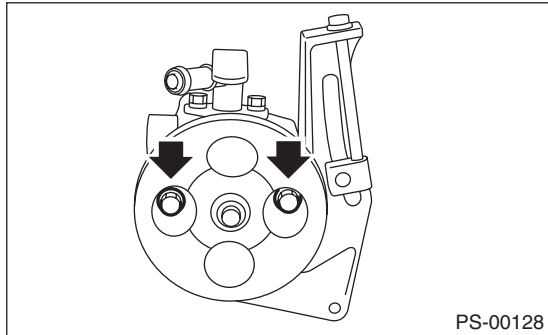

Tightening torque:

48 N·m (4.9 kgf·m, 35.4 ft·lb)

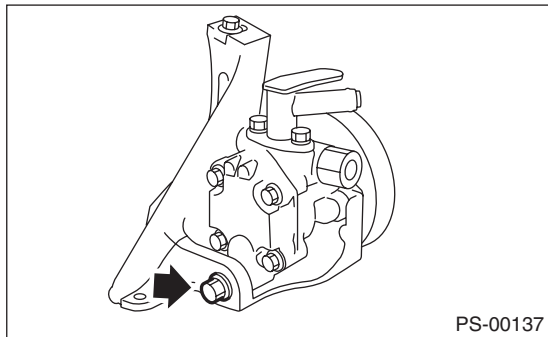

2) Attach the installation bolts of the power steering pump bracket.

Tightening torque:

<Ref. to PS-6, OIL PUMP, COMPONENT, General Description.>

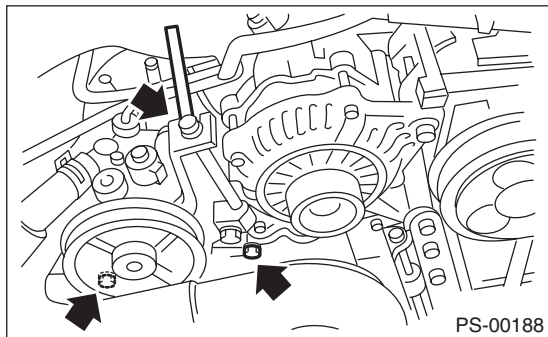

3) After installing the oil pump, fill the oil pump with fluid while rotating the pulley by hand and bleed the air from the oil pump.

CAUTION:

Always fill the oil pump with the fluid to prevent abnormal noise and seizure of the oil pump.

4) Connect the pressure hose and suction hose.

Tightening torque:

Eye bolt

40 N·m (4.1 kgf·m, 29.5 ft·lb)

CAUTION:

Be careful when installing; If the hose is twisted it may come into contact with other parts.

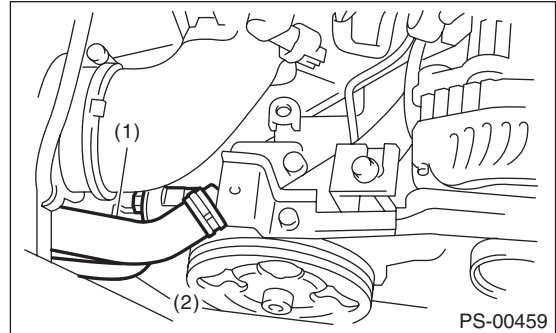

(1) Suction hose

(2) Pressure hose

5) Connect the power steering pump switch to the connector.

6) Install the V-belts to the oil pump.

7) Check the tension of the V-belt.

<Ref. to ME(STI)-44, INSPECTION, V-belt.>

8) Tighten the belt tension bolt.

Tightening torque:

25 N·m (2.5 kgf·m, 18.4 ft·lb)

9) Install the pulley belt cover.

10) Install the air intake duct.

11) Connect the ground cable to the battery.

12) Fill with the specified power steering fluid.

<Ref. to PS-51, Power Steering Fluid.>

CAUTION:

Never start the engine before filling with fluid; otherwise the vane pump may become seized.

Oil Pump

POWER ASSISTED SYSTEM (POWER STEERING)

Brought to you by Eris Studios
NOT FOR RESALE

C: INSPECTION

1. BASIC INSPECTION

Perform the following inspection procedures and replace faulty parts.

No.	Parts	Inspection	Corrective action
1	Oil pump (Exterior)	(1) Crack, damage or oil leakage	Replace the oil pump with a new part.
		(2) Play of pulley shaft	Measure the radial play and axial play. If any of these exceeds the service limit, replace the oil pump with a new part.
2	Pulley	(1) Damage	Replace with a new part.
		(2) Bend	Measure the V groove deflection. If it exceeds the service limit, replace the pulley with a new part.
3	Oil pump (Interior)	(1) Faulty or seized of vane pump	Check the rotating resistance of pulley. If it exceeds the service limit, replace the oil pump with a new part.
		(2) Bend in the shaft or damage to bearing	If the a string is wrapped on the pulley and rotated, and the oil pump emits a noise that is markedly different in tone and loudness from a sound of a new oil pump, replace the oil pump with a new part.
4	O-ring	Cracking or deterioration	Replace with a new part.
5	Bracket	Crack	Replace with a new part.

Oil Pump

POWER ASSISTED SYSTEM (POWER STEERING)

Brought to you by Eris Studios
NOT FOR SALE

2. SERVICE LIMIT

Make a measurements as follows. If it exceeds the service limit, replace with a new part.

CAUTION:

- When securing the oil pump on a vise, hold the oil pump with the least possible force between two pieces of wood.
- Do not grip the exterior of the flow control valve or pulley on a vise; as this can deform the exterior of the valve or pulley. Select properly sized wood pieces.

1) Play of the pulley shaft

Condition:

P: When applying the force of 9.8 N (1.0 kgf, 2.2 lbf)

Service limit:

Play in the radial direction (Direction $\leftarrow \rightarrow$)
0.4 mm (0.016 in) or less

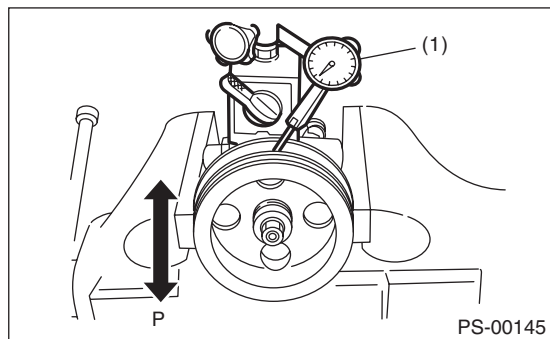

(1) Dial gauge

Axial play (Direction $\leftarrow \rightarrow$)
0.9 mm (0.035 in) or less

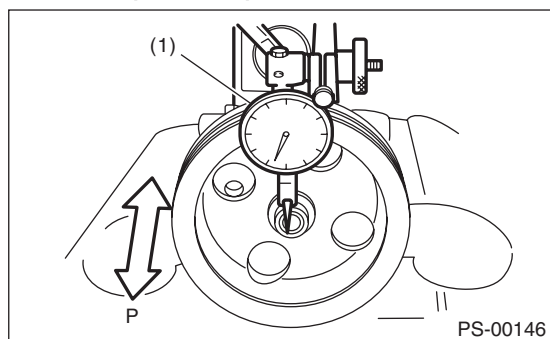

(1) Dial gauge

2) Deflection of the pulley groove

Service limit:

1.0 mm (0.039 in) or less

NOTE:

Read the value for one surface of V ditch, and then the value for another off the dial gauge.

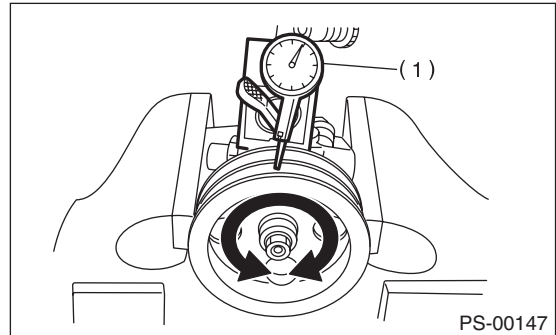

(1) Dial gauge

3) Rotating resistance of pulley

Service limit:

Maximum load: 9.22 N (0.94 kgf, 2.07 lbf) or less

NOTE:

- A rather higher value may be indicated when pulley starts turning.
- Measure the load during rotation to make a judgment.

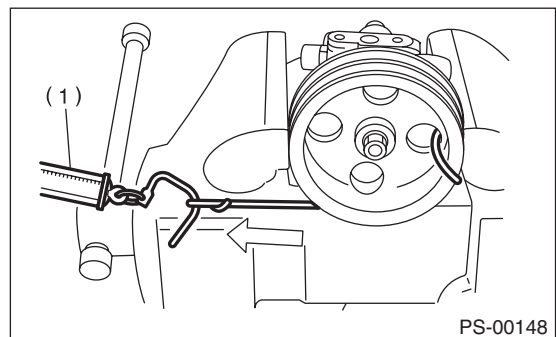

(1) Spring scale

Oil Pump

POWER ASSISTED SYSTEM (POWER STEERING)

Brought to you by Eris Studios
NOT FOR RESALE

3. HYDRAULIC PRESSURE

NOTE:

- To measure hydraulic pressure correctly, be sure to complete all the items in "INSPECTION", prior to performing the measurement. <Ref. to PS-52, INSPECTION, General Diagnostic Table.>
- Do not leave the valve of pressure gauge closed or hold the steering wheel at lock for 5 seconds or more in any case, this can damage the oil pump.
- Before attaching a pressure gauge, place cloth at locations where fluid is expected to spill. Wipe off any spilt fluid completely after the measurement.

1) Regular pressure measurement

- (1) Connect the ST1, ST2 and ST3.

ST1 925711000 PRESSURE GAUGE
ST2 34099AC020 ADAPTER HOSE B
ST3 34099AC010 ADAPTER HOSE A

- (2) Remove the air intake duct.
(3) Disconnect the pipe C from pump.
(4) Using the gasket (Part No. 34621AC021) and bolt (Part No. 34620AC010), install the ST2 to pump instead of pressure hose.

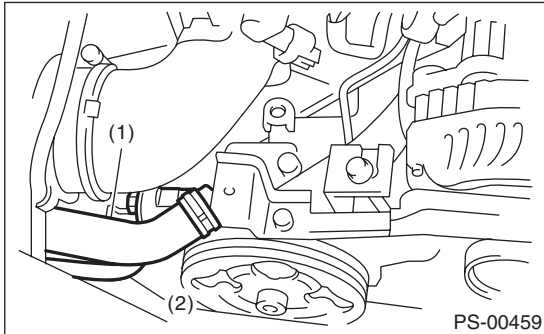

- (1) Suction hose
(2) Pressure hose

- (5) Attach the ST3 to the end of pressure hose which is removed from pump.
(6) Replenish power steering fluid up to the specified level.
(7) Open the valve, and start the engine.

- (8) Measure the regular pressure.

ST1 925711000 PRESSURE GAUGE
ST2 34099AC020 ADAPTER HOSE B
ST3 34099AC010 ADAPTER HOSE A

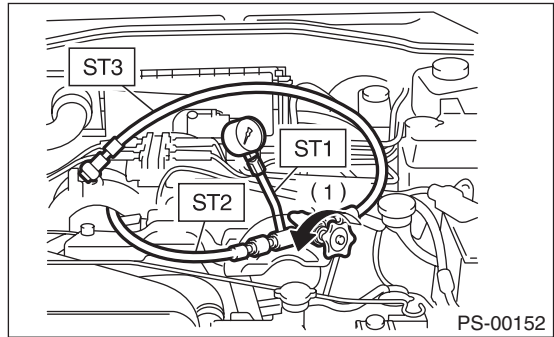

- (1) Valve

Service limit:

981 kPa (10 kgf/cm², 142 psi) or less

- (9) If it is not within the specification, replace the problem part for the following problems. (Pipe or hose clogged, leaks from fluid line, and mixture of foreign matter in fluid line)

2) Measure the relief pressure.

- (1) Using the STs, measure the relief pressure.
(2) Close the valve.
(3) Measure the relief pressure.

ST1 925711000 PRESSURE GAUGE
ST2 34099AC020 ADAPTER HOSE B
ST3 34099AC010 ADAPTER HOSE A

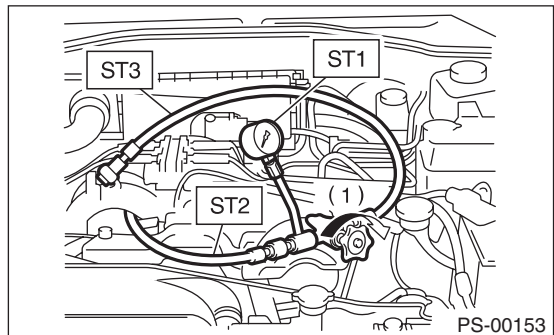

- (1) Valve

Service limit:

**8,300 — 9,000 kPa
(85 — 92 kgf/cm², 1,203 — 1,305 psi)**

- (4) If it is not within the specification, replace the oil pump.

Brought to you by Eris Studios
NOT FOR SALE

- 3) Measure the working pressure.
 - (1) Using the ST, measure the working pressure.
 - (2) Open the valve.
 - (3) Measure the working pressure of control valve by turning steering wheel from stop to stop.

ST1 925711000 PRESSURE GAUGE
ST2 34099AC020 ADAPTER HOSE B
ST3 34099AC010 ADAPTER HOSE A

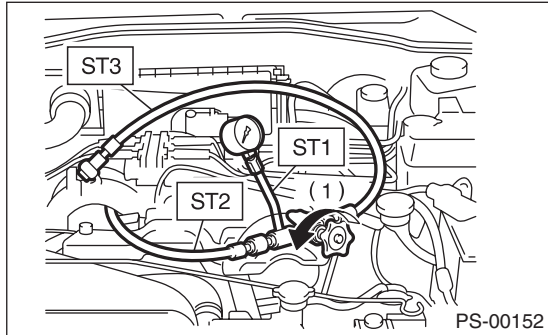

(1) Valve

Service limit:

8,300 — 9,000 kPa

(85 — 92 kgf/cm², 1,203 — 1,305 psi)

- (4) If it is out of specification, measure the steering effort. <Ref. to PS-55, MEASUREMENT OF STEERING EFFORT, INSPECTION, General Diagnostic Table.> If it is not within specification, replace the control valve itself or control valve and pinion as a single unit, using new parts.

Reservoir Tank

POWER ASSISTED SYSTEM (POWER STEERING)

Brought to you by Eris Studios
NOT FOR RESALE

8. Reservoir Tank

A: REMOVAL

- 1) Drain fluid from the reservoir tank.
- 2) Disconnect the hose from reservoir tank.

CAUTION:

To prevent foreign matter from entering the hose and pipe, cover the open ends of them with clean cloth.

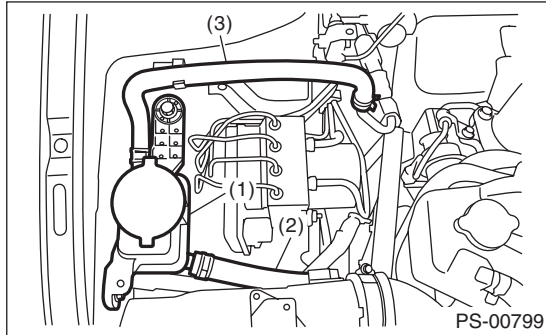

- (1) Reservoir tank
- (2) Suction hose
- (3) Return hose

- 3) Remove the reservoir tank from the body.

B: INSTALLATION

- 1) Install the reservoir tank to the body.

Tightening torque:

13 N·m (1.32 kgf·m, 9.6 ft·lb)

- 2) Connect the hose to the reservoir tank.

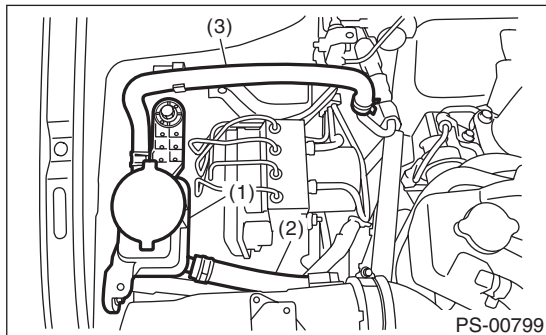

- (1) Reservoir tank
- (2) Suction hose
- (3) Return hose

- 3) Replenish power steering fluid up to the specified level. <Ref. to PS-51, INSPECTION, Power Steering Fluid.>

C: INSPECTION

Check the reservoir tank for cracks, breakage or damage. If a failure is found, replace the reservoir tank.

Power Steering Fluid

POWER ASSISTED SYSTEM (POWER STEERING)

Brought to you by Eris Studios
NOT FOR SALE

9. Power Steering Fluid

A: SPECIFICATION

Recommended power steering fluid
SUBARU ATF or DEXRON III

B: INSPECTION

1) Check the power steering fluid for deterioration or contamination. If the fluid is highly deteriorated or contaminated, drain it and refill with new fluid.

2) Check the joints and units for oil leakage. If any oil leaks are found, repair or replace the applicable part.

3) Inspect the fluid level of reservoir tank with vehicle on level surface and engine stopped.

If the level is at "MIN." point or below, add fluid to keep the level in the specified range of the indicator. If at "MAX". point or above, drain fluid by using a syringe or the like.

(1) Check at power steering fluid temperature 20°C (68°F); read the fluid level on the "COLD" side.

(2) Check at power steering fluid temperature 80°C (176°F); read the fluid level on the "HOT" side.

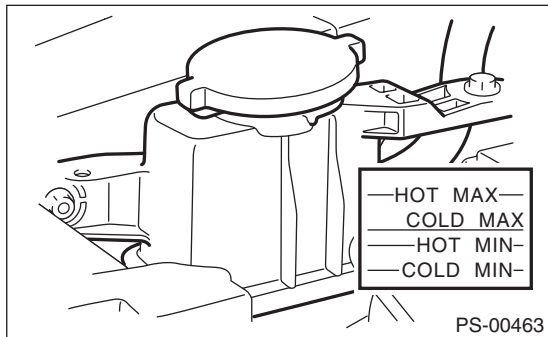

C: REPLACEMENT

1) Lift up the vehicle.
2) Remove the crossmember support.
3) Remove the pipe joint in the center of gearbox, and connect the vinyl hose to the pipe and joint. Wipe fluid off while turning the steering wheel.

4) Add the specified fluid to reservoir tank at "MAX" level.

5) Maintaining the fluid level of step 4), continue to turn the steering wheel slowly from lock to lock until the bubbles stop appearing on oil surface.

6) If the steering wheel is turned in a low fluid level condition, air will be sucked into the pipe. If air has entered, leave it for about half an hour and then repeat step 5) again.

7) Start the engine and let it idle.

8) Continue to turn the steering wheel slowly from lock to lock again until the bubbles stop appearing on oil surface, while keeping the fluid at the level in step 4).

Normally bubbles will stop appearing after turning the steering wheel from lock to lock three times.

9) In case bubbles do not stop appearing in the tank, leave it for about half an hour and then repeat step 4) again.

10) Lower the vehicle, and then idle the engine.

11) Continue to turn the steering wheel from lock to lock until the bubbles stop appearing and change of the fluid level is within 3 mm (0.12 in).

12) In case the following happens, leave it about half an hour and then do step 8) to 11) again.

(1) The fluid level changes 3 mm (0.12 in) or more.

(2) Bubbles remain on the upper surface of the fluid.

(3) Grinding noise is generated from oil pump.

13) Check the fluid leakage after turning steering wheel from lock to lock with engine running.

General Diagnostic Table

POWER ASSISTED SYSTEM (POWER STEERING)

Brought to you by Eris Studios
NOT FOR RESALE

10. General Diagnostic Table

A: INSPECTION

Trouble	Possible cause	Corrective action
<ul style="list-style-type: none"> Steering effort is heavy in all ranges. Steering effort is heavy at stand still. Steering wheel vibrates when turning. 	1. Pulley belt <ul style="list-style-type: none"> Unequal length of pulley belts Contact with oil or grease Looseness or damage of the pulley belt Poor uniformity of the pulley belt cross section Pulley belt touches to pulley bottom Poor revolution of pulleys (except oil pump pulley) Poor revolution of oil pump pulley 	Adjust or replace.
	2. Tire and wheel <ul style="list-style-type: none"> Improper tire out of specifications^{*1} Improper wheel out of specifications^{*1} Tires not properly inflated 	Replace or reinflate.
	3. Fluid <ul style="list-style-type: none"> Low fluid level Air entry in fluid Dust entry in fluid Fluid deterioration Inadequate warm-up of fluid^{*2} 	Refill, bleed air, replace or instruct customer.
	4. Idle speed <ul style="list-style-type: none"> Lower idle speed Excessive drop of idle speed at start or when turning the steering wheel^{*3} 	Adjust or instruct customer.
	5. Measure the hydraulic pressure. <Ref. to PS-46, INSPECTION, Oil Pump.>	Replace the problem parts.
	6. Measure the steering wheel effort. <Ref. to PS-55, MEASUREMENT OF STEERING EFFORT, INSPECTION, General Diagnostic Table.>	Adjust or replace.
<ul style="list-style-type: none"> Vehicle leads to one side or the other. Returning force of steering wheel to center is poor. Steering wheel vibrates when turning. 	1. Fluid line <ul style="list-style-type: none"> Folded hose Flattened pipe 	Correct or replace.
	2. Tire and wheel <ul style="list-style-type: none"> Flat tire Mixed use of different tires Mixed use of different wheels Abnormal wear of tire Unequal tread remaining Unequal pressure of tire 	Adjust, fix or replace.
	3. Front alignment <ul style="list-style-type: none"> Improper or unequal caster Improper or unequal toe-in Loose suspension connections 	Adjust or retighten.
	4. Others <ul style="list-style-type: none"> Damaged joint assembly Unbalanced height Unbalanced weight 	Replace, adjust or instruct customer.
	5. Measure the steering wheel effort. <Ref. to PS-55, MEASUREMENT OF STEERING EFFORT, INSPECTION, General Diagnostic Table.>	Adjust or replace.

^{*1} If the tires or wheels are wider than standard, the load to power steering system is increased. Accordingly, in a condition, for example before fluid warms-up, relief valve may work before reaching maximum turning angle. In this case, steering effort may be heavy. When the measured hydraulic pressure is normal, there is no abnormal thing.

^{*2} In cold weather, steering effort may be heavy due to increased flow resistance of cold fluid. After warming-up engine, turn the steering wheel from stop to stop several times to warm-up fluid. If steering effort reduces normally, function is normal.

^{*3} In cold weather or with insufficient warm-up of the engine, steering effort may be heavy due to excessive drop of idling when turning the steering wheel. In this case, start the vehicle with increasing engine speed than usual. If steering effort reduces normally, function is normal.

General Diagnostic Table

POWER ASSISTED SYSTEM (POWER STEERING)

Brought to you by Eris Studios
NOT FOR SALE

1. NOISE AND VIBRATION

CAUTION:

Do not keep the relief valve operated for 5 seconds or more at any time or inner parts of the oil pump may be damaged due to rapid increase of fluid temperature.

NOTE:

- A screeching noise may be heard immediately after the engine start in extremely cold conditions. In this case, if the noise goes off during warm-up there is no abnormal function in the system. This is due to the fluid characteristics in extremely cold condition.
- The oil pump normally makes a small whining noise due to its mechanism. Even if a noise is heard when steering wheel is turned at stand still, there is no abnormal function in the system provided that the noise eliminates when the vehicle is driving.
- When turning the steering wheel with the brake applied when the vehicle is parked, a screeching noise may be generated by the brake disc and pads. This is not a fault in the steering system.
- There may be a small vibration around the steering devices when turning the steering wheel at standstill, even though the component parts are operating properly.

Hydraulic systems are likely to generate this kind of vibration as well as working noise and fluid noise because of combined conditions, i.e., road surface and tire surface, engine speed and turning speed of steering wheel, fluid temperature and braking condition.

These conditions do not indicate a problem in the system.

Confirm vibration by applying the parking brake on a concrete surface and turning the steering wheel from slowly to rapidly, in steps.

Trouble	Possible cause	Corrective action
Hiss noise (continuous) While engine is running.	Relief valve emits operating sound when steering wheel is completely turned in either direction. (Do not keep this condition for 5 seconds or more.)	Normal
	Relief valve emits operating sound when steering wheel is not turned. This means that the relief valve is defective.	Replace the oil pump.
Rattling noise (intermittent) While engine is running.	Interference with adjacent parts	Check the clearance. Correct if necessary. <Ref. to PS-56, INSPECTION OF CLEARANCE, INSPECTION, General Diagnostic Table.>
	Loosened installation of oil pump, oil tank, pump bracket, gearbox or crossmember	Retighten.
	Loose oil pump pulley or other pulley(s)	Retighten.
	Looseness of linkage, play of steering, improper tightening (looseness) of suspension joint or steering column	Retighten or replace.
	Sound generates from the inside of gearbox or oil pump.	Replace faulty parts in the gearbox or oil pump.
Knocking When turning steering wheel in both directions with small angle repeatedly at engine ON or OFF.	Excessive backlash Loosened lock nut for adjusting backlash	Adjust and retighten.
	Insufficient tightening or play in the tie-rod or tie-rod end	Retighten or replace.
Grinding noise (continuous) While engine is running.	Air in vane pump	Inspect and retighten the fluid line connection. Refill the fluid and vent air.
	Vane pump seizing	Replace the oil pump.
	Oil pump pulley bearing seized	Replace the oil pump.
	Folded hose, flattened pipe	Replace.
Squeal, squeak (intermittent or continuous) While engine is running.	Improper adjustment of pulley belt Damaged or over tensioned pulley belt Unequal length of pulley belts	Adjust or replace.
	Warpage or dirty V-groove surface of oil pump pulley	Clean or replace.

General Diagnostic Table

POWER ASSISTED SYSTEM (POWER STEERING)

Brought to you by Eris Studios
NOT FOR RESALE

Trouble	Possible cause	Corrective action
Sizzling noise (continuous) While engine is running.	Fluid aeration	Fix the faulty part causing aeration. Replace the fluid and vent air.
	Damaged pipe of gearbox	Replace the pipe.
	Faulty inside of hose or pipe Flattened hose or pipe	Repair or replace.
	Abnormal inside of oil tank	Replace.
	Removed oil tank cap	Install cap.
Whistle (continuous) While engine is running.	Faulty pipe of gearbox or faulty hose	Replace the faulty parts of the gearbox or the hose.
Whine or growl (intermittent or continuous) While engine is running with/ without steering turned.	Looseness of oil pump, oil pump bracket attachment	Retighten.
	Fault inside of oil pump or hose	Replace the oil pump or hose, if the noise can be heard when vehicle is running as well as being stopped.
	Air conditioner compression whirling noise	Remove the power steering pulley belt and check.
Grinding noise (continuous) While engine is running with the steering turned.	Fault inside of gearbox	Replace the faulty parts of gearbox.
	Faulty steering shaft bearing	Apply grease or replace.
	Occurs when turning the steering wheel with brakes (service or parking) applied.	If the noise goes off when brake is released, it is normal.
Vibration While engine is running with/ without steering turned.	Engine speed is too low.	Adjust, and notify customer.
	Air in vane pump	Repair faulty part Vent air.
	Damaged valve in oil pump or gearbox	Replace the faulty parts in gearbox and oil pump.
	Excessive play in steering, looseness of suspension parts	Retighten.

General Diagnostic Table

POWER ASSISTED SYSTEM (POWER STEERING)

Brought to you by Eris Studios
NO RESALE

2. MEASUREMENT OF STEERING EFFORT

	Step	Check	Yes	No
1	CHECK STEERING EFFORT. 1) Stop the vehicle on paved road. 2) Start the engine. 3) Idle the engine. 4) Install a spring scale on the steering wheel. 5) Pull the spring scale at a right angle to the steering wheel, and measure both right and left steering wheel efforts. NOTE: When turning the steering more quickly than necessary from a direction to the other direction at an engine speed of 2,000 rpm or more, steering effort may be heavy. This is caused by flow characteristic of the fluid in the oil pump and is not a defect.	Is the steering effort less than 29.4 N (3.0 kgf, 6.6 lbf)?	Go to step 2.	Adjust the backlash.
2	CHECK STEERING EFFORT. 1) Stop the engine. 2) Pull the spring scale at a right angle to the steering wheel, and measure both right and left steering wheel efforts.	Is the steering effort less than 294.2 N (30 kgf, 66.2 lbf)?	Go to step 3.	Perform the adjustment.
3	CHECK STEERING WHEEL EFFORT. 1) Remove the universal joint. 2) Measure the steering wheel effort.	Is the steering effort less than 2.26 N (0.23 kgf, 0.51 lbf)?	Go to step 4.	Check, adjust and replace if necessary.
4	CHECK STEERING WHEEL EFFORT. Measure the steering wheel effort.	Is the difference of steering effort between right and left less than 20%?	Go to step 5.	Check, adjust and replace if necessary.
5	CHECK UNIVERSAL JOINT. Measure the swing torque of the joint (yoke of steering column side). <Ref. to PS-14, INSPECTION, Universal Joint.>	Is the swing torque of the universal joint less than 7.3 N (0.74 kgf, 1.64 lbf)?	Go to step 6.	Replace with a new part.
6	CHECK UNIVERSAL JOINT. Measure the swing torque of the joint (yoke of gearbox side). <Ref. to PS-14, INSPECTION, Universal Joint.>	Is the swing torque of the universal joint less than 3.8 N (0.39 kgf, 0.86 lbf)?	Go to step 7.	Replace with a new part.
7	CHECK FRONT WHEEL. Check the front wheels.	Does the front wheels have unsteady revolution or rattling, or does the brake drag?	Inspect, readjust and replace if necessary.	Go to step 8.
8	CHECK TIE-ROD ENDS. Remove the tie-rod ends.	If the tie-rod ends of suspension have unsteady revolution or rattling?	Inspect and replace if necessary.	Go to step 9.
9	BALL JOINT CHECK. Remove the ball joint.	If the ball joints of suspension have unsteady revolution or rattling?	Inspect and replace if necessary.	Go to step 10.
10	CHECK GEARBOX. Measure the rotating of gearbox. <Ref. to PS-35, TURNING RESISTANCE OF GEARBOX, INSPECTION, Steering Gearbox.>	Is the rotating resistance of steering gearbox less than 11.3 N (1.15 kgf, 2.54 lbf)? Is the difference between clockwise and counterclockwise less than 24 %?	Steering effort is normal.	Readjust the backlash, and if ineffective, replace the faulty parts.

General Diagnostic Table

Brought to you by Eris Studios
NOT FOR RESALE

POWER ASSISTED SYSTEM (POWER STEERING)

3. INSPECTION OF CLEARANCE

This table lists various clearances that must be correctly adjusted to ensure the normal vehicle driving without interfering noise, or any other faults.

Install locations	Minimum allowance mm (in)
(1) Crossmember to Hose ASSY	3 (0.12)
(2) Front exhaust pipe to Hose ASSY	15 (0.59)
(3) Front frame side to Hose ASSY	10 (0.39)
(4) Turbo cover to Hose ASSY	10 (0.39)
(5) Master cylinder to Return hose	10 (0.39)
(6) Master cylinder to Hose clip	10 (0.39)
(7) VDC H/U to Hose ASSY	5 (0.20)
(8) Air cleaner to Hose ASSY	5 (0.20)
(9) Air boot to Hose ASSY	10 (0.39)
(10) Air cleaner hose to Hose ASSY	10 (0.39)
(11) Blow-by hose to Hose ASSY	8 (0.31)
(12) Over flow hose to Hose ASSY	8 (0.31)
(13) Brake pipe to Return hose	10 (0.39)
(14) Front suspension bracket to Return hose	5 (0.20)
(15) Front wheel apron to Return hose	5 (0.20)
(16) VDC H/U bracket to Suction hose	5 (0.20)
(17) Air cleaner case to Suction hose	5 (0.20)
(18) Air intake duct to Suction hose	10 (0.39)
(19) Air duct to Suction hose	10 (0.39)
(20) Front wheel apron to Reservoir tank	5 (0.20)
(21) VDC H/U to Reservoir tank	5 (0.20)

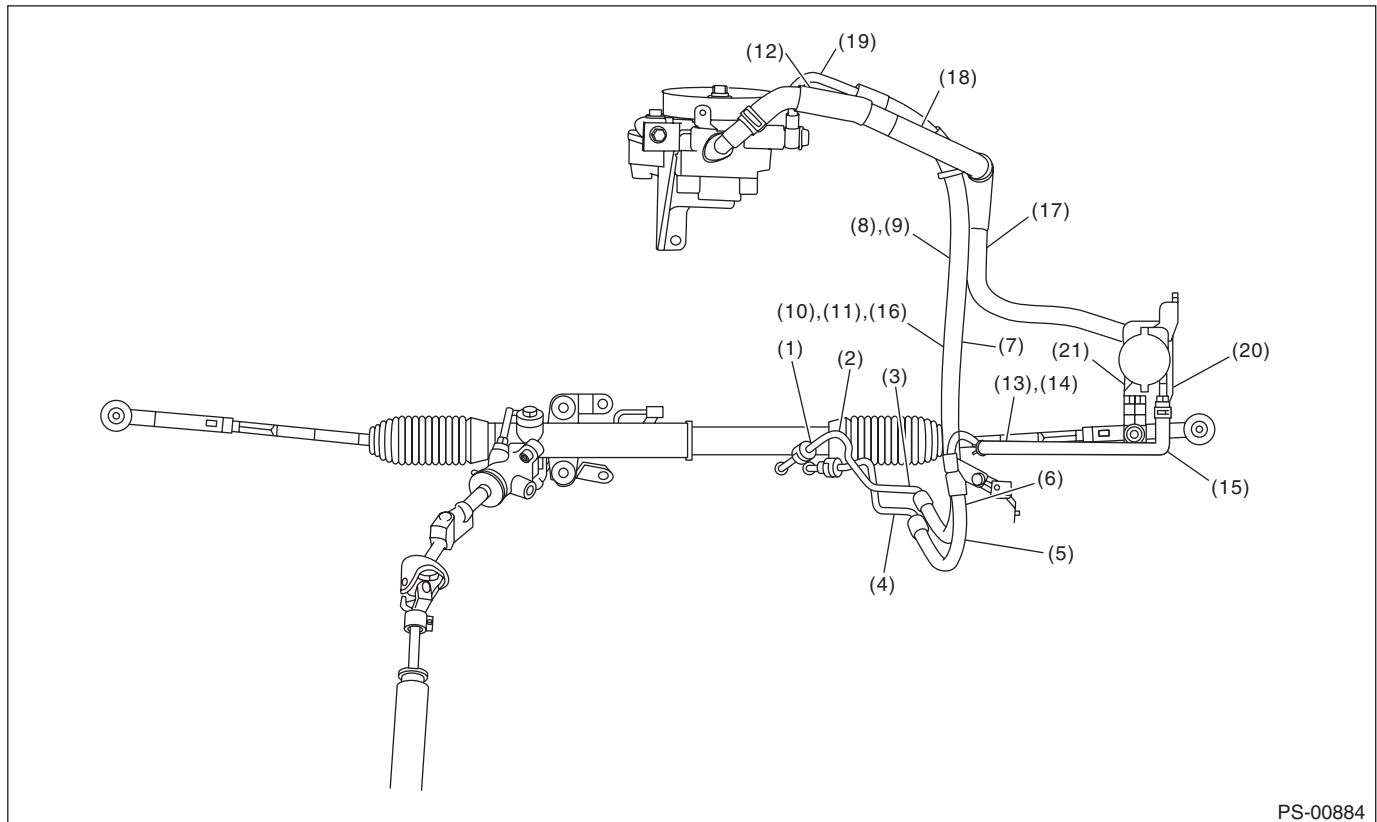

PS-00884