

Brought to you by Eris Studios
NOT FOR RESALE

MANUAL TRANSMISSION AND DIFFERENTIAL 6-SPEED (6MT)

General Description

MANUAL TRANSMISSION AND DIFFERENTIAL

Brought to you by Eris Studios
NOT FOR RESALE

1. General Description

A: SPECIFICATION

1. MANUAL TRANSMISSION AND FRONT DIFFERENTIAL

Type		6-forward speeds and 1-reverse	
Transmission gear ratio		1st	3.636
		2nd	2.235
		3rd	1.521
		4th	1.137
		5th	0.971
		6th	0.756
		Reverse	3.545
Front reduction gear	Final	Type of gear	Hypoid
		Gear ratio	3.900
Rear reduction gear	Transfer	Type of gear	Helical
		Gear ratio	1.103
	Final	Type of gear	Hypoid
		Gear ratio	3.545
Front differential	Type and number of gear		Planetary gear (pinion gear: 8, gear: 2)
	LSD type		Helical
Center differential	Type and number of gear		Planetary gear (Internal gear: 1, pinion gear: 6, sun gear: 1, and solenoid compression variable control multiplate clutch)
Transmission gear oil		GL-5	
Transmission gear oil capacity		4.1 ℓ (4.3 US qt, 3.6 Imp qt)	

2. TRANSMISSION GEAR OIL

Recommended oil:

GL-5 (75W-90) or equivalent

General Description

MANUAL TRANSMISSION AND DIFFERENTIAL

Brought to you by
NOVA Engineering Studios
NOT FOR SALE

B: COMPONENT

1. CLUTCH HOUSING

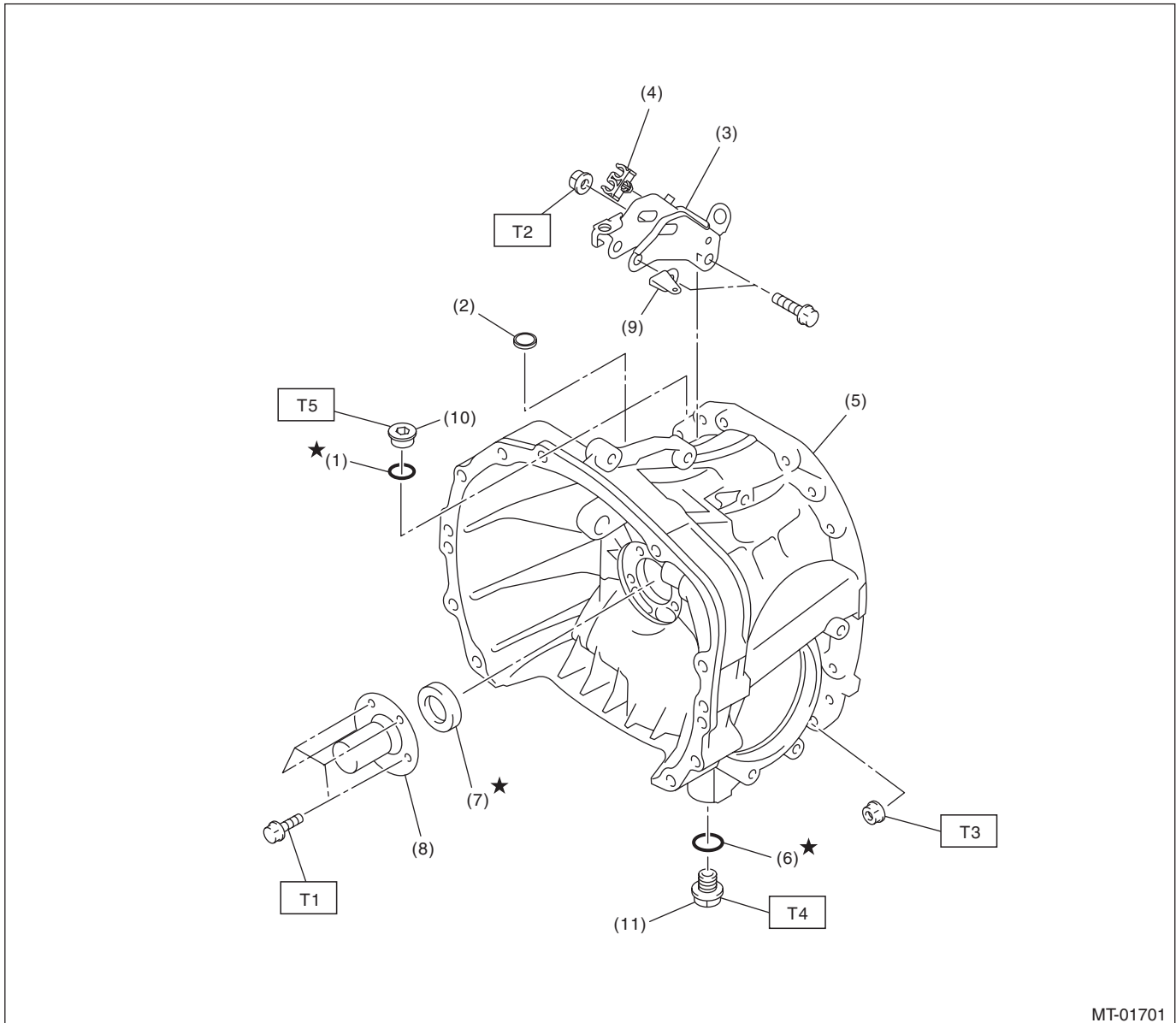

- | | |
|------------------------------|----------------------------------|
| (1) Gasket | (7) Oil seal |
| (2) Plug | (8) Clutch release bearing guide |
| (3) Pitching stopper bracket | (9) Return spring bracket |
| (4) Clip | (10) Plug |
| (5) Clutch housing | (11) Drain plug |
| (6) Gasket | |

Tightening torque: N·m (kgf·m, ft·lb)

T1: 6.4 (0.7, 4.7)

T2: 41 (4.2, 30.2)

T3: 50 (5.1, 36.9)

T4: 70 (7.1, 51.6)

T5: 46 (4.7, 33.9)

General Description

MANUAL TRANSMISSION AND DIFFERENTIAL

Brought to you by Eris Studios
NOT FOR RESALE

2. ADAPTER PLATE

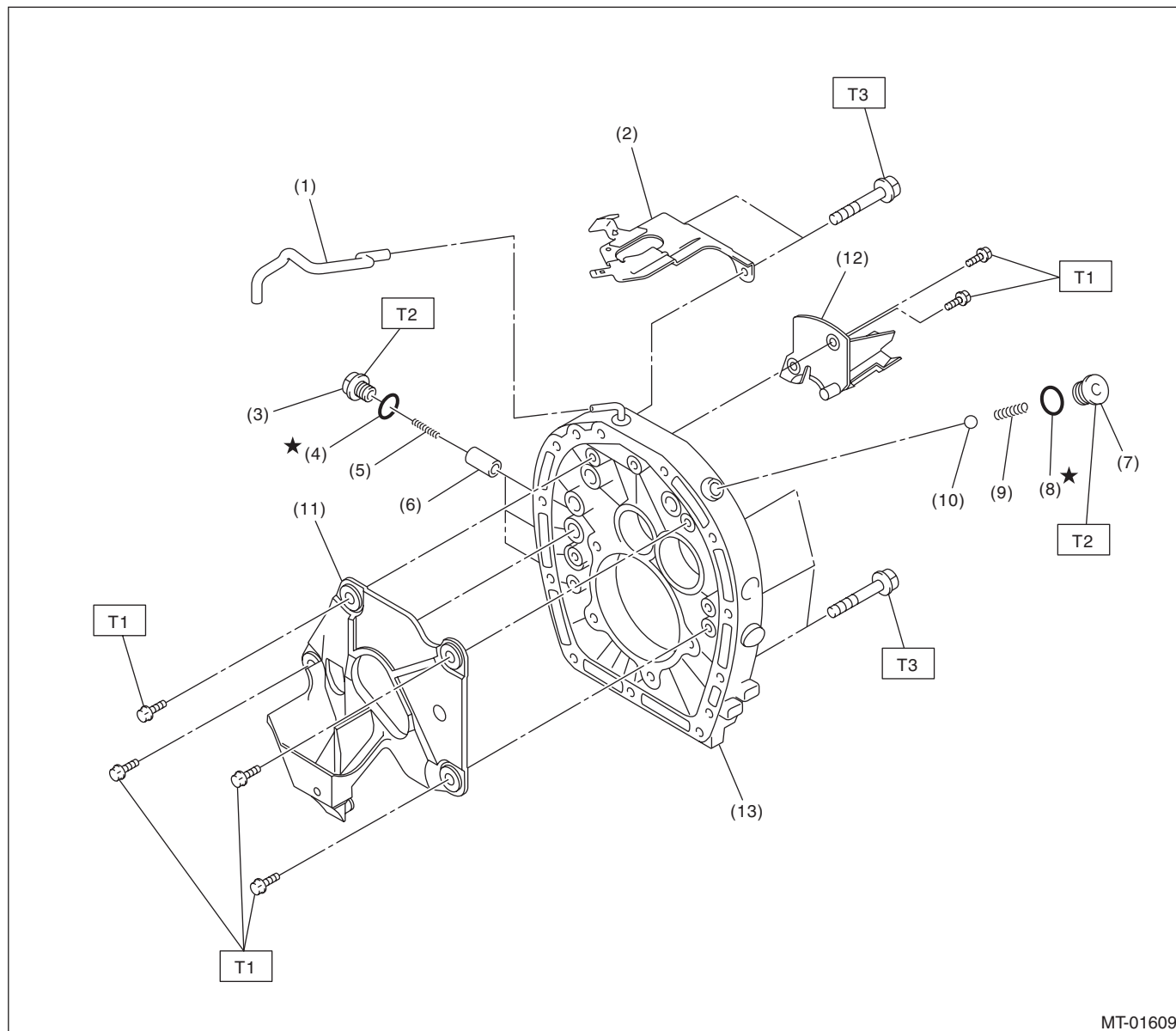

MT-01609

- (1) Breather hose
- (2) Transmission harness stay
- (3) Check plug
- (4) O-ring
- (5) Checking spring
- (6) Plunger

- (7) Check plug
- (8) O-ring
- (9) Checking spring
- (10) Check ball
- (11) Oil guide A
- (12) Oil guide B

- (13) Adapter plate

Tightening torque: N-m (kgf-m, ft-lb)

T1: 18 (1.8, 13.3)

T2: 37 (3.8, 27.3)

T3: 50 (5.1, 36.9)

General Description

MANUAL TRANSMISSION AND DIFFERENTIAL

Brought to you by
NOVA
SALE
Meris Studios

3. TRANSMISSION CASE

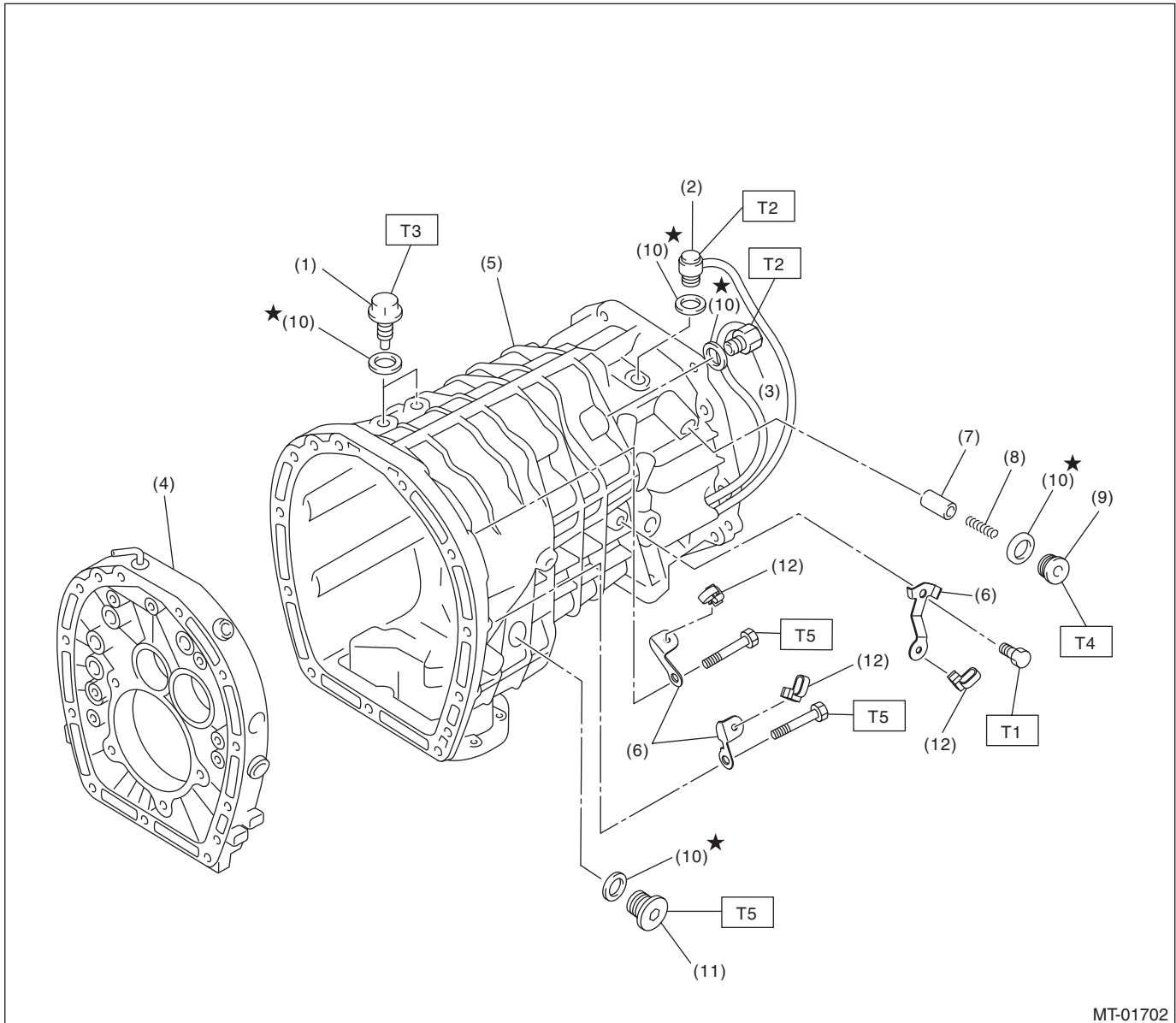

MT-01702

- | | |
|-----------------------------|------------------|
| (1) Pilot bolt | (7) Plunger |
| (2) Neutral position switch | (8) Spring |
| (3) Back-up light switch | (9) Plug |
| (4) Adapter plate | (10) Gasket |
| (5) Transmission case | (11) Filler plug |
| (6) Harness bracket | (12) Band clip |

Tightening torque: N·m (kgf·m, ft·lb)

T1: 16 (1.6, 11.8)

T2: 32 (3.3, 23.6)

T3: 34 (3.5, 25.1)

T4: 41 (4.2, 30.2)

T5: 50 (5.1, 36.9)

General Description

MANUAL TRANSMISSION AND DIFFERENTIAL

Brought to you by Eris Studios
NOT FOR RESALE

4. OIL PAN AND OIL GUIDE

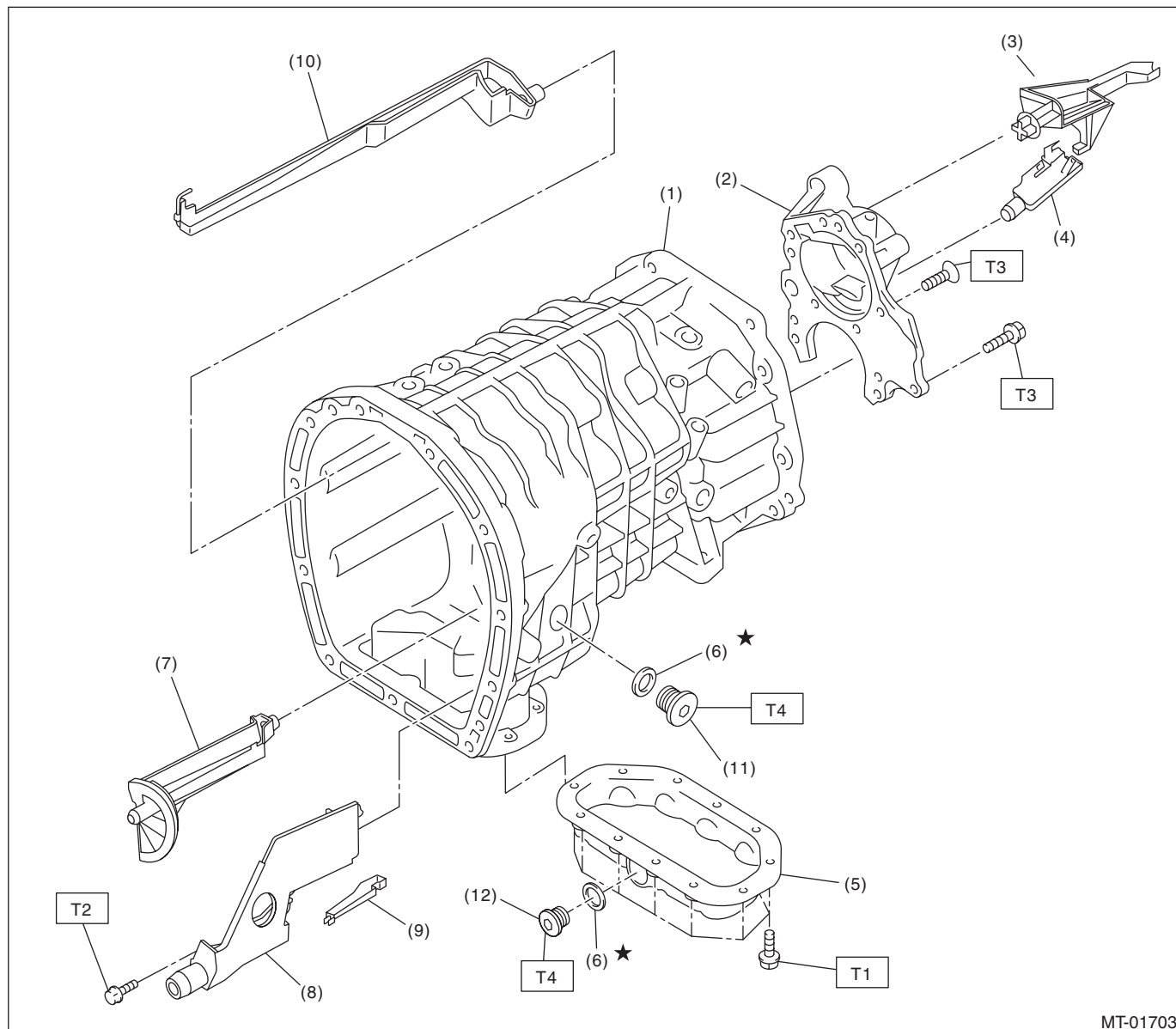

MT-01703

- | | |
|-----------------------------|------------------|
| (1) Transmission case | (7) Oil guide F |
| (2) Transfer bearing holder | (8) Oil guide D |
| (3) Oil guide G | (9) Oil guide E |
| (4) Oil guide H | (10) Oil guide C |
| (5) Oil pan | (11) Filler plug |
| (6) Gasket | (12) Drain plug |

Tightening torque: N·m (kgf·m, ft·lb)

T1: 6.4 (0.7, 4.7)

T2: 18 (1.8, 13.3)

T3: 25 (2.5, 18.4)

T4: 50 (5.1, 36.9)

General Description

MANUAL TRANSMISSION AND DIFFERENTIAL

Brought to you by
NOVA Studios
NOT FOR SALE

5. EXTENSION CASE AND CENTER DIFFERENTIAL

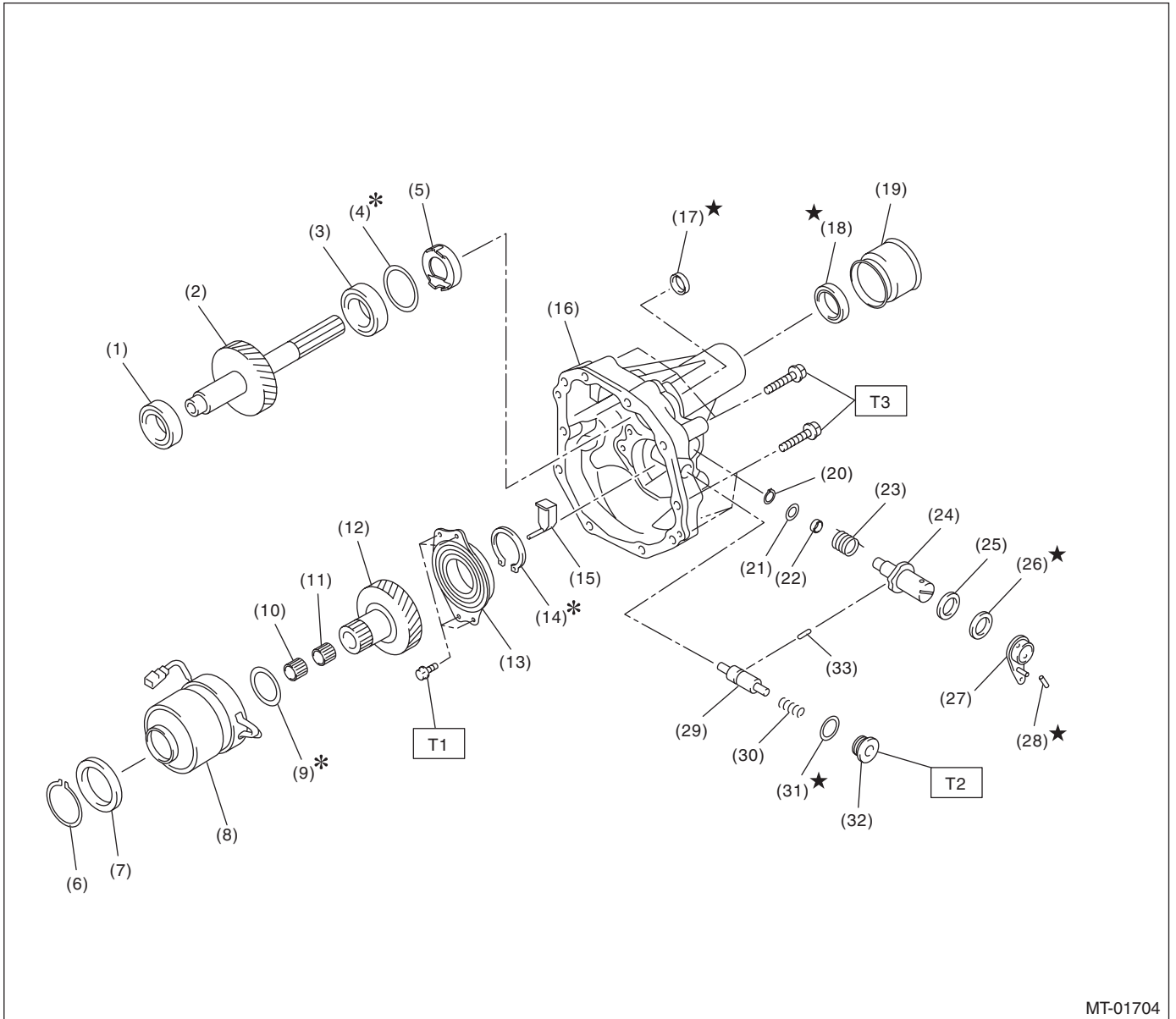

MT-01704

- | | | |
|---------------------------------|--------------------------|--------------------------------|
| (1) Taper roller bearing | (14) Snap ring | (27) Reverse check lever COMPL |
| (2) Transfer driven gear | (15) Oil guide | (28) Straight pin |
| (3) Taper roller bearing | (16) Extension case | (29) Reverse check plug |
| (4) Shim | (17) Oil seal | (30) Spring |
| (5) Oil plate | (18) Oil seal | (31) Gasket |
| (6) Snap ring | (19) Dust cover | (32) Plug |
| (7) Collar | (20) Snap ring | (33) Plunger |
| (8) Center differential | (21) Washer | |
| (9) Shim | (22) Bushing | |
| (10) Needle bearing | (23) Spring | |
| (11) Needle bearing | (24) Reverse check shaft | |
| (12) Transfer drive gear | (25) Ball bearing | |
| (13) Ball bearing (with flange) | (26) Oil seal | |

Tightening torque: N·m (kgf·m, ft·lb)
T1: 25 (2.5, 18.4)
T2: 41 (4.2, 30.2)
T3: 48 (4.9, 35.4)

General Description

MANUAL TRANSMISSION AND DIFFERENTIAL

Brought to you by Eris Studios
NOT FOR RESALE

6. SHIFTER FORK AND FORK ROD

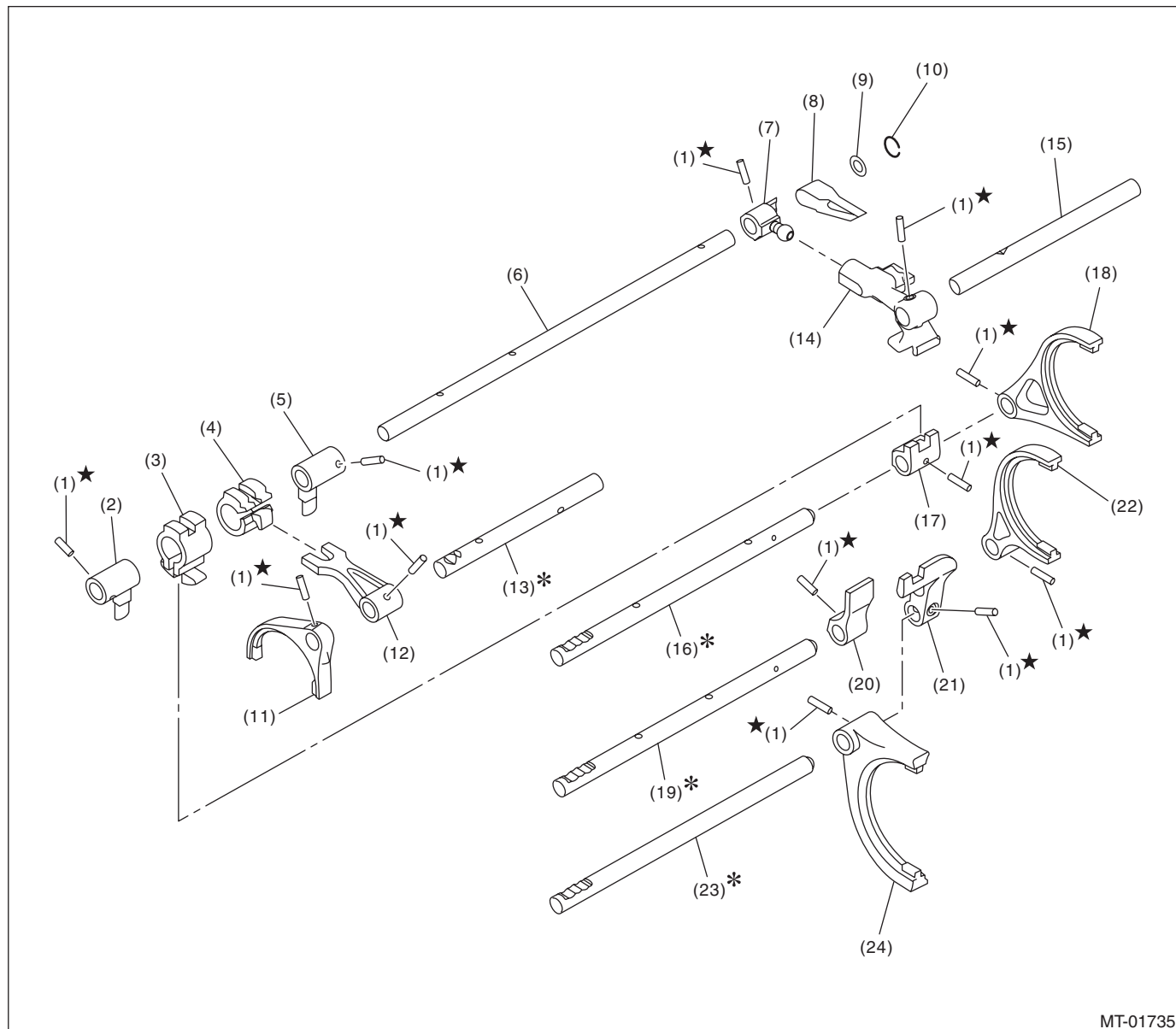

MT-01735

- | | | |
|-----------------------------|--------------------------|--------------------------|
| (1) Spring pin | (9) Washer | (17) 5th-6th shifter arm |
| (2) Interlock arm | (10) Snap ring | (18) 5th-6th fork COMPL |
| (3) Interlock block | (11) Reverse fork COMPL | (19) 3rd-4th fork rod |
| (4) Reverse interlock block | (12) Reverse shifter arm | (20) 3rd-4th shifter arm |
| (5) Interlock arm | (13) Reverse fork rod | (21) 1st-2nd shifter arm |
| (6) Striking rod | (14) Selector arm | (22) 3rd-4th fork COMPL |
| (7) Selector arm No. 2 | (15) Shifter arm shaft | (23) 1st-2nd fork rod |
| (8) Neutral set spring | (16) 5th-6th fork rod | (24) 1st-2nd fork COMPL |

General Description

MANUAL TRANSMISSION AND DIFFERENTIAL

Brought to you by
 NOVA
 SALE
 Brought to you by
 Peris Studios

7. MAIN SHAFT ASSEMBLY

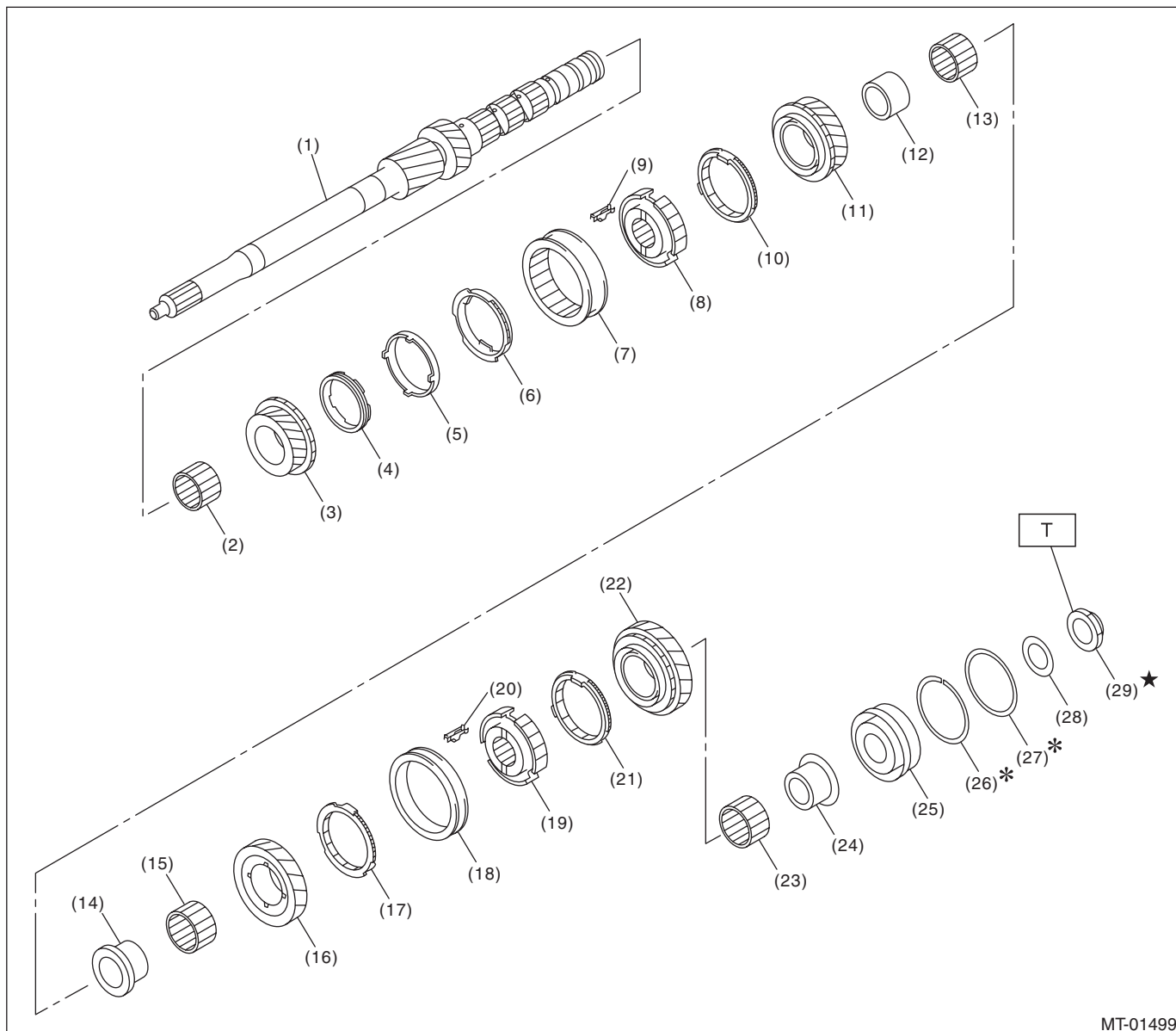

MT-01499

- | | | |
|----------------------|----------------------|---------------------------|
| (1) Main shaft | (12) 4th bushing | (23) Needle bearing |
| (2) Needle bearing | (13) Needle bearing | (24) 6th bushing |
| (3) 3rd drive gear | (14) 5th bushing | (25) Taper roller bearing |
| (4) Inner baulk ring | (15) Needle bearing | (26) Snap ring |
| (5) Synchro cone | (16) 5th drive gear | (27) Washer |
| (6) Outer baulk ring | (17) 5th baulk ring | (28) Washer |
| (7) 3rd-4th sleeve | (18) 5th-6th sleeve | (29) Lock nut |
| (8) 3rd-4th hub | (19) 5th-6th hub | |
| (9) Shifting insert | (20) Shifting insert | |
| (10) 4th baulk ring | (21) 6th baulk ring | |
| (11) 4th gear | (22) 6th drive gear | |

Tightening torque: N·m (kgf·m, ft·lb)

T: 392 (40.0, 289.1)

General Description

MANUAL TRANSMISSION AND DIFFERENTIAL

Brought to you by Eris Studios
NOT FOR RESALE

8. DRIVE PINION AND DRIVE SHAFT ASSEMBLY

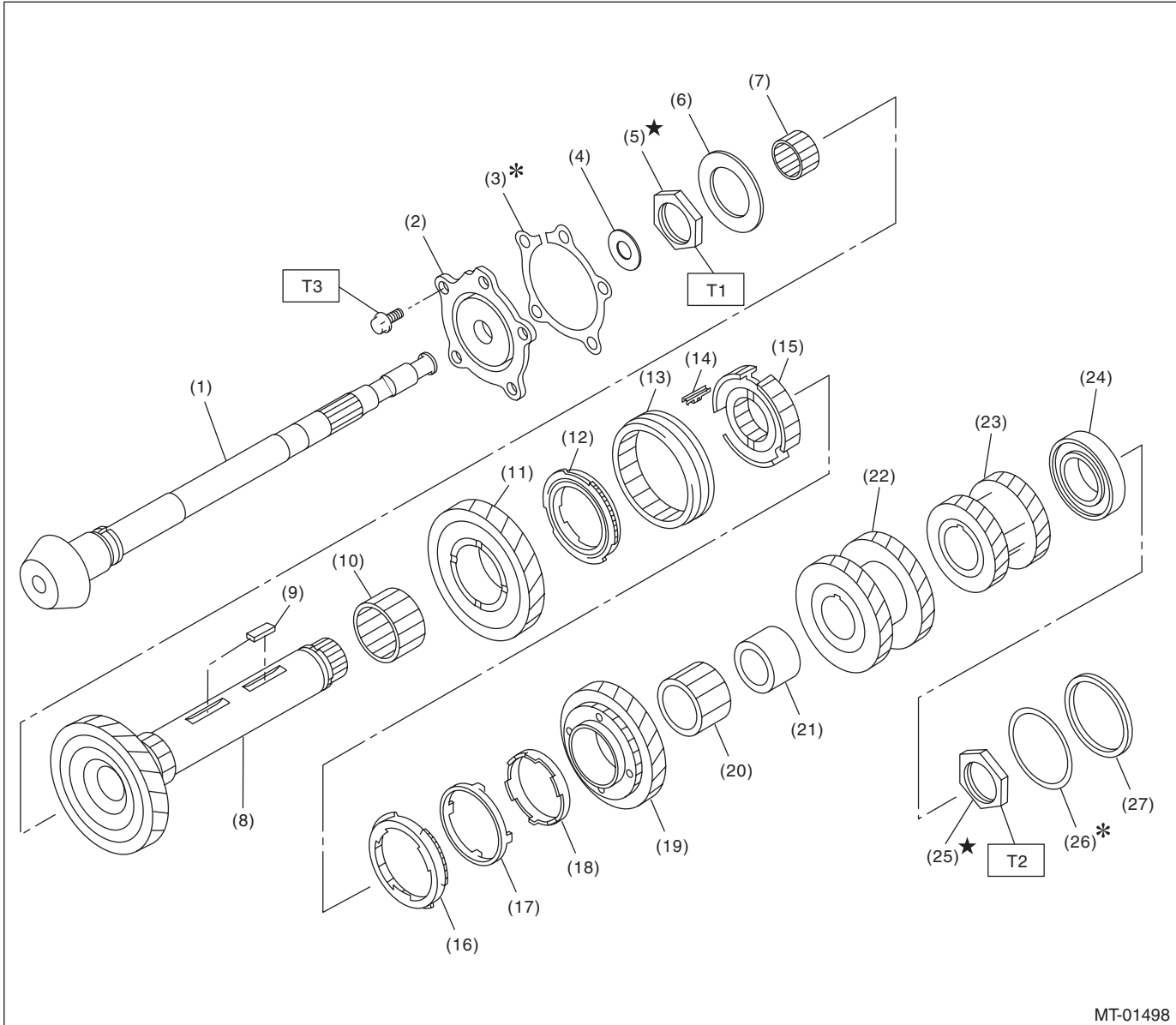

MT-01498

- | | |
|---------------------------|--------------------------|
| (1) Drive pinion shaft | (13) 1st-2nd sleeve |
| (2) Taper roller bearing | (14) Shifting insert |
| (3) Shim | (15) 1st-2nd hub |
| (4) Washer | (16) Outer baulk ring |
| (5) Lock nut | (17) Synchro cone |
| (6) Thrust bearing | (18) Inner baulk ring |
| (7) Needle bearing | (19) 2nd driven gear |
| (8) Driven shaft | (20) Needle bearing |
| (9) Key | (21) 2nd bushing |
| (10) Needle bearing | (22) 3rd-4th driven gear |
| (11) 1st driven gear | (23) 5th-6th driven gear |
| (12) 1st synchronizer set | (24) Ball bearing |

- | |
|---------------|
| (25) Lock nut |
| (26) Shim |
| (27) Collar |

Tightening torque:N-m (kgf-m, ft-lb)

- T1: 285 (29.1, 210.2)**
*** 265 (27.0, 195.4)**
- T2: 570 (58.1, 420.4)**
*** 530 (54.0, 390.9)**
- T3: 54 (5.5, 39.8)**

* Tightening torque when using the ST

General Description

MANUAL TRANSMISSION AND DIFFERENTIAL

Brought to you by
 NOVA
 RESALE
 Meris Studios

9. REVERSE IDLER GEAR ASSY

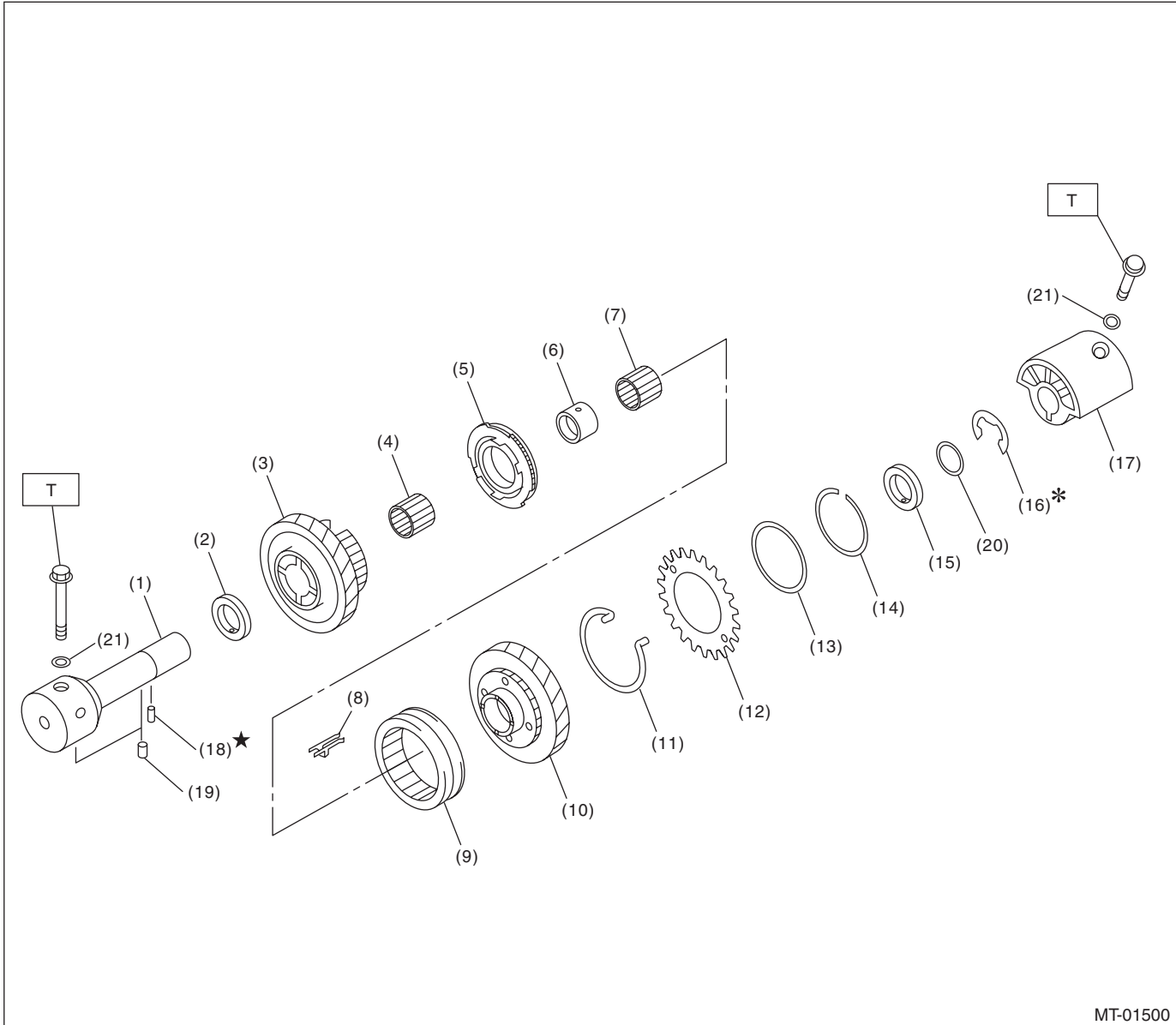

MT-01500

- | | | |
|---------------------------------|----------------------------------|---------------------------|
| (1) Base COMPL | (9) Reverse coupling sleeve | (17) Reverse idler holder |
| (2) Counter high and low washer | (10) Reverse idler gear | (18) Spring pin |
| (3) Reverse idler gear No. 2 | (11) Spring | (19) Knock pin |
| (4) Needle bearing | (12) Sub gear | (20) Washer |
| (5) Reverse idler synchro set | (13) Friction plate | (21) Gasket |
| (6) Reverse idler gear bushing | (14) Snap ring | |
| (7) Needle bearing | (15) Counter high and low washer | |
| (8) Shifting insert | (16) Snap ring | |

Tightening torque: N·m (kgf·m, ft·lb)

T: 25 (2.5, 18.4)

General Description

MANUAL TRANSMISSION AND DIFFERENTIAL

Brought to you by Eris Studios
NOT FOR RESALE

10.FRONT DIFFERENTIAL

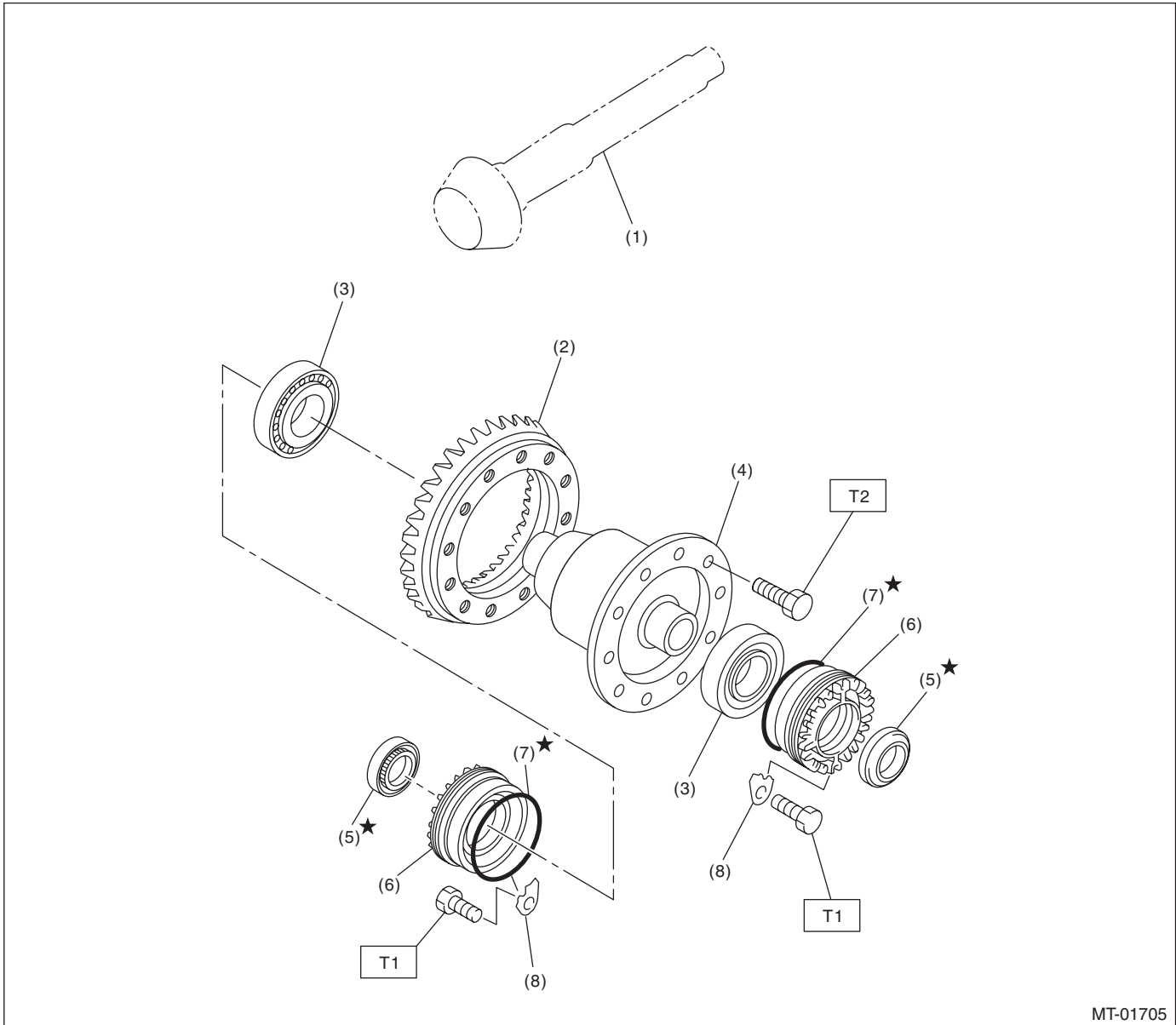

MT-01705

- | | |
|------------------------|--------------------------------|
| (1) Drive pinion shaft | (5) Oil seal |
| (2) Hypoid driven gear | (6) Differential side retainer |
| (3) Roller bearing | (7) O-ring |
| (4) Differential ASSY | (8) Retainer lock plate |

Tightening torque:N-m (kgf-m, ft-lb)
T1: 25 (2.5, 18.4)
T2: 69 (7.0, 50.9)

General Description

MANUAL TRANSMISSION AND DIFFERENTIAL

Brought to you by
NOVA
SALE

11. TRANSMISSION MOUNTING

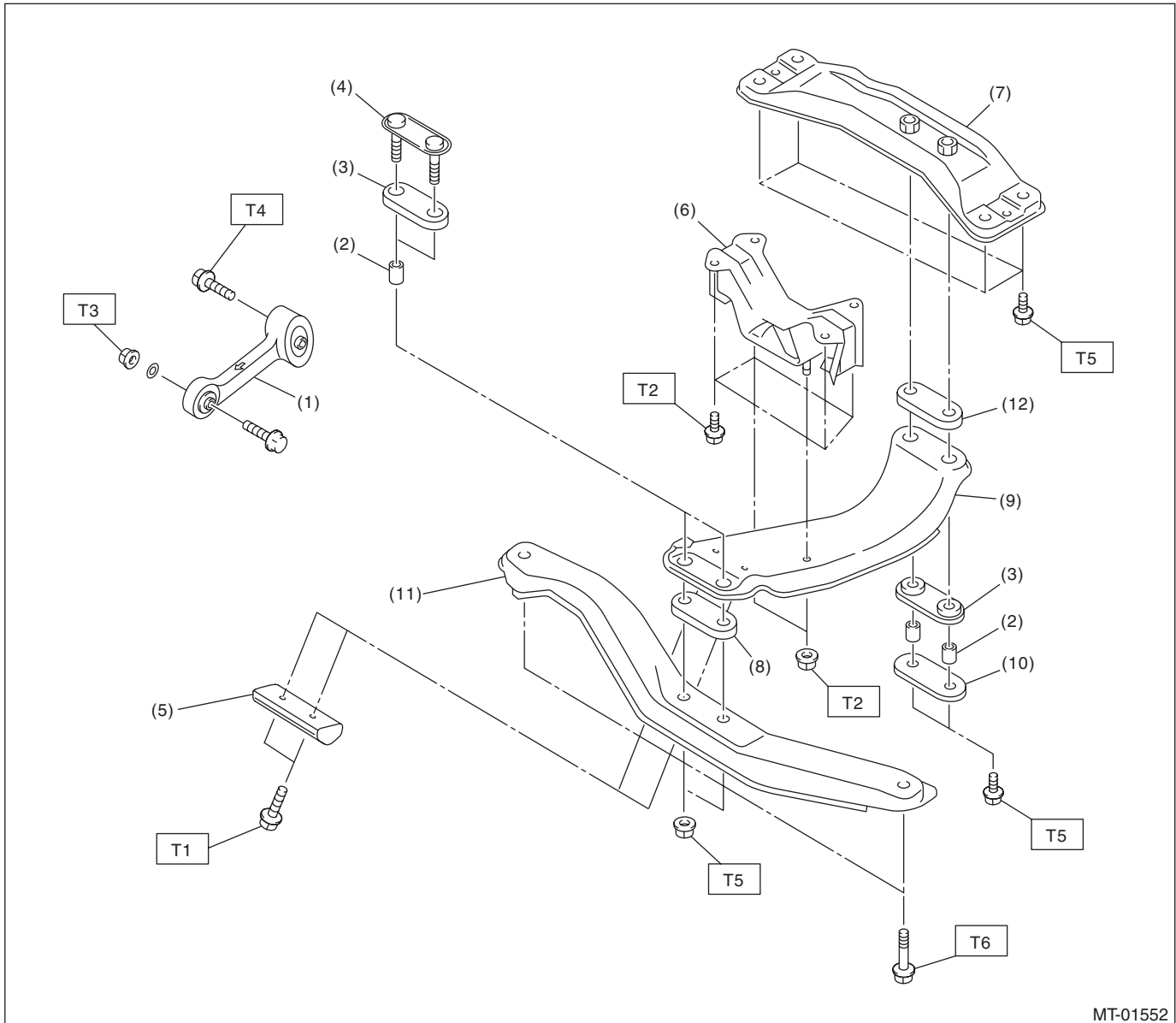

MT-01552

- | | |
|---------------------------------|--------------------------|
| (1) Pitching stopper | (8) Upper cushion rubber |
| (2) Spacer | (9) Center crossmember |
| (3) Lower cushion rubber | (10) Rear plate |
| (4) Front plate | (11) Front crossmember |
| (5) Dynamic damper | (12) Rear cushion rubber |
| (6) Transmission cushion rubber | |
| (7) Rear crossmember | |

Tightening torque: N·m (kgf·m, ft·lb)

T1: 7.5 (0.8, 5.5)

T2: 35 (3.6, 25.8)

T3: 50 (5.1, 36.9)

T4: 58 (5.9, 42.8)

T5: 70 (7.1, 51.6)

T6: 140 (14.3, 103.3)

C: CAUTION

- Wear appropriate work clothing, including a cap, protective goggles and protective shoes when performing any work.
- Remove contamination including dirt and corrosion before removal, installation or disassembly.
- Keep the disassembled parts in order and protect them from dust and dirt.
- Before removal, installation or disassembly, be sure to clarify the abnormal condition. Avoid unnecessary removal, installation, disassembly and replacement.
- When disassembling the case and other light alloy parts, disassemble by using a plastic hammer. Do not pry apart with screwdrivers or other tools.
- Vehicle components are extremely hot after driving. Be wary of receiving burns from heated parts.
- Use SUBARU genuine transmission gear oil, grease or the equivalent. Do not mix transmission gear oil, grease etc. of different grades or manufacturers.
- Be sure to tighten fasteners including bolts and nuts to the specified torque.
- Place shop jacks or rigid racks at the specified points.
- Apply transmission gear oil onto sliding or revolving surfaces before installation.
- Always replace deformed or damaged snap rings.
- Before installing O-rings or oil seals, apply sufficient amount of transmission gear oil to avoid damage and deformation.
- Be careful not to incorrectly install or fail to install O-rings, snap rings and other parts.
- Before securing a part on a vise, place cushioning materials such as wood blocks, aluminum plates, or waste cloth between the part and the vise.
- Avoid damaging the mating surface of the case.
- Before applying liquid gasket, completely remove the old liquid gasket.

General Description

MANUAL TRANSMISSION AND DIFFERENTIAL

Brought to you by
 NOZON
 SALE

D: PREPARATION TOOL

1. SPECIAL TOOL

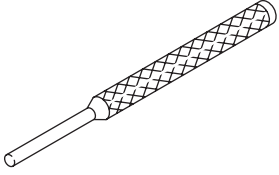
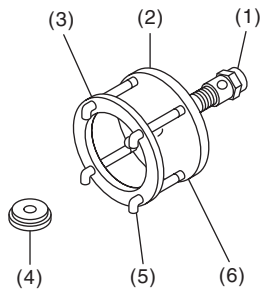
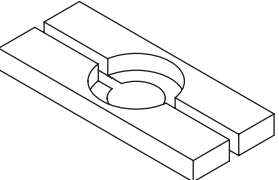
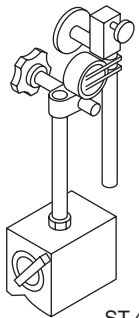
ILLUSTRATION	TOOL NUMBER	DESCRIPTION	REMARKS
 <p>ST-398791700</p>	398791700	REMOVER	Used for removing and installing the spring pin (6 mm).
 <p>ST-399527700</p>	399527700	PULLER SET	Used for removing and installing the roller bearing (Differential). (1) BOLT (899521412) (2) PULLER (399527702) (3) HOLDER (399527703) (4) ADAPTER (398497701) (5) BOLT (899520107) (6) NUT (021008000)
 <p>ST-498515700</p>	498515700	REMOVER	Used for removing the roller bearing of the drive pinion shaft.
 <p>ST-498247001</p>	498247001	MAGNET BASE	<ul style="list-style-type: none"> Used for measuring backlash between the side gear, pinion, and hypoid gear. Used with DIAL GAUGE (498247100).

General Description

MANUAL TRANSMISSION AND DIFFERENTIAL

Brought to you by Eris Studios
NOT FOR RESALE

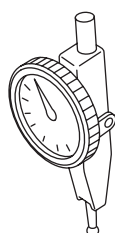
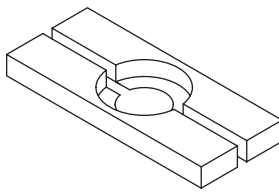
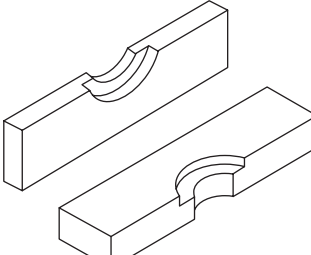
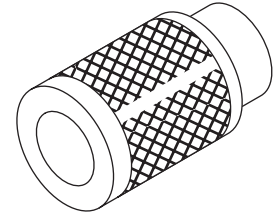
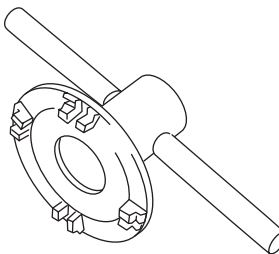
ILLUSTRATION	TOOL NUMBER	DESCRIPTION	REMARKS
 <p>ST-498247100</p>	498247100	DIAL GAUGE	<ul style="list-style-type: none"> Used for measuring backlash between the side gear, pinion, and hypoid gear. Used with MAGNET BASE (498247001).
 <p>ST-498077000</p>	498077000	REMOVER	Used for removing the differential taper roller bearing.
 <p>ST-899858600</p>	899858600	REMOVER	Used for removing the roller bearing.
 <p>ST-499757002</p>	499757002	INSTALLER	Used for installing the bearing cone of the transfer driven gear (extension core side).
 <p>ST18630AA010</p>	18630AA010	WRENCH COMPL RETAINER	<ul style="list-style-type: none"> Used for removing and installing the differential side retainer RH. WRENCH ASSEMBLY (499787000) can also be used.

General Description

MANUAL TRANSMISSION AND DIFFERENTIAL

Brought to you by
 NOT FOR SALE
 Chris Studios

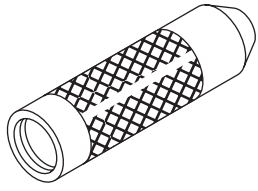
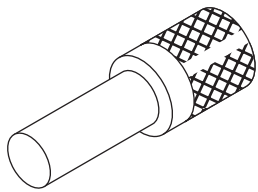
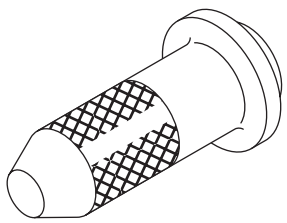
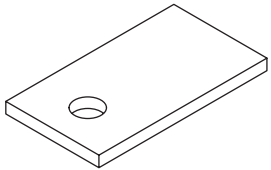
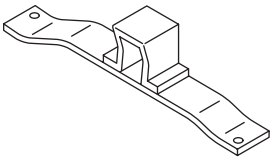
ILLUSTRATION	TOOL NUMBER	DESCRIPTION	REMARKS
 <p data-bbox="337 520 467 541">ST-499877000</p>	499877000	RACE 4-5 INSTALLER	Used for disassembling the driven shaft and transfer driven gear.
 <p data-bbox="337 873 467 894">ST-899864100</p>	899864100	REMOVER	Used for removing the transmission main shaft and drive pinion parts.
 <p data-bbox="337 1226 467 1247">ST-498057300</p>	498057300	INSTALLER	Used for installing the extension oil seal.
 <p data-bbox="337 1579 467 1600">ST-498255400</p>	498255400	PLATE	Used for measuring backlash.
 <p data-bbox="324 1923 467 1944">ST41099AA010</p>	41099AA010	ENGINE SUPPORT BRACKET	Used for supporting engine.

General Description

MANUAL TRANSMISSION AND DIFFERENTIAL

Brought to you by Eris Studios
NOT FOR RESALE

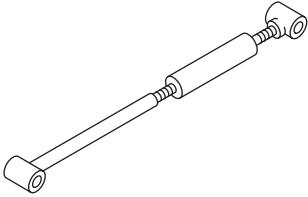
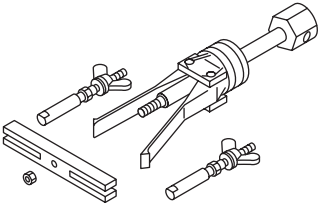
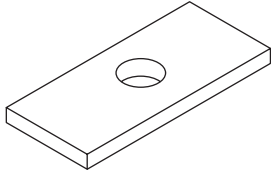
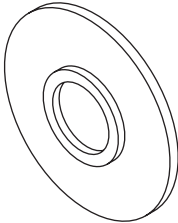
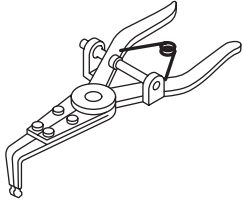
ILLUSTRATION	TOOL NUMBER	DESCRIPTION	REMARKS
 <p>ST41099AA020</p>	41099AA020	ENGINE SUPPORT	Used for supporting engine.
 <p>ST-398527700</p>	398527700	PULLER ASSY	Used for removing the extension case oil seal and the front side retainer bearing outer race.
 <p>ST-398643600</p>	398643600	GAUGE	Used for measuring the total end play, extension end play and drive pinion height.
 <p>ST-398177700</p>	398177700	INSTALLER	Used for assembling the main shaft.
 <p>ST-399893600</p>	399893600	PLIER	<ul style="list-style-type: none"> • Used for removing and installing the neutral set spring. • Used together with the CLAW (18756AA000).

General Description

MANUAL TRANSMISSION AND DIFFERENTIAL

Brought to you by
 NOVA
 RESALE
 Brought to you by
 Peris Studios

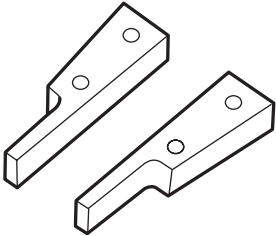
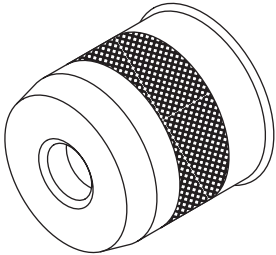
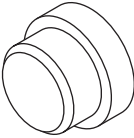
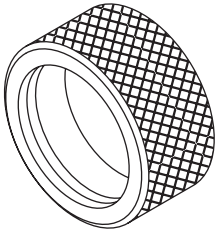
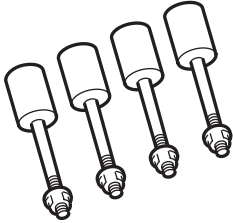
ILLUSTRATION	TOOL NUMBER	DESCRIPTION	REMARKS
 <p data-bbox="326 520 467 543">ST18756AA000</p>	18756AA000	CLAW	<ul style="list-style-type: none"> • Used for removing and installing the neutral set spring. • Used together with PLIER (399893600).
 <p data-bbox="337 871 467 894">ST-499247400</p>	499247400	INSTALLER	Used for installing the ball bearing of the transfer drive gear.
 <p data-bbox="337 1224 467 1247">ST-398497701</p>	398497701	SEAT	Used for installing the ball bearing of the transfer drive gear.
 <p data-bbox="337 1577 467 1600">ST-398437700</p>	398437700	INSTALLER	Used for installing the front differential side bearing.
 <p data-bbox="326 1923 467 1946">ST18632AA000</p>	18632AA000	STAND ASSY	Used for disassembling and assembling the transmission.

General Description

MANUAL TRANSMISSION AND DIFFERENTIAL

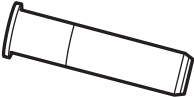
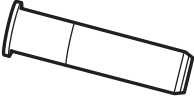
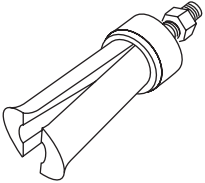
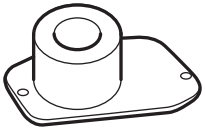

Brought to you by Eris Studios
NOT FOR RESALE

ILLUSTRATION	TOOL NUMBER	DESCRIPTION	REMARKS
 ST18671AA000	18671AA000	OIL SEAL GUIDE	<ul style="list-style-type: none"> • Used for installing the oil seal to the reverse check. • Used together with the INSTALLER (18657AA010).
 ST18657AA010	18657AA010	INSTALLER	<ul style="list-style-type: none"> • Used for installing the oil seal to the reverse check. • Used together with the OIL SEAL GUIDE (18671AA000).
 ST18657AA000	18657AA000	INSTALLER	Used for installing the oil seal to the shift rod.
 ST18758AA000	18758AA000	PULLER	Used for removing the extension taper roller bearing outer race.
 ST18831AA000	18831AA000	GAUGE	Used for measuring the extension taper roller bearing.

General Description

MANUAL TRANSMISSION AND DIFFERENTIAL

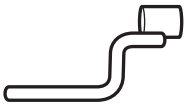

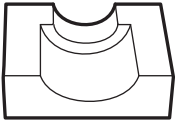
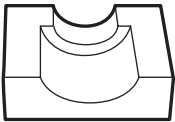
Brought to you by
 NOVA
 RESALE
 is Studios

ILLUSTRATION	TOOL NUMBER	DESCRIPTION	REMARKS
 ST18631AA000	18631AA000	HANDLE	Used for measuring the front differential backlash.
 ST18754AA000	18754AA000	REMOVER	Used to remove parts of the driven gear.
 ST18757AA000	18757AA000	STRAIGHT PIN REMOVER	Used for installing the reverse idler gear.
 ST18665AA000	18665AA000	HOLDER	<ul style="list-style-type: none"> Used for removing and installing the main shaft lock nut. Used together with the BASE (18664AA000).
 ST18666AA000	18666AA000	HOLDER	<ul style="list-style-type: none"> Used for removing and installing the driven shaft lock nut. Used together with the BASE (18664AA000).

General Description

MANUAL TRANSMISSION AND DIFFERENTIAL

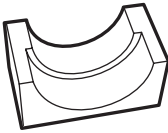
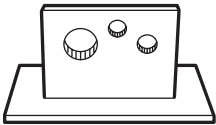

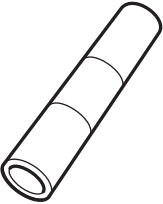
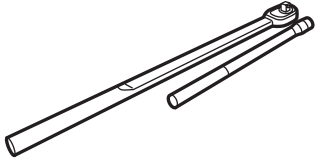
Brought to you by Eris Studios
NOT FOR RESALE

ILLUSTRATION	TOOL NUMBER	DESCRIPTION	REMARKS
 <p>ST18667AA000</p>	18667AA000	HOLDER	<ul style="list-style-type: none"> Used for removing and installing the drive pinion shaft lock nut. Used together with the BASE (18664AA000).
 <p>ST18664AA000</p>	18664AA000	BASE	<ul style="list-style-type: none"> Used for removing and installing the main shaft lock nut. Used for removing and installing the drive pinion shaft lock nut. Used for removing and installing the driven shaft lock nut.
 <p>ST18722AA010</p>	18722AA010	REMOVER	Used for disassembling the main shaft.
 <p>ST18651AA000</p>	18651AA000	INSTALLER	Used for assembling the main shaft.
 <p>ST18852AA000</p>	18852AA000	TORQUE WRENCH	<ul style="list-style-type: none"> Used to tighten the main shaft lock nut. Used to tighten the drive pinion shaft lock nut. Used to tighten the driven shaft lock nut.

General Description

MANUAL TRANSMISSION AND DIFFERENTIAL

Brought to you by
 NOVA Series Studios
 NOT FOR RESALE

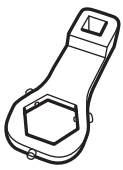
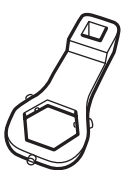
ILLUSTRATION	TOOL NUMBER	DESCRIPTION	REMARKS
 <p>ST18668AA000</p>	18668AA000	PUNCH	Used to crimp the main shaft lock nut.
 <p>ST18669AA000</p>	18669AA000	PUNCH	Used to crimp the driven shaft lock nut.
 <p>ST18670AA000</p>	18670AA000	PUNCH	Used to crimp the drive pinion shaft lock nut.
 <p>ST18620AA000</p>	18620AA000	ADAPTER WRENCH	Used for removing and installing the driven gear shaft lock nut.
 <p>ST18621AA000</p>	18621AA000	ADAPTER WRENCH	Used for removing and installing the drive pinion shaft lock nut.

General Description

MANUAL TRANSMISSION AND DIFFERENTIAL

Brought to you by Eris Studios
NOT FOR RESALE

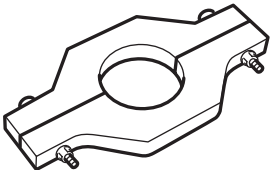
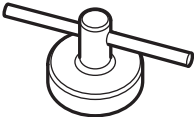
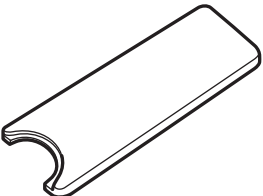
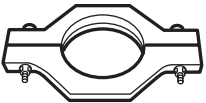
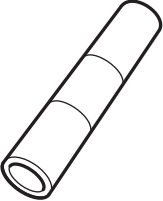
ILLUSTRATION	TOOL NUMBER	DESCRIPTION	REMARKS
 <p style="text-align: center; font-size: small;">ST18723AA000</p>	18723AA000	REMOVER	Used for disassembling the driven shaft.
 <p style="text-align: center; font-size: small;">ST18630AA000</p>	18630AA000	WRENCH ASSY	Used for removing and installing the differential side retainer LH.
 <p style="text-align: center; font-size: small;">ST18672AA000</p>	18672AA000	GUIDE CLIP	Used for installing the reverse idler snap ring.
 <p style="text-align: center; font-size: small;">ST18720AA000</p>	18720AA000	REMOVER	Used for disassembling the main shaft.
 <p style="text-align: center; font-size: small;">ST18654AA000</p>	18654AA000	INSTALLER	Used for assembling the driven shaft.

General Description

MANUAL TRANSMISSION AND DIFFERENTIAL

Brought to you by
 NOZON
 RESALE
 is Studios

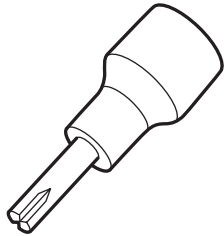
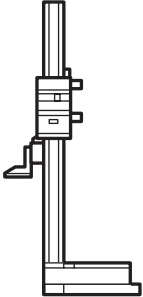
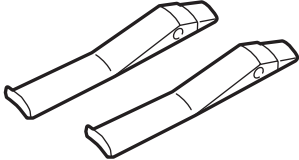
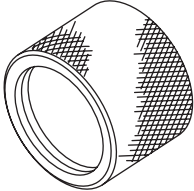
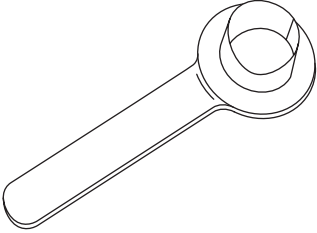
ILLUSTRATION	TOOL NUMBER	DESCRIPTION	REMARKS
 <p>ST18663AA000</p>	18663AA000	SOCKET	Used for removing and installing the transfer bearing holder.
 <p>ST18853AA000</p>	18853AA000	HEIGHT GAUGE	Used for selecting the shift rod.
 <p>ST18760AA000</p>	18760AA000	CLAW	<ul style="list-style-type: none"> • Used for removing the front side retainer bearing outer race. • Used together with PULLER ASSY (398527700).
 <p>ST18675AA000</p>	18675AA000	DIFFERENTIAL SIDE OIL SEAL INSTALLER	Used for installing the differential side retainer oil seal.
 <p>ST28399SA010</p>	28399SA010	OIL SEAL PROTECTOR	Used for protecting oil seal when installing front drive shaft.

General Description

MANUAL TRANSMISSION AND DIFFERENTIAL

Brought to you by Eris Studios
NOT FOR RESALE

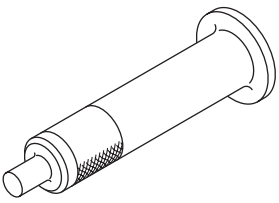
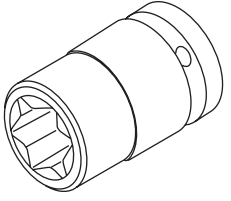
ILLUSTRATION	TOOL NUMBER	DESCRIPTION	REMARKS
 ST18657AA020	18657AA020	OIL SEAL INSTALLER	Used for installing the oil seal.
 ST18270KA020	18270KA020	SOCKET (E20)	Used for removing and installing the hypoid driven gear.

2. GENERAL TOOL

TOOL NAME	REMARKS
Circuit tester	Used for measuring resistance, voltage and current.
TORX® bit T70	Used for removing and installing transmission gear oil drain plug.
Depth gauge	Used for measuring the transmission end play.

Transmission Gear Oil

MANUAL TRANSMISSION AND DIFFERENTIAL

Brought to you by
NOVA Studios
NOT FOR SALE

2. Transmission Gear Oil

A: INSPECTION

- 1) Lift up the vehicle.
- 2) Remove the transmission under cover.
- 3) Remove the filler plug, and then check the transmission gear oil.

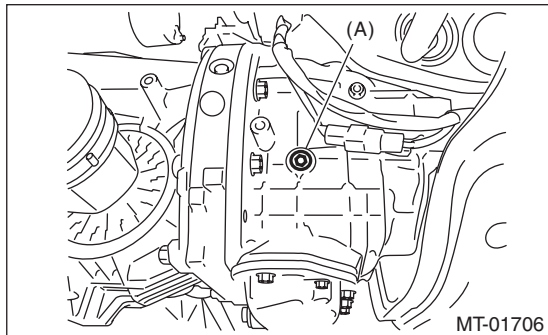

(A) Filler plug

- 4) Check that the transmission gear oil level is up to the bottom of the filler plug. If the transmission gear oil level is low, refill up to the bottom of filler plug.
- 5) Using a new gasket, and tighten the filler plug.

Tightening torque:

50 N·m (5.1 kgf·m, 36.9 ft·lb)

B: REPLACEMENT

- 1) Lift up the vehicle.
- 2) Remove the transmission under cover.
- 3) Remove the filler plug.

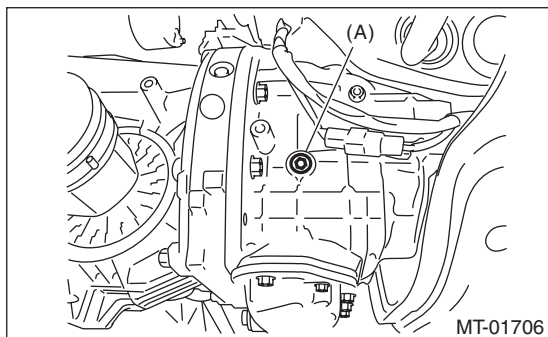

(A) Filler plug

- 4) Remove the two drain plugs (oil pan side, clutch housing side), and then drain the transmission gear oil completely.

CAUTION:

- Immediately after the engine has been running, the transmission gear oil is hot. Be careful not to burn yourself.
- Be careful not to spill the transmission gear oil on exhaust pipe to prevent it from emitting smoke or causing fires. If transmission gear oil is spilled on the exhaust pipe, wipe it off completely.

NOTE:

- Tighten the drain plug of the transmission gear oil after draining the transmission gear oil.
- Always use a new gasket.
- Use TORX® bit T70 to remove and install the drain plug on clutch housing side.

Tightening torque:

Oil pan side

50 N·m (5.1 kgf·m, 36.9 ft·lb)

Clutch housing side

70 N·m (7.1 kgf·m, 51.6 ft·lb)

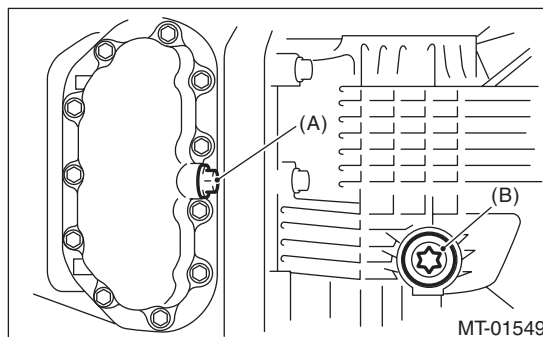

(A) Drain plug (oil pan side)

(B) Drain plug (clutch housing side)

- 5) Pour transmission gear oil to the bottom end of filler plug.

NOTE:

Carefully refill transmission gear oil while checking the level. Excessive or insufficient oil must be avoided.

RECOMMENDED GEAR OIL

Use GL-5 or the equivalent.

Transmission gear oil capacity

4.1 ℓ (4.3 US qt, 3.6 Imp qt)

- 6) Check the level of the transmission gear oil.
- 7) Using a new gasket, and tighten the filler plug.

Tightening torque:

50 N·m (5.1 kgf·m, 36.9 ft·lb)

3. Oil Seal

A: INSPECTION

Check that there is no oil leaking from the oil seal. If there is any deformation, hardening, wear or other malfunctions of the oil seal, perform the following:

- Replace the oil seal.
- Inspect the propeller shaft.

B: REPLACEMENT

- 1) Clean the transmission exterior.
- 2) Drain transmission gear oil completely. <Ref. to 6MT-27, REPLACEMENT, Transmission Gear Oil.>
- 3) Remove the rear exhaust pipe and muffler.
- 4) Remove the heat shield cover.
- 5) Remove the propeller shaft. <Ref. to DS-10, REMOVAL, Propeller Shaft.>
- 6) Using the ST, remove the oil seal.
ST 398527700 PULLER ASSY

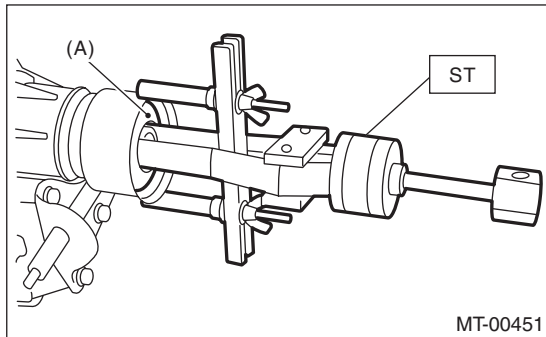

(A) Oil seal

- 7) Using the ST, install the oil seal.
ST 498057300 INSTALLER

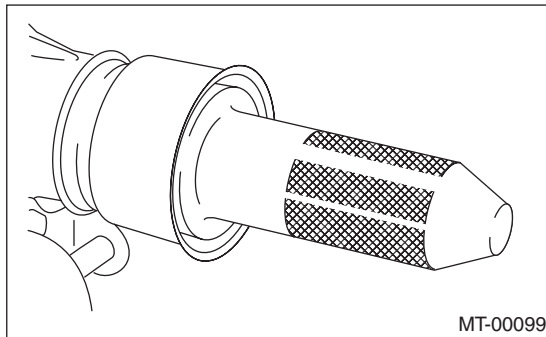

- 8) Install the propeller shaft. <Ref. to DS-11, INSTALLATION, Propeller Shaft.>
- 9) Install the heat shield cover.
- 10) Install the rear exhaust pipe and muffler.
- 11) Pour in transmission gear oil and check the oil level. <Ref. to 6MT-27, REPLACEMENT, Transmission Gear Oil.>

Brought to you by
Chris Studios
NOT FOR SALE

4. Differential Side Retainer Oil Seal

A: INSPECTION

Check that there is no oil leaking from the differential side retainer oil seal. If there is oil leakage, perform the following procedures.

- Replace the oil seal.
- Check the front drive shaft.

B: REPLACEMENT

- 1) Lift up the vehicle.
- 2) Remove the front exhaust pipe and center exhaust pipe. <Ref. to EX(STI)-5, REMOVAL, Front Exhaust Pipe.>
- 3) Drain transmission gear oil completely. <Ref. to 6MT-27, REPLACEMENT, Transmission Gear Oil.>
- 4) Separate the front drive shaft from the transmission. <Ref. to DS-25, REMOVAL, Front Drive Shaft.>
- 5) Remove the differential side retainer oil seal by using a flat tip screwdriver or similar tools.
- 6) Using the ST, install the differential side retainer oil seal by lightly tapping with a hammer.
ST 18675AA000 DIFFERENTIAL SIDE OIL SEAL INSTALLER
- 7) Apply transmission gear oil to the oil seal lips.
- 8) Set the ST to the side retainer.
ST 28399SA010 OIL SEAL PROTECTOR
- 9) Install the front drive shaft into the transmission.

NOTE:

- Replace the circlip of drive shaft with a new part.
- 10) Install the front drive shaft into transmission, remove the ST and insert the drive shaft securely.
ST 28399SA010 OIL SEAL PROTECTOR
 - 11) Install the front exhaust pipe and the center exhaust pipe. <Ref. to EX(STI)-6, INSTALLATION, Front Exhaust Pipe.>
 - 12) Pour transmission gear oil to the bottom end of filler plug. <Ref. to 6MT-27, REPLACEMENT, Transmission Gear Oil.>
 - 13) Lower the vehicle.

Transmission Mounting System

MANUAL TRANSMISSION AND DIFFERENTIAL

Brought to you by Eris Studios
NOT FOR RESALE

5. Transmission Mounting System

A: REMOVAL

1. PITCHING STOPPER

- 1) Disconnect the ground cable from the battery.
- 2) Remove the intercooler. <Ref. to IN(STI)-11, REMOVAL, Intercooler.>
- 3) Remove the pitching stopper.

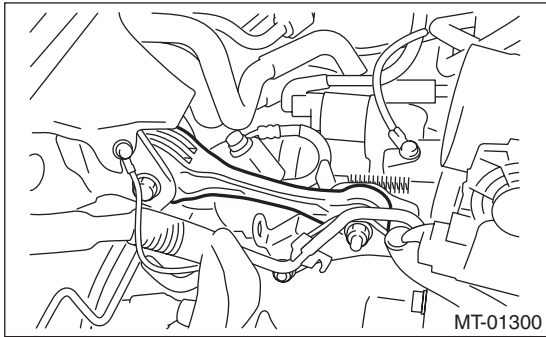

2. CROSSMEMBER AND CUSHION RUBBER

- 1) Disconnect the ground cable from the battery.
- 2) Lift up the vehicle.
- 3) Remove the transmission under cover.
- 4) Remove the center exhaust pipe. <Ref. to EX(STI)-7, REMOVAL, Center Exhaust Pipe.>
- 5) Remove the rear exhaust pipe and muffler. <Ref. to EX(STI)-12, REMOVAL, Rear Exhaust Pipe.> <Ref. to EX(STI)-14, REMOVAL, Muffler.>
- 6) Remove the heat shield cover.
- 7) Set the transmission jack under the transmission body.

CAUTION:

Always support the transmission case with a transmission jack.

- 8) Remove the rear crossmember.

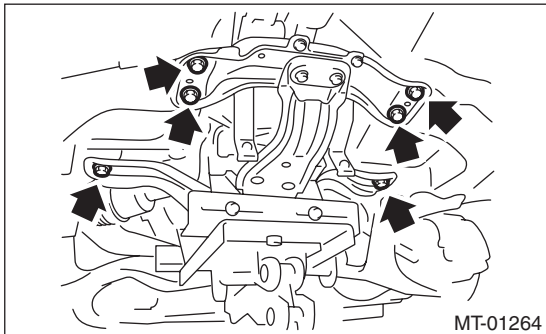

- 9) Remove the rear cushion rubber.

B: INSTALLATION

1. PITCHING STOPPER

- 1) Install the pitching stopper.

Tightening torque:

T1: 50 N·m (5.1 kgf-m, 36.9 ft-lb)

T2: 58 N·m (5.9 kgf-m, 42.8 ft-lb)

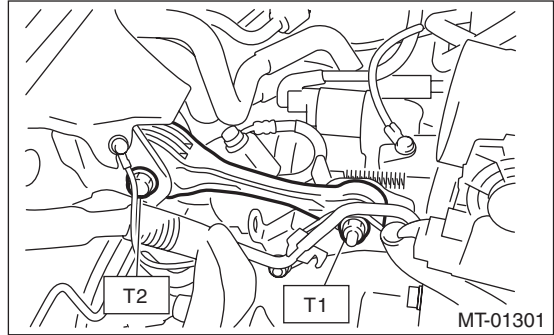

- 2) Install the intercooler. <Ref. to IN(STI)-12, INSTALLATION, Intercooler.>
- 3) Connect the battery ground cable to the battery.

2. CROSSMEMBER AND CUSHION RUBBER

- 1) Install the rear cushion rubber.

Tightening torque:

35 N·m (3.6 kgf-m, 25.8 ft-lb)

- 2) Install the crossmember.

Tightening torque:

T1: 70 N·m (7.1 kgf-m, 51.6 ft-lb)

T2: 140 N·m (14.3 kgf-m, 103 ft-lb)

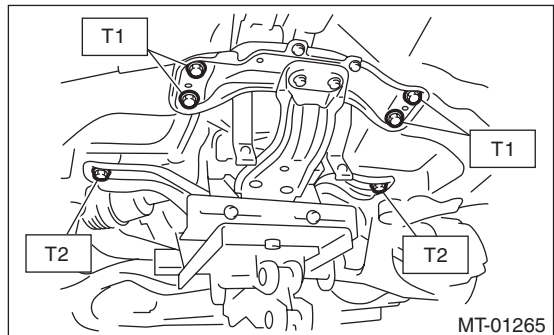

- 3) Remove the transmission jack.
- 4) Install the heat shield cover.
- 5) Install the rear exhaust pipe and muffler. <Ref. to EX(STI)-12, INSTALLATION, Rear Exhaust Pipe.> <Ref. to EX(STI)-14, INSTALLATION, Muffler.>
- 6) Install the center exhaust pipe. <Ref. to EX(STI)-8, INSTALLATION, Center Exhaust Pipe.>

Brought to you by
Chris Studios
NOT FOR SALE

C: INSPECTION

Perform the following inspection procedures and repair or replace faulty parts.

1. PITCHING STOPPER

Check the pitching stopper for bends or damage. Check that the rubber is not stiff, cracked or otherwise damaged.

2. CROSSMEMBER AND CUSHION RUBBER

Check crossmember for bends or damage. Check that the cushion rubber is not stiff, cracked, or otherwise damaged.

Manual Transmission Assembly

MANUAL TRANSMISSION AND DIFFERENTIAL

Brought to you by Eris Studios
NOT FOR RESALE

6. Manual Transmission Assembly

A: REMOVAL

- 1) Set the vehicle on a lift.
- 2) Open the front hood completely.
- 3) Disconnect the ground cable from the battery.
- 4) Remove the intercooler. <Ref. to IN(STI)-11, REMOVAL, Intercooler.>
- 5) Disconnect the following harness connectors, and then remove the engine hanger rear.

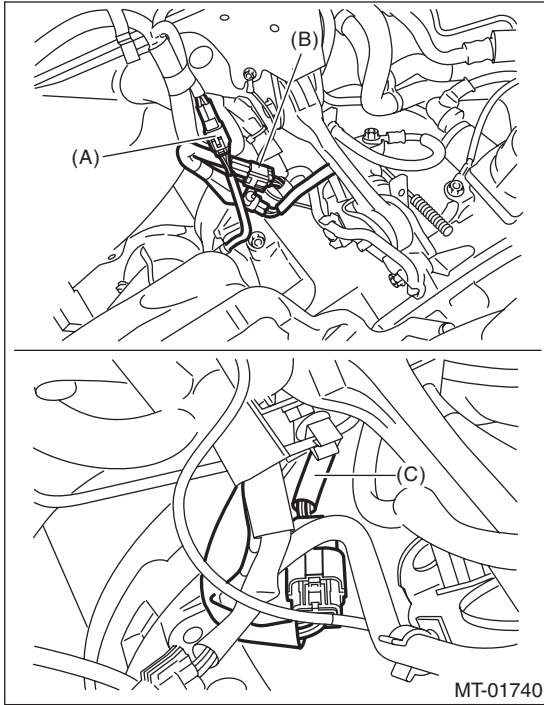

- (A) Front oxygen (A/F) sensor connector
- (B) Rear oxygen sensor connector
- (C) Neutral position switch backup light switch connector

- 6) Remove the secondary air combination valve. <Ref. to EC(STI)-23, SECONDARY AIR COMBINATION VALVE LH, REMOVAL, Secondary Air Combination Valve.>

- 7) Disconnect the ground cable on the upper side of the transmission case and body.

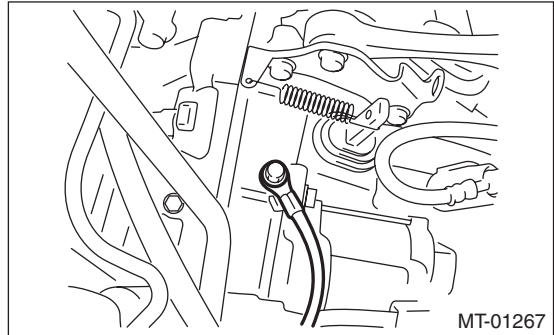
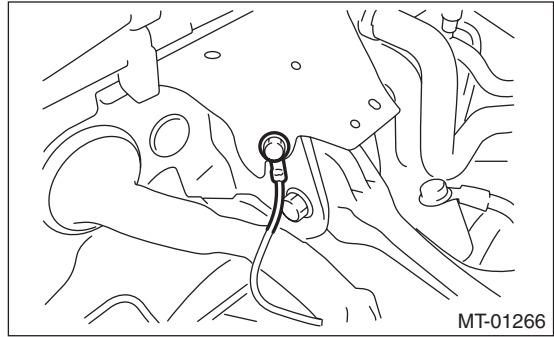

- 8) Remove the starter assembly. <Ref. to SC(STI)-5, REMOVAL, Starter.>
- 9) Remove the operating cylinder from the transmission.

NOTE:
Hang the removed operating cylinder with a piece of wire.

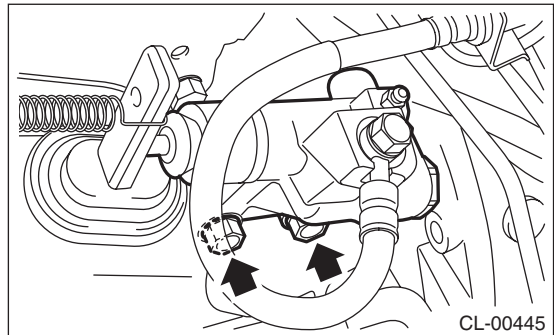

- 10) Remove the pitching stopper and pitching stopper bracket.

Manual Transmission Assembly

MANUAL TRANSMISSION AND DIFFERENTIAL

Brought to you by
NOVA
SALE
Meris Studios

11) Set the ST.

ST1 41099AA010 ENGINE SUPPORT
BRACKET

ST2 41099AA020 ENGINE SUPPORT

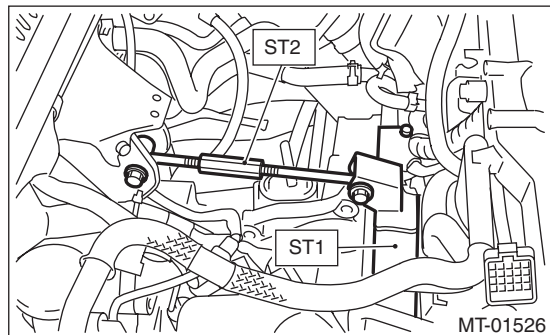

12) Remove the clutch release shaft.

- (1) Remove the plug using a hexagon wrench.
- (2) Attach a 6 mm (0.24 in) bolt to the release shaft, and pull out the release shaft.
- (3) Lift the release fork, and remove from the claw of the release bearing. Pull the release fork to the engine side, and make it so that it moves freely.

13) Remove the front wheels.

14) Lift up the vehicle, and remove the transmission under cover.

15) Drain transmission gear oil completely. <Ref. to 6MT-27, REPLACEMENT, Transmission Gear Oil.>

16) Remove the center exhaust pipe. <Ref. to EX(STI)-7, REMOVAL, Center Exhaust Pipe.>

17) Remove the rear exhaust pipe and muffler. <Ref. to EX(STI)-12, REMOVAL, Rear Exhaust Pipe.> <Ref. to EX(STI)-14, REMOVAL, Muffler.>

CAUTION:

When removing the exhaust pipes, be careful each exhaust pipe does not drop out.

18) Remove the bolts which hold upper side of transmission to engine.

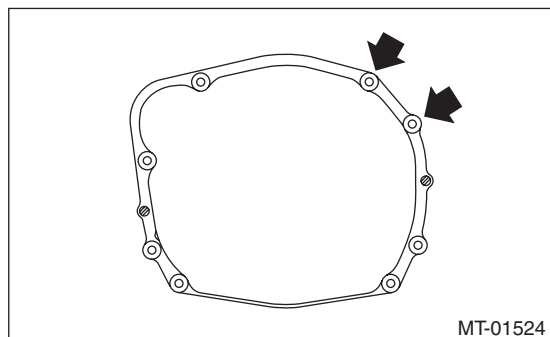

19) Remove the heat shield cover.

20) Remove the propeller shaft. <Ref. to DS-10, REMOVAL, Propeller Shaft.>

21) Remove the front stabilizer link.

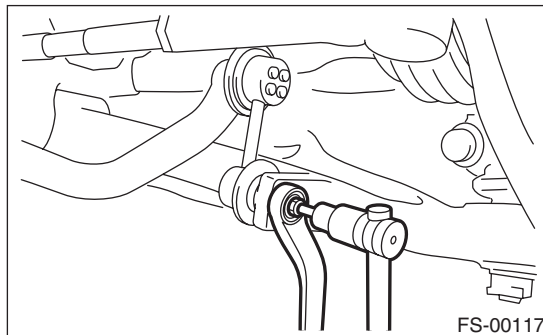

22) Remove the ball joint of front arm from the housing.

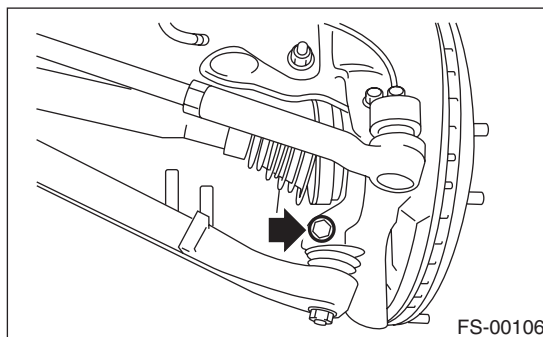

23) Remove the front drive shaft. <Ref. to DS-25, REMOVAL, Front Drive Shaft.>

24) Set the transmission jack under the transmission, and remove the front crossmember and rear crossmember.

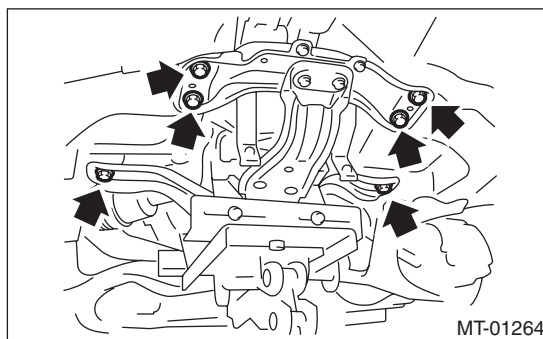

Manual Transmission Assembly

Brought to you by Eris Studios
NOT FOR RESALE

MANUAL TRANSMISSION AND DIFFERENTIAL

25) Move the transmission to the right side of the vehicle, and remove the joint COMPL, stay bolts and reverse check cable.

NOTE:

If the transmission is not moved aside, the joint COMPL and stay bolts may contact the body and cause damage.

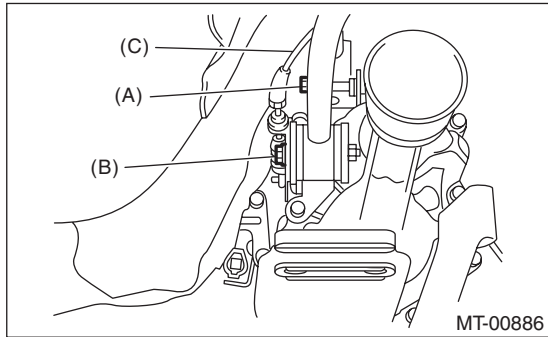

- (A) Joint COMPL bolt
- (B) Stay bolt
- (C) Reverse check cable

26) Tighten the turnbuckle of the ST to tilt the engine assembly towards the back.

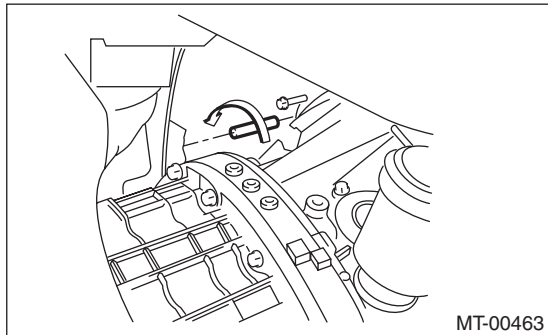

27) Remove the bolts and nuts holding the bottom of transmission to the engine, and remove the transmission from the vehicle.

NOTE:

- During removal, be careful not to hit the transmission against the body when pulling towards the rear.
- The clutch pipe and breather pipe may interfere with each other. Remove carefully.

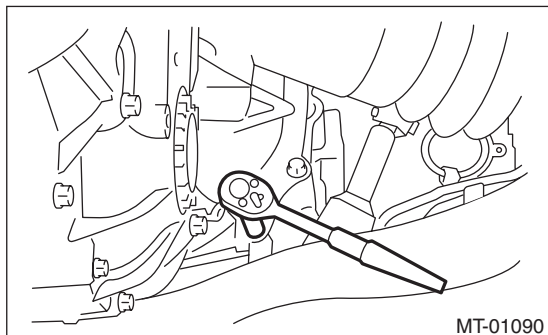

B: INSTALLATION

1) Set the release fork, release bearing and release shaft to the transmission. <Ref. to CL-11, INSTALLATION, Release Bearing and Lever.>

2) Replace the front differential side retainer oil seal.

(1) Remove the oil seal by using flat tip screwdriver etc.

(2) Apply gear oil to the lip of new oil seals.

(3) Install a new oil seal using ST.

ST 18675AA000 DIFFERENTIAL SIDE OIL SEAL INSTALLER

NOTE:

Be sure to replace the differential side oil seal after the procedure of removing front drive shaft from transmission.

3) Loosen the turnbuckle of ST to return the engine to its original position.

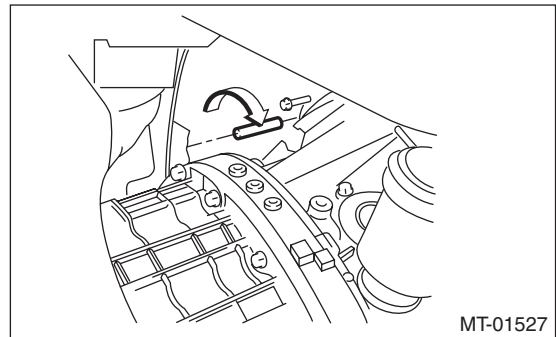

4) Install the transmission.

5) Tighten the bolts and nuts which hold the lower side of transmission to the engine.

NOTE:

- Make sure that the main shaft spline is completely inserted.
- Make sure that the rear end of the engine is set low.

Tightening torque:

50 N·m (5.1 kgf-m, 36.9 ft-lb)

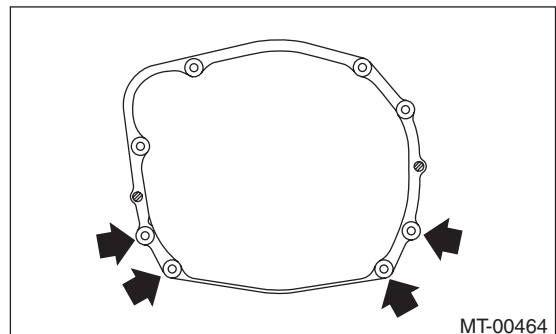

Manual Transmission Assembly

MANUAL TRANSMISSION AND DIFFERENTIAL

Brought to you by
NOVUS
RESALE Studios

6) Move the transmission to the right side of the vehicle, and attach the joint COMPL, stay bolts and reverse check cable.

Tightening torque:

T1: 11.8 N·m (1.2 kgf-m, 8.7 ft-lb)

T2: 32 N·m (3.3 kgf-m, 23.6 ft-lb)

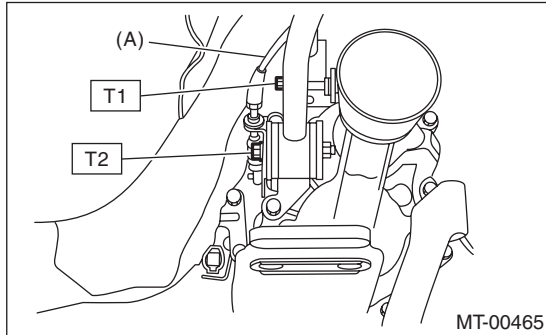

(A) Reverse check cable

7) Install the front crossmember and rear crossmember.

Tightening torque:

T1: 70 N·m (7.1 kgf-m, 51.6 ft-lb)

T2: 140 N·m (14.3 kgf-m, 103 ft-lb)

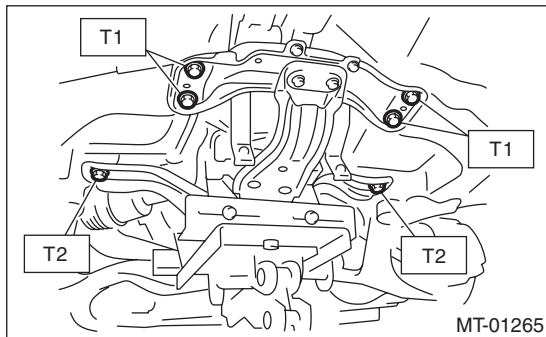

8) Tighten the bolts which hold upper side of the transmission to the engine.

Tightening torque:

50 N·m (5.1 kgf-m, 36.9 ft-lb)

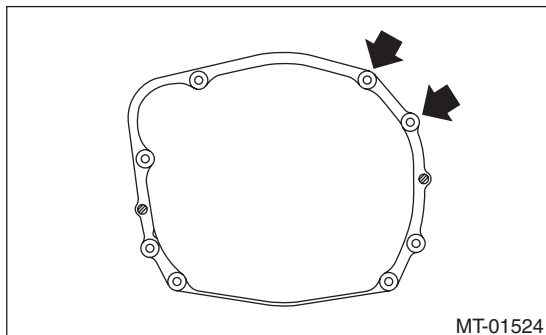

9) Make sure that the release bearing is completely inserted.

NOTE:

- Push the release fork towards the operating cylinder side until a clicking sound is heard. Pull the release fork towards the engine side. If the release fork is not in contact with the case, the setting is complete.
- Confirm that the boot cover is set securely.

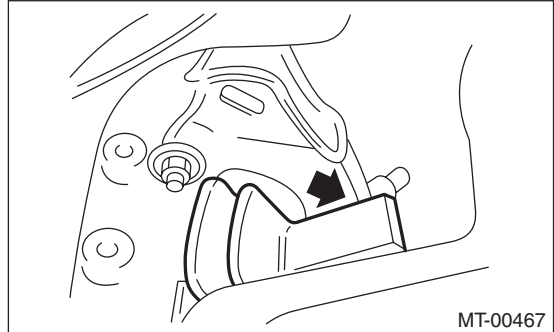

10) Install the pitching stopper bracket.

Tightening torque:

41 N·m (4.2 kgf-m, 30.2 ft-lb)

11) Attach the pitching stopper.

Tightening torque:

T1: 50 N·m (5.1 kgf-m, 36.9 ft-lb)

T2: 58 N·m (5.9 kgf-m, 42.8 ft-lb)

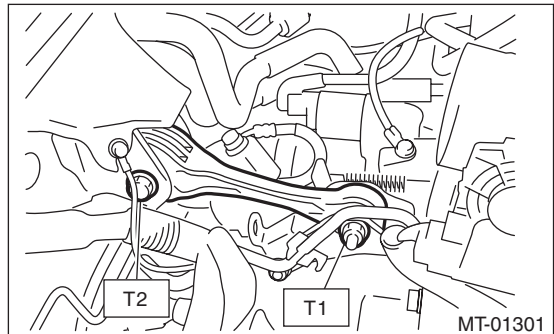

12) Install the clutch operating cylinder.

Tightening torque:

41 N·m (4.2 kgf-m, 30.2 ft-lb)

NOTE:

Check that the clutch hose is routed properly.

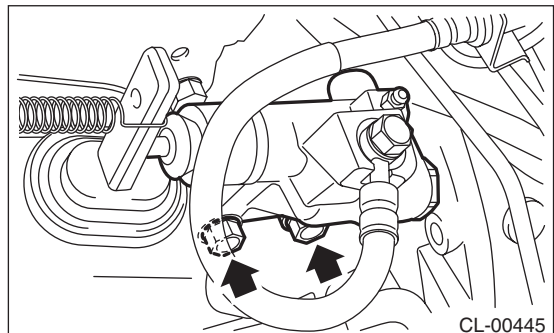

Manual Transmission Assembly

Brought to you by Eris Studios
NOT FOR RESALE

MANUAL TRANSMISSION AND DIFFERENTIAL

13) Install the starter assembly. <Ref. to SC(STI)-5, INSTALLATION, Starter.>

14) Attach the ground cable to the transmission and body.

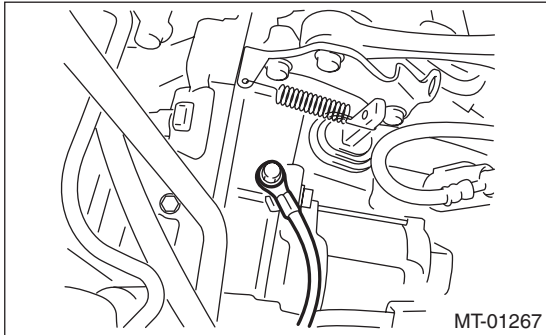
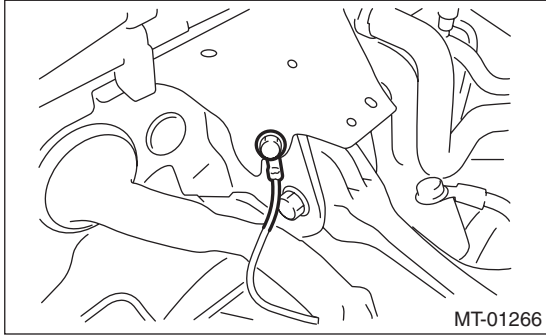

15) Install the secondary air combination valve. <Ref. to EC(STI)-24, SECONDARY AIR COMBINATION VALVE LH, INSTALLATION, Secondary Air Combination Valve.>

16) Connect the following harness connectors, then attach the engine hanger rear.

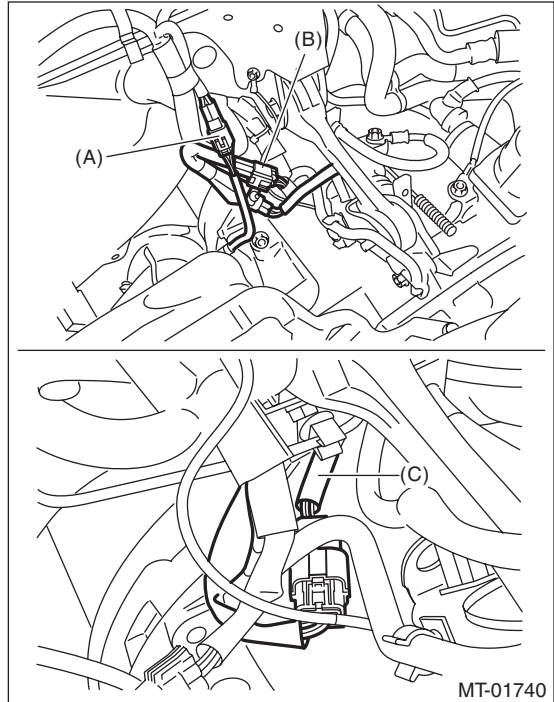

- (A) Front oxygen (A/F) sensor connector
- (B) Rear oxygen sensor connector
- (C) Neutral position switch backup light switch connector

17) Set the ST to side retainer.

ST 28399SA010 OIL SEAL PROTECTOR

18) Install the front drive shaft into the transmission.

NOTE:

Replace the circlip of drive shaft with a new part.

19) Install the front drive shaft into transmission, remove the ST and insert the drive shaft securely.

ST 28399SA010 OIL SEAL PROTECTOR

20) Install the ball joint of the front arm.

Tightening torque:

50 N·m (5.1 kgf-m, 36.9 ft-lb)

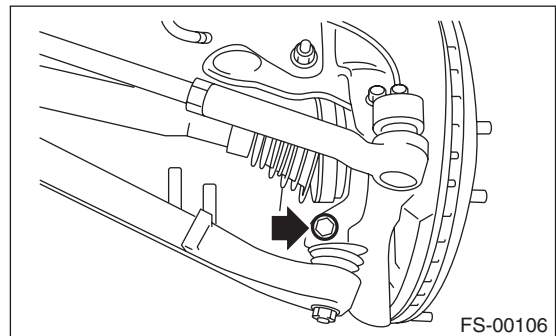

Brought to you by
Chris Studios
NOT FOR SALE

21) Install the front stabilizer link.

Tightening torque:

45 N·m (4.6 kgf·m, 33.2 ft·lb)

NOTE:

Use a new self-locking nut.

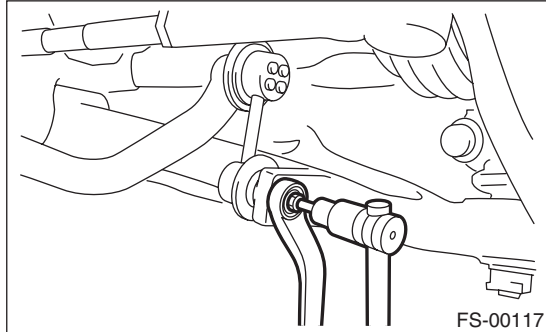

22) Install the propeller shaft. <Ref. to DS-11, INSTALLATION, Propeller Shaft.>

23) Install the heat shield cover.

24) Install the rear exhaust pipe and muffler. <Ref. to EX(STI)-12, INSTALLATION, Rear Exhaust Pipe.>
<Ref. to EX(STI)-14, INSTALLATION, Muffler.>

25) Install the center exhaust pipe. <Ref. to EX(STI)-8, INSTALLATION, Center Exhaust Pipe.>

26) Fill the transmission gear oil. <Ref. to 6MT-27, REPLACEMENT, Transmission Gear Oil.>

27) Install the transmission under cover.

28) Install the intercooler. <Ref. to IN(STI)-12, INSTALLATION, Intercooler.>

29) Connect the battery ground cable to the battery.

Preparation for Overhaul

MANUAL TRANSMISSION AND DIFFERENTIAL

Brought to you by Eris Studios
NOT FOR RESALE

7. Preparation for Overhaul

A: PROCEDURE

1) Clean oil, grease, dirt and dust from the transmission.

2) Attach the transmission to ST.

ST 18632AA000 STAND ASSY

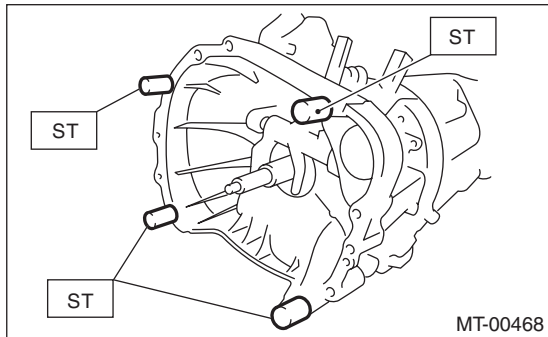

3) Apply oil to rotating parts before assembly.

4) When reusing disassembled parts, reinstall in the original positions and directions.

5) Gaskets, lock washers and lock nuts must be replaced with new parts.

6) Apply liquid gasket to the specified areas to prevent leakage.

Brought to you by
Chris Studios
NOT FOR SALE

8. Air Breather Hose

A: REMOVAL

Disconnect the air breather hose.

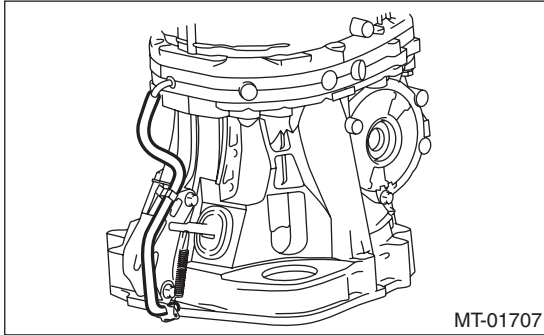

B: INSTALLATION

Connect the air breather hose.

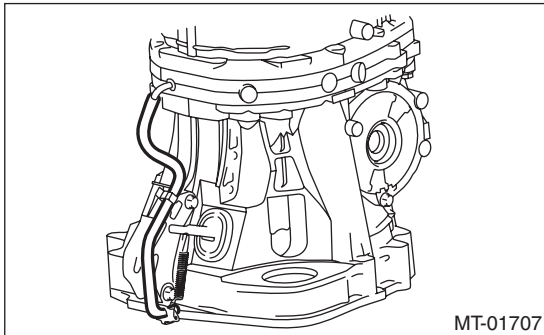

C: INSPECTION

Make sure the hose is not cracked or clogged.

Back-up Light Switch

MANUAL TRANSMISSION AND DIFFERENTIAL

Brought to you by Eris Studios
NOT FOR RESALE

9. Back-up Light Switch

A: REMOVAL

- 1) Remove the manual transmission assembly from the vehicle. <Ref. to 6MT-32, REMOVAL, Manual Transmission Assembly.>
- 2) Disconnect the back-up light switch connector.

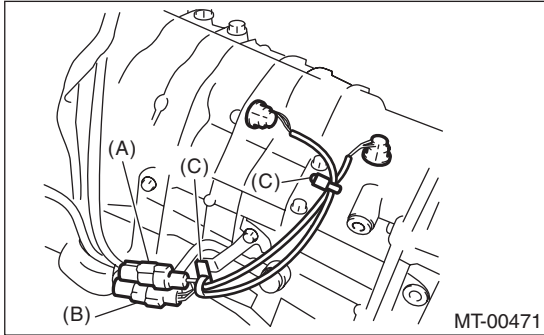

- (A) Back-up light switch connector (Gray)
- (B) Neutral position switch connector (Brown)
- (C) Clip

- 3) Disconnect the back-up light switch.

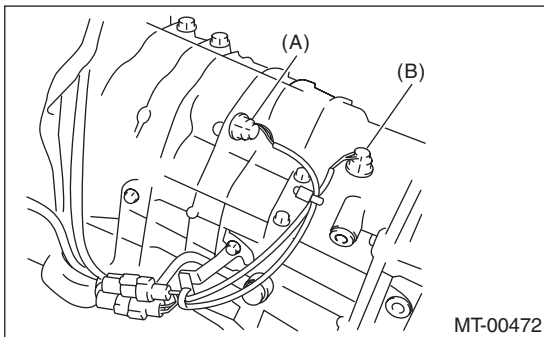

- (A) Back-up light switch
- (B) Neutral position switch

B: INSTALLATION

- 1) Install the back-up light switch.

NOTE:

Use a new gasket.

Tightening torque:

32 N·m (3.3 kgf·m, 23.6 ft·lb)

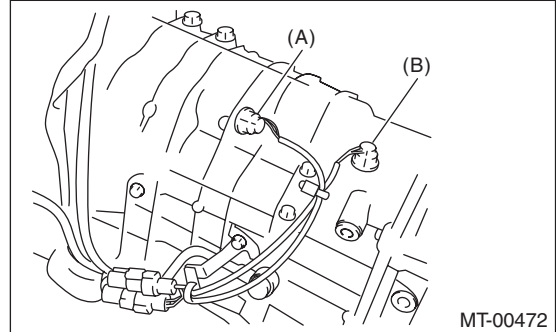

- (A) Back-up light switch
- (B) Neutral position switch

- 2) Connect the back-up light switch connector.

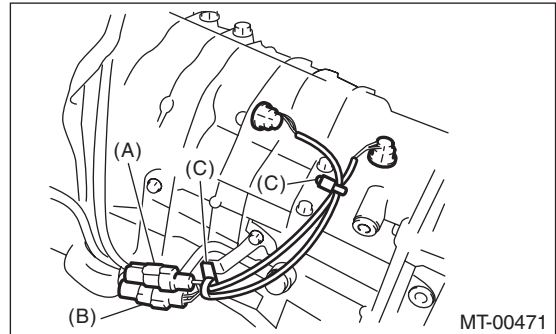

- (A) Back-up light switch connector (Gray)
- (B) Neutral position switch connector (Brown)
- (C) Clip

- 3) Install the manual transmission assembly to the vehicle. <Ref. to 6MT-34, INSTALLATION, Manual Transmission Assembly.>

C: INSPECTION

- 1) Disconnect the ground cable from the battery.
- 2) Remove the intercooler. <Ref. to IN(STI)-11, REMOVAL, Intercooler.>
- 3) Disconnect the transmission harness and chassis harness.

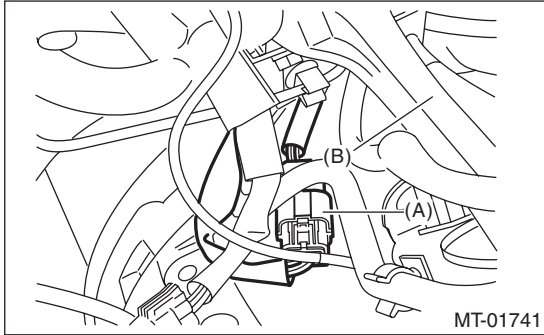

- (A) Transmission connector
- (B) Pitching stopper

- 4) Measure the resistance between the back-up light switch terminals. If it is not within the specification, replace the back-up light switch.

Gear shift position	Terminal No.	Specification
Back position	3 and 6	Less than 1 Ω
Other positions		1 M Ω or more

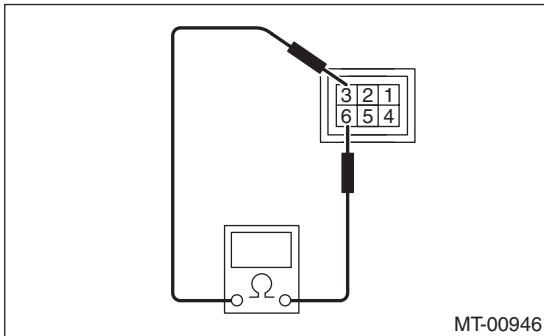

Neutral Position Switch

MANUAL TRANSMISSION AND DIFFERENTIAL

Brought to you by Eris Studios
NOT FOR RESALE

10. Neutral Position Switch

A: REMOVAL

- 1) Remove the manual transmission assembly from the vehicle. <Ref. to 6MT-32, REMOVAL, Manual Transmission Assembly.>
- 2) Disconnect the connector and clip of the neutral position switch.

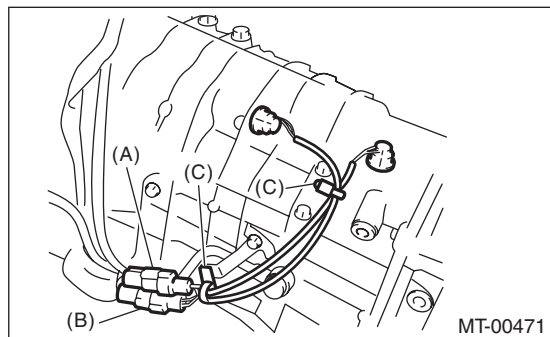

- (A) Back-up light switch connector (Gray)
- (B) Neutral position switch connector (Brown)
- (C) Clip

- 3) Remove the neutral position switch.

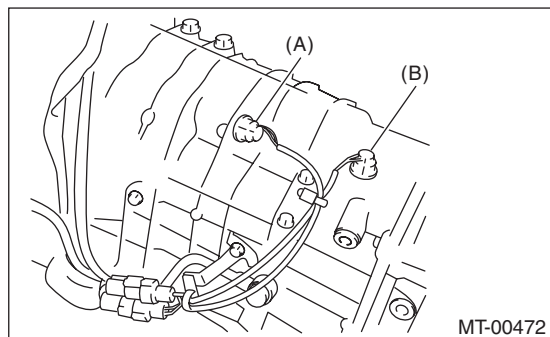

- (A) Back-up light switch
- (B) Neutral position switch

B: INSTALLATION

- 1) Install the neutral position switch.

NOTE:

Use a new gasket.

Tightening torque:

32 N·m (3.3 kgf-m, 23.6 ft-lb)

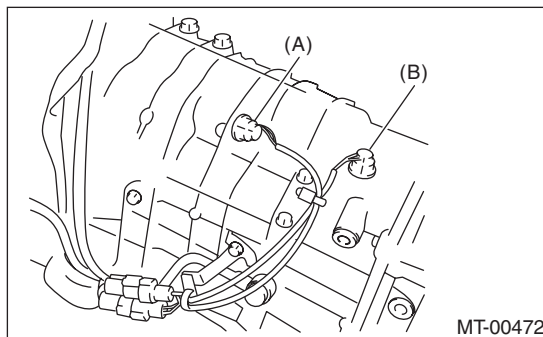

- (A) Back-up light switch
- (B) Neutral position switch

- 2) Connect the connector and clip of the neutral position switch.

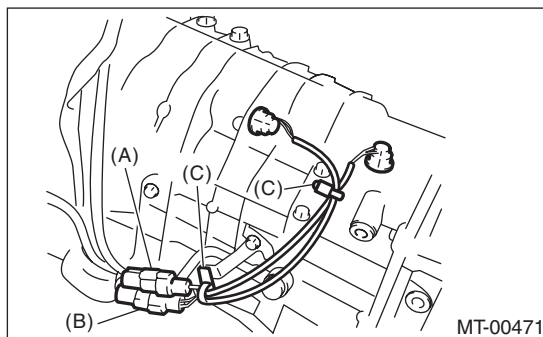

- (A) Back-up light switch connector (Gray)
- (B) Neutral position switch connector (Brown)
- (C) Clip

- 3) Install the manual transmission assembly to the vehicle. <Ref. to 6MT-34, INSTALLATION, Manual Transmission Assembly.>

C: INSPECTION

- 1) Disconnect the ground cable from the battery.
- 2) Remove the intercooler. <Ref. to IN(STI)-11, REMOVAL, Intercooler.>
- 3) Disconnect the transmission harness and chassis harness.

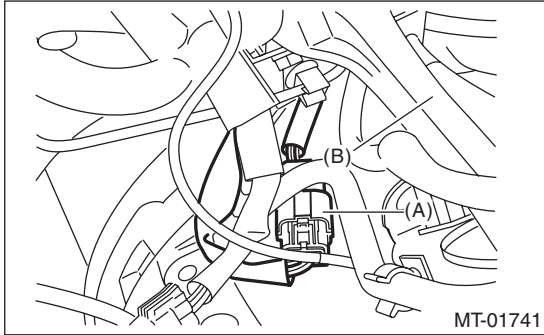

- (A) Transmission connector
- (B) Pitching stopper

- 4) Measure the resistance between neutral position switch terminals. If not within the standard values, replace the neutral position switch.

Gear shift position	Terminal No.	Specification
Neutral position	2 and 5	Less than 1 Ω
Other positions		1 M Ω or more

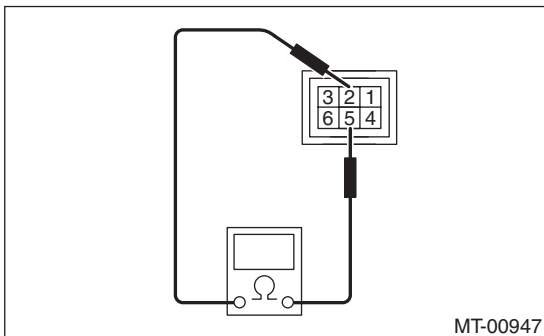

11.Extension Case

A: REMOVAL

- 1) Remove the manual transmission assembly from the vehicle. <Ref. to 6MT-32, REMOVAL, Manual Transmission Assembly.>
- 2) Prepare the transmission for overhaul. <Ref. to 6MT-38, Preparation for Overhaul.>
- 3) Remove the extension case.

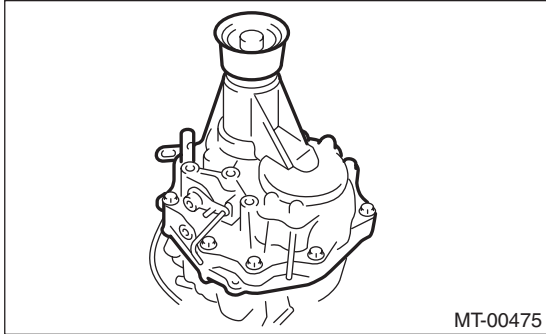

- 4) Remove any remaining liquid gasket from the extension case and transmission case.

B: INSTALLATION

- 1) Select the thrust washer of the transfer driven gear, and attach to the extension case. <Ref. to 6MT-47, ADJUSTMENT, Extension Case.>
- 2) Apply a thin coat of oil to the outer surface of the bearing cone, and attach to the extension case.
- 3) Select the thrust washer of the transfer drive gear, and attach to the center differential.
- 4) Apply liquid gasket to the transmission case.

Liquid gasket:

THREE BOND 1215 (Part No. 004403007) or equivalent

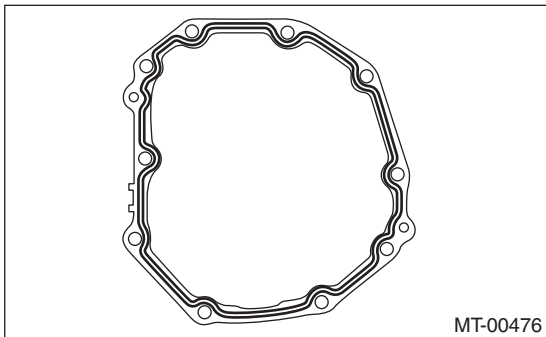

- 5) Install the extension case.

Tightening torque:

48 N·m (4.9 kgf·m, 35.4 ft·lb)

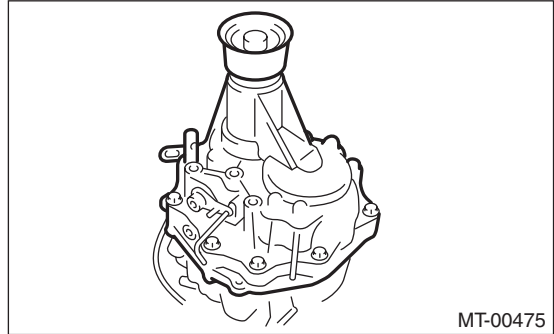

NOTE:

Insert the stopper section of the center differential between the oil guide.

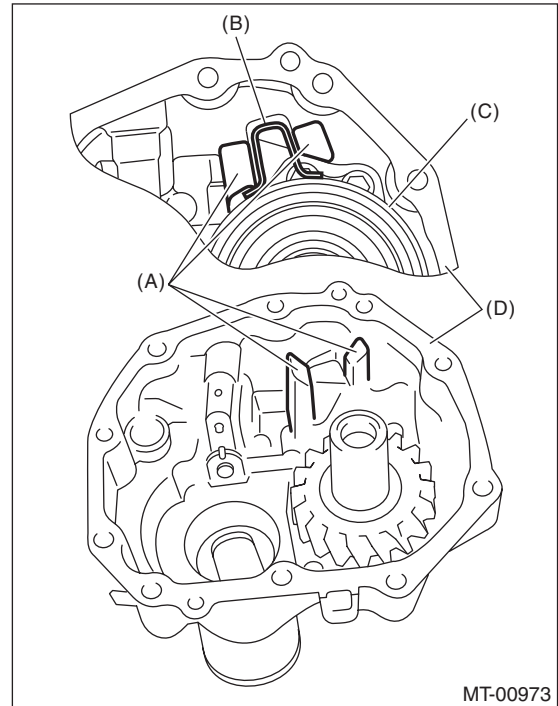

- (A) Oil guide
- (B) Stopper
- (C) Center differential
- (D) Extension Case

- 6) Install the manual transmission assembly to the vehicle. <Ref. to 6MT-34, INSTALLATION, Manual Transmission Assembly.>

Extension Case

MANUAL TRANSMISSION AND DIFFERENTIAL

Brought to you by
NOVA
SALES
Meris Studios

C: DISASSEMBLY

- 1) Remove the transfer drive gear. <Ref. to 6MT-54, REMOVAL, Transfer Drive Gear.>
- 2) Remove the oil guide.

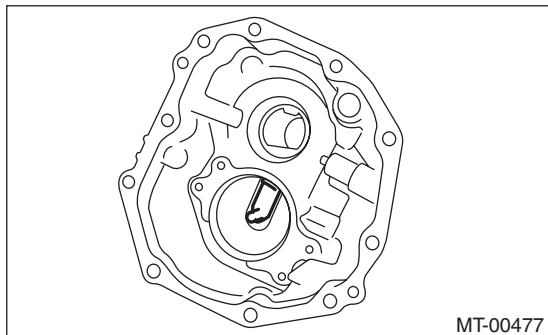

- 3) Remove the shift bracket.

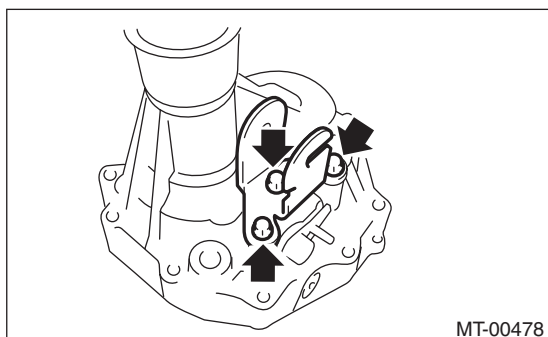

- 4) Remove the bearing cone using the ST.
ST 18758AA000 PULLER

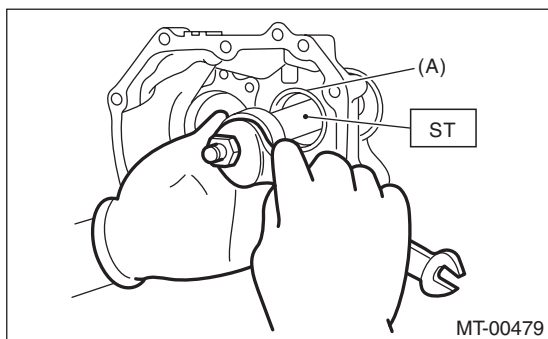

(A) Bearing cone

- 5) Remove the thrust washer and oil plate.

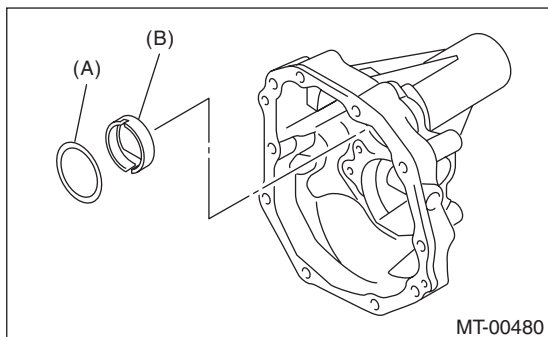

(A) Thrust washer
(B) Oil plate

- 6) Remove the shifter arm oil seal.

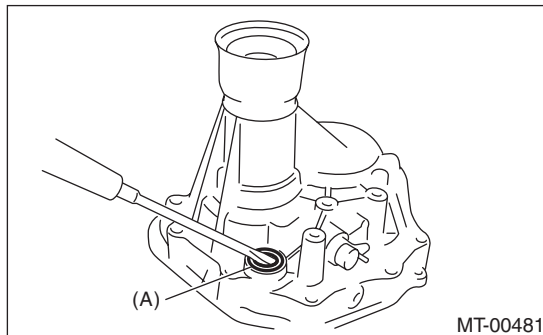

(A) Oil seal

- 7) Remove the reverse check system. <Ref. to 6MT-51, REMOVAL, Reverse Check System.>
- 8) Remove the extension oil seal. <Ref. to 6MT-28, REPLACEMENT, Oil Seal.>

Extension Case

MANUAL TRANSMISSION AND DIFFERENTIAL

Brought to you by Eris Studios
NOT FOR RESALE

D: ASSEMBLY

- 1) Install the reverse check system. <Ref. to 6MT-52, INSTALLATION, Reverse Check System.>
- 2) Install the extension case oil seal. <Ref. to 6MT-28, REPLACEMENT, Oil Seal.>
- 3) Install a shifter arm oil seal using the ST.

ST1 18657AA000 INSTALLER
ST2 18671AA000 OIL SEAL GUIDE

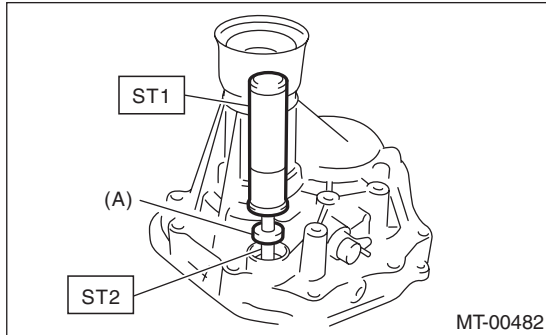

(A) Oil seal

- 4) Install the oil plate.

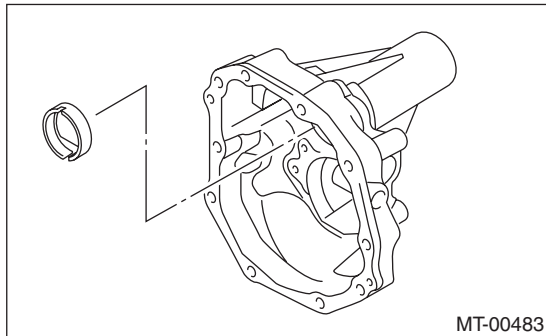

- 5) Select the thrust washer of the bearing, and attach to the extension case. <Ref. to 6MT-47, ADJUSTMENT, Extension Case.>
- 6) Apply a thin coat of oil to the outer surface of the bearing cone, and attach to the extension case.
- 7) Install the shift bracket.

Tightening torque:

25 N·m (2.5 kgf·m, 18.4 ft·lb)

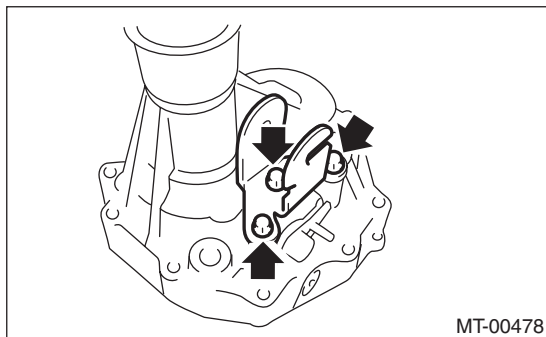

- 8) Attach the oil guide and the transfer driven gear. <Ref. to 6MT-54, INSTALLATION, Transfer Drive Gear.>

E: INSPECTION

- 1) Check to make sure there is no damage or cracks on the extension case. If damage or cracking is found, replace the extension case.
- 2) Inspect for oil leaks at the extension case and transmission case oil seals and mating surfaces. If there are oil leaks, replace the oil seal and liquid gasket.

Brought to you by
NOVA
SALES
Brought to you by
Peris Studios

F: ADJUSTMENT

1. TRANSFER DRIVEN GEAR BEARING THRUST WASHER ADJUSTMENT

1) Remove the bearing cone from the extension case using the ST.

ST 18758AA000 PULLER

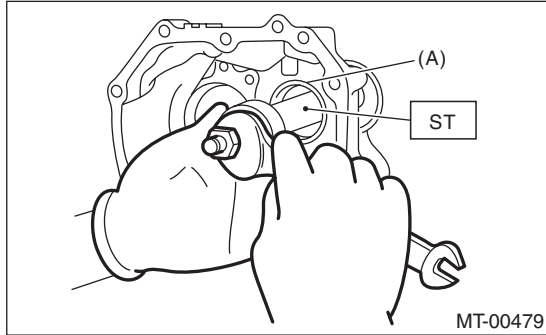

(A) Bearing cone

2) Remove the thrust washer.

3) Measure depth "Z" between the extension case end area and bearing cone contact area.

ST 398643600 GAUGE

NOTE:

When measuring depth "Z", subtract the thickness of the ST [15 mm (0.59 in)] from the measured value.

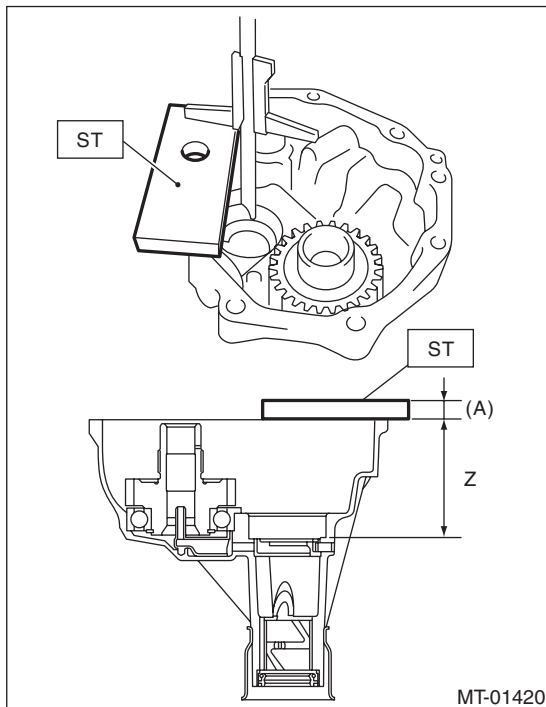

(A) 15 mm (0.59 in)

4) Remove the transfer driven gear. <Ref. to 6MT-56, REMOVAL, Transfer Driven Gear.>

5) Remove the center differential. <Ref. to 6MT-58, REMOVAL, Center Differential.>

6) Remove the oil guides G and H.

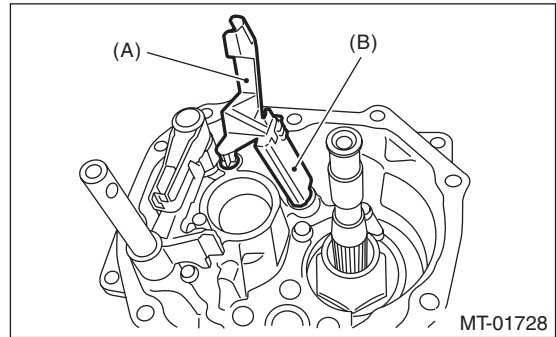

(A) Oil guide G

(B) Oil guide H

7) Remove the snap ring and flat washer from the selector arm area.

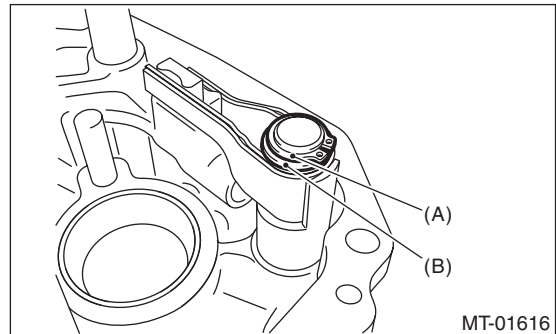

(A) Snap ring

(B) Flat washer

8) Using an ST, remove the neutral set spring and support.

ST1 18756AA000 CLAW

ST2 399893600 PLIER

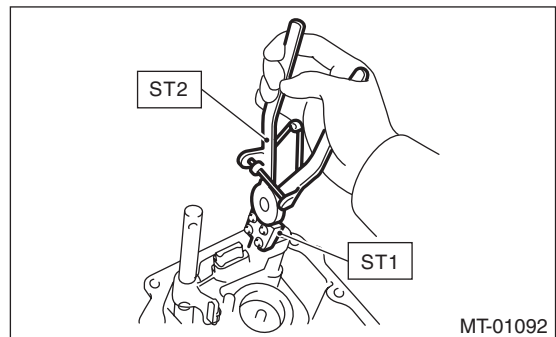

Extension Case

MANUAL TRANSMISSION AND DIFFERENTIAL

Brought to you by Eris Studios
NOT FOR RESALE

9) Lift the striking rod, and remove the spring pin.

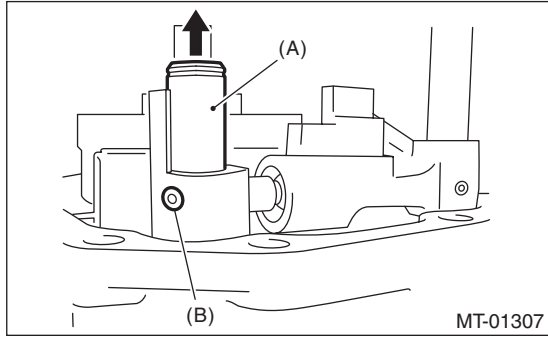

- (A) Striking rod
- (B) Spring pin

10) Remove the selector arm No. 2 and the shifter arm.

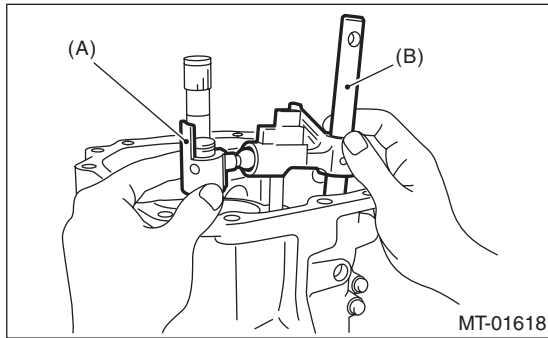

- (A) Selector arm No. 2
- (B) Shifter arm

11) Attach the bearing cone to the transfer driven gear.

12) Set the ST.
ST 18831AA000 GAUGE

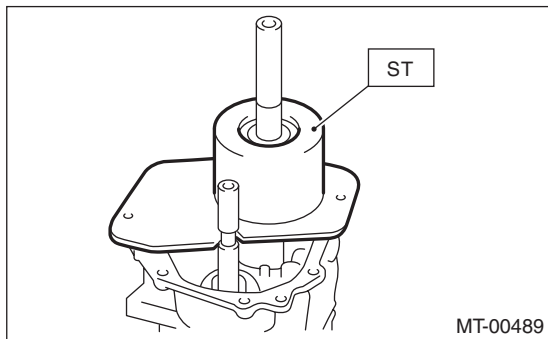

13) Turn the transfer driven gear 10 or more times to seat the bearing properly.

14) Measure depth "Y" between the end of the ST and the bearing cone.

ST 18831AA000 GAUGE

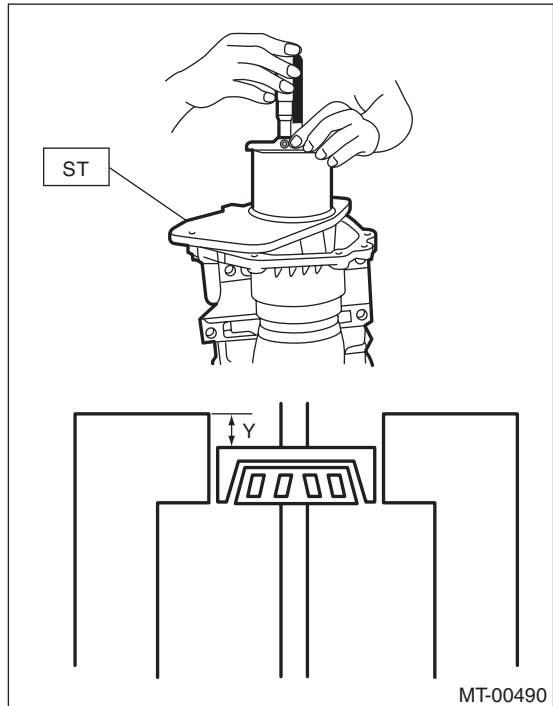

15) Using the following calculation, calculate the transfer driven gear bearing thrust washer value "t".
 $t = Z - (100 - Y) - \{0.02 - 0.11 \text{ mm} (0.0008 - 0.0043 \text{ in})\}$

t mm (in)	Transfer driven gear bearing thrust washer thickness
Y mm (in)	Depth between the end of the ST and the bearing cone.
Z mm (in)	Depth between the end of the extension case and the bearing cone contact area.
0.02 — 0.11 mm (0.0008 — 0.0043 in)	Standard clearance between the thrust washer and taper roller bearing
100 mm (3.94 in)	Height of ST

Extension Case

MANUAL TRANSMISSION AND DIFFERENTIAL

Brought to you by
 NOVA
 SALE
 Brought to you by
 Novus Studios

16) Refer to the calculated value "t" to select the closest thrust washer from the following table.

Standard clearance between the thrust washer and taper roller bearing

0.02 — 0.11 mm (0.0008 — 0.0043 in)

NOTE:

Match to be within the standard clearance range.

Thrust washer (50 × 61 × t)	
Part No.	Thickness t mm (in)
803050060	0.50 (0.0197)
803050061	0.55 (0.0217)
803050062	0.60 (0.0236)
803050063	0.65 (0.0256)
803050064	0.70 (0.0276)
803050065	0.75 (0.0295)
803050066	0.80 (0.0315)
803050067	0.85 (0.0335)
803050068	0.90 (0.0354)
803050069	0.95 (0.0374)
803050070	1.00 (0.0394)
803050071	1.05 (0.0413)
803050072	1.10 (0.0433)
803050073	1.15 (0.0453)
803050074	1.20 (0.0472)
803050075	1.25 (0.0492)
803050076	1.30 (0.0512)
803050077	1.35 (0.0531)
803050078	1.40 (0.0551)
803050079	1.45 (0.0570)

19) Using the ST, install the neutral set spring and support.

ST1 18756AA000 CLAW
 ST2 399893600 PLIER

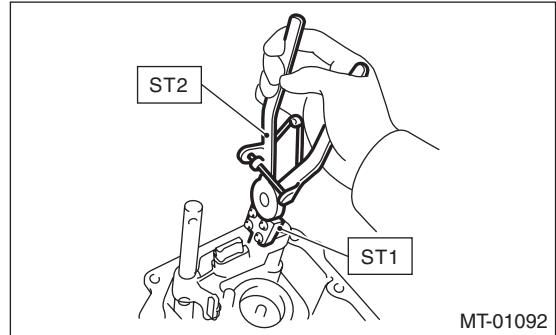

20) Install the flat washer and snap ring to the selector arm area.

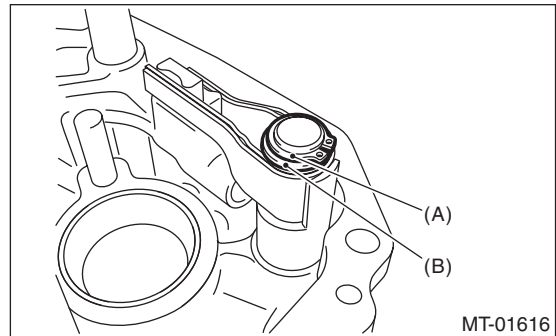

(A) Snap ring
 (B) Flat washer

17) Install the selector arm No. 2 and the shifter arm.

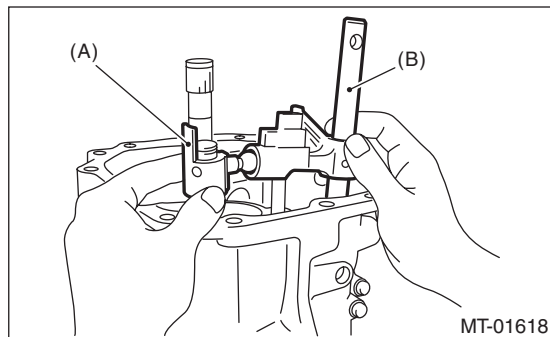

(A) Selector arm No. 2
 (B) Shifter arm

18) Install a new spring pin.

21) Install the center differential. <Ref. to 6MT-58, INSTALLATION, Center Differential.>

Extension Case

MANUAL TRANSMISSION AND DIFFERENTIAL

Brought to you by Eris Studios
NOT FOR RESALE

2. TRANSFER DRIVE GEAR THRUST WASHER SELECTION

1) Measure height “Z” between the transmission case end area and ST.

ST 398643600 GAUGE

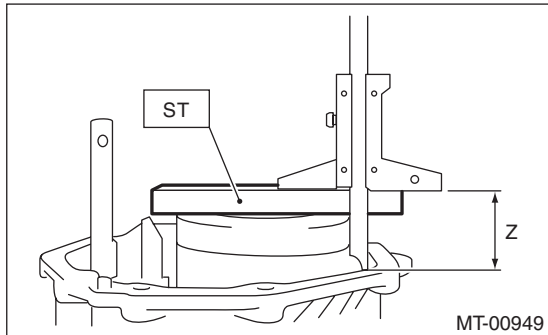

2) Measure depth “Y” between the end of the ST and the transfer drive gear.

ST 398643600 GAUGE

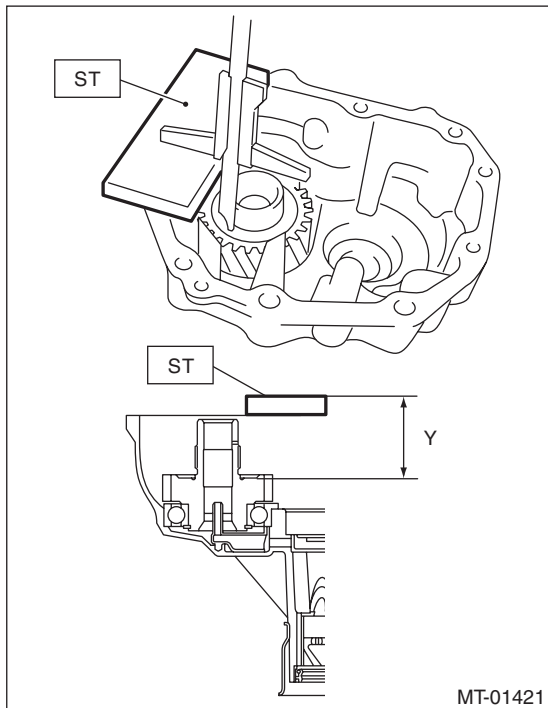

3) Using the following calculation, calculate the transfer drive gear thrust washer value “t”.

$$t = \{Y - 15 \text{ mm (0.59 in)}\} - \{Z - 15 \text{ mm (0.59 in)}\}$$

$$- 0.75 - 0.95 \text{ mm (0.030 - 0.037 in)}$$

t mm (in)	Transfer drive gear thrust washer thickness
Y mm (in)	Depth between the end of the ST and the transfer drive gear
Z mm (in)	Height from the end of the transmission case to the end of the ST.
0.75 — 0.95 mm (0.030 — 0.037 in)	Standard clearance between the thrust washer and transfer drive gear
15 mm (0.591 in)	Thickness of ST

4) Refer to the calculated value “t” to select the closest thrust washer from the following table.

Standard clearance between the thrust washer and transfer drive gear

0.75 — 0.95 mm (0.030 — 0.037 in)

NOTE:

Match to be within the standard clearance range.

Thrust washer (36.3 × 52 × t)	
Part No.	Thickness mm (in)
803036070	0.80 (0.0315)
803036071	0.95 (0.0374)
803036072	1.10 (0.0433)
803036073	1.25 (0.0492)
803036074	1.40 (0.0551)
803036075	0.65 (0.0256)

5) Install the selected thrust washer.

Reverse Check System

MANUAL TRANSMISSION AND DIFFERENTIAL

Brought to you by
NOT FOR SALE
Peris Studios

12. Reverse Check System

A: REMOVAL

- 1) Remove the manual transmission assembly from the vehicle. <Ref. to 6MT-32, REMOVAL, Manual Transmission Assembly.>
- 2) Prepare the transmission for overhaul. <Ref. to 6MT-38, Preparation for Overhaul.>
- 3) Remove the extension case. <Ref. to 6MT-44, REMOVAL, Extension Case.>
- 4) Remove the snap ring and washer from the reverse check shaft.

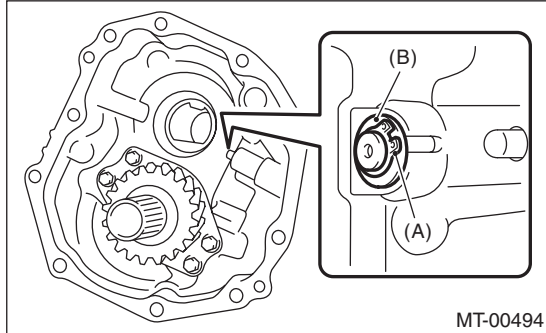

- (A) Snap ring
- (B) Washer

- 5) Remove the reverse check shaft and spring from the extension case.

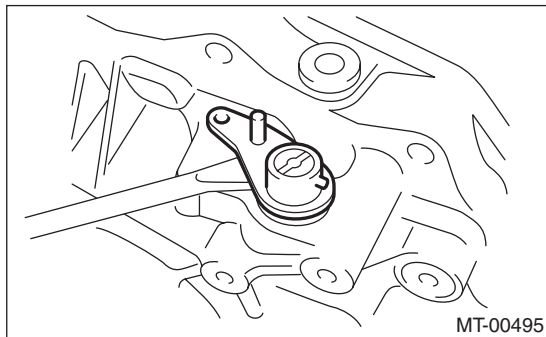

- 6) Remove the spring pin, and remove the reverse check lever and oil seal from the reverse check shaft.

NOTE:

Do not reuse the oil seal.

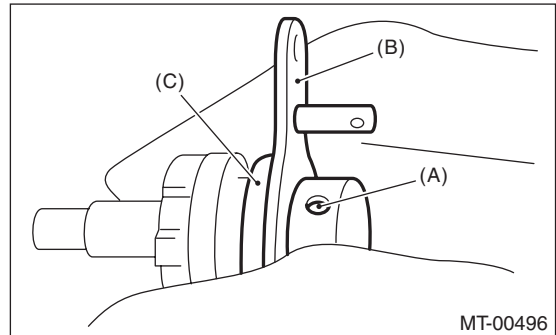

- (A) Spring pin
- (B) Reverse check lever
- (C) Oil seal

- 7) Remove the plug from the extension case, and remove the gasket, spring and plunger.

NOTE:

Do not reuse the gasket.

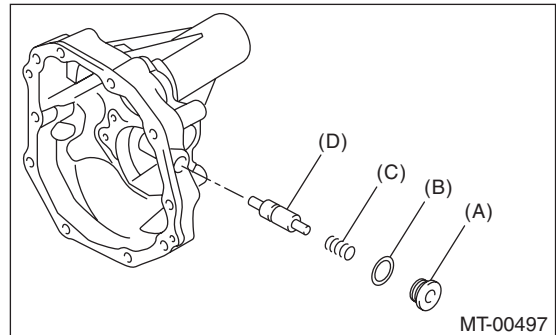

- (A) Plug
- (B) Gasket
- (C) Spring
- (D) Plunger

- 8) Remove the reverse lock plunger.

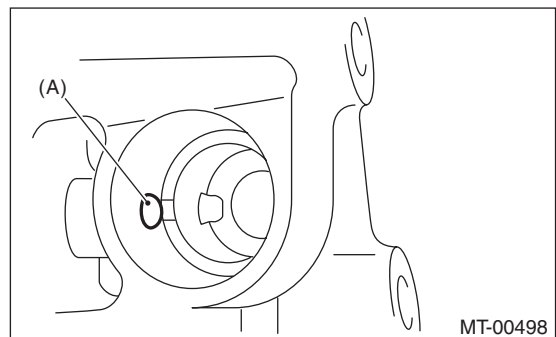

- (A) Reverse lock plunger

Reverse Check System

MANUAL TRANSMISSION AND DIFFERENTIAL

Brought to you by Eris Studios
NOT FOR RESALE

B: INSTALLATION

- 1) Insert the reverse lock plunger.
- 2) Install the reverse check plug, spring, gasket, and plug in order.

Tightening torque:

41 N·m (4.2 kgf-m, 30.2 ft-lb)

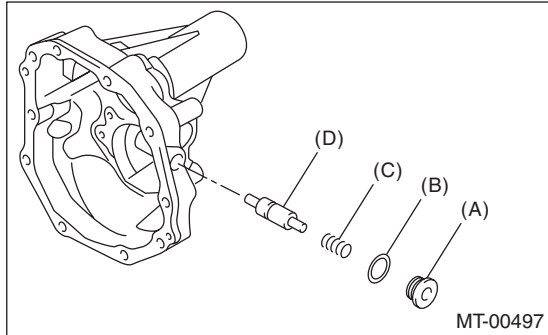

- (A) Plug
- (B) Gasket
- (C) Spring
- (D) Reverse check plug

- 3) Install the spring and reverse check shaft to the extension case.

NOTE:

Confirm that the end of the spring matches the hole of the reverse check shaft and the cut out of the extension case.

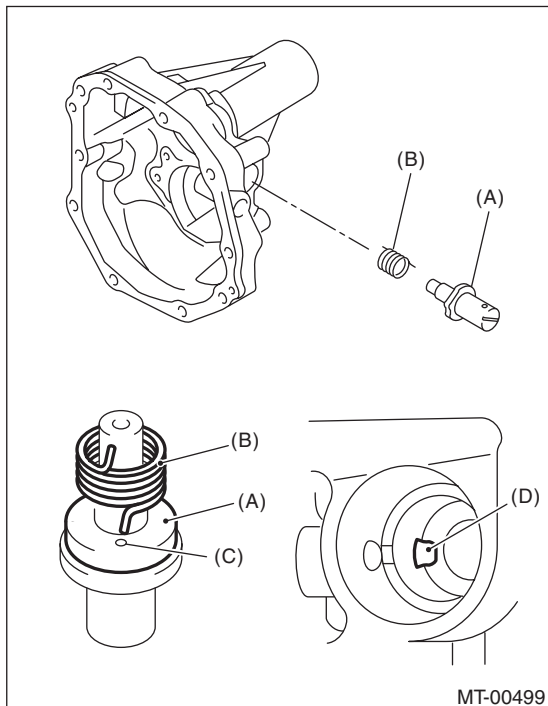

- (A) Reverse check shaft
- (B) Spring
- (C) Hole
- (D) Cut out

- 4) Install the washer and snap ring.

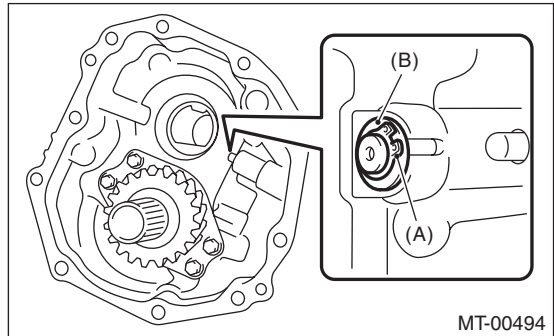

- (A) Snap ring
- (B) Washer

- 5) Attach ST1 to the reverse check shaft. Install the new oil seal, and push it in using ST2.

ST1 18671AA000 OIL SEAL GUIDE

ST2 18657AA010 INSTALLER

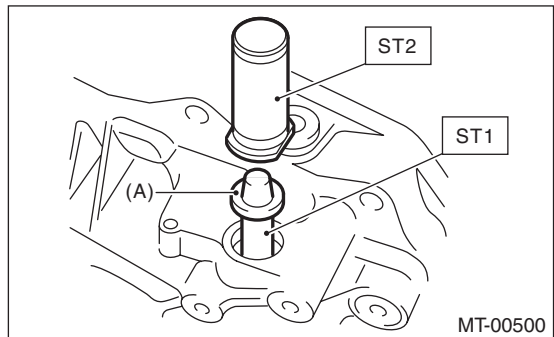

- (A) Oil seal

- 6) Insert the reverse check lever, and turn the reverse check shaft until the plunger is first pushed in.

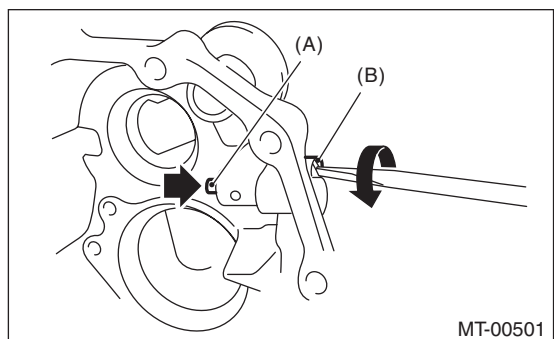

- (A) Plunger
- (B) Reverse check shaft

Reverse Check System

MANUAL TRANSMISSION AND DIFFERENTIAL

Brought to you by
NOVA Studios
NOT FOR SALE

7) Match the hole of the reverse check lever and the reverse check shaft, and attach the spring pin.

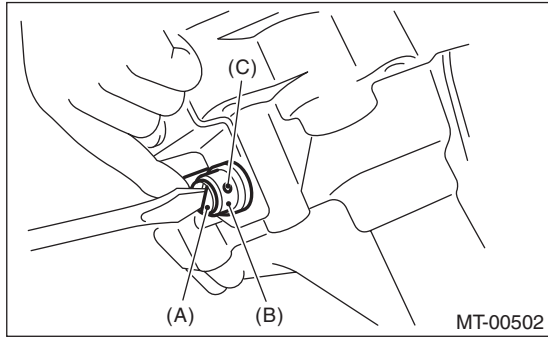

- (A) Reverse check shaft
- (B) Reverse check lever
- (C) Hole

8) Check that the reverse check is operating correctly. <Ref. to 6MT-53, INSPECTION, Reverse Check System.>

9) Install the extension case. <Ref. to 6MT-44, INSTALLATION, Extension Case.>

10) Install the manual transmission assembly to the vehicle. <Ref. to 6MT-34, INSTALLATION, Manual Transmission Assembly.>

C: INSPECTION

- 1) Check that there is no damage on any parts.
- 2) Check that the reverse check lever is operating smoothly.
- 3) Inspect that there is no oil leak at the oil seal section of the reverse check shaft. If there is oil leakage, replace the oil seal.
- 4) Check the operation of the reverse check.
 - (1) When the reverse check lever is in the following position, the plunger is pressed, or the gear can shift into reverse.

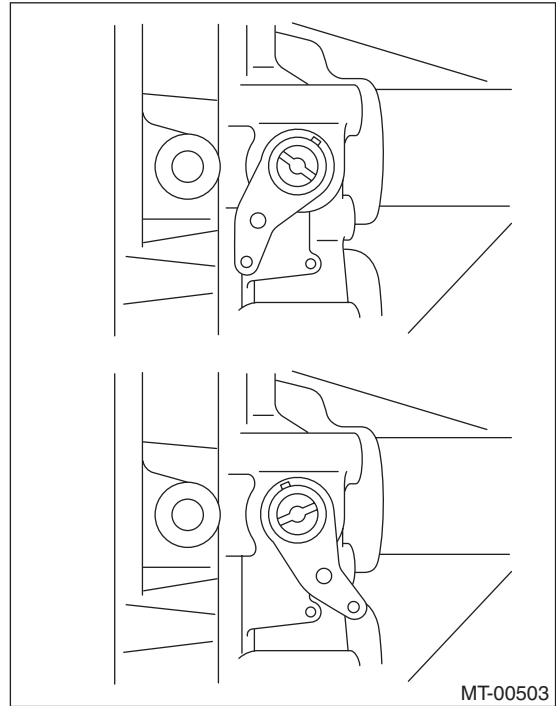

- (2) When the reverse check lever is in the following position, the plunger is not pressed, or the gear cannot shift into reverse.

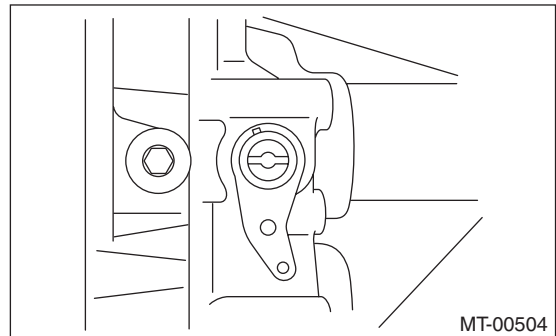

- 5) If not according to the standard, reassemble the reverse check system.

Transfer Drive Gear

MANUAL TRANSMISSION AND DIFFERENTIAL

Brought to you by Eris Studios
NOT FOR RESALE

13. Transfer Drive Gear

A: REMOVAL

- 1) Remove the manual transmission assembly from the vehicle. <Ref. to 6MT-32, REMOVAL, Manual Transmission Assembly.>
- 2) Prepare the transmission for overhaul. <Ref. to 6MT-38, Preparation for Overhaul.>
- 3) Remove the extension case. <Ref. to 6MT-44, REMOVAL, Extension Case.>
- 4) Remove the transfer drive gear.

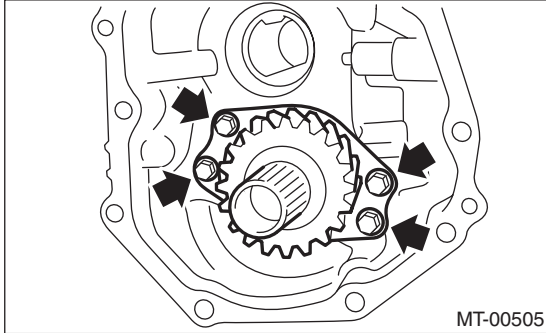

B: INSTALLATION

- 1) Install the transfer drive gear.

Tightening torque:

25 N·m (2.5 kgf-m, 18.4 ft-lb)

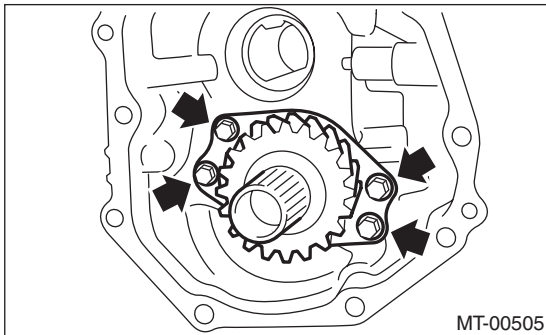

- 2) When the ball bearing, transfer drive gear or snap ring are replaced, select an appropriate thrust washer for the transfer drive gear. <Ref. to 6MT-46, ASSEMBLY, Extension Case.>
- 3) Install the extension case. <Ref. to 6MT-44, INSTALLATION, Extension Case.>
- 4) Install the manual transmission assembly to the vehicle. <Ref. to 6MT-34, INSTALLATION, Manual Transmission Assembly.>

C: DISASSEMBLY

- 1) Remove the snap ring.

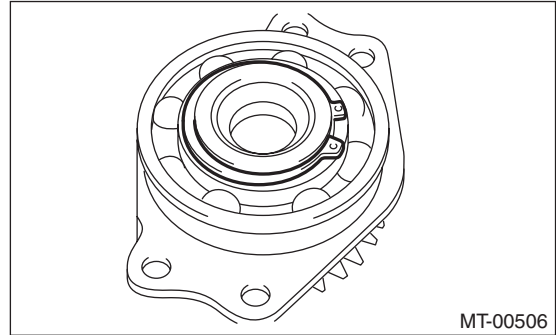

- 2) Remove the bearing using the ST.
ST 499877000 RACE 4-5 INSTALLER

NOTE:

Do not reuse the ball bearing.

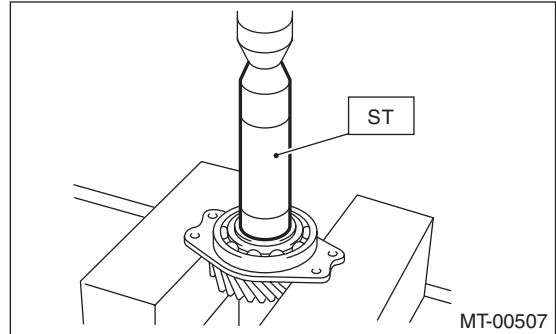

Transfer Drive Gear

MANUAL TRANSMISSION AND DIFFERENTIAL

Brought to you by
NOT FOR SALE
Peris Studios

D: ASSEMBLY

- 1) Using the ST, install the ball bearing.
ST1 499247400 INSTALLER
ST2 398497701 SEAT

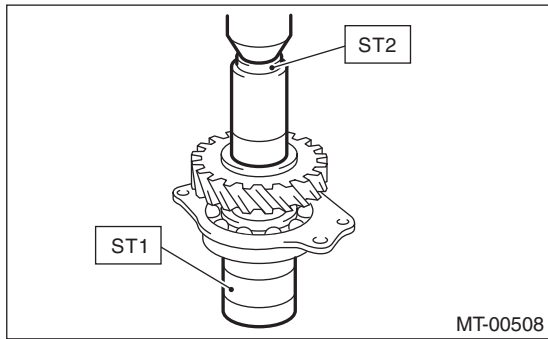

- 2) Install the snap ring.

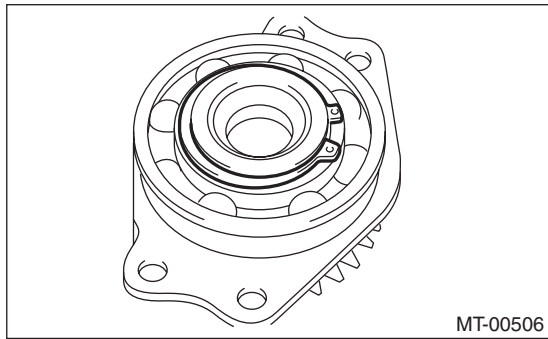

- 3) Inspect the clearance between the snap ring and the ball bearing. <Ref. to 6MT-55, INSPECTION, Transfer Drive Gear.>

E: INSPECTION

- 1) Bearing
Replace the bearings in the following cases.
 - Damage or rust on the bearings
 - Wear, or damage
 - The bearing does not rotate smoothly or an abnormal noise is emitted.
- 2) Drive gear
Replace the drive gear in following case:
 - If the drive gear tooth surface and shaft are excessively damaged or broken.
- 3) Measure the clearance between the snap ring and ball bearing inner race with a thickness gauge.

Standard clearance between the snap ring and inner race:

0 — 0.15 mm (0 — 0.0059 in)

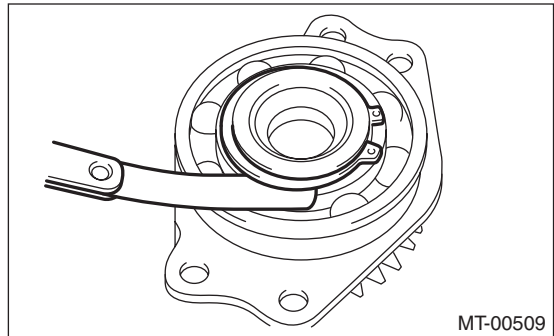

- 4) If the measurement is out of specifications, reselect an appropriate snap ring.

Thrust washer	
Part No.	Thickness mm (in)
805045050	1.76 (0.069)
805045060	1.88 (0.074)
805045070	2.00 (0.079)

After replacing the snap ring, reinspect the clearance.

Transfer Driven Gear

MANUAL TRANSMISSION AND DIFFERENTIAL

Brought to you by Eris Studios
NOT FOR RESALE

14. Transfer Driven Gear

A: REMOVAL

- 1) Remove the manual transmission assembly from the vehicle. <Ref. to 6MT-32, REMOVAL, Manual Transmission Assembly.>
- 2) Prepare the transmission for overhaul. <Ref. to 6MT-38, Preparation for Overhaul.>
- 3) Remove the extension case. <Ref. to 6MT-44, REMOVAL, Extension Case.>
- 4) Remove the transfer driven gear.

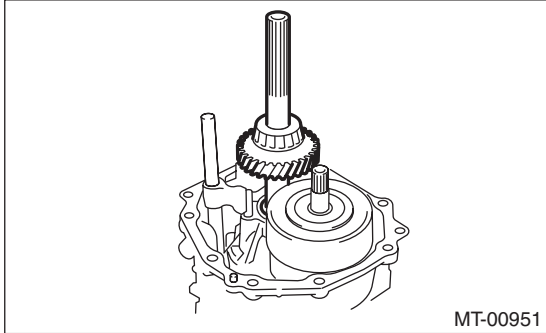

B: INSTALLATION

- 1) Install the transfer driven gear.

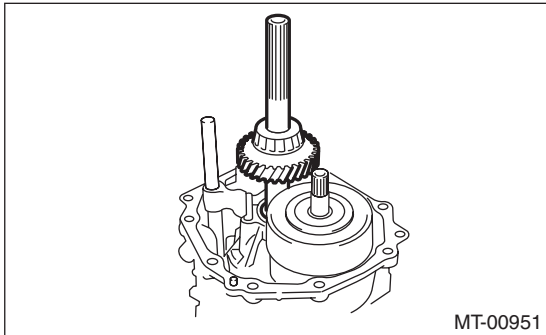

- 2) When the bearing or the transfer driven gear is replaced, select an appropriate thrust washer for the transfer driven gear. <Ref. to 6MT-47, ADJUSTMENT, Extension Case.>
- 3) Install the extension case. <Ref. to 6MT-44, INSTALLATION, Extension Case.>
- 4) Install the manual transmission assembly to the vehicle. <Ref. to 6MT-34, INSTALLATION, Manual Transmission Assembly.>

C: DISASSEMBLY

- 1) Using the ST, remove the roller bearing (extension case side).

ST 498515700 REMOVER

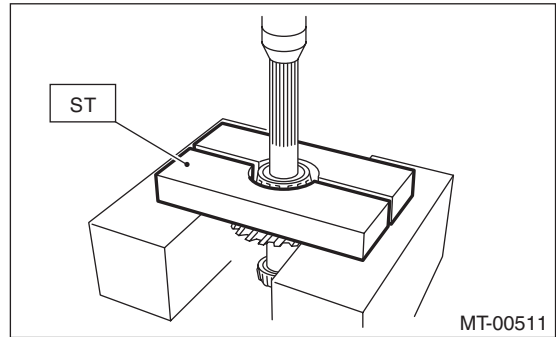

- 2) Using the ST, remove the roller bearing (transmission case side).

ST1 899858600 REMOVER

ST2 899864100 REMOVER

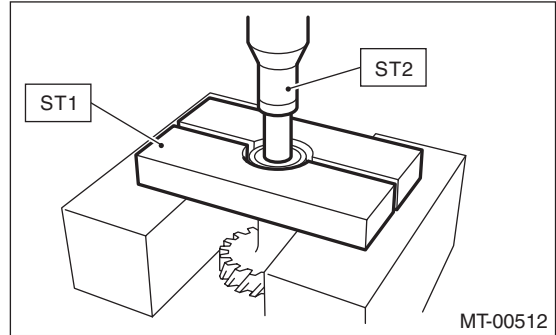

Brought to you by
NOT FOR SALE
Peris Studios

D: ASSEMBLY

1) Using the ST, install the roller bearing (extension case side).

ST1 398177700 INSTALLER

ST2 899864100 REMOVER

CAUTION:

Do not apply pressure in excess of 10 kN (1 ton, 1.1 US ton, 1.0 Imp ton).

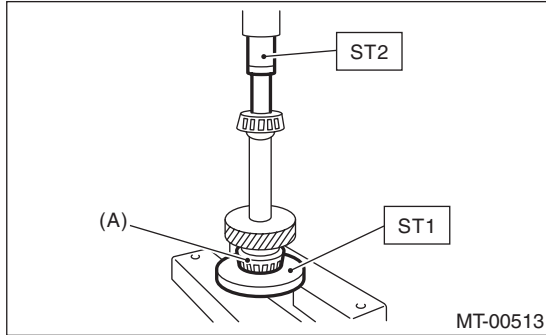

(A) Roller bearing

2) Using the ST, install the roller bearing (transmission case side).

ST 499757002 INSTALLER

CAUTION:

Do not apply pressure in excess of 10 kN (1 ton, 1.1 US ton, 1.0 Imp ton).

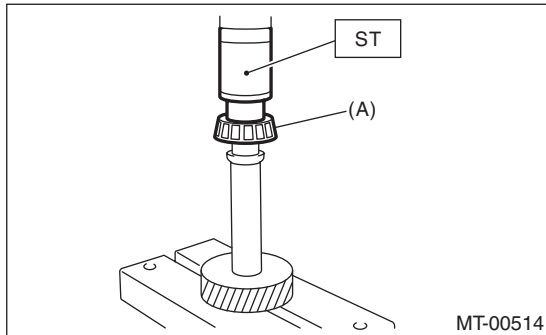

(A) Roller bearing

E: INSPECTION

1) Bearing

Replace the bearings in the following cases.

- Damage or rust on the bearings
- Wear, or damage
- After applying transmission gear oil, bearing does not rotate smoothly or an abnormal noise is emitted.

2) Driven gear

Replace the driven gear in the following cases.

- If the driven gear tooth surface and shaft are excessively damaged or broken.

Center Differential

MANUAL TRANSMISSION AND DIFFERENTIAL

Brought to you by Eris Studios
NOT FOR RESALE

15.Center Differential

A: REMOVAL

- 1) Remove the manual transmission case from the vehicle. <Ref. to 6MT-32, REMOVAL, Manual Transmission Assembly.>
- 2) Prepare the transmission for overhaul. <Ref. to 6MT-38, Preparation for Overhaul.>
- 3) Remove the extension case. <Ref. to 6MT-44, REMOVAL, Extension Case.>
- 4) Remove the transfer driven gear. <Ref. to 6MT-56, REMOVAL, Transfer Driven Gear.>
- 5) Disconnect the center differential connector.
- 6) Remove the thrust washer and center differential.

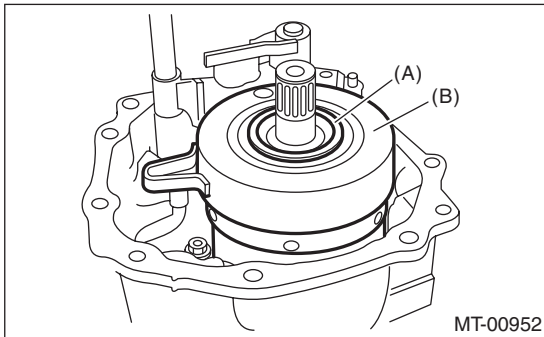

- (A) Thrust washer
- (B) Center differential

- 7) Remove the needle bearing.

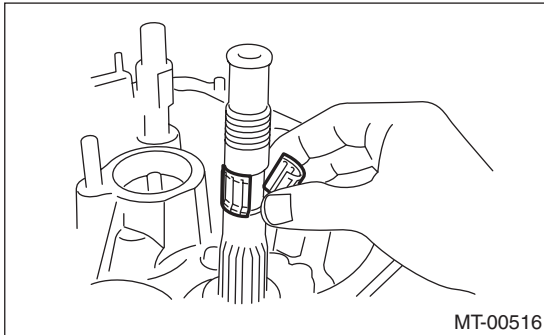

B: INSTALLATION

- 1) Install the needle bearing.

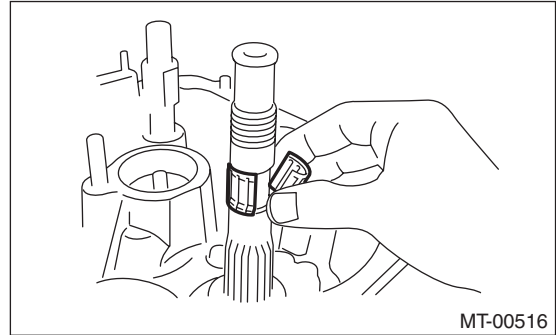

- 2) Install the thrust washer and center differential.

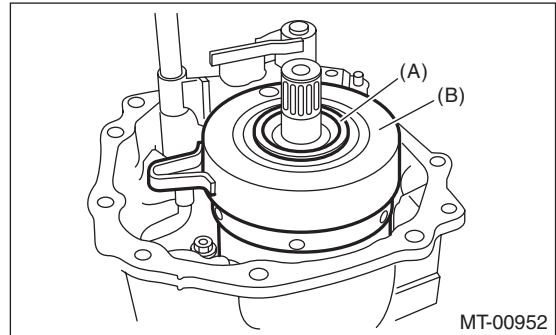

- (A) Thrust washer
- (B) Center differential

- 3) When replacing the center differential, select and install the appropriate transfer drive gear and thrust washer. <Ref. to 6MT-47, ADJUSTMENT, Extension Case.>
- 4) Connect the center differential connector, and affix to the oil guide.
- 5) Install the transfer driven gear. <Ref. to 6MT-56, INSTALLATION, Transfer Driven Gear.>
- 6) Install the extension case. <Ref. to 6MT-44, INSTALLATION, Extension Case.>
- 7) Install the manual transmission case assembly to the vehicle. <Ref. to 6MT-34, INSTALLATION, Manual Transmission Assembly.>

C: INSPECTION

Check that there is no damage on the center differential. Replace if damaged.

Brought to you by
NOVA
SALES
Meris Studios

16. Transmission Case

A: REMOVAL

- 1) Remove the manual transmission assembly from the vehicle. <Ref. to 6MT-32, REMOVAL, Manual Transmission Assembly.>
- 2) Prepare the transmission for overhaul. <Ref. to 6MT-38, Preparation for Overhaul.>
- 3) Remove the neutral position switch, back-up light switch and harness. <Ref. to 6MT-42, REMOVAL, Neutral Position Switch.> <Ref. to 6MT-40, REMOVAL, Back-up Light Switch.>
- 4) Remove the extension case. <Ref. to 6MT-44, REMOVAL, Extension Case.>
- 5) Remove the transfer driven gear. <Ref. to 6MT-56, REMOVAL, Transfer Driven Gear.>
- 6) Remove the center differential. <Ref. to 6MT-58, REMOVAL, Center Differential.>
- 7) Remove the oil guides G and H.

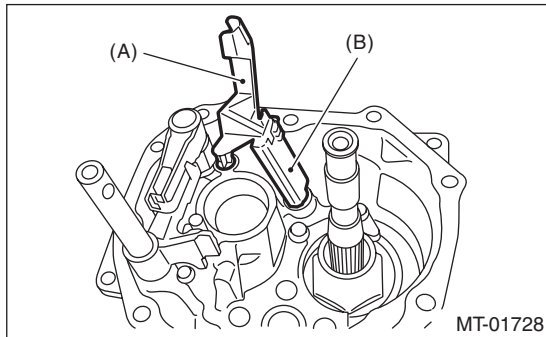

- (A) Oil guide G
- (B) Oil guide H

- 8) Remove the snap ring and flat washer from the selector arm area.

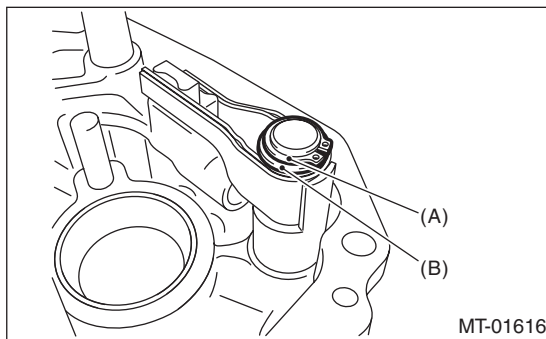

- (A) Snap ring
- (B) Flat washer

- 9) Using an ST, remove the neutral set spring and support.

- ST1 18756AA000 CLAW
- ST2 399893600 PLIER

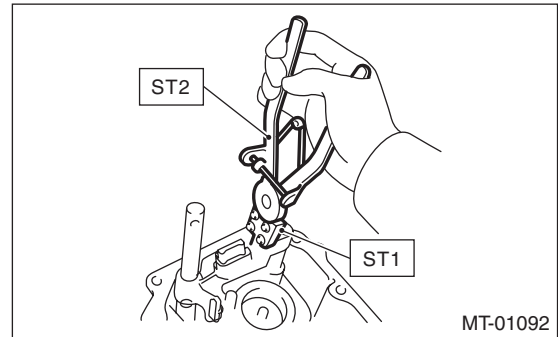

- 10) Lift the striking rod, and remove the spring pin.

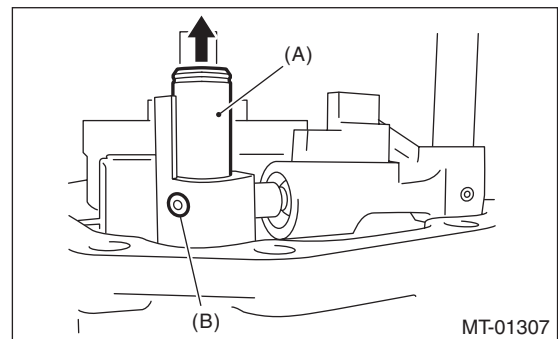

- (A) Striking rod
- (B) Spring pin

- 11) Remove the selector arm No. 2 and the shifter arm.

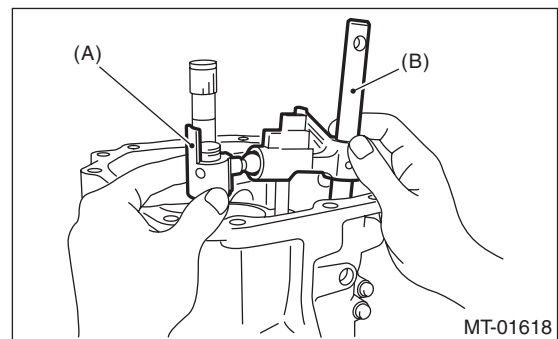

- (A) Selector arm No. 2
- (B) Shifter arm

Transmission Case

MANUAL TRANSMISSION AND DIFFERENTIAL

Brought to you by Eris Studios
NOT FOR RESALE

12) Remove the transfer bearing holder.

NOTE:

Using a general tool may cause damage. Remove the bolt using the ST.

ST 18663AA000 SOCKET

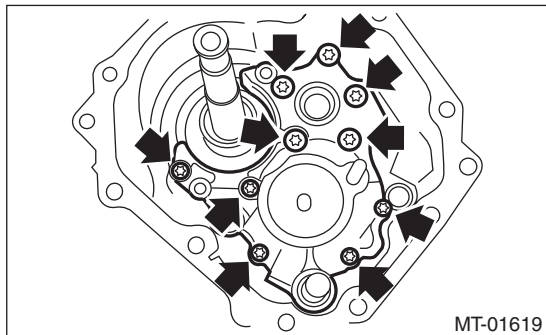

13) Remove the thrust washer on the main shaft section.

14) Remove the driven gear assembly shim and spacer.

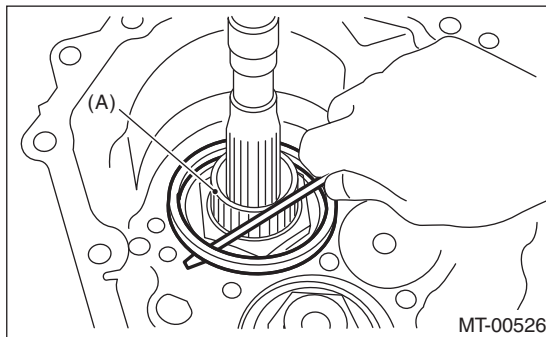

(A) Driven gear ASSY

15) Remove the snap ring.

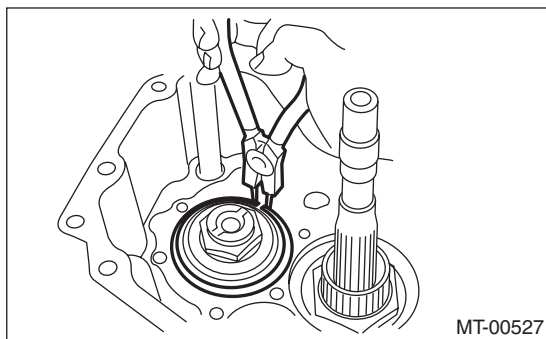

16) Remove the pilot bolt.

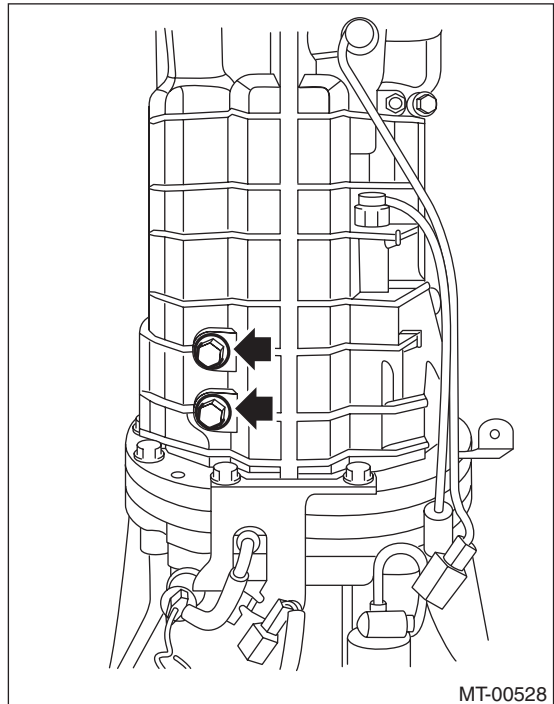

17) Remove the holder reverse bolt.

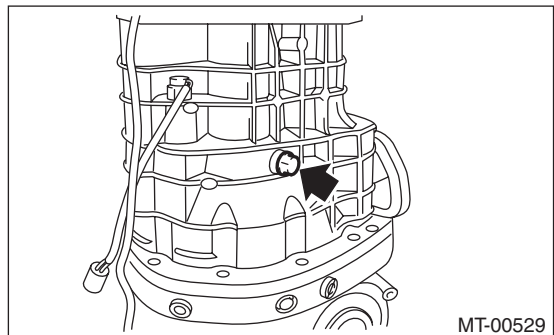

18) Remove the transmission case.

NOTE:

If the oil guide is caught between the shift fork, it may be difficult to remove the transmission case. Move the oil guide, then remove. Do not pull on the transmission case with excessive force.

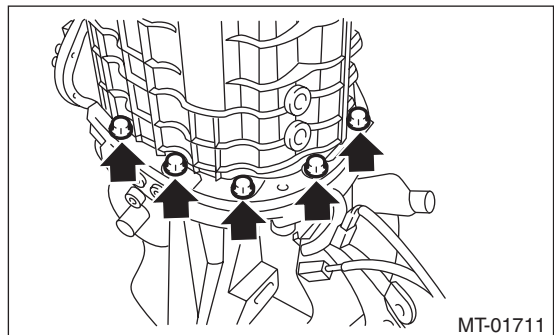

19) Remove any remaining liquid gasket from the transmission case and adapter plate.

Transmission Case

MANUAL TRANSMISSION AND DIFFERENTIAL

Brought to you by
NOVA
SALES
Meris Studios

B: INSTALLATION

1) Check that the shifter fork and the interlock block are both shifted into the neutral position. If they are not, shift into the neutral position.

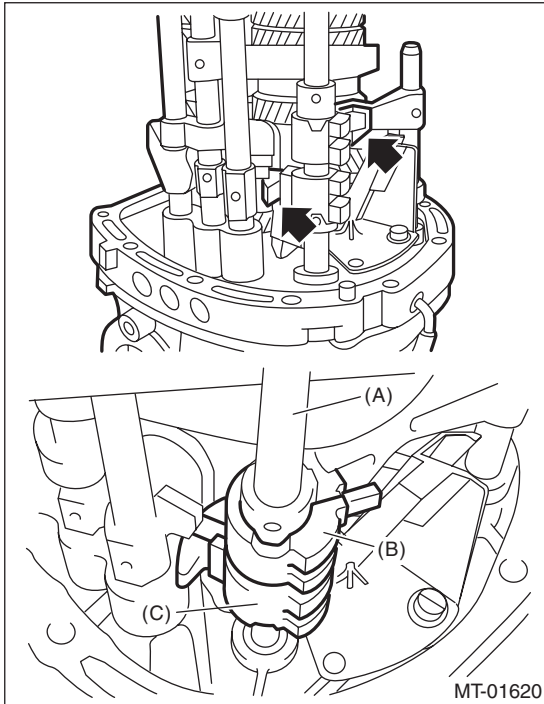

- (A) Striking rod
- (B) Reverse interlock block
- (C) Interlock block

2) Apply liquid gasket to the adapter plate.

Liquid gasket:
THREE BOND 1215 (Part No. 004403007) or equivalent

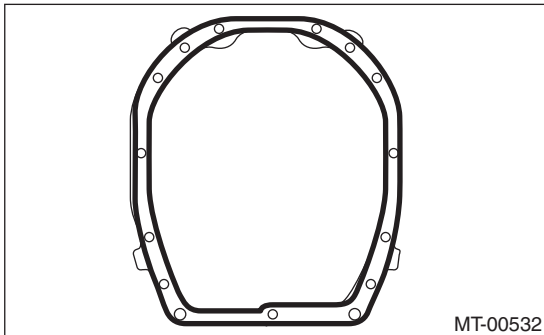

3) Install the transmission case.

4) By inspecting from the pilot bolt attachment hole, check that the interlock block and the reverse interlock block are aligned in the neutral position. If not aligned in neutral, remove the transmission case, and shift the shifter fork and interlock block to the neutral position.

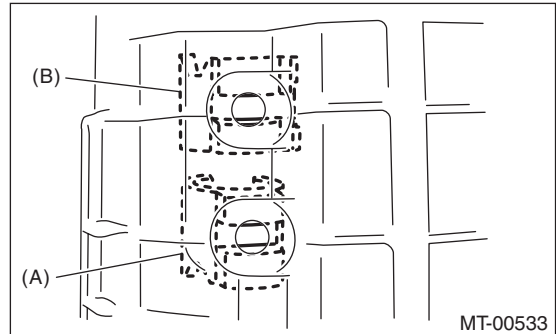

- (A) Interlock block
- (B) Reverse interlock block

5) Temporarily attach the pilot bolt with a new gasket.

6) Affix the transmission case with the bolts and nuts.

Tightening torque:
50 N·m (5.1 kgf-m, 36.9 ft-lb)

7) Tighten the pilot bolt.

Tightening torque:
34 N·m (3.5 kgf-m, 25.1 ft-lb)

8) Tighten the holder reverse bolt.

Tightening torque:
25 N·m (2.5 kgf-m, 18.4 ft-lb)

Transmission Case

MANUAL TRANSMISSION AND DIFFERENTIAL

Brought to you by Eris Studios
NOT FOR SALE

9) Install the snap ring, washer and collar of the driven gear assembly.

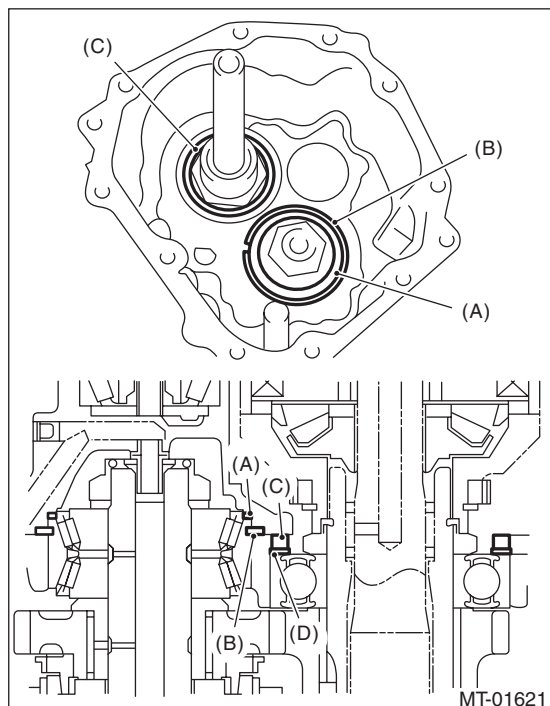

- (A) Washer
- (B) Snap ring
- (C) Collar
- (D) Washer

10) Attach the thrust washer to the main shaft.

11) Install the transfer bearing holder.

Tightening torque:

25 N·m (2.5 kgf·m, 18.4 ft·lb)

ST 18663AA000 SOCKET

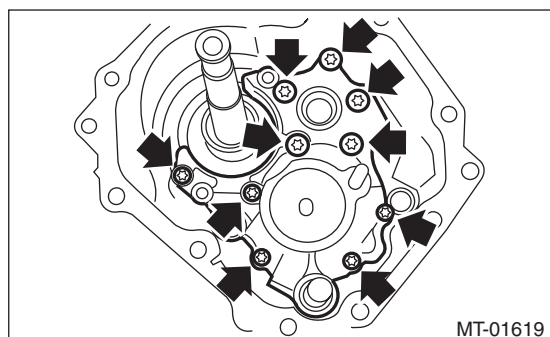

12) When replacing the transfer bearing holder, select the appropriate transfer driven gear and thrust washer, and install to the extension case. <Ref. to 6MT-47, ADJUSTMENT, Extension Case.>

13) Install the selector arm No. 2 and the shifter arm.

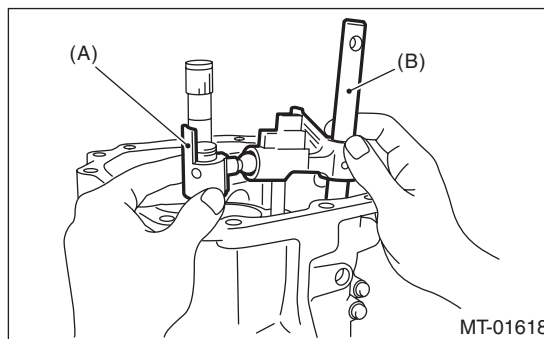

- (A) Selector arm No. 2
- (B) Shifter arm

14) Install a new spring pin.

15) Using the ST, install the neutral set spring.

ST1 18756AA000 CLAW

ST2 399893600 PLIER

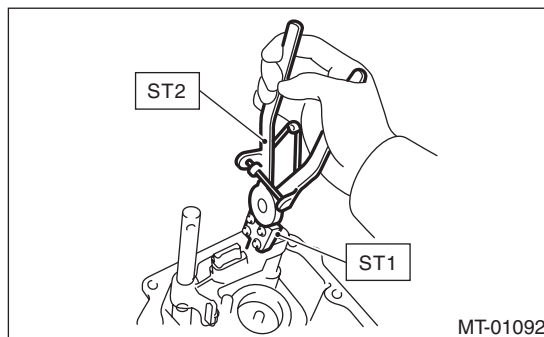

16) Install the snap ring and flat washer to the selector arm area.

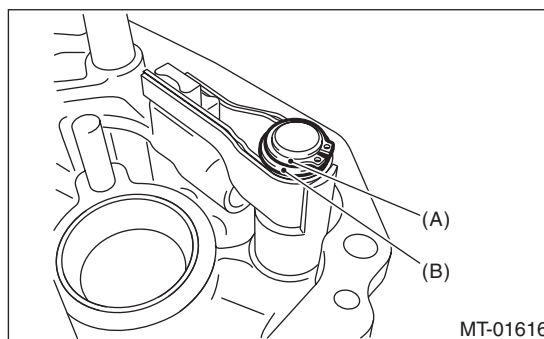

- (A) Snap ring
- (B) Flat washer

Transmission Case

MANUAL TRANSMISSION AND DIFFERENTIAL

Brought to you by
NOT FOR SALE
Peris Studios

17) Install the oil guides G and H.

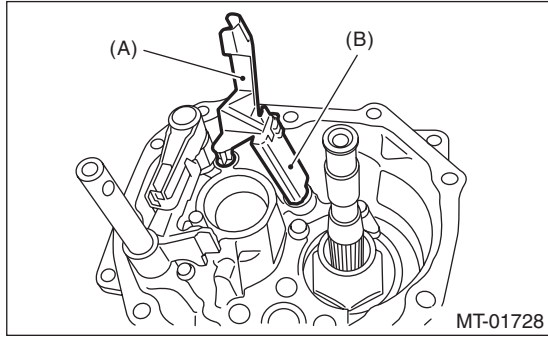

- (A) Oil guide G
- (B) Oil guide H

18) Install the center differential. <Ref. to 6MT-58, INSTALLATION, Center Differential.>

19) Install the transfer driven gear. <Ref. to 6MT-56, INSTALLATION, Transfer Driven Gear.>

20) Install the extension case. <Ref. to 6MT-44, INSTALLATION, Extension Case.>

21) Install the neutral position switch, back-up light switch and harness. <Ref. to 6MT-42, INSTALLATION, Neutral Position Switch.> <Ref. to 6MT-40, INSTALLATION, Back-up Light Switch.>

22) Install the manual transmission assembly to the vehicle. <Ref. to 6MT-34, INSTALLATION, Manual Transmission Assembly.>

C: DISASSEMBLY

1) Remove the transmission harness from the transmission case.

NOTE:

Remove the connector by disengaging the connector claw from the inside of the transmission.

2) Remove the oil guides C, D, E, F and harness bracket.

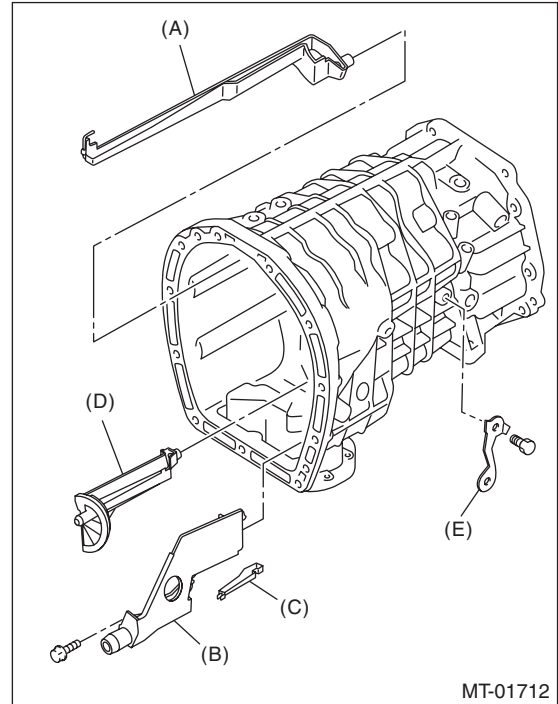

- (A) Oil guide C
- (B) Oil guide D
- (C) Oil guide E
- (D) Oil guide F
- (E) Harness bracket

3) Remove the oil pan.

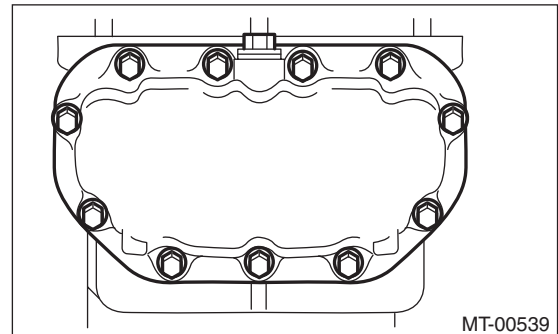

4) Remove any remaining liquid gasket from the transmission case and oil pan.

Transmission Case

MANUAL TRANSMISSION AND DIFFERENTIAL

Brought to you by Eris Studios
NOT FOR RESALE

D: ASSEMBLY

1) Apply liquid gasket to the oil pan.

Liquid gasket:

THREE BOND 1215 (Part No. 004403007) or equivalent

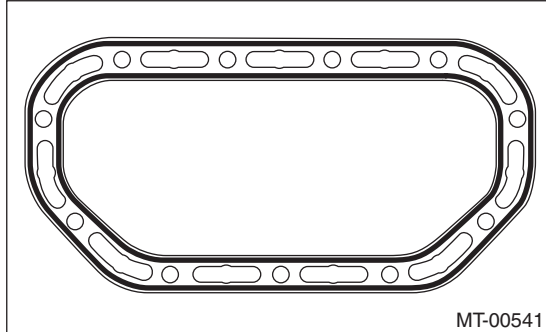

2) Install the oil pan.

Tightening torque:

6.4 N·m (0.7 kgf-m, 4.7 ft-lb)

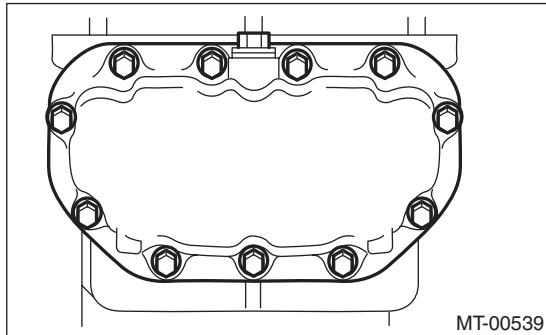

3) Install the oil guides C, D, E, F and harness bracket.

Tightening torque:

T1: 16 N·m (1.6 kgf-m, 11.8 ft-lb)

T2: 18 N·m (1.8 kgf-m, 13.3 ft-lb)

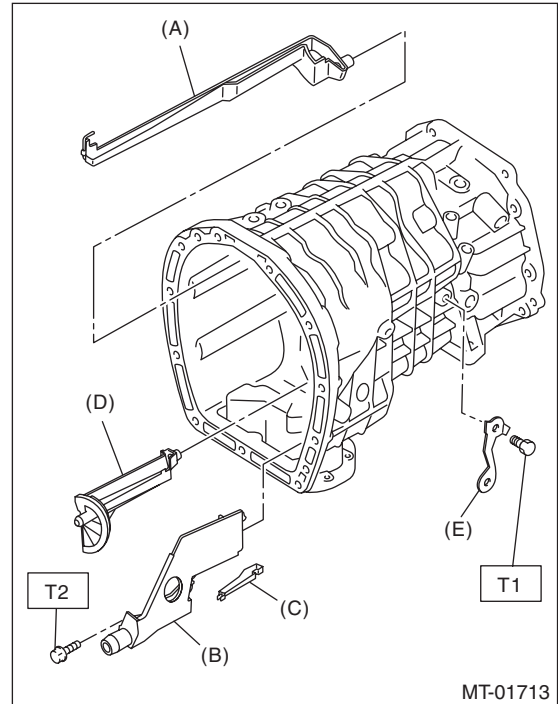

- (A) Oil guide C
- (B) Oil guide D
- (C) Oil guide E
- (D) Oil guide F
- (E) Harness bracket

Transmission Case

MANUAL TRANSMISSION AND DIFFERENTIAL

Brought to you by
NOT FOR SALE
Chris Studios

4) Attach the transmission harness to the transmission.

NOTE:

Install the transmission harness connector by aligning the protrusions of the transmission and transmission harness connector.

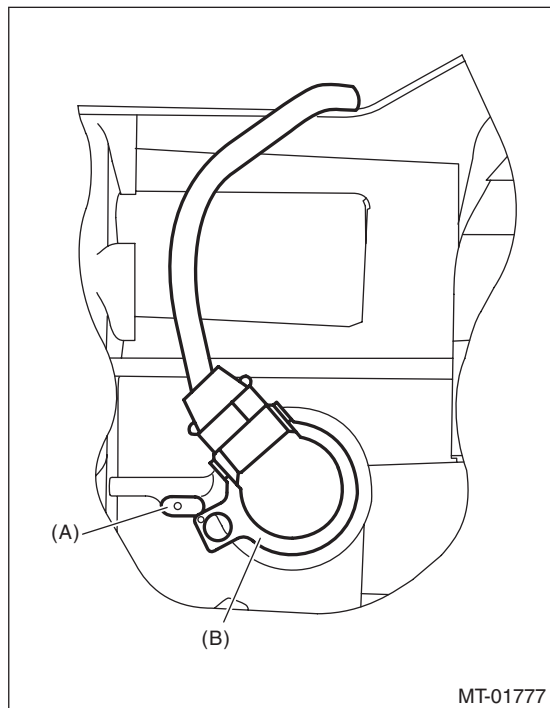

(A) Protrusion

(B) Transmission harness connectors

E: INSPECTION

- 1) If the sludge is accumulated in the oil pan, use a waste cloth to wipe it off completely.
- 2) Check that there is no damage on any parts. Replace damaged parts with new parts.

Main Shaft Assembly

MANUAL TRANSMISSION AND DIFFERENTIAL

Brought to you by Eris Studios
NOT FOR RESALE

17. Main Shaft Assembly

A: REMOVAL

- 1) Remove the manual transmission assembly from the vehicle. <Ref. to 6MT-32, REMOVAL, Manual Transmission Assembly.>
- 2) Prepare the transmission for overhaul. <Ref. to 6MT-38, Preparation for Overhaul.>
- 3) Remove the neutral position switch, back-up light switch and harness. <Ref. to 6MT-42, REMOVAL, Neutral Position Switch.> <Ref. to 6MT-40, REMOVAL, Back-up Light Switch.>
- 4) Remove the extension case. <Ref. to 6MT-44, REMOVAL, Extension Case.>
- 5) Remove the transfer driven gear. <Ref. to 6MT-56, REMOVAL, Transfer Driven Gear.>
- 6) Remove the center differential. <Ref. to 6MT-58, REMOVAL, Center Differential.>
- 7) Remove the transmission case. <Ref. to 6MT-59, REMOVAL, Transmission Case.>
- 8) Remove the striking rod.
- 9) Remove the oil guide B.

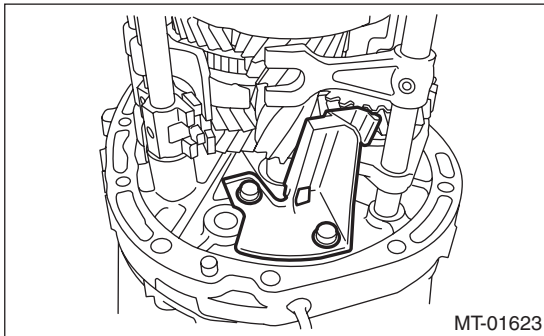

- 10) Use a screw driver to shift to the 4th gear position.

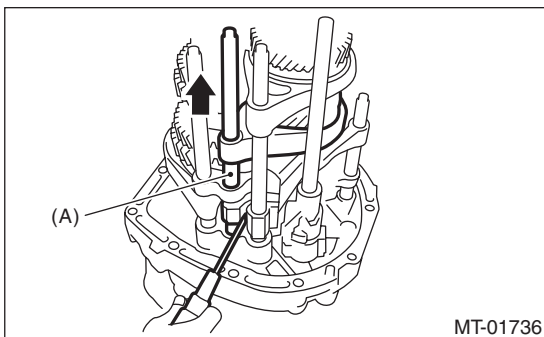

(A) 3rd-4th shift rod

- 11) Remove the reverse idler holder.

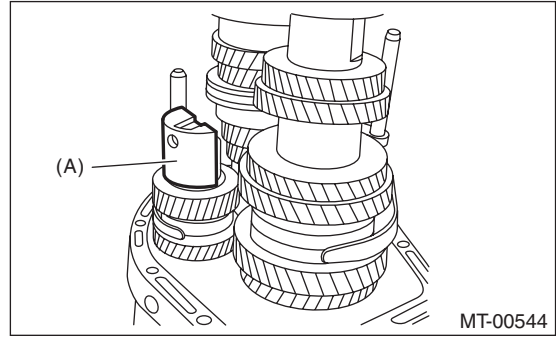

(A) Reverse idler holder

- 12) Remove the check plug, O-ring, check spring, plunger and check ball from the adapter plate.

NOTE:

Do not reuse the gasket.

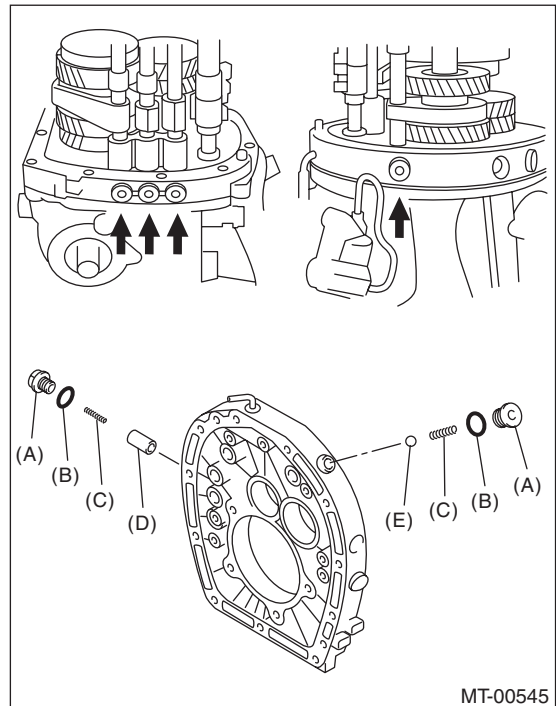

- (A) Check plug
- (B) O-ring
- (C) Checking spring
- (D) Plunger
- (E) Check ball

Main Shaft Assembly

MANUAL TRANSMISSION AND DIFFERENTIAL

Brought to you by
NOVA Studios
NOT FOR SALE

13) Remove the bolt and gasket holding the reverse idler shaft.

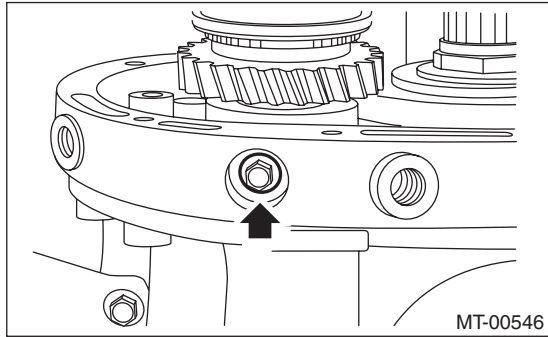

14) Push the main shaft assembly, driven gear assembly, reverse idler gear and shifter forks to remove from the adapter plate all at once.

NOTE:

A helper is required to perform this work.

B: INSTALLATION

1) Adjust the 3rd-4th and 5th-6th shifter fork rods. <Ref. to 6MT-115, ADJUSTMENT, Shifter Fork and Rod.>

2) Turn the sub gear counterclockwise for approximately 3 teeth. Match the sub gear and reverse idler gear holes, and insert the ST.

ST 18757AA000 STRAIGHT PIN

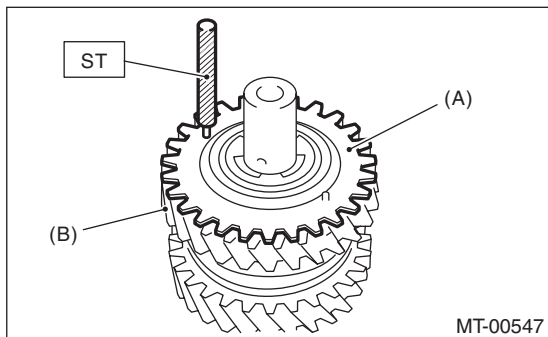

- (A) Sub gear
- (B) Reverse idler gear

3) Attach the driven gear assembly to the 1st-2nd shifter fork assembly.

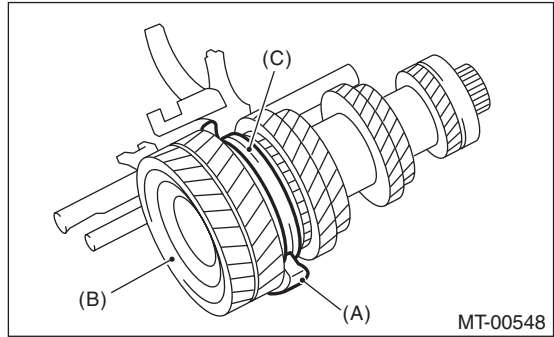

- (A) 1st-2nd shifter fork
- (B) Driven gear ASSY
- (C) 1st-2nd sleeve

4) Attach the main shaft assembly to the 3rd-4th shifter fork, and assemble to the driven gear assembly.

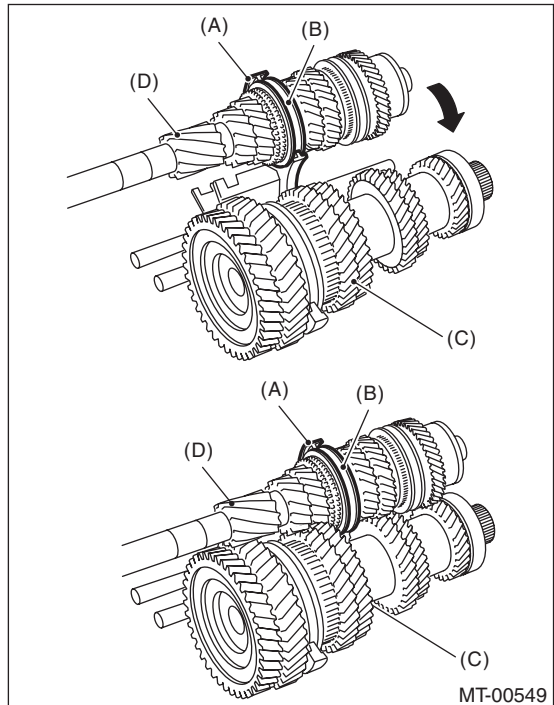

- (A) 3rd-4th shifter fork
- (B) 3rd-4th sleeve
- (C) Driven gear ASSY
- (D) Main shaft ASSY

Main Shaft Assembly

MANUAL TRANSMISSION AND DIFFERENTIAL

Brought to you by Eris Studios
NOT FOR RESALE

5) Attach the 5th-6th shifter fork assembly to the main shaft assembly.

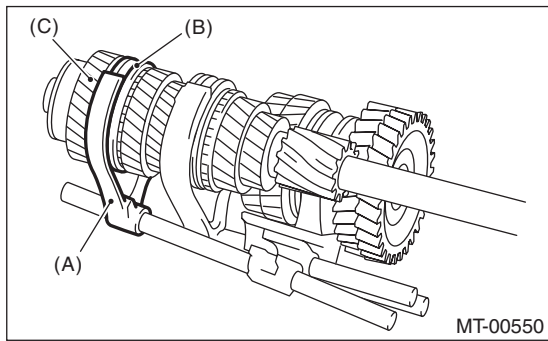

- (A) 5th-6th shifter fork
- (B) 5th-6th sleeve
- (C) Main shaft ASSY

6) Attach the reverse shifter fork assembly to the reverse idler gear assembly.

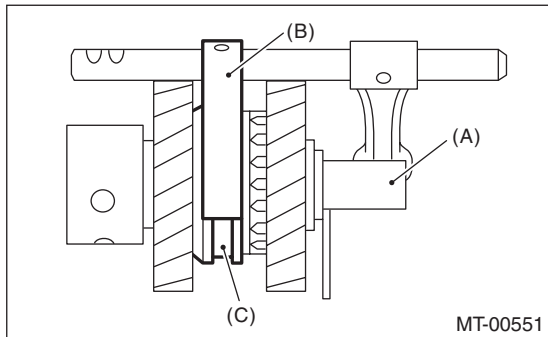

- (A) Reverse idler gear ASSY
- (B) Reverse shifter fork
- (C) Reverse sleeve

7) Install the reverse idler gear assembly.

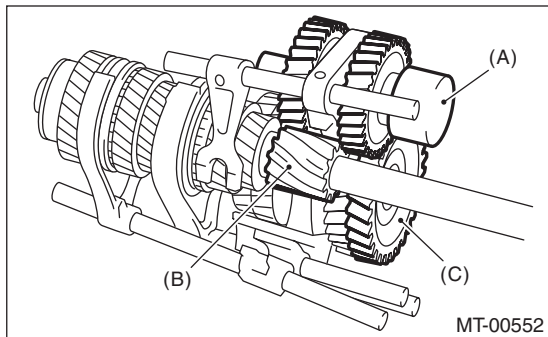

- (A) Reverse idler gear ASSY
- (B) 1st drive gear
- (C) Reverse gear

8) Install the thrust bearing of the driven gear assembly.

9) Push on the shifter forks, main shaft assembly, driven gear assembly and reverse idler gear assemblies, to attach to the adapter plate all at once.

NOTE:

A helper is required to perform this work.

10) Install the plunger, check spring, new O-ring and check plugs.

Tightening torque:

37 N·m (3.8 kgf·m, 27.3 ft·lb)

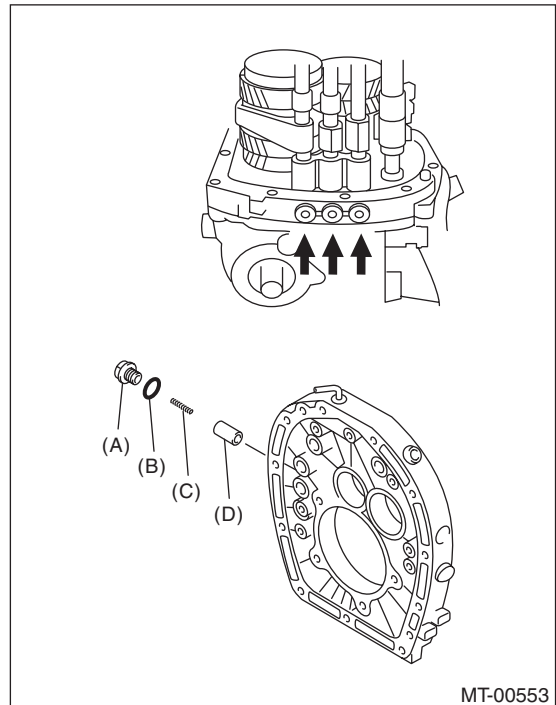

- (A) Check plug
- (B) O-ring
- (C) Checking spring
- (D) Plunger

Main Shaft Assembly

MANUAL TRANSMISSION AND DIFFERENTIAL

Brought to you by
NOZON
SALES
Peris Studios

11) Install the check ball, check spring, new O-ring and check plugs.

Tightening torque:

37 N·m (3.8 kgf·m, 27.3 ft·lb)

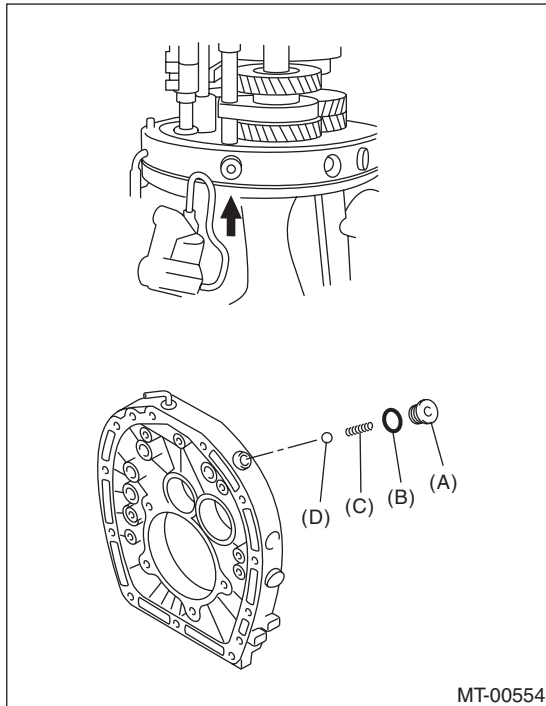

- (A) Check ball
- (B) O-ring
- (C) Checking spring
- (D) Check plug

12) Attach the bolt and a new gasket.

Tightening torque:

25 N·m (2.5 kgf·m, 18.4 ft·lb)

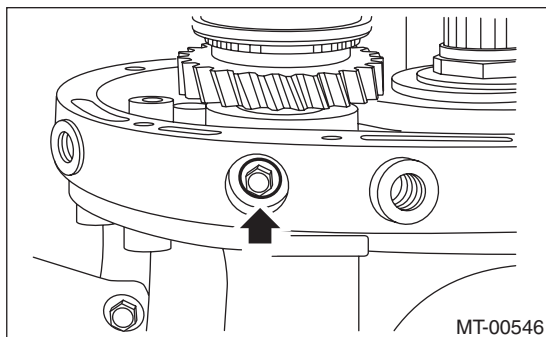

13) Use a screw driver to shift to the 4th gear position.

14) Install the reverse idler holder.

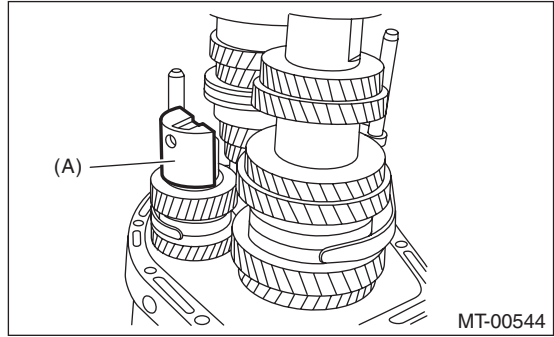

(A) Reverse idler holder

15) Install the oil guide B.

Tightening torque:

18 N·m (1.8 kgf·m, 13.3 ft·lb)

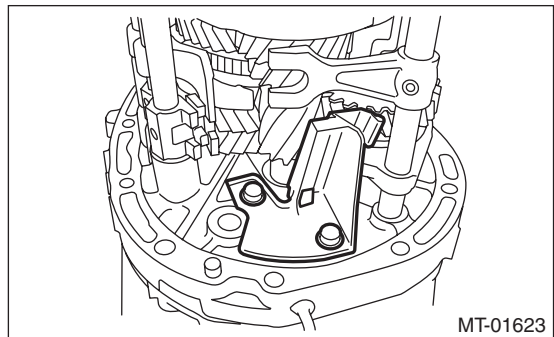

16) Install the striking rod.

17) Install the transmission case. <Ref. to 6MT-61, INSTALLATION, Transmission Case.>

18) Install the selected main shaft snap ring and washers.

19) Install the center differential. <Ref. to 6MT-58, INSTALLATION, Center Differential.>

20) Install the transfer driven gear. <Ref. to 6MT-56, INSTALLATION, Transfer Driven Gear.>

21) Install the extension case. <Ref. to 6MT-44, INSTALLATION, Extension Case.>

22) Install the neutral position switch, back-up light switch and harness. <Ref. to 6MT-42, INSTALLATION, Neutral Position Switch.> <Ref. to 6MT-40, INSTALLATION, Back-up Light Switch.>

23) Install the manual transmission assembly to the vehicle. <Ref. to 6MT-34, INSTALLATION, Manual Transmission Assembly.>

Main Shaft Assembly

MANUAL TRANSMISSION AND DIFFERENTIAL

Brought to you by Eris Studios
NOT FOR RESALE

C: DISASSEMBLY

NOTE:

Individual sleeves and hubs meet at a specified position. Before disassembly, mark the meeting position of the sleeve and hub.

1) Affix the ST to the work table.

ST 18664AA000 BASE

2) Flatten the locknut tab.

3) Set the main shaft assembly to the ST, and remove the lock nut and washer.

ST1 18665AA000 HOLDER

ST2 18664AA000 BASE

NOTE:

Use a 38 mm socket wrench.

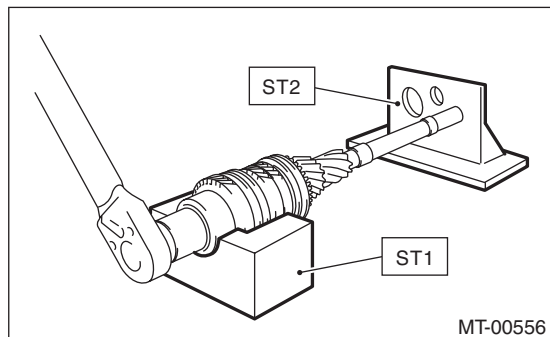

4) Remove the main shaft assembly from the ST.

5) Set the ST1 to the 6th drive gear, and use a press to remove the taper roller bearing, bushing and 6th drive gear.

ST1 18722AA010 REMOVER

ST2 899864100 REMOVER

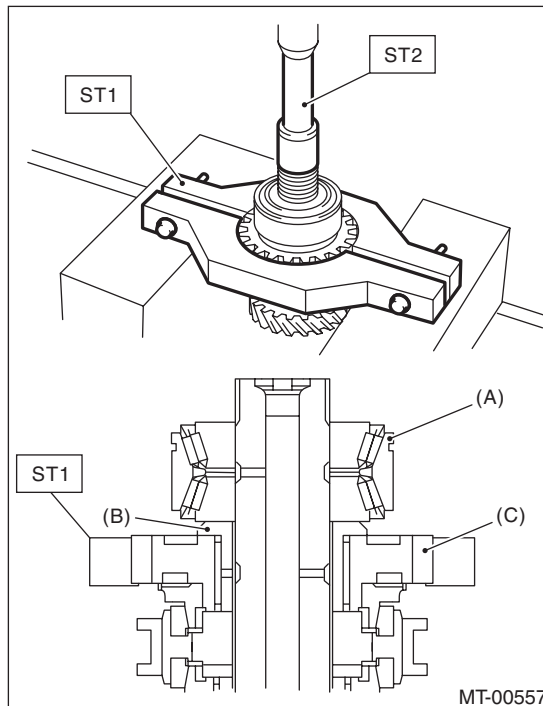

(A) Taper roller bearing

(B) Bushing

(C) 6th drive gear

6) Remove the 5th-6th sleeve, 6th needle bearing and 6th baulk ring.

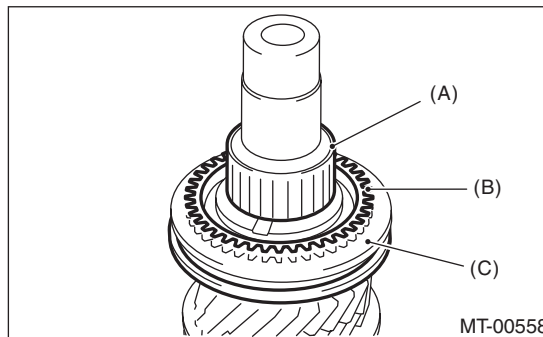

(A) Needle bearing

(B) 6th baulk ring

(C) 5th-6th sleeve

Main Shaft Assembly

MANUAL TRANSMISSION AND DIFFERENTIAL

Brought to you by
NOT FOR SALE
Peris Studios

7) Set the ST to the 3rd drive gear, and use a press to remove individual parts.

ST 18720AA000 REMOVER

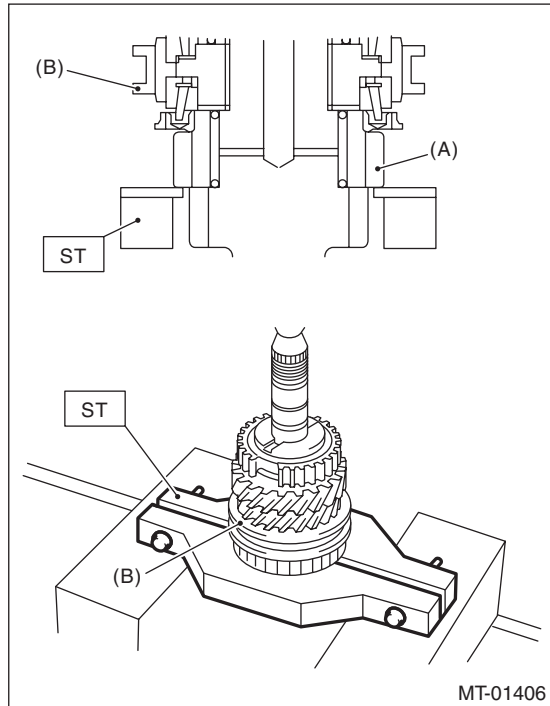

- (A) 3rd drive gear
- (B) 3rd-4th sleeve

D: ASSEMBLY

NOTE:

When replacing the following parts, replace as a set.

- Sleeve and hub
- Outer baulk ring, 3rd synchro cone and inner baulk ring
- Taper roller bearing

1) Apply adequate transmission gear oil to the main shaft, 3rd needle bearing and 3rd drive gear inner surface.

2) Install the 3rd needle bearing and 3rd drive gear to the main shaft.

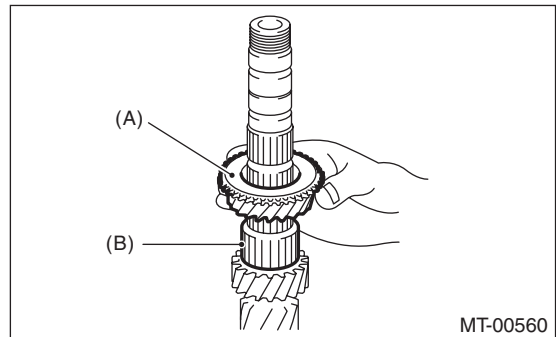

- (A) 3rd needle bearing
- (B) 3rd drive gear

3) Install the inner baulk ring, 3rd synchro cone and outer baulk ring.

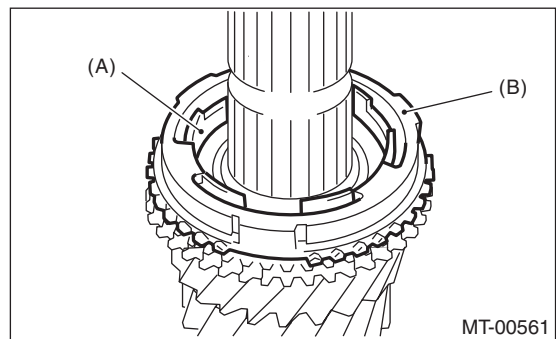

- (A) Inner baulk ring
- (B) Outer baulk ring

Main Shaft Assembly

MANUAL TRANSMISSION AND DIFFERENTIAL

Brought to you by Eris Studios
NOT FOR RESALE

NOTE:

Install the 3rd synchro cone by aligning the protrusion of the 3rd synchro cone with the hole on the 3rd drive gear.

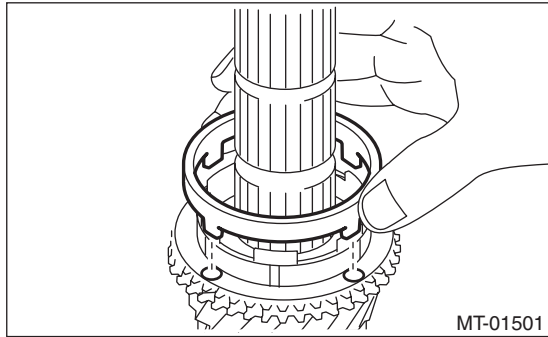

4) Install the 3rd-4th hub and 4th bushing.

(1) Being careful of the install direction of the 3rd-4th hub, set to the main shaft.

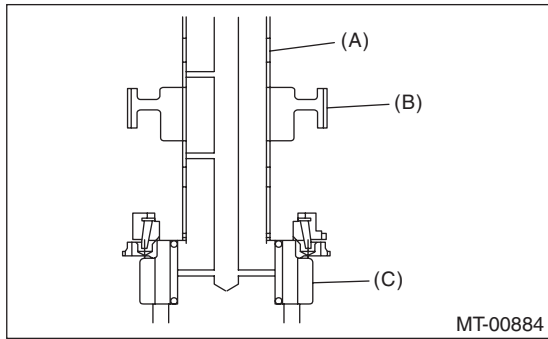

- (A) Main shaft
- (B) 3rd-4th hub
- (C) 3rd drive gear

(2) Being careful not to cover the oil holes of the main shaft and 4th bushing, attach to the main shaft.

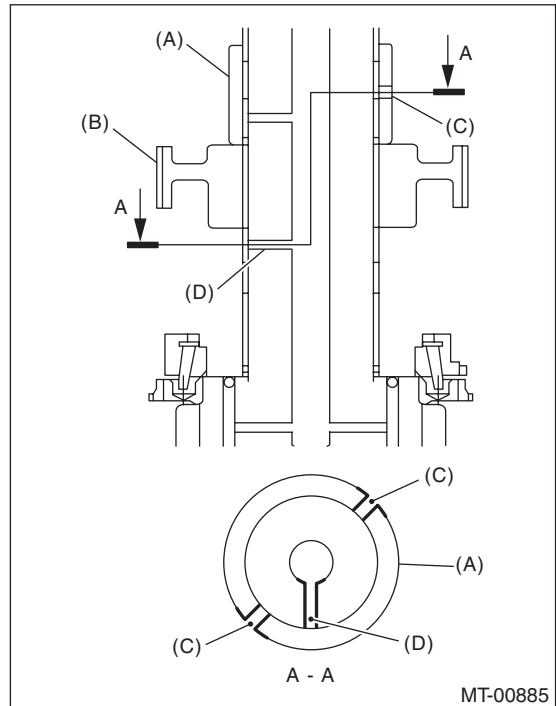

- (A) 4th bushing
- (B) 3rd-4th hub
- (C) 4th bushing oil hole
- (D) Main shaft oil hole

Main Shaft Assembly

Brought to you by
NOT FOR SALE
Meris Studios

(3) Using the ST, push in to the 3rd-4th hub and 4th bushing all at once.

ST1 18651AA000 INSTALLER
ST2 398177700 INSTALLER

CAUTION:

Do not apply pressure in excess of 40 kN (4.0 ton, 4.4 US ton, 3.9 Imp ton).

NOTE:

When pushing into the 3rd-4th hub and 4th bushing, move the outer baulk ring to match the protrusion of the outer baulk ring and the cut out on the 3rd-4th bushing.

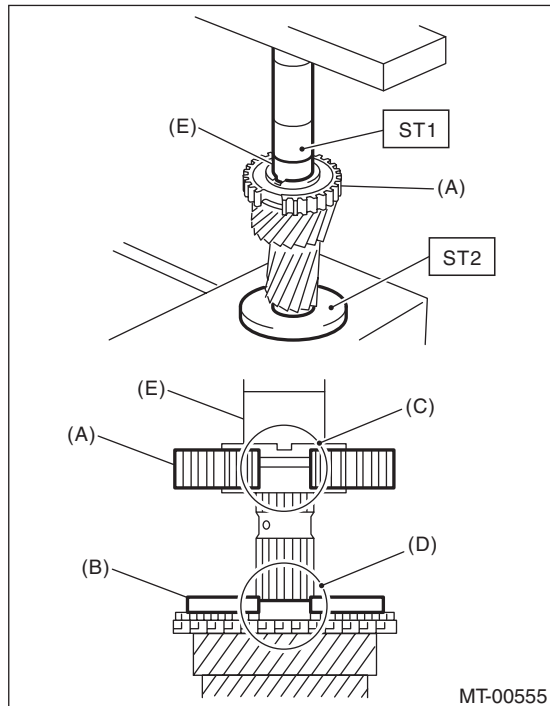

- (A) 3rd-4th hub
- (B) Outer baulk ring
- (C) Cut out on the 3rd-4th hub
- (D) Protrusion of the outer baulk ring
- (E) 4th bushing

5) Make sure that the 3rd drive gear can be turned smoothly by hand. If it does not turn smoothly, re-assemble.

6) Attach the 3rd-4th shifting insert key at the appropriate position of the 3rd-4th sleeve.

NOTE:

- The location angle of each shifting insert key is 120°.
- Refer to the following figure to install the shifting insert key.

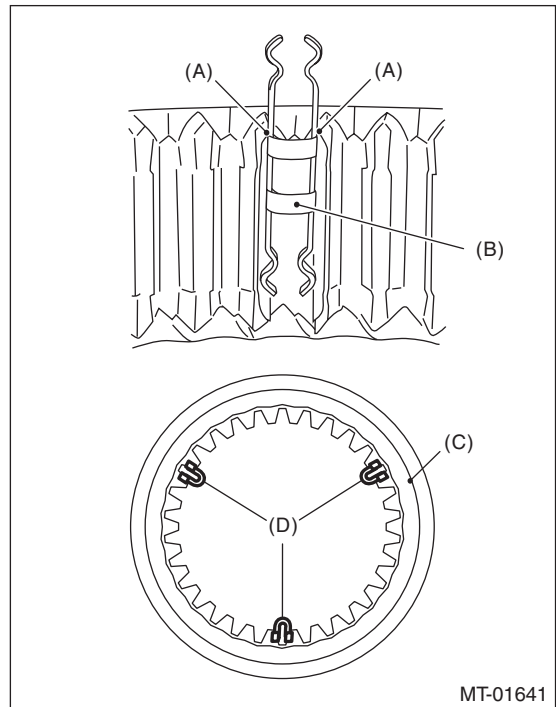

- (A) Attach the straight part of the shifting insert key to the sleeve convex portion.
- (B) Shifting insert key
- (C) 3rd-4th sleeve
- (D) 3rd-4th shifting insert key

7) Attach the 3rd-4th sleeve to the 3rd-4th hub.

NOTE:

- There is an identification groove on the 3rd-4th sleeve.
- Place the groove towards the 3rd drive gear, and attach the 3rd-4th sleeve.

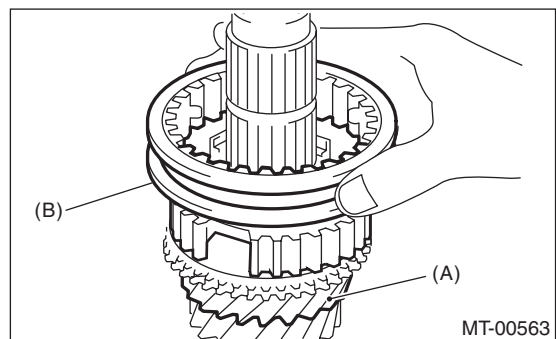

- (A) 3rd drive gear
- (B) 3rd-4th sleeve identification groove (1)

Main Shaft Assembly

MANUAL TRANSMISSION AND DIFFERENTIAL

Brought to you by Eris Studios
NOT FOR RESALE

8) Install the 4th baulk ring.

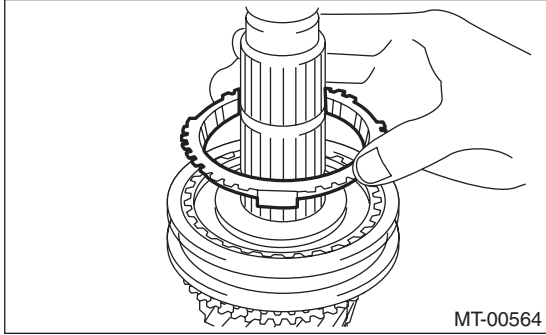

9) Apply adequate transmission gear oil to the main shaft, 4th needle bearing and 4th drive gear inner surface.

10) Install the 4th needle bearing and 4th drive gear.

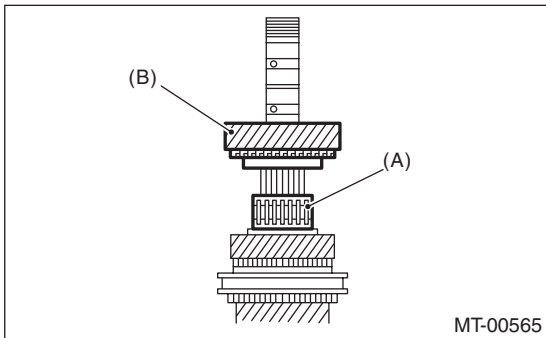

- (A) 4th needle bearing
- (B) 4th drive gear

11) Install the 5th bushing.

(1) Being careful not to cover the oil holes of the main shaft and 5th bushing, attach to the main shaft.

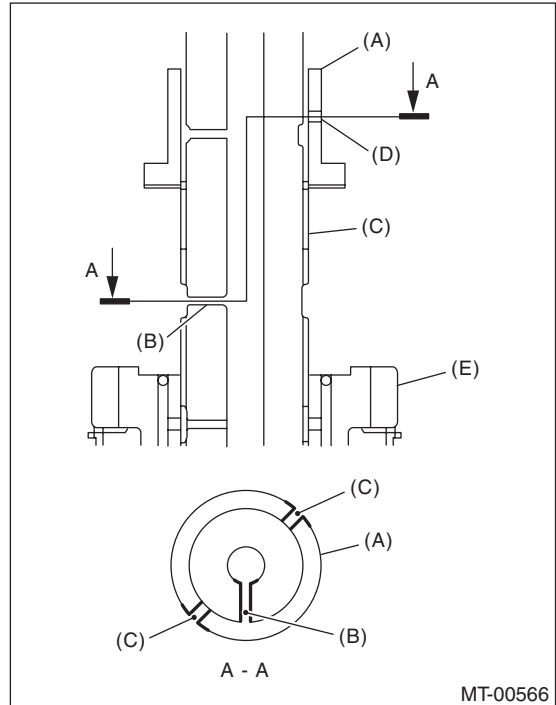

- (A) 5th bushing
- (B) Main shaft oil hole
- (C) Main shaft
- (D) 5th bushing oil hole
- (E) 4th drive gear

(2) Using the ST, push into the 5th bushing.

ST1 18651AA000 INSTALLER

ST2 398177700 INSTALLER

CAUTION:

Do not apply pressure in excess of 40 kN (4.0 ton, 4.4 US ton, 3.9 Imp ton).

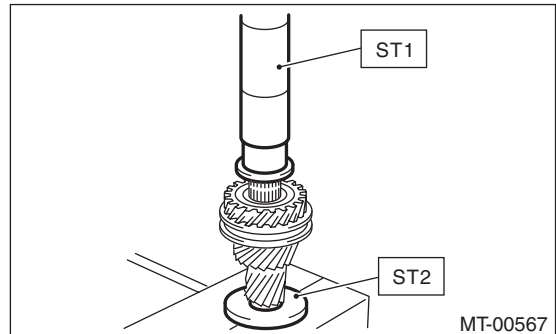

12) Make sure that the 4th drive gear can be turned smoothly by hand. If it does not turn smoothly, re-assemble.

13) Apply adequate transmission gear oil to the main shaft, 5th needle bearing and 5th drive gear inner surface.

Main Shaft Assembly

MANUAL TRANSMISSION AND DIFFERENTIAL

Brought to you by
NOT FOR SALE
Peris Studios

14) Install the 5th needle bearing and 5th drive gear.

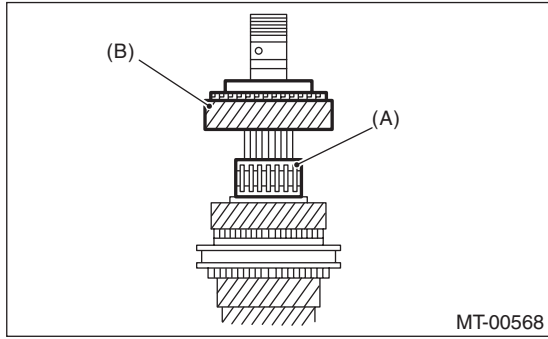

- (A) 5th needle bearing
- (B) 5th drive gear

15) Install the 5th baulk ring.

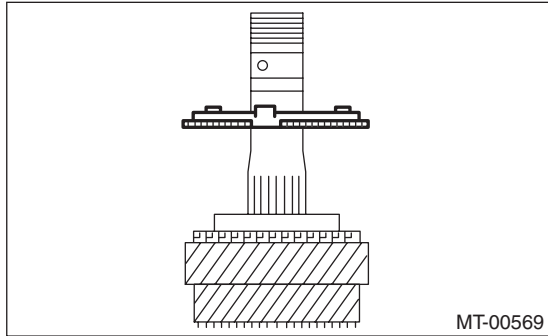

16) Install the 5th-6th hub.

(1) Being careful of the install direction of the 5th-6th hub, set to the main shaft.

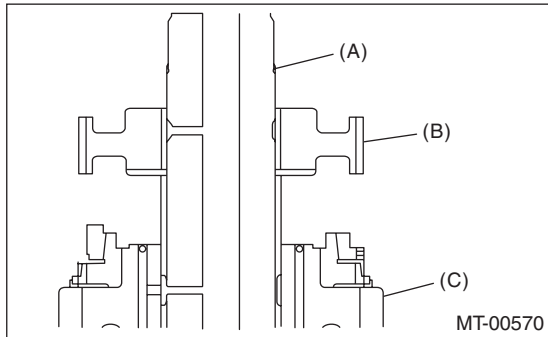

- (A) Main shaft
- (B) 5th-6th hub
- (C) 5th drive gear

(2) Using the ST, push into the 5th-6th hub.

ST1 18651AA000 INSTALLER

ST2 398177700 INSTALLER

CAUTION:

Do not apply pressure in excess of 40 kN (4.0 ton, 4.4 US ton, 3.9 Imp ton).

NOTE:

When pushing into the 5th-6th hub, move the outer baulk ring to match the protrusion of the outer baulk ring and the cut out on the 5th-6th bushing.

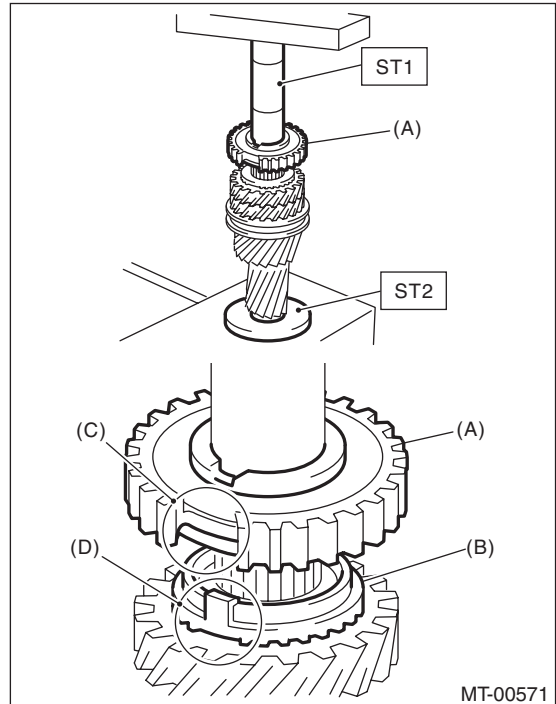

- (A) 5th-6th hub
- (B) Outer baulk ring
- (C) Cut out on the 5th-6th hub
- (D) Protrusion of the outer baulk ring

17) Make sure that the 5th drive gear can be turned smoothly by hand. If it does not turn smoothly, re-assemble.

Main Shaft Assembly

MANUAL TRANSMISSION AND DIFFERENTIAL

Brought to you by Eris Studios
NOT FOR RESALE

18) Attach the 5th-6th shifting insert key at the appropriate position of the 5th-6th sleeve.

NOTE:

- The location angle of each shifting insert key is 120°.
- Refer to the following figure to install the shifting insert key.

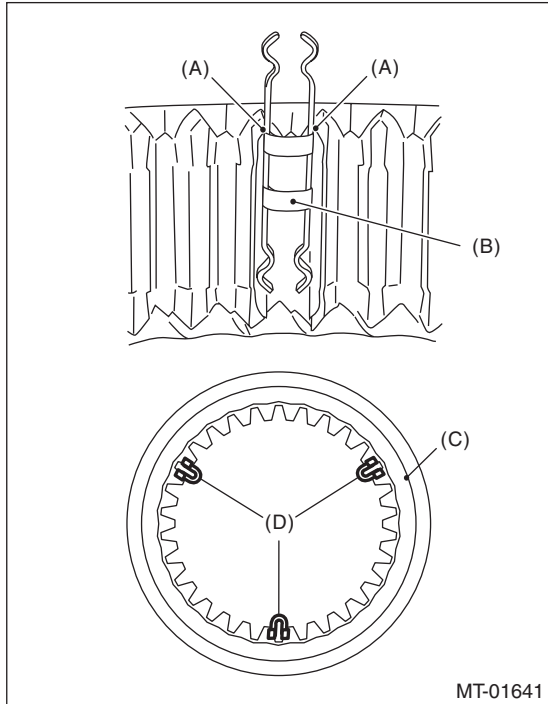

- (A) Attach the straight part of the shifting insert key to the sleeve convex portion.
- (B) Shifting insert key
- (C) 5th-6th sleeve
- (D) Shifting insert key

19) Attach the 5th-6th sleeve to the 5th-6th hub.

NOTE:

- There are two identification grooves on the 5th-6th sleeve.
- Place the grooves towards the 5th drive gear, and attach the 5th-6th sleeve.

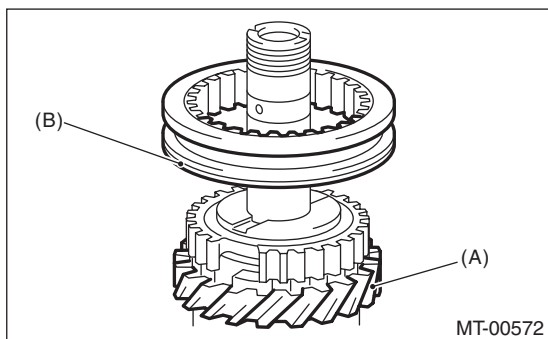

- (A) 5th drive gear
- (B) 5th-6th sleeve identification groove (2)

20) Install the 6th baulk ring.

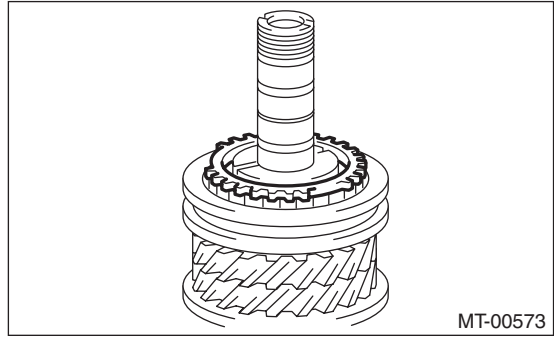

21) Apply adequate transmission gear oil to the main shaft, 6th needle bearing and 6th drive gear inner surface.

22) Install the 6th drive gear.

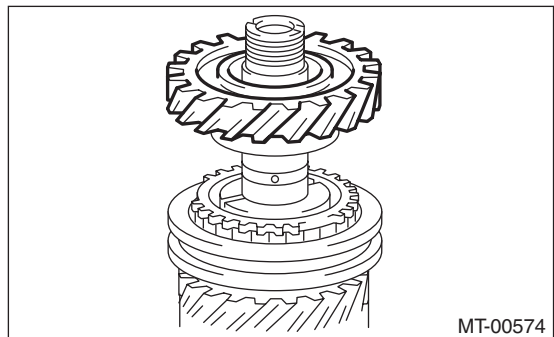

23) Install the 6th needle bearing.

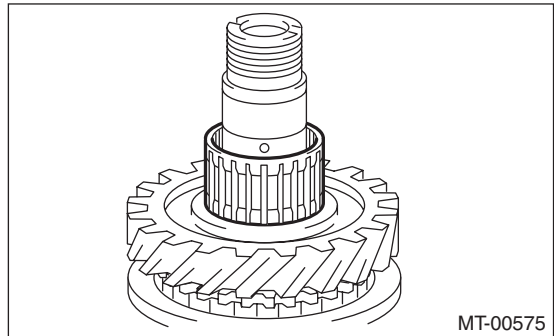

24) Being careful not to cover the oil holes of the 6th bushing and the main shaft, set the 6th bushing to the main shaft.

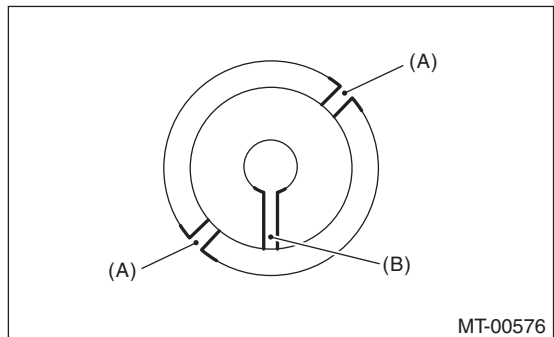

- (A) 6th bushing oil hole
- (B) Main shaft oil hole

Main Shaft Assembly

MANUAL TRANSMISSION AND DIFFERENTIAL

Brought to you by
NOT FOR SALE
Meris Studios

- 25) Using the ST, install the 6th bushing.
ST1 18651AA000 INSTALLER
ST2 398177700 INSTALLER

CAUTION:
Do not apply pressure in excess of 40 kN
(4.0 ton, 4.4 US ton, 3.9 Imp ton).

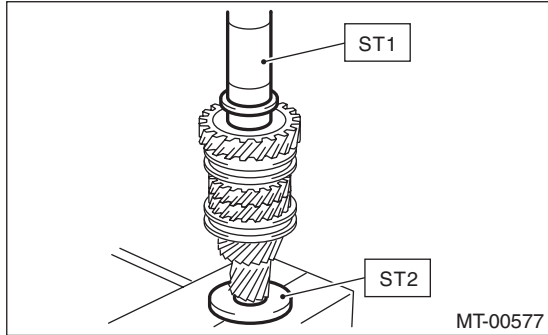

- 26) Make sure that the 6th drive gear can be turned smoothly by hand. If it does not turn smoothly, re-assemble.

- 27) Using the ST, install the inner bearing of the taper roller bearing.
ST1 18651AA000 INSTALLER
ST2 398177700 INSTALLER

CAUTION:
Do not apply pressure in excess of 40 kN
(4.0 ton, 4.4 US ton, 3.9 Imp ton).

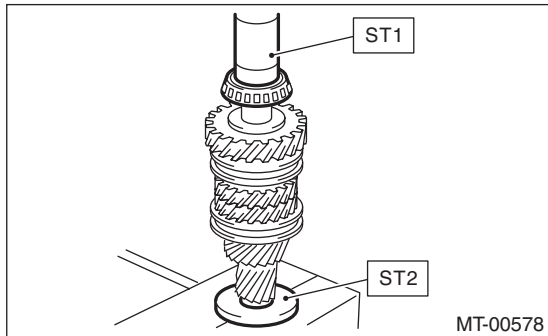

- 28) Using the ST, install the outer race and the outer bearing of the taper roller bearing.
ST1 18651AA000 INSTALLER
ST2 398177700 INSTALLER

CAUTION:
Do not apply pressure in excess of 40 kN
(4.0 ton, 4.4 US ton, 3.9 Imp ton).

NOTE:

- Confirm that the outer race is installed in the proper direction.
- Push in until there is no backlash on the outer race and the bearing turns smoothly by hand.

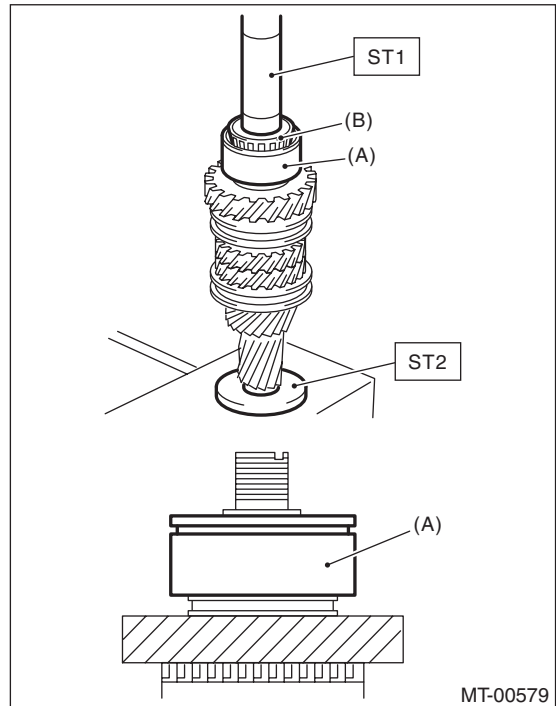

- (A) Outer race
- (B) Outer bearing of the taper roller bearing

- 29) Make sure that the taper roller bearing turns smoothly by hand. If it does not rotate smoothly, replace the taper roller bearing as a set, and re-assemble.

- 30) Attach the lock washer and a new lock nut.

Main Shaft Assembly

MANUAL TRANSMISSION AND DIFFERENTIAL

Brought to you by Eris Studios
NOT FOR RESALE

31) Set the main shaft assembly to the ST, and tighten the lock nut.

ST1 18665AA000 HOLDER

ST2 18664AA000 BASE

Tightening torque:

392 N·m (40.0 kgf·m, 289.1 ft·lb)

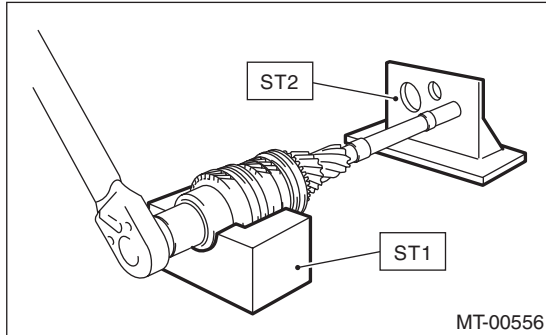

32) Using the ST, crimp the lock nut in 4 locations, with dimensions within $A = 27 \pm 0.3$ mm (1.06 ± 0.01 in).

ST 18668AA000 PUNCH

NOTE:

Do not damage the crimp area of the lock nut.

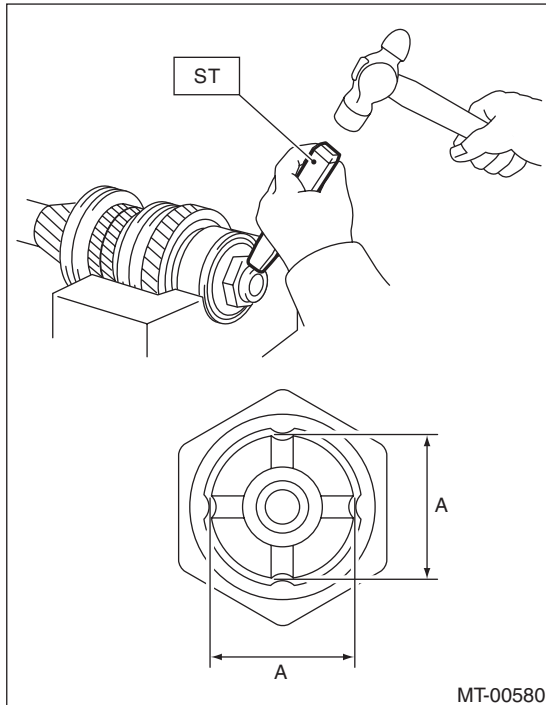

E: INSPECTION

Disassembled parts should be washed clean first with cleaning solvent and then inspected carefully.

1) Bearing

Replace the bearings in the following cases.

- Wear, rusting or damage of the bearings
- The bearing does not rotate smoothly or an abnormal noise is emitted when turning.

2) Bushing (each gear)

Replace the bushing in following cases.

- The sliding surface is damaged or abnormally worn.

3) Gear

Replace gears in the following cases.

- The gear teeth surface is damaged or excessively worn.
- If the contact area of the baulk ring is damaged.
- If the inner face of the gear is worn.

4) Baulk ring, synchro cone

Replace the baulk ring and synchro cone in following cases:

- Wear, rusting or damage of the baulk ring

5) Shifting insert key

Replace the shifting insert key if deformed, excessively worn or defective in any way.

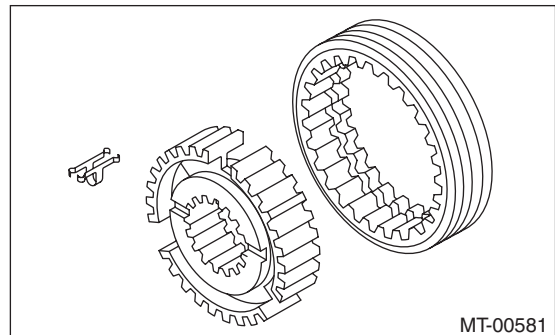

Main Shaft Assembly

MANUAL TRANSMISSION AND DIFFERENTIAL

Brought to you by
NOT FOR SALE
Peris Studios

F: ADJUSTMENT

1. MAIN SHAFT SNAP RING & WASHER SELECTION

NOTE:

In the following conditions, perform the procedures below.

- 1st to 6th driven gear replacement
- 1st and 2nd synchro ring assembly replacement
- Ball bearing replacement
- Adapter plate replacement
- Driven shaft replacement

1) Insert the drive pinion assembly into the adapter plate.

NOTE:

Confirm that the thrust bearing outer race has not been removed and the drive pinion is not lifted.

2) Set the height gauge to the adapter plate. Lower the height gauge indicator to the mating surface of the adapter plate and case, and set to zero points.

ST 18853AA000 HEIGHT GAUGE

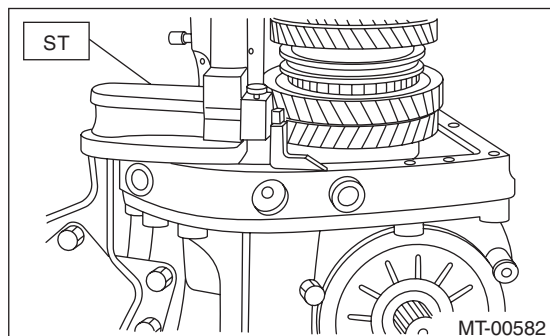

NOTE:

- The adapter plate will be the base point for the measurement. Use a scraper to remove any gasket material remaining on the end face.
- During measurement, do not place the height gauge in the shaded area shown in the figure.

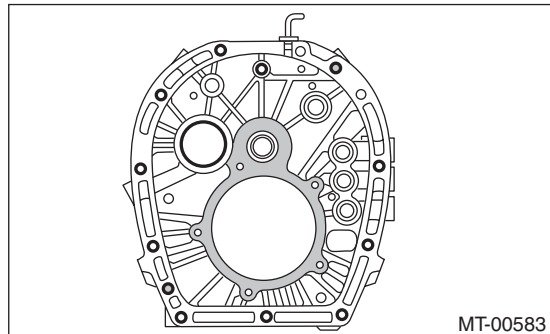

3) Measure the height to the ball bearing end face (height H).

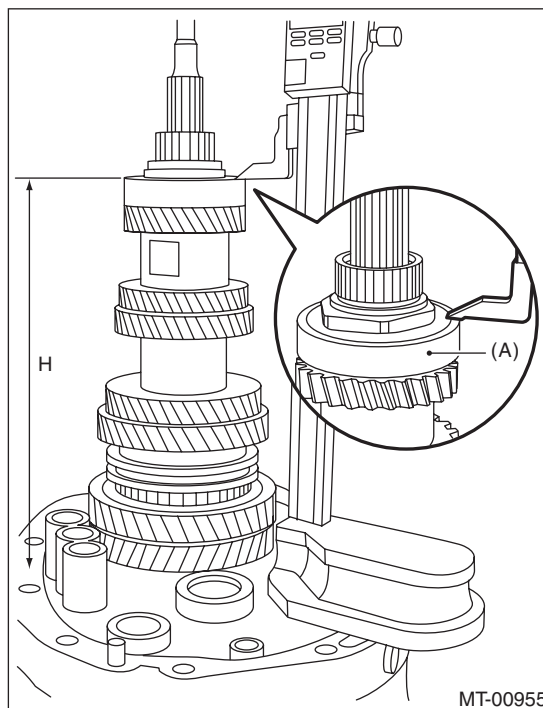

(A) Ball bearing

NOTE:

Set the height gauge indicator near the measurement target, and lock dial (1) as shown in the figure. Turn dial (2), and set the indicator to the end face of the bearing.

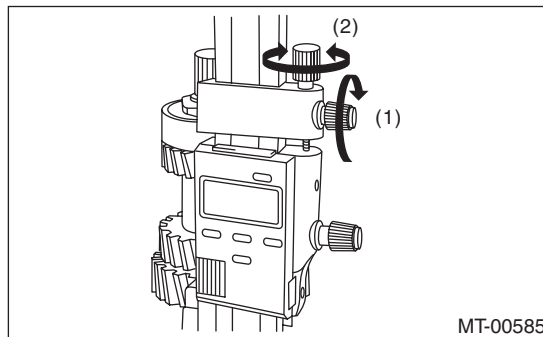

Turn approximately 120° at a time, and measure the ball bearing in 5 locations. Round off the 2 highest and 2 lowest measurement values. The remaining center value is used as the measurement value.

Main Shaft Assembly

MANUAL TRANSMISSION AND DIFFERENTIAL

Brought to you by Eris Studios
NOT FOR RESALE

4) According to the measurement value, select the snap ring and washer from the following table.

Snap ring

H: mm (in)	Part No.	Thickness: mm (in)
270.83 — 271.40 (10.66 — 10.69)	805072010	1.65 (0.065)
271.41 — 271.98 (10.69 — 10.71)	805072011	1.95 (0.077)
271.99 — 272.56 (10.71 — 10.73)	805072012	2.25 (0.089)

Washer

H: mm (in)	Part No.	Thickness: mm (in)
270.83 — 271.40 (10.66 — 10.69)	803067012	1.6 (0.063)
271.41 — 271.98 (10.69 — 10.71)	803067011	1.3 (0.051)
271.99 — 272.56 (10.71 — 10.73)	803067010	1.0 (0.039)

18. Driven Gear Assembly

A: REMOVAL

- 1) Remove the manual transmission assembly from the vehicle. <Ref. to 6MT-32, REMOVAL, Manual Transmission Assembly.>
- 2) Prepare the transmission for overhaul. <Ref. to 6MT-38, Preparation for Overhaul.>
- 3) Remove the neutral position switch, back-up light switch and harness. <Ref. to 6MT-42, REMOVAL, Neutral Position Switch.> <Ref. to 6MT-40, REMOVAL, Back-up Light Switch.>
- 4) Remove the extension case. <Ref. to 6MT-44, REMOVAL, Extension Case.>
- 5) Remove the transfer driven gear. <Ref. to 6MT-56, REMOVAL, Transfer Driven Gear.>
- 6) Remove the center differential. <Ref. to 6MT-58, REMOVAL, Center Differential.>
- 7) Remove the transmission case. <Ref. to 6MT-59, REMOVAL, Transmission Case.>
- 8) Remove the driven gear assembly. <Ref. to 6MT-66, REMOVAL, Main Shaft Assembly.>
- 9) Remove the 1st needle bearing.

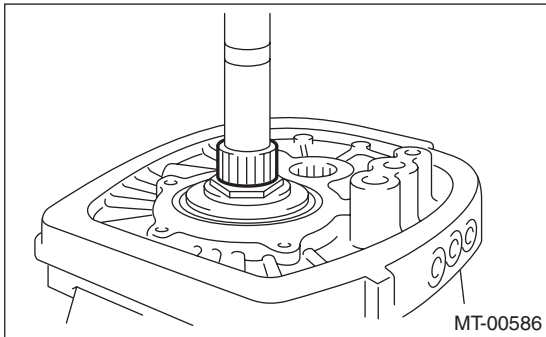

- 10) Remove the thrust needle bearing.

B: INSTALLATION

- 1) Adjust the main shaft snap ring. <Ref. to 6MT-79, ADJUSTMENT, Main Shaft Assembly.>
- 2) Adjust the 1st-2nd shifter rod. <Ref. to 6MT-115, ADJUSTMENT, Shifter Fork and Rod.>
- 3) Install the thrust needle bearing.

NOTE:

Confirm that the thrust needle bearing is installed in the proper direction.

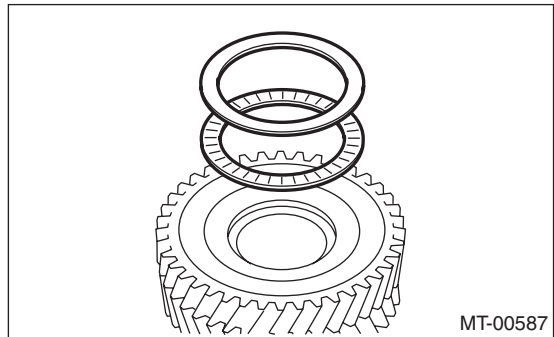

- 4) Install the 1st needle bearing.
- 5) Install the driven gear assembly. <Ref. to 6MT-67, INSTALLATION, Main Shaft Assembly.>
- 6) Install the transmission case. <Ref. to 6MT-61, INSTALLATION, Transmission Case.>
- 7) Adjust the backlash of the driven gear assembly in the axial direction. <Ref. to 6MT-89, ADJUSTMENT, Driven Gear Assembly.>
- 8) Install the center differential. <Ref. to 6MT-58, INSTALLATION, Center Differential.>
- 9) Install the transfer driven gear. <Ref. to 6MT-56, INSTALLATION, Transfer Driven Gear.>
- 10) Install the extension case. <Ref. to 6MT-44, INSTALLATION, Extension Case.>
- 11) Install the neutral position switch, back-up light switch and harness. <Ref. to 6MT-42, INSTALLATION, Neutral Position Switch.> <Ref. to 6MT-40, INSTALLATION, Back-up Light Switch.>
- 12) Install the manual transmission assembly to the vehicle. <Ref. to 6MT-34, INSTALLATION, Manual Transmission Assembly.>

Driven Gear Assembly

MANUAL TRANSMISSION AND DIFFERENTIAL

Brought to you by Eris Studios
NOT FOR RESALE

C: DISASSEMBLY

NOTE:

Individual sleeves and hubs meet at a specified position. Before disassembly, mark the meeting position of the sleeve and hub.

1) Affix the ST to the work table.

ST 18664AA000 BASE

2) Flatten the locknut tab.

3) Attach ST3 to the lock nut, set the driven gear assembly to the ST, and remove the lock nut and washer.

ST1 18666AA000 HOLDER

ST2 18664AA000 BASE

ST3 18620AA000 ADAPTER WRENCH

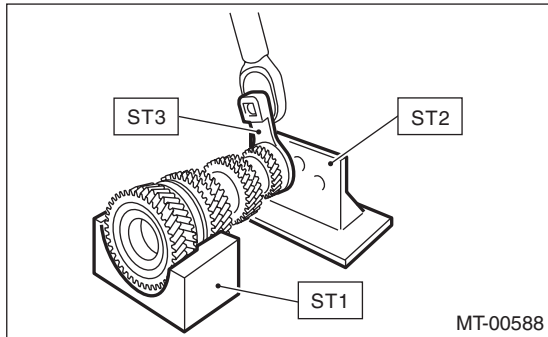

MT-00588

4) Attach ST1 to the 6th gear, then remove the ball bearing and 5th-6th driven gear.

ST1 18723AA000 REMOVER

ST2 499877000 RACE 4-5 INSTALLER

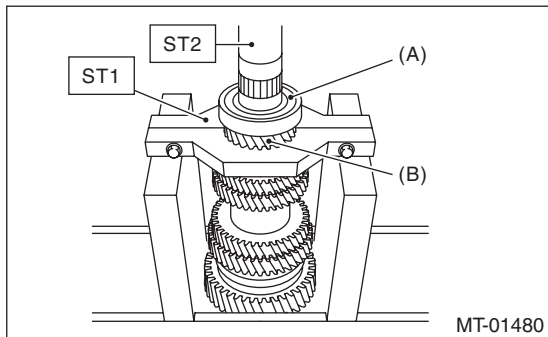

MT-01480

(A) Ball bearing

(B) 5th-6th driven gear

5) Attach ST1 to the 4th gear, then remove the 3rd-4th driven gear.

ST1 18723AA000 REMOVER

ST2 499877000 RACE 4-5 INSTALLER

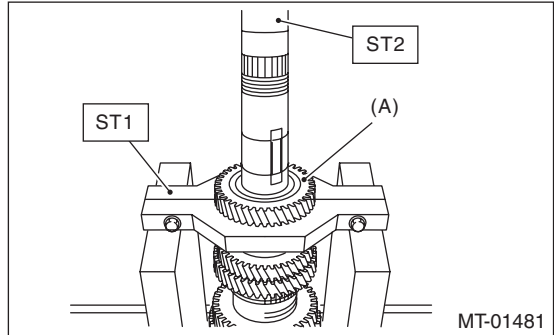

MT-01481

(A) 3rd-4th driven gear

6) Remove the driven gear key.

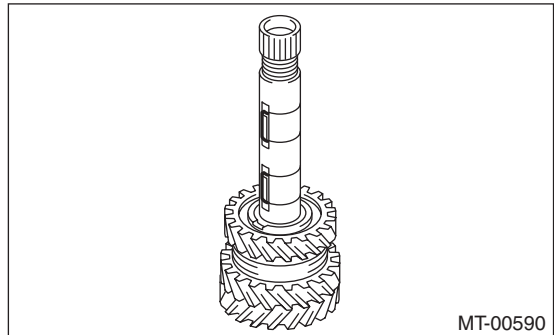

MT-00590

7) Remove the 2nd gear.

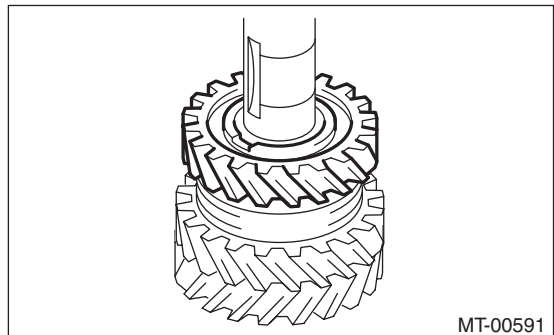

MT-00591

8) Remove the needle bearing and 1st-2nd sleeve.

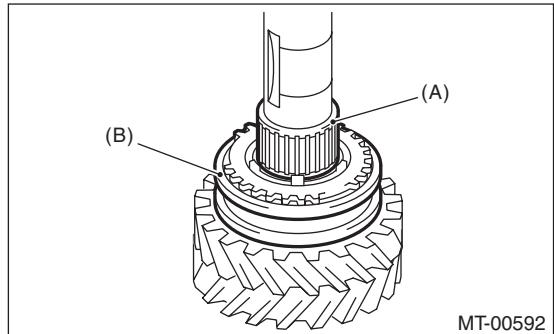

MT-00592

(A) Needle bearing

(B) 1st-2nd sleeve

Driven Gear Assembly

MANUAL TRANSMISSION AND DIFFERENTIAL

Brought to you by
NOVA
SALES
Peris Studios

9) Remove the outer baulk ring, 2nd synchro cone and inner baulk ring.

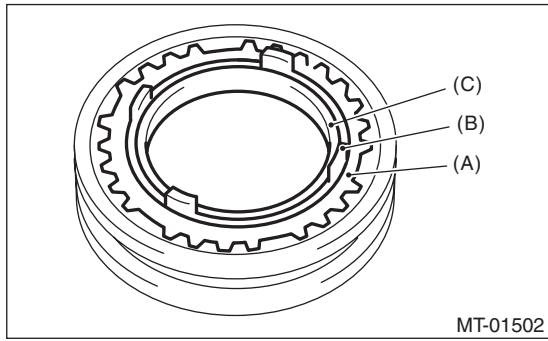

- (A) Outer baulk ring
- (B) 2nd synchro cone
- (C) Inner baulk ring

10) Using the ST, remove individual parts.
ST 18754AA000 REMOVER

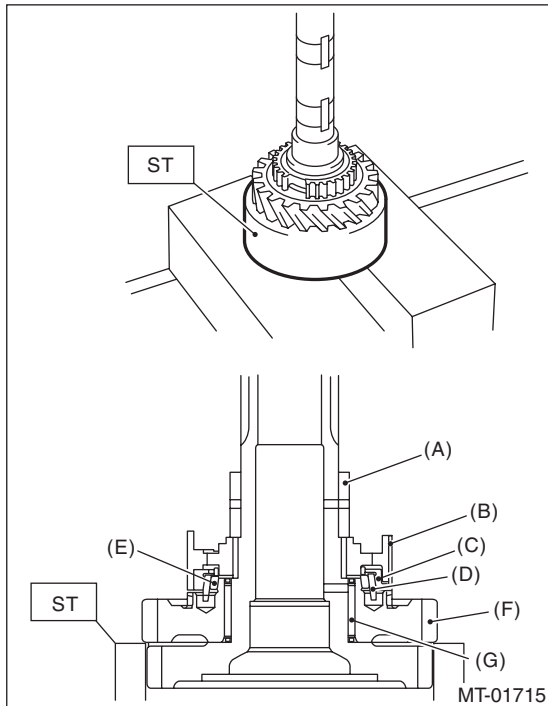

- (A) 2nd bushing
- (B) 1st-2nd hub
- (C) Outer baulk ring
- (D) 1st synchro cone
- (E) Inner baulk ring
- (F) 1st driven gear
- (G) 1st needle bearing

D: ASSEMBLY

NOTE:

When replacing the following parts, replace as a set.

- Sleeve and hub
- Outer baulk ring, 1st synchro cone and inner baulk ring
- Outer baulk ring, 2nd synchro cone and inner baulk ring

1) Apply adequate transmission gear oil to the main shaft, 1st needle bearing and 1st drive gear inner surface.

2) Install the 1st needle bearing.

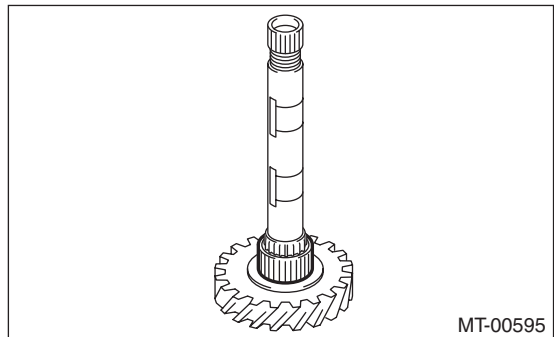

3) Attach the 1st driven gear to the driven shaft.

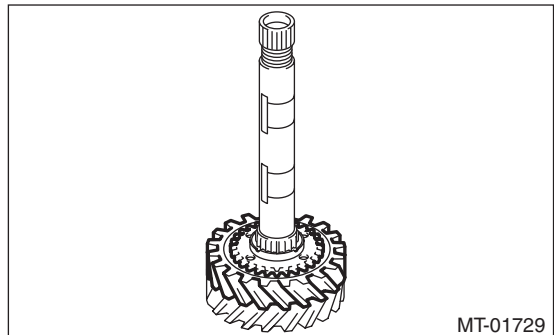

4) Install the inner baulk ring.

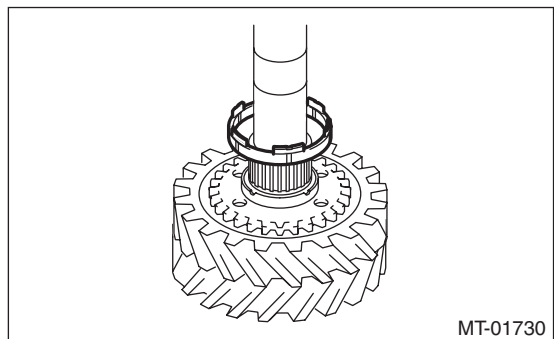

Driven Gear Assembly

MANUAL TRANSMISSION AND DIFFERENTIAL

Brought to you by Eris Studios
NOT FOR RESALE

5) Match the protrusion of the 1st synchro cone to the hole of the 1st drive gear, then install.

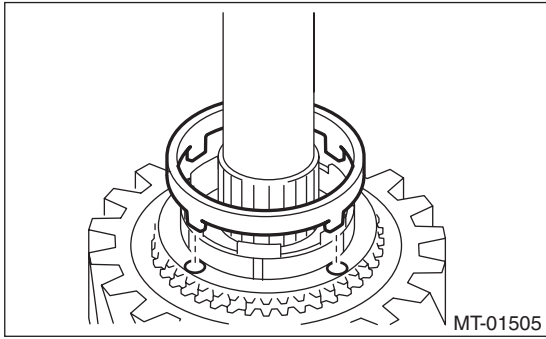

6) Install the outer baulk ring.

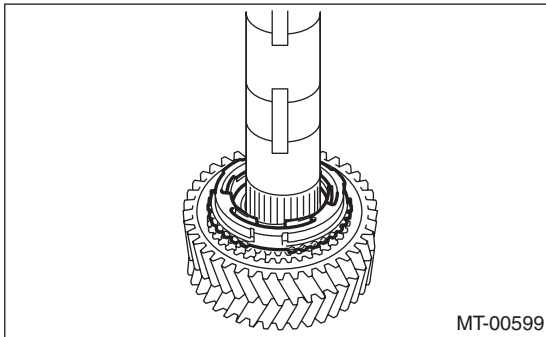

7) Install the 1st-2nd hub.

NOTE:

- Match the cut out of the 1st-2nd hub with the protrusion on the outer baulk ring, then install.
- Make sure that the 1st-2nd hub is installed in the correct direction.

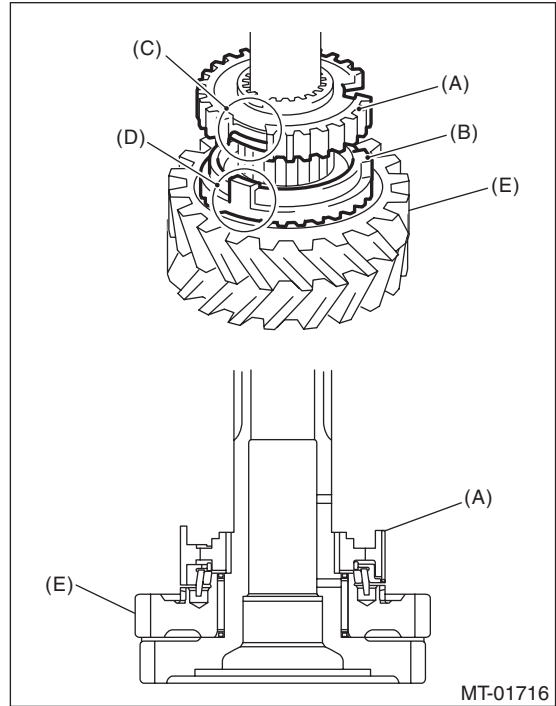

- (A) 1st-2nd hub
- (B) Outer baulk ring
- (C) 1st-2nd hub cut out section
- (D) Protrusion of the outer baulk ring
- (E) 1st driven gear

8) Using the ST, install the 1st-2nd hub and 2nd bush.

ST 18654AA000 INSTALLER

CAUTION:

Do not apply pressure in excess of 40 kN (4.0 ton, 4.4 US ton, 3.9 Imp ton).

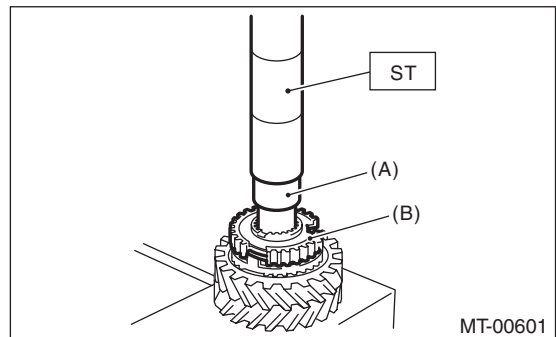

- (A) 2nd bushing
- (B) 1st-2nd hub

Driven Gear Assembly

MANUAL TRANSMISSION AND DIFFERENTIAL

Brought to you by
NOT FOR SALE
Peris Studios

9) Make sure that the 1st driven gear can be turned smoothly by hand. If it does not turn smoothly, re-assemble.

10) Attach the 1st-2nd sleeve to the 1st-2nd hub.

NOTE:

- Make sure that the 1st-2nd sleeve is installed in the correct direction.
- Align the 1st-2nd hub cut out section (three places) and the key grooves (three places) of shifting insert key that are located inside the 1st-2nd sleeve.
- Set the 1st-2nd sleeve and 1st driven gear so that they contact each other.

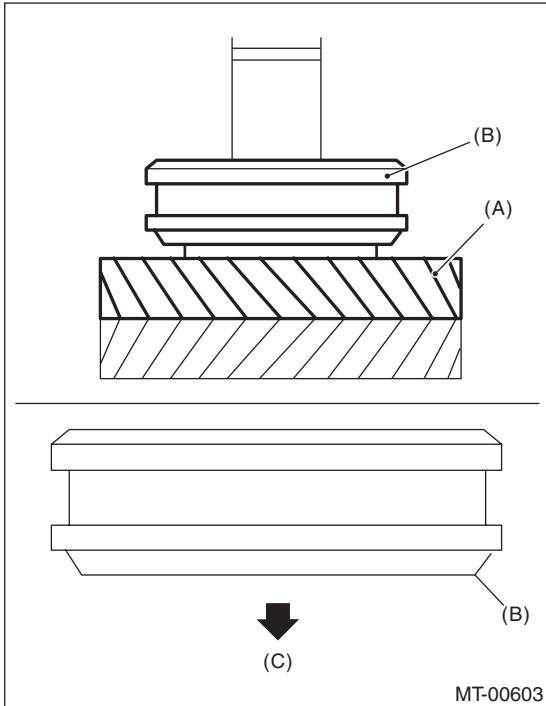

- (A) 1st driven gear
- (B) 1st-2nd sleeve
- (C) 1st driven gear side

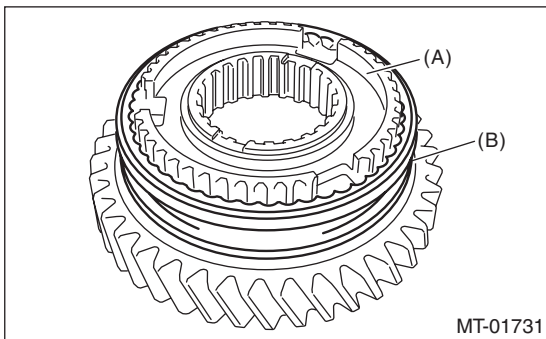

- (A) 1st-2nd hub
- (B) 1st-2nd sleeve

11) Attach the shifting insert key to the appropriate position of the 1st-2nd sleeve.

NOTE:

- The location angle of each shifting insert key is 120°.
- Install the shifting insert key to the key grooves (three places) of shifting insert key that are located inside the 1st-2nd sleeve.

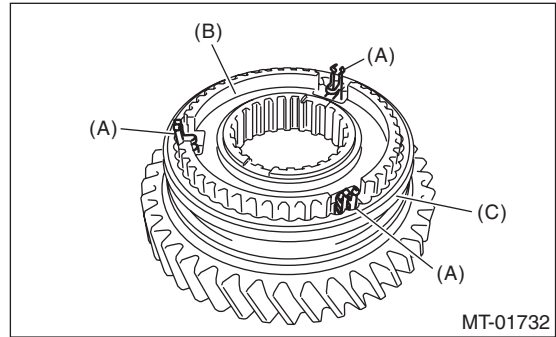

- (A) Shifting insert key
- (B) 1st-2nd hub
- (C) 1st-2nd sleeve

12) Install the outer baulk ring.

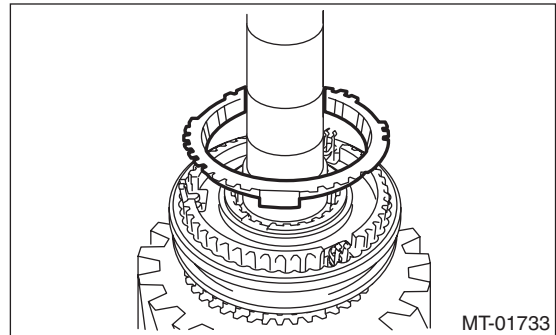

13) Install the 2nd synchro cone.

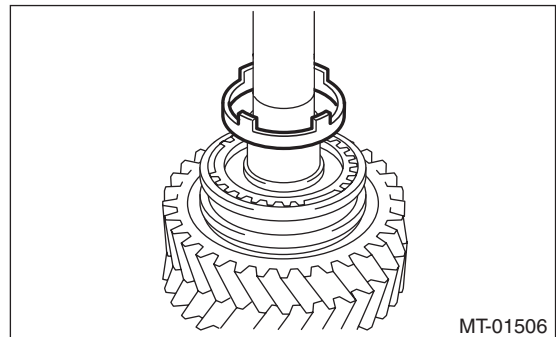

Driven Gear Assembly

MANUAL TRANSMISSION AND DIFFERENTIAL

Brought to you by Eris Studios
NOT FOR RESALE

14) Install the inner baulk ring.

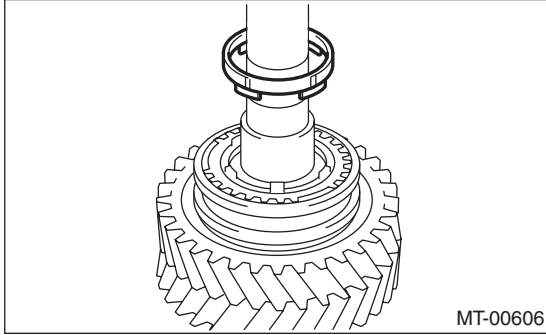

15) Apply adequate transmission gear oil to the bushing, 2nd needle bearing and 2nd drive gear inner surface.

16) Install the 2nd needle bearing and 2nd driven gear.

NOTE:

Match the protrusion of the 2nd synchro cone to the hole of the 2nd driven gear, then install.

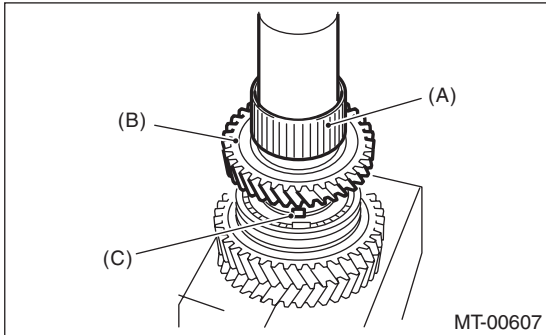

- (A) 2nd needle bearing
- (B) 2nd driven gear
- (C) Protrusion of the 2nd synchro cone

17) Attach the key.

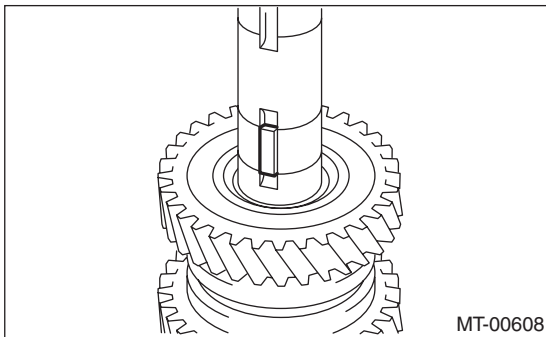

18) Using the ST, install the 3rd-4th driven gear.
ST 18654AA000 INSTALLER

CAUTION:

Do not apply pressure in excess of 40 kN (4.0 ton, 4.4 US ton, 3.9 Imp ton).

NOTE:

- Make sure that the 3rd-4th driven gear is installed in the correct direction.
- Match the groove on the 3rd-4th driven gear to the key.

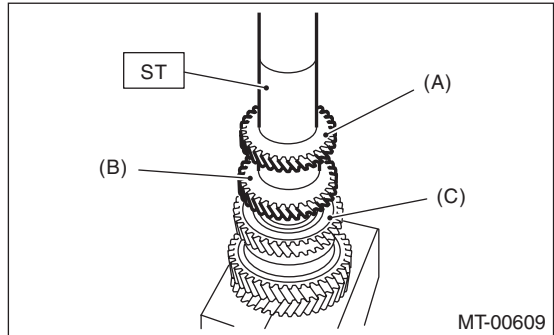

- (A) 4th gear
- (B) 3rd gear
- (C) 2nd gear

19) Make sure that the 2nd driven gear can be turned smoothly by hand. If it does not turn smoothly, reassemble.

20) Attach the key.

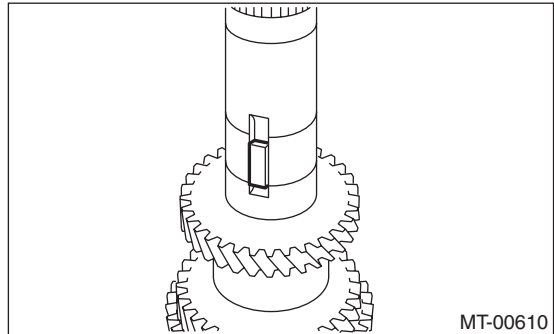

Driven Gear Assembly

MANUAL TRANSMISSION AND DIFFERENTIAL

Brought to you by
NOT FOR SALE
Peris Studios

21) Using the ST, install the 5th-6th driven gear.
ST 18654AA000 INSTALLER

CAUTION:

Do not apply pressure in excess of 40 kN (4.0 ton, 4.4 US ton, 3.9 Imp ton).

NOTE:

- Make sure that the 5th-6th driven gear is installed in the correct direction.
- Match the groove on the 5th-6th driven gear to the key.

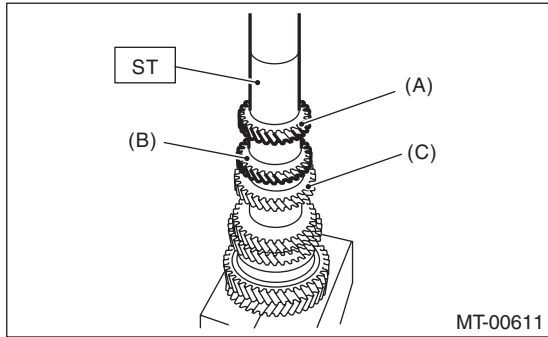

- (A) 6th gear
- (B) 5th gear
- (C) 4th gear

22) Using the ST, install the ball bearing.
ST 18654AA000 INSTALLER

CAUTION:

Do not apply pressure in excess of 40 kN (4.0 ton, 4.4 US ton, 3.9 Imp ton).

NOTE:

Confirm that the ball bearing is installed in the proper direction.

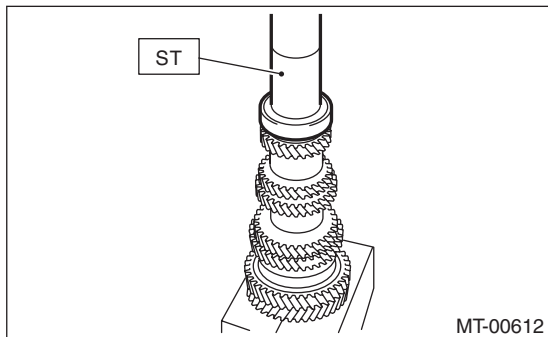

23) Make sure that the ball bearing turns smoothly by hand. If it does not turn smoothly, reassemble.
24) Install a new lock nut.

25) Attach ST3 to the lock nut, attach ST to the driven gear assembly, and tighten the lock nut.

- ST1 18666AA000 HOLDER
- ST2 18664AA000 BASE
- ST3 18620AA000 ADAPTER WRENCH
- ST4 18852AA000 TORQUE WRENCH

Tightening torque:

530 N·m (54.0 kgf·m, 390.9 ft·lb)

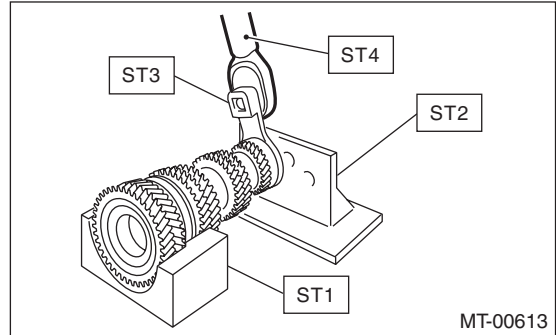

NOTE:

When using a torque wrench other than ST4, use the calculation below to calculate and tighten the lock nut.

$$T = L1 / (0.1 + L1) \times 570$$

T	N·m (kgf·m, ft·lb)	Torque wrench setting
L1	m (in)	Torque wrench length
	0.1 m (3.94 in)	Length of ST
570 N·m (58.1 kgf·m, 420 ft·lb)		Tightening torque (lock nut):

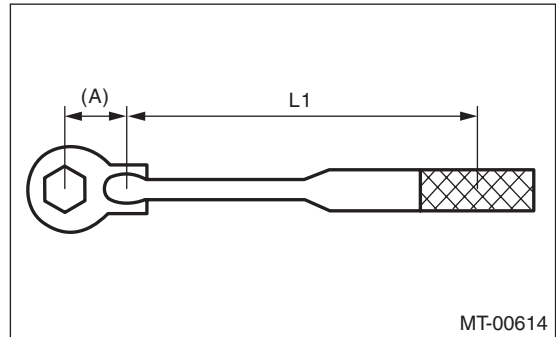

(A) 0.1 m (3.94 in)

Driven Gear Assembly

MANUAL TRANSMISSION AND DIFFERENTIAL

26) Using the ST, crimp the lock nut in 4 locations, with dimensions within $A 44 \pm 0.5$ mm (1.73 ± 0.02 in).

ST 18669AA000 PUNCH DRIVEN SHAFT

NOTE:

Do not damage the crimp area of the lock nut.

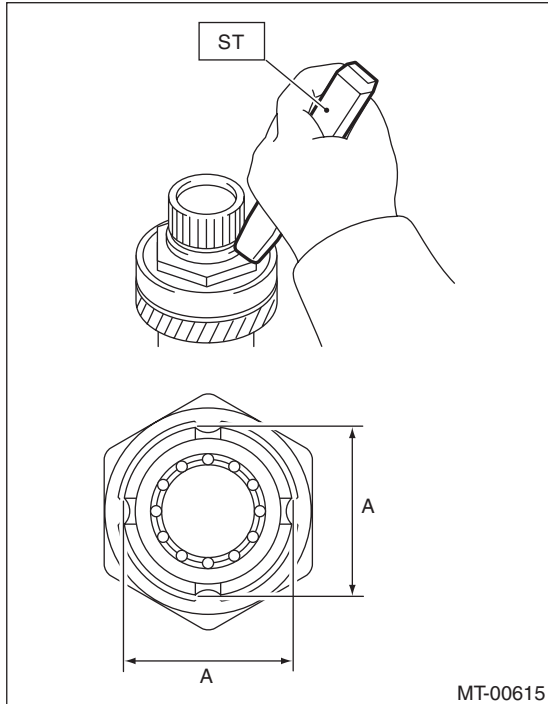

E: INSPECTION

Disassembled parts should be washed clean first with cleaning solvent and then inspected carefully.

1) Bearing

Replace the bearings in the following cases.

- Wear, rusting or damage of the bearings
- The bearing does not rotate smoothly or an abnormal noise is emitted when turning.
- When the bearing has other defects

2) Bushing (each gear)

Replace the bushing in following cases.

- The sliding surface is damaged or abnormally worn.

3) Gear

Replace gears in the following cases.

- The gear teeth surface is damaged or excessively worn.
- If the contact area of the baulk ring is damaged.
- If the inner face of the gear is worn.

4) Baulk ring, synchro cone

Replace the baulk ring and synchro cone in following cases:

- Wear, rusting or damage of the baulk ring

5) Shifting insert key

Replace the shifting insert key if deformed, excessively worn or defective in any way.

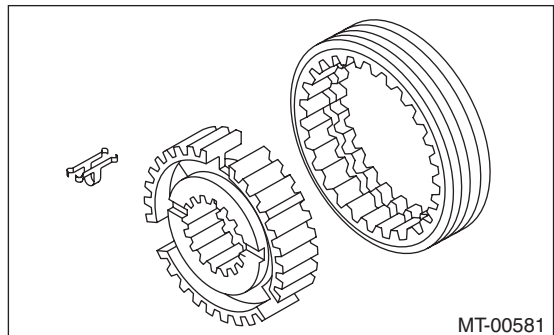

F: ADJUSTMENT

1) Measure the length “H” from the transmission case and transfer bearing holder mating surface, to the end face of the ball bearing.

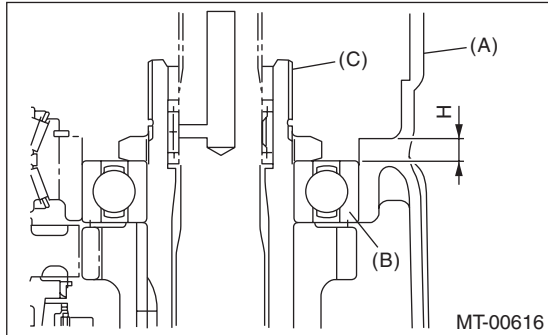

- (A) Transmission case
- (B) Ball bearing
- (C) Driven gear ASSY

2) Using the following calculation, calculate the thickness of the driven gear assembly washer.

$$T = H - \{5.8 \pm 0.05 \text{ mm (} 0.23 \pm 0.002 \text{ in)}\}$$

$$- \{0.1 - 0.3 \text{ mm (} 0.0039 - 0.0118 \text{ in)}\}$$

t	Washer thickness
H	Length from the transmission case and transfer bearing holder mating surface to the end face of the ball bearing
5.8±0.05 mm (0.23±0.002 in)	Collar thickness
0.1 — 0.3 mm (0.0039 — 0.0118 in)	Driven gear assembly axial direction backlash standard

3) Select 0 to 3 washers from the following table, and adjust to the backlash that is closest to the standard value.

Driven gear assembly axial direction backlash standard:

0.1 — 0.3 mm (0.0039 — 0.0118 in)

Washer	
Part No.	Thickness t mm (in)
803072030	0.15 (0.0059)
803072031	0.30 (0.0118)
803072032	0.45 (0.0177)
803072033	0.60 (0.0236)

Reverse Idler Gear Assembly

MANUAL TRANSMISSION AND DIFFERENTIAL

Brought to you by Eris Studios
NOT FOR RESALE

19. Reverse Idler Gear Assembly

A: REMOVAL

- 1) Remove the manual transmission assembly from the vehicle. <Ref. to 6MT-32, REMOVAL, Manual Transmission Assembly.>
- 2) Prepare the transmission for overhaul. <Ref. to 6MT-38, Preparation for Overhaul.>
- 3) Remove the neutral position switch, back-up light switch and harness. <Ref. to 6MT-42, REMOVAL, Neutral Position Switch.> <Ref. to 6MT-40, REMOVAL, Back-up Light Switch.>
- 4) Remove the extension case. <Ref. to 6MT-44, REMOVAL, Extension Case.>
- 5) Remove the transfer driven gear. <Ref. to 6MT-56, REMOVAL, Transfer Driven Gear.>
- 6) Remove the center differential. <Ref. to 6MT-58, REMOVAL, Center Differential.>
- 7) Remove the transmission case. <Ref. to 6MT-59, REMOVAL, Transmission Case.>
- 8) Remove the reverse idler gear assembly. <Ref. to 6MT-66, REMOVAL, Main Shaft Assembly.>

B: INSTALLATION

- 1) Select the reverse fork rod. <Ref. to 6MT-115, ADJUSTMENT, Shifter Fork and Rod.>
- 2) Install the reverse idler gear assembly. <Ref. to 6MT-67, INSTALLATION, Main Shaft Assembly.>
- 3) Install the transmission case. <Ref. to 6MT-61, INSTALLATION, Transmission Case.>
- 4) Install the center differential. <Ref. to 6MT-58, INSTALLATION, Center Differential.>
- 5) Install the transfer driven gear. <Ref. to 6MT-56, INSTALLATION, Transfer Driven Gear.>
- 6) Install the extension case. <Ref. to 6MT-44, INSTALLATION, Extension Case.>
- 7) Install the neutral position switch, back-up light switch and harness. <Ref. to 6MT-42, INSTALLATION, Neutral Position Switch.> <Ref. to 6MT-40, INSTALLATION, Back-up Light Switch.>
- 8) Install the manual transmission assembly to the vehicle. <Ref. to 6MT-34, INSTALLATION, Manual Transmission Assembly.>

C: DISASSEMBLY

NOTE:

Sleeves and reverse gears meet at a specified position. Before disassembly, mark the meeting position of the sleeve and hub.

- 1) Remove the spring pin.

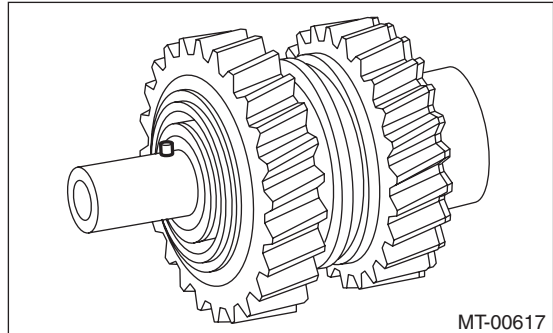

- 2) Remove the snap ring and washer.

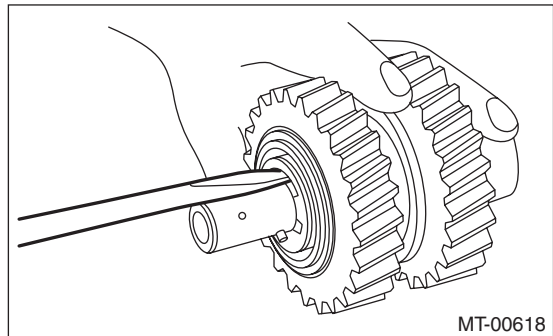

- 3) Remove the counter high & low washer and reverse idler gear.

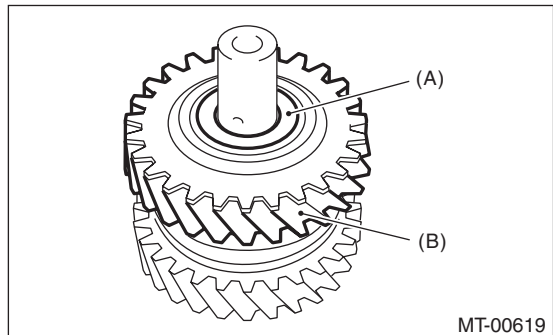

- (A) Counter high & low washer
(B) Reverse idler gear

Reverse Idler Gear Assembly

MANUAL TRANSMISSION AND DIFFERENTIAL

Brought to you by
NOVA
SALE
Meris Studios

4) Remove the knock pin and reverse idler gear needle bearing.

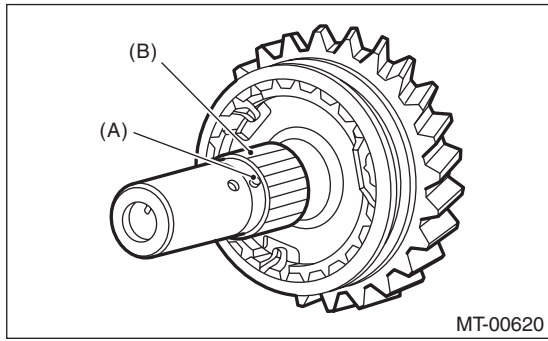

- (A) Knock pin
- (B) Reverse idler gear needle bearing

5) Remove the collar.

6) Remove the reverse sleeve.

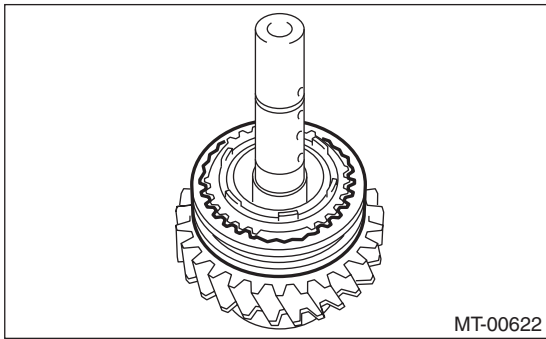

7) Remove the outer baulk ring, reverse synchro cone and inner baulk ring from the reverse sleeve.

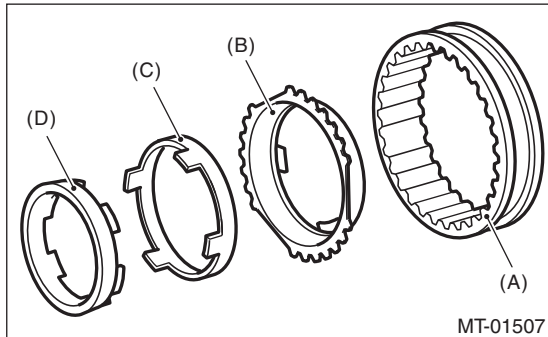

- (A) Reverse sleeve
- (B) Outer baulk ring
- (C) Reverse synchro cone
- (D) Inner baulk ring

8) Remove reverse idler gear No. 2.

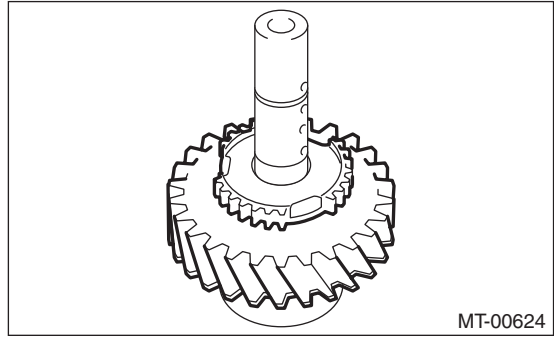

9) Remove the counter high & low washer and needle bearing.

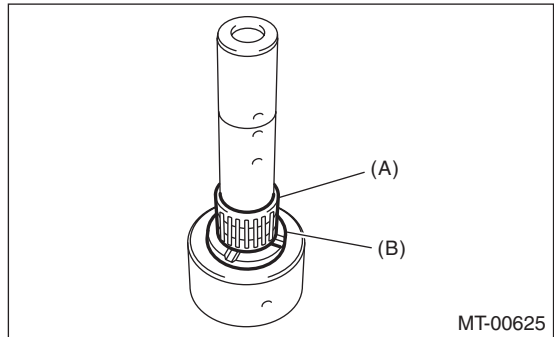

- (A) Needle bearing
- (B) Counter high & low washer

10) Remove the knock pin.

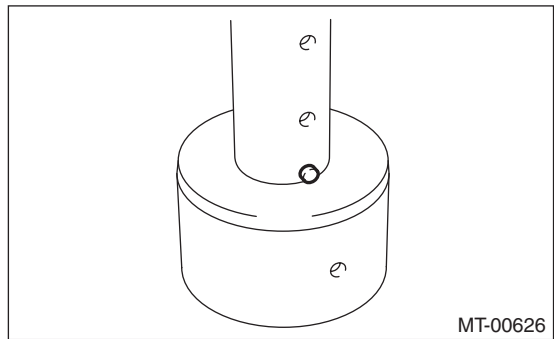

11) Remove the snap ring and friction plate from reverse gear.

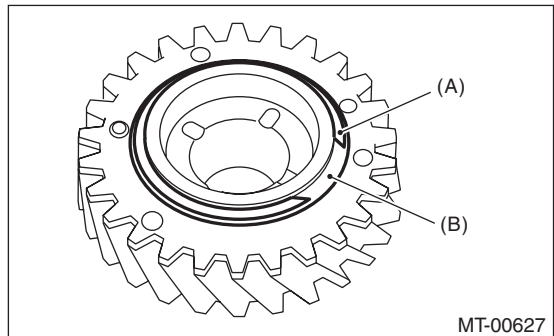

- (A) Snap ring
- (B) Friction plate

Reverse Idler Gear Assembly

MANUAL TRANSMISSION AND DIFFERENTIAL

Brought to you by Eris Studios
NOT FOR RESALE

1) Remove the sub gear and spring.

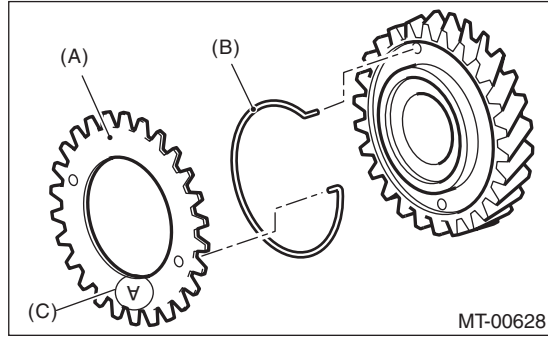

- (A) Sub gear
- (B) Spring
- (C) Stamp (Marking A)

D: ASSEMBLY

1) Attach the sub gear and spring.

NOTE:

- Turn the white marking on the hook section towards the sub gear side, and attach the spring.
- Point the stamp (marking A) towards the outside, and install the sub gear.

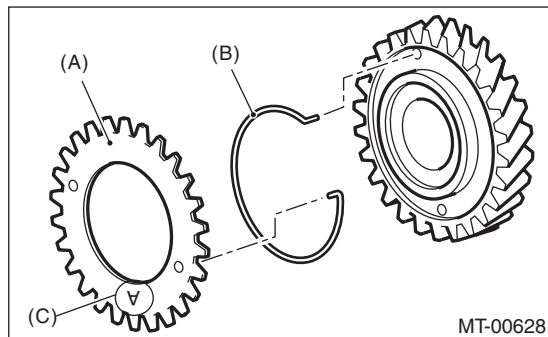

- (A) Sub gear
- (B) Spring
- (C) Stamp (Marking A)

- While paying attention to the direction of the sub gear attachment hole, attach the spring and sub gear.

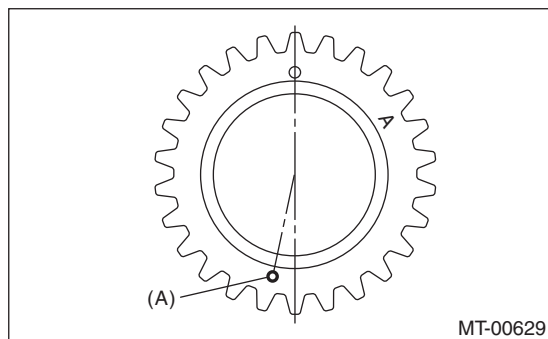

- (A) Attachment hole

2) Install the friction plate and snap ring.

NOTE:

Confirm that the friction plate is installed in the proper direction.

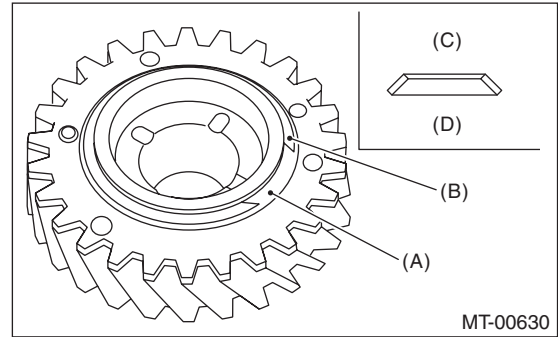

- (A) Friction plate
- (B) Snap ring
- (C) Snap ring side
- (D) Sub gear side

3) Apply adequate transmission gear oil to the shaft, needle bearing and reverse drive gear inner surface.

4) Install the knock pin.

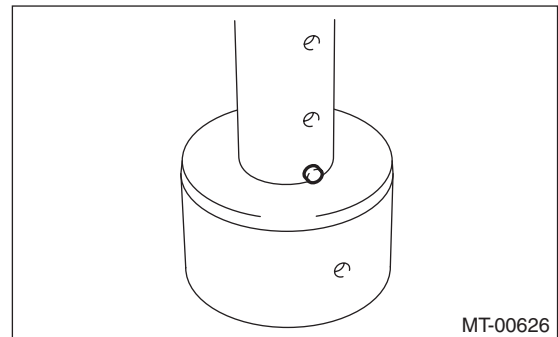

5) Install the counter high & low washer and needle bearing.

NOTE:

Point the groove towards the reverse idler gear, and attach the washer.

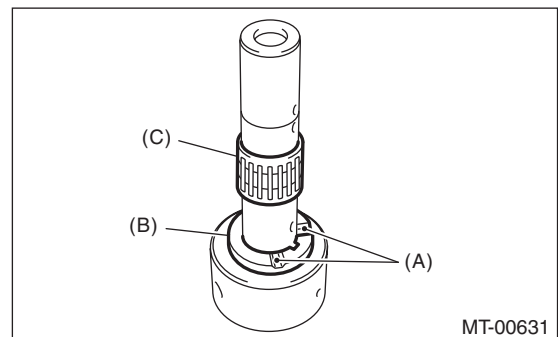

- (A) Groove
- (B) Counter high & low washer
- (C) Needle bearing

Reverse Idler Gear Assembly

MANUAL TRANSMISSION AND DIFFERENTIAL

Brought to you by
NOT FOR SALE
Peris Studios

6) Install the reverse idler gear No. 2.

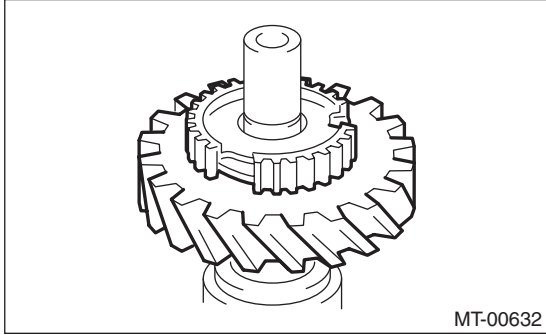

7) Attach the shifting insert key to the appropriate location of the reverse sleeve.

NOTE:

- The location angle of each shifting insert key is 120°.
- Refer to the following figure to install the shifting insert key.

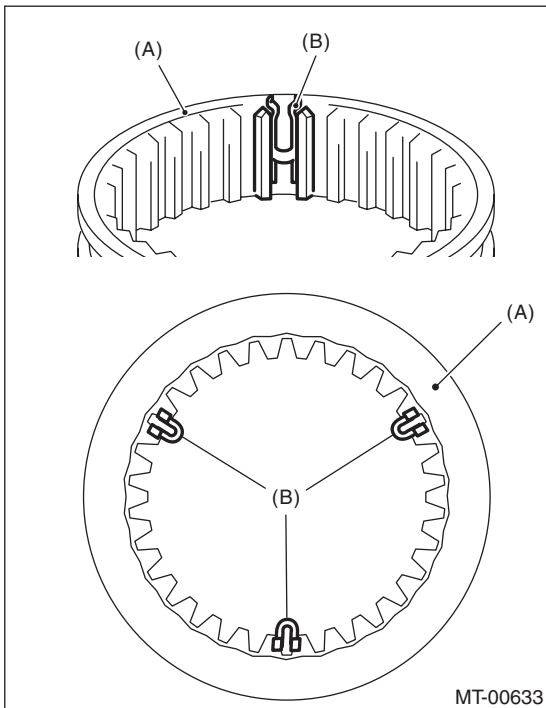

- (A) Reverse sleeve
- (B) Shifting insert key

8) Attach the reverse sleeve to the reverse idler gear No. 2.

NOTE:

Confirm that the reverse sleeve is installed in the proper direction.

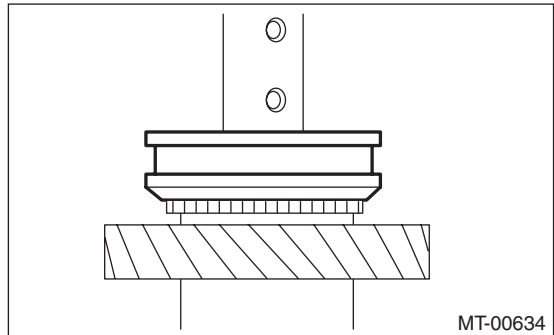

9) Apply adequate transmission gear oil to the collar, needle bearing and reverse drive gear inner surface.

10) Install the outer baulk ring, reverse synchro cone and inner baulk ring.

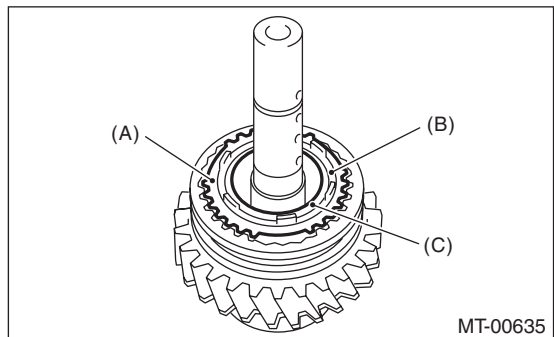

- (A) Outer baulk ring
- (B) Reverse synchro cone
- (C) Inner baulk ring

11) Install the collar and needle bearing, then the knock pin.

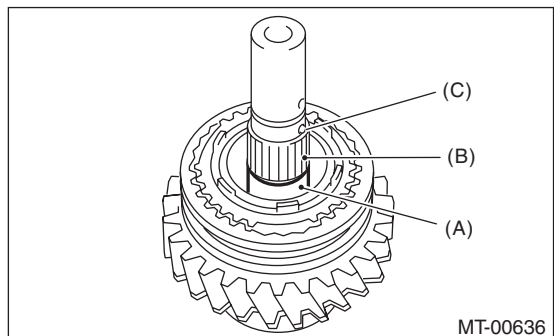

- (A) Collar
- (B) Needle bearing
- (C) Knock pin

Reverse Idler Gear Assembly

MANUAL TRANSMISSION AND DIFFERENTIAL

Brought to you by Eris Studios
NOT FOR RESALE

12) Match the protrusion of the reverse synchro cone to the hole on the reverse idler gear, and install the reverse idler gear.

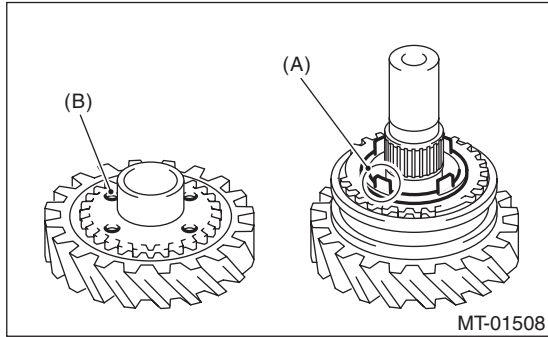

(A) Protrusion on the reverse synchro cone
(B) Hole of the reverse idler gear

13) Point the groove towards the reverse idler gear, and attach the counter high & low washer and the washer.

14) Using the ST, install the snap ring.
ST 18672AA000 GUIDE CLIP

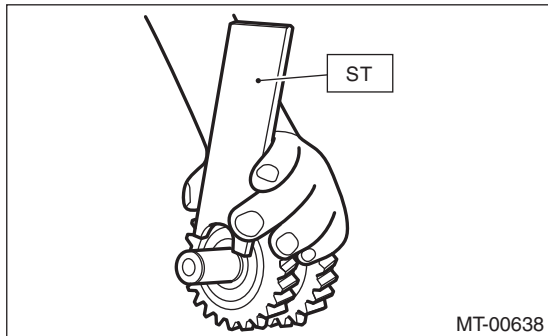

MT-00638

15) Inspect and adjust the clearance between the snap ring and the washer. <Ref. to 6MT-94, INSPECTION, Reverse Idler Gear Assembly.>

16) Install a new spring pin.

E: INSPECTION

Disassembled parts should be washed clean first with cleaning solvent and then inspected carefully.

1) Bearing

Replace the bearings in the following cases.

- Wear, rusting or damage of the bearings
- The bearing does not rotate smoothly or an abnormal noise is emitted when turning.
- When the bearing has other defects

2) Bushing (each gear)

Replace the bushing in following cases.

- The sliding surface is damaged or abnormally worn.

3) Gear

Replace gears in the following cases.

- The gear teeth surface is damaged or excessively worn.
- If the contact area of the baulk ring is damaged.
- If the inner face of the gear is worn.

4) Baulk ring, synchro cone

Replace the baulk ring and synchro cone in following cases:

- Wear, rusting or damage of the baulk ring

5) Shifting insert key

Replace the shifting insert key if deformed, excessively worn or defective in any way.

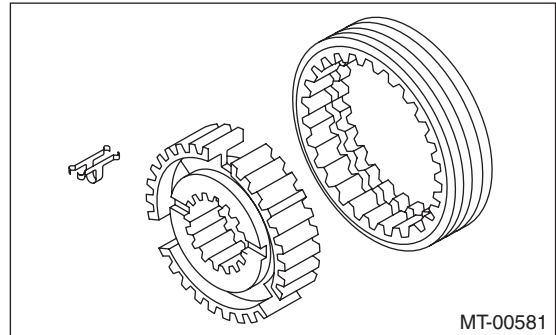

MT-00581

6) Check clearance between the snap ring and washer.

Clearance specification:

0.1 — 0.3 mm (0.0039 — 0.0118 in)

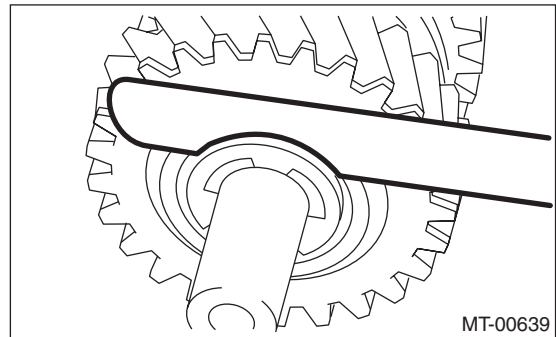

MT-00639

If the clearance is out of the specification, select a snap ring from the following table and perform replacement.

Snap ring	
Part No.	Thickness mm (in)
031319000	1.50 (0.059)
805019030	1.60 (0.062)
805019010	1.72 (0.068)

After replacing the snap ring, inspect the clearance.

20. Drive Pinion Shaft Assembly

A: REMOVAL

- 1) Remove the manual transmission assembly from the vehicle. <Ref. to 6MT-32, REMOVAL, Manual Transmission Assembly.>
- 2) Prepare the transmission for overhaul. <Ref. to 6MT-38, Preparation for Overhaul.>
- 3) Remove the neutral position switch, back-up light switch and harness. <Ref. to 6MT-42, REMOVAL, Neutral Position Switch.> <Ref. to 6MT-40, REMOVAL, Back-up Light Switch.>
- 4) Remove the extension case. <Ref. to 6MT-44, REMOVAL, Extension Case.>
- 5) Remove the transfer driven gear. <Ref. to 6MT-56, REMOVAL, Transfer Driven Gear.>
- 6) Remove the center differential. <Ref. to 6MT-58, REMOVAL, Center Differential.>
- 7) Remove the transmission case. <Ref. to 6MT-59, REMOVAL, Transmission Case.>
- 8) Remove the individual gear assemblies. <Ref. to 6MT-66, REMOVAL, Main Shaft Assembly.>
- 9) Remove the drive pinion shaft assembly.

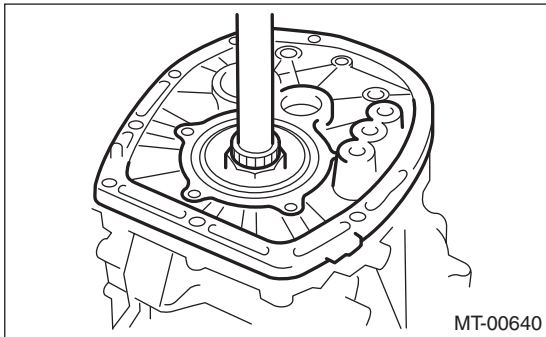

B: INSTALLATION

- 1) Remove any remaining gasket material from the drive plate and clutch housing.
- 2) Apply liquid gasket to the clutch housing.

Liquid gasket:

THREE BOND 1215 (Part No. 004403007) or equivalent

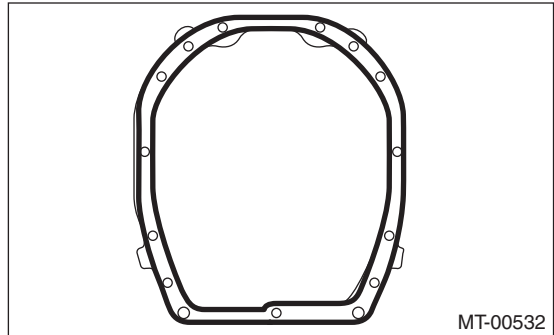

- 3) Install the individual gear assemblies. <Ref. to 6MT-67, INSTALLATION, Main Shaft Assembly.>
- 4) Install the transmission case. <Ref. to 6MT-61, INSTALLATION, Transmission Case.>
- 5) Install the center differential. <Ref. to 6MT-58, INSTALLATION, Center Differential.>
- 6) Install the transfer driven gear. <Ref. to 6MT-56, INSTALLATION, Transfer Driven Gear.>
- 7) Install the extension case. <Ref. to 6MT-44, INSTALLATION, Extension Case.>
- 8) Install the neutral position switch, back-up light switch and harness. <Ref. to 6MT-42, INSTALLATION, Neutral Position Switch.> <Ref. to 6MT-40, INSTALLATION, Back-up Light Switch.>
- 9) Install the manual transmission assembly to the vehicle. <Ref. to 6MT-34, INSTALLATION, Manual Transmission Assembly.>

Drive Pinion Shaft Assembly

MANUAL TRANSMISSION AND DIFFERENTIAL

Brought to you by Eris Studios
NOT FOR RESALE

C: DISASSEMBLY

NOTE:

Replace the drive pinion shaft and the hypoid driven gear as a set.

1) Remove the oil guide A.

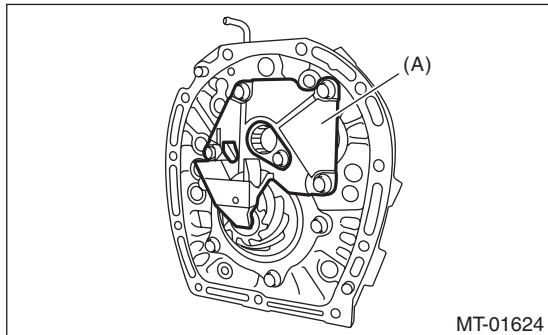

(A) Oil guide A

2) Remove the drive pinion shaft and shim from the adapter plate.

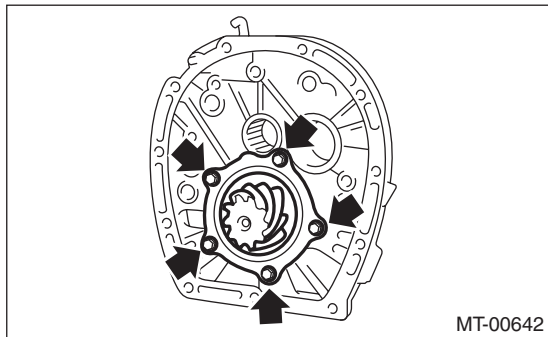

3) Affix the ST to the work table.

ST 18664AA000 BASE

4) Flatten the locknut tab.

5) Attach ST3 to the locknut, and set the drive pinion shaft to the ST. Remove the lock nut and washer.

ST1 18667AA000 HOLDER

ST2 18664AA000 BASE

ST3 18621AA000 ADAPTER WRENCH

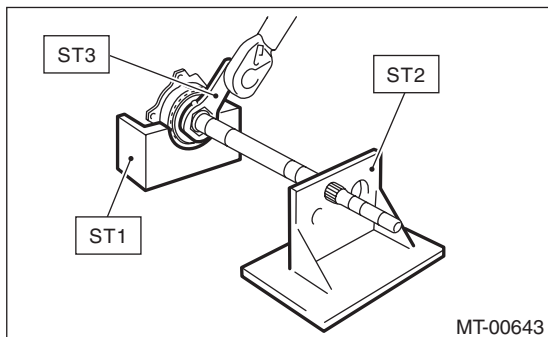

6) Using the ST, remove the taper roller bearing assembly.

ST 18723AA000 REMOVER

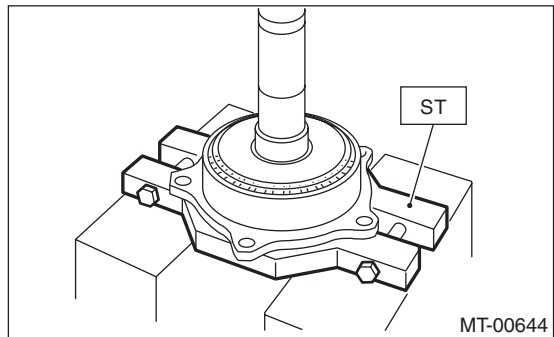

Drive Pinion Shaft Assembly

MANUAL TRANSMISSION AND DIFFERENTIAL

Brought to you by
NOT FOR SALE
Peris Studios

D: ASSEMBLY

1) Using the ST, measure drive pinion measurement "A".

NOTE:

When selecting the drive pinion shim, refer to measurement "A".

ST 398643600 GAUGE

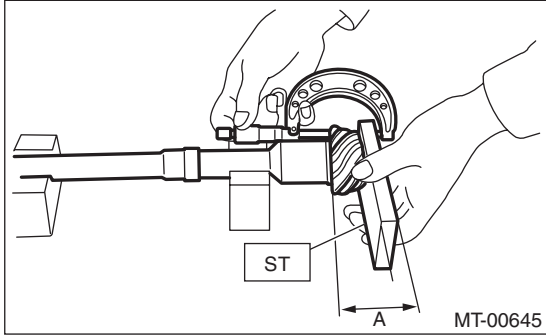

2) Using the ST and a press, attach the inner bearing of the taper roller bearing to the drive pinion shaft.

ST 18723AA000 REMOVER

CAUTION:

Do not apply pressure in excess of 40 kN (4.0 ton, 4.4 US ton, 3.9 Imp ton).

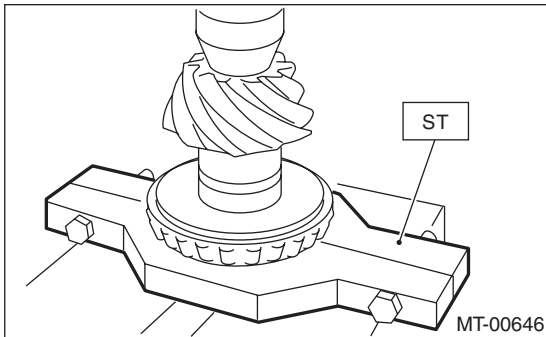

3) Using the ST and a press, attach the outer race and the taper roller bearing to the drive pinion shaft.

ST 18723AA000 REMOVER

NOTE:

Push in to a position where the bearing rotates smoothly.

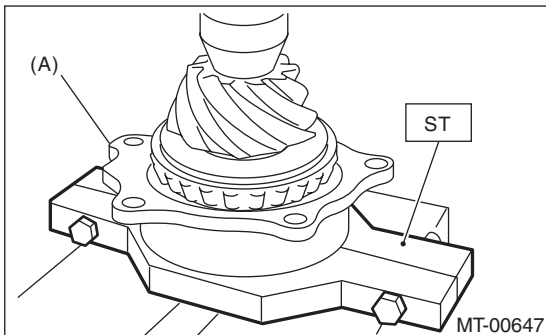

(A) Outer race

4) Attach the washer and a new lock nut.

5) Set the ST to the drive pinion, and tighten the lock nut.

ST1 18667AA000 HOLDER

ST2 18664AA000 BASE

ST3 18621AA000 ADAPTER WRENCH

ST4 18852AA000 TORQUE WRENCH

NOTE:

Tighten using the ST and the straight line torque wrench.

Tightening torque:

265 N·m (27.0 kgf·m, 195.4 ft·lb)

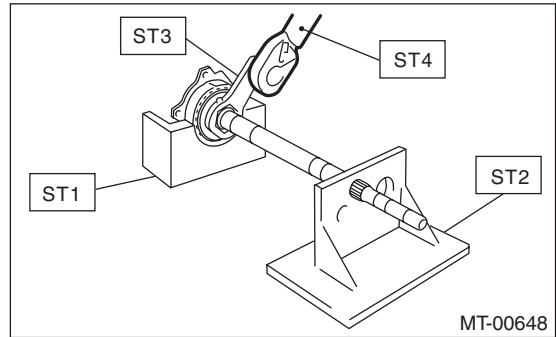

NOTE:

When using a torque wrench other than ST4, use the calculation below to calculate and tighten the lock nut.

Tighten using the ST and the straight line torque wrench.

$$T = L1 / (0.1 + L1) \times 285$$

T	N·m (kgf·m, ft·lb)	Torque wrench setting
L1	m (in)	Torque wrench length
0.1 m (3.94 in)		Length of ST
285 N·m (29.0 kgf·m, 210 ft·lb)		Tightening torque (lock nut):

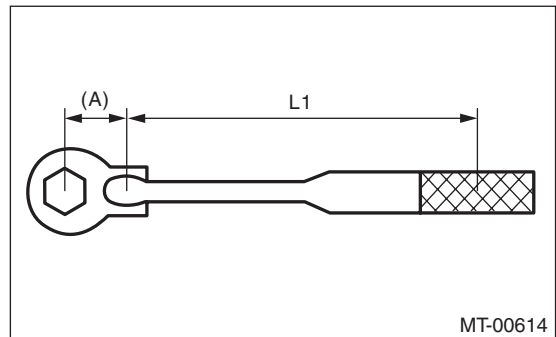

(A) 0.1 m (3.94 in)

6) Measure the starting torque. <Ref. to 6MT-99, INSPECTION, Drive Pinion Shaft Assembly.>

Drive Pinion Shaft Assembly

Brought to you by Eris Studios
NOT FOR RESALE

MANUAL TRANSMISSION AND DIFFERENTIAL

7) Using the ST, crimp the lock nut in 2 locations, with dimensions within "A" 37 ± 0.5 mm (1.46 ± 0.02 in).

ST 18670AA000 PUNCH

NOTE:

Do not damage the crimp area of the lock nut.

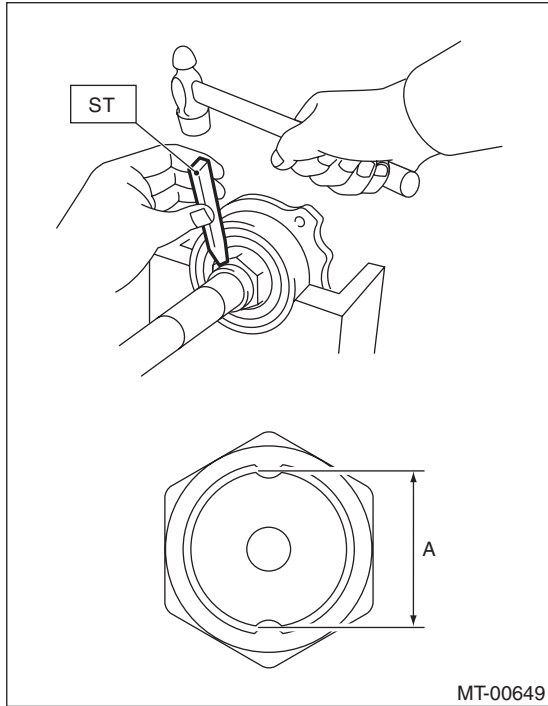

8) Using the ST, measure drive pinion measurement "B".

ST 398643600 GAUGE

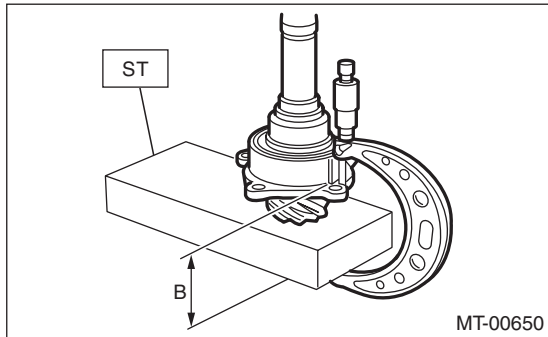

9) Calculate from the calculation below to select 1 or 2 drive pinion shims from the following table.

$$6.5\pm 0.0625 \text{ mm} - (B - A) [0.26\pm 0.0025 \text{ in} - (B - A)]$$

NOTE:

A: Measurement value in step 1)

B: Measurement value in step 8)

Drive pinion shim	
Part No.	Thickness mm (in)
32295AA270	0.15 (0.0059)
32295AA280	0.175 (0.0069)
32295AA290	0.20 (0.0079)
32295AA300	0.225 (0.0089)
32295AA310	0.25 (0.0098)
32295AA320	0.275 (0.0108)

10) Apply transmission gear oil to the side face of the taper roller bearing, and attach the drive pinion shaft and the selected shims to the adapter plate.

Tightening torque:

54 N·m (5.5 kgf·m, 39.8 ft·lb)

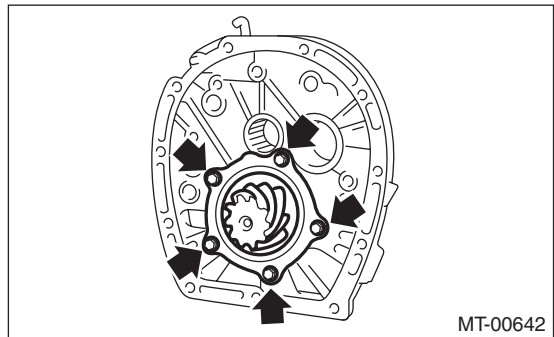

11) Install the oil guide A.

Tightening torque:

18 N·m (1.8 kgf·m, 13.3 ft·lb)

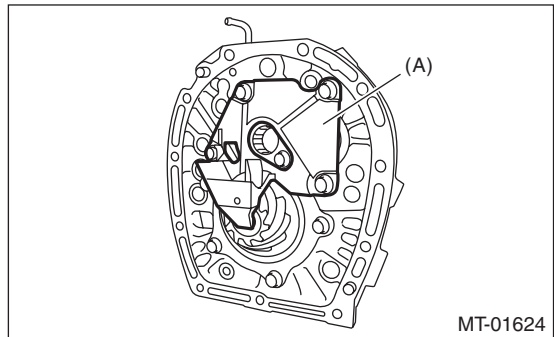

(A) Oil guide A

Drive Pinion Shaft Assembly

MANUAL TRANSMISSION AND DIFFERENTIAL

Brought to you by
NOT FOR SALE
Meris Studios

E: INSPECTION

1) Using a spring scale, measure the starting torque. If the starting torque is outside the specification range, replace the taper roller bearing.

Starting torque:

0 — 0.95 N (0 — 0.097 kgf, 0 — 0.21 lb)

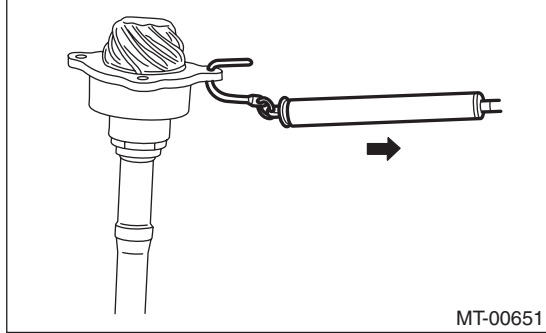

2) Gear

Replace gears in the following cases.

- The gear teeth surface is damaged or excessively worn.

3) Bearing

Replace the bearings in the following cases.

- Wear, rusting or damage of the bearings
- The bearing does not rotate smoothly or an abnormal noise is emitted when turning.

4) Adapter plate

Replace the adapter plate in the following cases:

- Wear, rusting or damage of the bearings
- Damage of the adapter plate

5) Check that the pipes and pipe chambers are not damaged or clogged. Repair or replace if damaged or clogged.

F: ADJUSTMENT

1) Inspect and adjust the hypoid driven gear-to-drive pinion backlash. <Ref. to 6MT-108, HYPOID GEAR BACKLASH, ADJUSTMENT, Front Differential Assembly.>

2) Apply a thin uniform coat of lead-free red dye on the surfaces of 3 or 4 hypoid driven gear teeth.

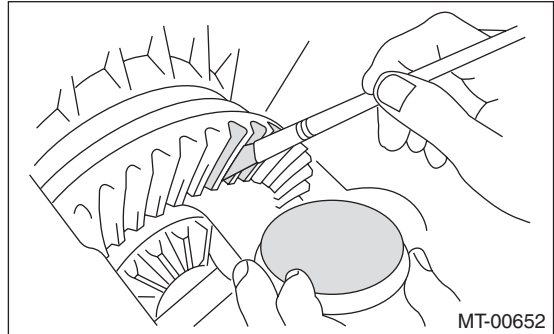

3) Attach the drive pinion shaft assembly to the clutch housing, and tighten with at least 4 bolts.

NOTE:

Install with the remaining liquid gasket, so that the clutch housing and the adapter plate will not be damaged.

Tightening torque:

50 N·m (5.1 kgf·m, 36.9 ft·lb)

4) Turn a few times using the ST.

ST 18631AA000 HANDLE

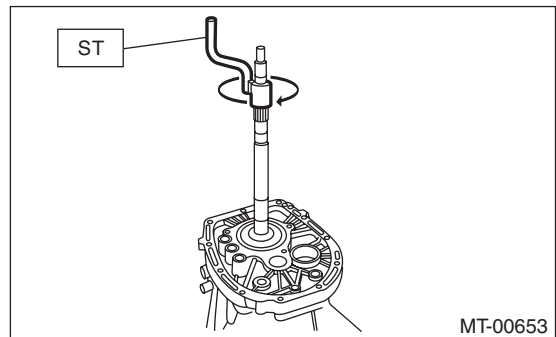

Drive Pinion Shaft Assembly

Brought to you by Eris Studios
NOT FOR RESALE

MANUAL TRANSMISSION AND DIFFERENTIAL

5) Remove the drive pinion shaft assembly, and inspect the mating condition of the teeth. If the mating condition of the teeth is not correct, change shim thickness to adjust backlash.

- Correct tooth contact

Check item: Tooth contact surface is slightly shifted toward the toe side under a no-load condition. (When driving, it moves towards the heel side.)

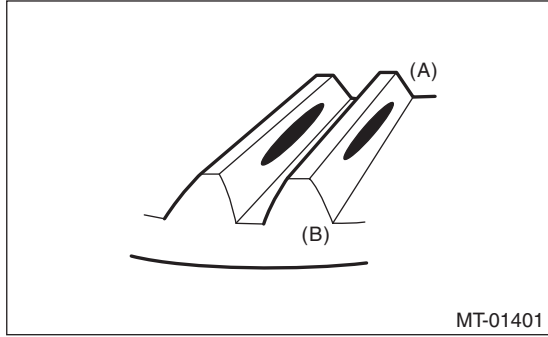

- (A) Toe side
- (B) Heel side

- Face contact

Check item: Backlash is too large.

Contact pattern

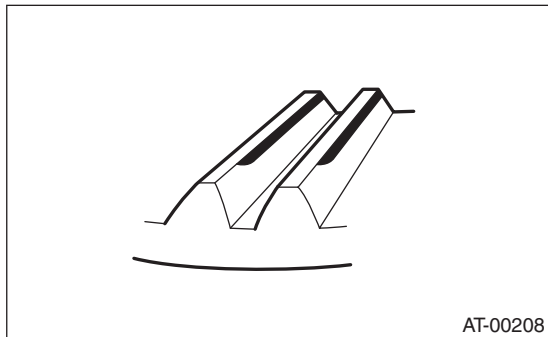

Corrective action: Reconfirm and adjust backlash.

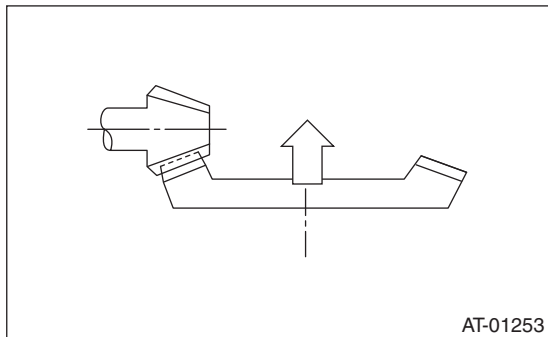

- Flank contact

Check item: Backlash is too small.

Contact pattern

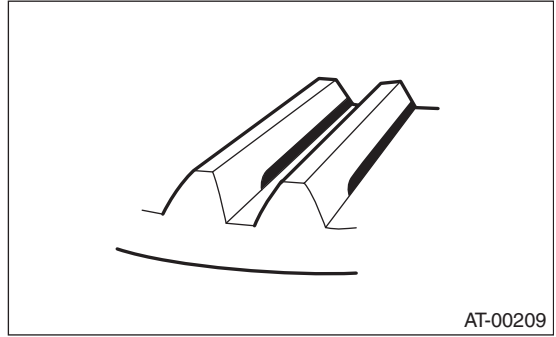

Corrective action: Reconfirm and adjust backlash.

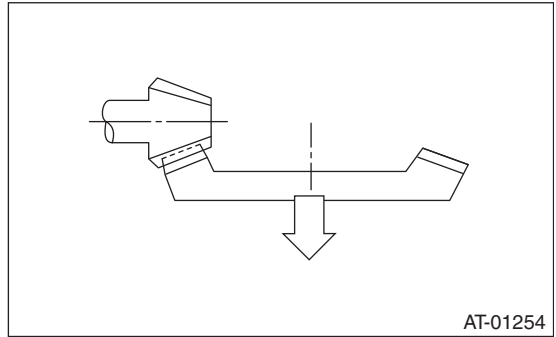

- Toe contact (inside contact)

Check item: Teeth contact area is too small.

Contact pattern

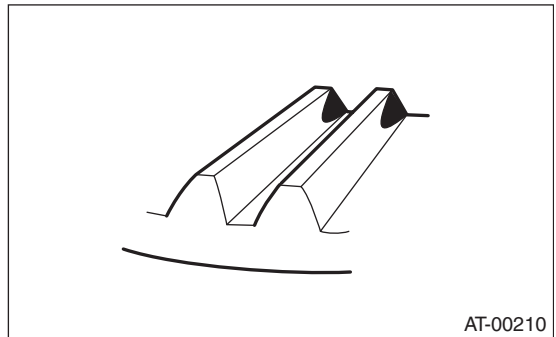

Corrective action: Reduce the thickness of the drive pinion shim according to the procedure for moving the drive pinion away from the driven gear.

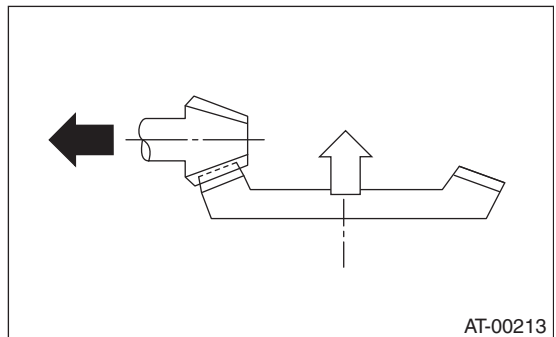

Drive Pinion Shaft Assembly

MANUAL TRANSMISSION AND DIFFERENTIAL

Brought to you by
Chris Studios
NOT FOR SALE

- Heel contact (outside end contact)

Check item: Teeth contact area is too small.

Contact pattern

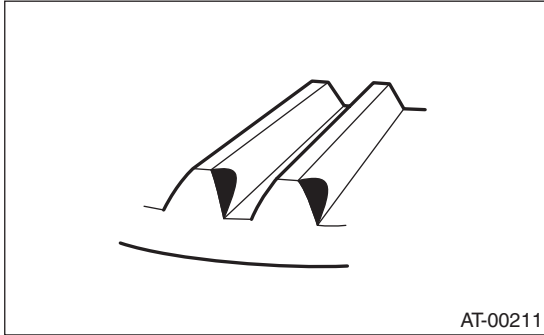

Corrective action: Increase thickness of the drive pinion shim according to the procedures for moving the drive pinion closer to the driven gear.

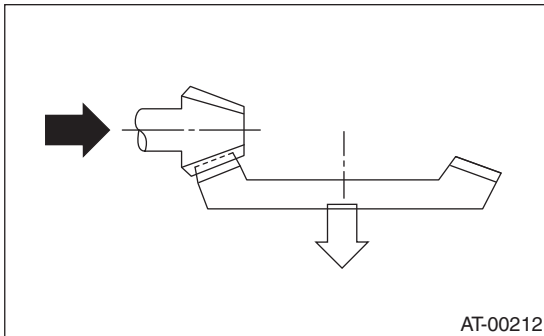

Front Differential Assembly

MANUAL TRANSMISSION AND DIFFERENTIAL

Brought to you by Eris Studios
NOT FOR RESALE

21. Front Differential Assembly

A: REMOVAL

- 1) Remove the manual transmission assembly. <Ref. to 6MT-32, REMOVAL, Manual Transmission Assembly.>
- 2) Prepare the transmission for overhaul. <Ref. to 6MT-38, Preparation for Overhaul.>
- 3) Remove the neutral position switch, back-up light switch and harness. <Ref. to 6MT-42, REMOVAL, Neutral Position Switch.> <Ref. to 6MT-40, REMOVAL, Back-up Light Switch.>
- 4) Remove the extension case. <Ref. to 6MT-44, REMOVAL, Extension Case.>
- 5) Remove the transfer driven gear. <Ref. to 6MT-56, REMOVAL, Transfer Driven Gear.>
- 6) Remove the center differential. <Ref. to 6MT-58, REMOVAL, Center Differential.>
- 7) Remove the transmission case. <Ref. to 6MT-59, REMOVAL, Transmission Case.>
- 8) Remove the individual gear assemblies. <Ref. to 6MT-66, REMOVAL, Main Shaft Assembly.>
- 9) Remove the drive pinion shaft assembly. <Ref. to 6MT-95, REMOVAL, Drive Pinion Shaft Assembly.>
- 10) Remove the lock plates on both sides.

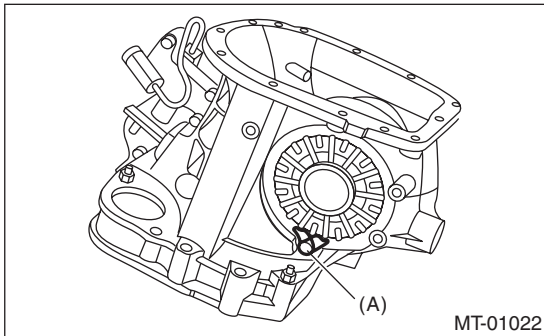

(A) Lock plate

- 11) Remove the differential side retainers on both sides using the ST.

ST1 18630AA010 WRENCH COMPL
RETAINER (RH side)

ST2 18630AA000 WRENCH ASSY (LH side)

NOTE:

Be careful not to damage the section where the clutch case retainer will be attached.

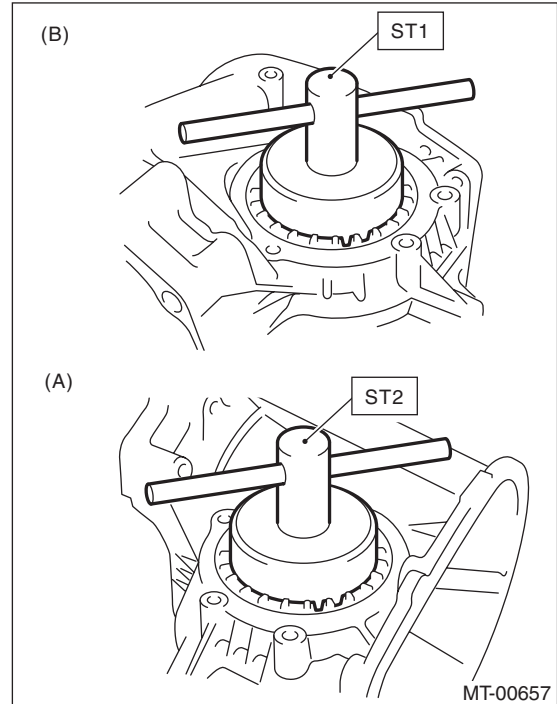

(A) LH side
(B) RH side

- 12) Remove the front differential.

Front Differential Assembly

MANUAL TRANSMISSION AND DIFFERENTIAL

Brought to you by
NOVA Studios
NOT FOR SALE

B: INSTALLATION

- 1) Install the differential assembly to the clutch housing.
- 2) Apply oil to the screw threads of the side retainer.
- 3) Remove the O-rings on both sides of the side retainer.
- 4) Install the differential side retainers to both sides, using the ST.

ST1 18630AA010 WRENCH COMPL
RETAINER (RH side)

ST2 18630AA000 WRENCH ASSY (LH side)

NOTE:

Be careful not to damage the oil seal.

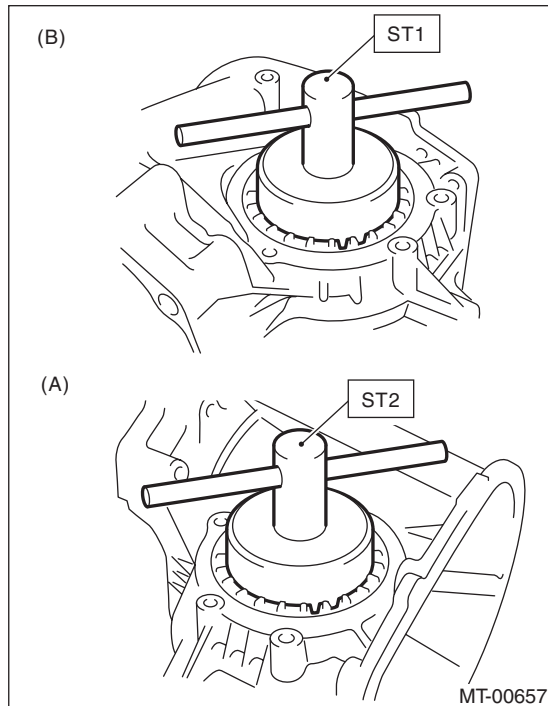

- (A) LH side
(B) RH side

- 5) Inspect and adjust the hypoid gear backlash. <Ref. to 6MT-107, HYPOID GEAR BACKLASH, INSPECTION, Front Differential Assembly.>
- 6) Inspect and adjust the tooth contact. <Ref. to 6MT-99, ADJUSTMENT, Drive Pinion Shaft Assembly.>

- 7) Mark the mating positions of the left and right side retainers and the clutch housing.

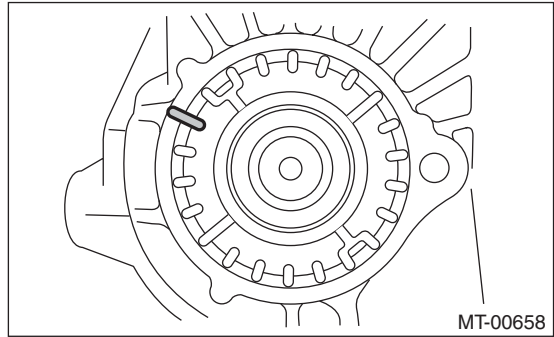

- 8) Remove the differential side retainers from both sides.

NOTE:

When removing the side retainer, record how many times it was turned to remove.

- 9) Install new O-rings to the side retainers on both sides.
- 10) Attach the differential side retainers to both sides.

NOTE:

When attaching, turn the side retainer the same number of turns it took to remove, and align the marks.

- 11) Install the lock plate.

Tightening torque:

25 N·m (2.5 kgf·m, 18.4 ft·lb)

NOTE:

Be careful not to confuse the left and right side lock plates.

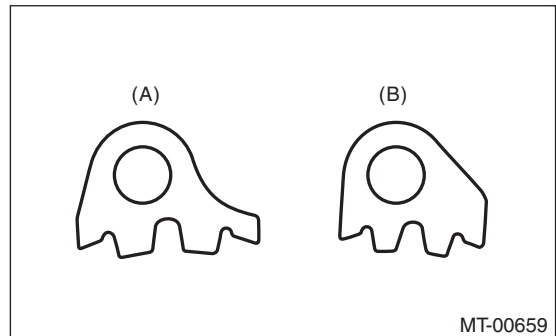

- (A) LH
(B) RH

- 12) Remove any remaining liquid gasket from the clutch housing and adapter plate.

Front Differential Assembly

MANUAL TRANSMISSION AND DIFFERENTIAL

Brought to you by Eris Studios
NOT FOR RESALE

13) Apply liquid gasket to the clutch housing.

Liquid gasket:

THREE BOND 1215 (Part No. 004403007) or equivalent

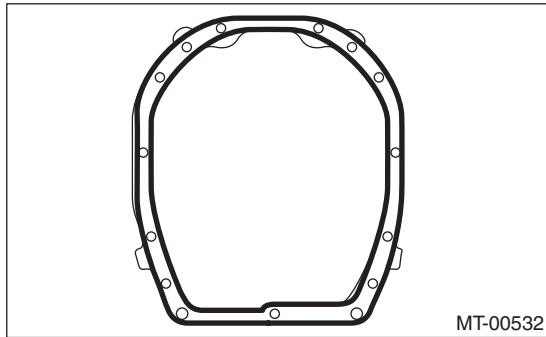

14) Install the drive pinion shaft assembly. <Ref. to 6MT-95, INSTALLATION, Drive Pinion Shaft Assembly.>

15) Install the individual gear assemblies all at once. <Ref. to 6MT-67, INSTALLATION, Main Shaft Assembly.>

16) Install the transmission case. <Ref. to 6MT-61, INSTALLATION, Transmission Case.>

17) Install the center differential. <Ref. to 6MT-58, INSTALLATION, Center Differential.>

18) Install the transfer driven gear. <Ref. to 6MT-56, INSTALLATION, Transfer Driven Gear.>

19) Install the extension case. <Ref. to 6MT-44, INSTALLATION, Extension Case.>

20) Install the neutral position switch, back-up light switch and harness. <Ref. to 6MT-42, INSTALLATION, Neutral Position Switch.> <Ref. to 6MT-40, INSTALLATION, Back-up Light Switch.>

21) Install the manual transmission assembly to the vehicle. <Ref. to 6MT-34, INSTALLATION, Manual Transmission Assembly.>

C: DISASSEMBLY

1. DIFFERENTIAL CASE

1) Fix the differential assembly on a vice, and remove the hypoid driven gear.

ST 18270KA020 SOCKET (E20)

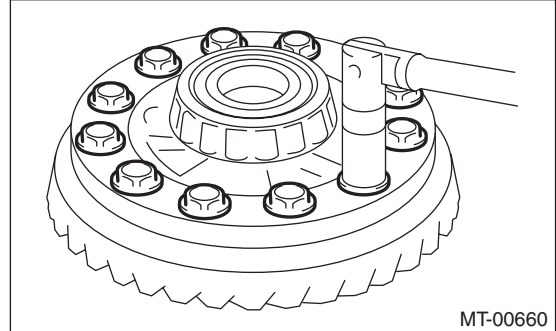

2) Remove the side bearing of the hypoid driven gear using the ST.

ST 399527700 PULLER SET

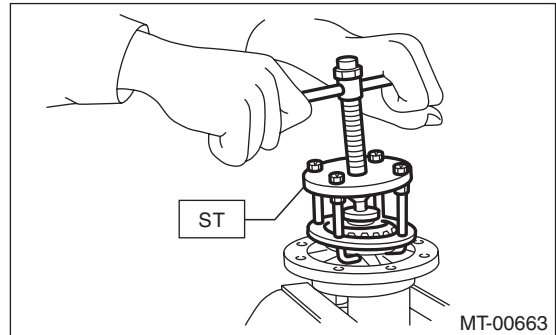

3) Using the ST, remove the roller bearing.

ST 498077000 REMOVER

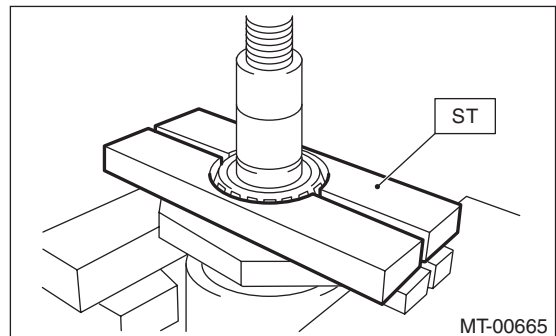

Front Differential Assembly

MANUAL TRANSMISSION AND DIFFERENTIAL

Brought to you by
NOT FOR SALE
Peris Studios

2. SIDE RETAINER

1) Remove the O-ring.

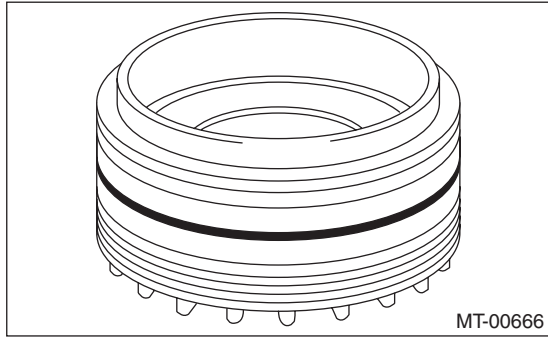

2) Remove the oil seal.

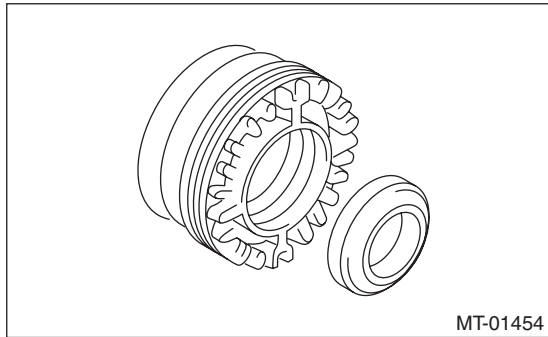

3) Remove the claw of ST1, and attach the claw of ST2.

ST1 398527700 PULLER ASSY
ST2 18760AA000 CLAW

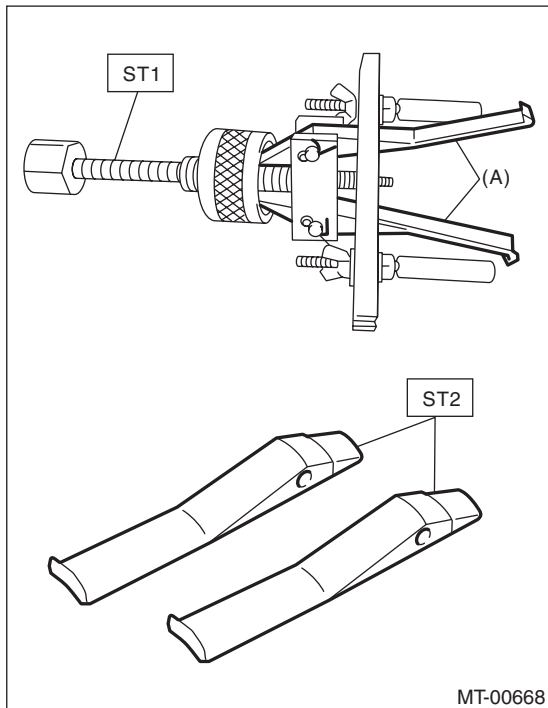

(A) Claw

4) Remove the bearing outer race from the side retainer, using the ST.

ST1 398527700 PULLER ASSY
ST2 18760AA000 CLAW

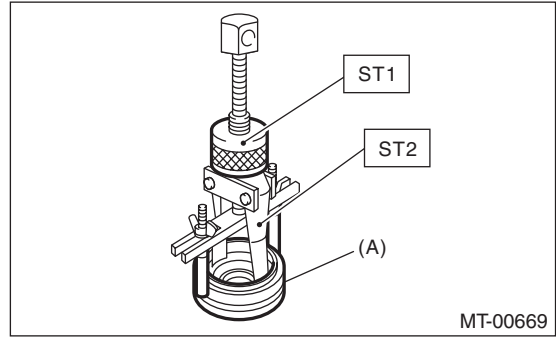

(A) Side retainer

Front Differential Assembly

MANUAL TRANSMISSION AND DIFFERENTIAL

Brought to you by Eris Studios
NOT FOR RESALE

D: ASSEMBLY

1. DIFFERENTIAL CASE

1) Use the ST to attach the RH and LH bearing inner races to the differential case.

ST1 398437700 INSTALLER

ST2 398497701 SEAT

CAUTION:

Do not apply pressure in excess of 20 kN (2.0 ton, 2.2 US ton, 2.0 Imp ton).

NOTE:

Always replace inner races and outer races as a set.

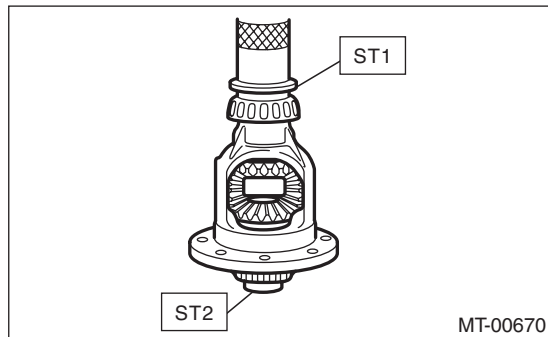

2) Attach the hypoid driven gear to the differential case.

ST 18270KA020 SOCKET (E20)

Tightening torque:

69 N·m (7.0 kgf·m, 50.9 ft·lb)

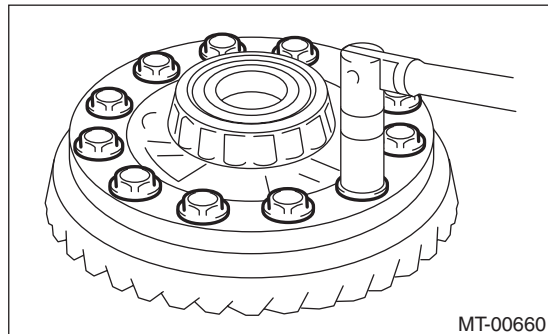

2. SIDE RETAINER

NOTE:

Install the oil seal and O-ring of side retainer after the adjustment of backlash and tooth contact.

1) Install the bearing outer race to side retainer.

2) Using the ST, install the oil seal.

ST 18675AA000 DIFFERENTIAL SIDE OIL SEAL INSTALLER

NOTE:

- Use a new oil seal.
- Apply oil to the oil seal lips.

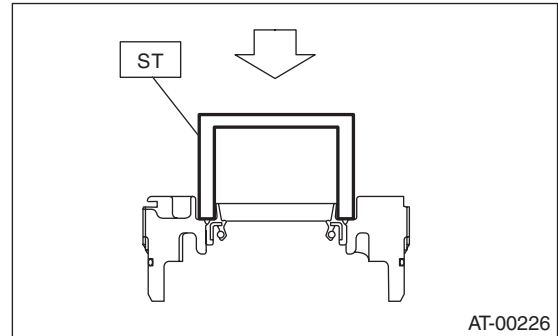

3) Install the O-ring.

NOTE:

Use new O-rings.

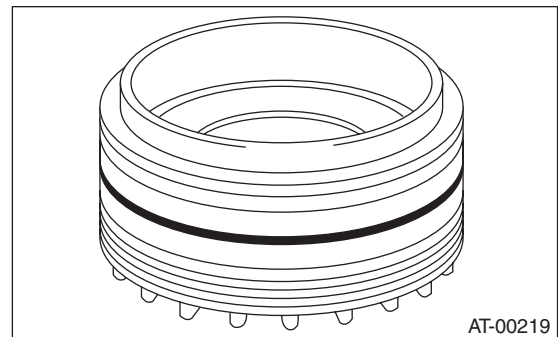

Front Differential Assembly

MANUAL TRANSMISSION AND DIFFERENTIAL

Brought to you by
NOT FOR SALE
Peris Studios

E: INSPECTION

Repair or replace the differential in the following cases:

- If gears are damaged, seized, or are excessively worn.
- If differential case sliding surfaces are damaged, seized, or are excessively worn.
- If there is damage, rust or wear in the bearings or bearing locations.
- If the bearing does not rotate smoothly or an abnormal noise is emitted when turning.

1. HYPOID GEAR BACKLASH

Inspect the hypoid gear backlash. Adjust if out of standard. <Ref. to 6MT-108, HYPOID GEAR BACKLASH, ADJUSTMENT, Front Differential Assembly.>

2. TOOTH CONTACT OF HYPOID GEAR

1) Check that the hypoid gear backlash is within the standard value. Adjust if out of standard. <Ref. to 6MT-108, HYPOID GEAR BACKLASH, ADJUSTMENT, Front Differential Assembly.>

2) Apply a thin uniform coat of lead-free red dye on the surfaces of 3 or 4 hypoid driven gear teeth.

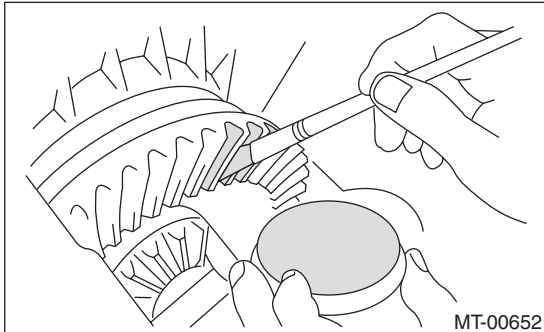

3) Attach the drive pinion shaft assembly, and affix with 4 bolts.

NOTE:

Use old gaskets and washers to prevent the mating surfaces of the housing from becoming damaged.

Tightening torque:

50 N·m (5.1 kgf·m, 36.9 ft·lb)

4) Turn the drive pinion shaft to the left and right for several turns.

5) Remove the drive pinion shaft assembly, and inspect the mating condition of the teeth. If tooth contact is not correct, perform adjustment. <Ref. to 6MT-99, ADJUSTMENT, Drive Pinion Shaft Assembly.>

- Correct tooth contact

NOTE:

In a no load condition, the tooth contact from the center to the toe side is 50-60% (While driving, the tooth contact will shift towards the heel side.)

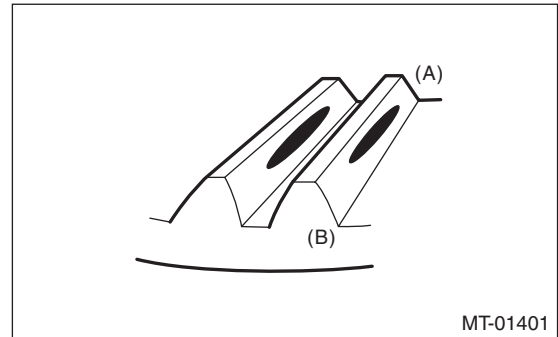

(A) Toe side

(B) Heel side

Front Differential Assembly

MANUAL TRANSMISSION AND DIFFERENTIAL

Brought to you by Eris Studios
NOT FOR RESALE

F: ADJUSTMENT

1. HYPOID GEAR BACKLASH

1) Attach the RH and LH side retainers.

ST1 18630AA010 WRENCH COMPL
RETAINER (RH side)

ST2 18630AA000 WRENCH ASSY (LH side)

NOTE:

- Screw in the RH side side retainer a little further than the LH side.
 - WRENCH ASSY (499787000) can also be used.
- 2) Attach the drive pinion shaft assembly, and affix with 5 bolts.

NOTE:

Use old gaskets and washers to prevent the mating surfaces of the housing from becoming damaged.

Tightening torque:

50 N·m (5.1 kgf·m, 36.9 ft·lb)

3) Using the ST, loosen the differential side retainer RH, and screw in the differential side retainer LH until the hypoid driven gear just contacts the drive pinion.

ST1 18630AA010 WRENCH COMPL
RETAINER (RH side)

ST2 18630AA000 WRENCH ASSY (LH side)

4) Use the ST to turn the drive pinion shaft a few times.

ST 18631AA000 HANDLE

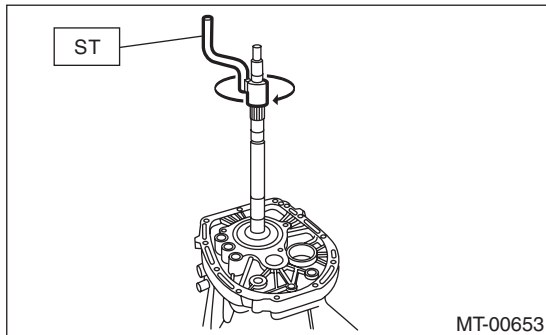

5) Repeat steps 3) and 4) until differential side retainer LH does not turn anymore. For differential side retainer RH, screw in until the inner race and outer race just comes into contact. This is the “zero” backlash state.

6) Mark the mating positions of the left and right side retainers and the clutch housing.

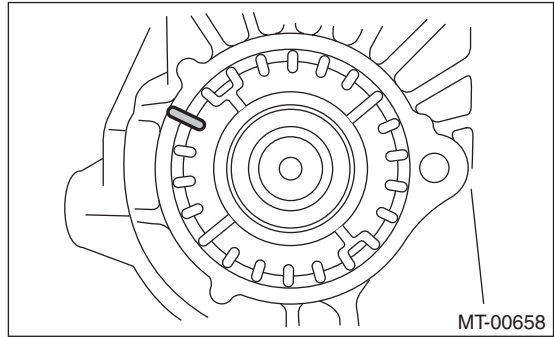

7) Turn the back differential side retainer LH by 3 notches, and screw in the differential side retainer RH by 3 notches.

8) Temporarily attach the LH side retainer lock plate.

9) Turn the differential side retainer RH by 1.25 notches.

10) Temporarily attach the RH side retainer lock plate.

NOTE:

- If the lock plate cannot be aligned, adjust the position toward the tightened side.
 - The notch on the lock plate moves by 0.5 notch if the lock plate is turned upside down when installed.
- 11) Use the ST to fix the drive pinion shaft in place.

ST 18621AA000 ADAPTER WRENCH

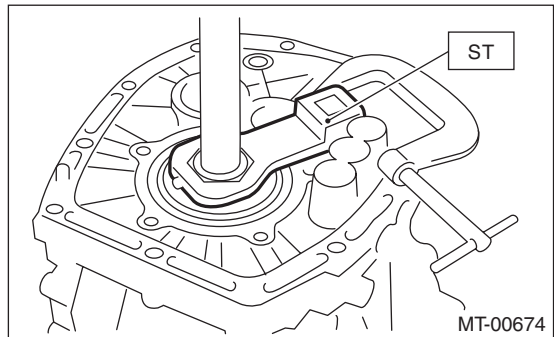

12) Install the SUBARU genuine axle shaft to the front differential left and right sides.

Part No. 38415AA000 AXLE SHAFT

Brought to you by
Chris Studios
NOT FOR SALE

13) Move the axle shaft, and measure the hypoid gear backlash.

- ST1 498255400 PLATE
- ST2 498247001 MAGNET BASE
- ST3 498247100 DIAL GAUGE

Hypoid gear backlash:

0.13 — 0.18 mm (0.0051 — 0.0071 in)

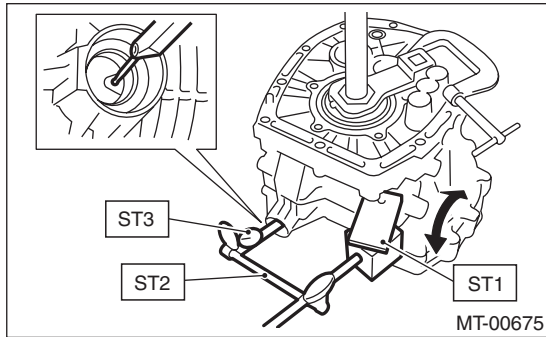

14) If the backlash is out of specified range, remove the left and right retainer lock plates and loosen RH side differential side retainer. Then, adjust the LH side differential side retainer by turning it, and attach the LH side retainer lock plate.

15) Screw in the RH side differential side retainer until the inner race and outer race just come into contact.

2. TOOTH CONTACT OF HYPOID GEAR

Regarding teeth contact conditions, refer to the drive pinion section. <Ref. to 6MT-107, TOOTH CONTACT OF HYPOID GEAR, INSPECTION, Front Differential Assembly.>

Shifter Fork and Rod

MANUAL TRANSMISSION AND DIFFERENTIAL

Brought to you by Eris Studios
NOT FOR RESALE

22. Shifter Fork and Rod

A: REMOVAL

- 1) Remove the manual transmission assembly from the vehicle. <Ref. to 6MT-32, REMOVAL, Manual Transmission Assembly.>
- 2) Prepare the transmission for overhaul. <Ref. to 6MT-38, Preparation for Overhaul.>
- 3) Remove the neutral position switch, back-up light switch and harness. <Ref. to 6MT-42, REMOVAL, Neutral Position Switch.> <Ref. to 6MT-40, REMOVAL, Back-up Light Switch.>
- 4) Remove the extension case. <Ref. to 6MT-44, REMOVAL, Extension Case.>
- 5) Remove the transfer driven gear. <Ref. to 6MT-56, REMOVAL, Transfer Driven Gear.>
- 6) Remove the center differential. <Ref. to 6MT-58, REMOVAL, Center Differential.>
- 7) Remove the transmission case. <Ref. to 6MT-59, REMOVAL, Transmission Case.>
- 8) Remove the individual gear assemblies. <Ref. to 6MT-66, REMOVAL, Main Shaft Assembly.>

B: INSTALLATION

- 1) Install the individual gear assemblies all at once. <Ref. to 6MT-67, INSTALLATION, Main Shaft Assembly.>
- 2) Install the transmission case. <Ref. to 6MT-61, INSTALLATION, Transmission Case.>
- 3) Install the center differential. <Ref. to 6MT-58, INSTALLATION, Center Differential.>
- 4) Install the transfer driven gear. <Ref. to 6MT-56, INSTALLATION, Transfer Driven Gear.>
- 5) Install the extension case. <Ref. to 6MT-44, INSTALLATION, Extension Case.>
- 6) Install the neutral position switch, back-up light switch and harness. <Ref. to 6MT-42, INSTALLATION, Neutral Position Switch.> <Ref. to 6MT-40, INSTALLATION, Back-up Light Switch.>
- 7) Install the manual transmission assembly to the vehicle. <Ref. to 6MT-34, INSTALLATION, Manual Transmission Assembly.>

C: DISASSEMBLY

NOTE:

Discard the removed spring pin, and replace with a new part.

1. REVERSE SHIFTER FORK

- 1) Remove the reverse fork using the ST.
ST 398791700 REMOVER

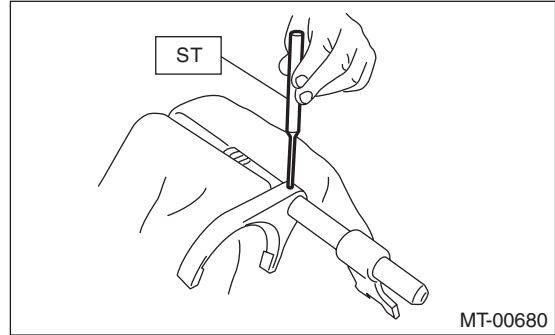

- 2) Remove the reverse shifter arm using the ST.
ST 398791700 REMOVER

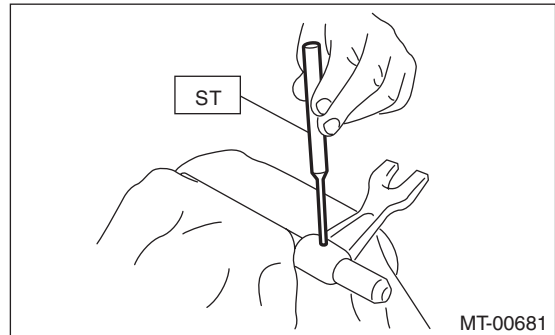

Shifter Fork and Rod

MANUAL TRANSMISSION AND DIFFERENTIAL

Brought to you by
NOVA
SALE
Meris Studios

2. 1ST-2ND, 3RD-4TH SHIFTER FORK

1) Using the ST, remove the 3rd-4th shifter fork.
ST 398791700 REMOVER

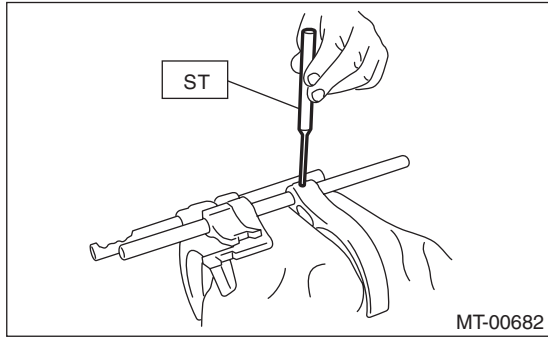

2) Using the ST, remove the 3rd-4th shifter arm.
ST 398791700 REMOVER

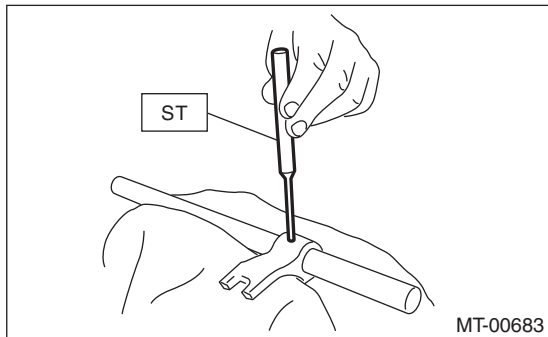

3) Using the ST, remove the 1st-2nd shifter arm and 1st-2nd shifter fork.
ST 398791700 REMOVER

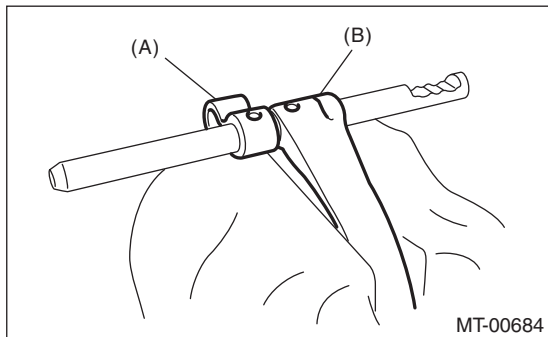

- (A) 1st-2nd shifter arm
- (B) 1st-2nd shifter fork

3. 5TH-6TH SHIFTER FORK

1) Using the ST, remove the 5th-6th shifter fork.
ST 398791700 REMOVER

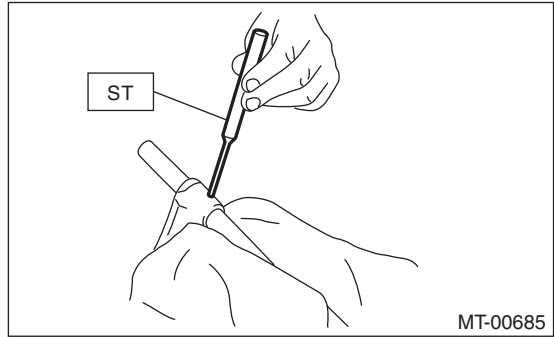

2) Using the ST, remove the 5th-6th shifter arm.
ST 398791700 REMOVER

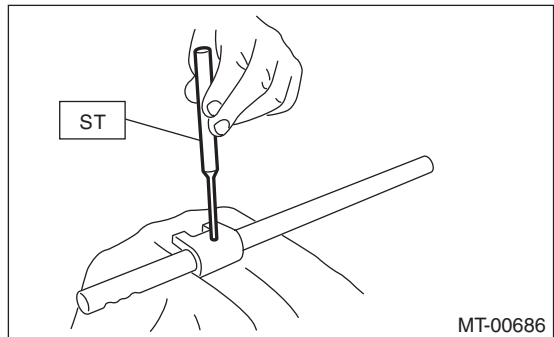

4. SHIFTER ARM SHAFT

Remove the selector arm using the ST.
ST 398791700 REMOVER

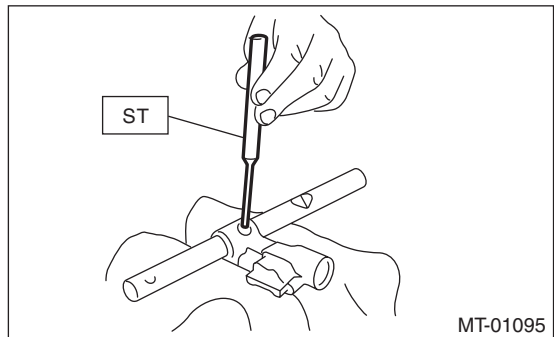

Shifter Fork and Rod

MANUAL TRANSMISSION AND DIFFERENTIAL

Brought to you by Eris Studios
NOT FOR RESALE

5. STRIKING ROD

1) Remove the reverse interlock block and the interlock block from the striking rod.

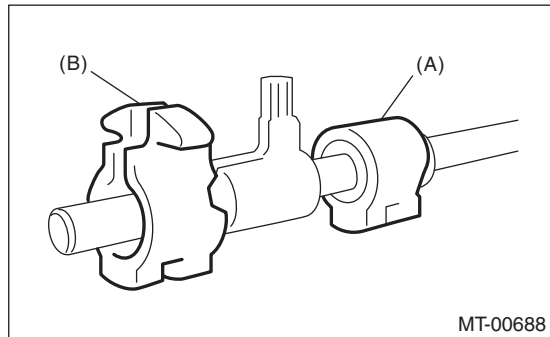

- (A) Reverse interlock block
- (B) Interlock block

2) Remove the reverse interlock arm using the ST.
ST 398791700 REMOVER

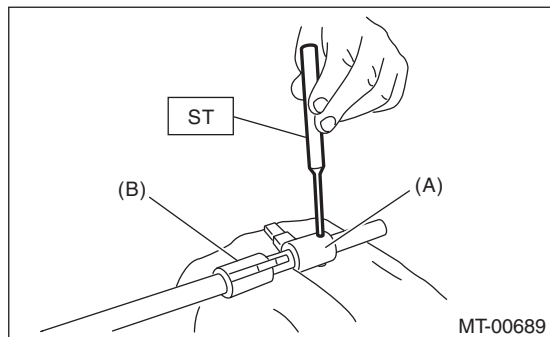

- (A) Reverse interlock arm
- (B) Interlock arm

3) Remove the interlock arm using the ST.
ST 398791700 REMOVER

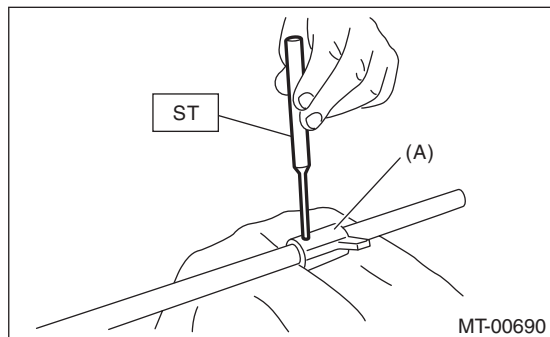

- (A) Interlock arm

D: ASSEMBLY

1. REVERSE SHIFTER FORK

1) Using the ST, install the reverse fork.
ST 398791700 REMOVER

NOTE:

Confirm that the reverse fork and rod are installed in the proper direction.

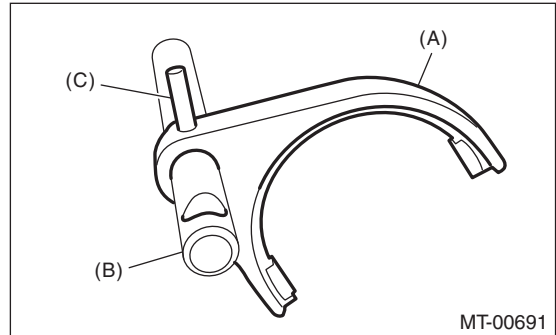

- (A) Reverse fork
- (B) Reverse rod
- (C) Spring pin

2) Using the ST, install the reverse arm.
ST 398791700 REMOVER

NOTE:

Confirm that the reverse arm and rod are installed in the proper direction.

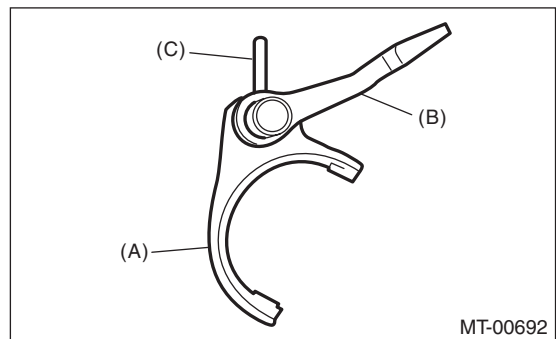

- (A) Reverse arm
- (B) Reverse rod
- (C) Spring pin

Shifter Fork and Rod

MANUAL TRANSMISSION AND DIFFERENTIAL

Brought to you by
NOT FOR SALE
Chris Studios

2. 1ST-2ND, 3RD-4TH SHIFTER FORK

1) Using the ST, install the 1st-2nd shifter fork.
ST 398791700 REMOVER

NOTE:

Make sure that the 1st-2nd shifter fork and rod are installed in the correct direction.

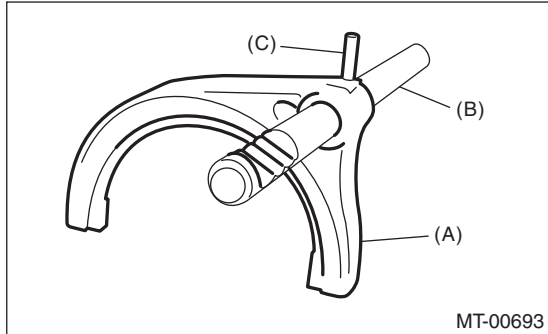

- (A) 1st-2nd shifter fork
- (B) 1st-2nd shifter rod
- (C) Spring pin

2) Using the ST, install the 1st-2nd shifter arm.
ST 398791700 REMOVER

NOTE:

Make sure that the 1st-2nd shifter arm and fork are installed in the correct direction.

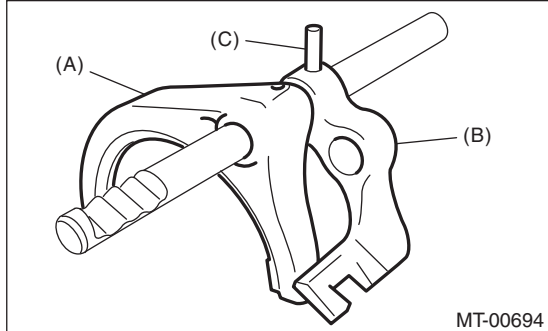

- (A) 1st-2nd shifter fork
- (B) 1st-2nd shifter arm
- (C) Spring pin

3) Using the ST, install the 3rd-4th shifter arm.
ST 398791700 REMOVER

NOTE:

Make sure that the 3rd-4th shifter arm and rod are installed in the correct direction.

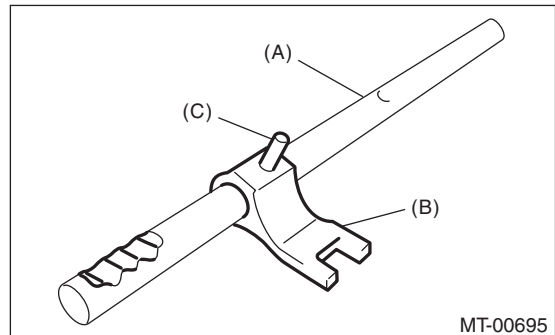

- (A) 3rd-4th shifter rod
- (B) 3rd-4th shifter arm
- (C) Spring pin

4) Attach the 3rd-4th fork rod to the 1st-2nd shifter arm.

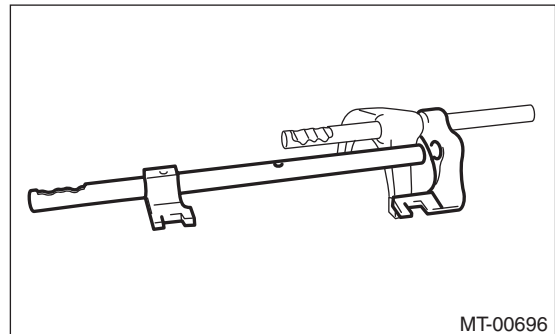

5) Using the ST, install the 3rd-4th shifter fork.
ST 398791700 REMOVER

NOTE:

Make sure that the 3rd-4th shifter fork is installed in the correct direction.

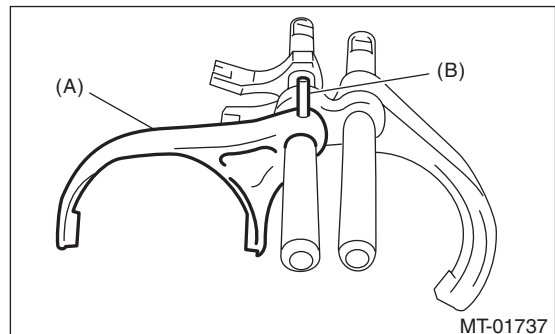

- (A) 3rd-4th shifter fork
- (B) Spring pin

Shifter Fork and Rod

MANUAL TRANSMISSION AND DIFFERENTIAL

Brought to you by Eris Studios
NOT FOR RESALE

3. 5TH-6TH SHIFTER FORK

1) Using the ST, install the 5th-6th shifter arm.
ST 398791700 REMOVER

NOTE:

Make sure that the 5th-6th shifter arm and rod are installed in the correct direction.

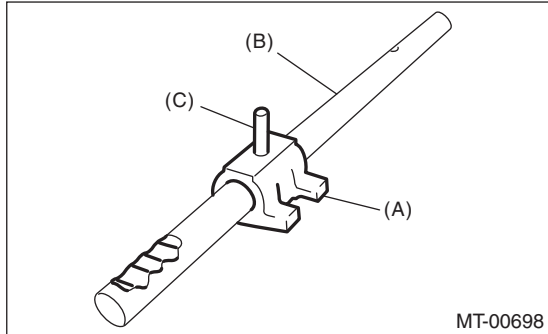

- (A) 5th-6th shifter arm
- (B) 5th-6th shifter rod
- (C) Spring pin

4. SHIFTER ARM SHAFT

Using the ST, install the selector arm.
ST 398791700 REMOVER

NOTE:

Confirm that the selector arm and rod are installed in the proper direction.

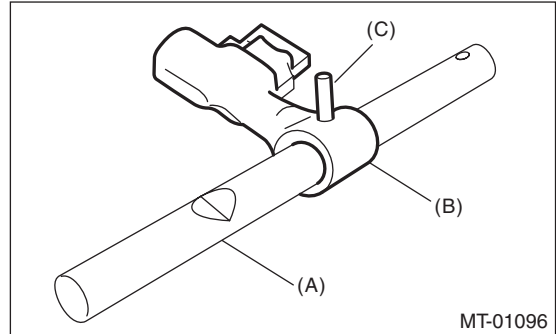

- (A) Selector rod
- (B) Selector arm
- (C) Spring pin

2) Using the ST, install the 5th-6th shifter fork.
ST 398791700 REMOVER

NOTE:

Check that the 5th-6th shifter fork and arm are installed.

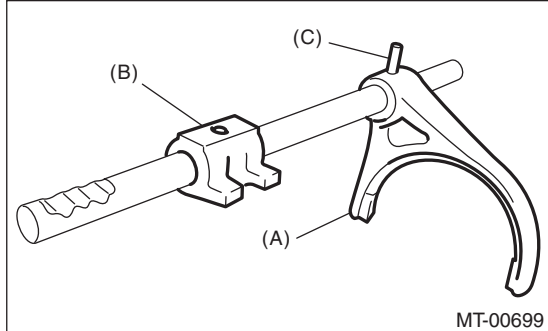

- (A) 5th-6th shifter fork
- (B) 5th-6th shifter arm
- (C) Spring pin

Shifter Fork and Rod

MANUAL TRANSMISSION AND DIFFERENTIAL

Brought to you by
NOT FOR SALE
Peris Studios

5. STRIKING ROD

1) Using the ST, install the reverse interlock arm and interlock arm.

ST 398791700 REMOVER

NOTE:

- Confirm that the reverse interlock arm and rod are installed in the proper direction.
- Confirm that the interlock arm and rod are installed in the proper direction.

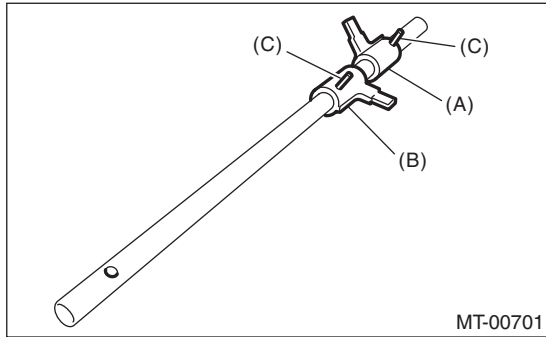

- (A) Reverse interlock arm
- (B) Interlock arm
- (C) Spring pin

2) Attach the reverse interlock block and interlock block to the striking rod.

NOTE:

Confirm that the reverse interlock block and interlock block are installed in the proper direction.

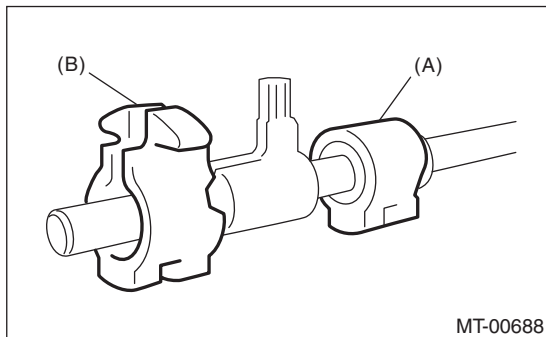

- (A) Reverse interlock block
- (B) Interlock block

E: INSPECTION

- 1) Check the shift shaft and shift rod for damage. Replace if damaged.
- 2) Repair or replace the gearshift mechanism if excessively worn, bent or defective in any way.

F: ADJUSTMENT

1. 1ST-2ND FORK ROD SELECTION

NOTE:

In the following conditions, perform the procedures below.

- Replacement of the 1st and 2nd driven gear
- 1st and 2nd synchro ring assembly replacement
- Adapter plate replacement
- Driven shaft replacement
- 1st-2nd hub and sleeve assembly replacement.

1) Insert the drive pinion assembly into the adapter plate.

NOTE:

Confirm that the thrust bearing outer race has not been removed and the drive pinion is not lifted.

2) Set the height gauge to the adapter plate. Lower the height gauge indicator to the mating surface of the adapter plate and case, and set to zero points.

ST 18853AA000 HEIGHT GAUGE

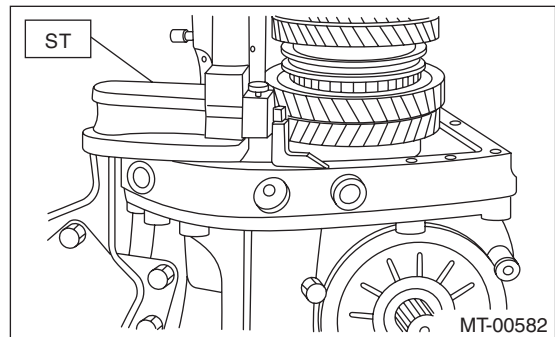

NOTE:

- The adapter plate will be the base point for the measurement. Use a scraper to remove any gasket material remaining on the end face.
- During measurement, do not place the height gauge in the shaded area shown in the figure.

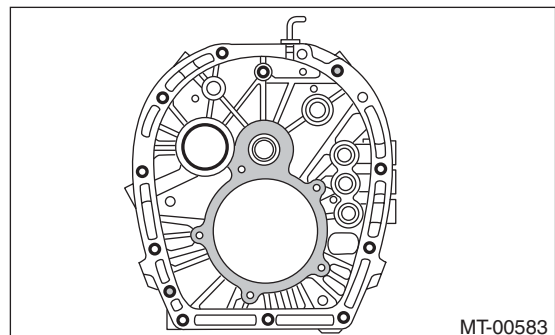

3) Select the main shaft snap ring. <Ref. to 6MT-79, ADJUSTMENT, Main Shaft Assembly.>

Shifter Fork and Rod

MANUAL TRANSMISSION AND DIFFERENTIAL

Brought to you by Eris Studios
NOT FOR RESALE

4) Measure "B1" and "B2" as shown in the figure.

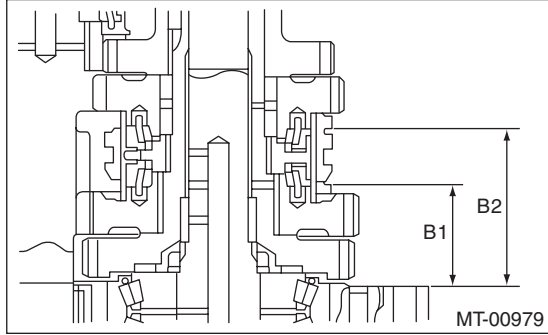

5) Shift the 1st-2nd sleeve to the 1st driven gear side, push down to the stopper, and measure "B1".

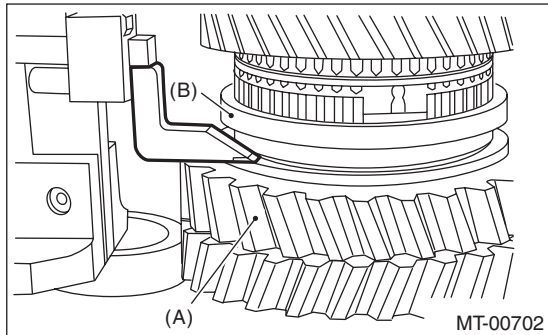

- (A) 1st driven gear
- (B) 1st-2nd sleeve

NOTE:

- Set the height gauge indicator near the measurement target, and lock dial (1) as shown in the figure. Turn dial (2), and set the indicator to the 1st side end surface of the sleeve.
- Turn approximately 72° at a time, and measure the sleeve in 5 locations. Round off the 2 highest and 2 lowest measurement values. The remaining center value is used as the measurement value.

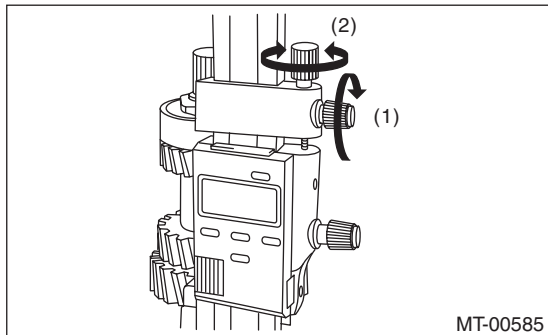

6) Set the height gauge indicator upside down.

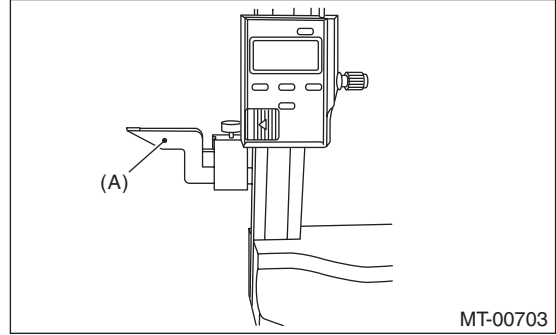

- (A) Indicator

7) Shift the 1st-2nd sleeve to the 2nd driven gear side, push up on the stopper, and measure "B2".

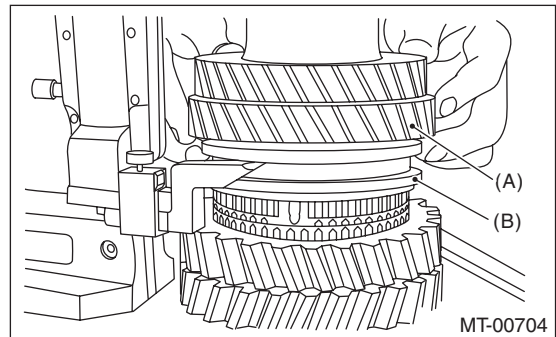

- (A) 2nd driven gear
- (B) 1st-2nd sleeve

NOTE:

- Set the height gauge indicator near the measurement target, and lock dial (1) as shown in the figure. Turn dial (2), and set the indicator to the 2nd side end surface of the sleeve.
- The measurement is to be performed with two persons, while holding the sleeve straight.
- Turn approximately 72° at a time, and measure the sleeve in 5 locations. Round off the 2 highest and 2 lowest measurement values. The remaining center value is used as the measurement value.

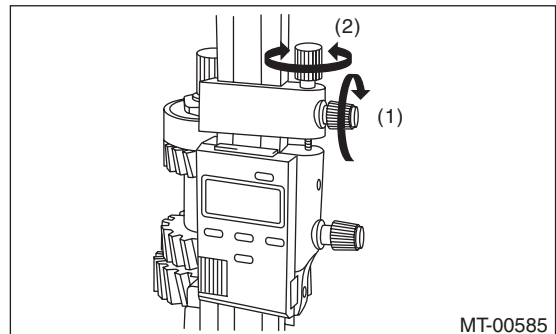

Shifter Fork and Rod

MANUAL TRANSMISSION AND DIFFERENTIAL

Brought to you by
 NOT FOR SALE
 Peris Studios

8) According to both of the measurements, calculate the neutral position of the 1st-2nd sleeve. From the following calculation, select a fork rod which matches the calculated value.

Calculation: $T = (B1 + B2) / 2$

T: 1st-2nd sleeve center position

B1: Height from the adapter plate end to the sleeve end, when shifted to 1st gear

B2: Measured height from the adapter plate end to the sleeve end, when shifted to 2nd gear: +55 mm (2.17 in)

NOTE:

Attach the indicator upside down in comparison to the setting procedures for the zero point. Add “d1” [Value: 55 mm (2.17 in)] from the figure below to “B2”, and measure “B2”.

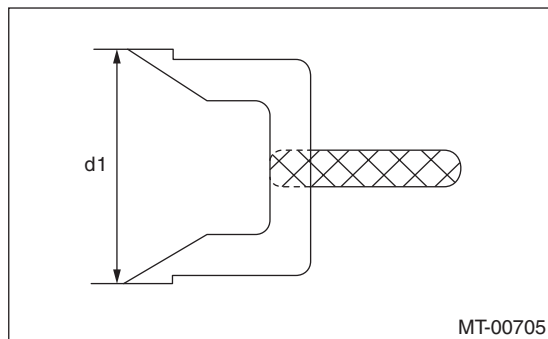

T	mm (in)	Lot No. (marking)
62.63 — 62.93 (2.4657 — 2.4776)		32801AA240 (3)
62.93 — 63.23 (2.4776 — 2.4894)		32801AA180 (1)
63.23 — 63.53 (2.4894 — 2.5012)		32801AA190 (none)

2. 3RD-4TH FORK ROD SELECTION

NOTE:

In the following conditions, perform the procedures below.

- Main shaft replacement
 - 3rd, and 3rd to 6th drive gear and bushing replacement
 - 3rd, and 3rd to 6th synchro assembly replacement
 - 3rd-4th hub and sleeve assembly replacement
- 1) Insert the main shaft assembly into the adapter plate.

- 2) Set the height gauge to the adapter plate. Lower the height gauge indicator to the top surface of the snap ring groove, and set to the zero point on the upper side of the main rear bearing.

ST 18853AA000 HEIGHT GAUGE

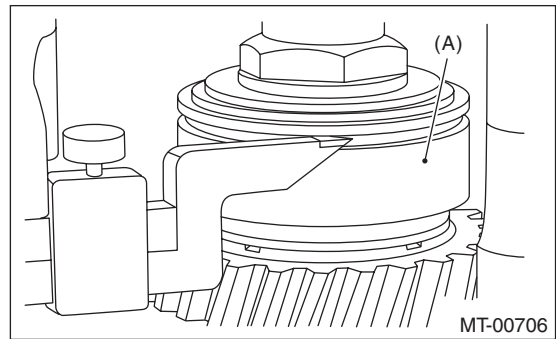

(A) Ball bearing

NOTE:

- The height gauge will be set on the adapter plate during the measurement. Use a scraper to remove any gasket material remaining on the end face.
- During measurement, do not place the height gauge in the shaded area shown in the figure.

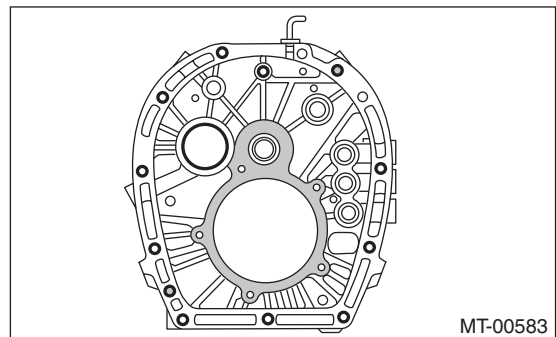

Shifter Fork and Rod

MANUAL TRANSMISSION AND DIFFERENTIAL

Brought to you by Eris Studios
NOT FOR RESALE

3) Use a height gauge to measure “C1” and “C2” as shown in the figure.

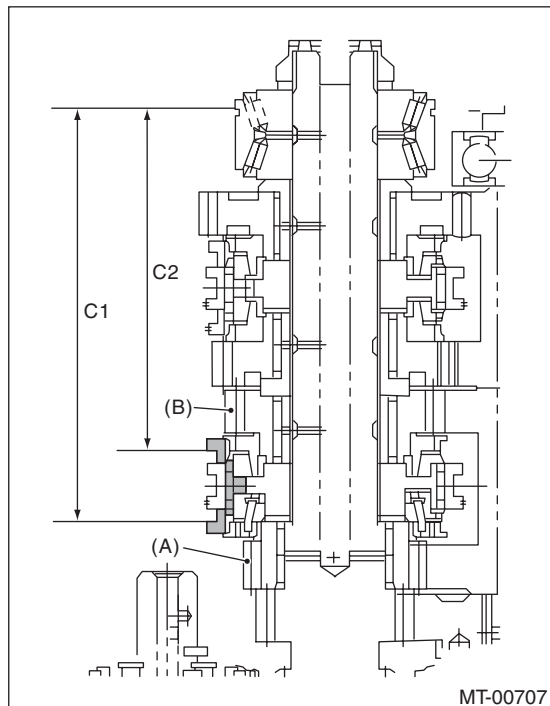

- (A) 3rd drive gear
- (B) 4th drive gear

(1) Shift the 3rd-4th sleeve to the 4th gear side, push up on the stopper, and measure “C2”.

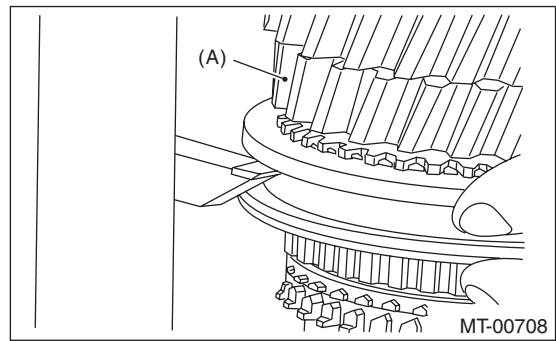

(A) 4th drive gear

NOTE:

- Set the height gauge indicator near the measurement target, and lock dial (1) as shown in the figure.
- Turn dial (2), and set the indicator to the 4th side end surface of the sleeve.
- The measurement is to be performed with two persons, while holding the sleeve straight.
- Turn approximately 72° at a time, and measure the sleeve in 5 locations. Round off the 2 highest and 2 lowest measurement values. The remaining center value is used as the measurement value.

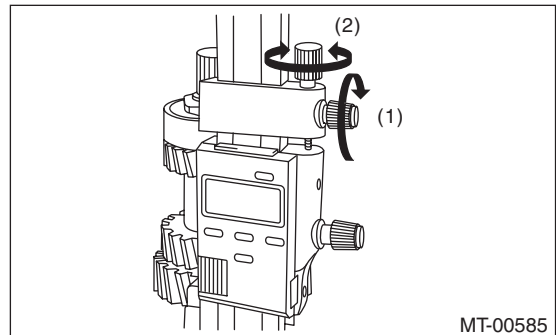

(2) Set the height gauge indicator upside down.

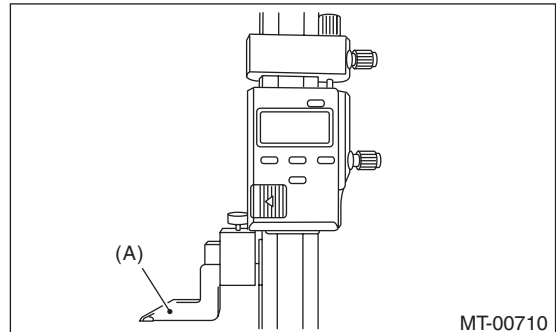

(A) Indicator

Shifter Fork and Rod

Brought to you by *Peris Studios*
 NOT FOR SALE

(3) Shift the 3rd-4th sleeve to the 3rd drive gear side, push down to the stopper, and measure "C1".

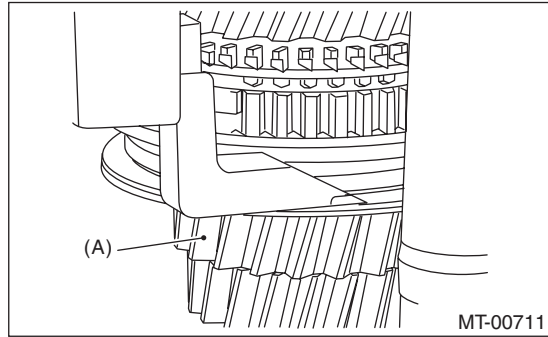

(A) 3rd drive gear

NOTE:

- Set the height gauge indicator near the measurement target, and lock dial (1) as shown in the figure. Turn dial (2), and set the indicator to the 3rd side end surface of the sleeve.
- Turn approximately 72° at a time, and measure the sleeve in 5 locations. Round off the 2 highest and 2 lowest measurement values. The remaining center value is used as the measurement value.

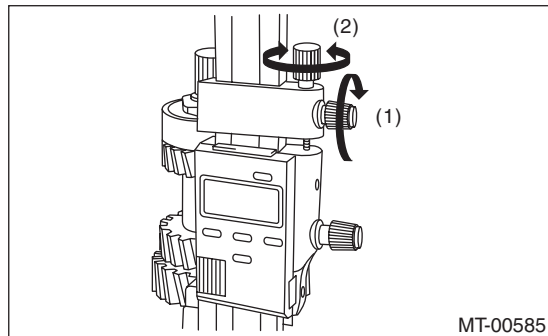

4) According to both of the measurements, calculate the neutral position of the 3rd-4th sleeve. From the following calculation, select a fork rod which matches the calculated value.

Calculation: $T = (C1 + C2) / 2$

T: 3rd-4th sleeve center position

C1: Measured depth from the main shaft rear bearing snap ring groove to the sleeve end, when shifted to 3rd gear: +55 mm (2.17 in)

C2: Measured depth from the main shaft rear bearing snap ring groove to the sleeve end, when shifted to 4th gear

NOTE:

Attach the indicator upside down in comparison to the setting procedures for the zero point. Add "d1" [Value: 55 mm (2.17 in)] from the figure below to "C1", and measure "C1".

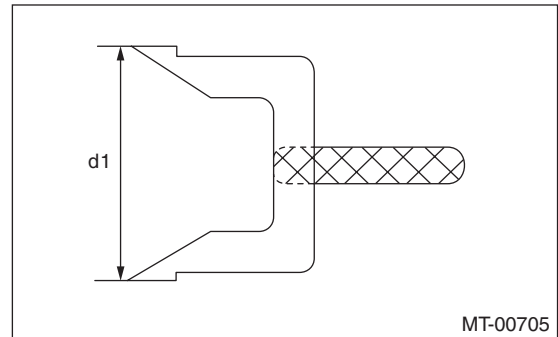

T mm (in)	Lot No. (marking)		
	M.SFT Snap ring 805072010 [t = 1.65 mm (0.065 in)]	M.SFT Snap ring 805072011 [t = 1.95 mm (0.077 in)]	M.SFT Snap ring 805072012 [t = 2.25 mm (0.089 in)]
137.22 — 137.52 (5.4024 — 5.4142)	32809AA171 (none)	32809AA181 (2)	32809AA191 (4)
137.52 — 137.82 (5.4142 — 5.4260)	32809AA161 (1)	32809AA171 (none)	32809AA181 (2)
137.82 — 138.12 (5.4260 — 5.4379)	32809AA141 (3)	32809AA161 (1)	32809AA171 (none)

T = Thickness

Shifter Fork and Rod

MANUAL TRANSMISSION AND DIFFERENTIAL

Brought to you by Eris Studios
NOT FOR RESALE

3. 5TH-6TH FORK ROD SELECTION

NOTE:

In the following conditions, perform the procedures below.

- Main shaft replacement
- 3rd to 6th drive gear and bushing replacement
- 3rd to 6th synchro ring assembly replacement
- 3rd-4th hub and sleeve assembly replacement
- 5th-6th hub and sleeve assembly replacement

1) Insert the main shaft assembly into the adapter plate.

2) Set the height gauge to the adapter plate. Lower the height gauge indicator to the upper face of the snap ring groove or the upper side of the main rear bearing. Set to zero point.

ST 18853AA000 HEIGHT GAUGE

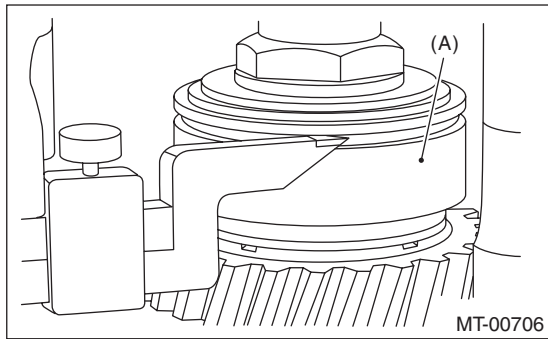

(A) Ball bearing

NOTE:

- The height gauge will be set on the adapter plate during the measurement. Use a scraper to remove any gasket material remaining on the end face.
- During measurement, do not place the height gauge in the shaded area shown in the figure.

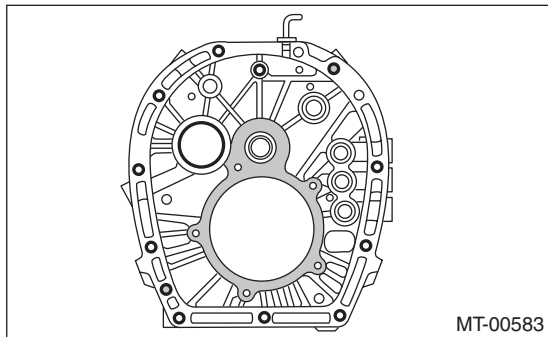

3) Use a height gauge to measure “D1” and “D2” as shown in the figure.

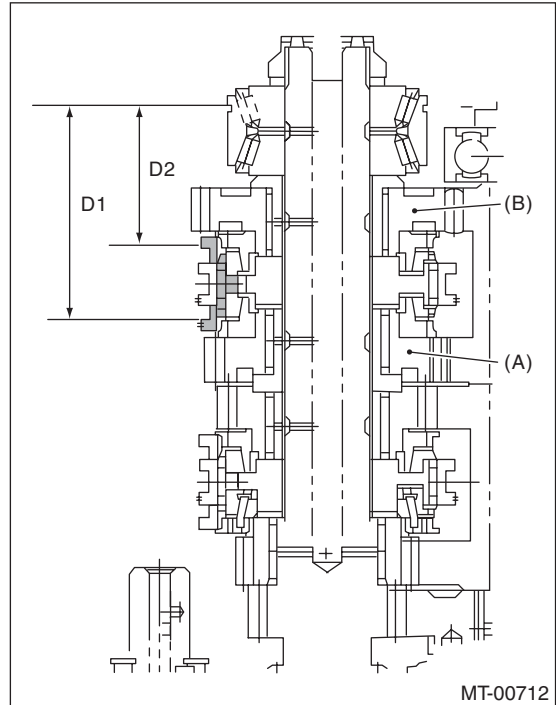

- (A) 5th main gear
- (B) 6th main gear

Shifter Fork and Rod

MANUAL TRANSMISSION AND DIFFERENTIAL

Brought to you by
NOT FOR SALE
Meris Studios

(1) Shift the 5th-6th sleeve to the 6th main gear side, push up on the stopper, and measure "D2".

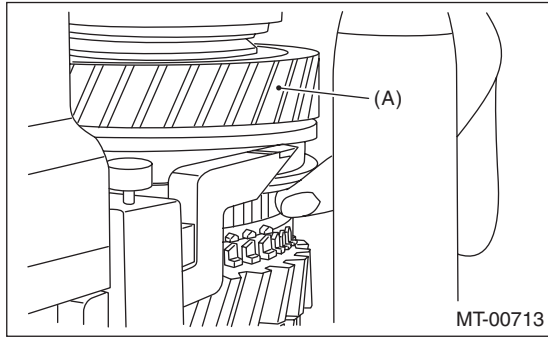

(A) 6th main gear

(3) Shift the 5th-6th sleeve to the 5th main gear side, push down to the stopper, and measure "D1".



(A) 5th main gear

NOTE:

- Set the height gauge indicator near the measurement target, and lock dial (1) as shown in the figure. Turn dial (2), and set the indicator to the 6th side end surface of the sleeve.
- The measurement is to be performed with two persons, while holding the sleeve straight.
- Turn approximately 72° at a time, and measure the sleeve in 5 locations. Round off the 2 highest and 2 lowest measurement values. The remaining center value is used as the measurement value.

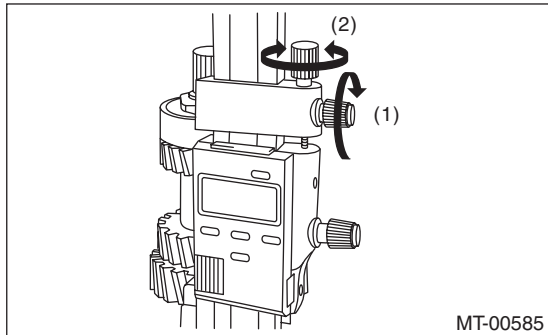

(2) Set the height gauge indicator upside down.

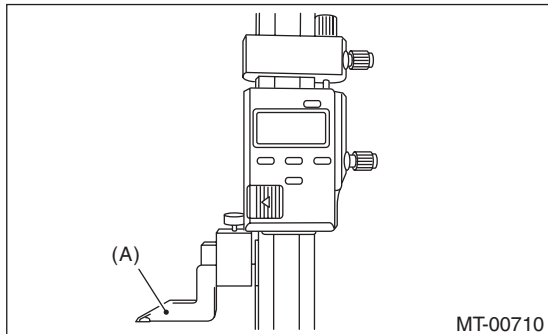

(A) Indicator

NOTE:

- Set the height gauge indicator near the measurement target, and lock dial (1) as shown in the figure. Turn dial (2), and set the indicator to the 5th side end surface of the sleeve.
- Turn approximately 72° at a time, and measure the sleeve in 5 locations. Round off the 2 highest and 2 lowest measurement values. The remaining center value is used as the measurement value.

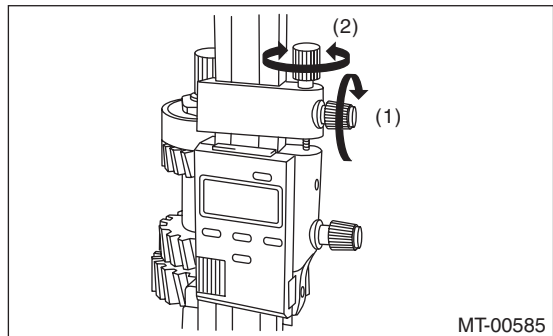

Shifter Fork and Rod

MANUAL TRANSMISSION AND DIFFERENTIAL

Brought to you by Eris Studios
NOT FOR RESALE

4) According to both of the measurements, calculate the neutral position of the 5th-6th sleeve. From the following calculation, select a fork rod which matches the calculated value.

Calculation: $T = (D1 + D2) / 2$

T: 5th-6th sleeve center position

D1: Measured length from the shaft rear bearing snap ring groove to the sleeve groove end, when shifted to 5th gear [Value: +55 mm (2.17 in)]

D2: Measured length from the main shaft rear bearing snap ring groove to the sleeve groove end, when shifted to 6th gear

NOTE:

Attach the indicator upside down in comparison to the setting procedures for the zero point. Add "d1" [Value: 55 mm (2.17 in)] from the figure below to "D1", and measure "D1".

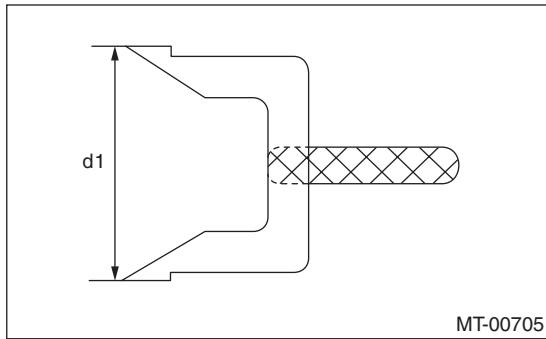

MT-00705

T mm (in)	Lot No. (marking)		
	M.SFT Snap ring 805072010 [t = 1.65 mm (0.065 in)]	M.SFT Snap ring 805072011 [t = 1.95 mm (0.077 in)]	M.SFT Snap ring 805072012 [t = 2.25 mm (0.089 in)]
64.12 — 64.42 (2.5244 — 2.5362)	32945AA021 (none)	32945AA031 (2)	32945AA041 (4)
64.42 — 64.72 (2.5362 — 2.5480)	32945AA011 (1)	32945AA021 (none)	32945AA031 (2)
64.72 — 65.02 (2.5480 — 2.5598)	32945AA001 (3)	32945AA011 (1)	32945AA021 (none)

T = Thickness

4. REVERSE FORK ROD SELECTION

NOTE:

In the following conditions, perform the procedures below.

- Reverse idler gear replacement.
- Reverse idler gear No. 2 replacement.
- Adapter plate replacement.
- Base replacement.

- 1) Insert the reverse idler gear assembly into the adapter plate.
- 2) Tighten the base COMPL attachment bolts.

Tightening torque:

25 N·m (2.5 kgf·m, 18.4 ft·lb)

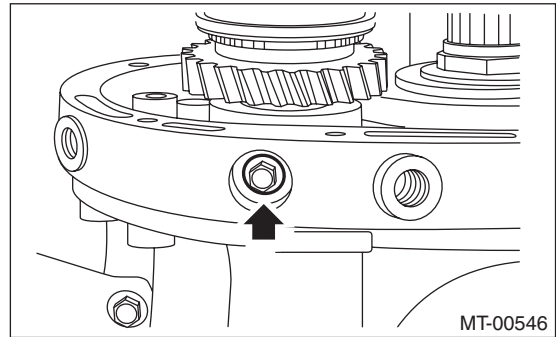

MT-00546

- 3) Set the height gauge to the adapter plate. Lower the height gauge indicator to the mating surface of the adapter plate and case, and set to zero points.
ST 18853AA000 HEIGHT GAUGE

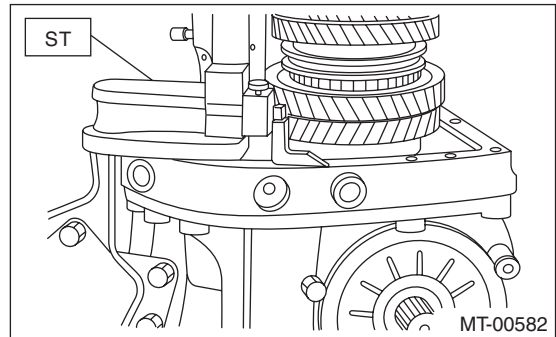

MT-00582

NOTE:

- The adapter plate will be the base point for the measurement. Use a scraper to remove any gasket material remaining on the end face.
- During measurement, do not place the height gauge in the shaded area shown in the figure.

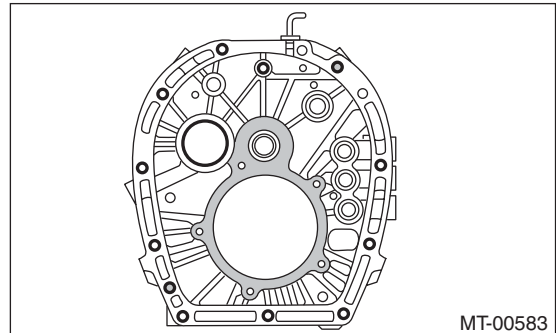

MT-00583

Shifter Fork and Rod

MANUAL TRANSMISSION AND DIFFERENTIAL

Brought to you by
 NOVA
 RESALE
 Auto Parts Studios

4) Press fit the reverse sleeve to the reverse idler gear No. 2, and measure "T".

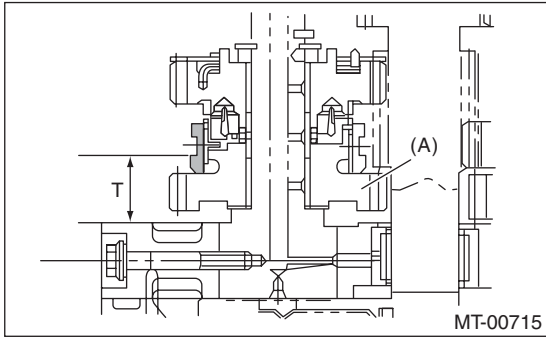

(A) Reverse idler gear No. 2

5) Calculate the neutral position of the reverse sleeve according to the measurement. From the following calculation, select a fork rod which matches the calculated value.

Calculation: $T + 4.8 \text{ mm (0.189 in)}$

$T + 4.8 \text{ mm (0.189 in)}$ mm (in)	Lot No. (marking)
33.50 — 33.80 (1.3189 — 1.3307)	32816AA110 (1)
33.80 — 34.10 (1.3307 — 1.3425)	32816AA130 (none)
34.10 — 34.40 (1.3425 — 1.3543)	32816AA140 (2)
T = Thickness	

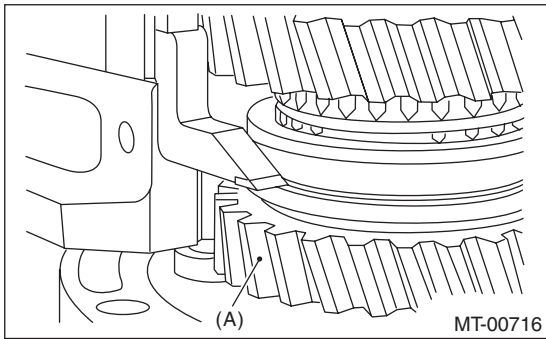

(A) Reverse idler gear No. 2

NOTE:

- Set the height gauge indicator near the measurement target, and lock dial (1) as shown in the figure. Turn dial (2), and set the indicator to the end face of the reverse sleeve side.
- Turn approximately 72° at a time, and measure the sleeve in 5 locations. Round off the 2 highest and 2 lowest measurement values. The remaining center value is used as the measurement value.

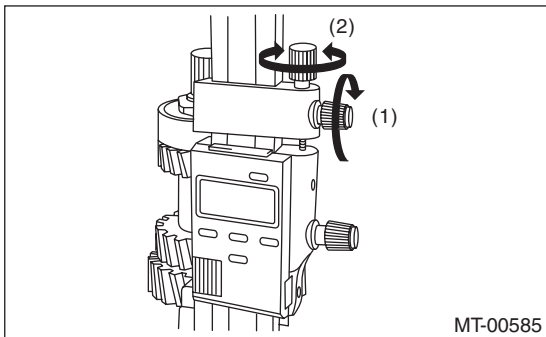

23. Clutch Housing

A: REMOVAL

- 1) Remove the manual transmission assembly from the vehicle. <Ref. to 6MT-32, REMOVAL, Manual Transmission Assembly.>
- 2) Prepare the transmission for overhaul. <Ref. to 6MT-38, Preparation for Overhaul.>
- 3) Remove the neutral position switch, back-up light switch and harness. <Ref. to 6MT-42, REMOVAL, Neutral Position Switch.> <Ref. to 6MT-40, REMOVAL, Back-up Light Switch.>
- 4) Remove the extension case. <Ref. to 6MT-44, REMOVAL, Extension Case.>
- 5) Remove the transfer driven gear. <Ref. to 6MT-56, REMOVAL, Transfer Driven Gear.>
- 6) Remove the center differential. <Ref. to 6MT-58, REMOVAL, Center Differential.>
- 7) Remove the transmission case. <Ref. to 6MT-59, REMOVAL, Transmission Case.>
- 8) Remove the individual gear assemblies. <Ref. to 6MT-66, REMOVAL, Main Shaft Assembly.>
- 9) Remove the drive pinion shaft assembly. <Ref. to 6MT-95, REMOVAL, Drive Pinion Shaft Assembly.>
- 10) Remove the front differential assembly. <Ref. to 6MT-102, REMOVAL, Front Differential Assembly.>

B: INSTALLATION

- 1) Install the pitching stopper bracket.

Tightening torque:

41 N·m (4.2 kgf·m, 30.2 ft·lb)

- 2) Install the front differential assembly. <Ref. to 6MT-103, INSTALLATION, Front Differential Assembly.>
- 3) Install the drive pinion shaft assembly. <Ref. to 6MT-95, INSTALLATION, Drive Pinion Shaft Assembly.>
- 4) Install the individual gear assemblies all at once. <Ref. to 6MT-67, INSTALLATION, Main Shaft Assembly.>
- 5) Install the transmission case. <Ref. to 6MT-61, INSTALLATION, Transmission Case.>
- 6) Install the center differential. <Ref. to 6MT-58, INSTALLATION, Center Differential.>
- 7) Install the transfer driven gear. <Ref. to 6MT-56, INSTALLATION, Transfer Driven Gear.>
- 8) Install the extension case. <Ref. to 6MT-44, INSTALLATION, Extension Case.>
- 9) Install the neutral position switch, back-up light switch and harness. <Ref. to 6MT-42, INSTALLATION, Neutral Position Switch.> <Ref. to 6MT-40, INSTALLATION, Back-up Light Switch.>

- 10) Install the manual transmission assembly to the vehicle. <Ref. to 6MT-34, INSTALLATION, Manual Transmission Assembly.>

C: DISASSEMBLY

- 1) Remove the clutch release bearing guide.

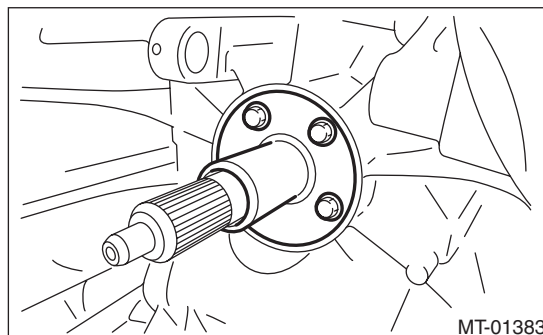

- 2) Remove the oil seal.

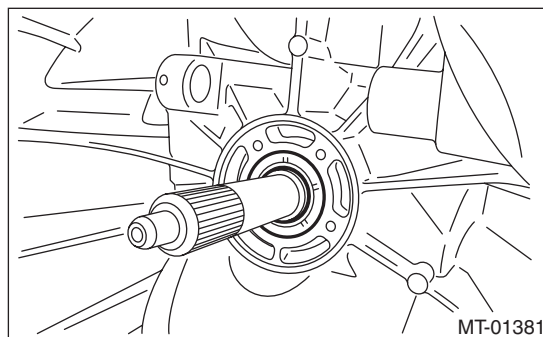

D: ASSEMBLY

1) Attach the oil seal to the clutch housing, being careful not to damage the seal.

NOTE:

Use a new oil seal.

ST 18657AA020 OIL SEAL INSTALLER

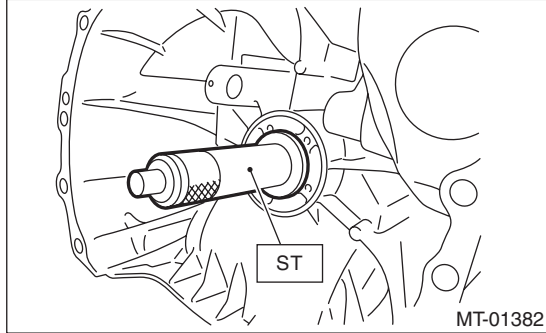

2) Install the clutch release bearing guide.

Tightening torque:

6.4 N·m (0.7 kgf-m, 4.7 ft-lb)

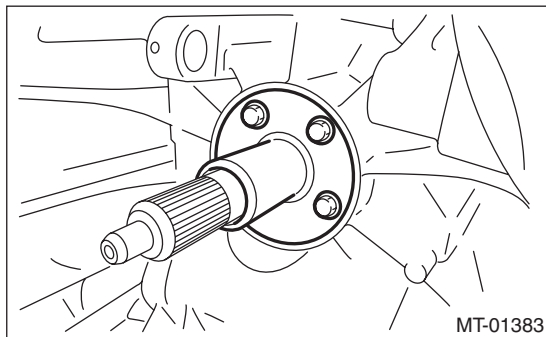

E: INSPECTION

1) Check to make sure there is no damage or cracks on the clutch housing. If there is excessive damage, replace the clutch housing.

2) Inspect the clutch housing for transmission gear oil leakage. If any oil leaks are found, repair or replace the applicable part.

24. Driver's Control Center Differential Control Module

A: REMOVAL

- 1) Disconnect the ground cable from the battery.
- 2) Remove the instrument panel lower. <Ref. to EI-46, INSTRUMENT PANEL LOWER, REMOVAL, Center Console.>
- 3) Remove the driver's control center differential control module by disconnecting the connector.

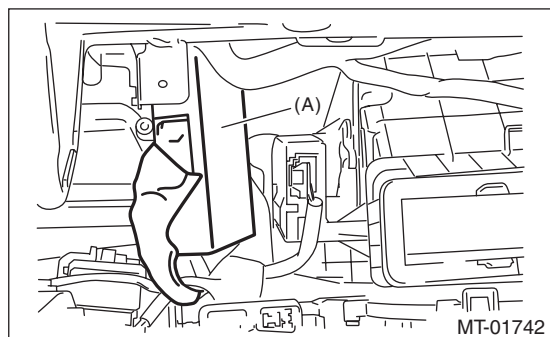

(A) Driver's control center differential control module

B: INSTALLATION

Install in the reverse order of removal.

Tightening torque:

15 N·m (1.5 kgf·m, 11.1 ft·lb)

General Diagnostic Table

MANUAL TRANSMISSION AND DIFFERENTIAL

Brought to you by
Chris Studios
NOT FOR SALE

25. General Diagnostic Table

A: INSPECTION

1. MANUAL TRANSMISSION

Symptom	Possible cause	Corrective action
1. Gears are difficult to engage. NOTE: If it is difficult to shift, there are two possible causes. One is a defective gear shift system and the other is defective transmission. However, if the operation is heavy and engagement of the gears is difficult, a defective clutch function may also be responsible. Check whether the clutch is correctly functioning, before checking the gear shift system and transmission.	(a) Worn, damaged or burred chamfer at internal spline of the sleeve	Replace.
	(b) Gear spline wear, damage, dents	Replace.
	(c) Worn or scratched bushings	Replace.
	(d) Incorrect contact or wear between synchronizer ring and gear cone	Repair or replace.
2. Gear slip-out • Gear slips out when coasting on rough road. • Gear slips out during acceleration.	(a) Defective pitching stopper adjustment	Adjust.
	(b) Loose engine mounting bolts	Tighten or replace.
	(c) Worn fork shifter, broken shifter fork rail spring	Replace.
	(d) Worn or damaged ball bearing	Replace.
	(e) Excessive clearance between splines of synchronizer hub and synchronizer sleeve	Replace.
	(f) Worn in the synchronizer hub chamfer angle	Replace.
	(g) Worn 1st driven gear, needle bearing and race	Replace.
	(h) Worn 2nd driven gear, needle bearing and race	Replace.
	(i) Worn 3rd drive gear and bushing	Replace.
	(j) Worn 4th drive gear and bushing	Replace.
	(k) Worn 5th drive gear and bushing	Replace.
	(l) Worn 6th drive gear and bushing	Replace.
	(m) Worn reverse idler gear and bushing	Replace.
3. Abnormal noise emitted from transmission NOTE: If a noise is heard when the vehicle is parked with its engine idling and ceases when the clutch is disengaged, it may be considered that the noise is coming from the transmission.	(a) Insufficient or improper lubrication	Replenish or replace with the specified amount of recommended oil.
	(b) Worn or damaged gears and bearings NOTE: If the trouble is only wear of the gear teeth surfaces, only a high whirring noise will occur at high speeds, but if any part is broken, rhythmical clicking sounds will be heard even at low speeds.	Replace.

General Diagnostic Table

MANUAL TRANSMISSION AND DIFFERENTIAL

Brought to you by Eris Studios
NOT FOR RESALE

2. DIFFERENTIAL

Symptom	Possible cause	Corrective action
<p>1. Broken differential (case, gear, bearing, etc.)</p> <p>NOTE: Noise will occur, and eventually the differential will not be able to operate due to broken pieces obstructing the gear revolution.</p>	(a) Insufficient or improper oil	Disassemble the differential and replace broken components. At the same time check other components for any trouble, and replace if necessary.
	(b) Use of vehicle under severe conditions such as excessive load and improper use of the clutch	Readjust the preload and backlash of the bearing, and the contact surface of gear.
	(c) Improper adjustment of taper roller bearing	Adjust.
	(d) Improper adjustment of the drive pinion and the hypoid driven gear	Adjust.
	(e) Loose hypoid driven gear clamping bolts	Tighten.
<p>2. Differential and hypoid gear noise</p> <p>Troubles of the differential and hypoid gear always appear as noise problems. Therefore noise is the first indication of trouble. However, noise from the engine, muffler, tire, exhaust gas, bearing, body, etc. are easily mistaken for noise from the differential. Pay special attention to the hypoid gear noise because it is easily confused with other gear noises. There are the following four kinds of noises.</p> <ul style="list-style-type: none"> • Gear noise when driving: If noise increases as the vehicle speed increases, it may be due to insufficient gear oil, incorrect gear engagement, damaged gears, etc. • Gear noise during coasting: Damaged gears due to misadjusted bearings and incorrect shim adjustment. • Bearing noise when driving or coasting: Cracked, broken or damaged bearings. 	(a) Insufficient oil	Replenish or replace with the specified amount of recommended oil.
	(b) Improper adjustment of hypoid driven gear and drive pinion	Check the tooth contact.
	(c) Worn teeth of hypoid driven gear and drive pinion	Replace as a set. Readjust the bearing preload.
	(d) Loose roller bearing	Readjust the backlash of the hypoid driven gear to drive pinion, and check the tooth contact.
	(e) Distorted hypoid driven gear or differential case	Replace.