

Brought to you by Eris Studios  
NOT FOR RESALE

# WIRING

Brought to you by Eris Studios  
NOT FOR RESALE

Brought to you by *Chris Studios*  
 NOT FOR SALE

## 1. Basic Diagnostic Procedure

### A: BASIC PROCEDURES

#### 1. GENERAL DESCRIPTION

The most important purpose of diagnostics is to quickly determine which part is malfunctioning, to save time and labor.

#### 2. IDENTIFICATION OF TROUBLE SYMPTOM

Determine what the problem is based on the symptom.

#### 3. PROBABLE CAUSE OF TROUBLE

Look at the wiring diagram and check the system's circuit. Then check the switch, relay, fuse, ground, etc.

#### 4. LOCATION AND REPAIR OF TROUBLE

- 1) Using the diagnostics, narrow down the causes.
- 2) If necessary, use a voltmeter, ohmmeter, etc.
- 3) Before replacing certain component parts (switch, relay, etc.), check the power supply, ground, for open wiring harness, poor connectors, etc. If no problem is encountered, check the component parts.

#### 5. SYSTEM OPERATION CHECK

After repairing, ensure that the system operates properly.

## B: BASIC INSPECTION

### 1. VOLTAGE MEASUREMENT

- 1) Using a voltmeter, connect the negative lead to a good ground point or negative battery terminal and the positive lead to the connector or component terminal.
- 2) Touch connector (A) with the positive probe of the volt meter. The voltmeter will indicate a voltage.
- 3) Touch connector (B) with the positive probe. The voltmeter will indicate no voltage.

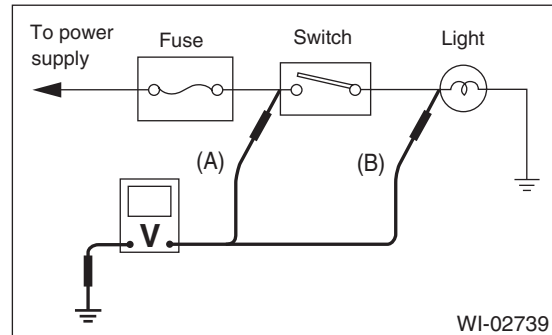

- 4) With the test set-up held as it is, turn the switch to ON. The voltmeter will indicate a voltage and, at the same time, the light will illuminate.
- 5) The circuit is in good order. If a problem such as a light failing to illuminate occurs, use the procedures outlined above to track down the malfunction.

### 2. CIRCUIT CONTINUITY CHECKS

- 1) Disconnect the battery terminal or connector so there is no voltage between the check points. Contact the two leads of an ohmmeter to each of the check points. If the circuit has diodes, reverse the two leads and check again.
- 2) Use an ohmmeter to check for diode continuity. When contacting the negative lead to the diode positive side and the positive lead to the negative side, there should be continuity. When contacting the two leads in reverse, there should be no continuity.

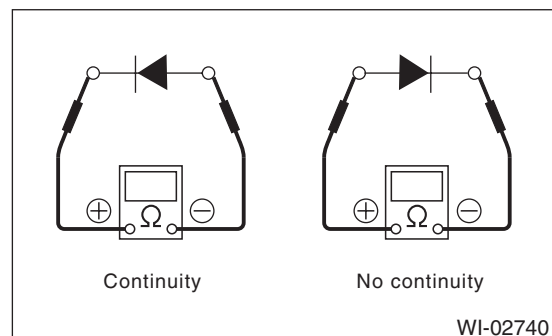

## WIRING SYSTEM

3) The symbol “○ — ○” indicates that continuity exists between two points or terminals. For example, when a switch position is at “3”, continuity exists among terminals 1, 3 and 6, as shown in the table below.

Terminal Switch Position	1	2	3	4	5	6
OFF						
1	○	—			○	○
2	○	—		○		○
3	○		○			○
4	○	○				○

WI-02741

### 3. HOW TO DETERMINE AN OPEN CIRCUIT

#### 1) WITH VOLTMETER:

An open circuit is determined by measuring the voltage between respective connectors and ground using a voltmeter, starting with the connector closest to the power supply. The power supply must be turned ON so that current flows in the circuit. If voltage is not present between a particular connector and ground, the circuit between that connector and the previous connector is open.

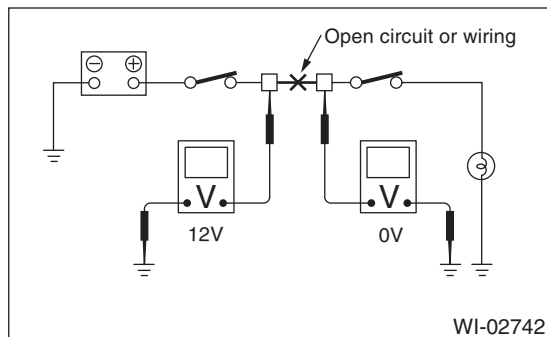

#### 2) WITH OHMMETER:

Disconnect all connectors affected, and check continuity in the wiring between adjacent connectors. When the ohmmeter indicates “infinite”, the wiring is open.

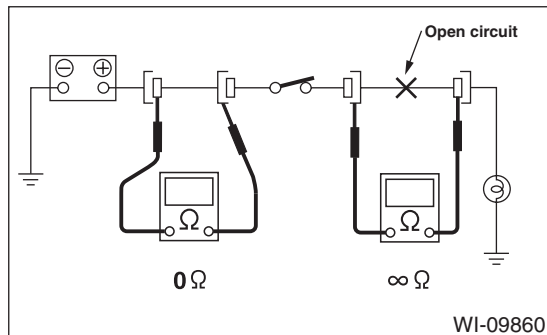

### 4. HOW TO DETERMINE A SHORT CIRCUIT

#### 1) WITH TEST LIGHT:

Connect a test light (rated at approx. 3 watts) in place of the blown fuse and allow current to flow through the circuit. Disconnect one connector at a time from the circuit. Starting with the one located farthest from the power supply. If the test light goes out when a connector is disconnected, the wiring between that connector and the next connector (farther from the power supply) is shorted.

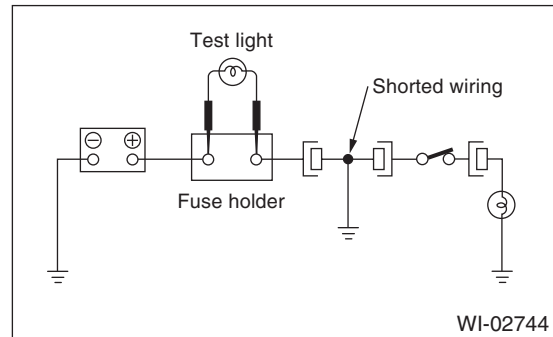

#### 2) WITH OHMMETER:

Disconnect all affected connectors, and check continuity between each connector and ground. When the ohmmeter indicates continuity between a particular connector and a ground, that connector is shorted.

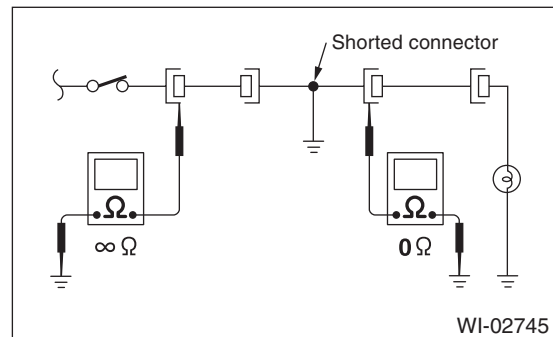

## C: HOW TO READ WIRING DIAGRAMS

### 1. WIRING DIAGRAM:

The wiring diagram of each system is illustrated so that you can understand the path through which the electric current flows from the battery.

Sketches and codes are used in the diagrams. They should read as follows:

- Each connector and its terminal position are indicated by a sketch of the connector in a disconnected state which is viewed from the front.

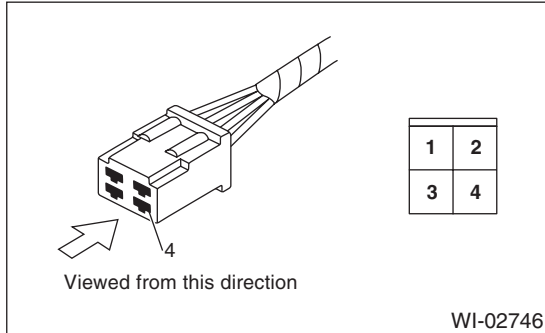

- The number of poles or pins, presence of a lock are indicated in the sketch of each connector. In the sketch, the highest pole number, refers to the number of poles which the connector has. For example, the sketch of the connector shown in figure indicates the connector has 9 poles.

Connector used in vehicle	Connector shown in wiring diagram		
	Sketch	Symbol	Number of poles
	<p>Double frames</p> <p>Indicates a lock is included.</p> <p>Indicates the number of poles.</p>		Numbered in order from upper right to lower left
	<p>Indicates a lock is included.</p> <p>Single frame</p>		Numbered in order from upper left to lower right

WI-02747

# Basic Diagnostic Procedure

Brought to you by Eris Studios  
NOT FOR RESALE

## WIRING SYSTEM

- When one set of connectors is viewed from the front side, the pole numbers of one connector are symmetrical to those of the other. When these two connectors are connected as a unit, the poles which have the same number are joined.

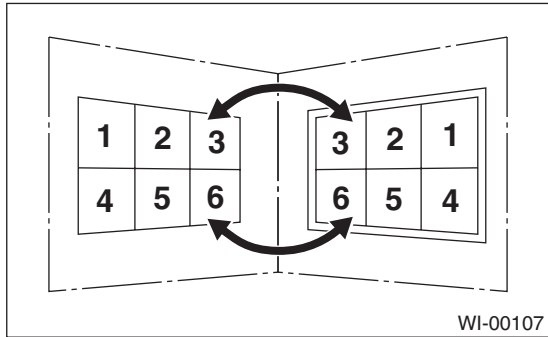

### • WIRING DIAGRAM:

The connectors are numbered along with the number of poles, external colors, and mating connections in the accompanying list.

- The sketch of each connector in the wiring diagram usually shows the (A) side of the connector. The relationship between the wire color, terminal number and connector is described in the figure.

### NOTE:

A wire which runs in one direction from a connector terminal sometimes may have a different color from that which runs in the other direction from that terminal.

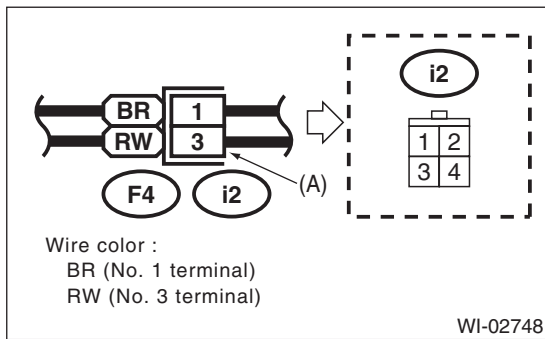

- In the wiring diagram, connectors which have no terminal number refer to one-pole types. Sketches of these connectors are omitted intentionally.

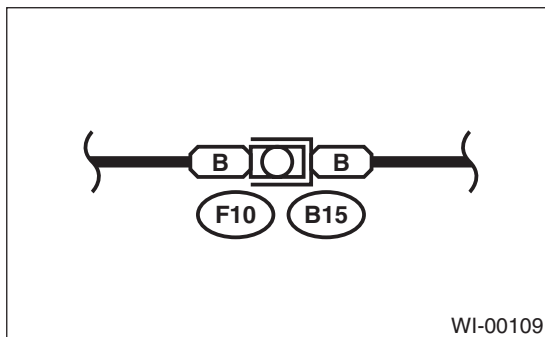

- The following color codes are used to indicate the colors of the wires.

Color code	Color
L	Blue
B	Black
Y	Yellow
G	Green
R	Red
W	White
Br	Brown
Lg	Light green
Gr	Gray
P	Pink
Or	Orange
Sb	Light blue
V	Violet
SA	Sealed (Inner)
SB	Sealed (Outer)

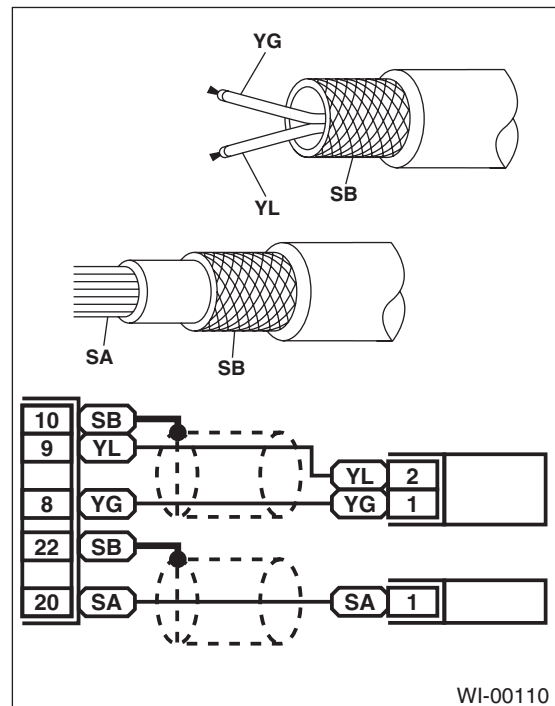

Brought to you by *Chris Studios*  
 NOT FOR SALE

- The wire color code, which consists of two letters (or three letters including Br or Lg), indicates the standard color (base color of the wire covering) by its first letter and the stripe marking by its second letter.

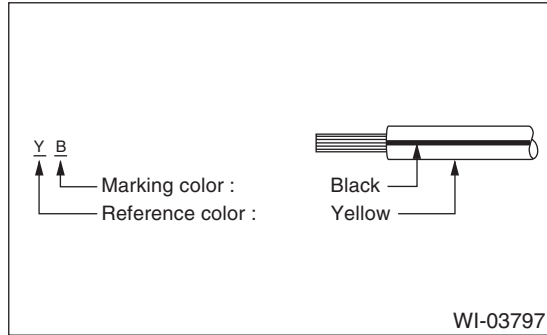

- The table lists the nominal sectional areas and allowable currents of the wires.

**CAUTION:**

**When replacing or repairing a wire, be sure to use the same size and type of the wire which was originally used.**

**NOTE:**

- The allowable current in the table indicates the tolerable amperage of each wire at an ambient temperature of 40°C (104°F).
- The allowable current changes with ambient temperature. Also, it changes if a bundle of more than two wires is used.

Nominal sectional area mm <sup>2</sup>	No. of strands/ strand diameter	Outside diameter of wiring mm	Allowable current Amps/ 40°C (104°F)
0.3	7/0.26	1.8	7
0.5	7/0.32	2.2 (or 2.0)	12
0.75	30/0.18	2.6 (or 2.4)	16
0.85	11/0.32	2.4 (or 2.2)	16
1.25	16/0.32	2.7 (or 2.5)	21
2	26/0.32	3.1 (or 2.9)	28
3	41/0.32	3.8 (or 3.6)	38
5	65/0.32	4.6 (or 4.4)	51
8	50/0.45	5.5	67

- Each unit is either directly grounded to the body or indirectly grounds through a harness ground terminal. Different symbols are used in the wiring diagram to identify the two grounding systems.

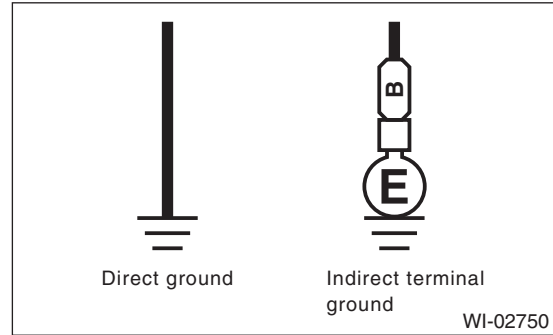

- The ground points shown in the wiring diagram refer to the following:

**NOTE:**

All wiring harnesses are provided with a ground point which must be securely connected.

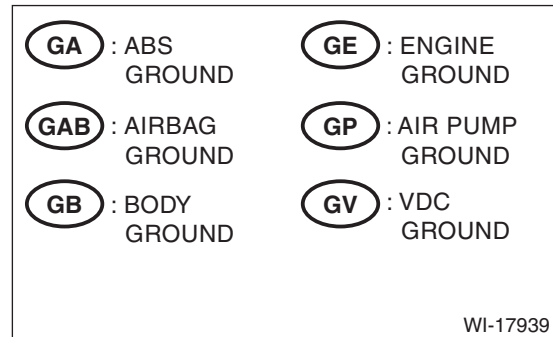

# Basic Diagnostic Procedure

Brought to you by Eris Studios  
NOT FOR RESALE

## WIRING SYSTEM

- Relays are classified as normally-open or normally-closed.
- The normally-closed relay has one or more contacts. The wiring diagram shows the relay mode when the energizing circuit is OFF.

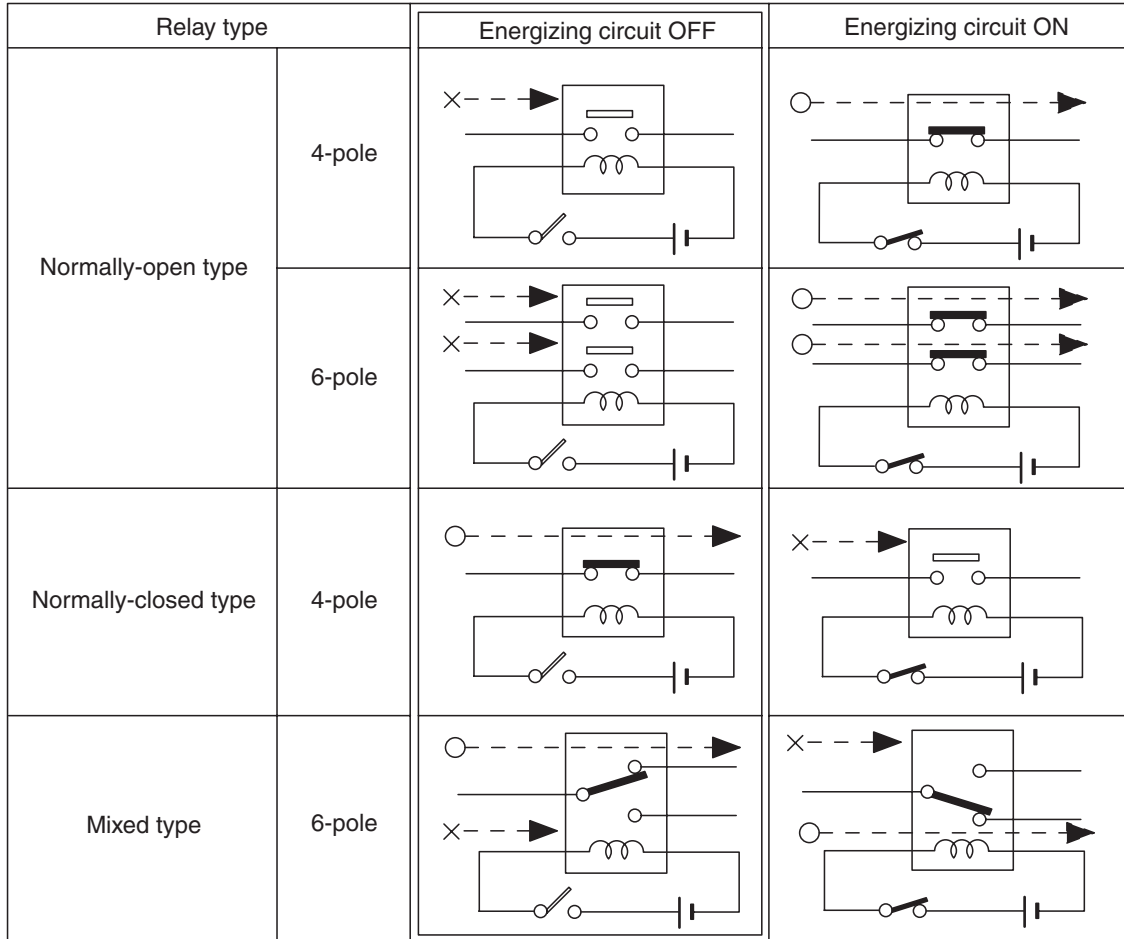

Key to symbols:

- —▶ : Current flows.
- × —▶ : Current does not flow.

WI-16724



- Each connector number shown in the wiring diagram corresponds to that in the wiring harness. The location of each connector in the actual vehicle is determined by reading the first character of the connector (for example, a "F" for F8, "i" for i16, etc.) and the type of wiring harness. The first character of each connector number corresponds to the area or system of the vehicle.

Symbol	Wiring harness and cord
F	Front wiring harness
B	Bulkhead wiring harness
E	Engine wiring harness
T	Transmission cord
D	Door cord LH & RH, Rear gate cord Rear door cord LH & RH, Rear defogger cord
i	Instrument panel wiring harness
R	Rear wiring harness, Fuel tank cord, Roof cord, Rear gate cord
AB	Airbag wiring harness

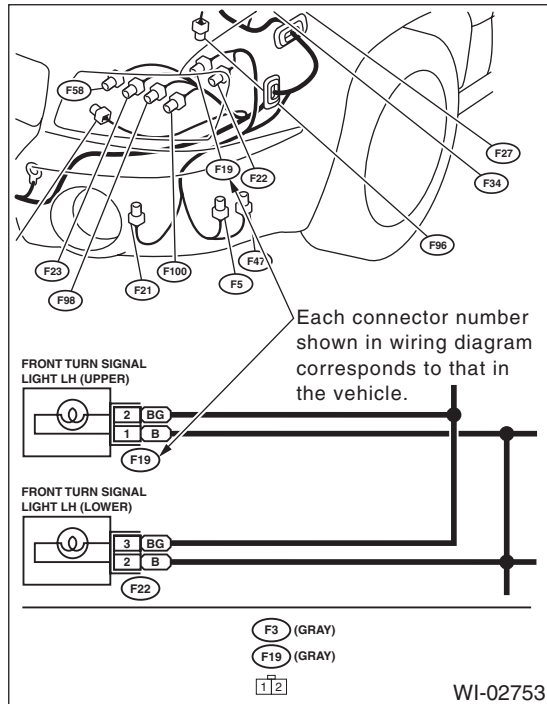

# Basic Diagnostic Procedure

Brought to you by Eris Studios  
NOT FOR SALE

## WIRING SYSTEM

### D: SYMBOLS IN WIRING DIAGRAMS

A number of symbols are used in each wiring diagram to easily identify parts or circuits.

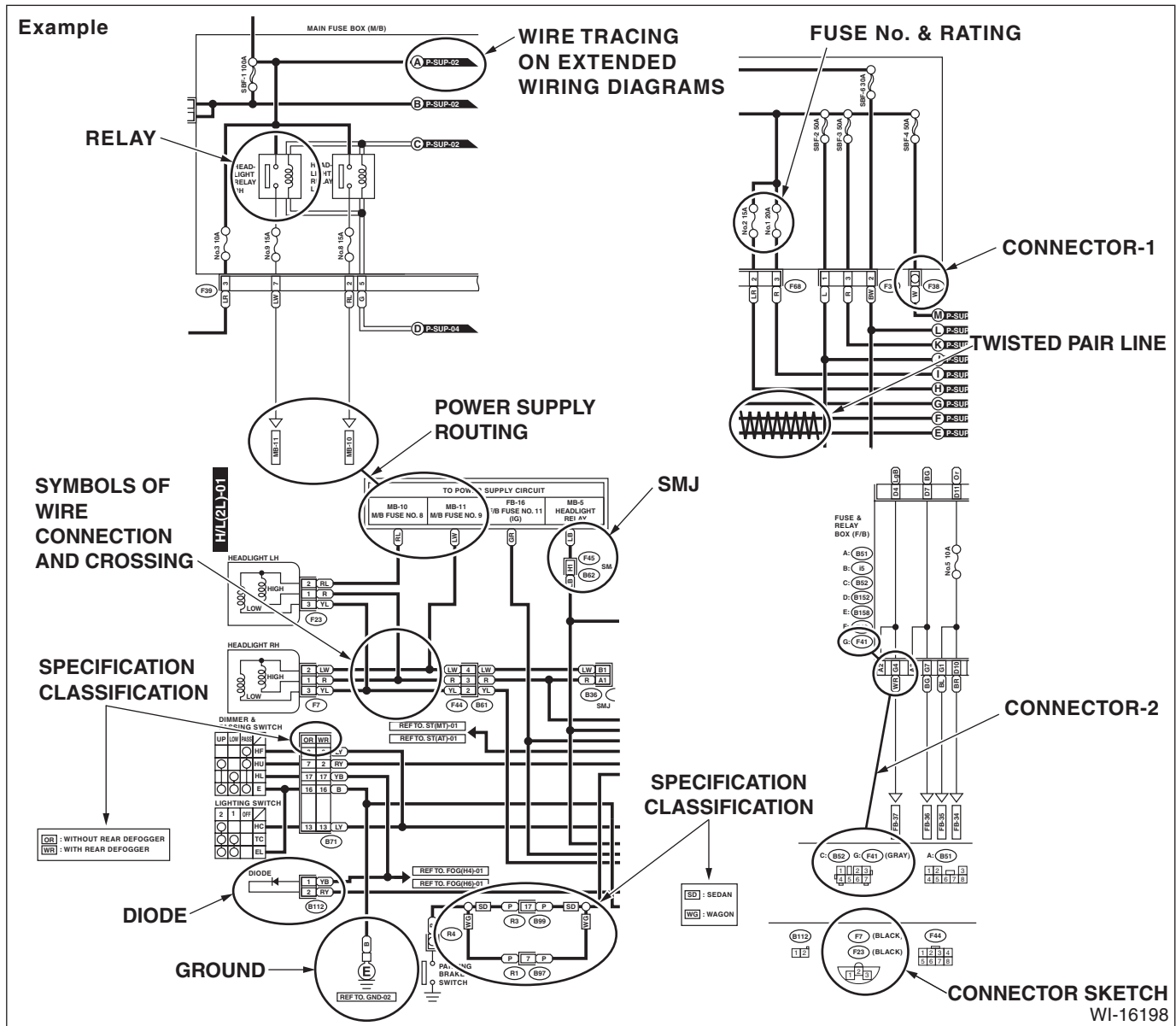

Brought to you by *Chris Studios*  
NOT FOR SALE

### 1. RELAY

A symbol used to indicate a relay.

### 2. CONNECTOR 1

The sketch of the connector indicates the one-pole types.

### 3. WIRING CONNECTION

Some wiring diagrams are indicated in foldouts for convenience. Wiring destinations are indicated where necessary by corresponding symbols. (When two pages are needed for clear indication)

### 4. FUSE NO. & RATING

The "FUSE No. & RATING" corresponds with that used in the fuse box (main fuse box, fuse and joint box).

### 5. CONNECTOR 2

- Each connector is indicated by a symbol.
- Each terminal number is indicated in the corresponding wiring diagram in an abbreviated form.
- For example, terminal number "G4" refers to No. 4 terminal of connector (G: F41) shown in the connector sketch.

### 6. CONNECTOR SKETCH

- Each connector sketch clearly identifies the shape and color of a connector as well as terminal locations. Non-colored connectors are indicated in natural color.
- When more than two types of connector number are indicated in a connector sketch, it means that the same type connectors are used.

### 7. GROUND

Each grounding point can be located easily by referring to the corresponding wiring harness.

### 8. DIODE

A symbol is used to indicate a diode.

### 9. WIRE TRACING ON EXTENDED WIRING DIAGRAMS

For a wiring diagram extending over at least two pages, a symbol (consisting of the same characters with arrows), facilitates wire tracing from one page to the next.

A ↔ A, B ↔ B

### 10. SYMBOLS OF WIRE CONNECTION AND CROSSING

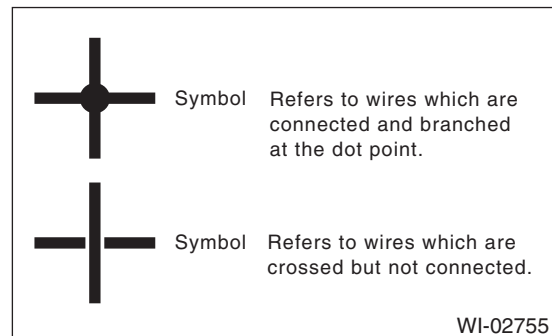

### 11. POWER SUPPLY CIRCUIT

A symbol is used to indicate the power supply in each wiring diagram.

"MB - 5", "MB - 6", etc., which are used as power-supply symbols throughout the text, correspond with those shown in the "DC POWER SUPPLY CIRCUIT" in the wiring diagram.

Accordingly, using the "DC POWER SUPPLY CIRCUIT" and wiring diagrams permits service personnel to understand the entire electrical arrangement of a system.

### 12. CLASSIFICATION BY SPECIFICATION

When the wiring diagram differ according to vehicle specifications, the specification difference is described by using abbreviations.

### 13. TWISTED PAIR LINE

The twisted pair line is indicated by a symbol in the wiring diagrams.

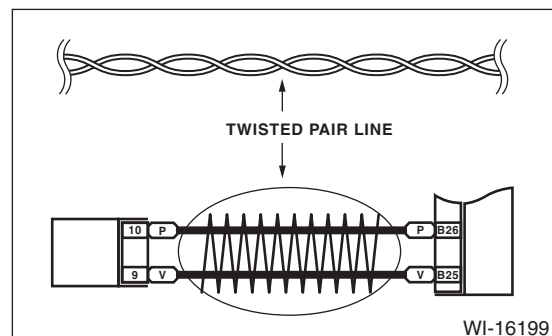











# Basic Diagnostic Procedure

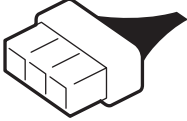



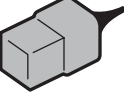
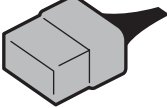
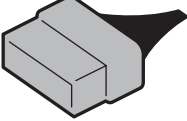







WIRING SYSTEM

Brought to you by Eris Studios  
NOT FOR RESALE

## E: CONNECTOR SYMBOL IN WIRING HARNESS

A number of connector symbols are used in each wiring diagram to easily identify the wiring harness connectors.

Standard type: Female		
Pole: From 1 to 8	Pole: From 9 to 20	Pole: More than 21
		
		
Standard type: Male		
		
		

Water proof type: Female		
Pole: From 1 to 8	Pole: From 9 to 20	Pole: More than 21
		
		
Water proof type: Male		
		
		

WI-02756

Brought to you by **Chris Studios**  
NOT FOR RESALE

## F: ABBREVIATION IN WIRING DIAGRAMS

Abbr.	Full name
ABS	Anti-lock Brake System
ACC	Accessory
A/C	Air Conditioner
ASSY	Assembly
AT	Automatic Transmission
A/F	Air/Fuel (Air fuel ratio sensor)
ATF	Automatic Transmission Fluid
AUX	Audio External Input Terminal
AWD	All Wheel Drive
B	Battery
CAN	Controller Area Network
D	Drive range or Down
DN	Down
E	Ground
ECM	Engine Control Module
EEPROM	Electric Erasable Programmable Read Only Memory
EGR	Exhaust Gas Recirculation
F/B	Fuse & Relay Box
FL	Front Left Hand
FR	Front Right Hand
FWD	Front Wheel Drive
G	Gravity (G sensor)
H/L	Headlight
HI	High
I/F	Interface
IG	Ignition
Illumi	Illumination
INT	Intermittent
LCD	Liquid Crystal Display
LH	Left Hand
LO	Low
M	Motor
M/B	Main Fuse Box
MT	Manual Transmission
N	Neutral Range
NA	Natural Aspiration
NAVI	Navigation
OP	Open
P	Parking Range
PASS	Passing
PCV	Positive Crankcase Ventilation Valve
R	Reverse Range
RH	Right Hand
RL	Rear Left
RR	Rear Right
SBF	Slow Blow Fuse
ST	Starter

Abbr.	Full name
SW	Switch
TCM	Transmission Control Module
TPM	Tire Pressure Monitor
U	Up
VDC	Vehicle Dynamics Control
VFD	Vacuum Fluorescent Display
WASH	Washer

## 2. Working Precautions

### A: PRECAUTIONS WHEN WORKING WITH THE PARTS MOUNTED ON THE VEHICLE

- 1) When working under a vehicle which is jacked-up, always be sure to use rigid rack.
- 2) The parking brake must always be applied during working. Also, in automatic transmission vehicles, keep the select lever set to the P (Parking) range.
- 3) Be sure the workshop is properly ventilated when running the engine. Further, be careful not to touch the belt or fan while the engine is operating.
- 4) Be careful not to touch hot metal parts, especially the radiator and exhaust system immediately after the engine has been turned off.

### B: PRECAUTIONS IN TROUBLE DIAGNOSIS AND REPAIR OF ELECTRIC PARTS

- 1) The battery cable must be disconnected from the battery's (-) terminal, and the ignition switch must be set to the OFF position, unless otherwise required by the diagnostics.
- 2) Securely fasten the wiring harness with clamps and clips so that the harness does not interfere with the body end parts, edges, bolts or screws.
- 3) When installing parts, be careful not to catch them on the wiring harness.
- 4) When disconnecting a connector, do not pull the wires, but pull while holding the connector body.

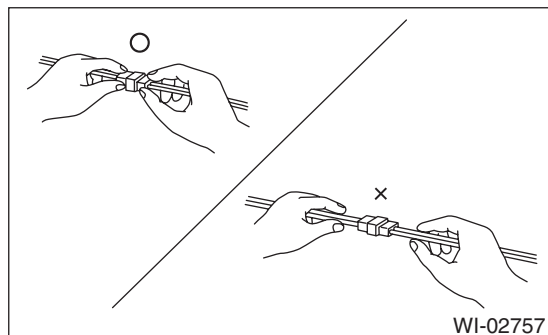

- 5) Some connectors are provided with a lock. One type of such a connector is disconnected by pushing the lock, and the other, by moving the lock up. In either type the lock shape must be identified before attempting to disconnect the connector. To connect, insert the connector until it snaps and confirm that it is connected securely.

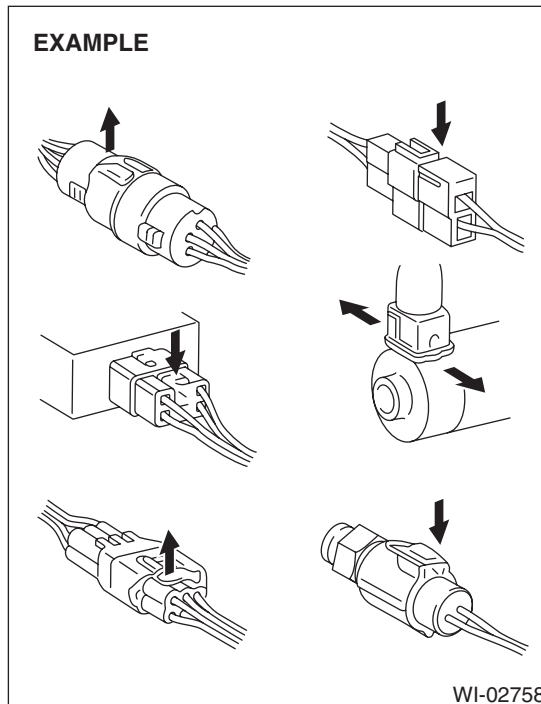

- 6) When checking continuity between connector terminals, or measuring voltage across the terminal and ground, always touch tester probe(s) to terminals from the wiring connection side. If the probe is too thick to gain access to the terminal, use "mini" test leads.

To check water-proof connectors (which are not measurable from the wiring side), touch test probes on the terminal side and be careful not to bend or damage the terminals.

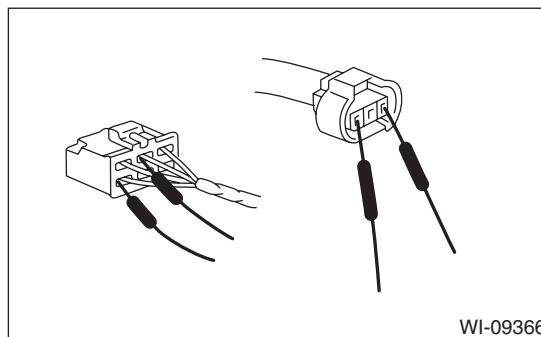

- 7) Sensors, relays, electrical unit, etc., are sensitive to strong impacts. Handle them with care so that they are not dropped or mishandled.

## 3. Power Supply Circuit

### A: WIRING DIAGRAM

P-SUP-01

P-SUP-01

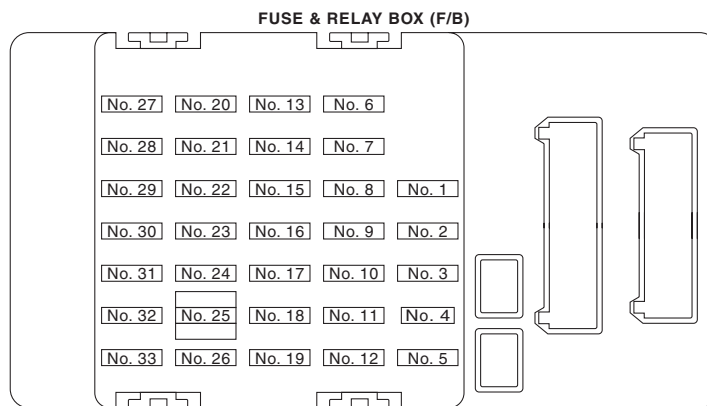
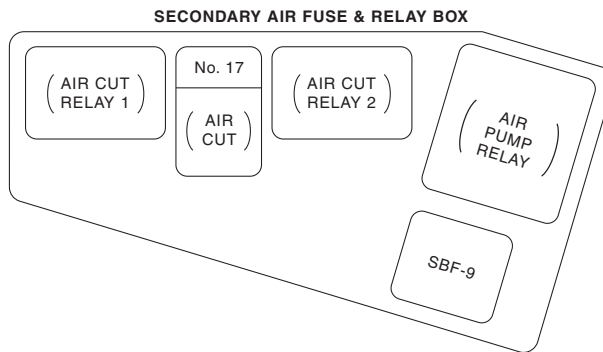
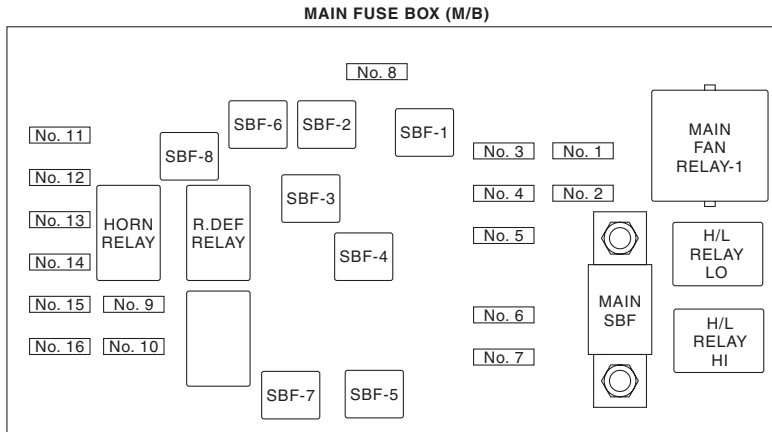

# Power Supply Circuit

Brought to you by Eris Studios  
NOT FOR RESALE

## WIRING SYSTEM

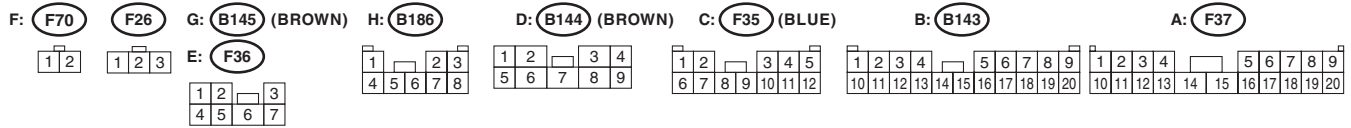
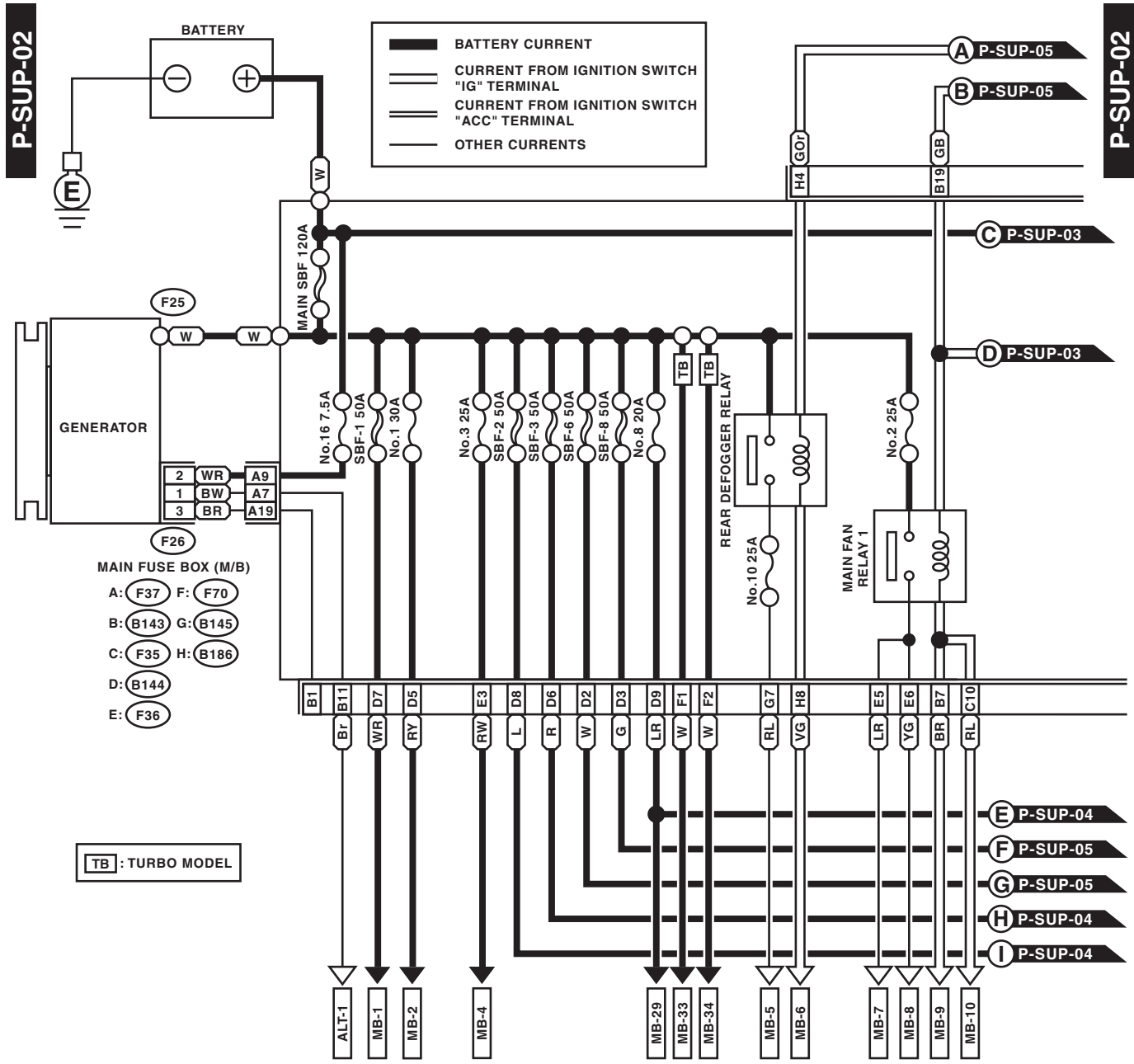

WI-16854



# Power Supply Circuit

WIRING SYSTEM

Brought to you by  
 NOT FOR SALE  
 Chris Studios

P-SUP-03

P-SUP-03

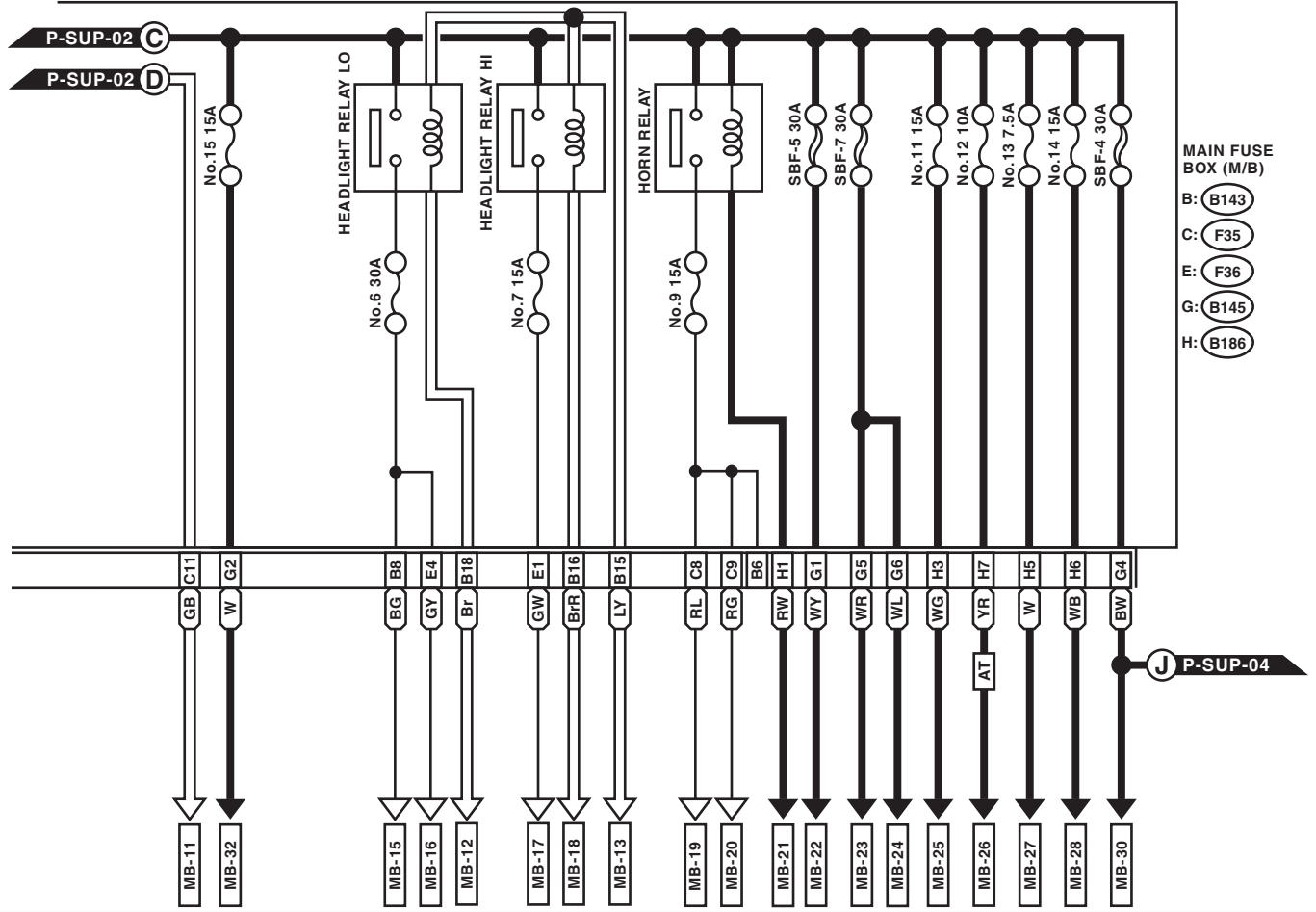

G: B145 (BROWN)

H: B186

C: F35 (BLUE)

B: B143

E: F36

1	2	3
4	5	6
7		

1	2	3
4	5	6
7	8	

1	2	3	4	5
6	7	8	9	10
11	12			

1	2	3	4	5	6	7	8	9
10	11	12	13	14	15	16	17	18
19	20							

WI-16855

# Power Supply Circuit

Brought to you by Eris Studios  
NOT FOR RESALE

WIRING SYSTEM

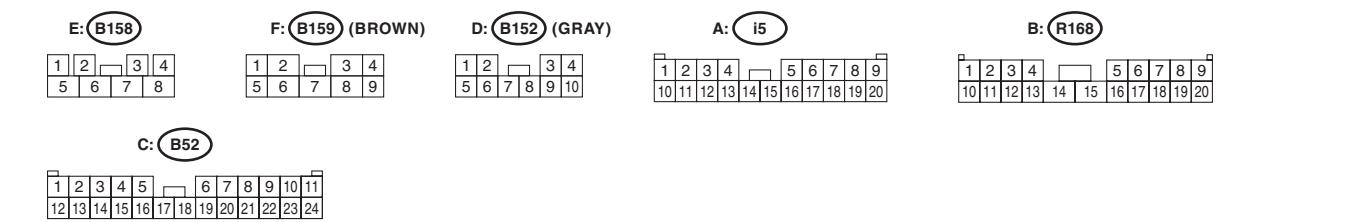
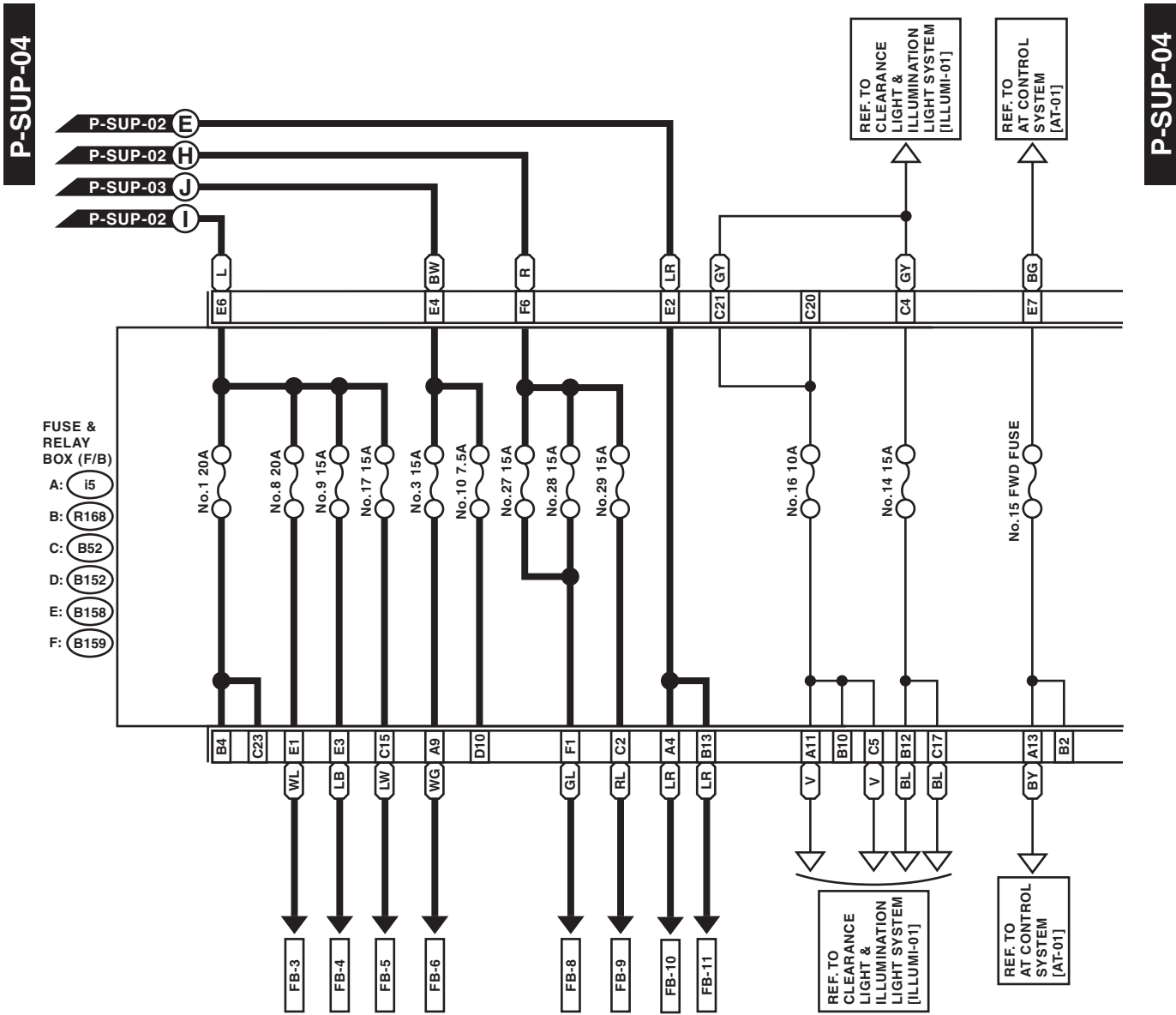

WI-16856

# Power Supply Circuit

WIRING SYSTEM

Brought to you by *Chris Studios*  
NOT FOR SALE

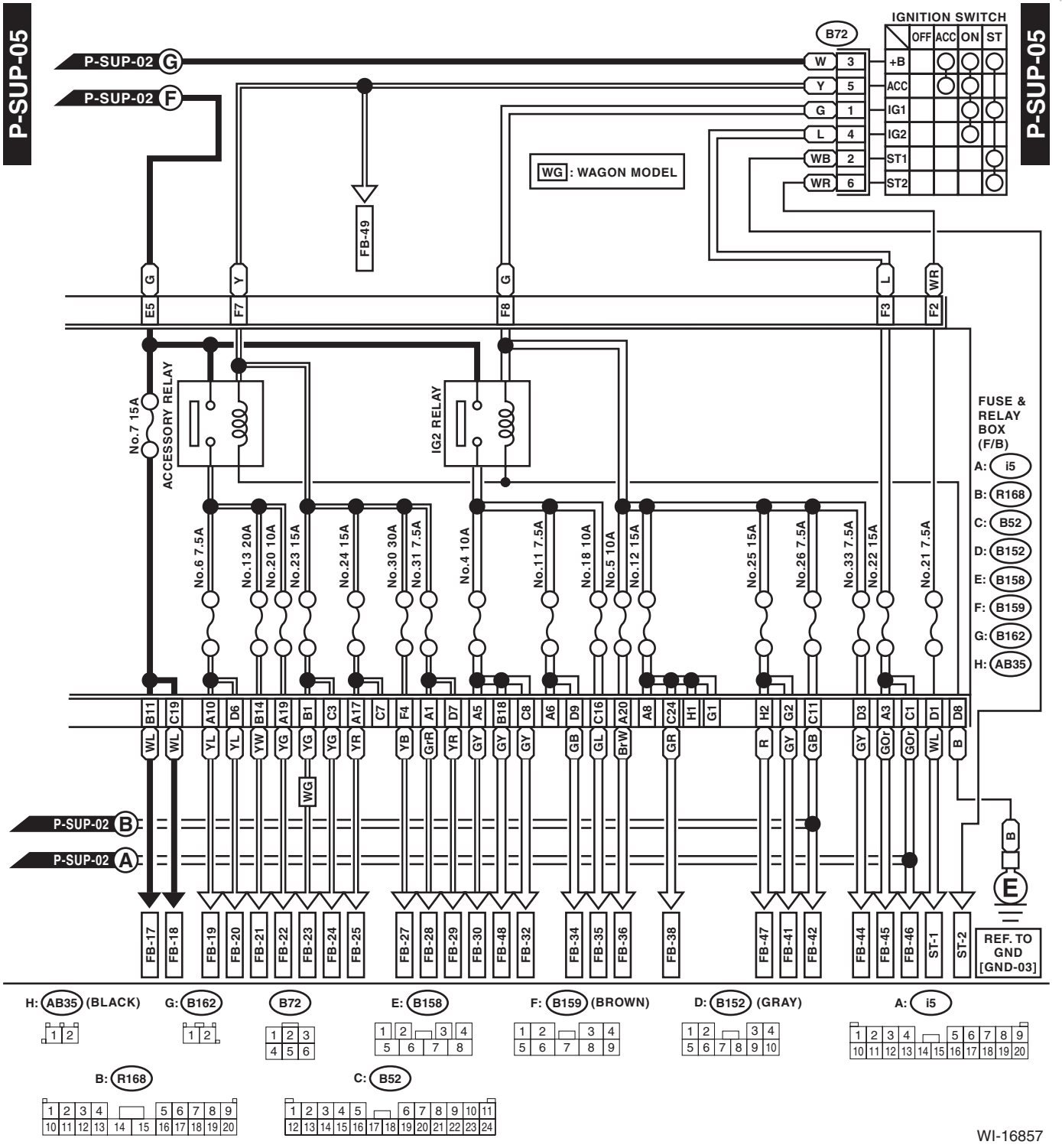

WI-16857

# Power Supply Circuit

Brought to you by Eris Studios  
NOT FOR RESALE

## WIRING SYSTEM

No.	Load
MB-1	ABS control module
	VDC control module
MB-2	ABS control module
	VDC control module
MB-4	Sub fan relay
MB-5	Mirror heater LH
	Mirror heater RH
	Rear defogger
	A/C control panel
MB-6	Body integrated unit
MB-7	Main fan relay 2
MB-8	Main fan motor
MB-9	ECM
MB-10	Main fan relay 2
MB-11	Main fan relay 2
MB-12	Body integrated unit
MB-13	Body integrated unit
MB-15	Front fog light relay
MB-16	Headlight LH (LO)
	Headlight RH (LO)
MB-17	Headlight LH (HI)
	Headlight RH (HI)
	Daytime running light relay
MB-18	Body integrated unit
MB-19	Horn
MB-20	Horn
MB-21	Horn switch
	Body integrated unit
	Remote engine start control module
MB-22	A/F, oxygen sensor relay
MB-23	Main relay
	IG relay
MB-24	Electronic throttle control relay
MB-25	Fuel pump relay
MB-26	TCM
MB-27	ECM
	Data link connector
MB-28	Key illumination
	Key warning switch
	Turn signal and hazard unit
	Body integrated unit
MB-29	Spot map light
	Room light
	Body integrated unit
MB-30	Power window circuit breaker
MB-32	Tail and illumination relay
	Daytime running light relay
	Body integrated unit
MB-33	Secondary air pump relay

No.	Load
MB-34	Secondary air combination valve relay 1
	Secondary air combination valve relay 2
ALT-1	Combination meter
ST-1	Clutch switch
	ECM
	Starter relay
ST-2	Starter relay
FB-3	Stop light & brake switch
FB-4	Wiper deicer relay
FB-5	Seat heater relay
FB-6	Body integrated unit
FB-8	Blower motor relay
FB-9	Front fog light relay
FB-10	Audio
	Clock
FB-11	Keyless entry control module
	Trunk room light (Sedan model)
	Luggage room light (Wagon model)
FB-17	A/C control panel
	Combination meter
	TPM control module
FB-18	Body integrated unit
	Impact sensor
	Mode door actuator
	Air mix door actuator
FB-19	Remote control mirror switch
FB-20	Seat heater relay
	Compass mirror
FB-21	Rear accessory power supply socket
FB-22	Front accessory power supply socket
FB-23	Rear wiper motor
FB-24	Body integrated unit
	Rear washer motor
FB-25	Audio
	Clock
FB-27	Combination switch
	Front wiper motor
FB-28	A/C control panel
FB-29	Body integrated unit
FB-30	Navigation unit
FB-32	ECM
	Clutch switch
	Impact sensor
	Data link connector
	Stop light & brake switch
	Wiper deicer relay
FB-34	Turn signal and hazard unit
FB-35	Inhibitor switch
	Back-up light switch

# Power Supply Circuit

WIRING SYSTEM

Brought to you by  
NOT FOR SALE  
Chris Studios

No.	Load
FB-36	Combination meter
	Clock
FB-38	ECM
	TCM
	Body integrated unit
	Fuel pump relay
	Ignition coil No. 1
	Ignition coil No. 2
	Ignition coil No. 3
	Ignition coil No. 4
FB-41	Airbag control module
FB-42	Power window relay
FB-44	ABS control module
	VDC control module
FB-45	A/C control panel
FB-46	A/C relay
	Intake door actuator
	Sub fan relay
	Pressure switch
	Blower motor relay
FB-47	Occupant detection control module
FB-48	TPM control module
FB-49	Front washer motor

## WIRING SYSTEM

### 4. Ground Circuit

#### A: WIRING DIAGRAM

##### 1. TRANSMISSION SERIAL NO. 4078112 OR EARLIER

- Body ground

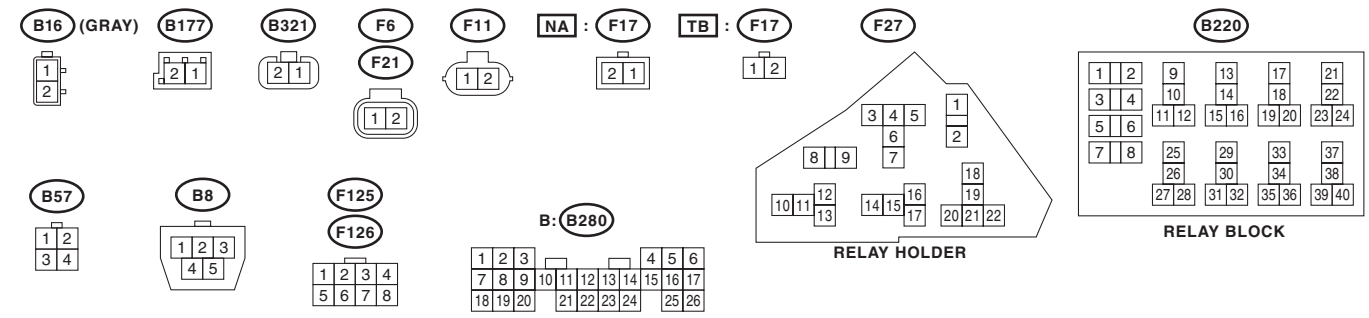
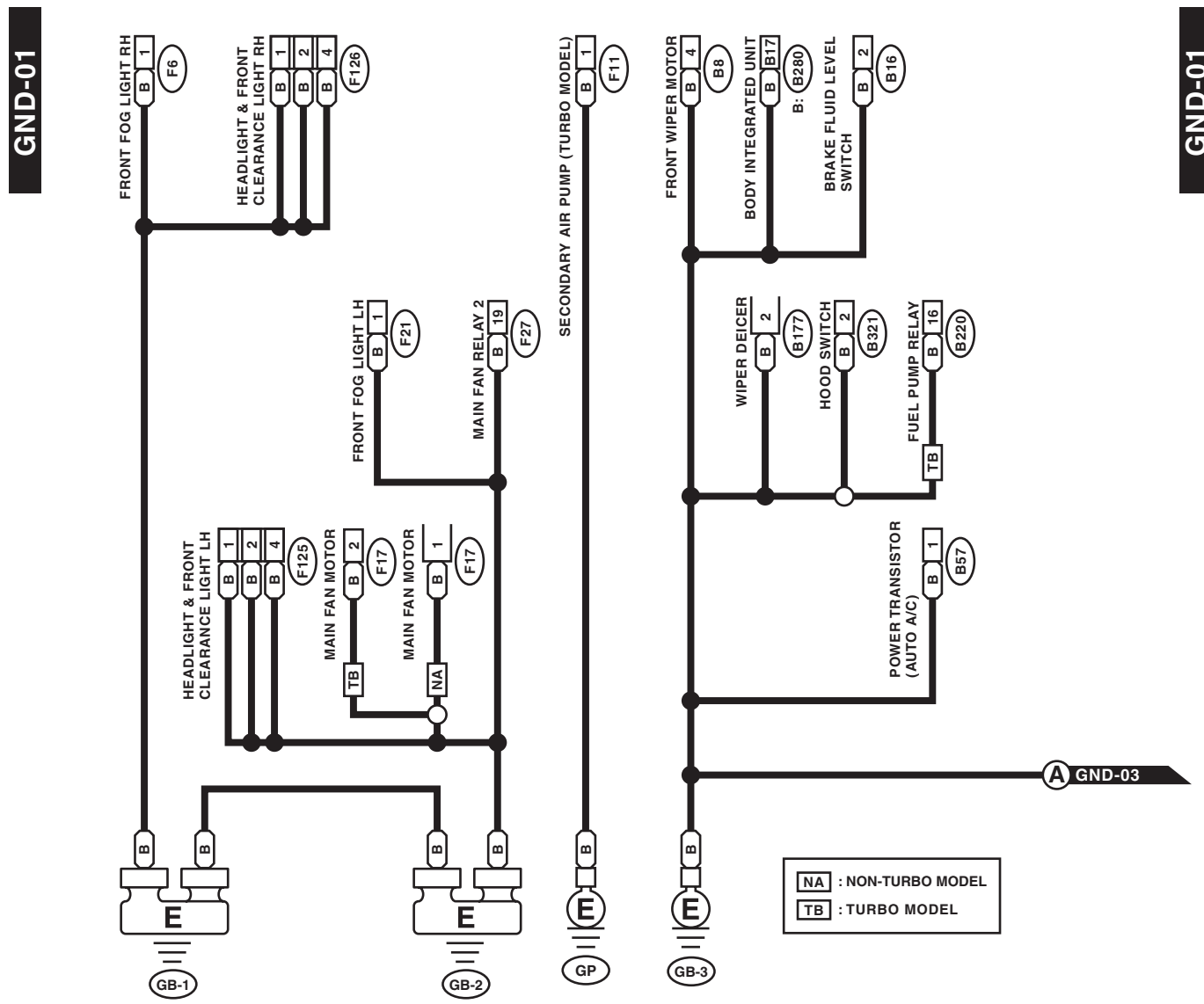

WI-16858

# Ground Circuit

WIRING SYSTEM

Brought to you by *Chris Studios*  
NOT FOR SALE

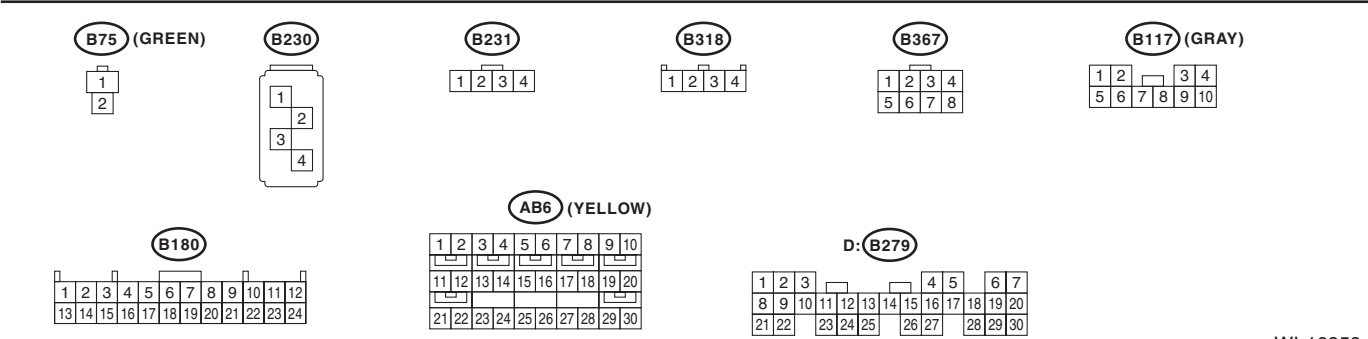
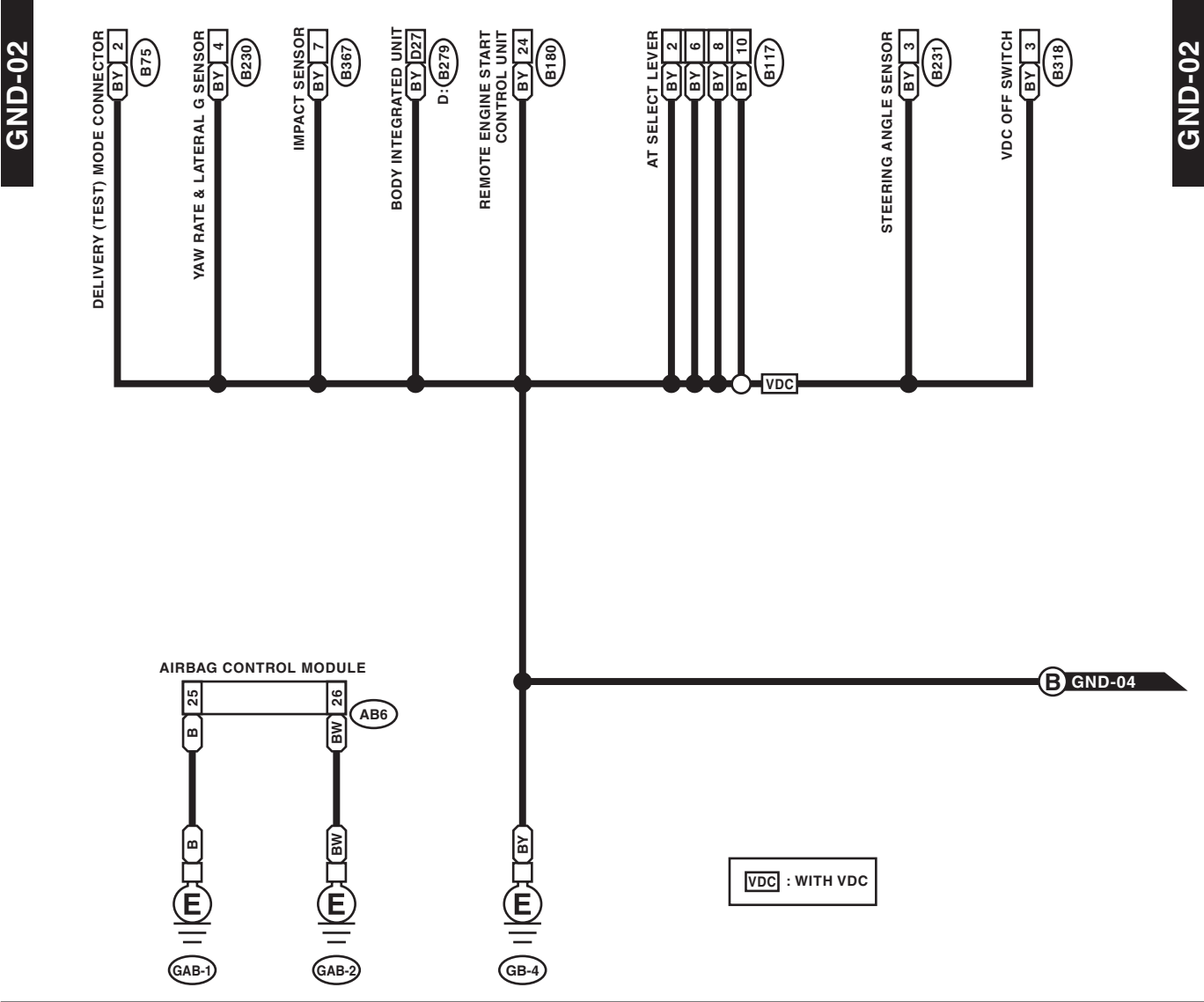

WI-16859

# Ground Circuit

Brought to you by Eris Studios  
NOT FOR RESALE

WIRING SYSTEM

**GND-03**

**GND-03**

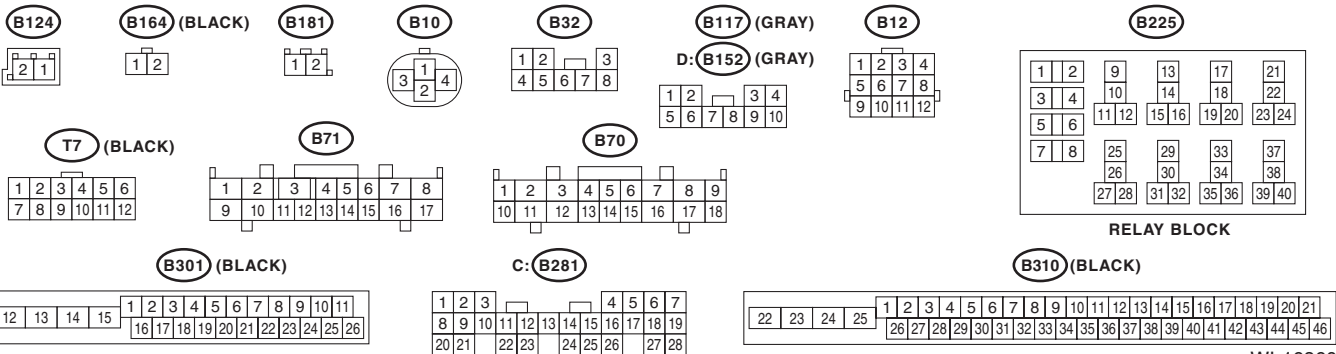
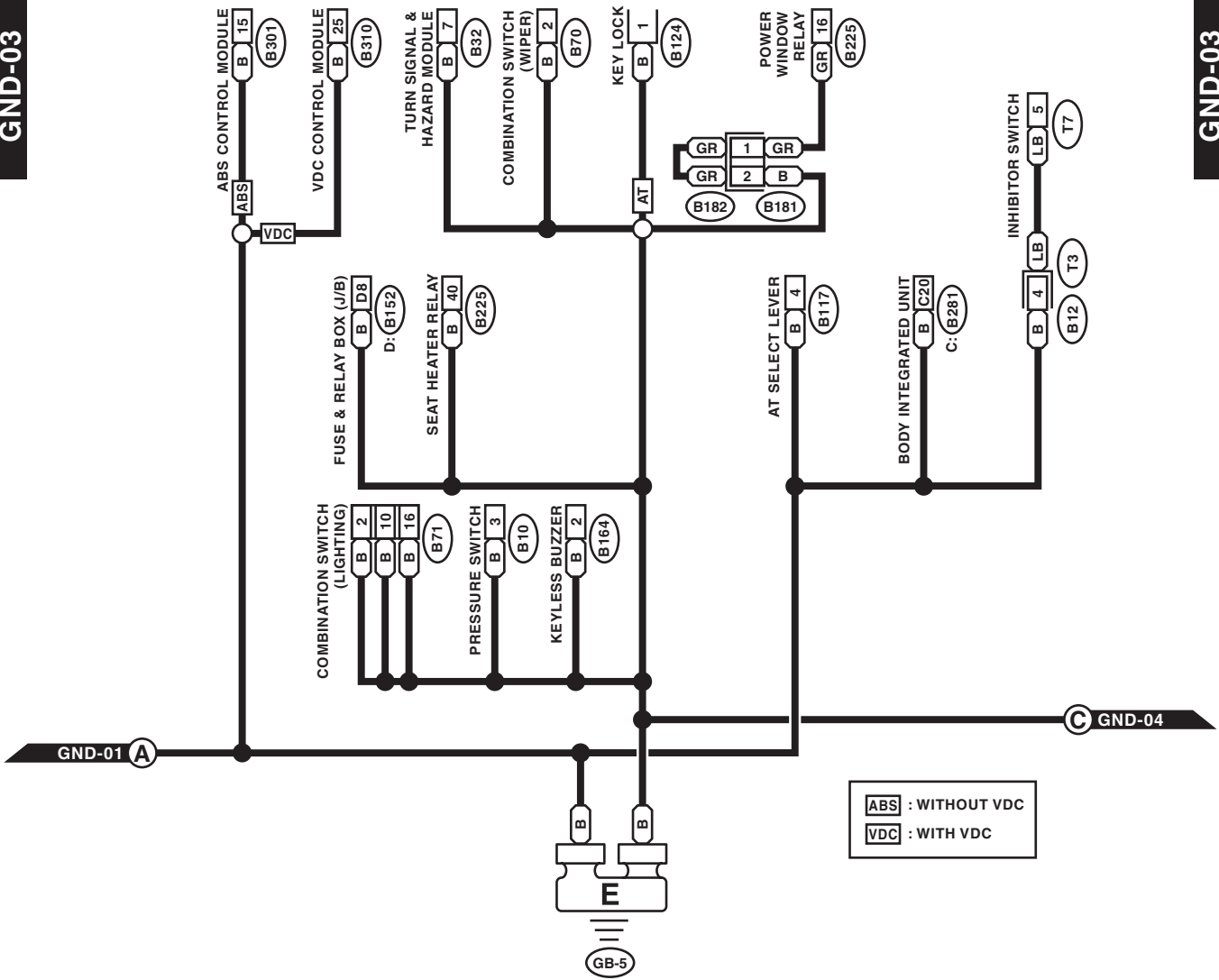

WI-16860



# Ground Circuit

WIRING SYSTEM

Brought to you by *Chris Studios*  
 NOT FOR SALE

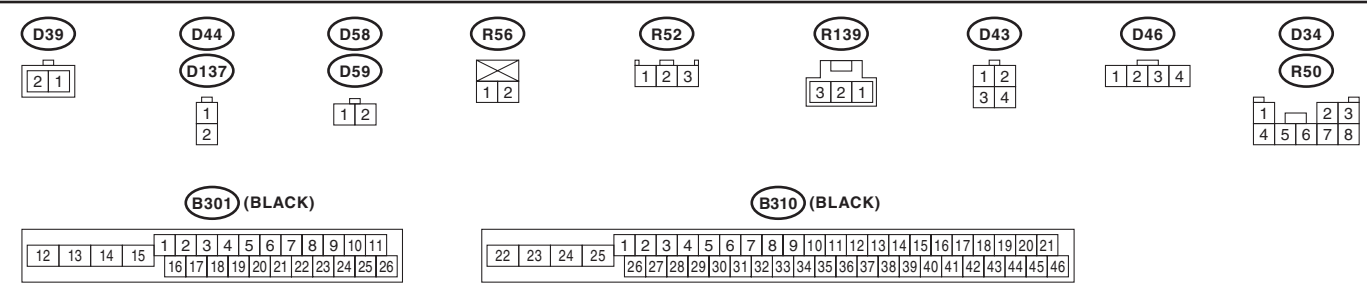
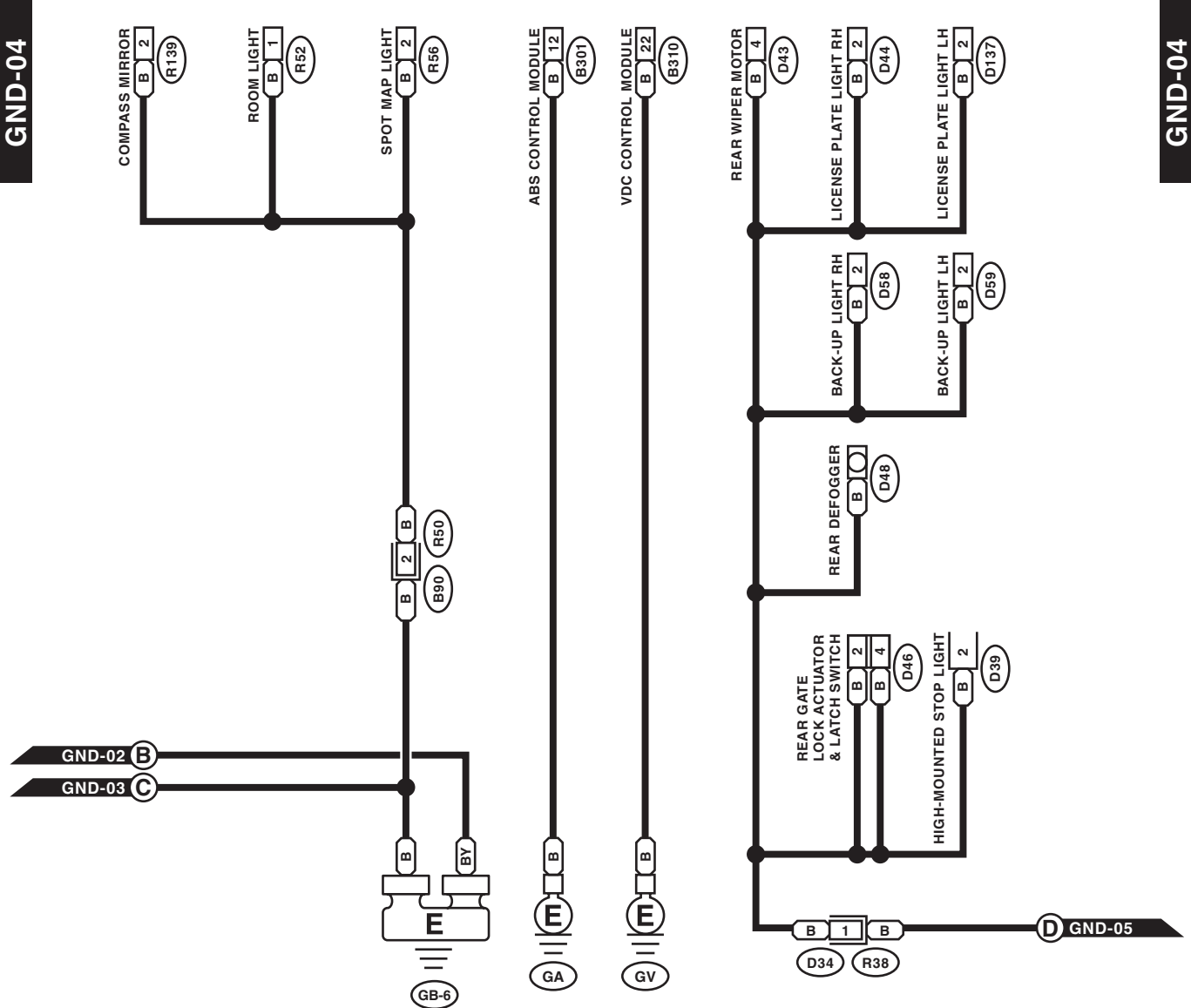

WI-16861

# Ground Circuit

Brought to you by Eris Studios  
NOT FOR RESALE

## WIRING SYSTEM

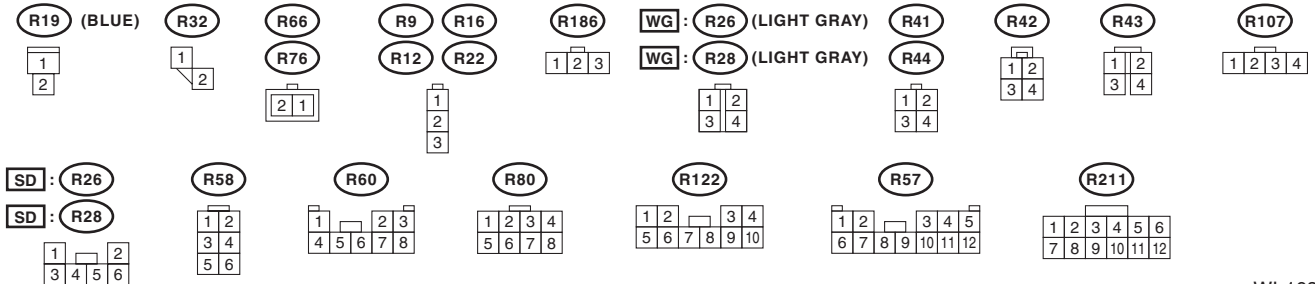
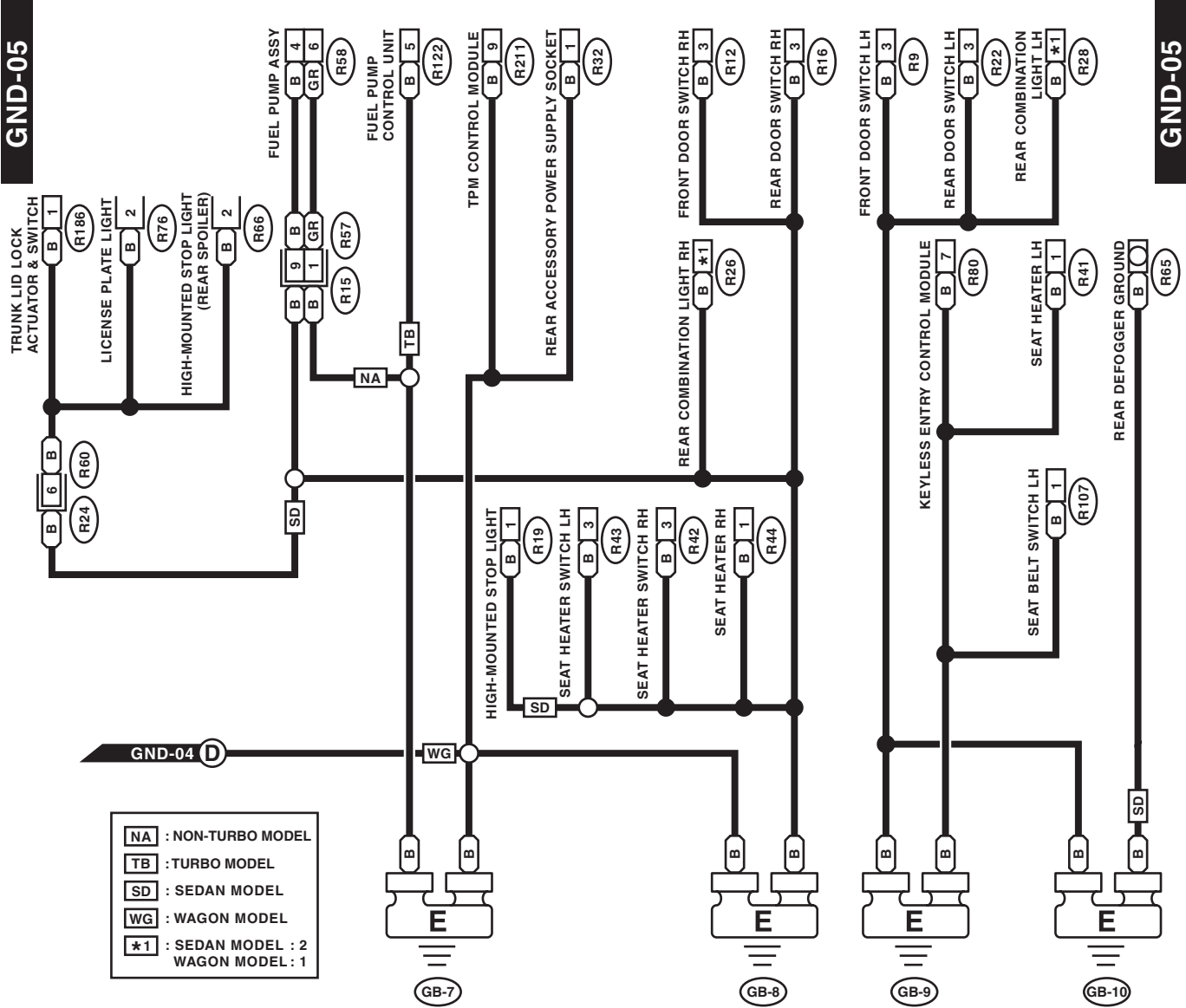

WI-16862

# Ground Circuit

WIRING SYSTEM

Brought to you by *Wiring Studios*  
NOT FOR SALE

**GND-06**

**GND-06**

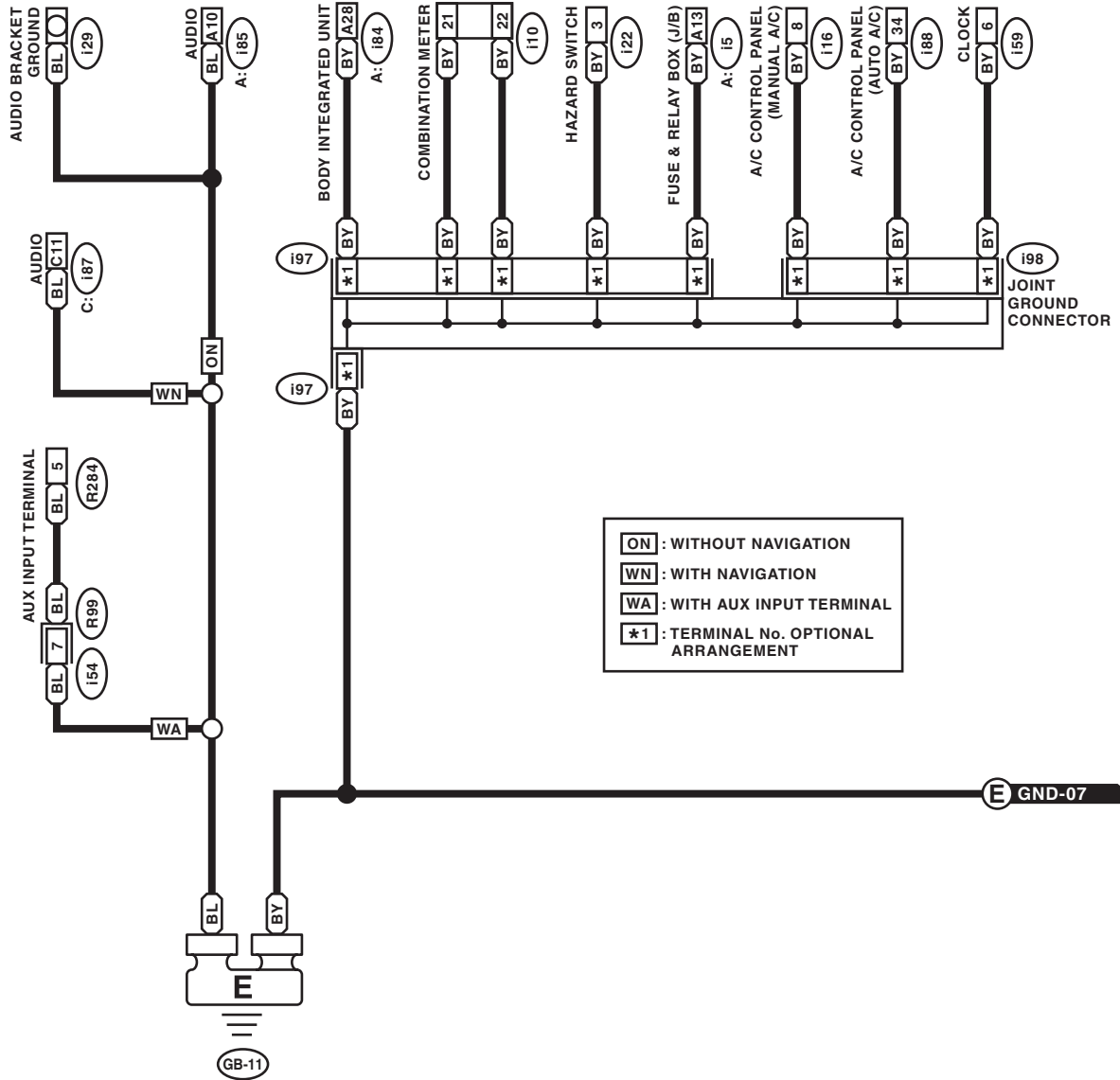

**E GND-07**

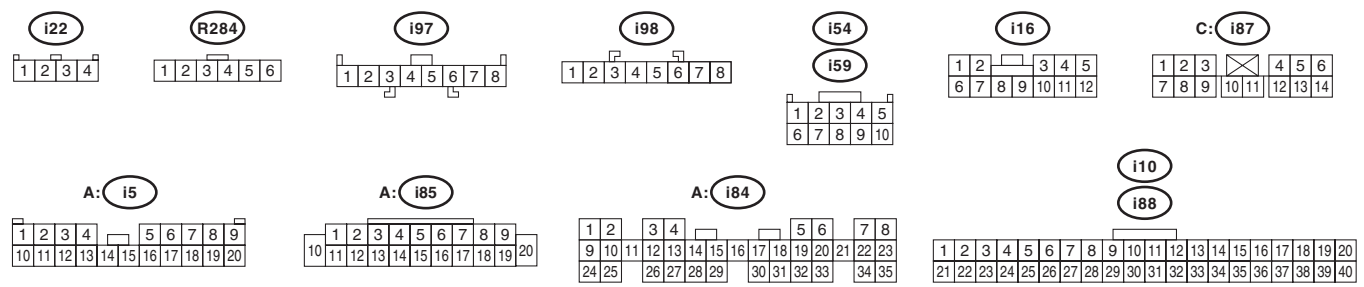

WI-16863

# Ground Circuit

Brought to you by Eris Studios  
NOT FOR RESALE

## WIRING SYSTEM

**GND-07**

**GND-07**

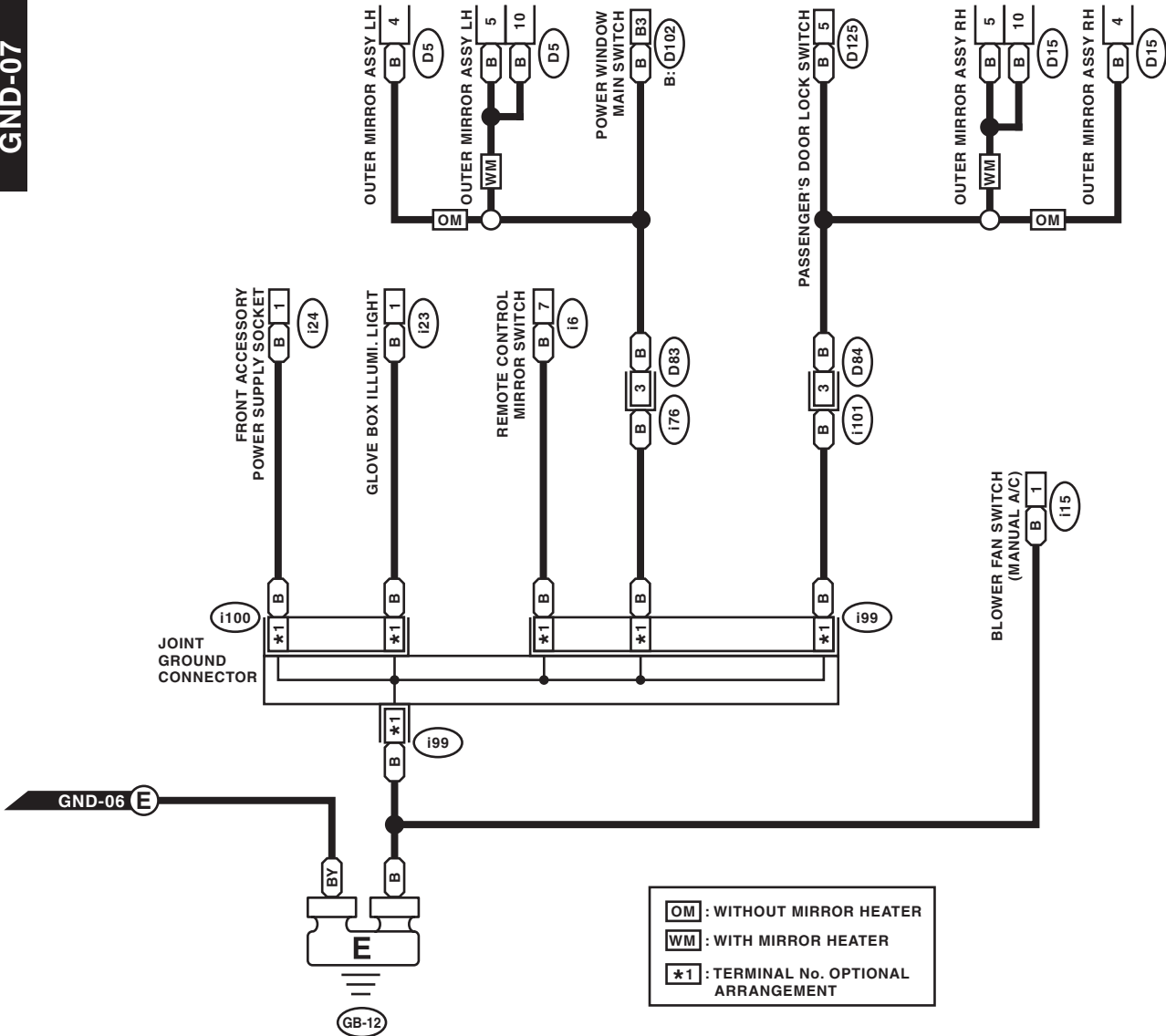

**OM** : WITHOUT MIRROR HEATER  
**WM** : WITH MIRROR HEATER  
**\*1** : TERMINAL No. OPTIONAL ARRANGEMENT

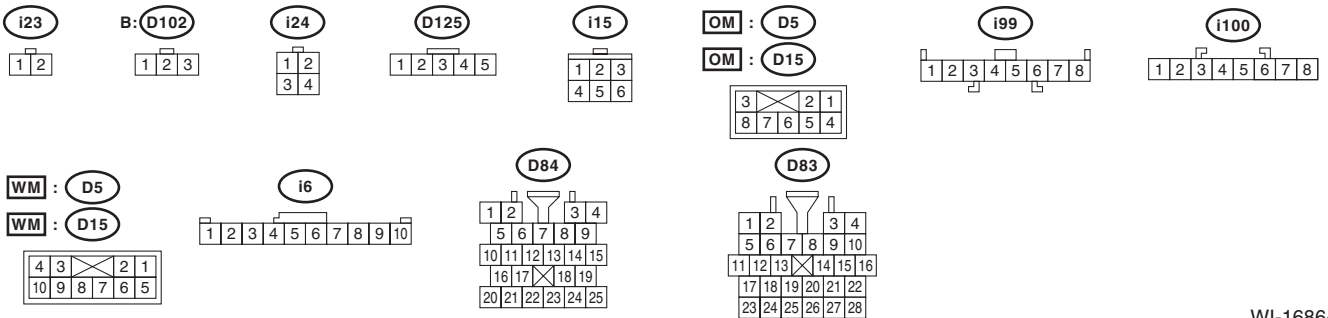

WI-16864

Brought to you by *Chris Studios*  
 NOT FOR SALE

• Engine ground (Non-turbo model)

GND-08

GND-08

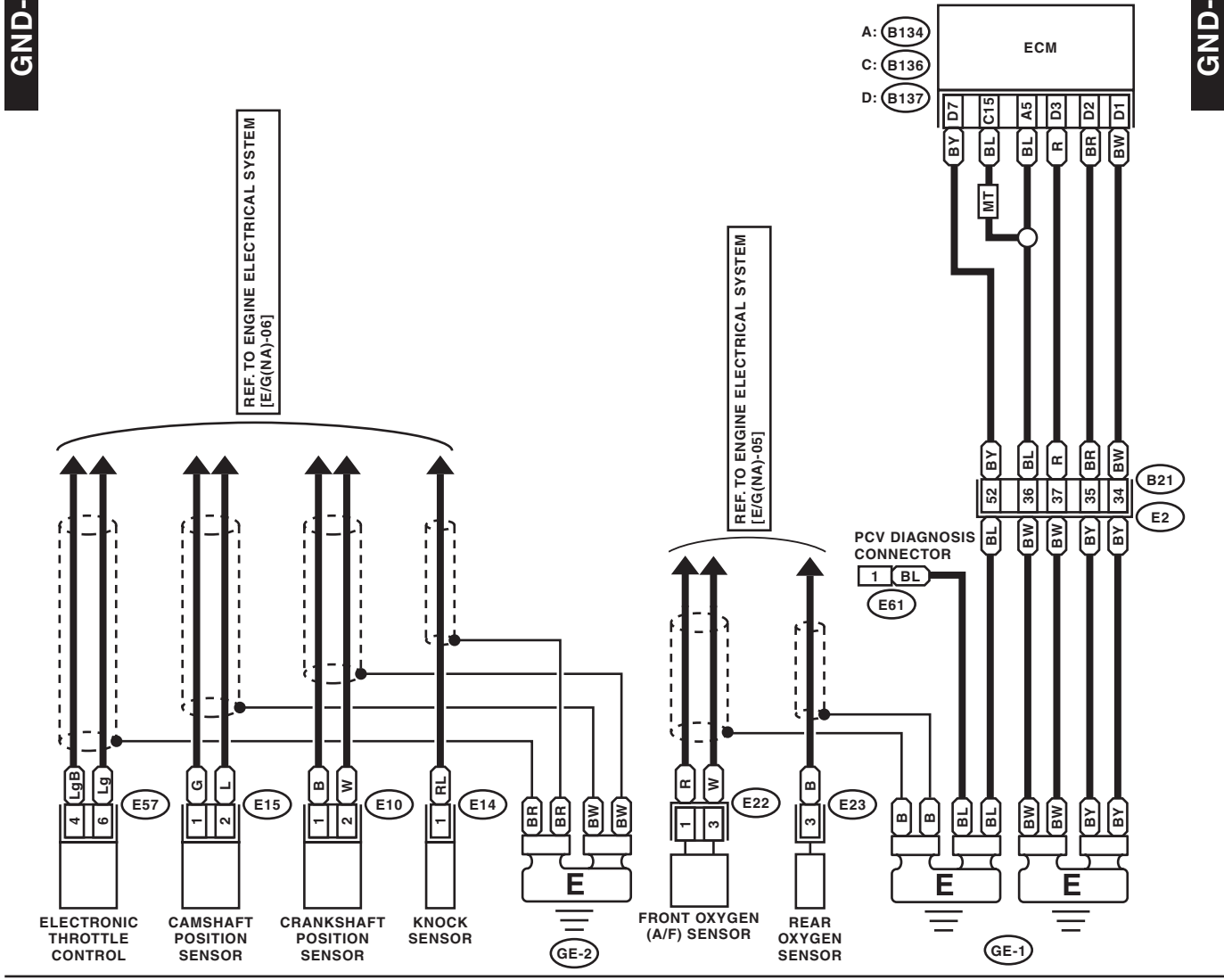

- E10 (LIGHT GRAY)
- E14 (GRAY)
- E23 (DARK GRAY)
- E22 (BLACK)
- E57 (BLACK)
- E15 (BLACK)
- E61 (DARK GRAY)

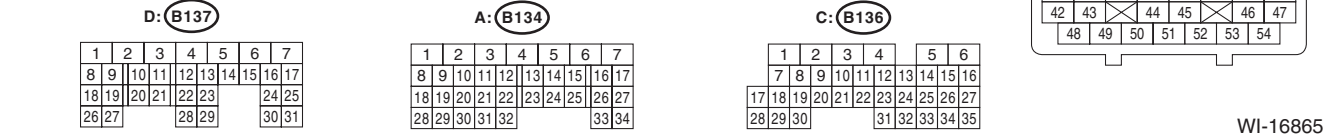

WI-16865

# Ground Circuit

Brought to you by Eris Studios  
NOT FOR RESALE

## WIRING SYSTEM

### • Engine ground (Turbo model)

GND-09

GND-09

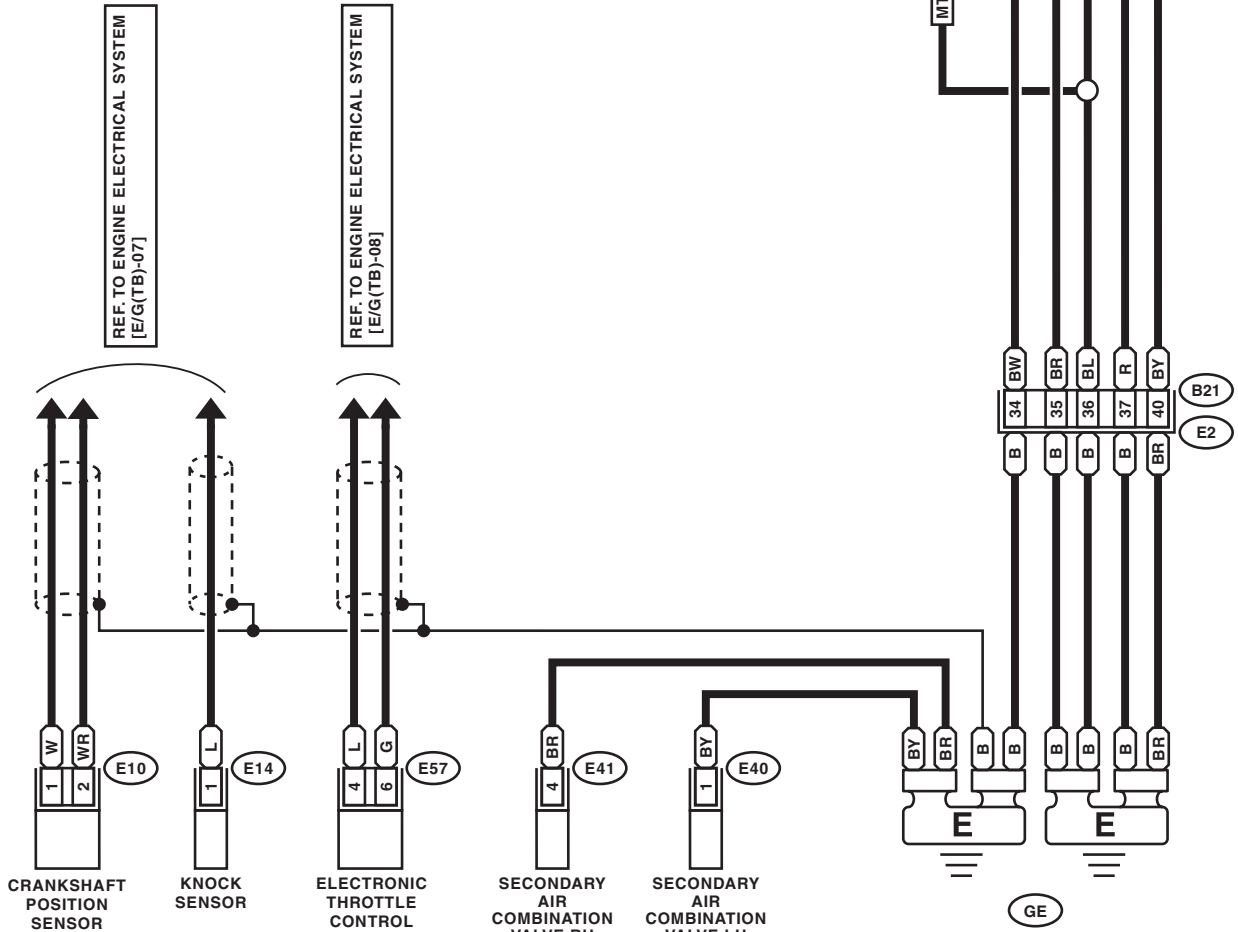

E10 (LIGHT GRAY)

E41 (BLACK)

E57 (BLACK)

D: B137

B21

E14 (LIGHT GRAY)

1	2	3
4	5	6

1	2	3	4	5	6
---	---	---	---	---	---

1	2	3	4	5	6	7			
8	9	10	11	12	13	14	15	16	17
18	19	20	21	22	23	24	25	26	27
28	29	30	31	32	33	34	35		

1	2	3	4	5	6	7	8	9	10	11			
12	13	14	15	16	17	18	19	20	21	22			
23	24	25	26	27	28	29	30	31	32	33			
34	35	36	37	38	39	40	41	42	43	44	45	46	47
48	49	50	51	52	53	54							

E40 (BLACK)

1	2
---	---

A: B134

1	2	3	4	5	6	7			
8	9	10	11	12	13	14	15	16	17
18	19	20	21	22	23	24	25	26	27
28	29	30	31	32	33	34			

C: B136

1	2	3	4	5	6					
7	8	9	10	11	12	13	14	15	16	
17	18	19	20	21	22	23	24	25	26	27
28	29	30	31	32	33	34	35			

WI-16866

# Ground Circuit

WIRING SYSTEM

Brought to you by *Chris Studios*  
 NOT FOR SALE

## • AT transmission ground

GND-10

GND-10

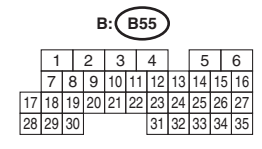
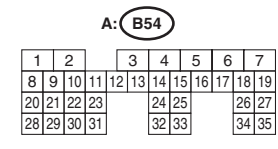
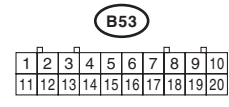
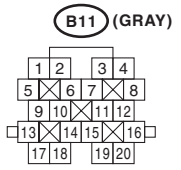
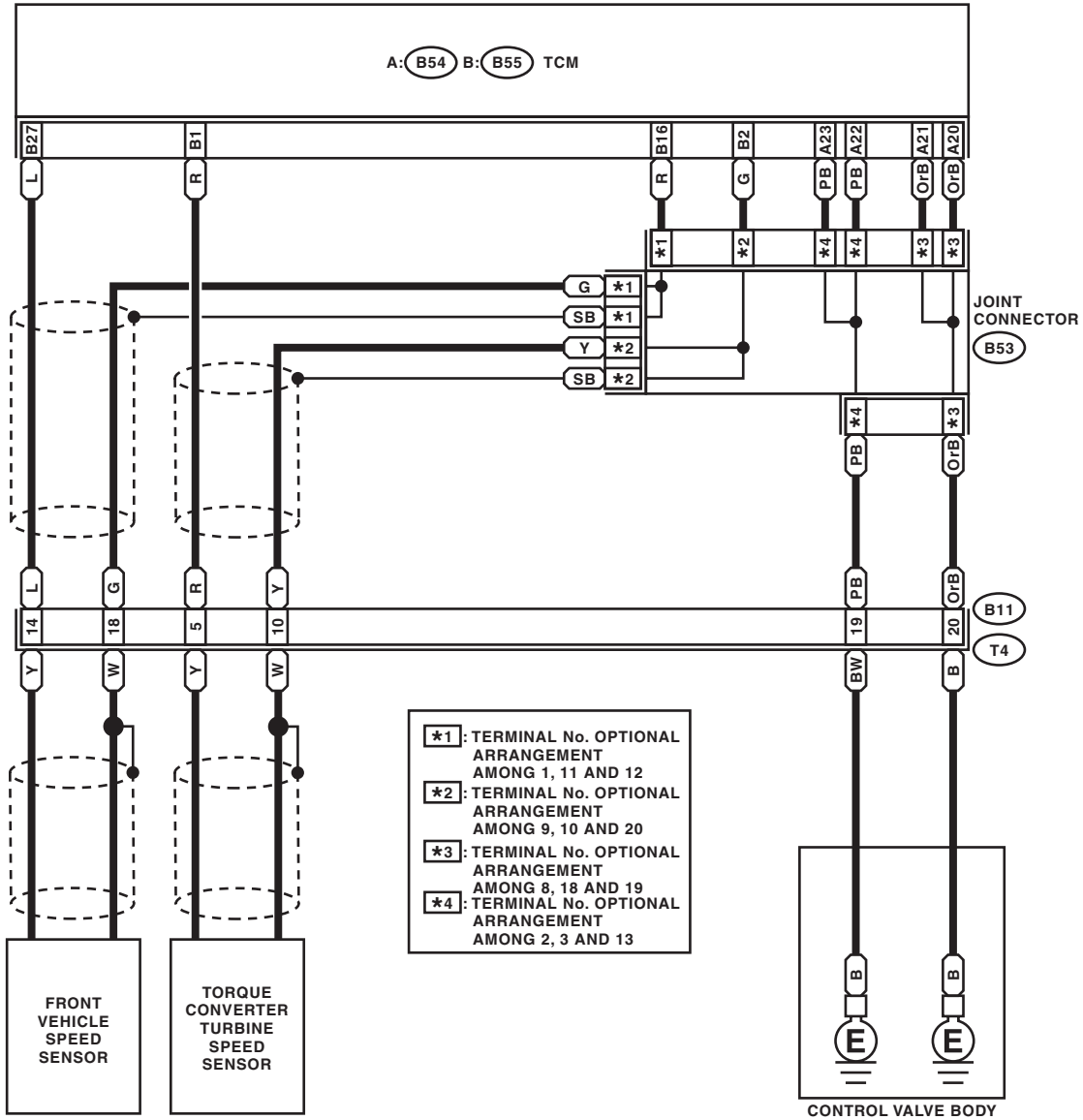

WI-16867

# Ground Circuit

Brought to you by Eris Studios  
NOT FOR RESALE

## WIRING SYSTEM

### 2. TRANSMISSION SERIAL NO. 4078113 OR LATER

- Body ground

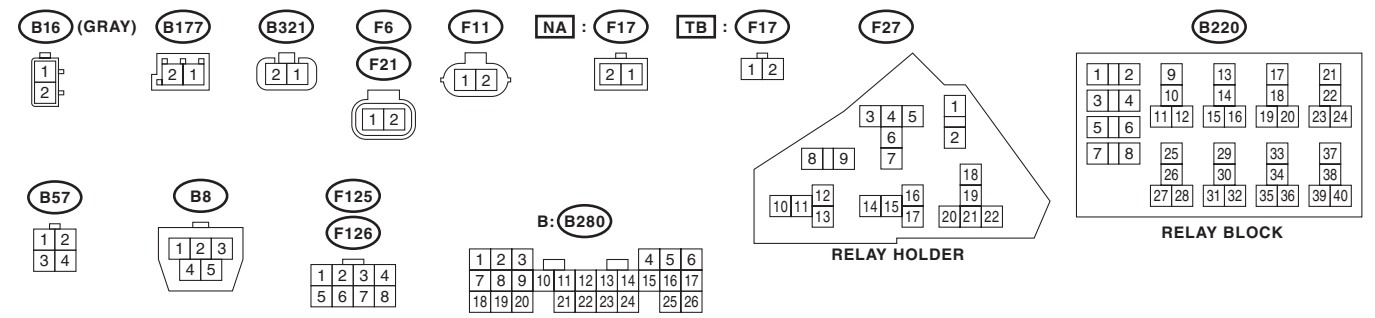
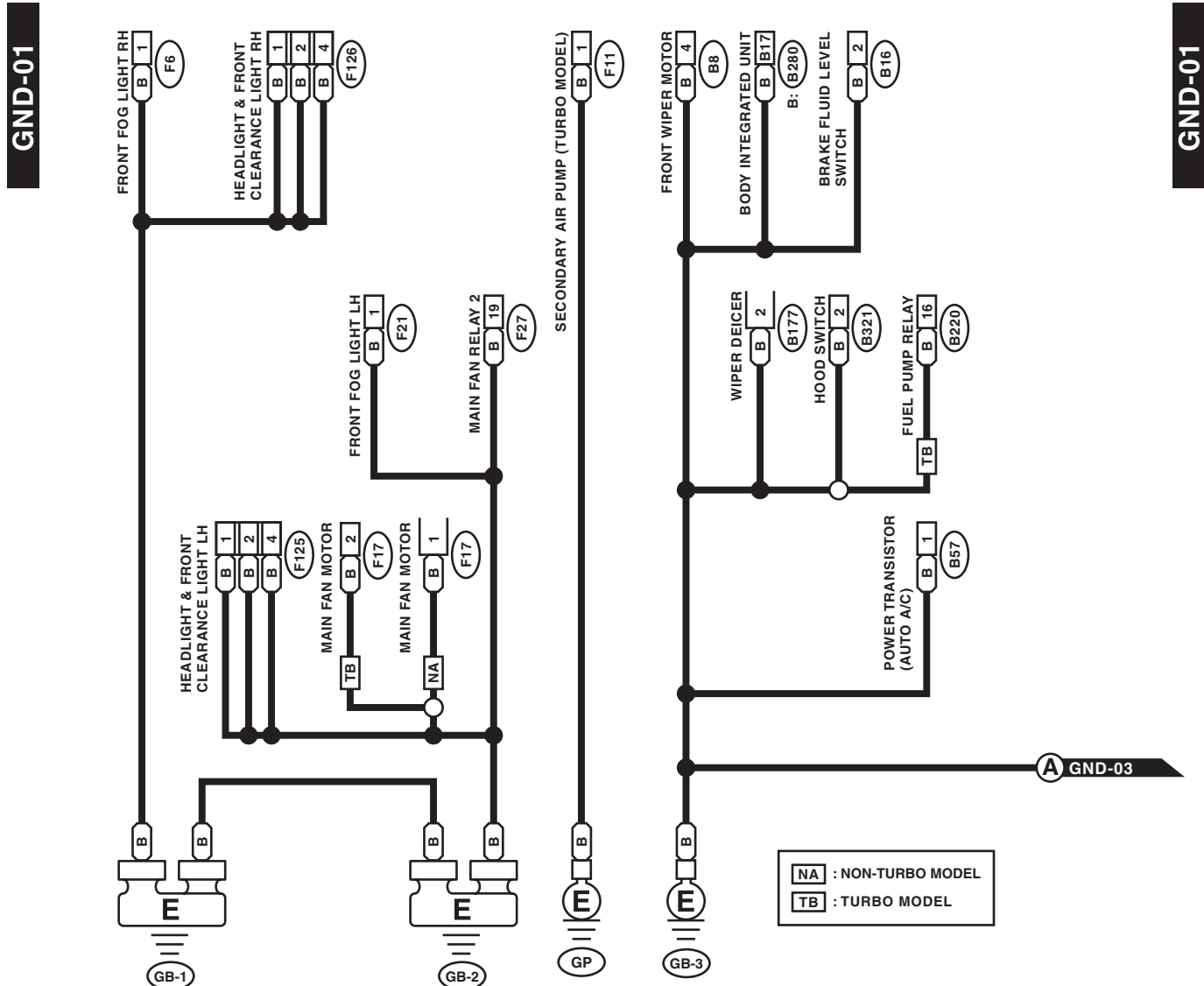

WI-16858



# Ground Circuit

WIRING SYSTEM

Brought to you by *Chris Studios*  
NOT FOR SALE

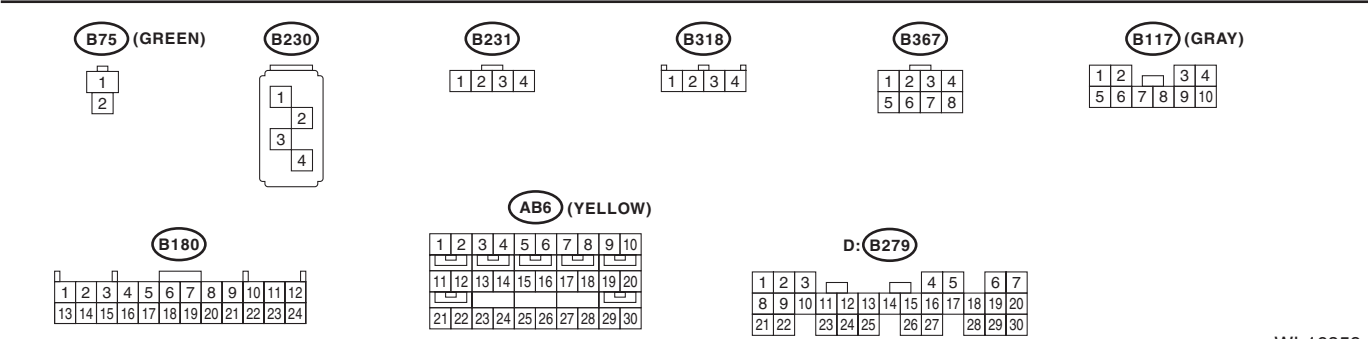
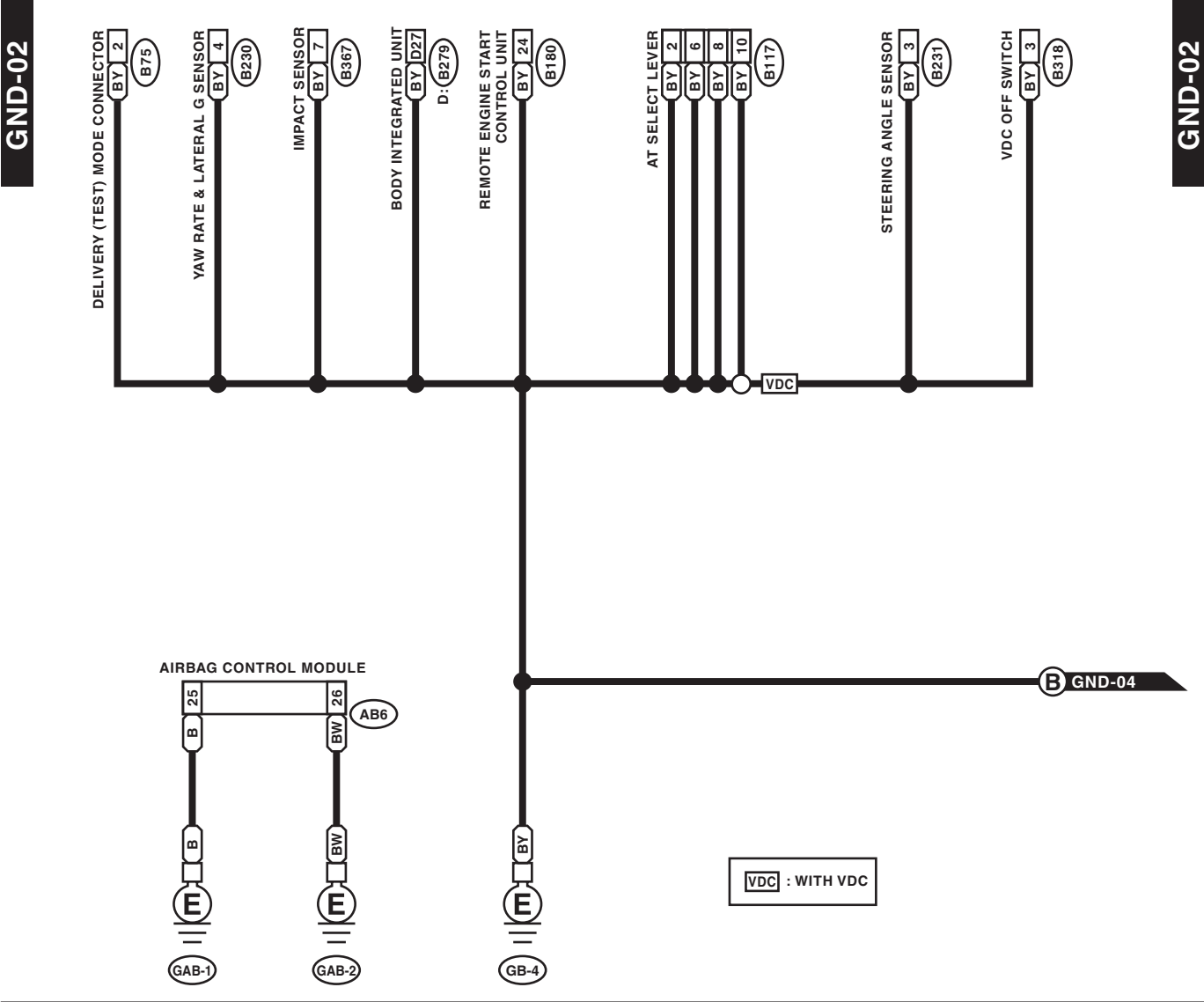

WI-16859

# Ground Circuit

Brought to you by Eris Studios  
NOT FOR RESALE

## WIRING SYSTEM

**GND-03**

**GND-03**

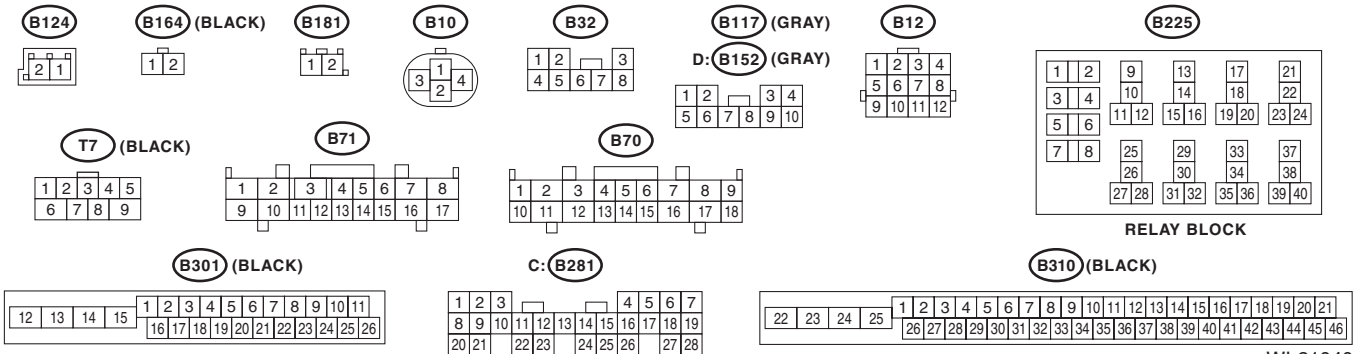
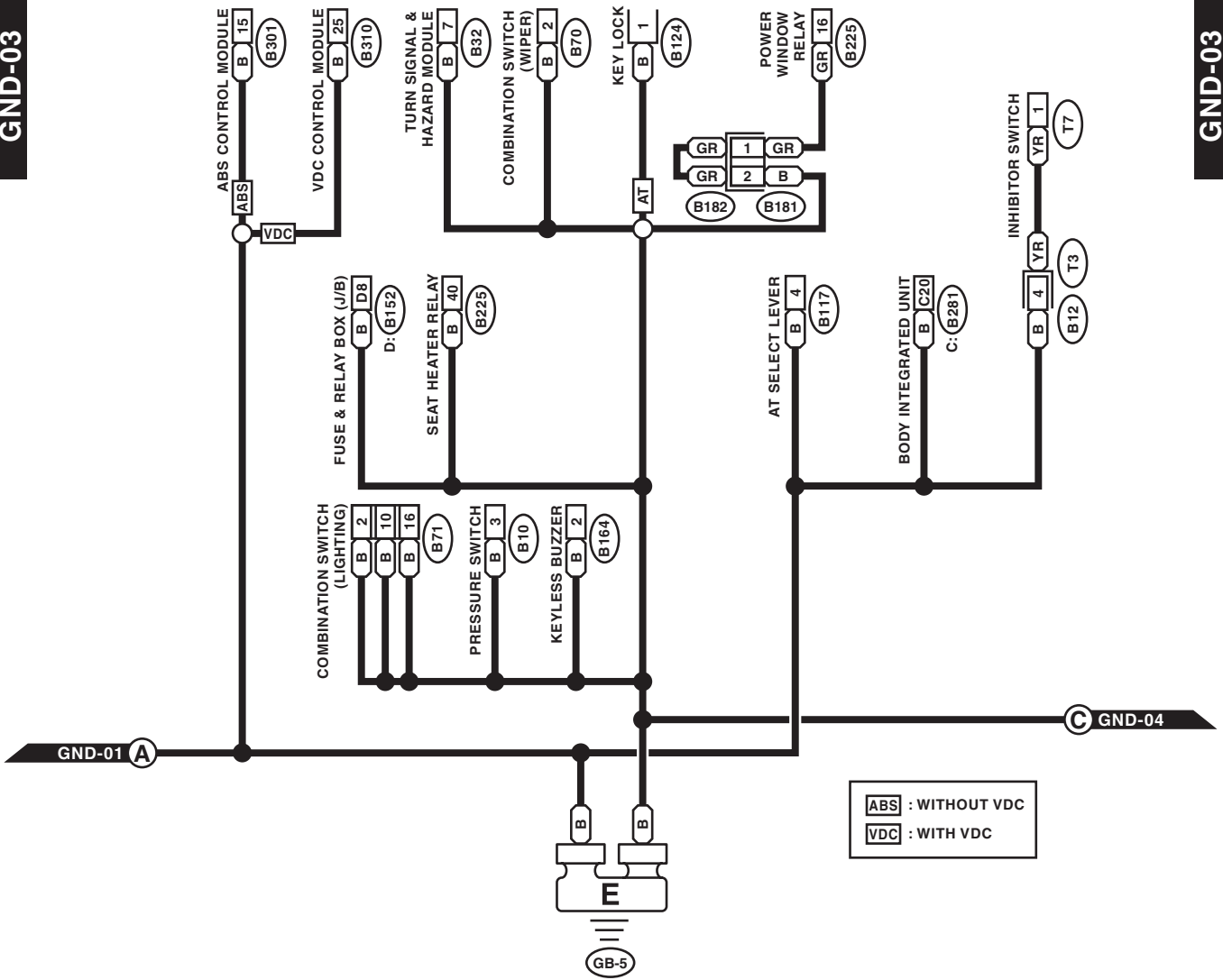

WI-21040

# Ground Circuit

WIRING SYSTEM

Brought to you by *Chris Studios*  
 NOT FOR SALE

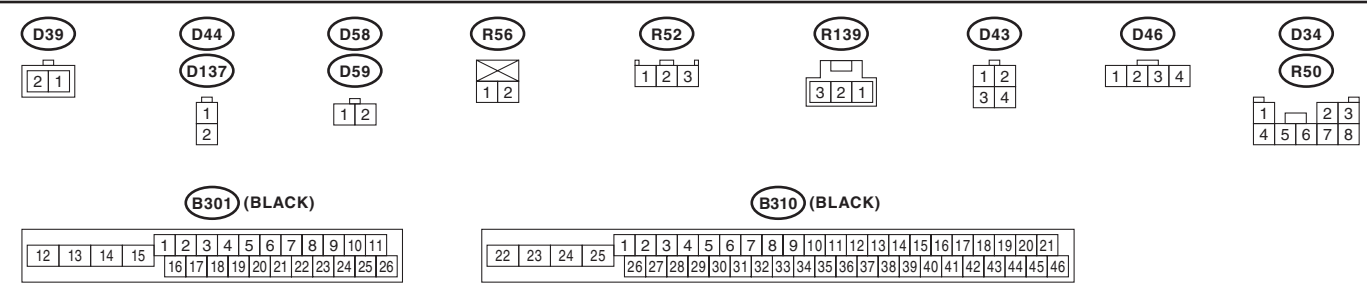
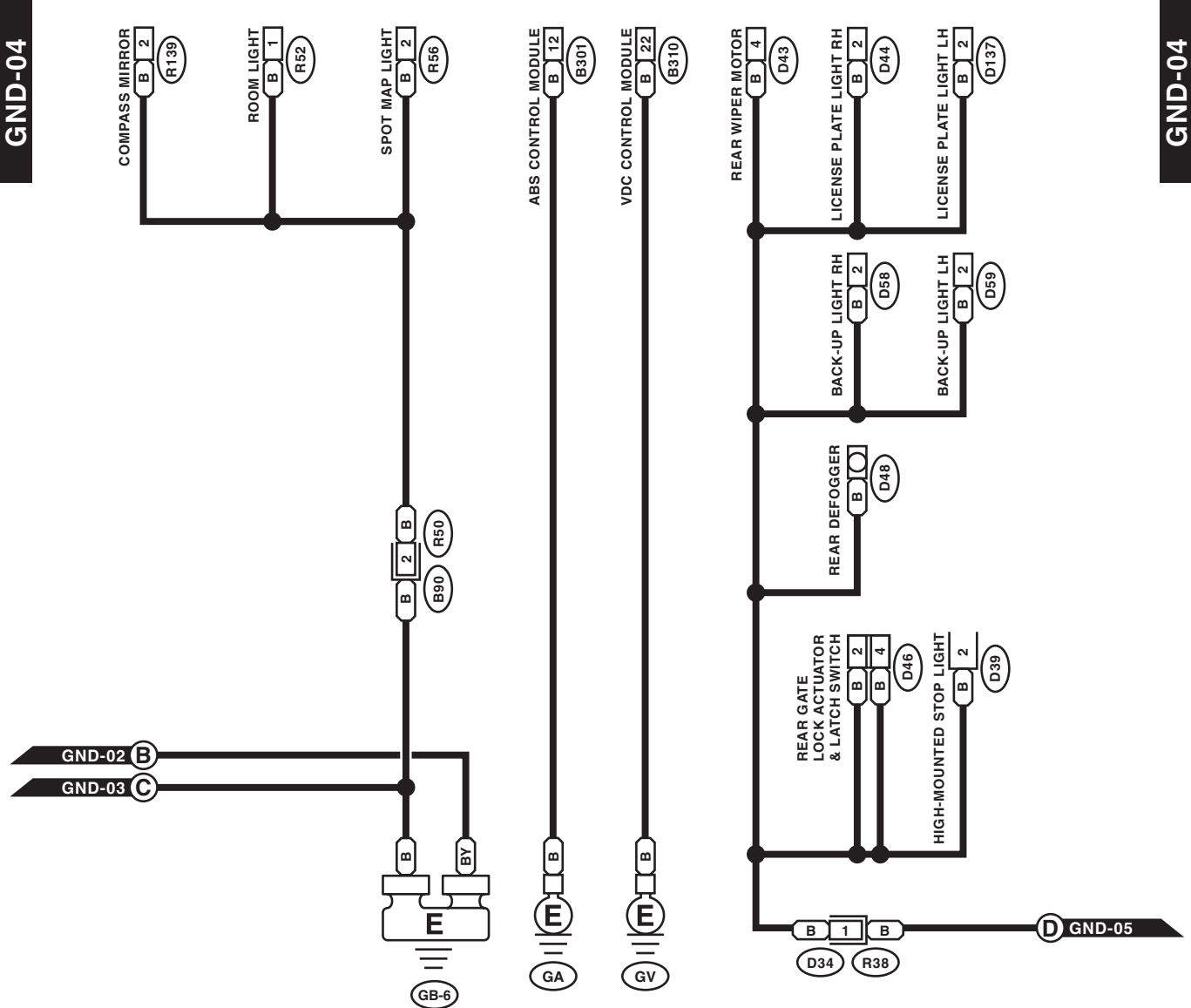

WI-16861

# Ground Circuit

Brought to you by Eris Studios  
NOT FOR RESALE

## WIRING SYSTEM

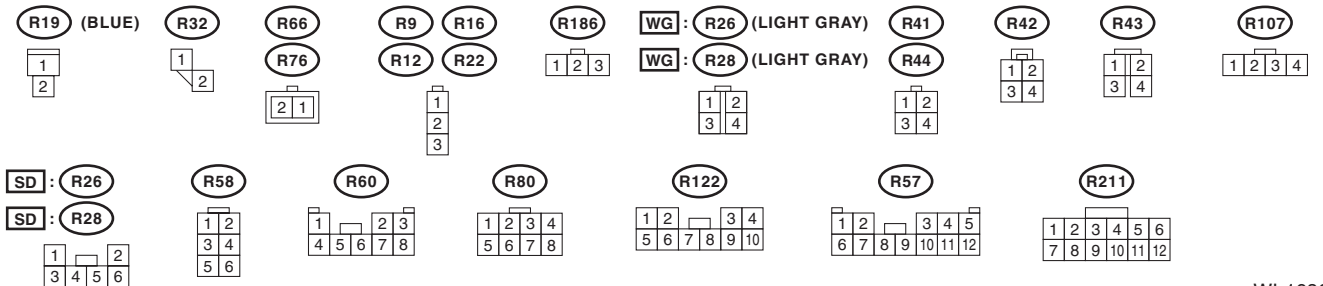
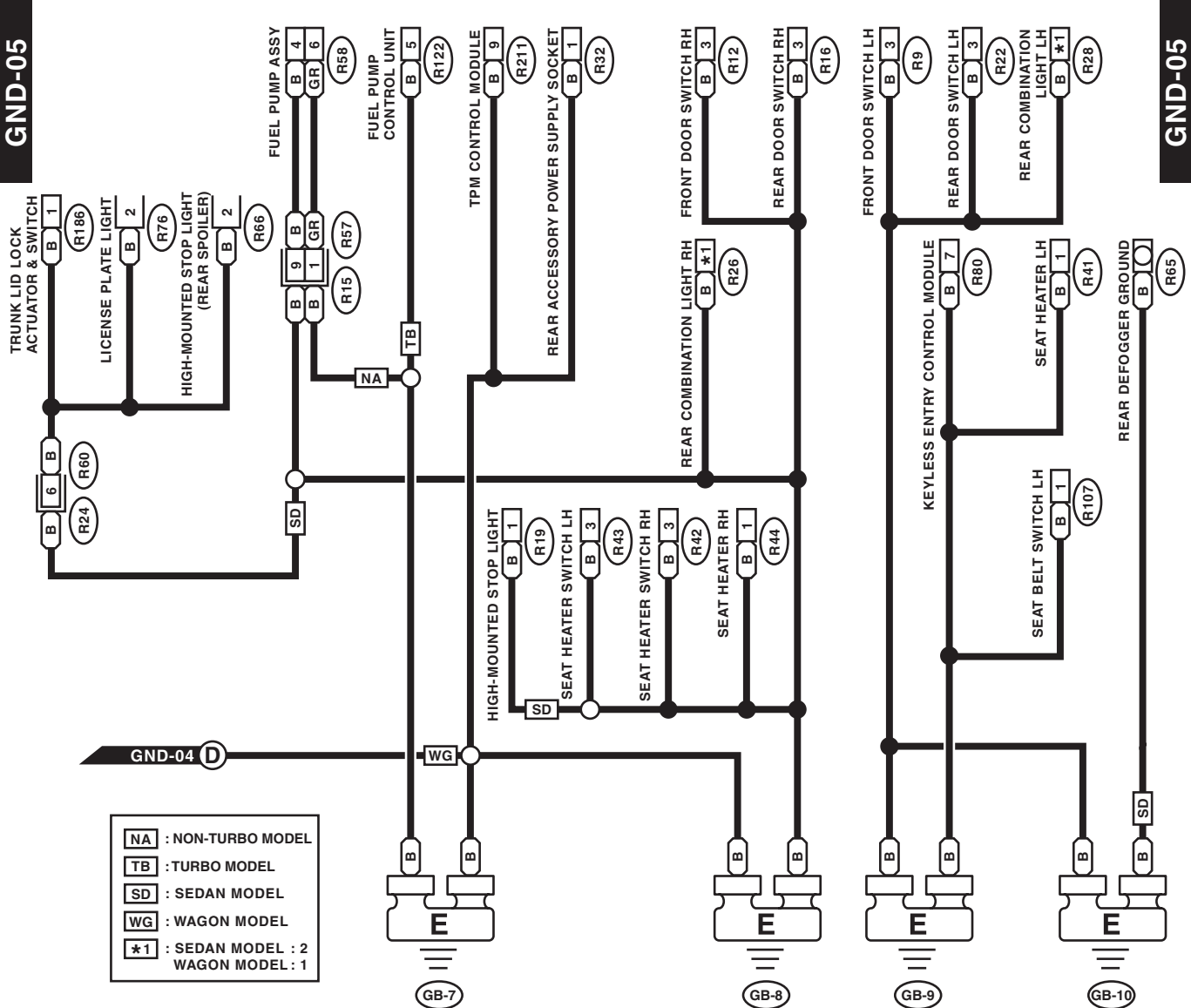

WI-16862

# Ground Circuit

WIRING SYSTEM

Brought to you by *Chris Studios*  
NOT FOR SALE

**GND-06**

**GND-06**

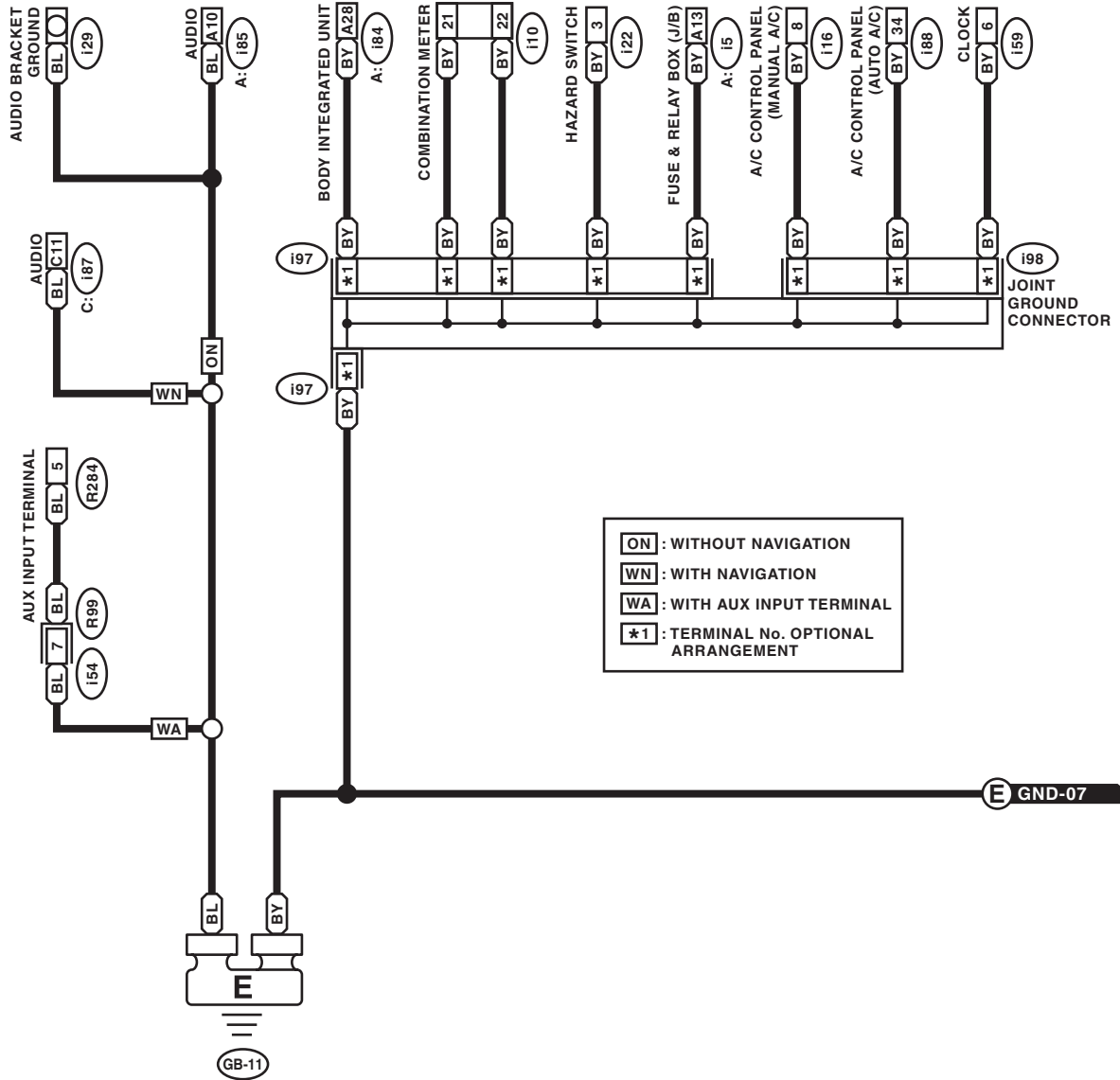

**E GND-07**

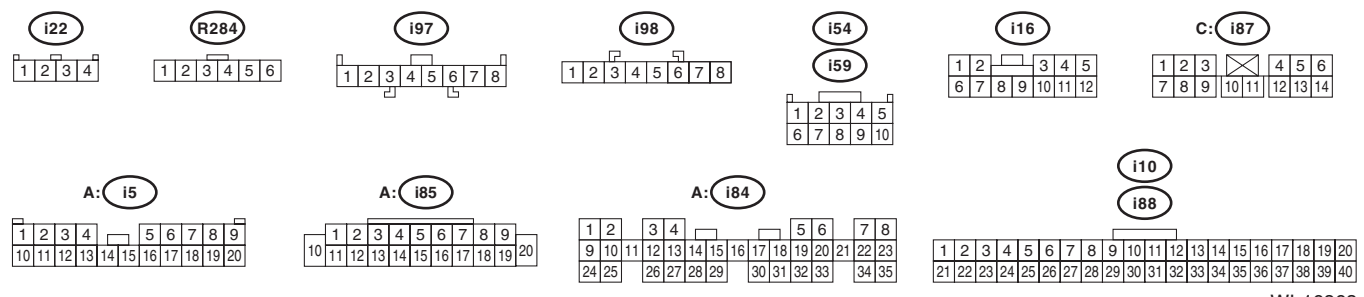

WI-16863

# Ground Circuit

Brought to you by Eris Studios  
NOT FOR RESALE

## WIRING SYSTEM

**GND-07**

**GND-07**

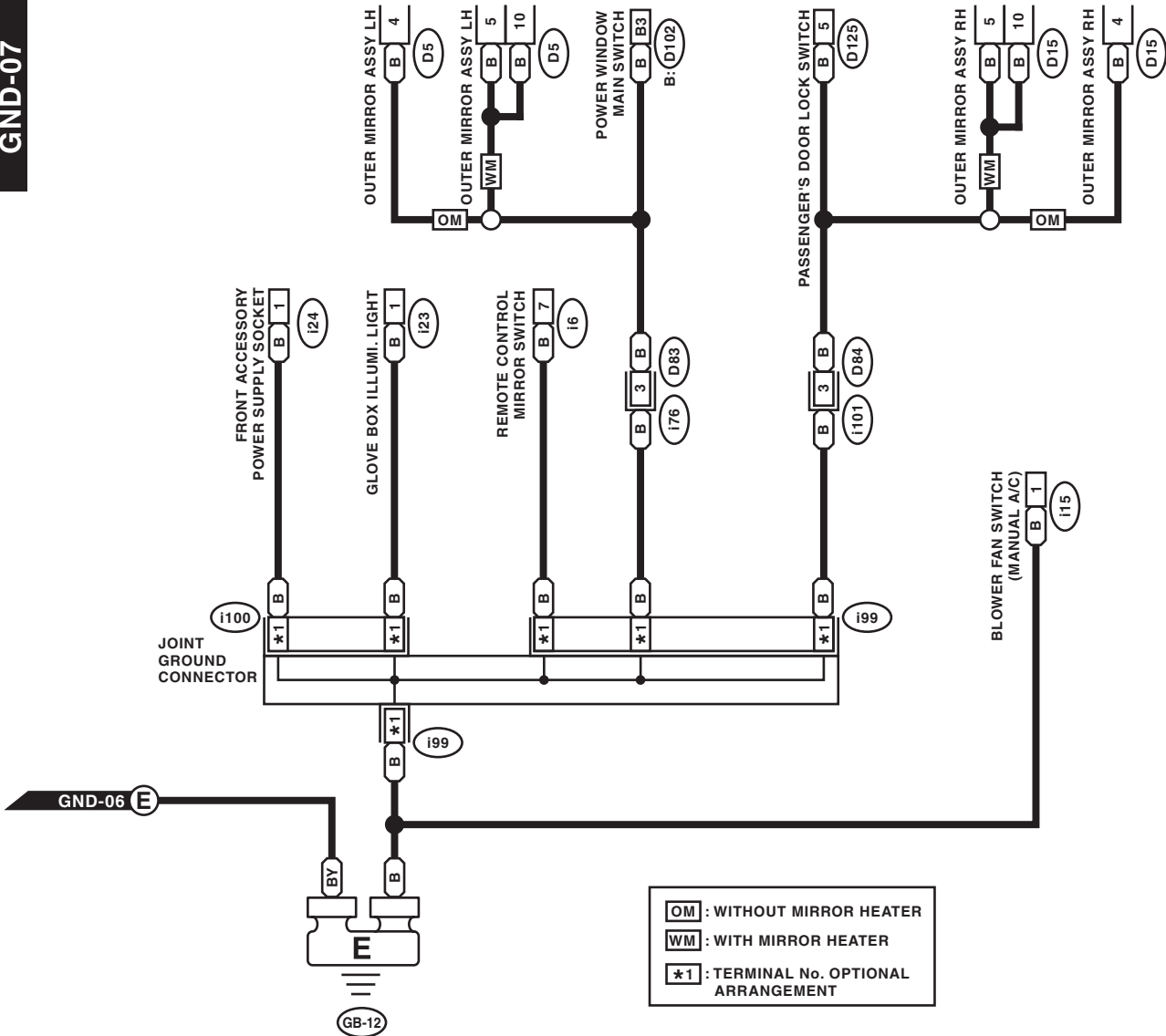

**OM** : WITHOUT MIRROR HEATER  
**WM** : WITH MIRROR HEATER  
**\*1** : TERMINAL No. OPTIONAL ARRANGEMENT

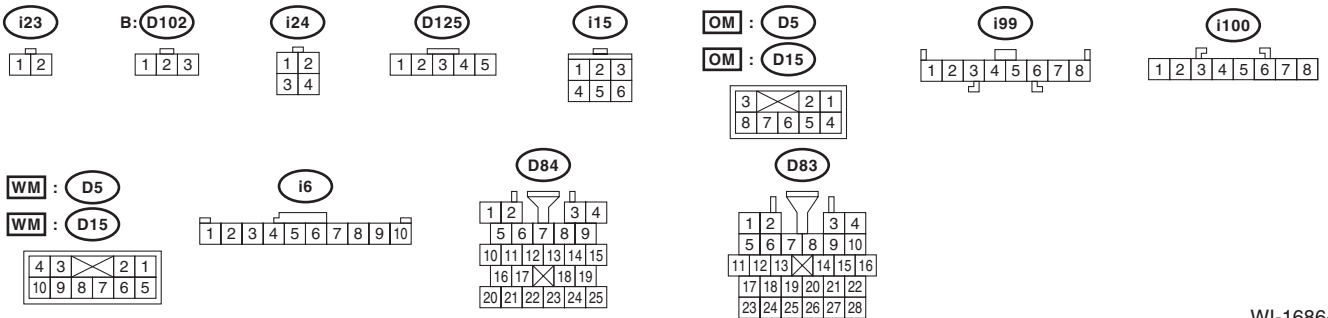

WI-16864

Brought to you by Pro Performance Studios  
 NOT FOR SALE

• Engine ground (Non-turbo model)

GND-08

GND-08

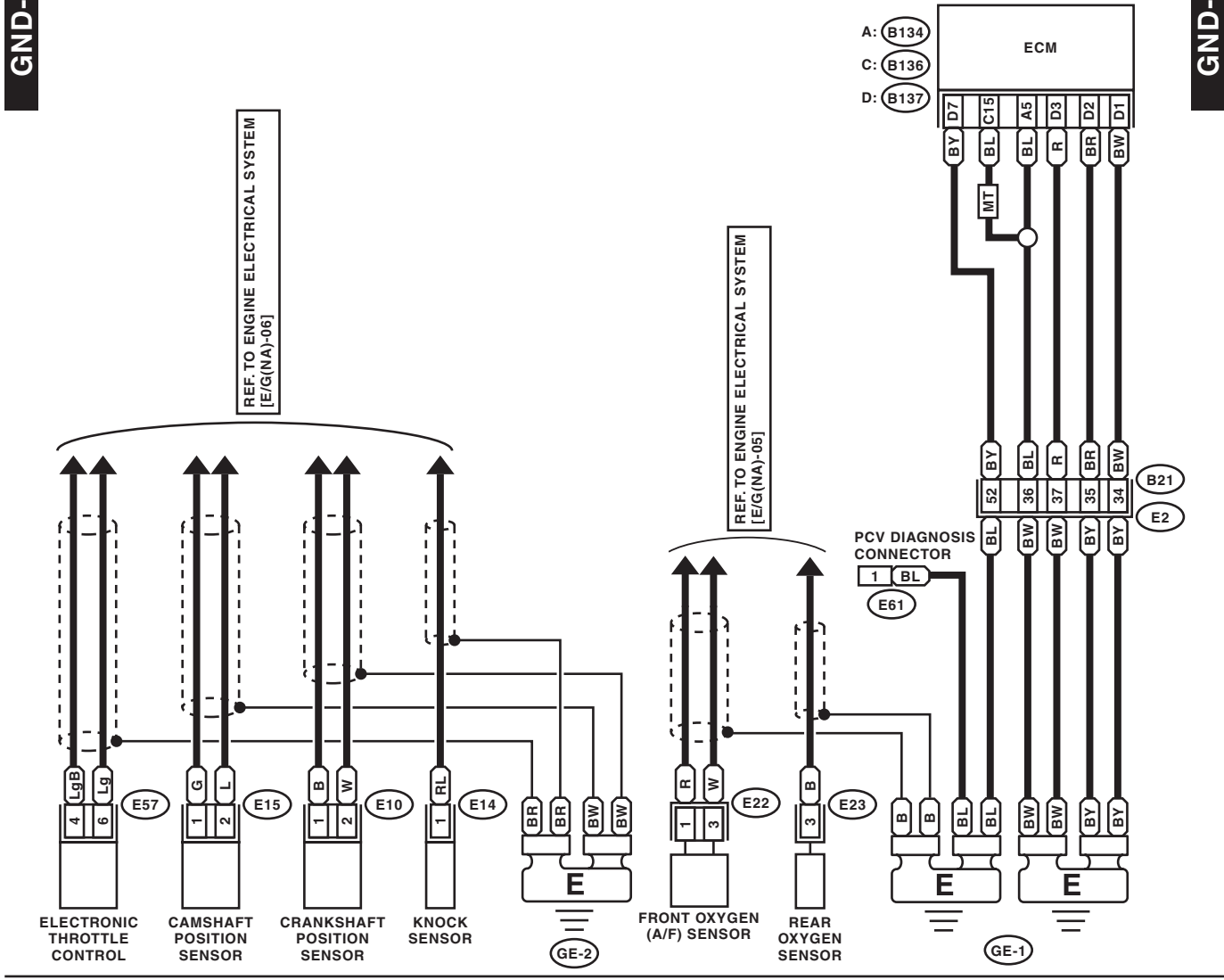

**E10 (LIGHT GRAY)**    **E14 (GRAY)**    **E23 (DARK GRAY)**    **E22 (BLACK)**    **E57 (BLACK)**

**E15 (BLACK)**    **E61 (DARK GRAY)**

**D: B137**    **A: B134**    **C: B136**    **B21**

1	2
3	4

1	2	3	4	5	6
7	8	9	10	11	12
13	14	15	16	17	18
19	20	21	22	23	24
25	26	27	28	29	30
31	32	33	34	35	36

1	2	3	4	5	6
7	8	9	10	11	12
13	14	15	16	17	18
19	20	21	22	23	24
25	26	27	28	29	30
31	32	33	34	35	36

1	2	3	4	5	6	7	8	9	10	11	12	13	14	15	16	17	18	19	20	21	22	23	24	25	26	27	28	29	30	31	32	33	34	35	36	37	38	39	40	41	42	43	44	45	46	47	48	49	50	51	52	53	54
---	---	---	---	---	---	---	---	---	----	----	----	----	----	----	----	----	----	----	----	----	----	----	----	----	----	----	----	----	----	----	----	----	----	----	----	----	----	----	----	----	----	----	----	----	----	----	----	----	----	----	----	----	----

WI-16865

# Ground Circuit

Brought to you by Eris Studios  
NOT FOR RESALE

## WIRING SYSTEM

### • Engine ground (Turbo model)

GND-09

GND-09

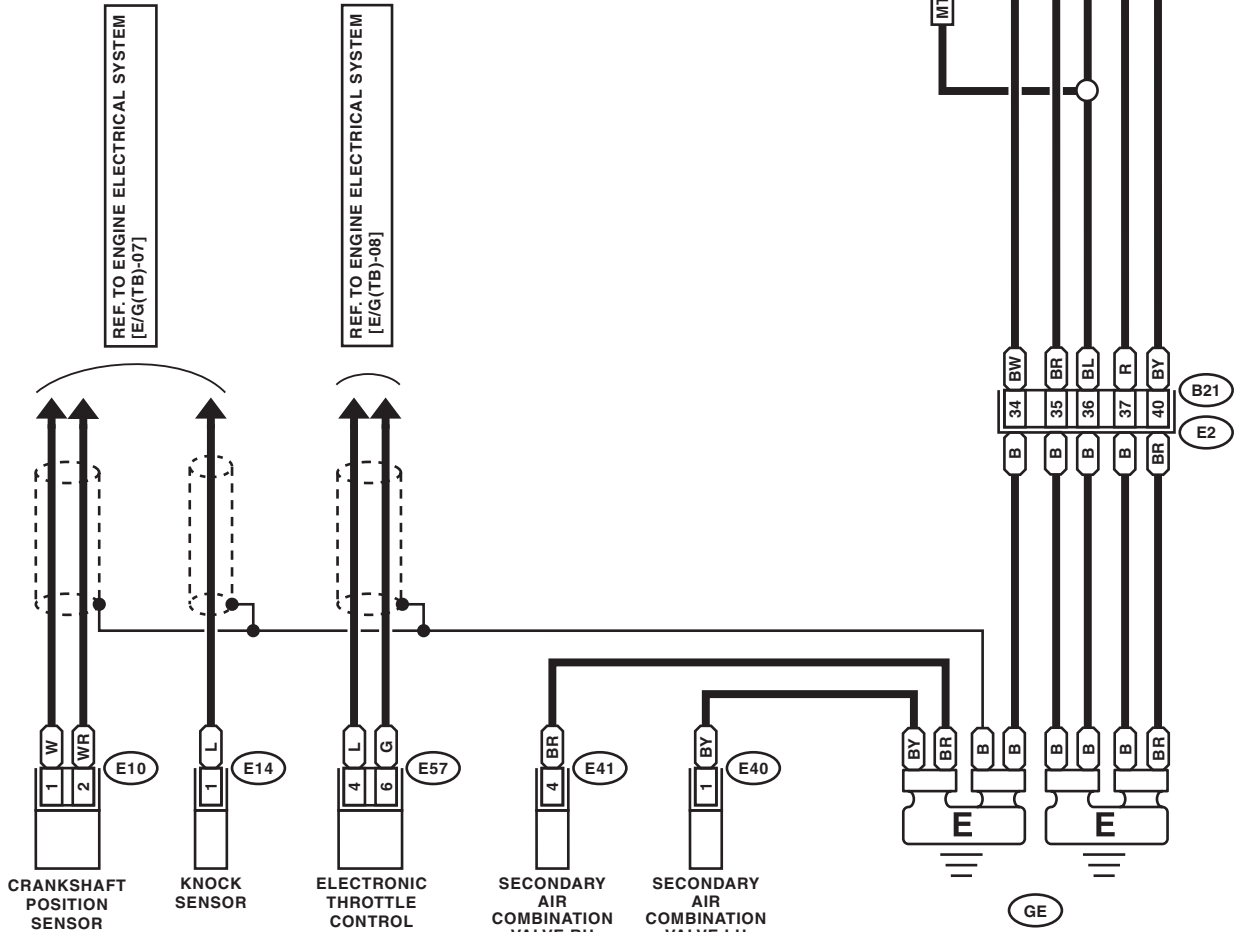

- E10 (LIGHT GRAY)
- E14 (LIGHT GRAY)
- E40 (BLACK)

- E41 (BLACK)

- E57 (BLACK)

- D: B137

- B21

A: B134

1	2	3	4	5	6	7
8	9	10	11	12	13	14
15	16	17	18	19	20	21
22	23	24	25	26	27	28
29	30	31	32	33	34	

C: B136

1	2	3	4	5	6
7	8	9	10	11	12
13	14	15	16	17	18
19	20	21	22	23	24
25	26	27	28	29	30
31	32	33	34	35	

1	2	3	4	5	6	7
8	9	10	11	12	13	14
15	16	17	18	19	20	21
22	23	24	25	26	27	28
29	30	31	32	33	34	35

1	2	3	4	5	6	7	8	9	10	11
12	13	14	15	16	17	18	19	20	21	22
23	24	25	26	27	28	29	30	31	32	33
34	35	36	37	38	39	40	41	42	43	44
45	46	47	48	49	50	51	52	53	54	

WI-16866



# Ground Circuit

WIRING SYSTEM

Brought to you by *Chris Studios*  
 NOT FOR SALE

## • AT transmission ground

GND-10

GND-10

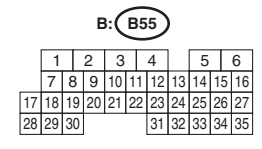
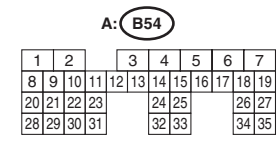
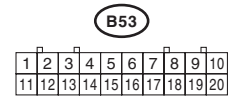
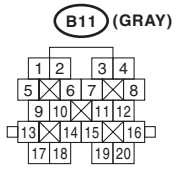
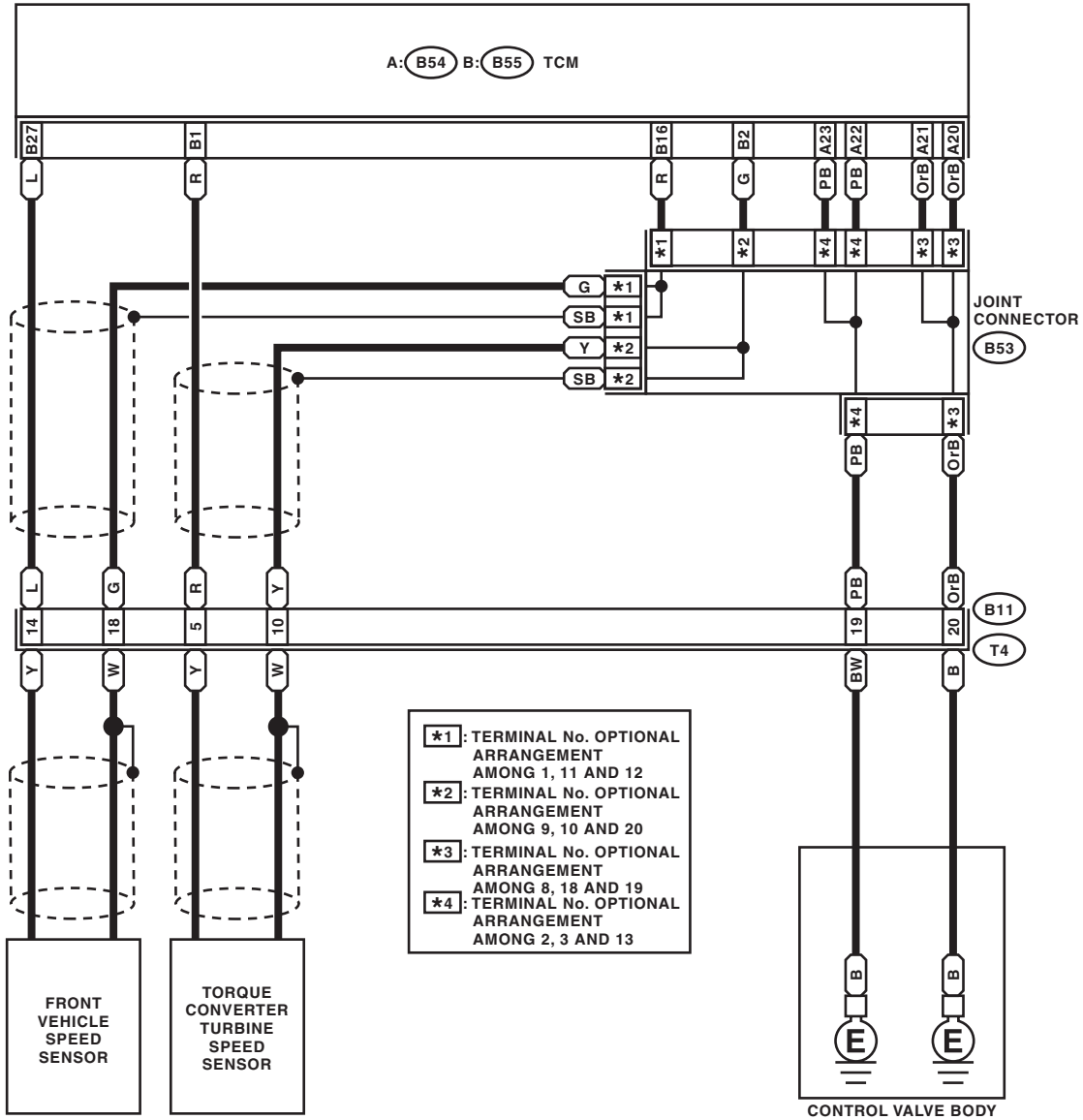

WI-16867

# Engine Electrical System

Brought to you by Eris Studios  
NOT FOR SALE

## WIRING SYSTEM

### 5. Engine Electrical System

#### A: WIRING DIAGRAM

##### 1. NON-TURBO MODEL

- Transmission serial No. 4078112 or earlier

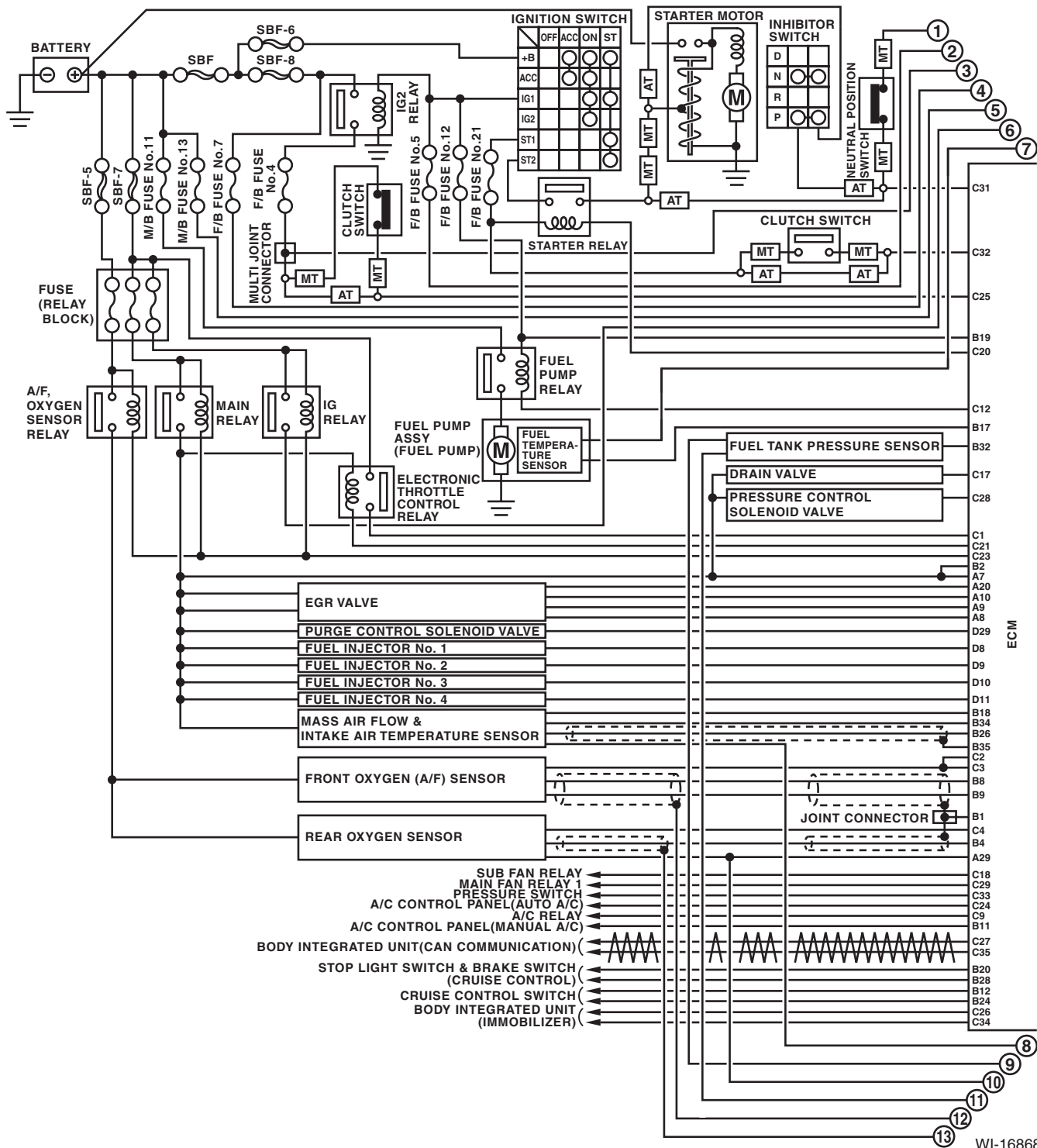

Brought to you by *Chris Studios*  
NOT FOR SALE

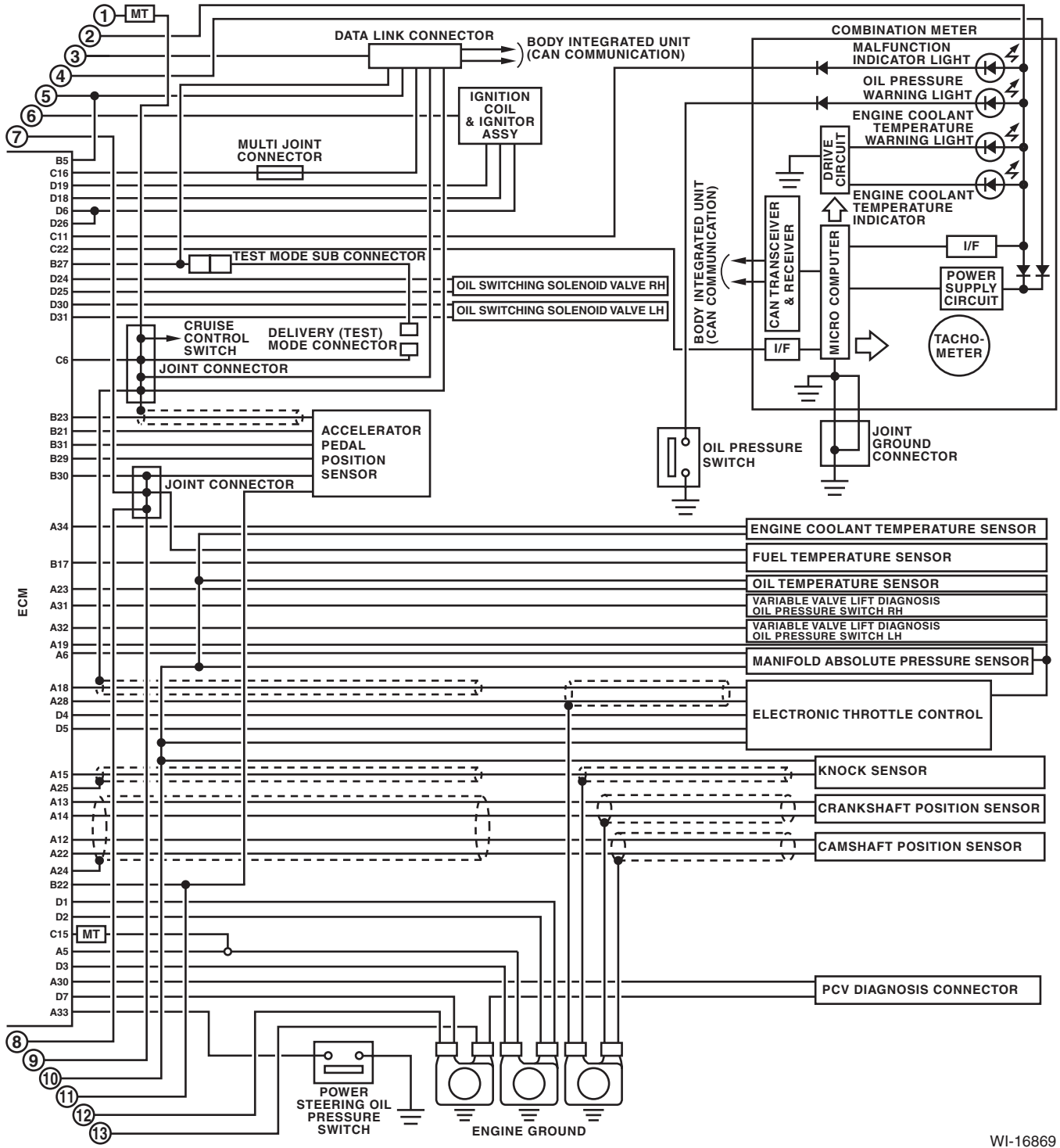

WI-16869

# Engine Electrical System

Brought to you by Eris Studios  
NOT FOR RESALE

## WIRING SYSTEM

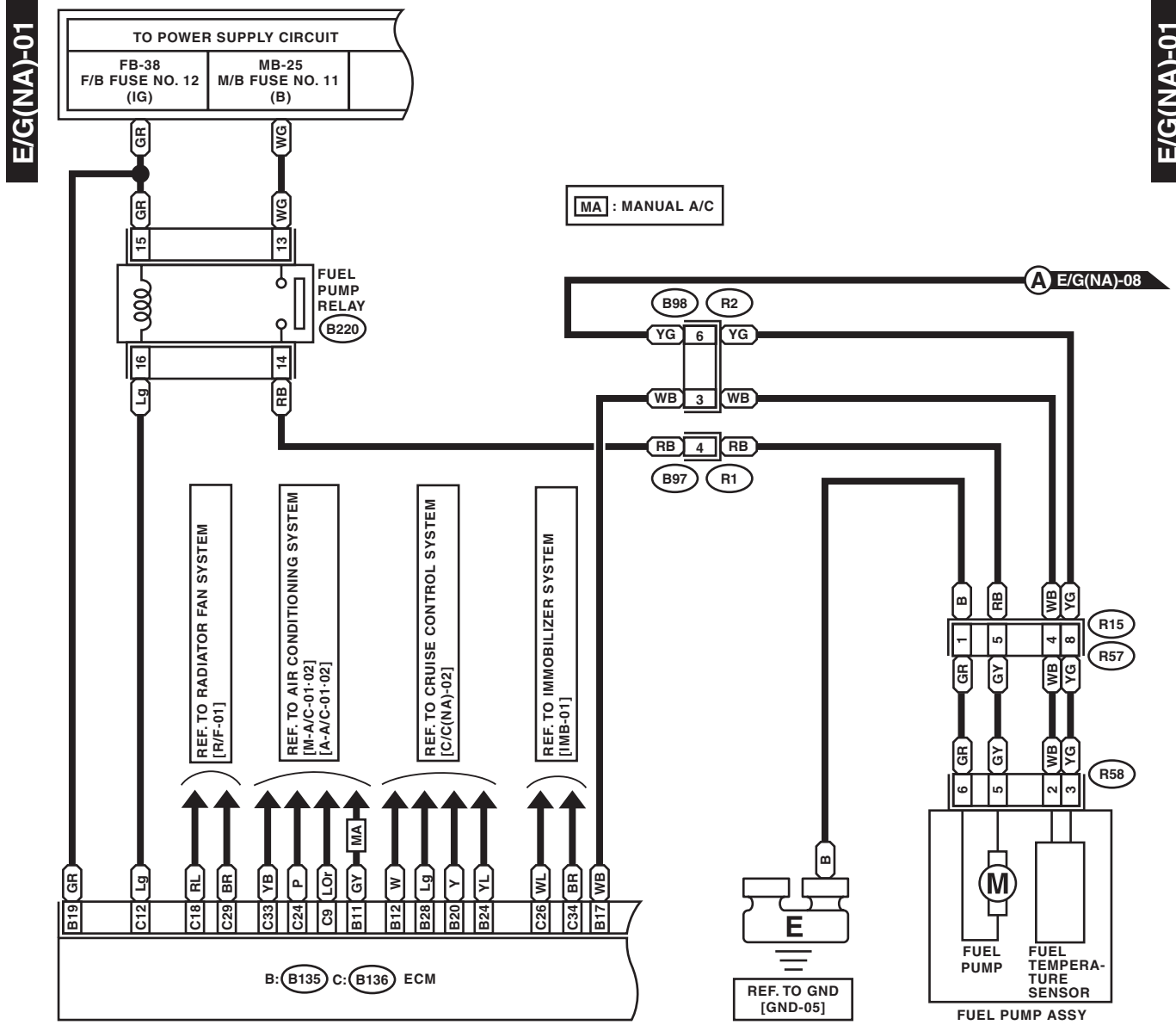

R58

1	2
3	4
5	6

R57 B97

1	2	3	4	5		
6	7	8	9	10	11	12

B98

1	2	3	4	5	6	7	8	9		
10	11	12	13	14	15	16	17	18	19	20

B: B135

1	2	3	4	5	6	7					
8	9	10	11	12	13	14	15	16	17	18	19
20	21	22	23	24	25	26	27	28	29	30	31
				32	33	34	35				

C: B136

1	2	3	4	5	6					
7	8	9	10	11	12	13	14	15	16	
17	18	19	20	21	22	23	24	25	26	27
28	29	30		31	32	33	34	35		

B220

1	2	9	13	17	21				
3	4	10	14	18	22				
5	6	11	15	19	20	23	24		
7	8	25	29	33	37				
		26	30	34	38				
		27	28	31	32	35	36	39	40

RELAY BLOCK

WI-16870

# Engine Electrical System

WIRING SYSTEM

Brought to you by *Chris Studios*  
NOT FOR SALE

E/G(NA)-02

E/G(NA)-02

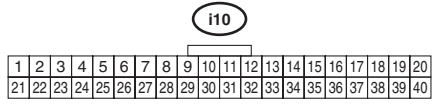
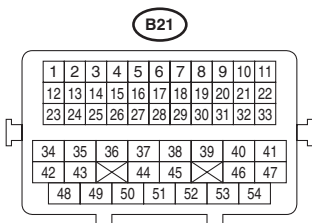
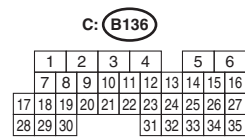
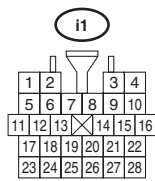
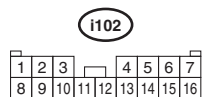
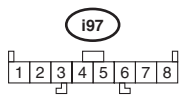
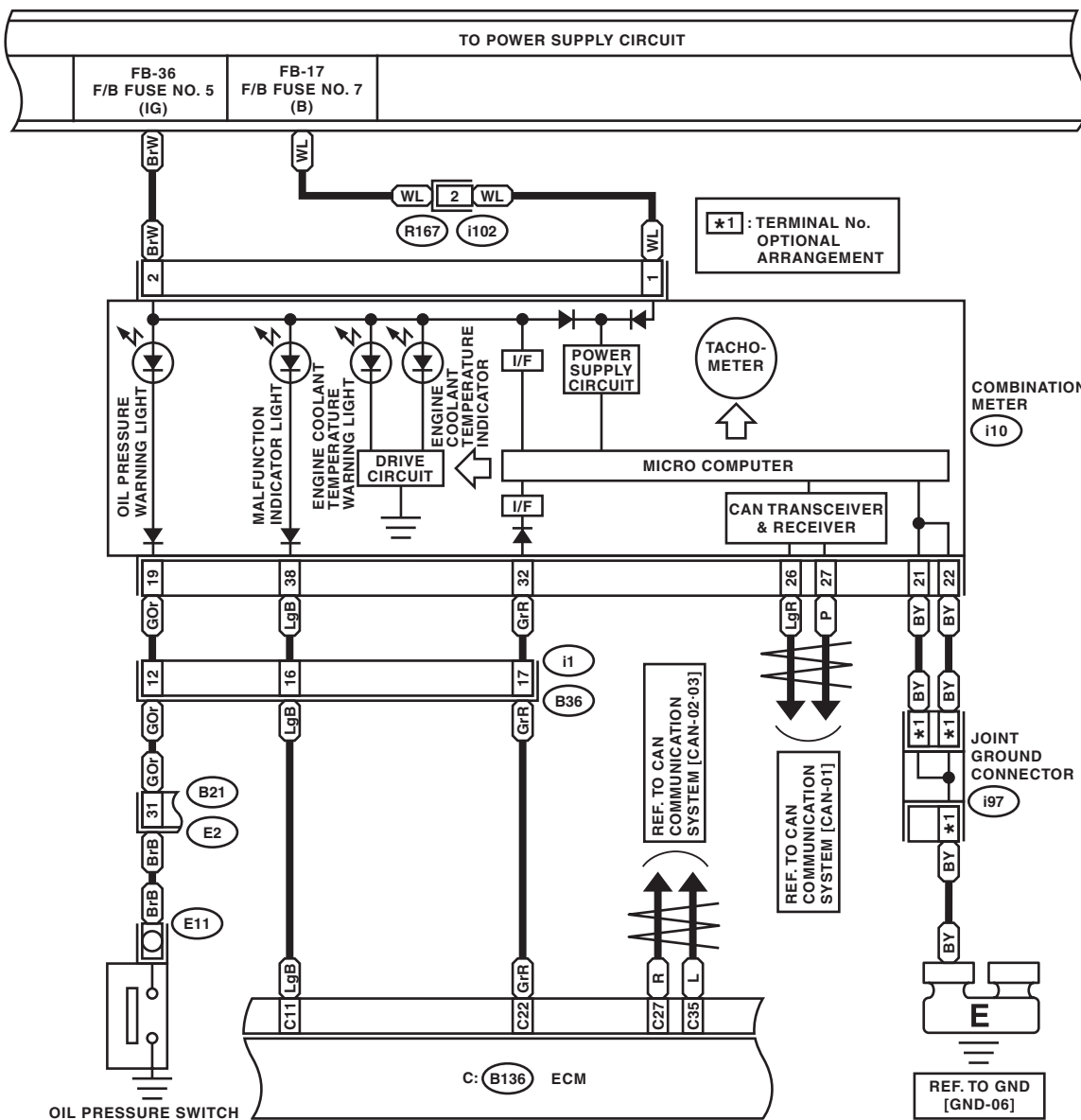

WI-16871

# Engine Electrical System

Brought to you by Eris Studios  
NOT FOR RESALE

## WIRING SYSTEM

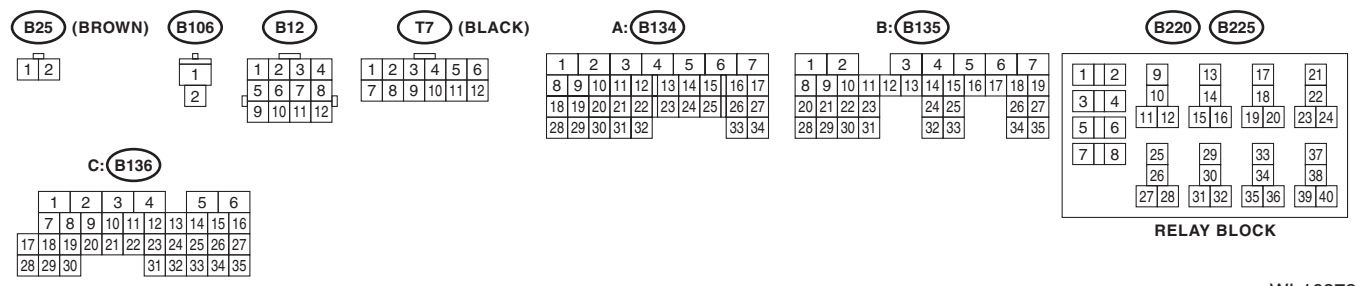
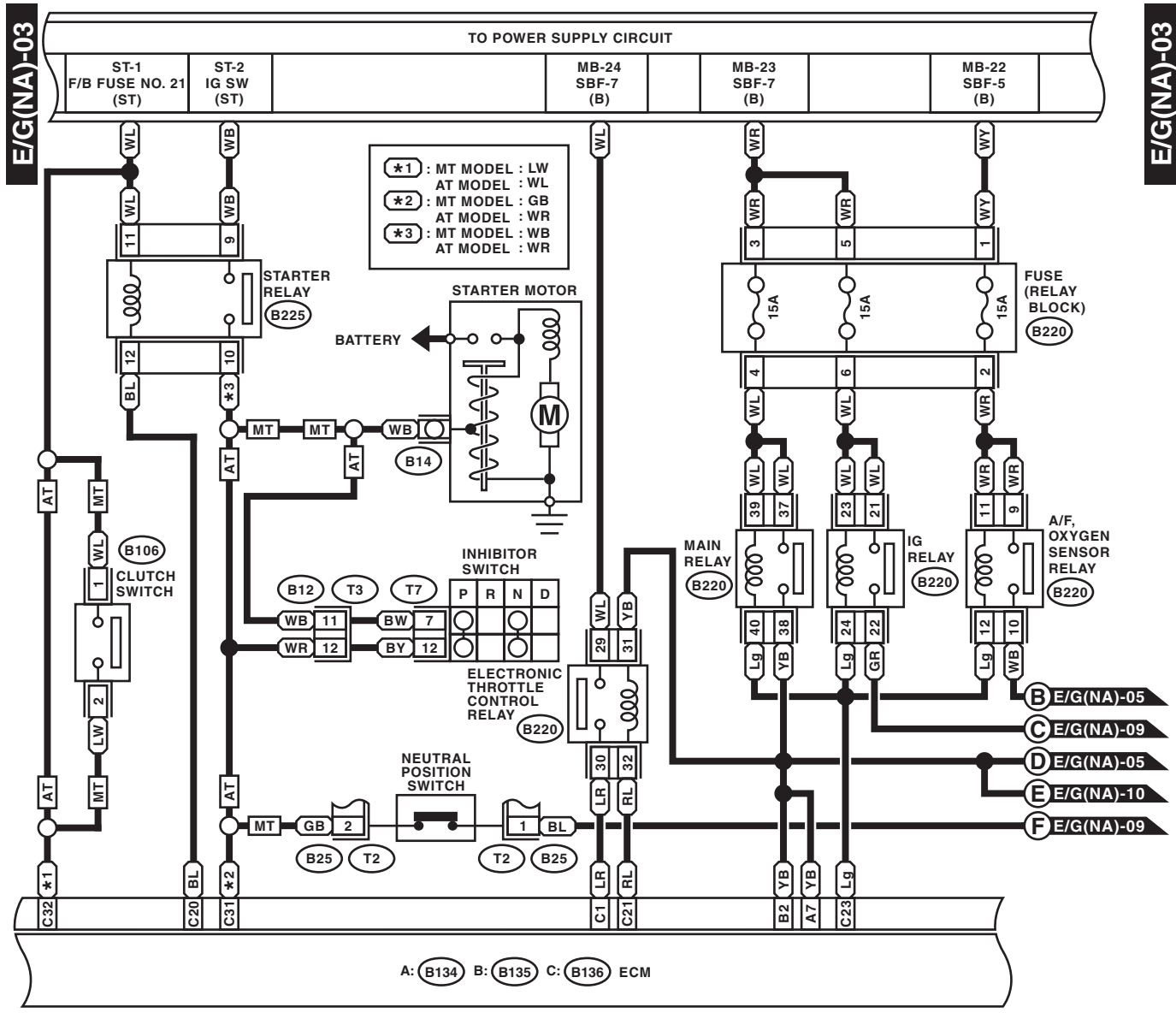

WI-16872

# Engine Electrical System

WIRING SYSTEM

Brought to you by *Chris Studios*  
 NOT FOR SALE

E/G(NA)-04

E/G(NA)-04

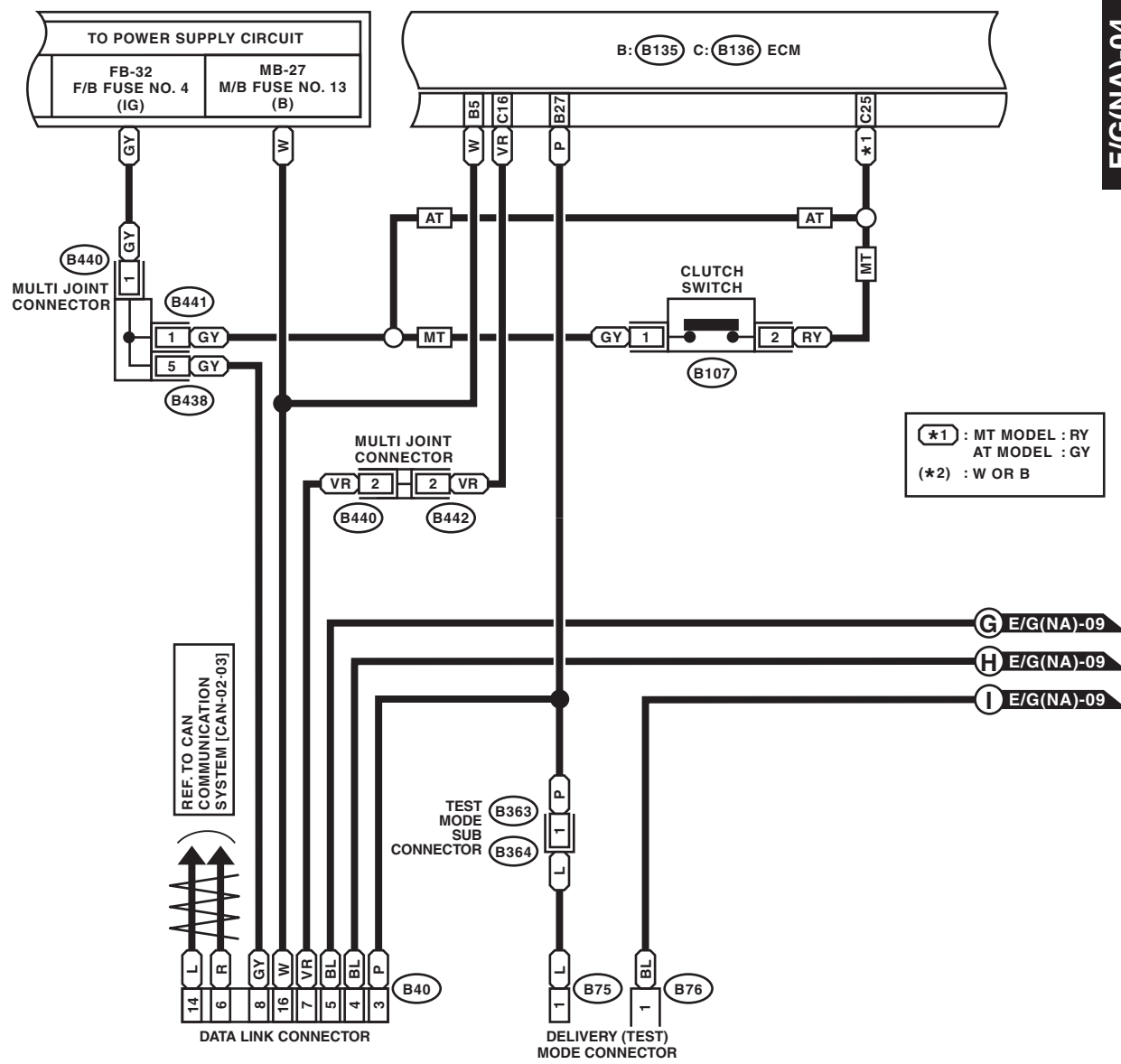

\*1 : MT MODEL : RY  
 AT MODEL : GY  
 (\*2) : W OR B

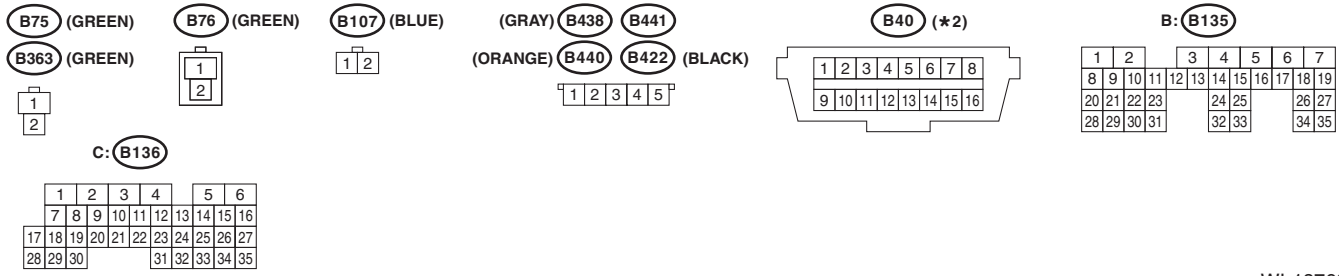

WI-18763

# Engine Electrical System

## WIRING SYSTEM

Brought to you by Eris Studios  
NOT FOR RESALE

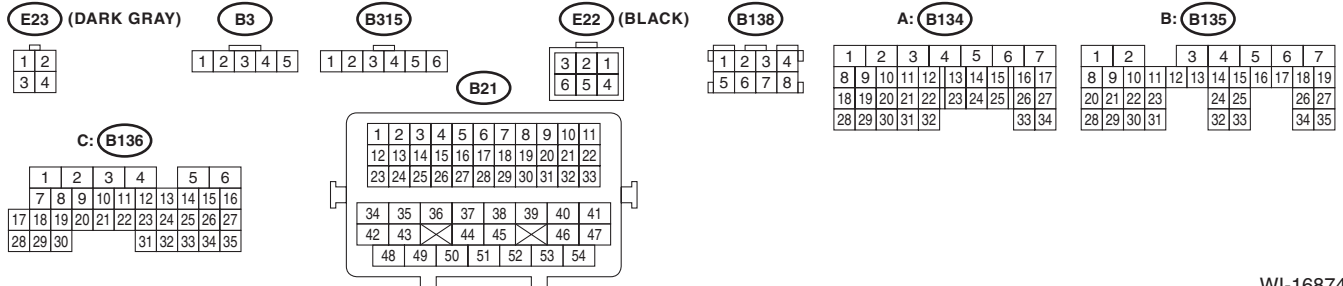
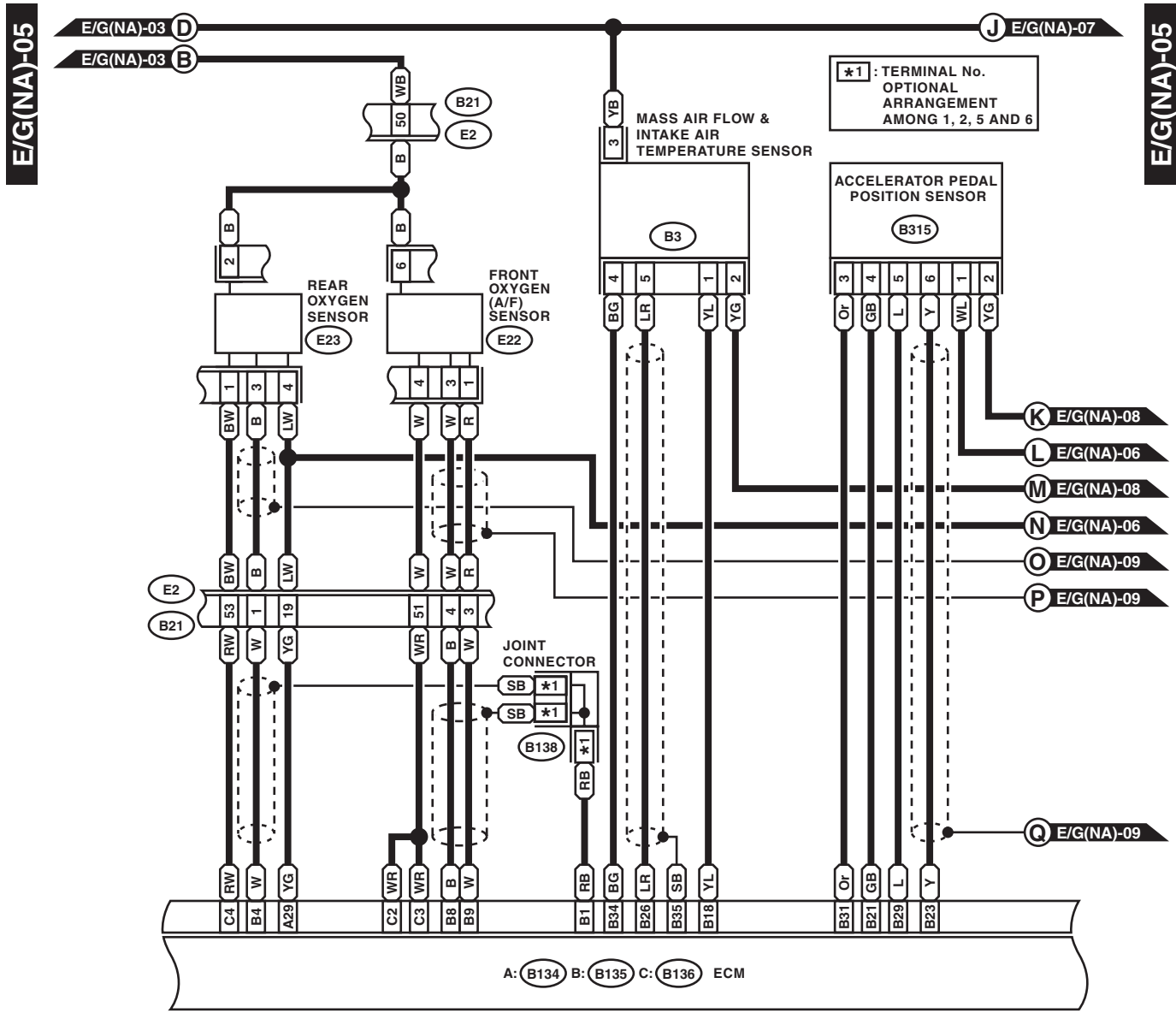

WI-16874



# Engine Electrical System

WIRING SYSTEM

Brought to you by *Chris Studios*  
 NOT FOR SALE

E/G(NA)-06

E/G(NA)-06

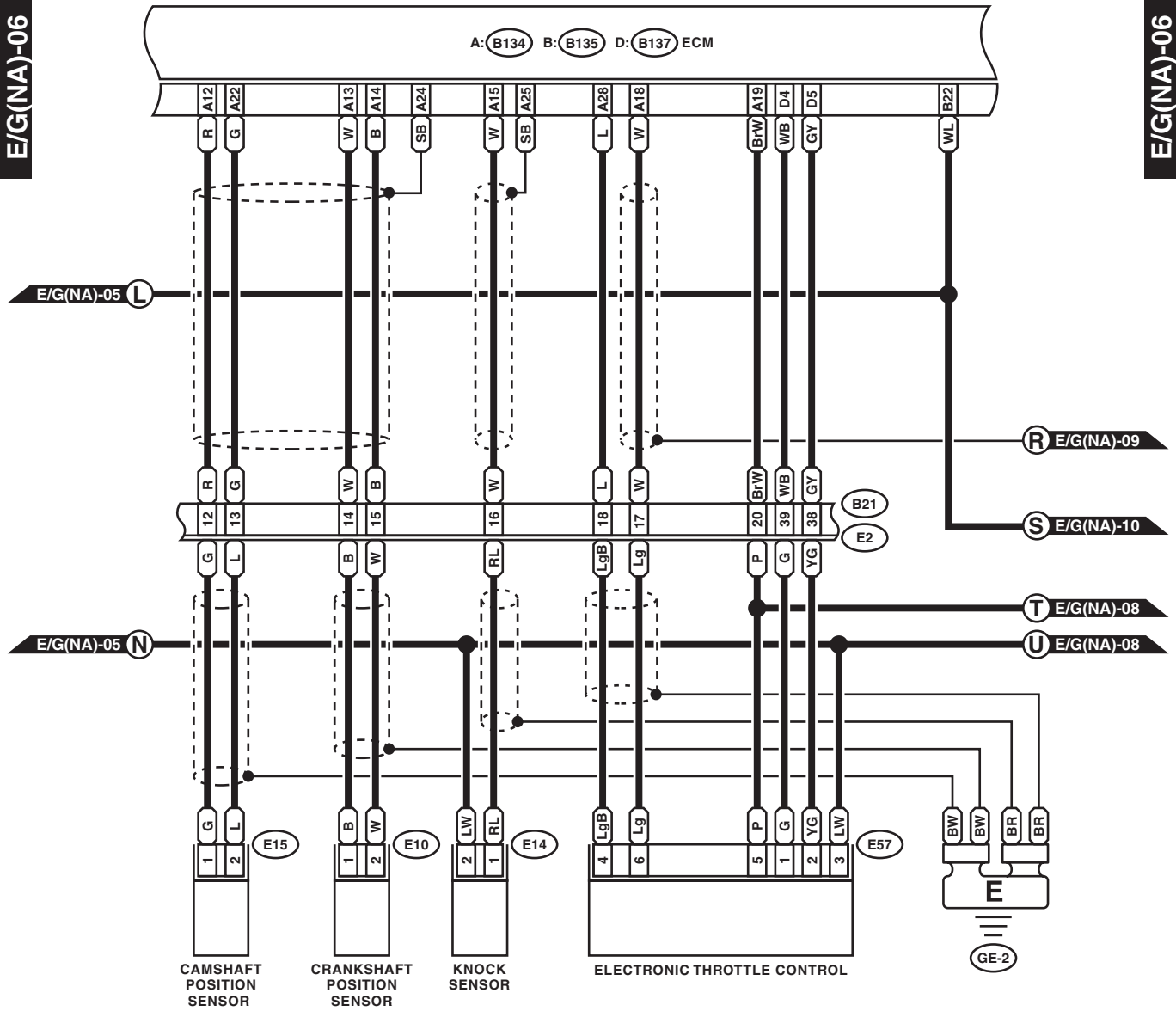

E10 (LIGHT GRAY)

E14 (GRAY)

E57 (BLACK)

D: B137

B21

E15 (BLACK)

1 2

1 2 3 4 5 6

1	2	3	4	5	6	7
8	9	10	11	12	13	14
15	16	17	18	19	20	21
22	23	24	25	26	27	28
29	30	31	32	33	34	35

1	2	3	4	5	6	7	8	9	10	11
12	13	14	15	16	17	18	19	20	21	22
23	24	25	26	27	28	29	30	31	32	33
34	35	36	37	38	39	40	41	42	43	44
45	46	47	48	49	50	51	52	53	54	

A: B134

1	2	3	4	5	6	7
8	9	10	11	12	13	14
15	16	17	18	19	20	21
22	23	24	25	26	27	28
29	30	31	32	33	34	

B: B135

1	2	3	4	5	6	7
8	9	10	11	12	13	14
15	16	17	18	19	20	21
22	23	24	25	26	27	28
29	30	31	32	33	34	35

WI-16875

# Engine Electrical System

WIRING SYSTEM

Brought to you by Eris Studios  
NOT FOR RESALE

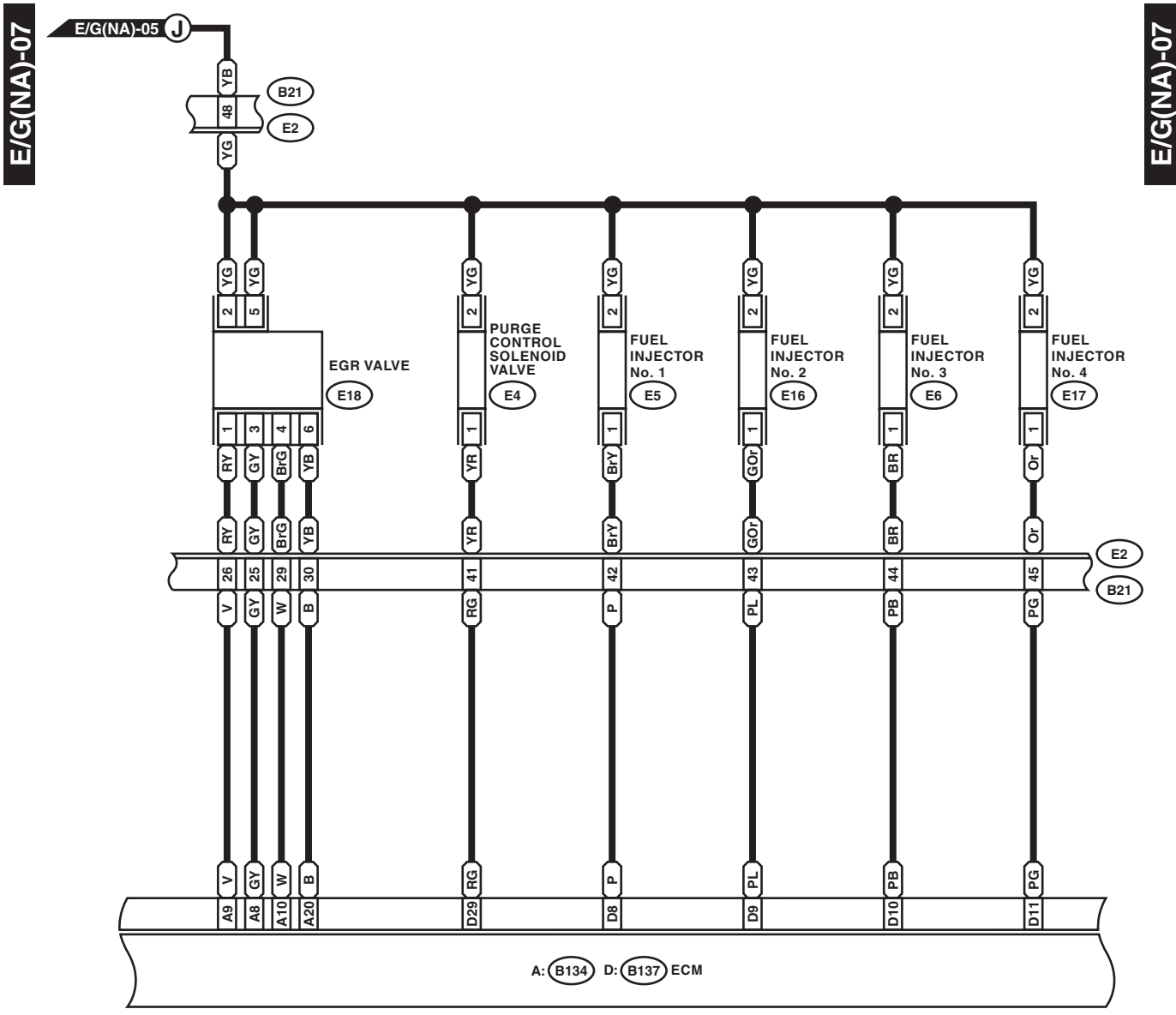

(E4) (BLACK)



(DARK GRAY) (E5) (E16) (DARK GRAY)

(DARK GRAY) (E6) (E17) (DARK GRAY)



(E18) (DARK GRAY) D: (B137)



A: (B134)

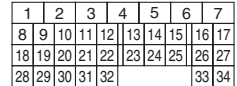

(B21)

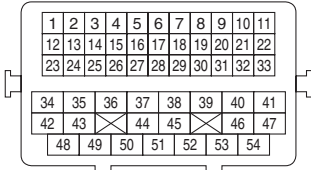

WI-16876

# Engine Electrical System

WIRING SYSTEM

Brought to you by *Chris Studios*  
 NOT FOR SALE

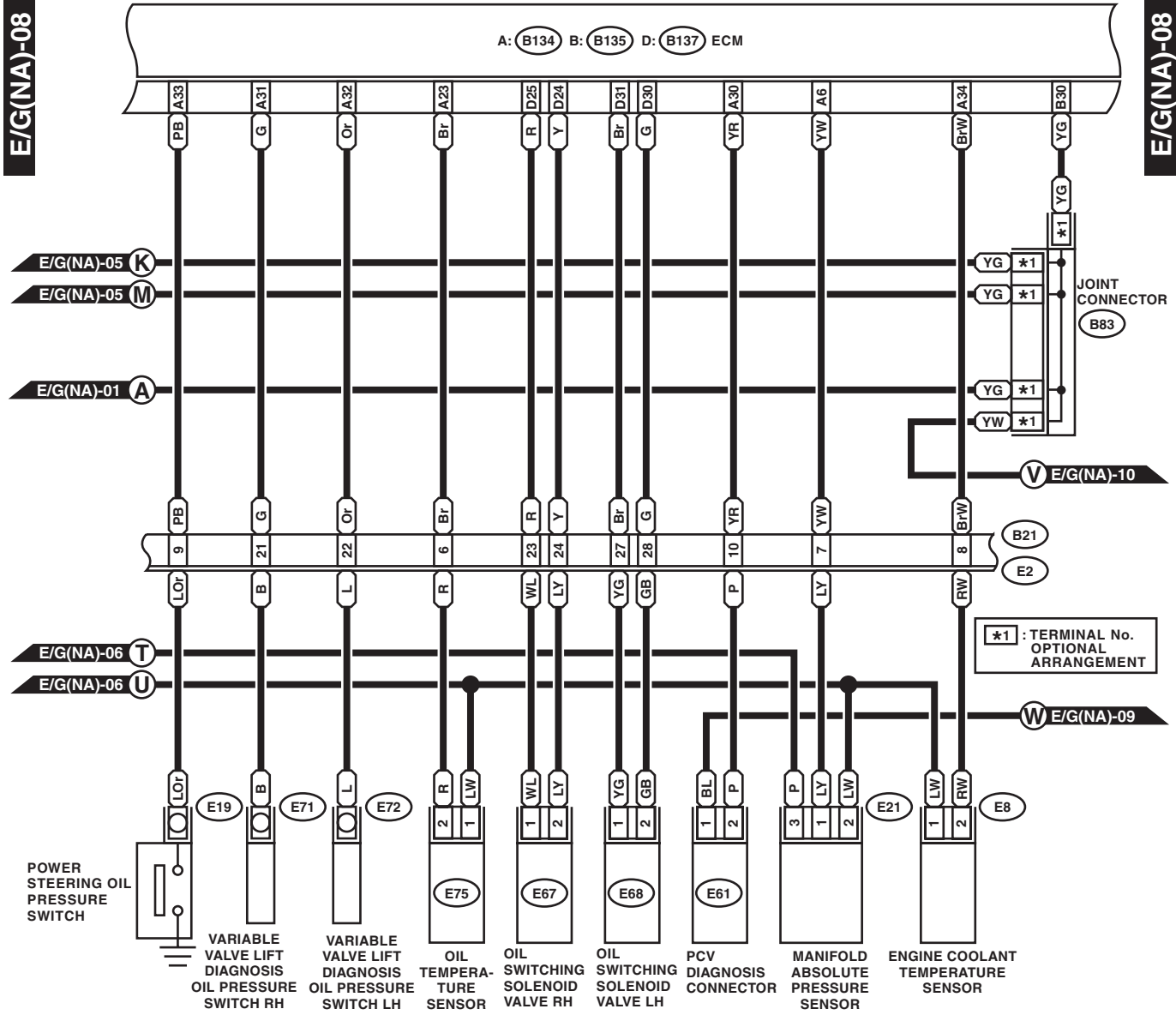

<b>E8 (BLACK)</b>	<b>E21 (BLACK)</b>	<b>B83</b>	<b>D: (B137)</b>	<b>A: (B134)</b>	<b>B21</b>																																																																																																																													
<b>E61 (DARK GRAY)</b>	<b>E75 (BLACK)</b>	<b>B: (B135)</b>	<table border="1"> <tr><td>1</td><td>2</td><td>3</td><td>4</td><td>5</td><td>6</td><td>7</td></tr> <tr><td>8</td><td>9</td><td>10</td><td>11</td><td>12</td><td>13</td><td>14</td></tr> <tr><td>15</td><td>16</td><td>17</td><td>18</td><td>19</td><td>20</td><td>21</td></tr> <tr><td>22</td><td>23</td><td>24</td><td>25</td><td>26</td><td>27</td><td>28</td></tr> <tr><td>29</td><td>30</td><td>31</td><td>32</td><td>33</td><td>34</td><td>35</td></tr> </table>	1	2	3	4	5	6	7	8	9	10	11	12	13	14	15	16	17	18	19	20	21	22	23	24	25	26	27	28	29	30	31	32	33	34	35	<table border="1"> <tr><td>1</td><td>2</td><td>3</td><td>4</td><td>5</td><td>6</td><td>7</td></tr> <tr><td>8</td><td>9</td><td>10</td><td>11</td><td>12</td><td>13</td><td>14</td></tr> <tr><td>15</td><td>16</td><td>17</td><td>18</td><td>19</td><td>20</td><td>21</td></tr> <tr><td>22</td><td>23</td><td>24</td><td>25</td><td>26</td><td>27</td><td>28</td></tr> <tr><td>29</td><td>30</td><td>31</td><td>32</td><td>33</td><td>34</td><td>35</td></tr> </table>	1	2	3	4	5	6	7	8	9	10	11	12	13	14	15	16	17	18	19	20	21	22	23	24	25	26	27	28	29	30	31	32	33	34	35	<table border="1"> <tr><td>1</td><td>2</td><td>3</td><td>4</td><td>5</td><td>6</td><td>7</td><td>8</td><td>9</td><td>10</td><td>11</td></tr> <tr><td>12</td><td>13</td><td>14</td><td>15</td><td>16</td><td>17</td><td>18</td><td>19</td><td>20</td><td>21</td><td>22</td></tr> <tr><td>23</td><td>24</td><td>25</td><td>26</td><td>27</td><td>28</td><td>29</td><td>30</td><td>31</td><td>32</td><td>33</td></tr> <tr><td>34</td><td>35</td><td>36</td><td>37</td><td>38</td><td>39</td><td>40</td><td>41</td><td>42</td><td>43</td><td>44</td></tr> <tr><td>45</td><td>46</td><td>47</td><td>48</td><td>49</td><td>50</td><td>51</td><td>52</td><td>53</td><td>54</td><td>55</td></tr> </table>	1	2	3	4	5	6	7	8	9	10	11	12	13	14	15	16	17	18	19	20	21	22	23	24	25	26	27	28	29	30	31	32	33	34	35	36	37	38	39	40	41	42	43	44	45	46	47	48	49	50	51	52	53	54	55
1	2	3	4	5	6	7																																																																																																																												
8	9	10	11	12	13	14																																																																																																																												
15	16	17	18	19	20	21																																																																																																																												
22	23	24	25	26	27	28																																																																																																																												
29	30	31	32	33	34	35																																																																																																																												
1	2	3	4	5	6	7																																																																																																																												
8	9	10	11	12	13	14																																																																																																																												
15	16	17	18	19	20	21																																																																																																																												
22	23	24	25	26	27	28																																																																																																																												
29	30	31	32	33	34	35																																																																																																																												
1	2	3	4	5	6	7	8	9	10	11																																																																																																																								
12	13	14	15	16	17	18	19	20	21	22																																																																																																																								
23	24	25	26	27	28	29	30	31	32	33																																																																																																																								
34	35	36	37	38	39	40	41	42	43	44																																																																																																																								
45	46	47	48	49	50	51	52	53	54	55																																																																																																																								

WI-16877

# Engine Electrical System

Brought to you by Eris Studios  
NOT FOR RESALE

## WIRING SYSTEM

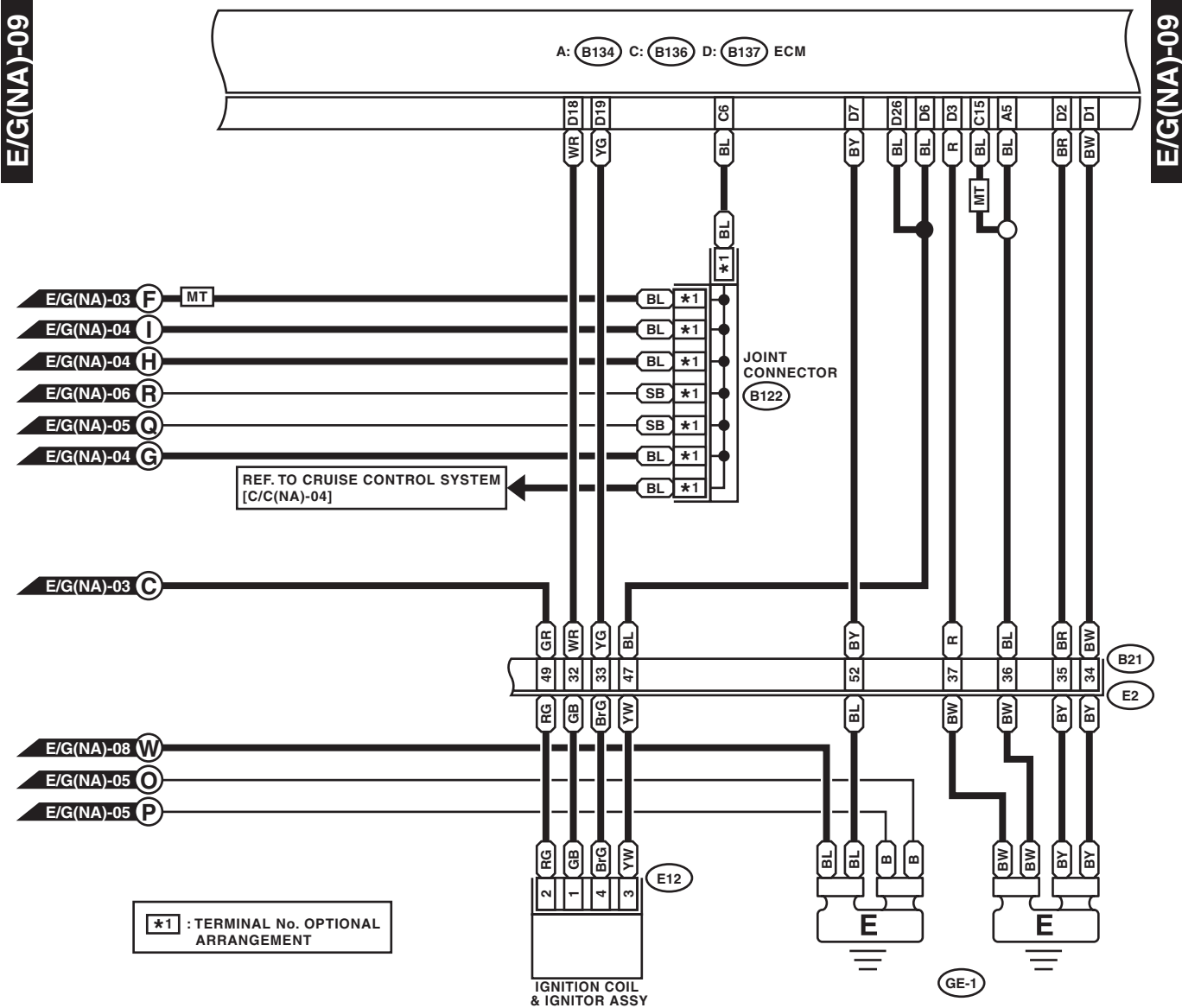

E12 (DARK GRAY)

B122

D: B137

A: B134

C: B136

1	2	3	4
---	---	---	---

1	2	3	4
5	6	7	8

B21

1	2	3	4	5	6	7
8	9	10	11	12	13	14
15	16	17	18	19	20	21
22	23	24	25	26	27	28
29	30	31				

1	2	3	4	5	6	7
8	9	10	11	12	13	14
15	16	17	18	19	20	21
22	23	24	25	26	27	28
29	30	31	32	33	34	

1	2	3	4	5	6
7	8	9	10	11	12
13	14	15	16	17	18
19	20	21	22	23	24
25	26	27	28	29	30
31	32	33	34	35	

1	2	3	4	5	6	7	8	9	10	11
12	13	14	15	16	17	18	19	20	21	22
23	24	25	26	27	28	29	30	31	32	33
34	35	36	37	38	39	40	41			
42	43	44	45	46	47					
48	49	50	51	52	53	54				

WI-16878

# Engine Electrical System

WIRING SYSTEM

Brought to you by *Chris Studios*  
 NOT FOR SALE

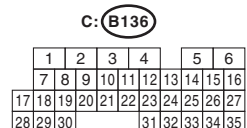
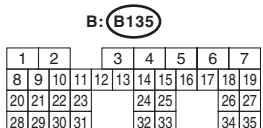
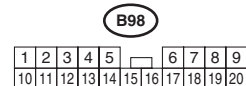
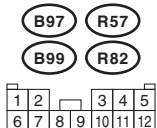
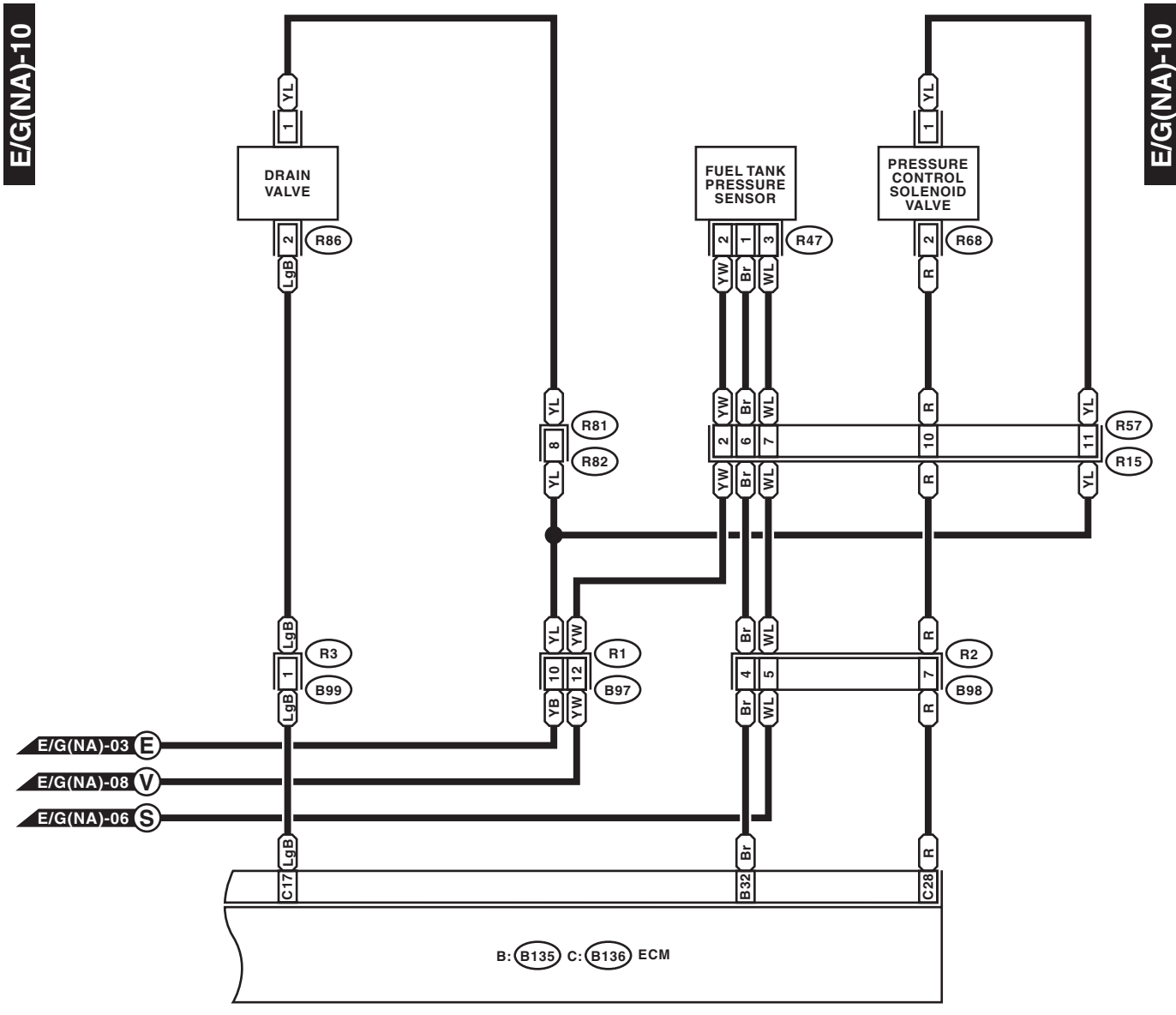

WI-16879

# Engine Electrical System

Brought to you by Eris Studios  
NOT FOR RESALE

## WIRING SYSTEM

- Transmission serial No. 4078113 or later

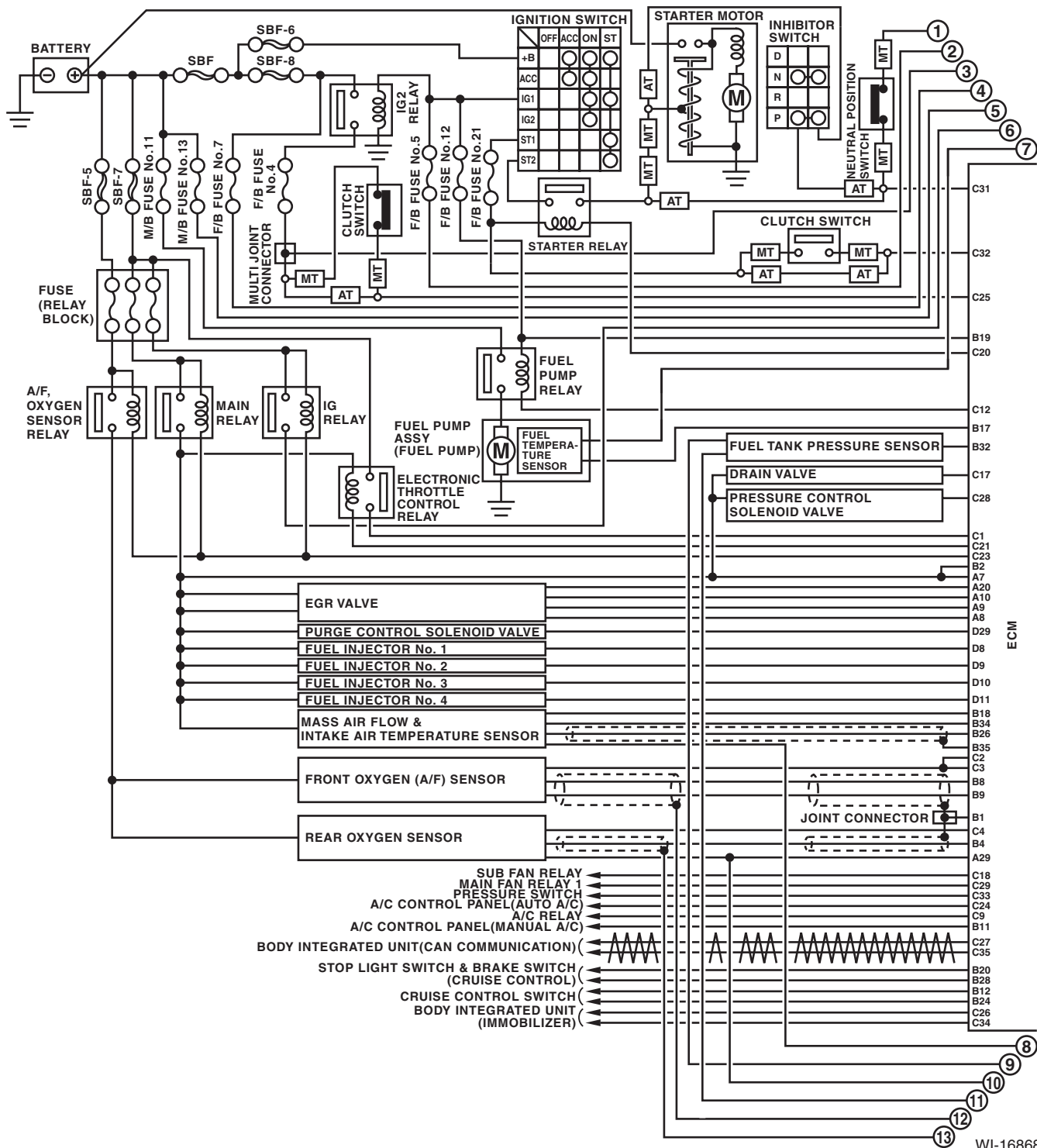

WI-16868

# Engine Electrical System

WIRING SYSTEM

Brought to you by *Chris Studios*  
NOT FOR SALE

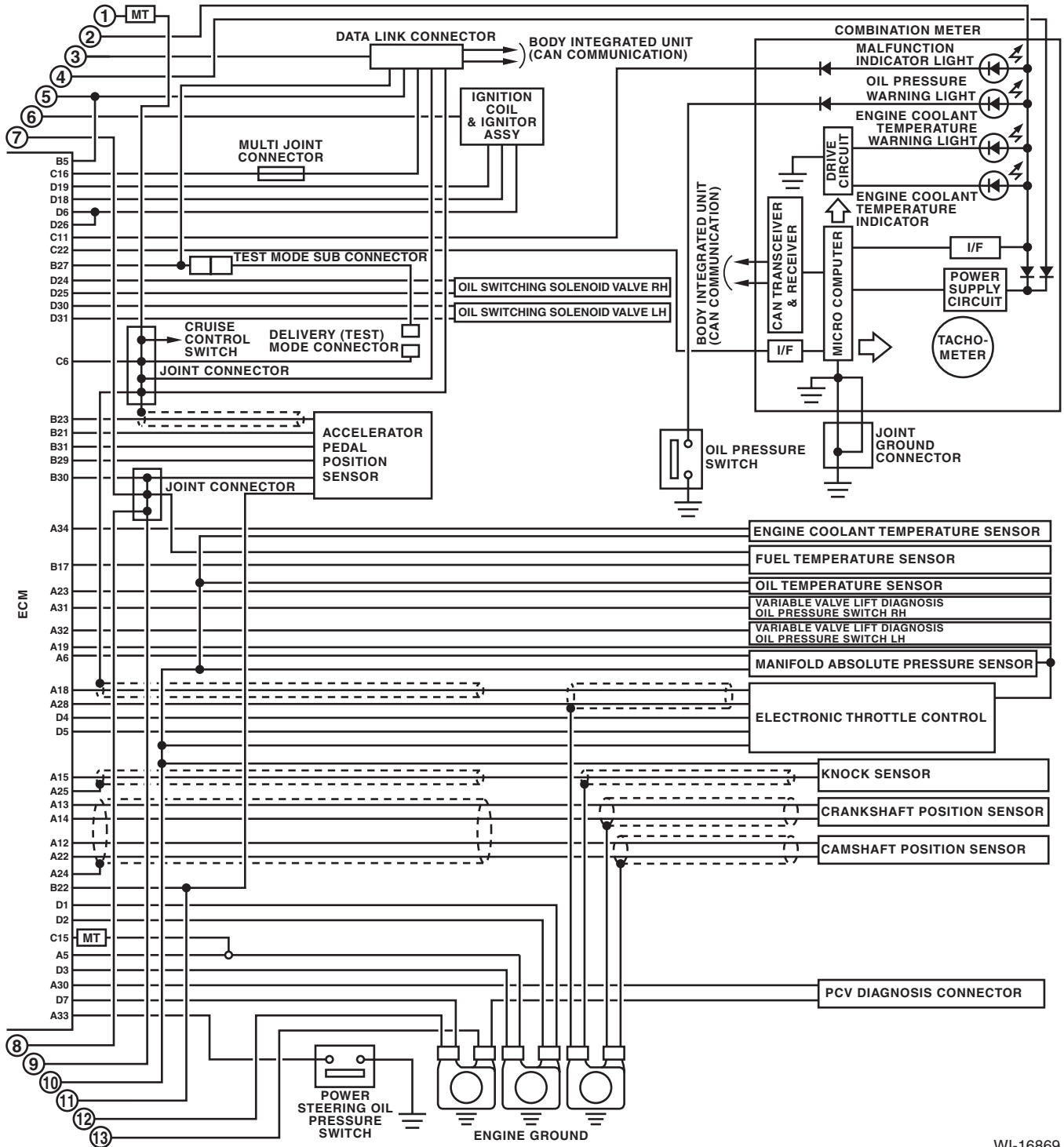

WI-16869

# Engine Electrical System

Brought to you by Eris Studios  
NOT FOR RESALE

## WIRING SYSTEM

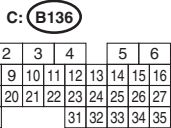
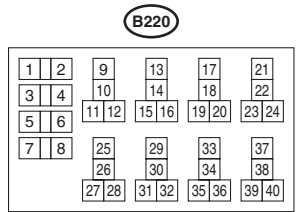
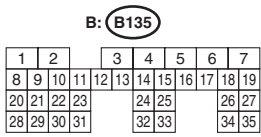
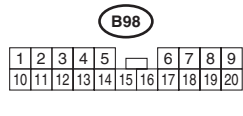
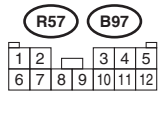
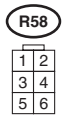
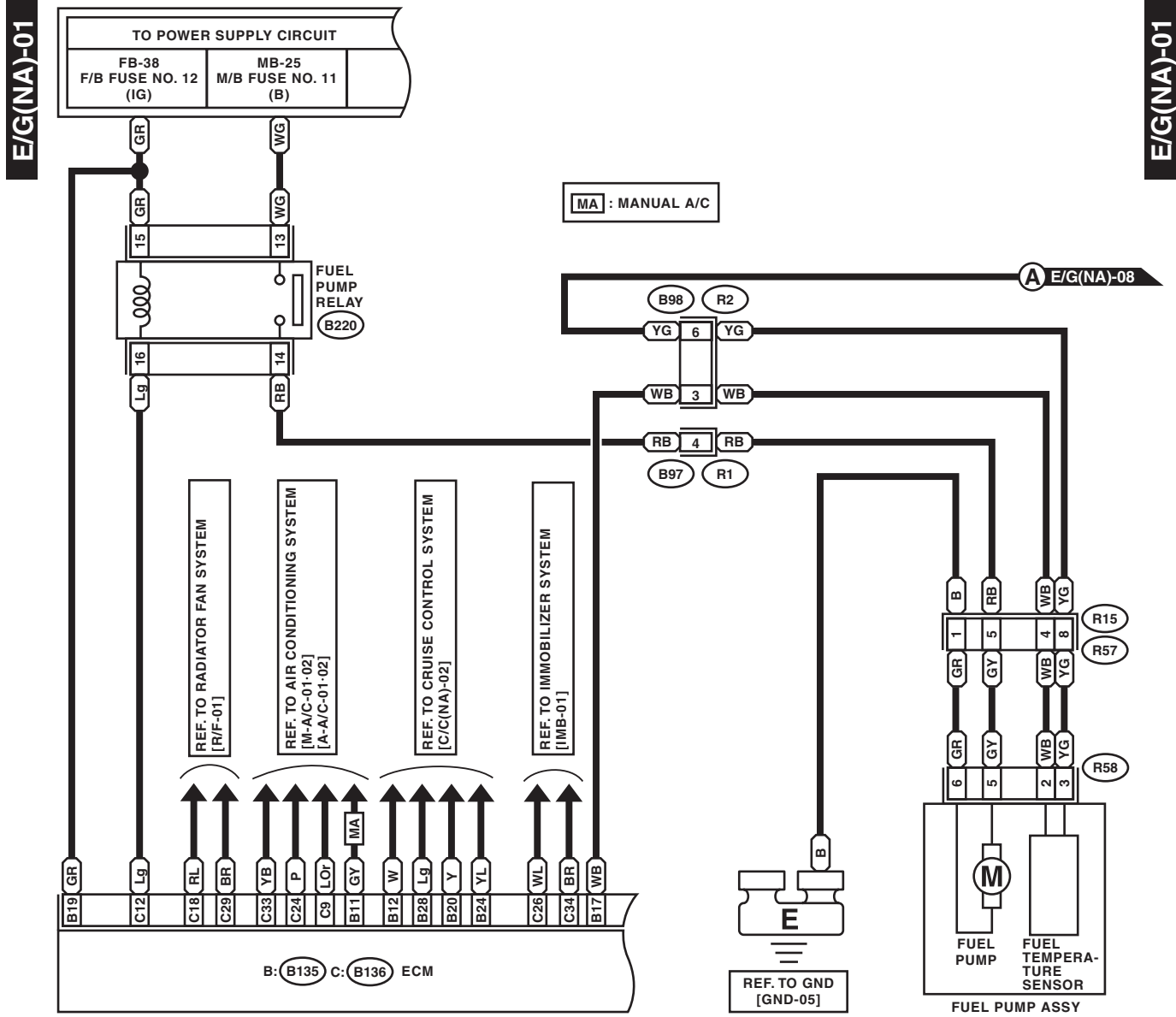

RELAY BLOCK

WI-16870



# Engine Electrical System

WIRING SYSTEM

Brought to you by *Chris Studios*  
NOT FOR SALE

E/G(NA)-02

E/G(NA)-02

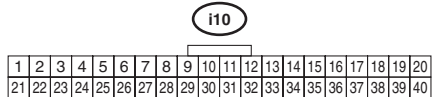
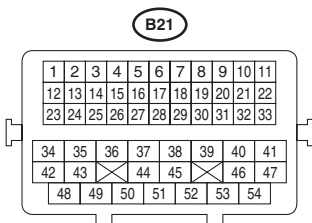
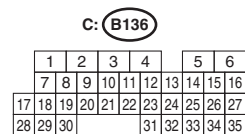
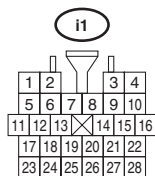
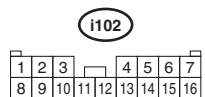
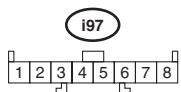
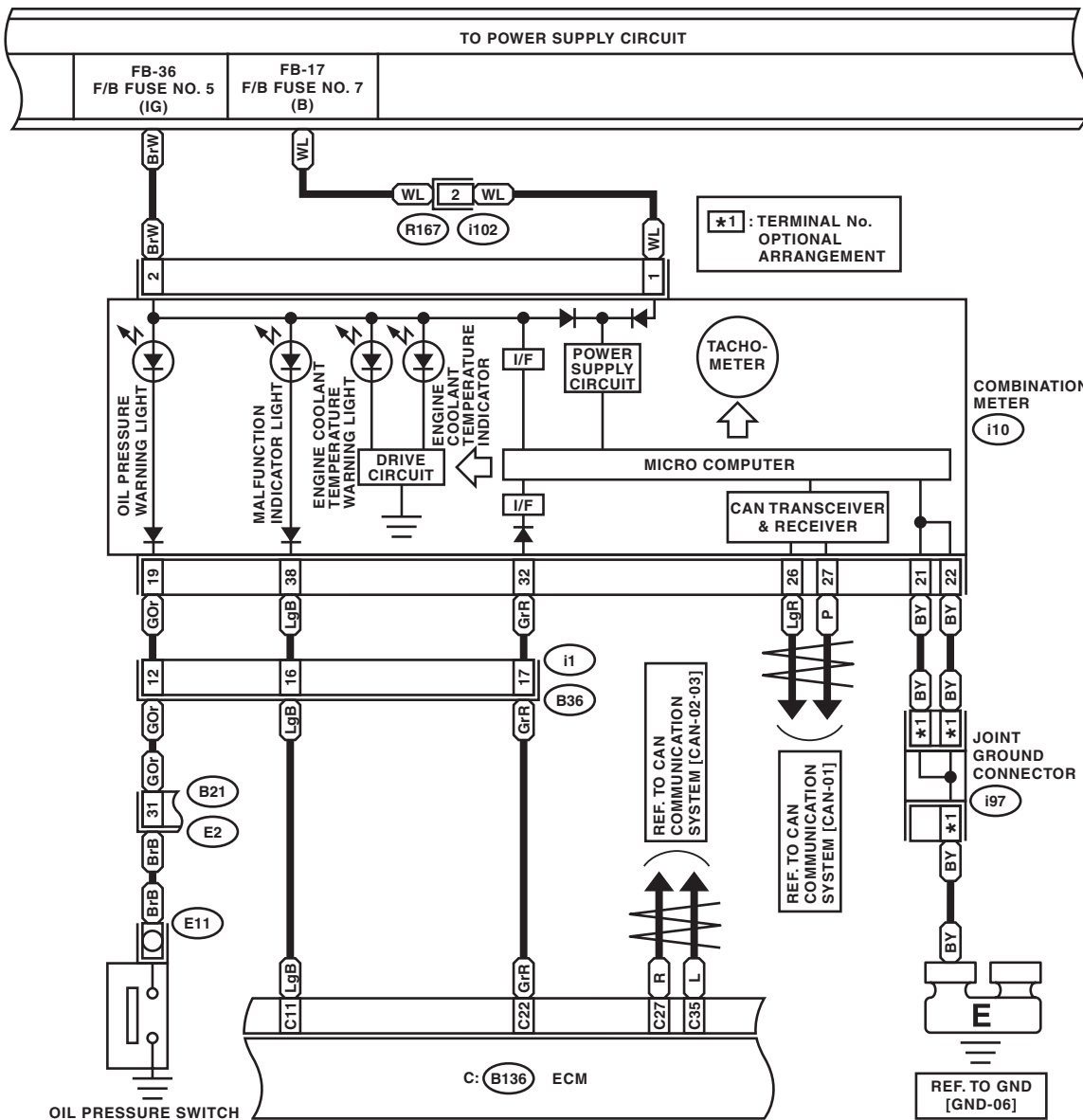

WI-16871

# Engine Electrical System

Brought to you by Eris Studios  
NOT FOR RESALE

## WIRING SYSTEM

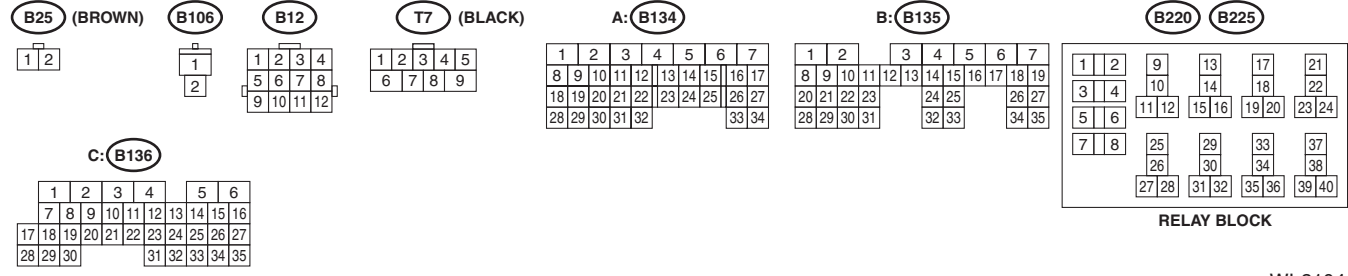
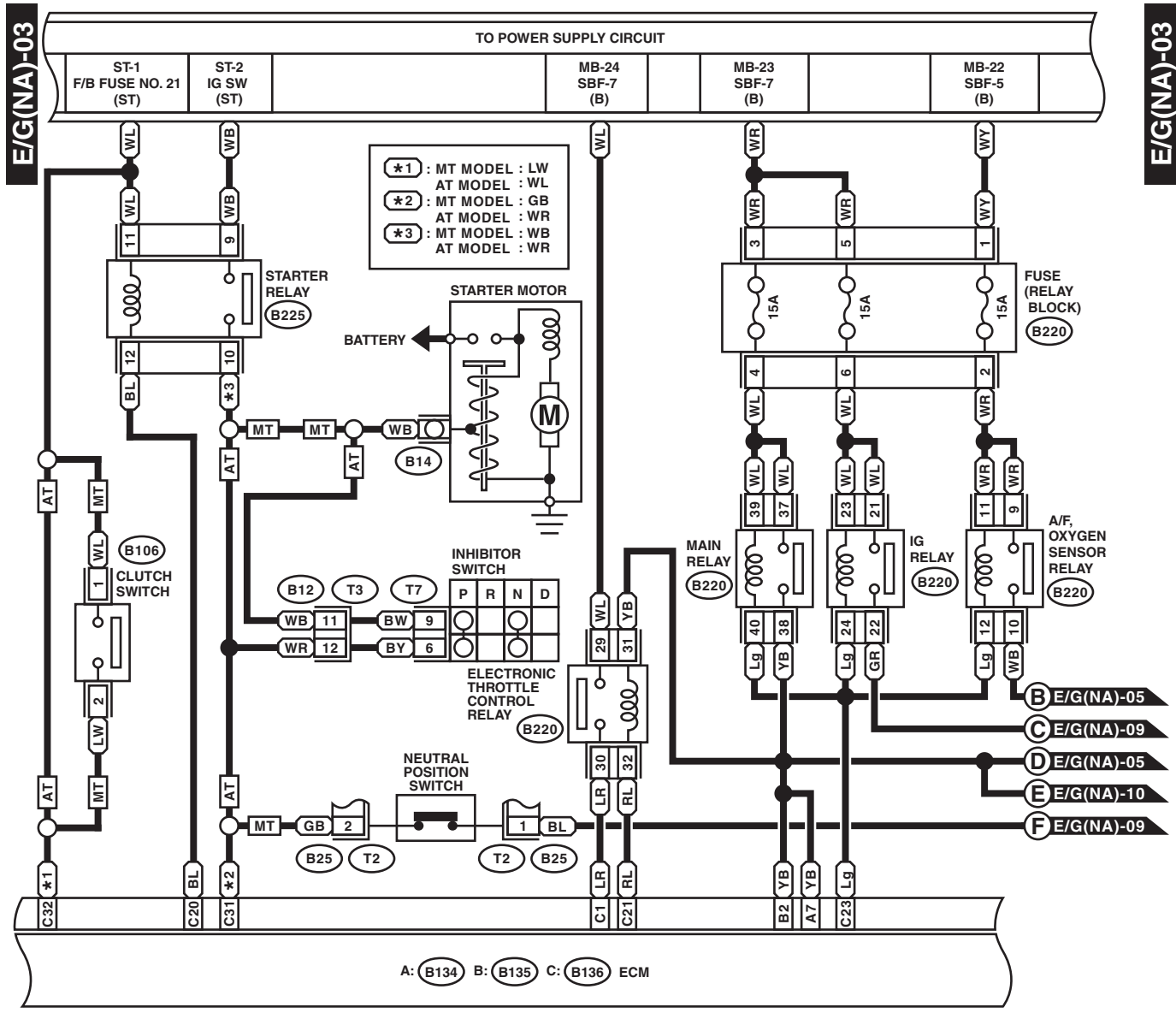

WI-21041

# Engine Electrical System

WIRING SYSTEM

Brought to you by *Chris Studios*  
NOT FOR SALE

E/G(NA)-04

E/G(NA)-04

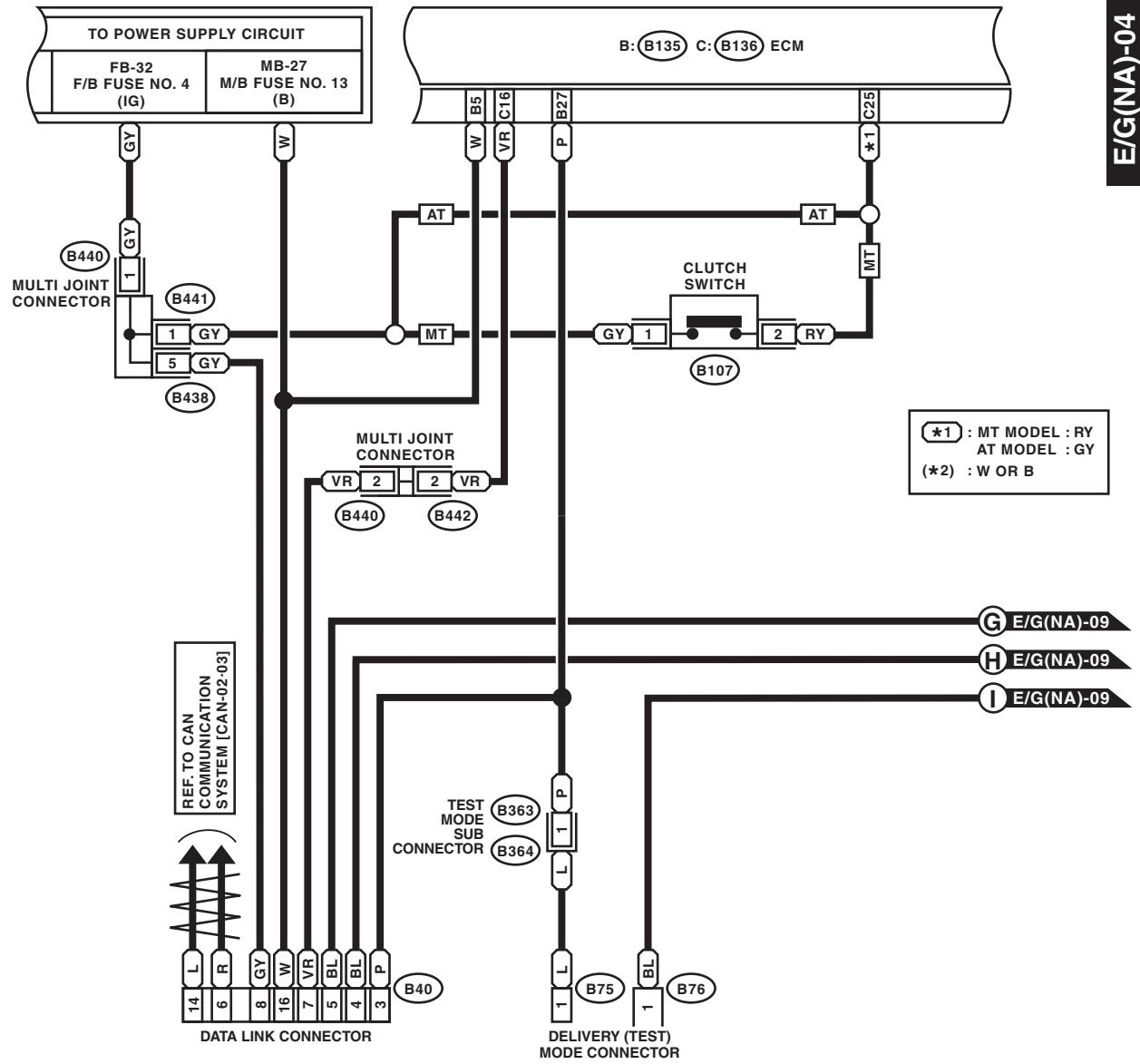

\*1 : MT MODEL : RY  
AT MODEL : GY  
(\*2) : W OR B

G E/G(NA)-09  
H E/G(NA)-09  
I E/G(NA)-09

REF. TO CAN COMMUNICATION SYSTEM [CAN-02-03]

TEST MODE SUB CONNECTOR  
B363  
B364

DATA LINK CONNECTOR  
B40

DELIVERY (TEST) MODE CONNECTOR  
B75  
B76

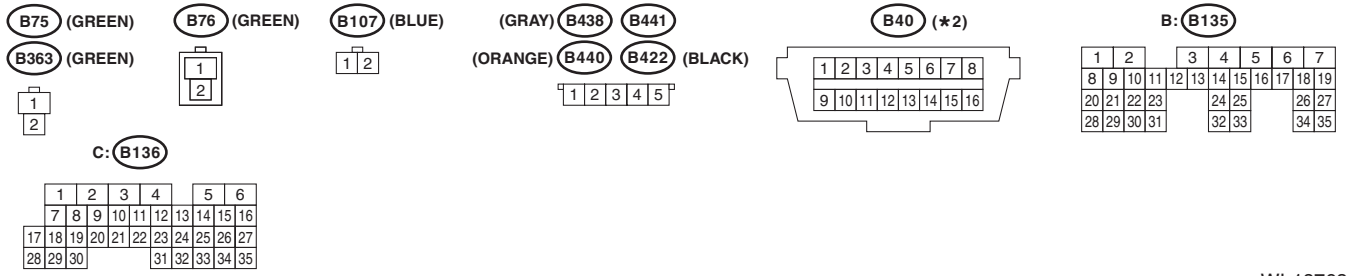

WI-18763

# Engine Electrical System

## WIRING SYSTEM

Brought to you by Eris Studios  
NOT FOR RESALE

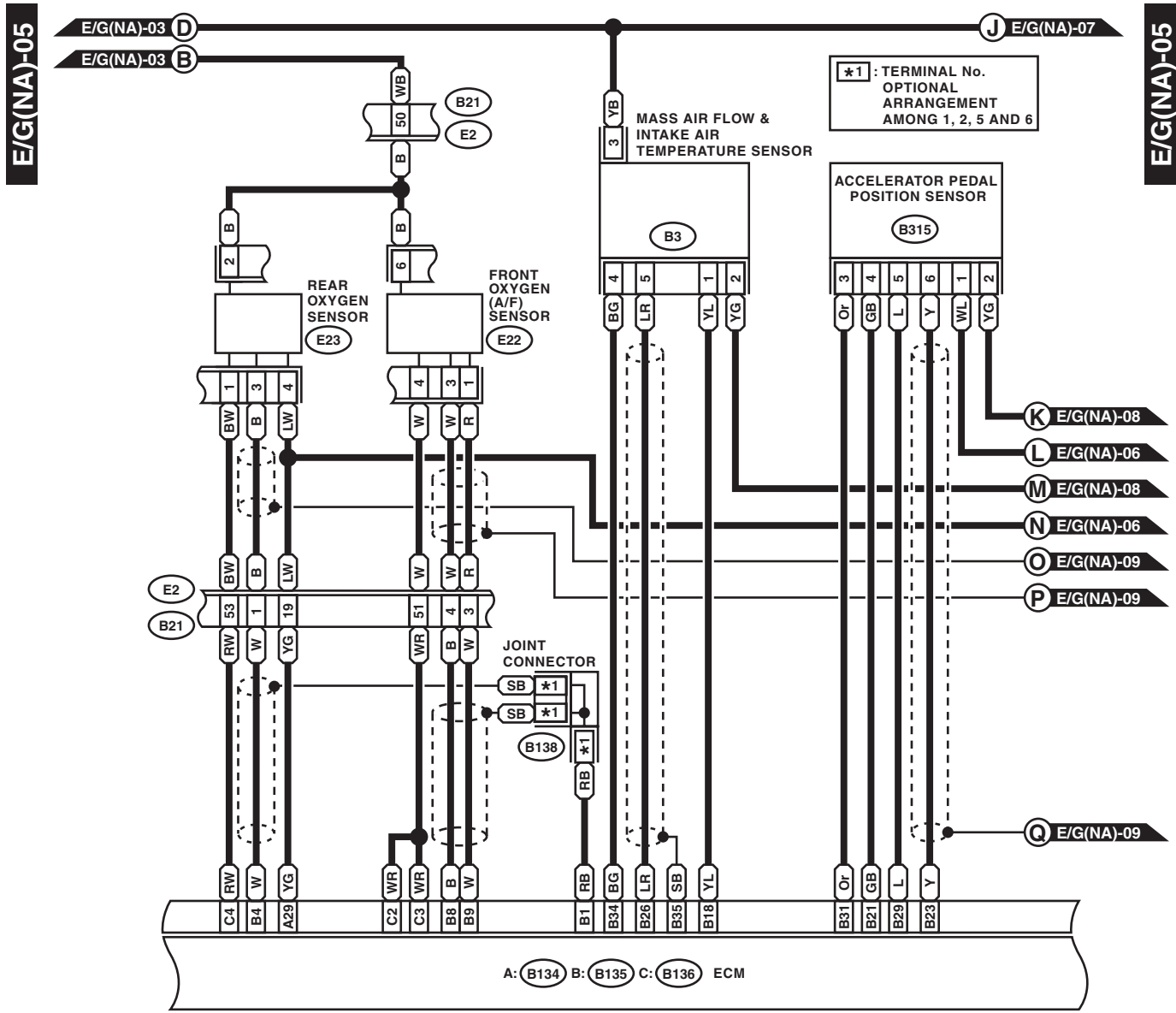

\*1 : TERMINAL No.  
OPTIONAL  
ARRANGEMENT  
AMONG 1, 2, 5 AND 6

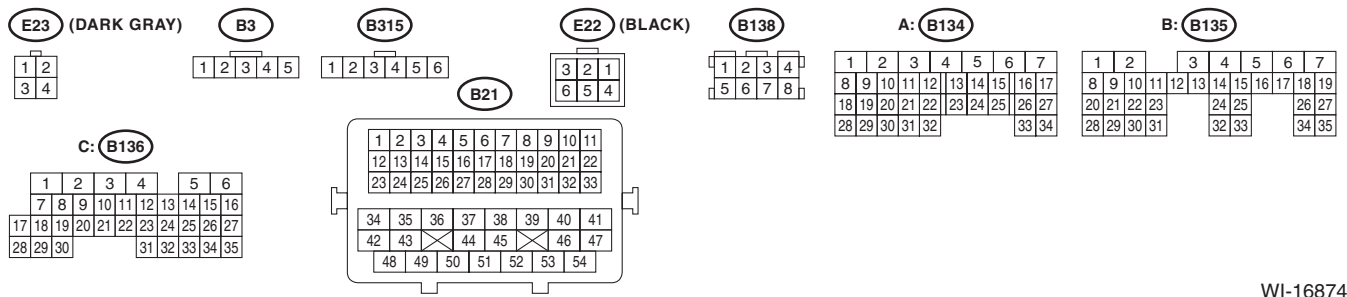

WI-16874

# Engine Electrical System

WIRING SYSTEM

Brought to you by *Chris Studios*  
NOT FOR SALE

E/G(NA)-06

E/G(NA)-06

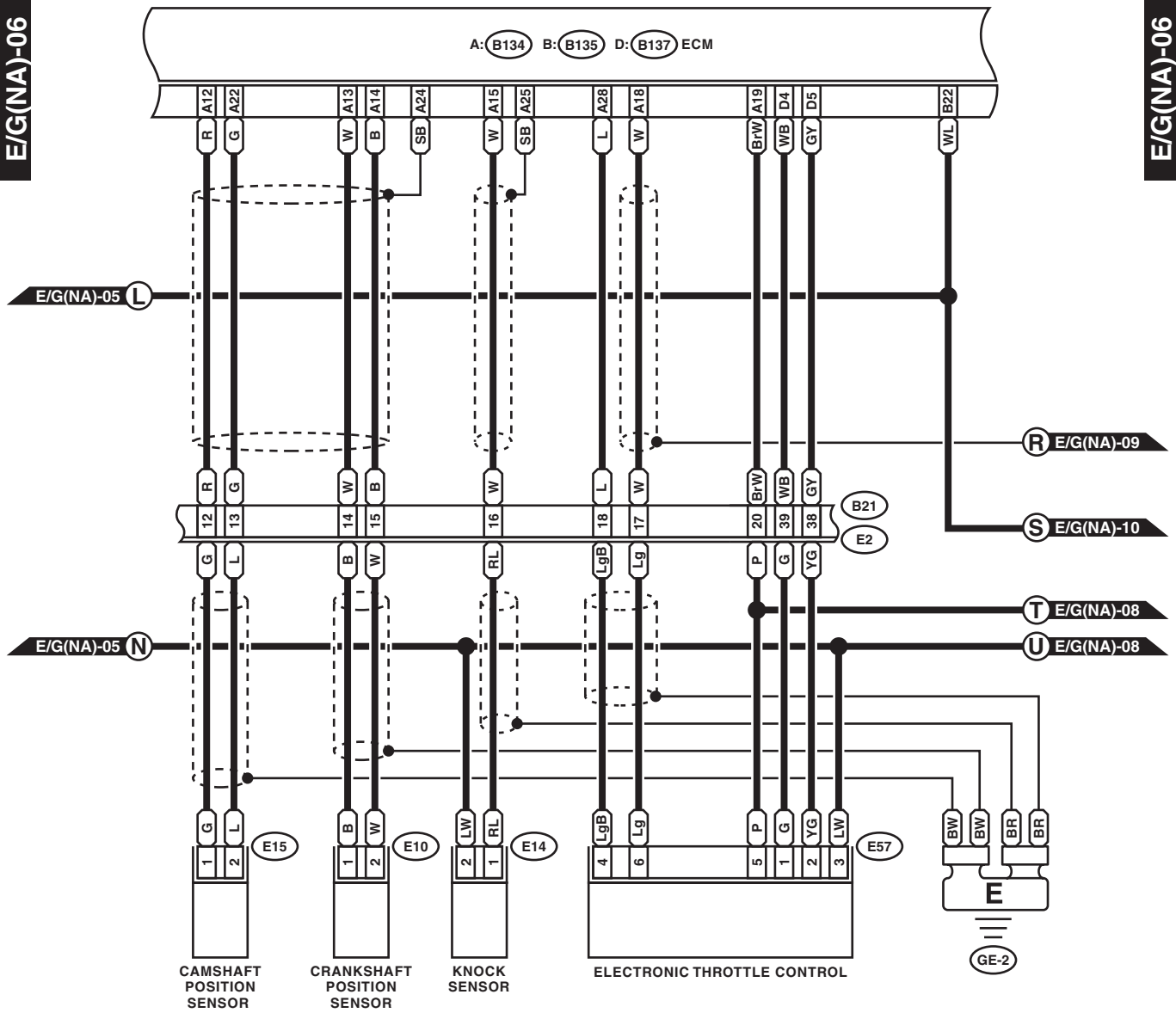

E10 (LIGHT GRAY)

E14 (GRAY)

E57 (BLACK)

D: B137

B21

E15 (BLACK)

1 2

1 2 3 4 5 6

1	2	3	4	5	6	7
8	9	10	11	12	13	14
15	16	17	18	19	20	21
22	23	24	25	26	27	28
29	30	31	32	33	34	35

1	2	3	4	5	6	7	8	9	10	11
12	13	14	15	16	17	18	19	20	21	22
23	24	25	26	27	28	29	30	31	32	33
34	35	36	37	38	39	40	41	42	43	44
45	46	47	48	49	50	51	52	53	54	

A: B134

1	2	3	4	5	6	7
8	9	10	11	12	13	14
15	16	17	18	19	20	21
22	23	24	25	26	27	28
29	30	31	32	33	34	

B: B135

1	2	3	4	5	6	7
8	9	10	11	12	13	14
15	16	17	18	19	20	21
22	23	24	25	26	27	28
29	30	31	32	33	34	35

WI-16875

# Engine Electrical System

WIRING SYSTEM

Brought to you by Eris Studios  
NOT FOR RESALE

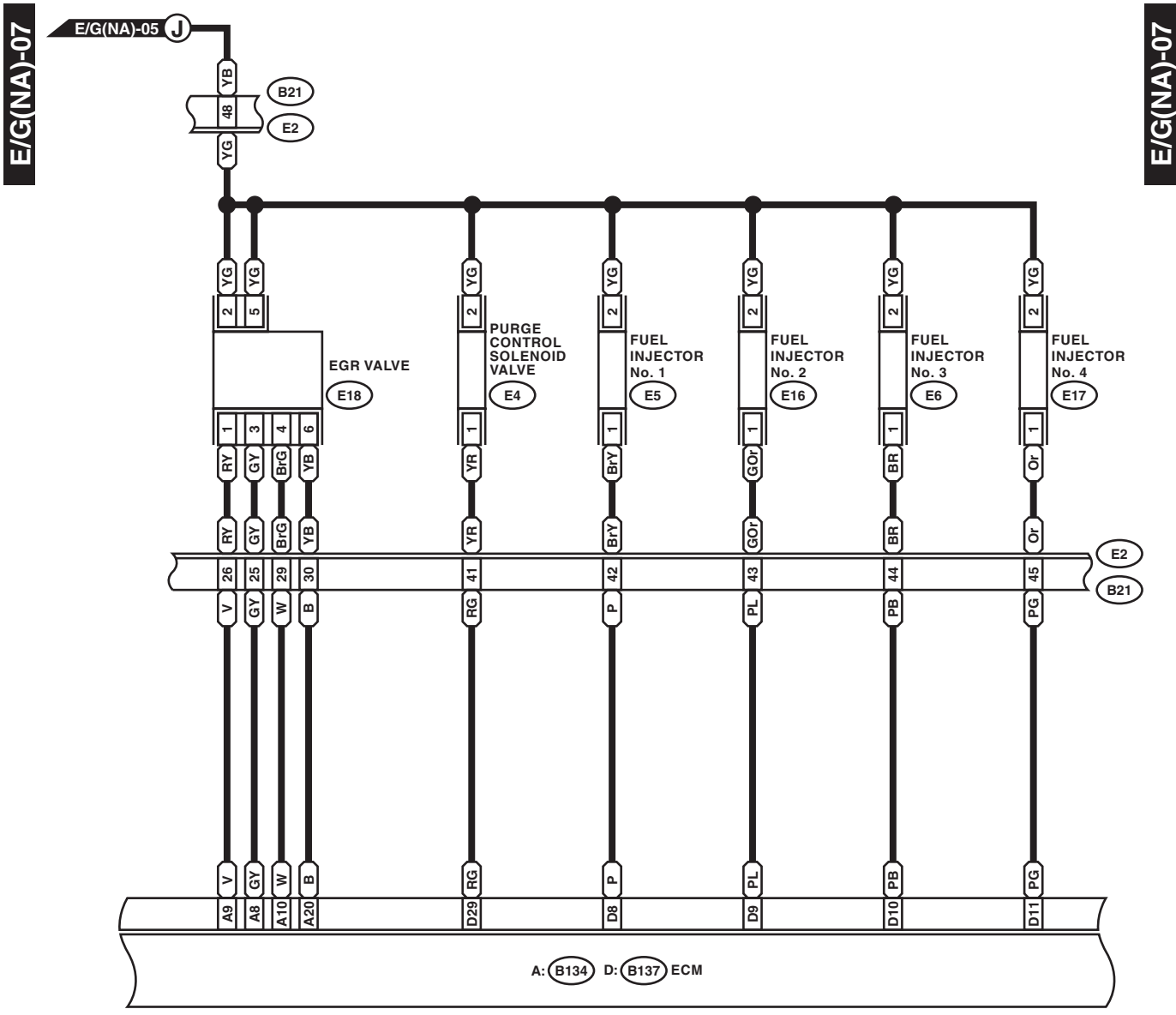

**E4** (BLACK)



(DARK GRAY) **E5**    **E16** (DARK GRAY)

(DARK GRAY) **E6**    **E17** (DARK GRAY)



**E18** (DARK GRAY)    D: **B137**



A: **B134**

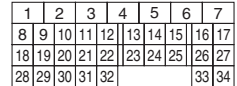

**B21**

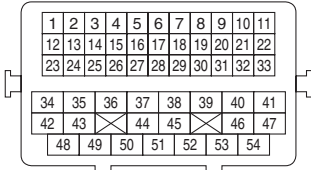

WI-16876

# Engine Electrical System

WIRING SYSTEM

Brought to you by *Chris Studios*  
 NOT FOR SALE

E/G(NA)-08

E/G(NA)-08

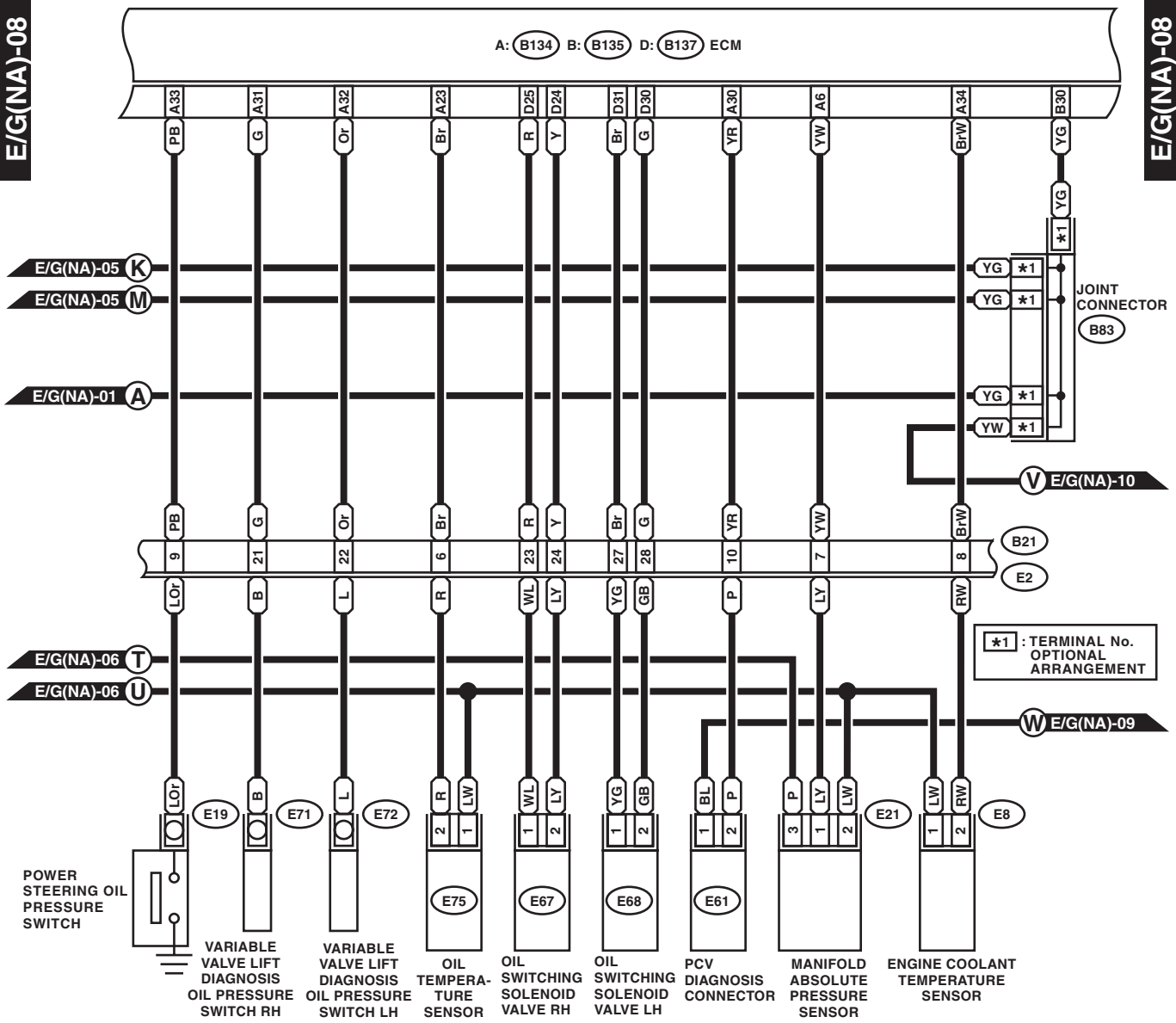

\*1 : TERMINAL No. OPTIONAL ARRANGEMENT

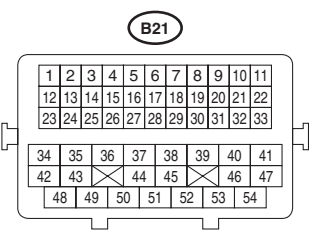
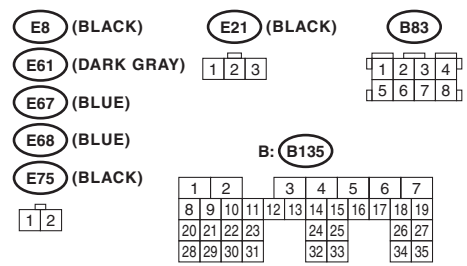

WI-16877

# Engine Electrical System

## WIRING SYSTEM

Brought to you by Eris Studios  
NOT FOR RESALE

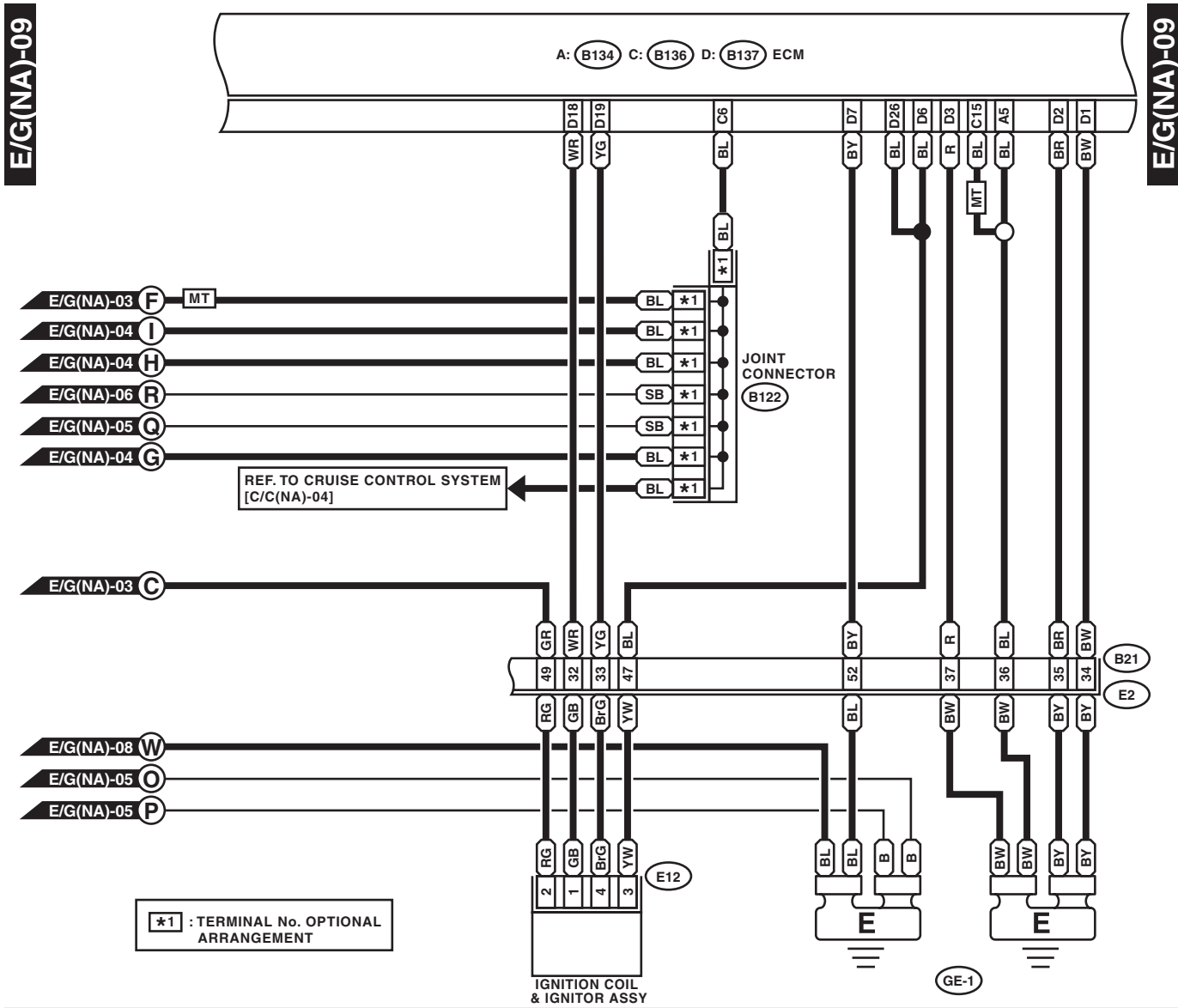

E12 (DARK GRAY)

B122

D: B137

A: B134

C: B136

1	2	3	4
---	---	---	---

1	2	3	4
5	6	7	8

1	2	3	4	5	6	7
8	9	10	11	12	13	14
15	16	17	18	19	20	21
22	23	24	25	26	27	28
29	30	31	32	33	34	35

1	2	3	4	5	6	7
8	9	10	11	12	13	14
15	16	17	18	19	20	21
22	23	24	25	26	27	28
29	30	31	32	33	34	35

1	2	3	4	5	6
7	8	9	10	11	12
13	14	15	16	17	18
19	20	21	22	23	24
25	26	27	28	29	30
31	32	33	34	35	36

1	2	3	4	5	6	7	8	9	10	11
12	13	14	15	16	17	18	19	20	21	22
23	24	25	26	27	28	29	30	31	32	33
34	35	36	37	38	39	40	41	42	43	44
45	46	47	48	49	50	51	52	53	54	55

WI-16878



# Engine Electrical System

WIRING SYSTEM

Brought to you by *Chris Studios*  
 NOT FOR SALE

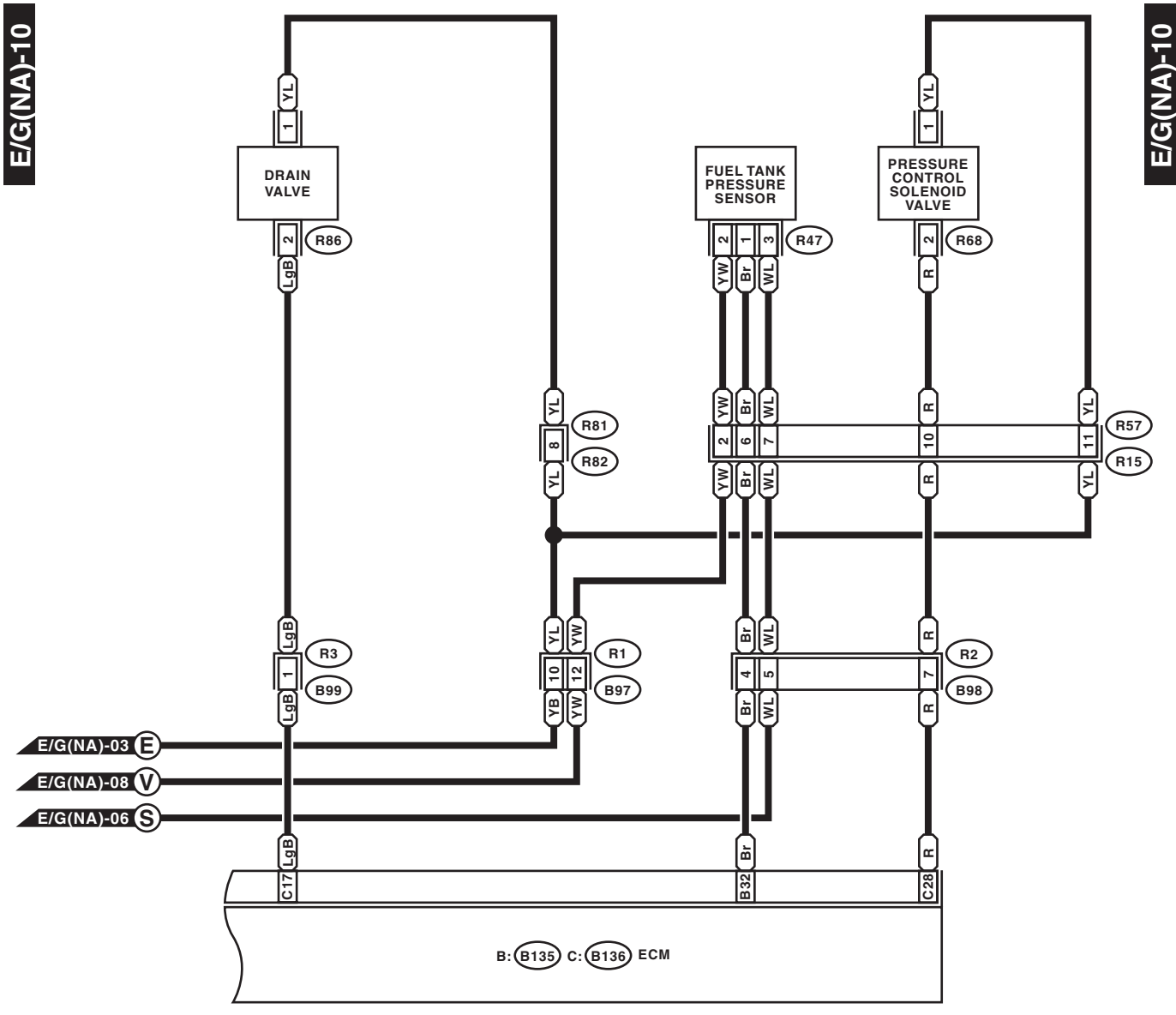

E/G(NA)-10

E/G(NA)-10

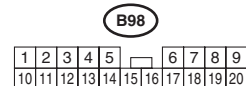
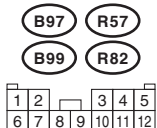
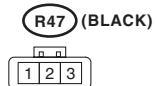

B: B135

1	2	3	4	5	6	7					
8	9	10	11	12	13	14	15	16	17	18	19
20	21	22	23	24	25	26	27				
28	29	30	31	32	33	34	35				

C: B136

1	2	3	4	5	6					
7	8	9	10	11	12	13	14	15	16	
17	18	19	20	21	22	23	24	25	26	27
28	29	30	31	32	33	34	35			

WI-16879

# Engine Electrical System

Brought to you by Eris Studios  
NOT FOR RESALE

## WIRING SYSTEM

### 2. TURBO MODEL

- Transmission serial No. 4078112 or earlier

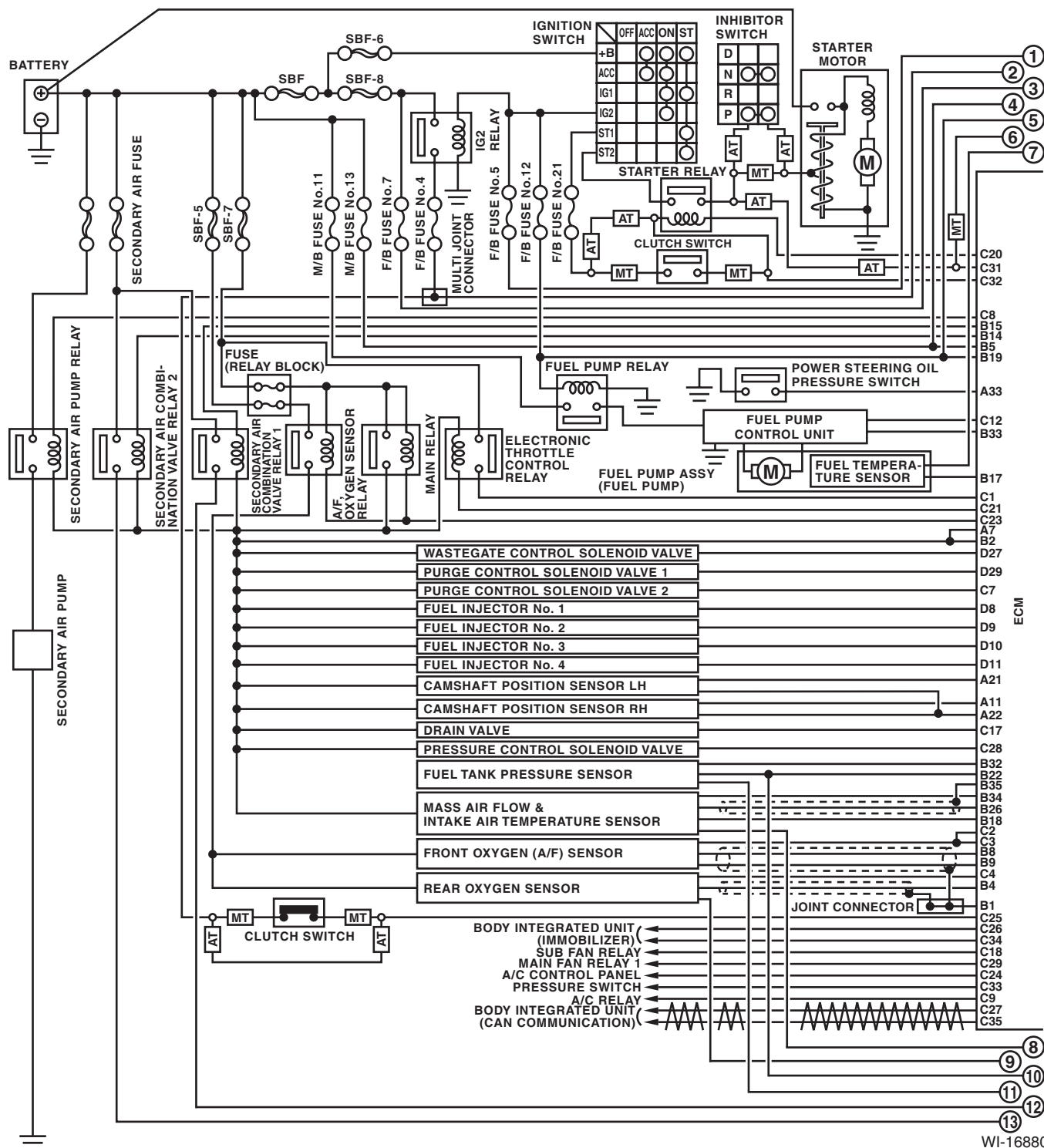

WI-16880

# Engine Electrical System

WIRING SYSTEM

Brought to you by *Chris Studios*  
NOT FOR SALE

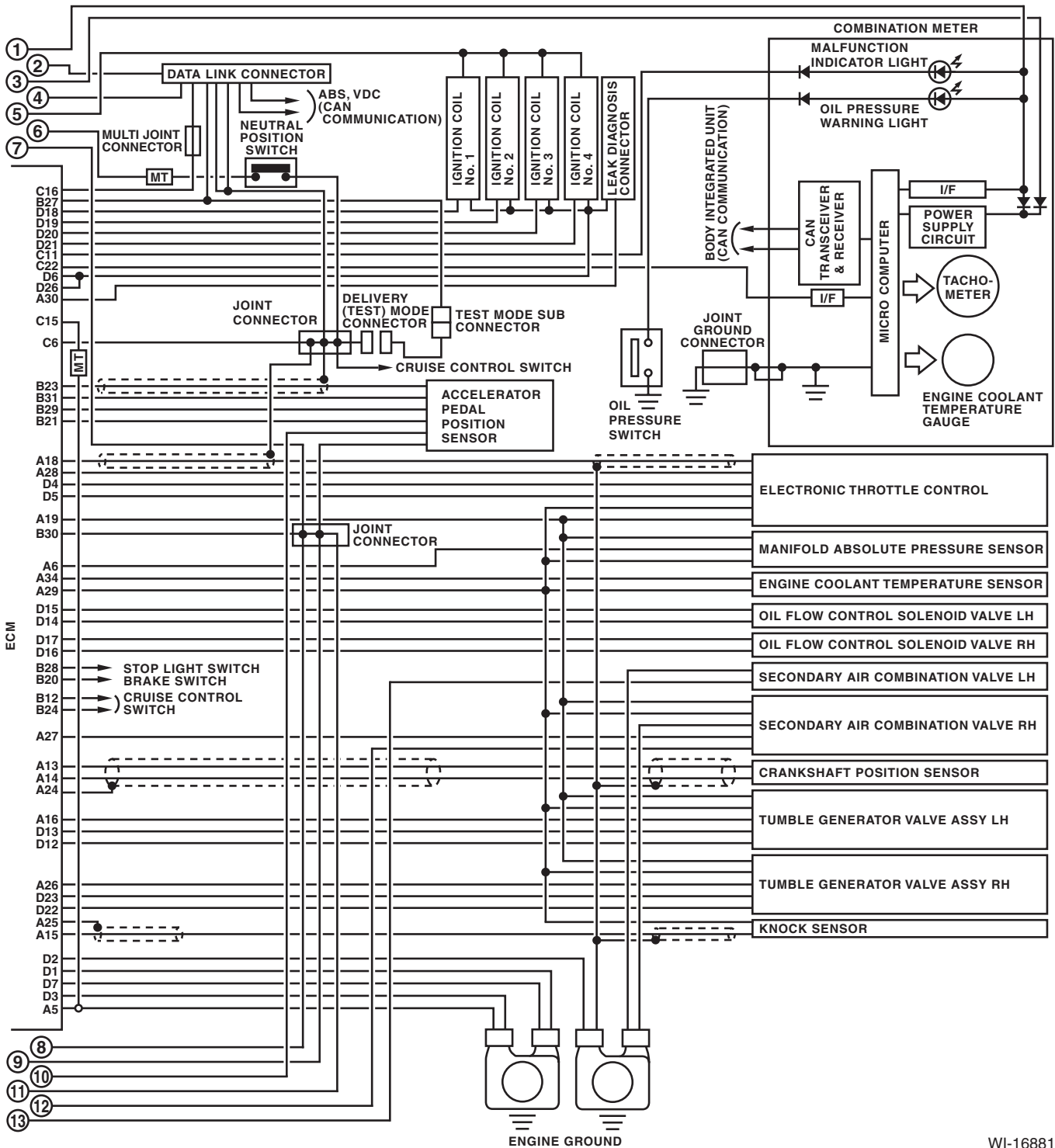

WI-16881

# Engine Electrical System

Brought to you by Eris Studios  
NOT FOR RESALE

## WIRING SYSTEM

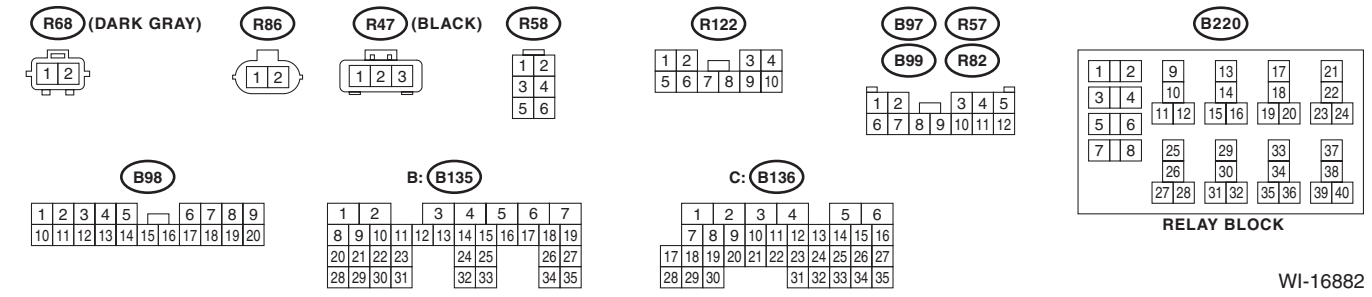
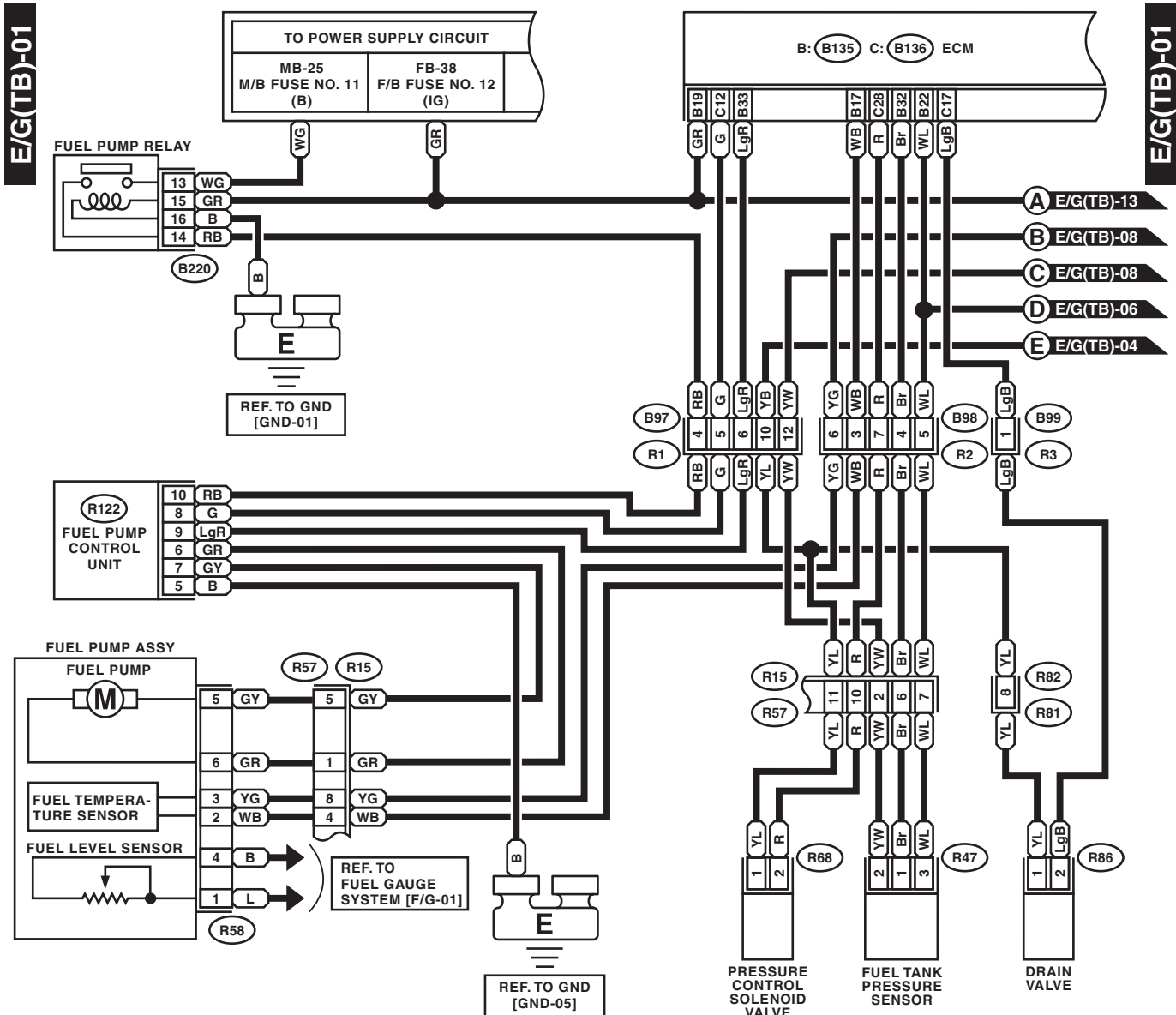

WI-16882

Brought to you by *Chris Studios*  
 NOT FOR SALE

**E/G(TB)-02**

**E/G(TB)-02**

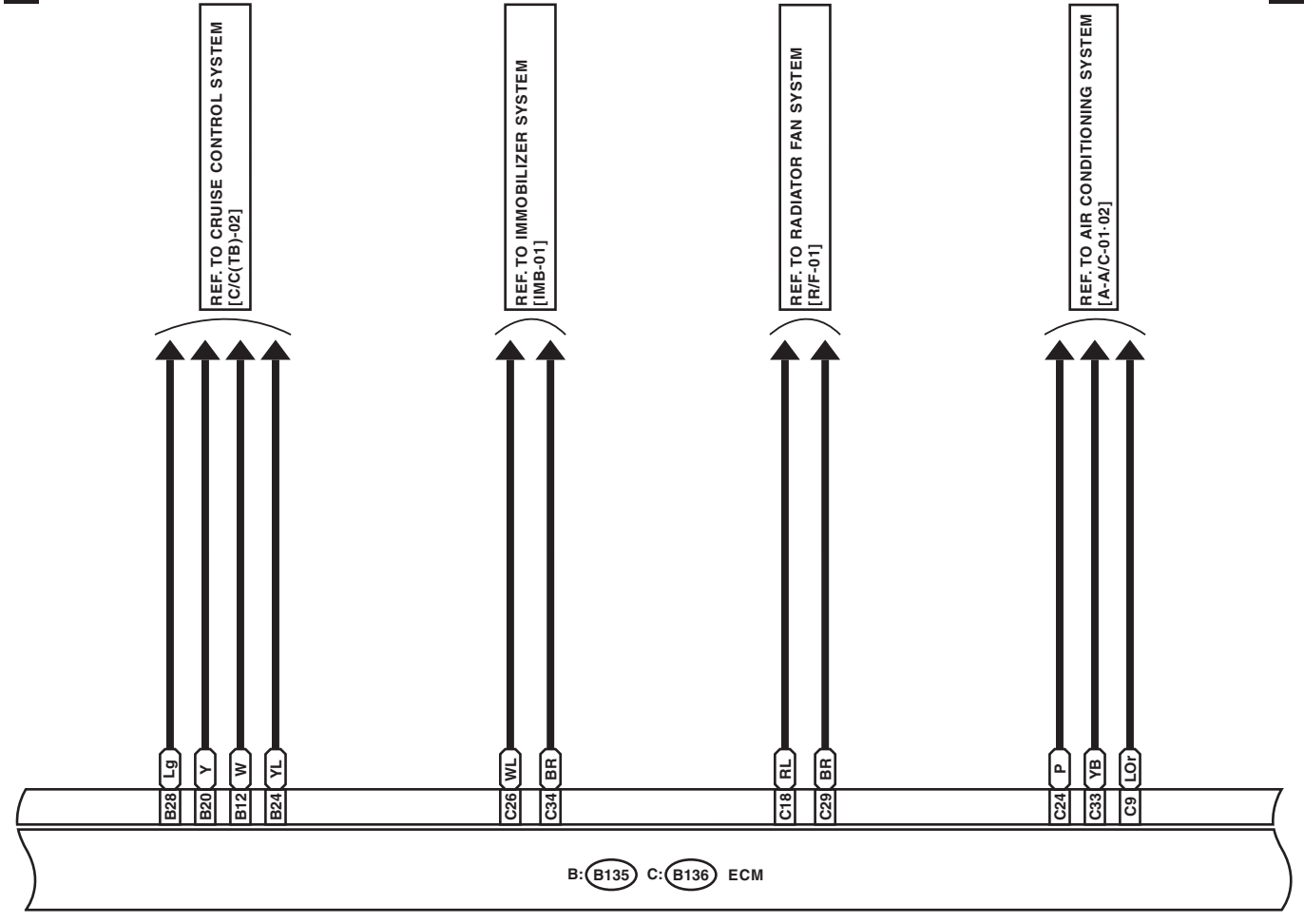

**B: B135**

1	2	3	4	5	6	7					
8	9	10	11	12	13	14	15	16	17	18	19
20	21	22	23	24	25	26	27				
28	29	30	31	32	33	34	35				

**C: B136**

1	2	3	4	5	6					
7	8	9	10	11	12	13	14	15	16	
17	18	19	20	21	22	23	24	25	26	27
28	29	30	31	32	33	34	35			

WI-16883

# Engine Electrical System

Brought to you by Eris Studios  
NOT FOR RESALE

## WIRING SYSTEM

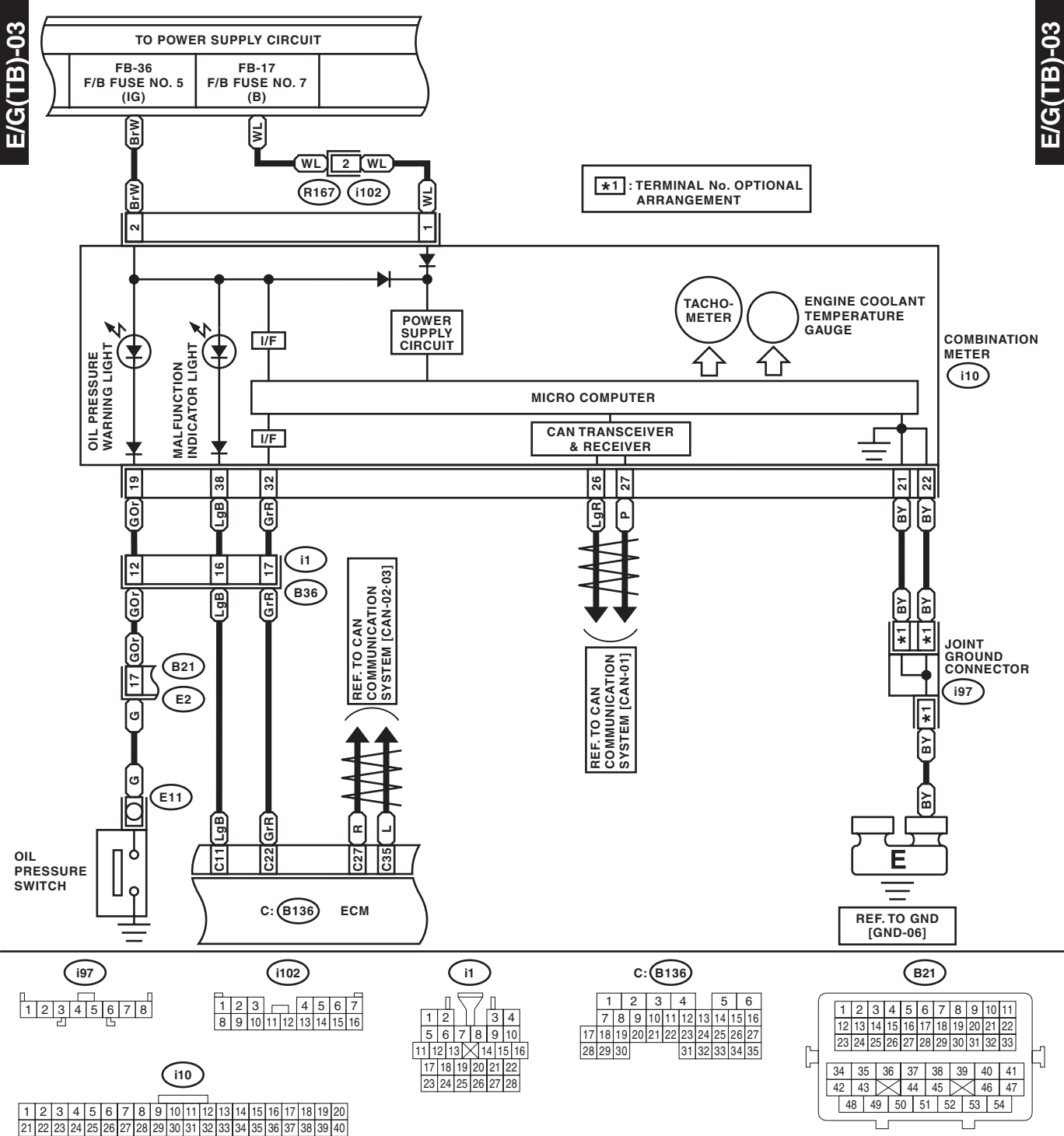

WI-16884

# Engine Electrical System

WIRING SYSTEM

Brought to you by *Chris Studios*  
NO COPY SALE

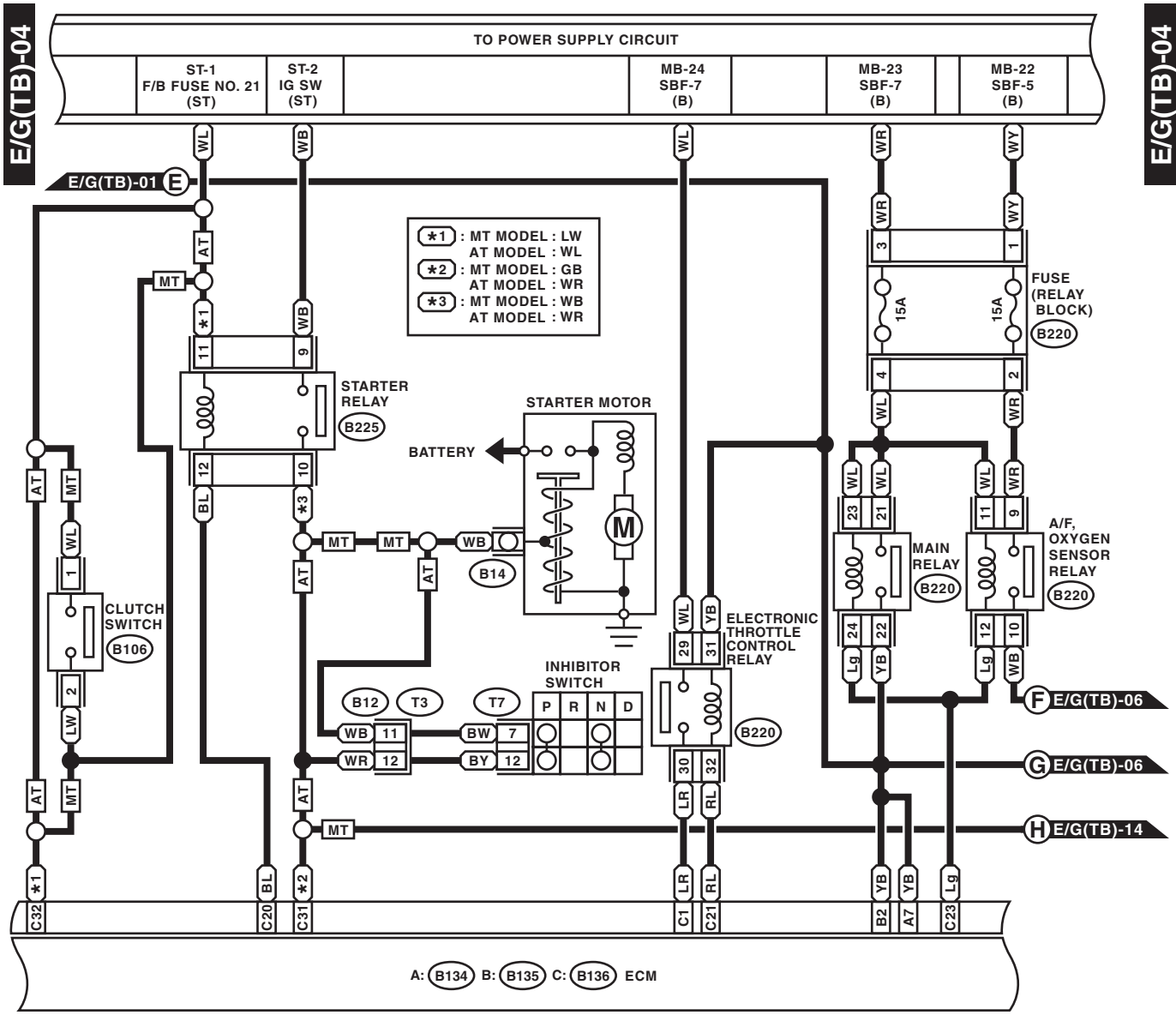

B106

1
2

B12

1	2	3	4
5	6	7	8
9	10	11	12

T7 (BLACK)

1	2	3	4	5	6	7
8	9	10	11	12	13	14
15	16	17	18	19	20	21
22	23	24	25	26	27	28
29	30	31	32	33	34	35

A: B134

1	2	3	4	5	6	7
8	9	10	11	12	13	14
15	16	17	18	19	20	21
22	23	24	25	26	27	28
29	30	31	32	33	34	35

B: B135

1	2	3	4	5	6	7
8	9	10	11	12	13	14
15	16	17	18	19	20	21
22	23	24	25	26	27	28
29	30	31	32	33	34	35

B220

B225

1	2	9	13	17	21
3	4	10	14	18	22
5	6	11	15	19	23
7	8	12	16	20	24
		25	29	33	37
		26	30	34	38
		27	31	32	35
		36	39	40	

RELAY BLOCK

C: B136

1	2	3	4	5	6
7	8	9	10	11	12
13	14	15	16	17	18
19	20	21	22	23	24
25	26	27	28	29	30
31	32	33	34	35	

WI-16885

# Engine Electrical System

Brought to you by Eris Studios  
NOT FOR RESALE

## WIRING SYSTEM

E/G(TB)-05

E/G(TB)-05

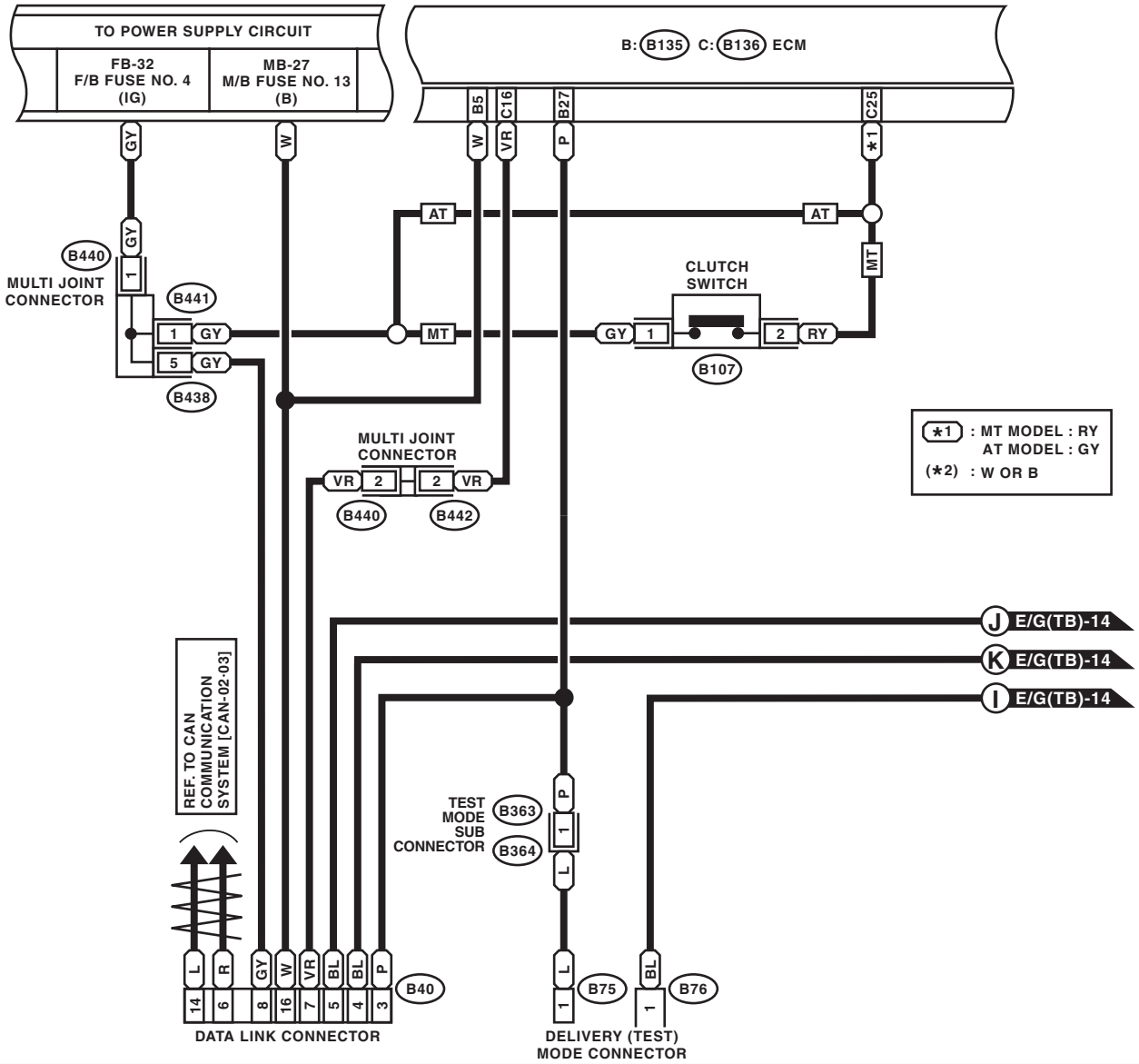

\*1 : MT MODEL : RY  
AT MODEL : GY  
(\*2) : W OR B

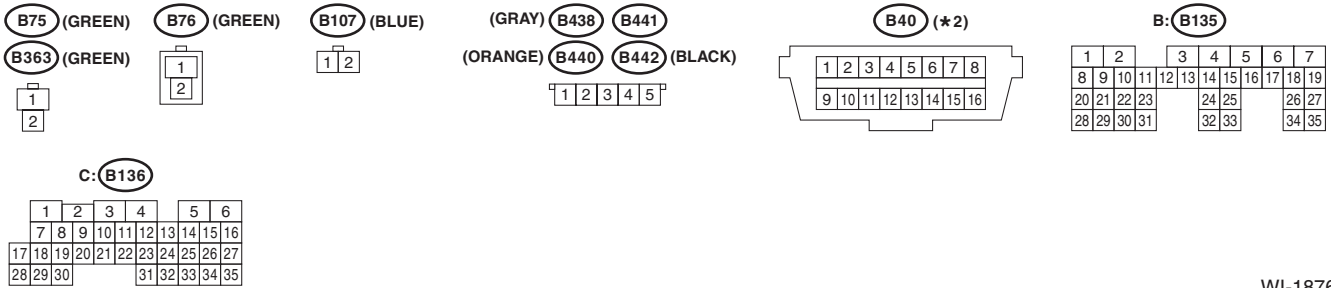

WI-18764



# Engine Electrical System

WIRING SYSTEM

Brought to you by *Chris Studios*  
NOT FOR SALE

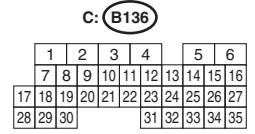
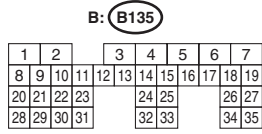
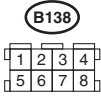
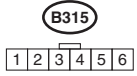
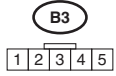
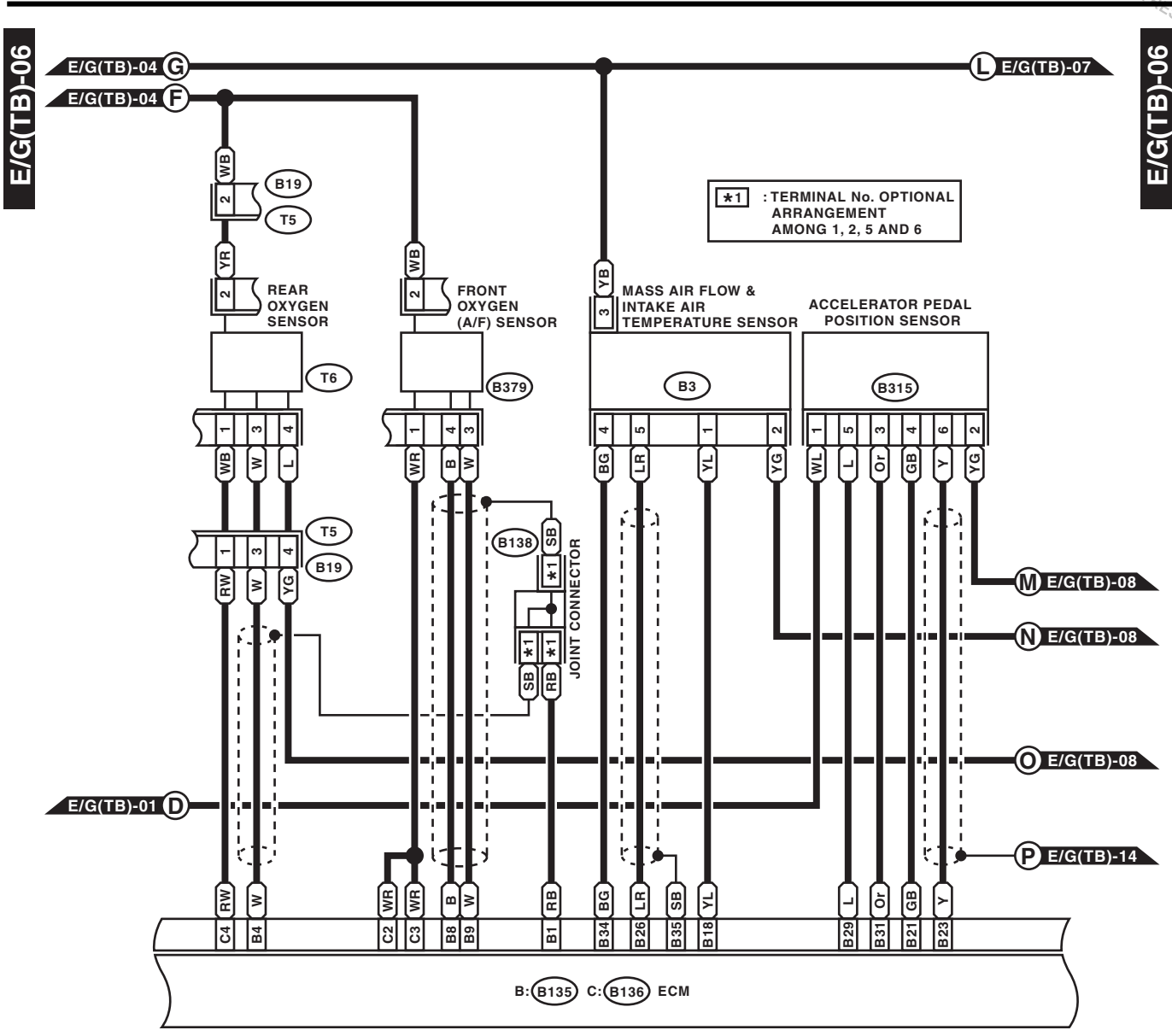

WI-16887

# Engine Electrical System

Brought to you by Eris Studios  
NOT FOR RESALE

WIRING SYSTEM

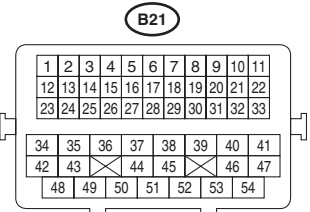
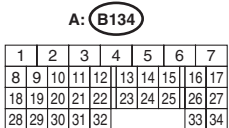
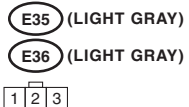
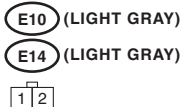
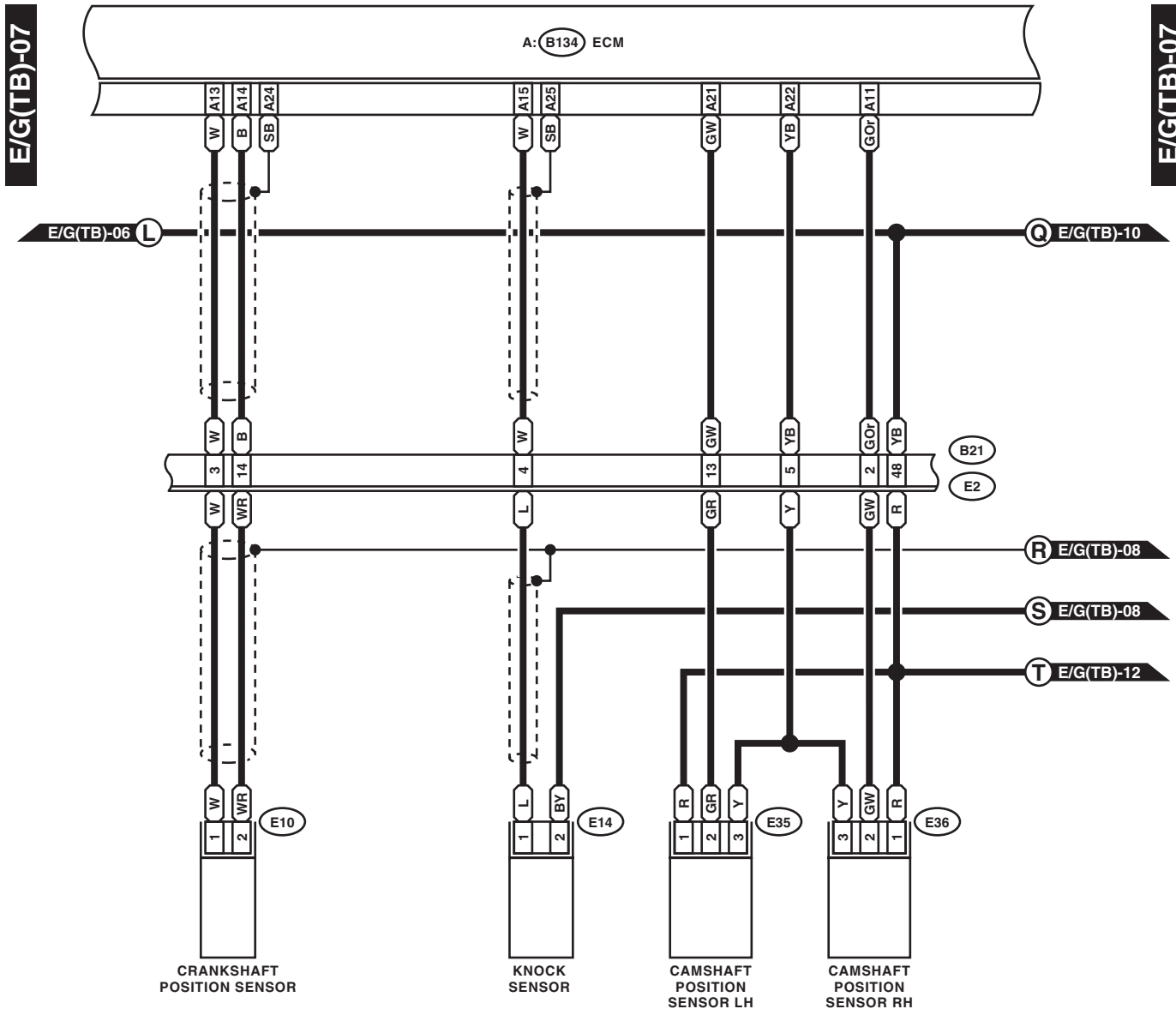

WI-16888

# Engine Electrical System

WIRING SYSTEM

Brought to you by *Chris Studios*  
 NOT FOR SALE

E/G(TB)-08

E/G(TB)-08

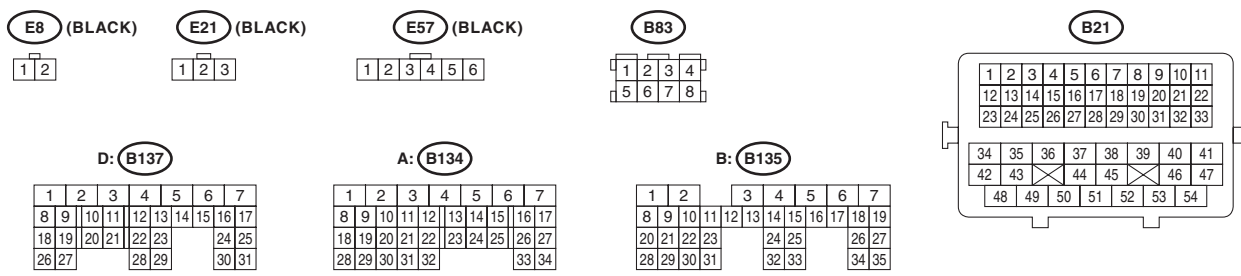
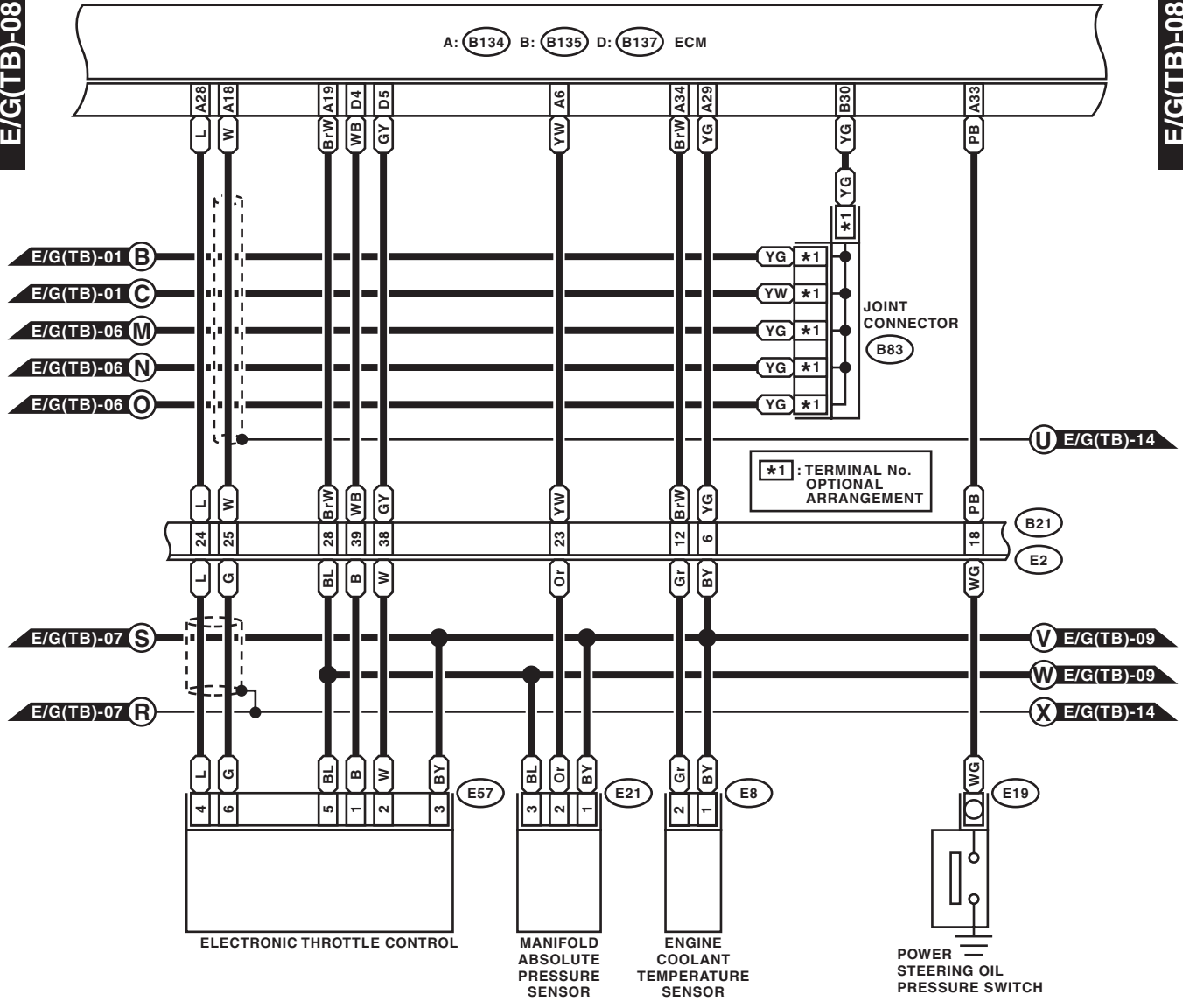

WI-16889

# Engine Electrical System

Brought to you by Eris Studios  
NOT FOR RESALE

WIRING SYSTEM

E/G(TB)-09

E/G(TB)-09

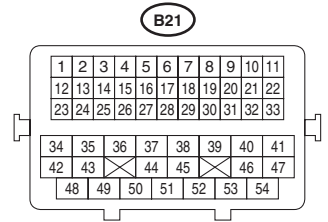
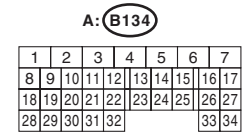
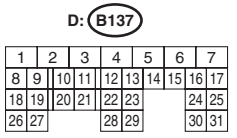
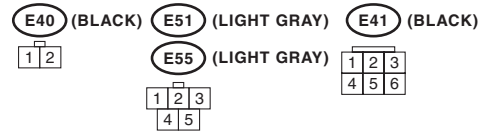
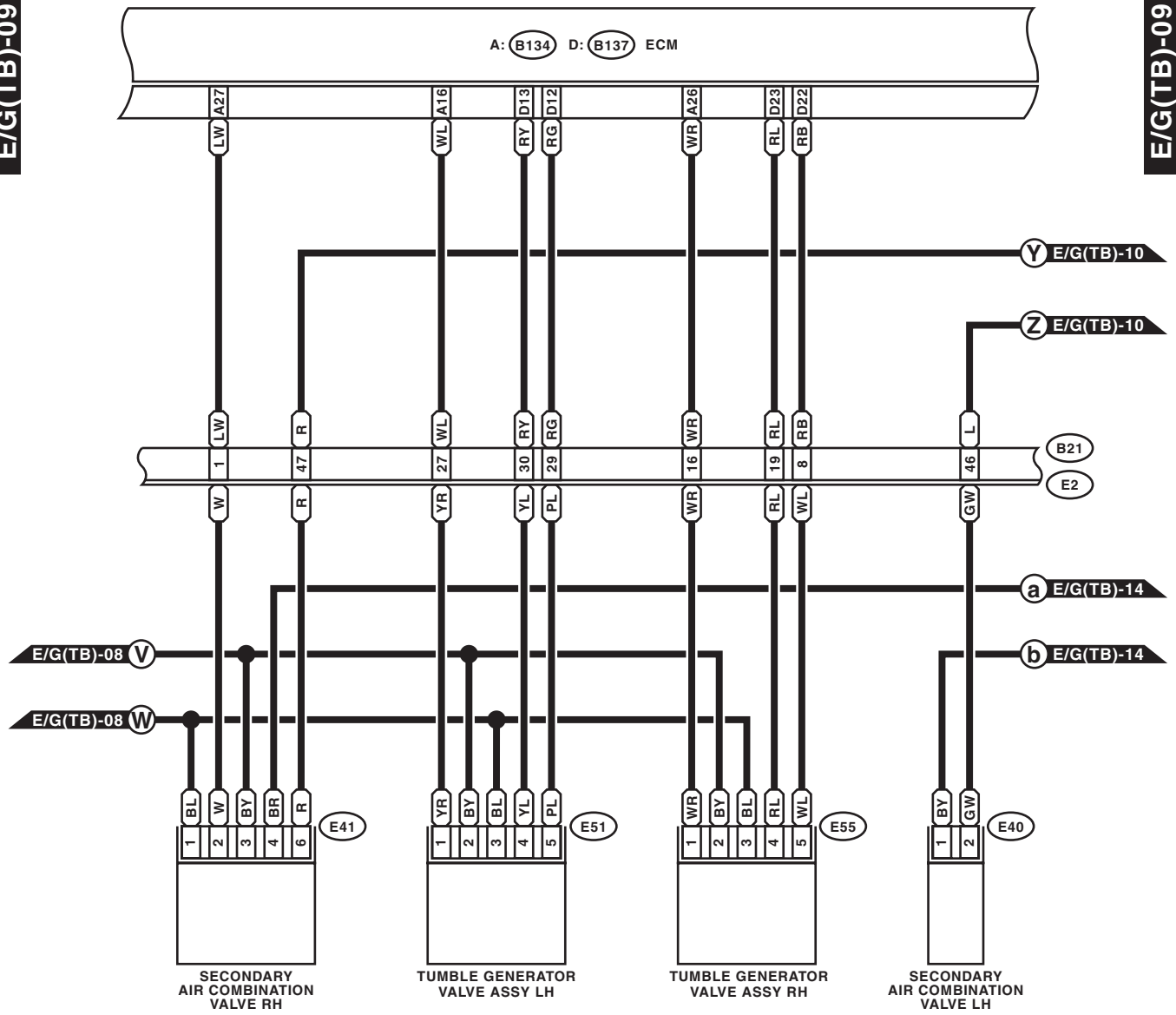

WI-16890

# Engine Electrical System

WIRING SYSTEM

Brought to you by *Chris Studios*  
 NOT FOR SALE

E/G(TB)-10

E/G(TB)-10

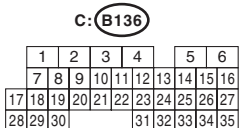
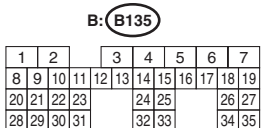
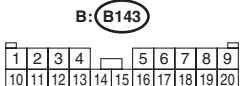
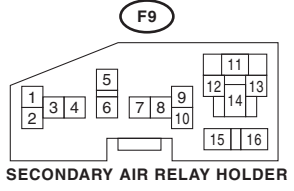
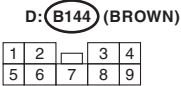
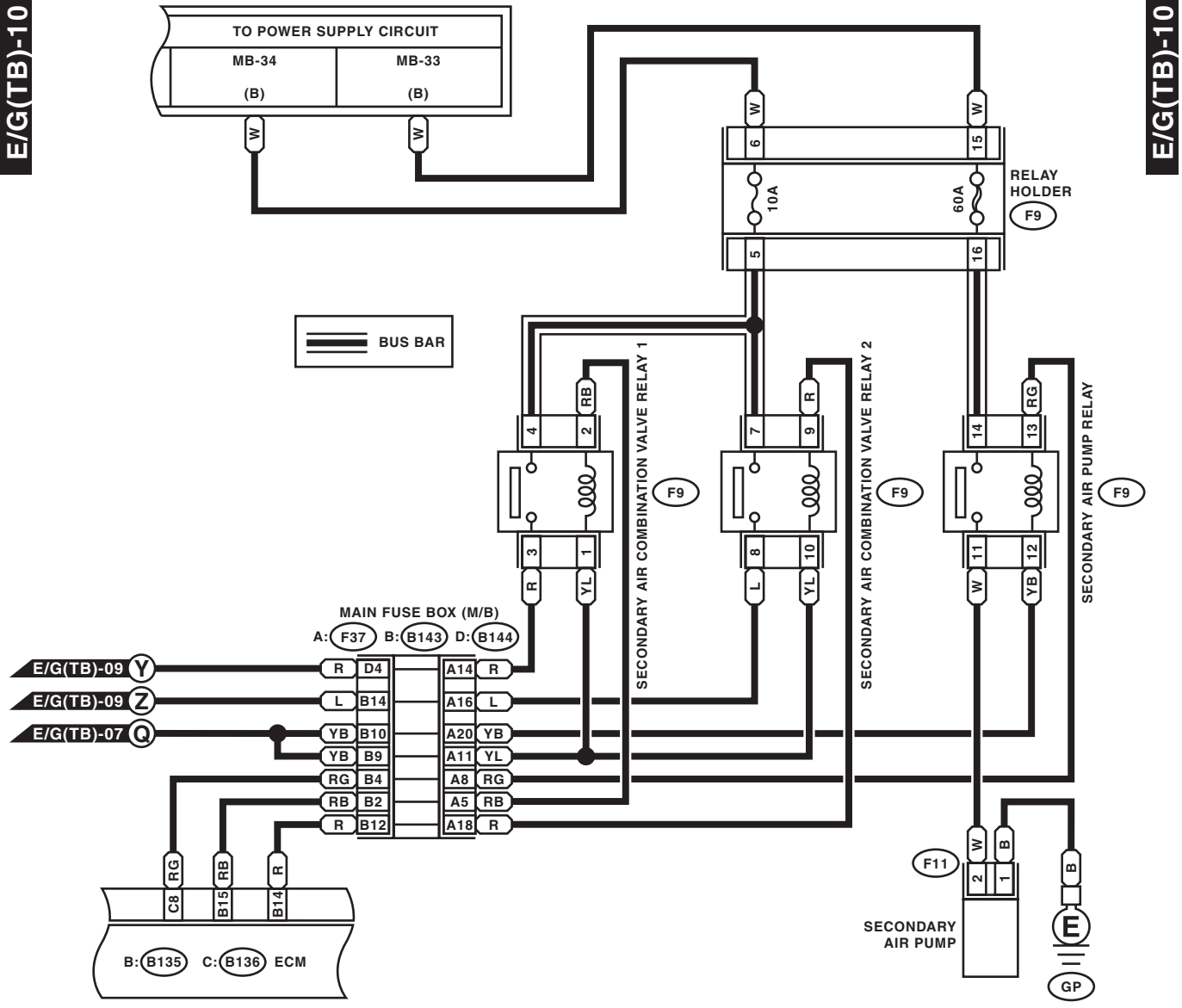

WI-16891

# Engine Electrical System

## WIRING SYSTEM

Brought to you by Eris Studios  
NOT FOR RESALE

E/G(TB)-11

E/G(TB)-11

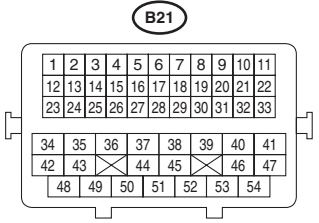
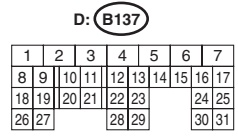
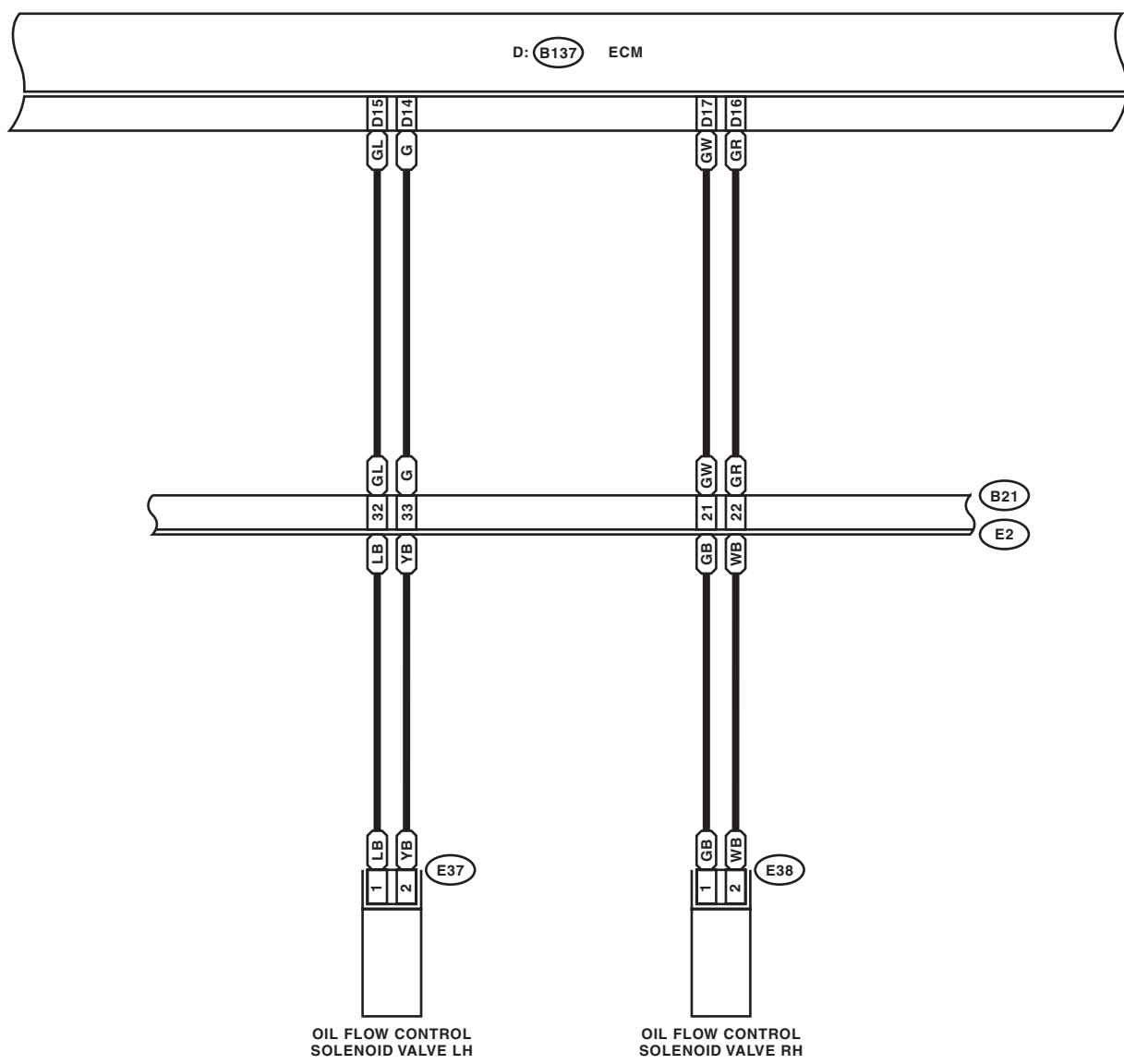

WI-16892

# Engine Electrical System

WIRING SYSTEM

Brought to you by *Chris Studios*  
NOT FOR SALE

E/G(TB)-12

E/G(TB)-12

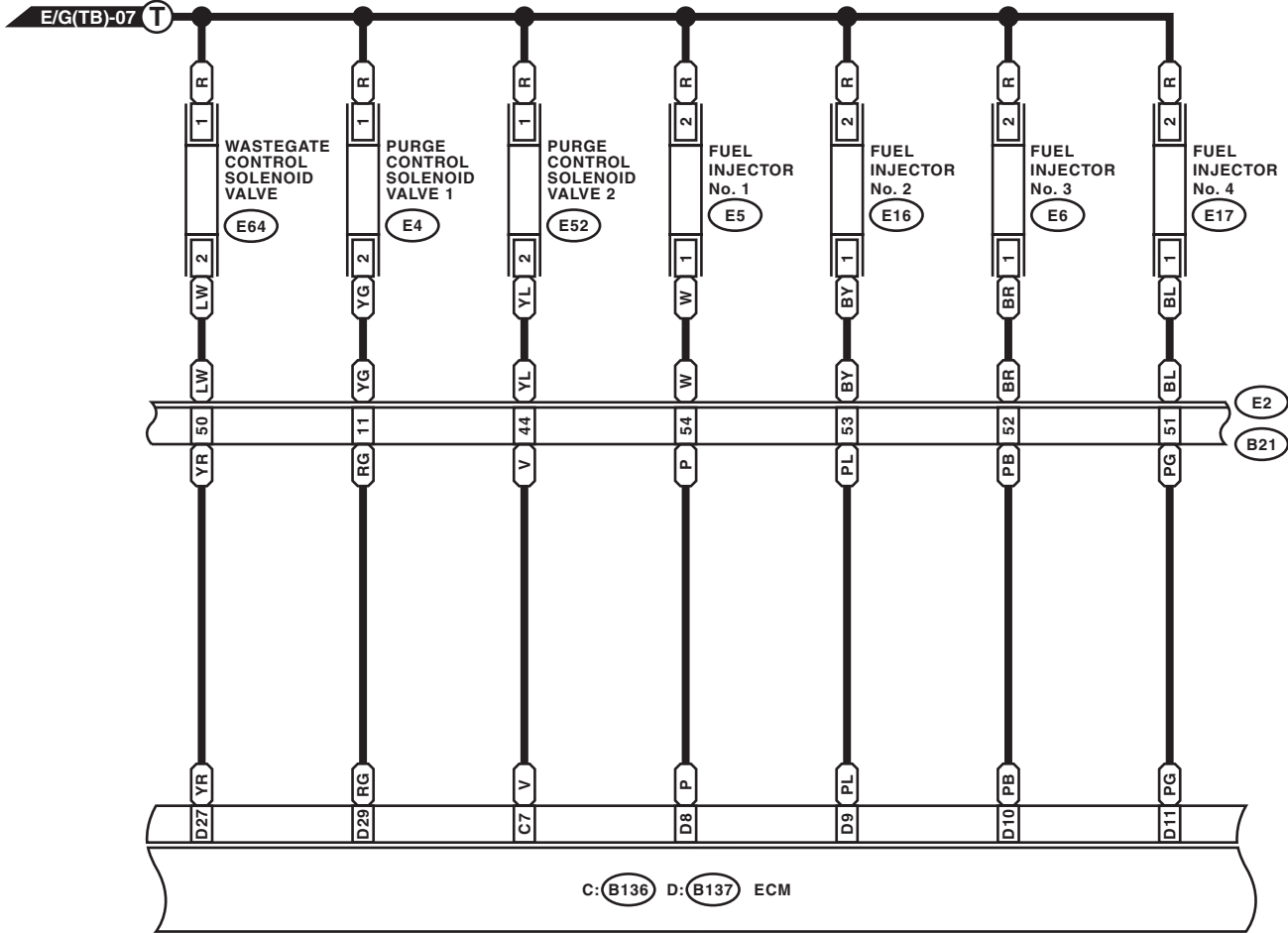

<b>E4</b> (BLACK)	<b>E5</b> (DARK GRAY)	<b>D: (B137)</b>	<b>C: (B136)</b>	<b>B21</b>																																																																																																																																									
<b>E52</b> (BLACK)	<b>E6</b> (DARK GRAY)	<table border="1"> <tr><td>1</td><td>2</td><td>3</td><td>4</td><td>5</td><td>6</td><td>7</td></tr> <tr><td>8</td><td>9</td><td>10</td><td>11</td><td>12</td><td>13</td><td>14</td></tr> <tr><td>15</td><td>16</td><td>17</td><td>24</td><td>25</td><td></td><td></td></tr> <tr><td>18</td><td>19</td><td>20</td><td>21</td><td>22</td><td>23</td><td></td></tr> <tr><td>26</td><td>27</td><td></td><td>28</td><td>29</td><td>30</td><td>31</td></tr> </table>	1	2	3	4	5	6	7	8	9	10	11	12	13	14	15	16	17	24	25			18	19	20	21	22	23		26	27		28	29	30	31	<table border="1"> <tr><td>1</td><td>2</td><td>3</td><td>4</td><td>5</td><td>6</td></tr> <tr><td>7</td><td>8</td><td>9</td><td>10</td><td>11</td><td>12</td></tr> <tr><td>13</td><td>14</td><td>15</td><td>16</td><td>17</td><td>18</td></tr> <tr><td>19</td><td>20</td><td>21</td><td>22</td><td>23</td><td>24</td></tr> <tr><td>25</td><td>26</td><td>27</td><td>28</td><td>29</td><td>30</td></tr> <tr><td>31</td><td>32</td><td>33</td><td>34</td><td>35</td><td></td></tr> </table>	1	2	3	4	5	6	7	8	9	10	11	12	13	14	15	16	17	18	19	20	21	22	23	24	25	26	27	28	29	30	31	32	33	34	35		<table border="1"> <tr><td>1</td><td>2</td><td>3</td><td>4</td><td>5</td><td>6</td><td>7</td><td>8</td><td>9</td><td>10</td><td>11</td></tr> <tr><td>12</td><td>13</td><td>14</td><td>15</td><td>16</td><td>17</td><td>18</td><td>19</td><td>20</td><td>21</td><td>22</td></tr> <tr><td>23</td><td>24</td><td>25</td><td>26</td><td>27</td><td>28</td><td>29</td><td>30</td><td>31</td><td>32</td><td>33</td></tr> <tr><td>34</td><td>35</td><td>36</td><td>37</td><td>38</td><td>39</td><td>40</td><td>41</td><td></td><td></td><td></td></tr> <tr><td>42</td><td>43</td><td>44</td><td>45</td><td>46</td><td>47</td><td></td><td></td><td></td><td></td><td></td></tr> <tr><td>48</td><td>49</td><td>50</td><td>51</td><td>52</td><td>53</td><td>54</td><td></td><td></td><td></td><td></td></tr> </table>	1	2	3	4	5	6	7	8	9	10	11	12	13	14	15	16	17	18	19	20	21	22	23	24	25	26	27	28	29	30	31	32	33	34	35	36	37	38	39	40	41				42	43	44	45	46	47						48	49	50	51	52	53	54				
1	2	3	4	5	6	7																																																																																																																																							
8	9	10	11	12	13	14																																																																																																																																							
15	16	17	24	25																																																																																																																																									
18	19	20	21	22	23																																																																																																																																								
26	27		28	29	30	31																																																																																																																																							
1	2	3	4	5	6																																																																																																																																								
7	8	9	10	11	12																																																																																																																																								
13	14	15	16	17	18																																																																																																																																								
19	20	21	22	23	24																																																																																																																																								
25	26	27	28	29	30																																																																																																																																								
31	32	33	34	35																																																																																																																																									
1	2	3	4	5	6	7	8	9	10	11																																																																																																																																			
12	13	14	15	16	17	18	19	20	21	22																																																																																																																																			
23	24	25	26	27	28	29	30	31	32	33																																																																																																																																			
34	35	36	37	38	39	40	41																																																																																																																																						
42	43	44	45	46	47																																																																																																																																								
48	49	50	51	52	53	54																																																																																																																																							
<b>E64</b> (BLUE)	<b>E16</b> (DARK GRAY)																																																																																																																																												
<b>E17</b> (DARK GRAY)																																																																																																																																													

WI-16893

# Engine Electrical System

Brought to you by Eris Studios  
NOT FOR RESALE

WIRING SYSTEM

E/G(TB)-13

E/G(TB)-13

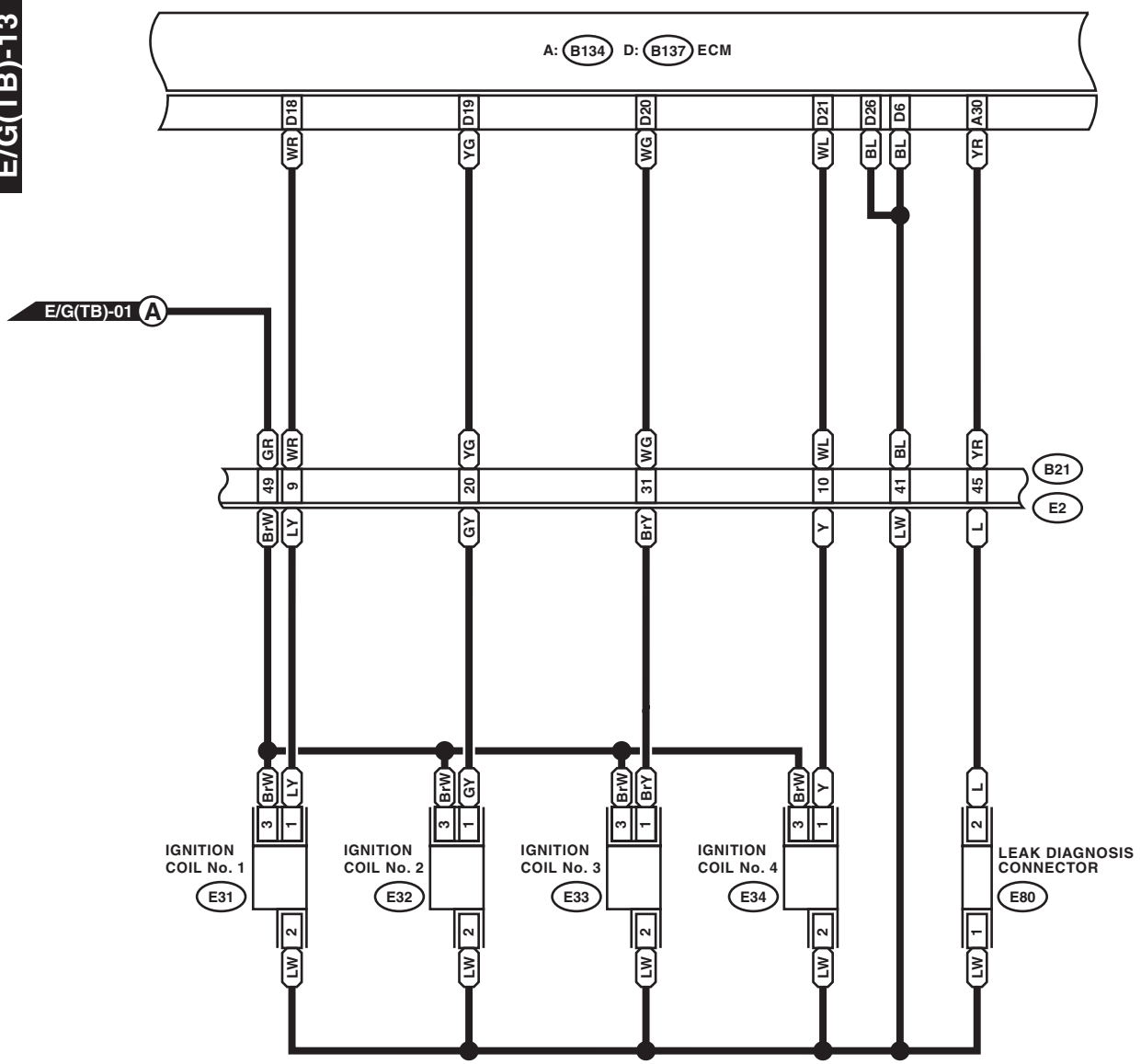

**E80 (DARK GRAY)**

1	2
---	---

**E31 E33 (BLACK)**

1	2	3
---	---	---

**E32 E34 (BLACK)**

1	2	3
---	---	---

**D: B137**

1	2	3	4	5	6	7			
8	9	10	11	12	13	14	15	16	17
18	19	20	21	22	23	24	25	26	27
28	29	30	31	32	33	34			

**A: B134**

1	2	3	4	5	6	7			
8	9	10	11	12	13	14	15	16	17
18	19	20	21	22	23	24	25	26	27
28	29	30	31	32	33	34			

**B21**

1	2	3	4	5	6	7	8	9	10	11
12	13	14	15	16	17	18	19	20	21	22
23	24	25	26	27	28	29	30	31	32	33
34	35	36	37	38	39	40	41			
42	43	44	45	46	47					
48	49	50	51	52	53	54				

WI-16894



# Engine Electrical System

## WIRING SYSTEM

Brought to you by *Chris Studios*  
NOT FOR SALE

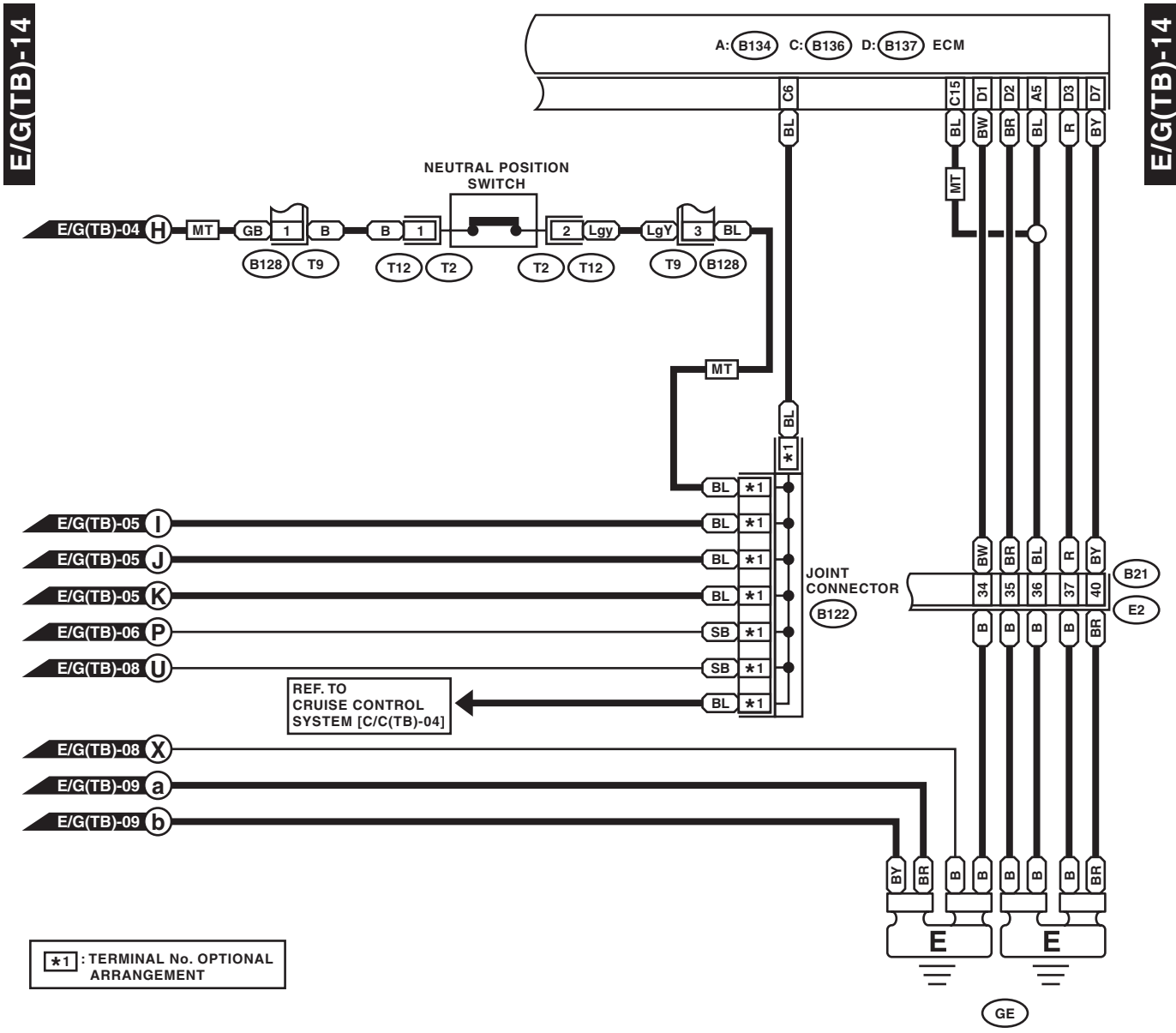

\*1 : TERMINAL No. OPTIONAL ARRANGEMENT

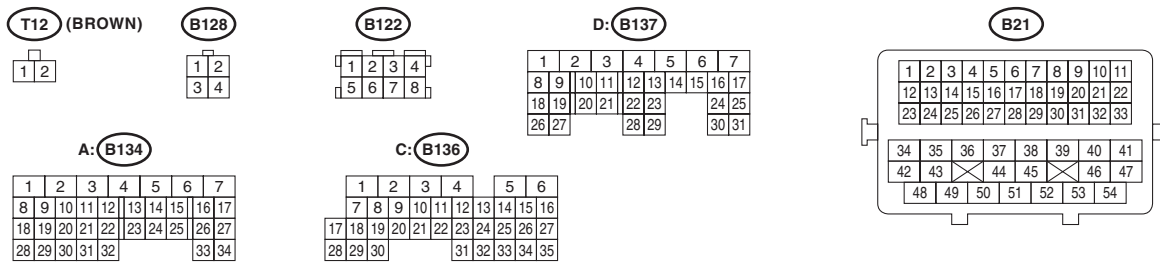

WI-16895

# Engine Electrical System

Brought to you by Eris Studios  
NOT FOR RESALE

## WIRING SYSTEM

- Transmission serial No. 4078113 or later

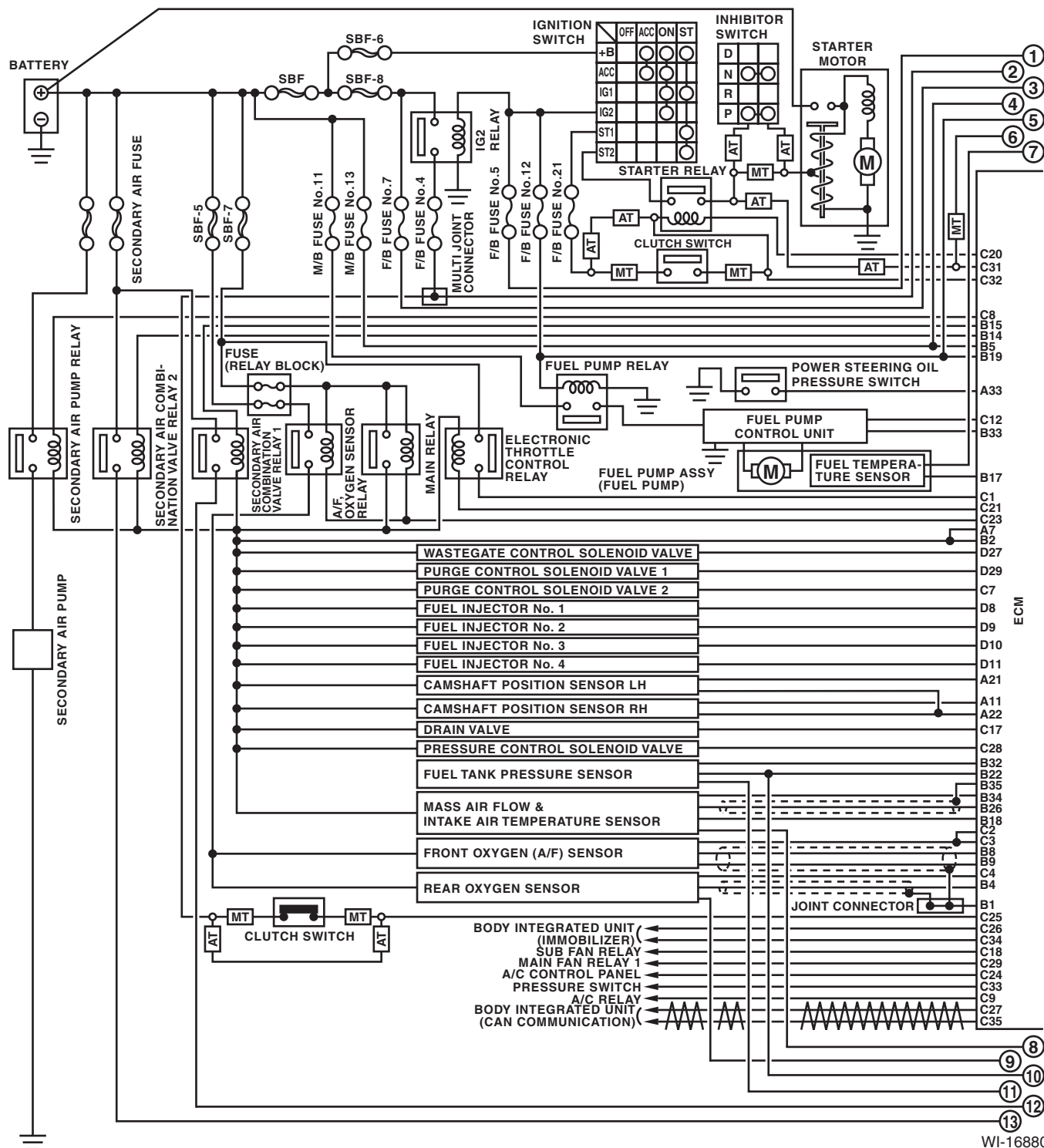

WI-16880

# Engine Electrical System

WIRING SYSTEM

Brought to you by *Chris Studios*  
 NOT FOR SALE

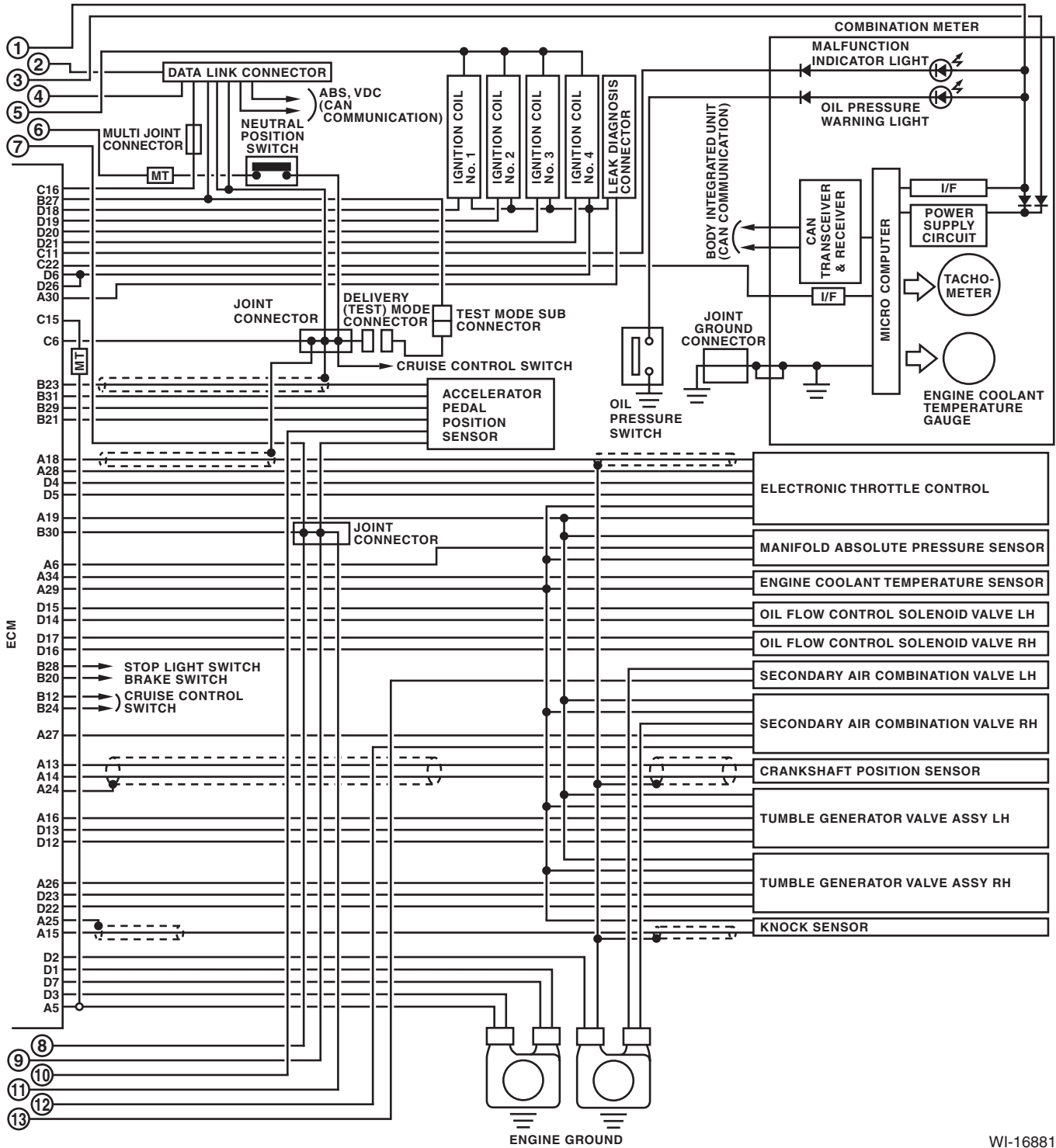

WI-16881

# Engine Electrical System

Brought to you by Eris Studios  
NOT FOR RESALE

## WIRING SYSTEM

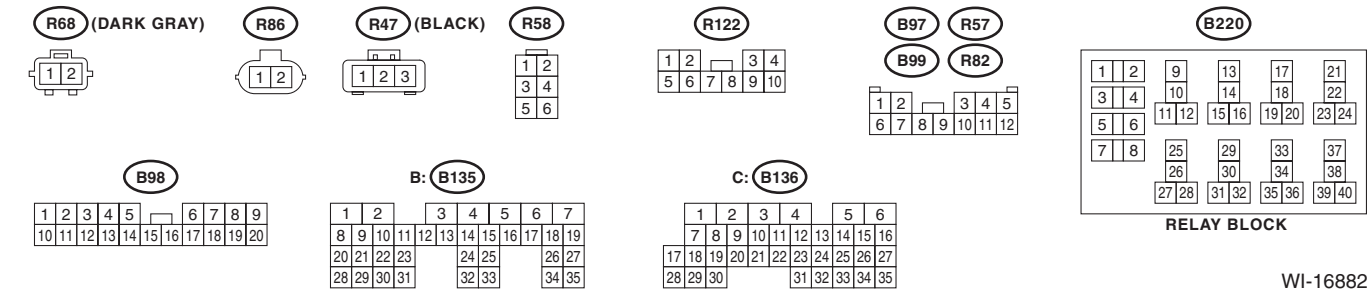
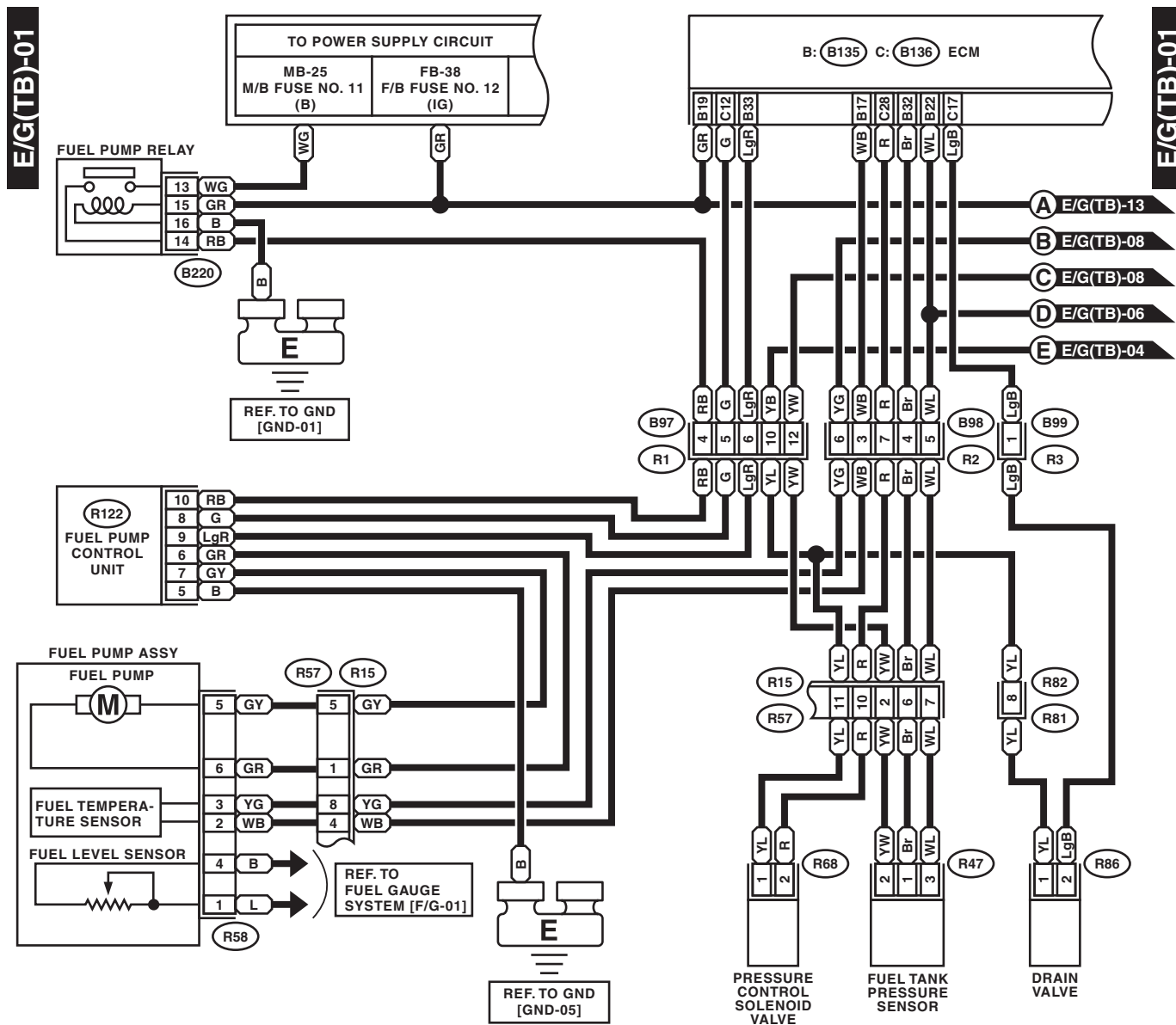

WI-16882

Brought to you by *Chris Studios*  
 NOT FOR SALE

E/G(TB)-02

E/G(TB)-02

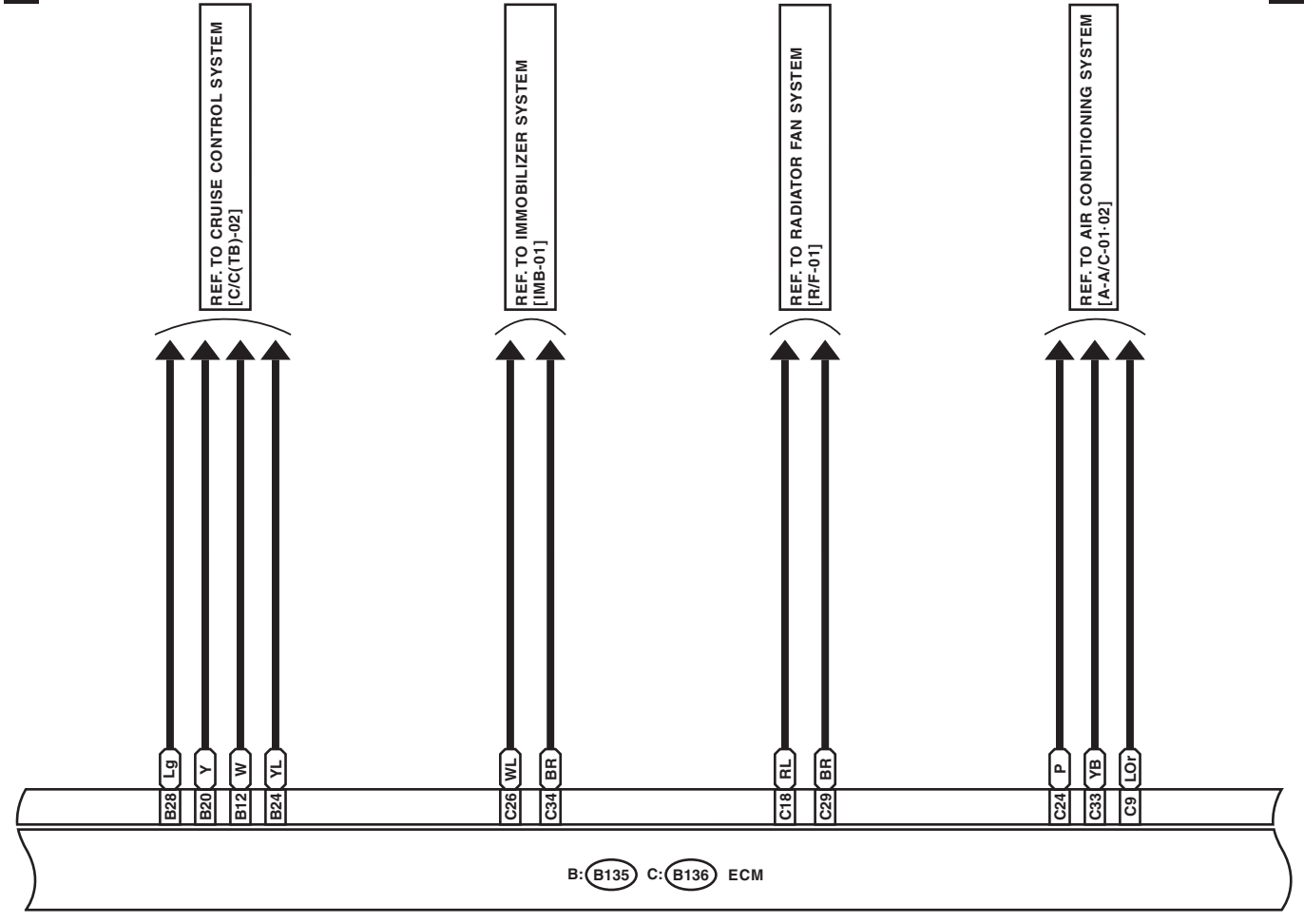

B: **B135**

1	2	3	4	5	6	7					
8	9	10	11	12	13	14	15	16	17	18	19
20	21	22	23	24	25	26	27				
28	29	30	31	32	33	34	35				

C: **B136**

1	2	3	4	5	6					
7	8	9	10	11	12	13	14	15	16	
17	18	19	20	21	22	23	24	25	26	27
28	29	30	31	32	33	34	35			

WI-16883

# Engine Electrical System

Brought to you by Eris Studios  
NOT FOR RESALE

## WIRING SYSTEM

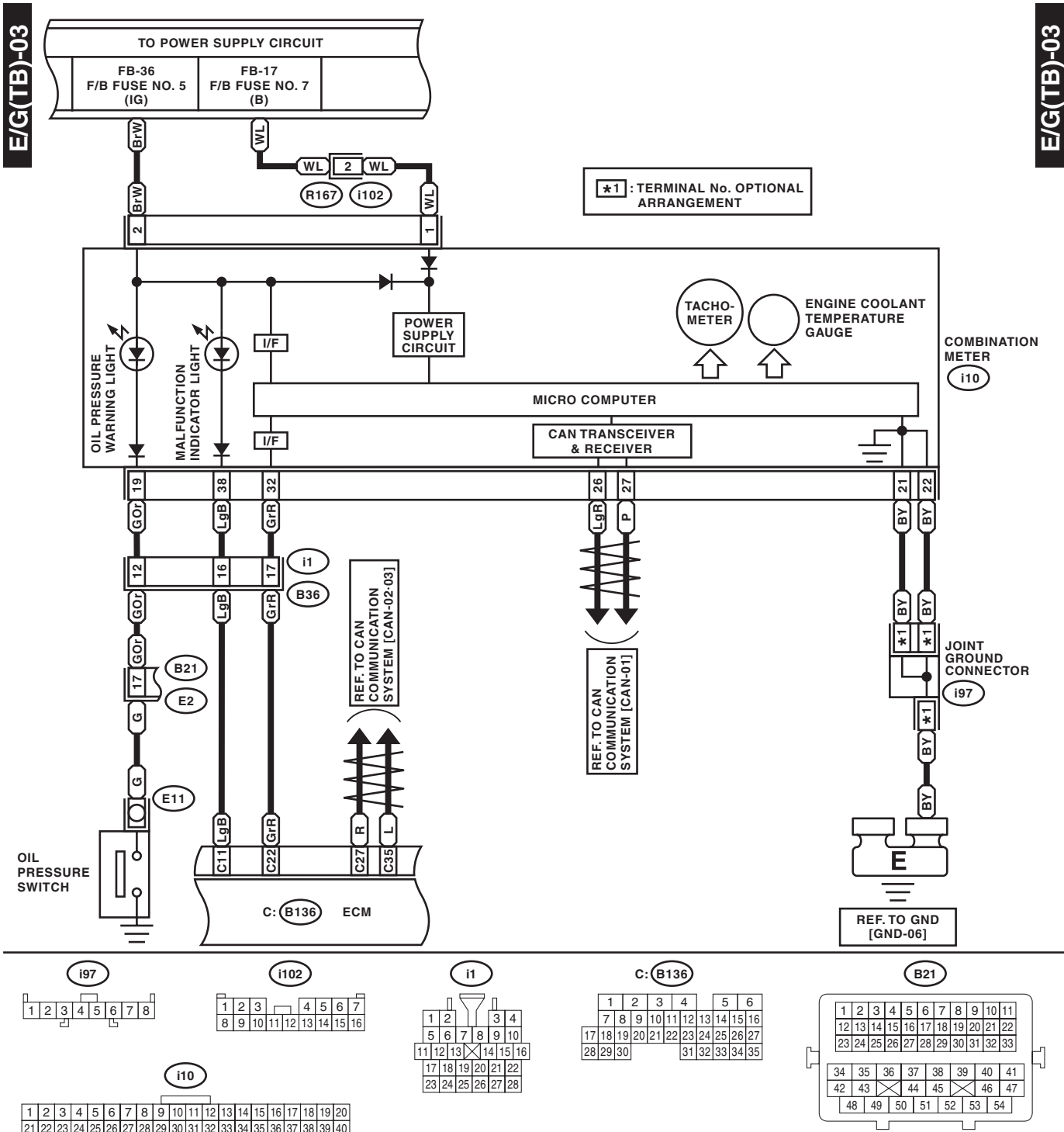

WI-16884

# Engine Electrical System

WIRING SYSTEM

Brought to you by *Chris Studios*  
NO COPYRIGHT SALE

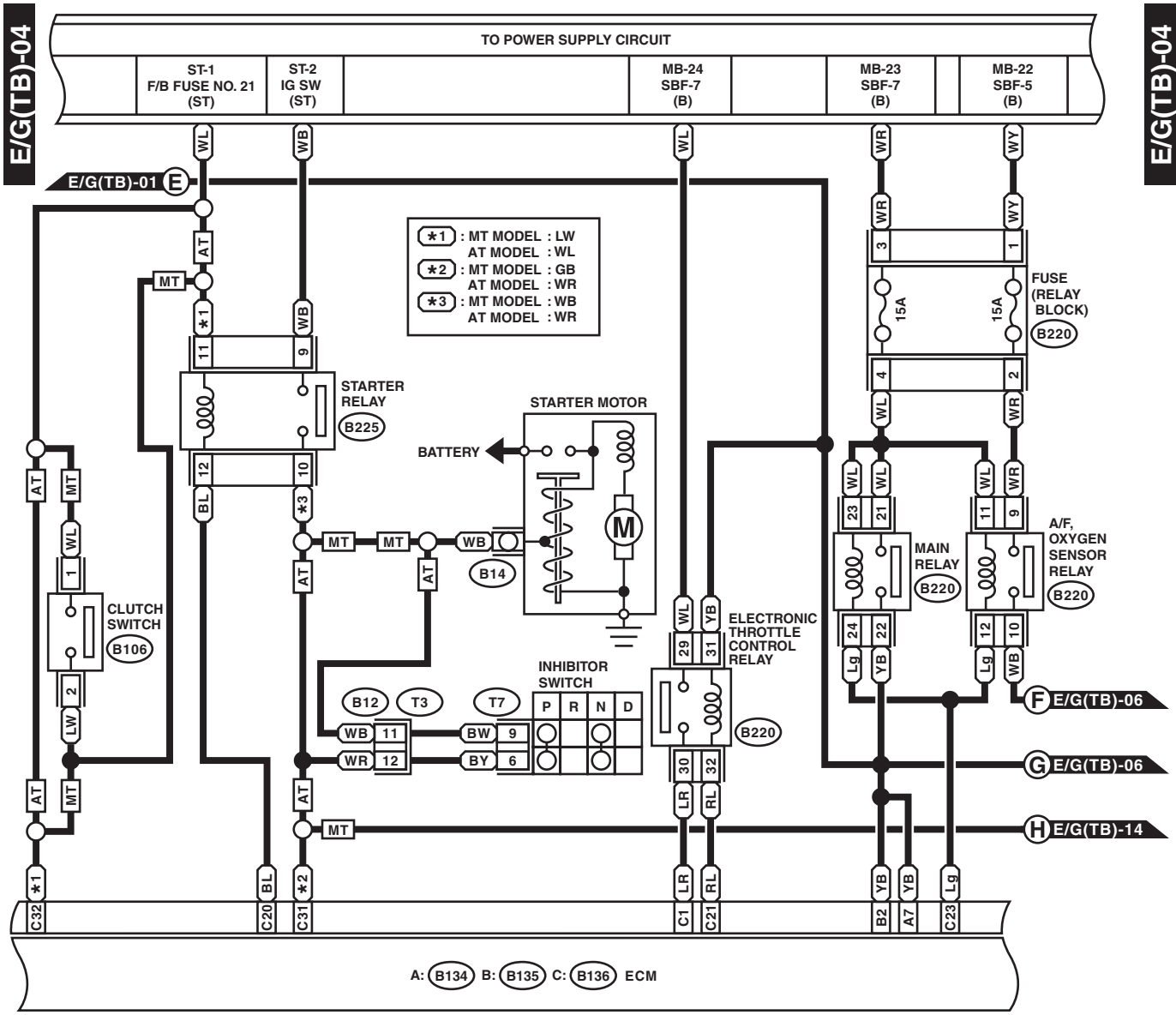

B106



B12



T7 (BLACK)

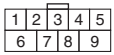

A: B134

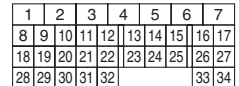

B: B135

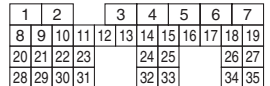

B220

B225

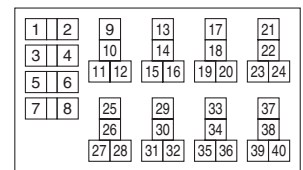

RELAY BLOCK

C: B136

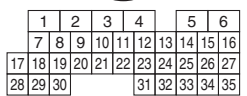

WI-21042

# Engine Electrical System

Brought to you by Eris Studios  
NOT FOR RESALE

## WIRING SYSTEM

E/G(TB)-05

E/G(TB)-05

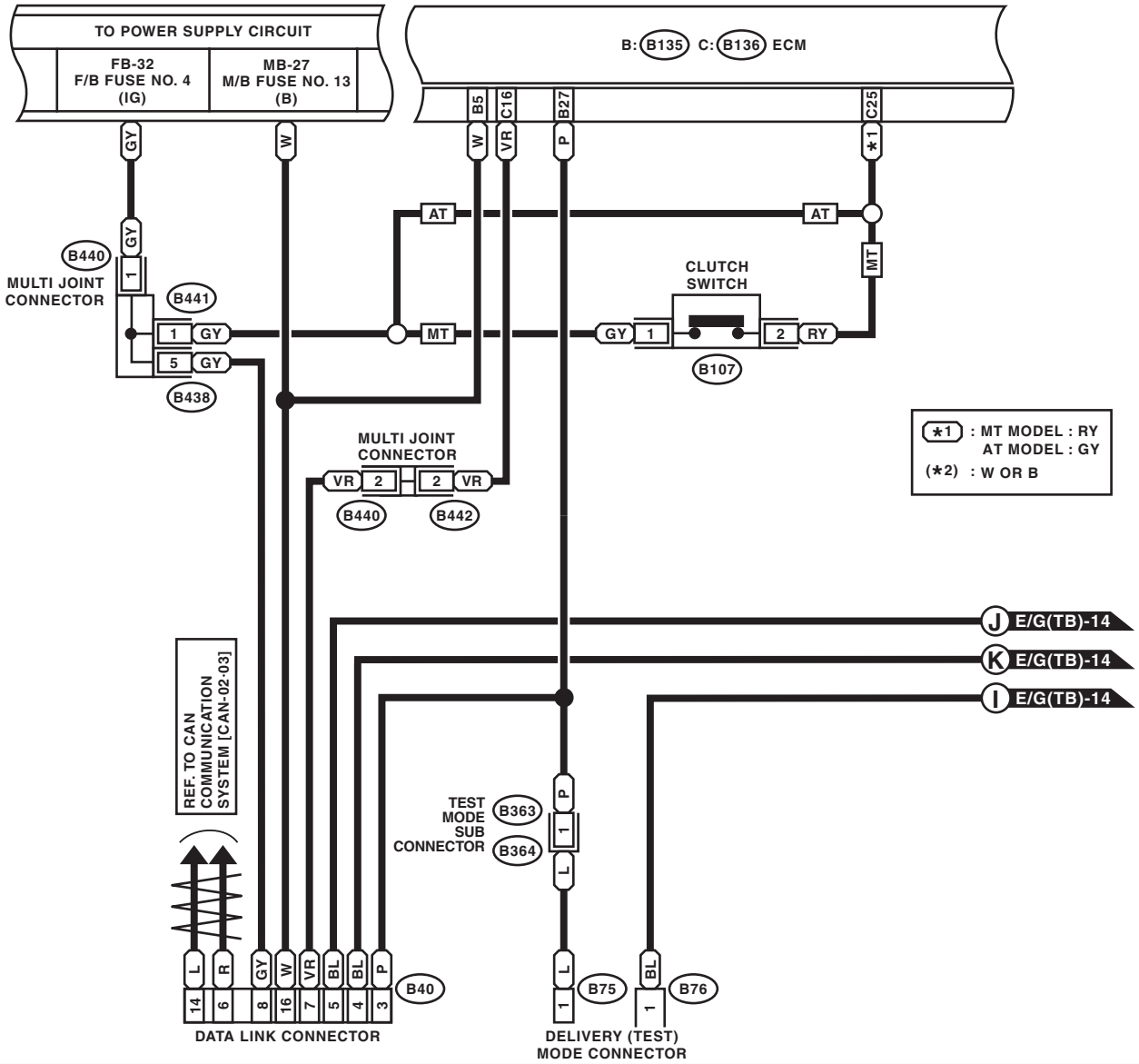

(B75) (GREEN)

(B76) (GREEN)

(B107) (BLUE)

(GRAY) (B438) (B441)  
(ORANGE) (B440) (B442) (BLACK)

(B40) (\*2)

B: (B135)

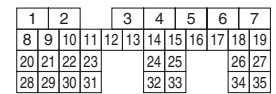
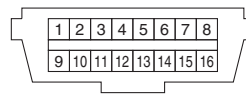
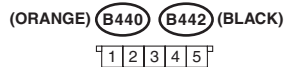
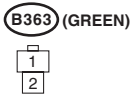

C: (B136)

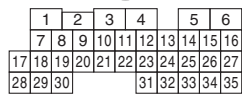

WI-18764



# Engine Electrical System

WIRING SYSTEM

Brought to you by *Chris Studios*  
NOT FOR SALE

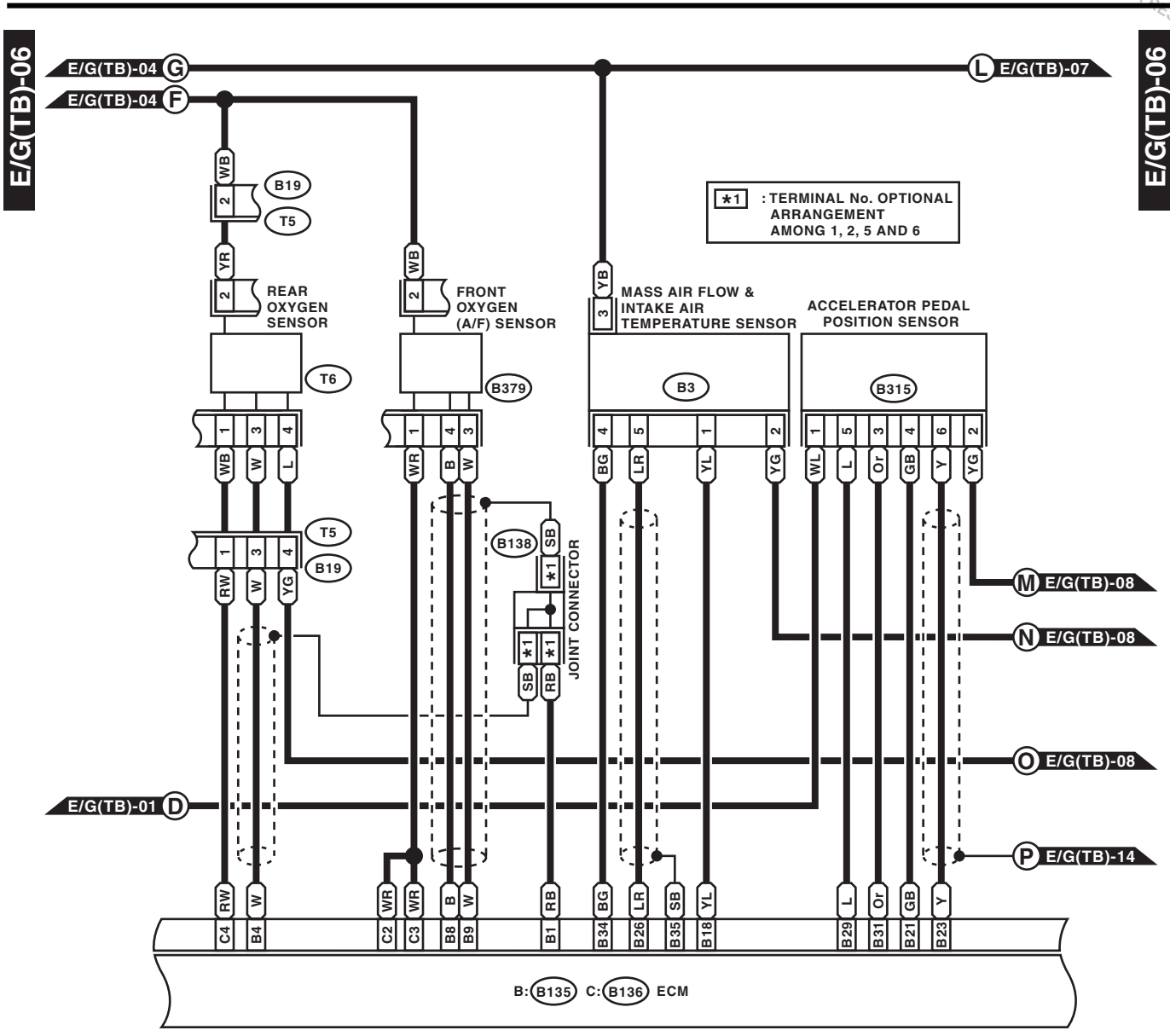

\*1 : TERMINAL No. OPTIONAL ARRANGEMENT AMONG 1, 2, 5 AND 6

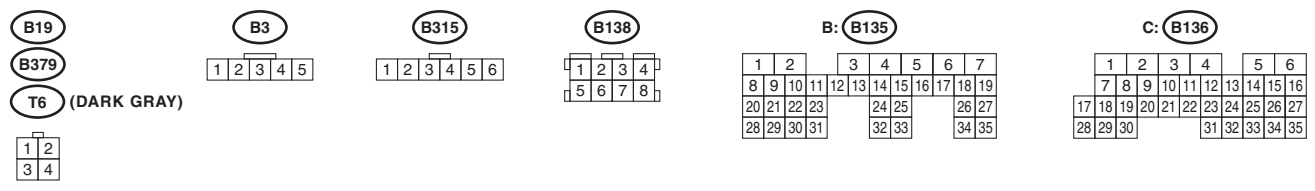

WI-16887

# Engine Electrical System

Brought to you by Eris Studios  
NOT FOR RESALE

WIRING SYSTEM

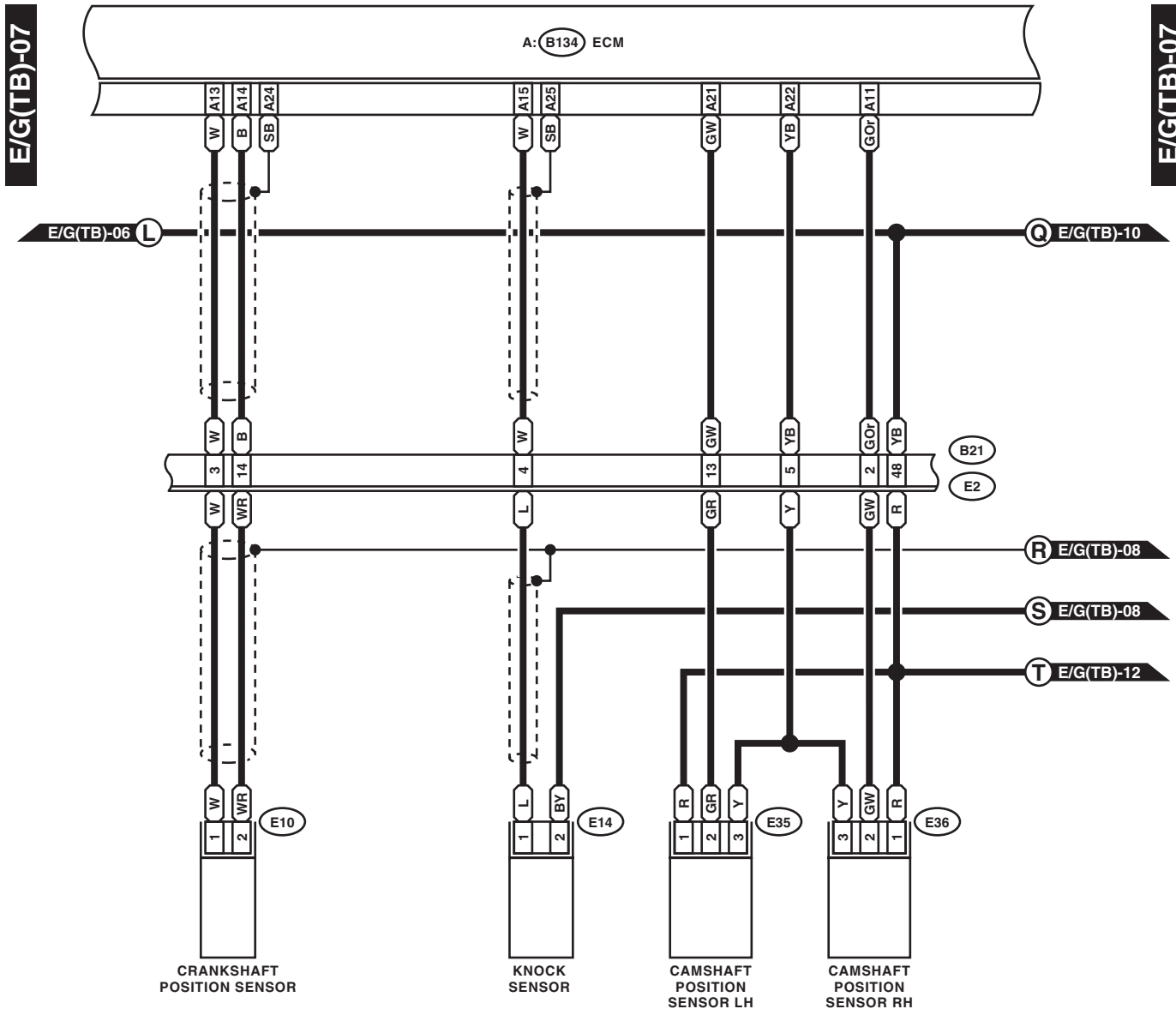

- E10 (LIGHT GRAY)
- E14 (LIGHT GRAY)

- E35 (LIGHT GRAY)
- E36 (LIGHT GRAY)

A: B134

1	2	3	4	5	6	7
8	9	10	11	12	13	14
15	16	17	18	19	20	21
22	23	24	25	26	27	28
29	30	31	32	33	34	

B21

1	2	3	4	5	6	7	8	9	10	11
12	13	14	15	16	17	18	19	20	21	22
23	24	25	26	27	28	29	30	31	32	33
34	35	36	37	38	39	40	41	42	43	44
45	46	47	48	49	50	51	52	53	54	

WI-16888

# Engine Electrical System

WIRING SYSTEM

Brought to you by *Chris Studios*  
 NOT FOR SALE

E/G(TB)-08

E/G(TB)-08

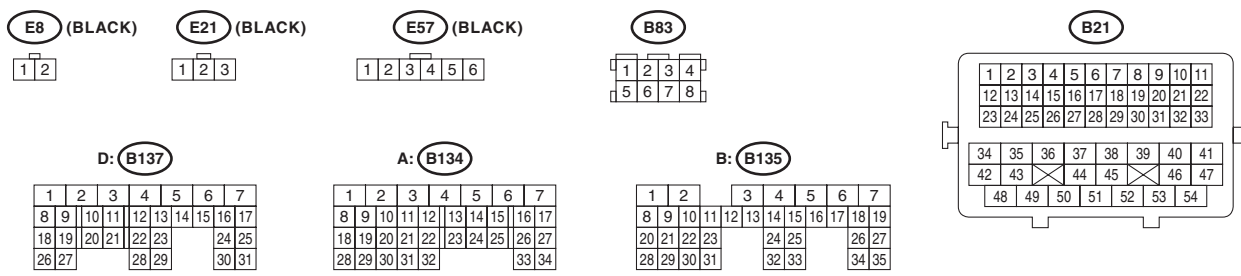
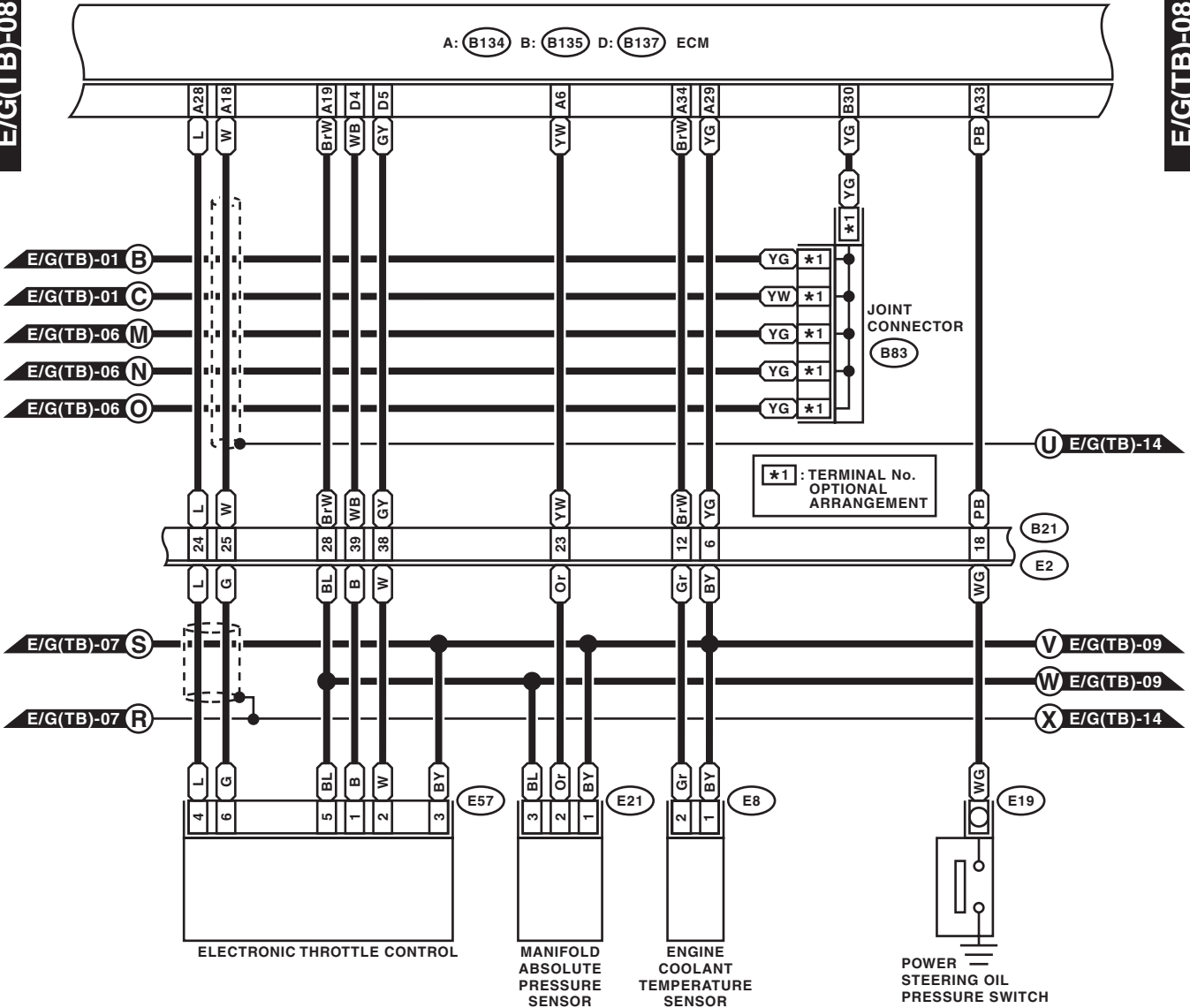

WI-16889

# Engine Electrical System

Brought to you by Eris Studios  
NOT FOR RESALE

WIRING SYSTEM

E/G(TB)-09

E/G(TB)-09

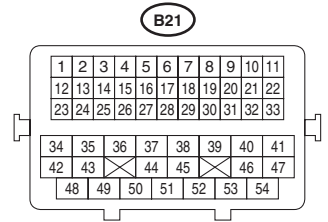
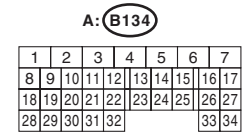
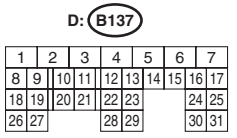
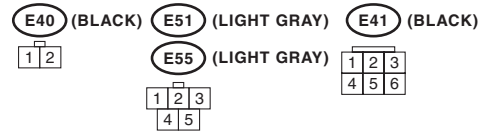
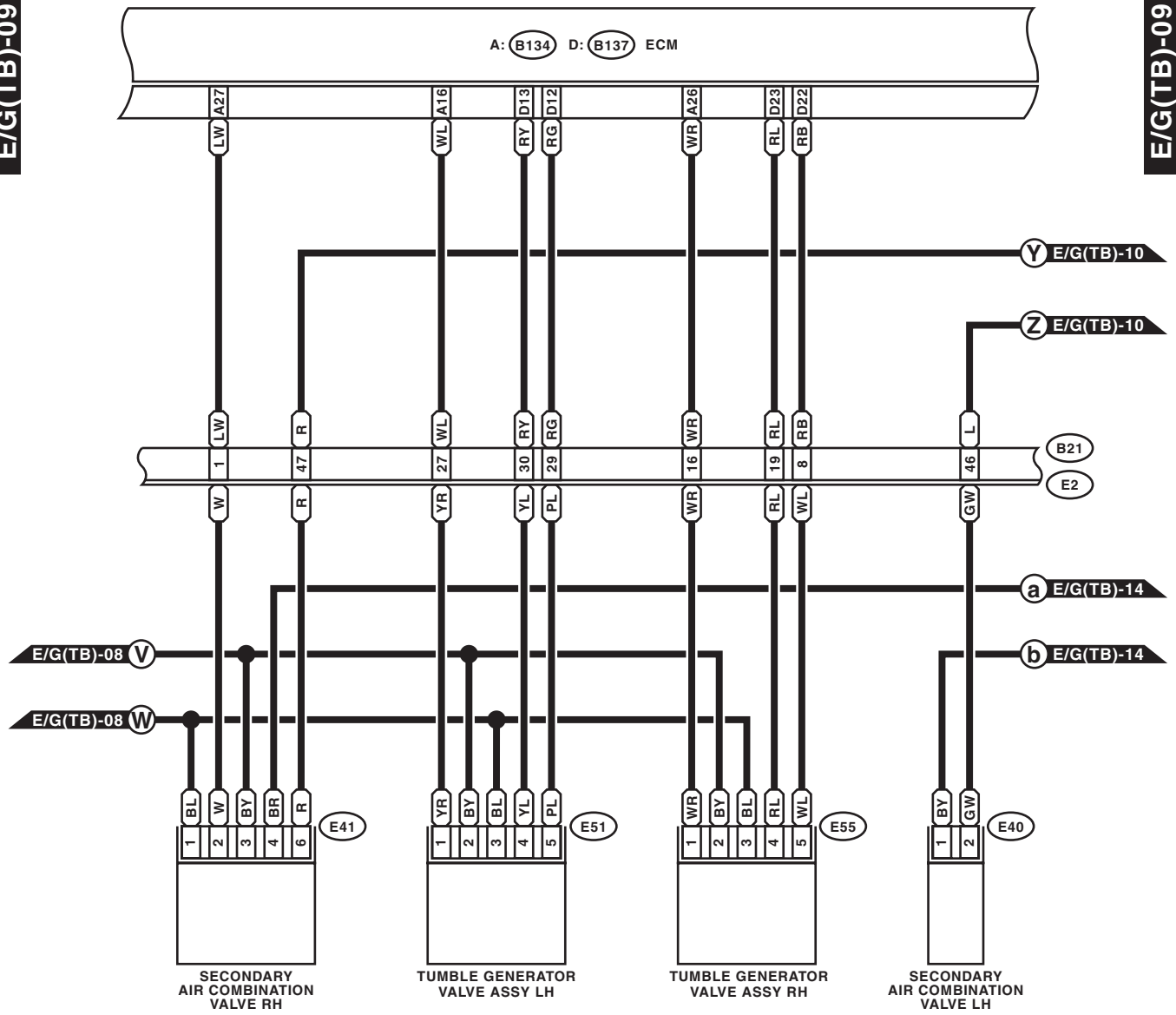

WI-16890

# Engine Electrical System

WIRING SYSTEM

Brought to you by *Chris Studios*  
NO REUSE OR RESALE

E/G(TB)-10

E/G(TB)-10

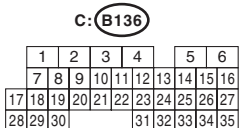
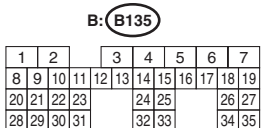
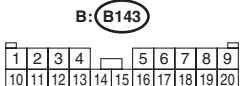
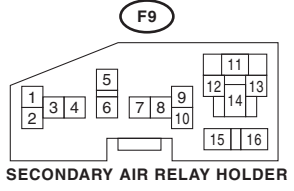
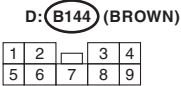
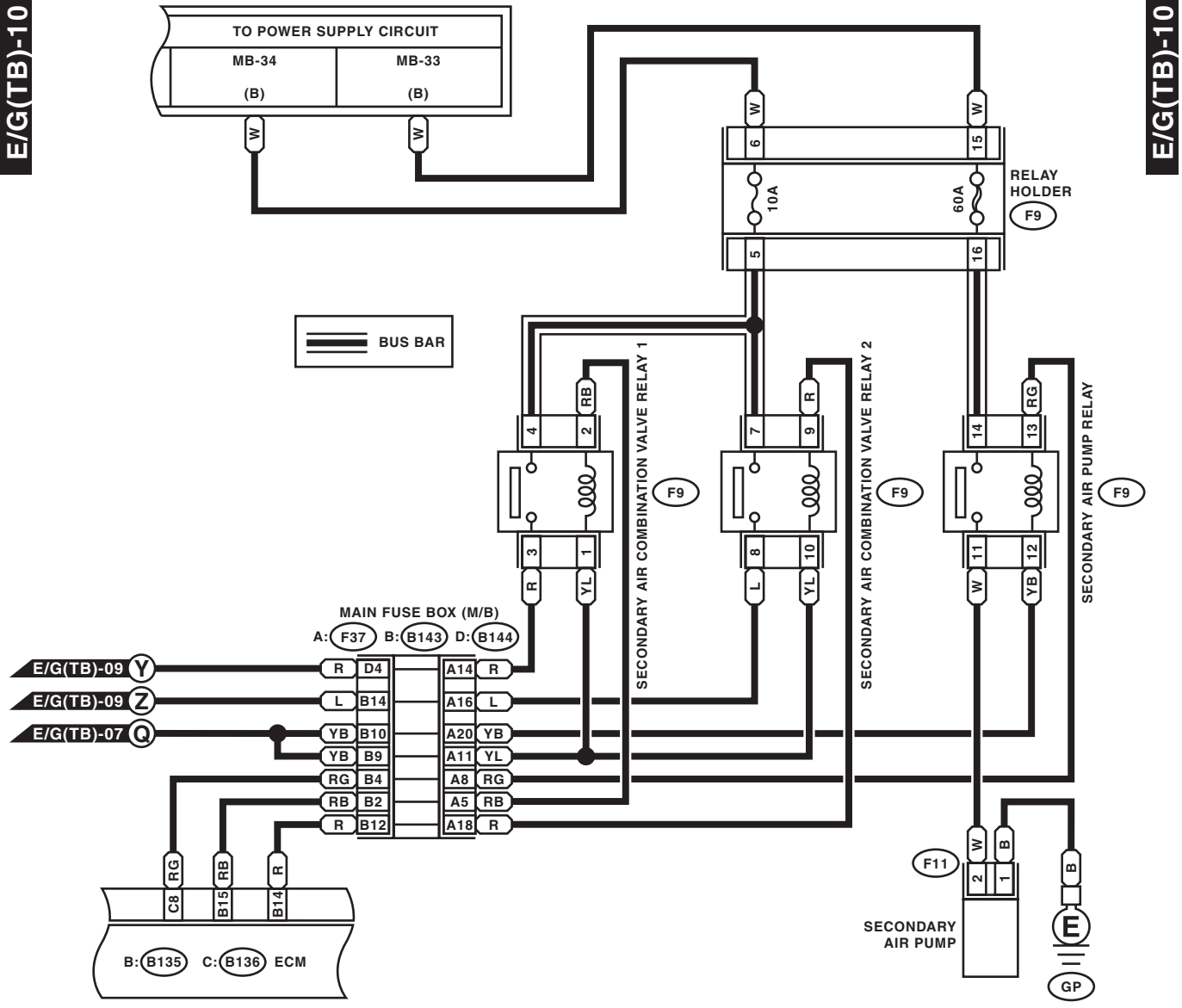

WI-16891

# Engine Electrical System

## WIRING SYSTEM

Brought to you by Eris Studios  
NOT FOR RESALE

E/G(TB)-11

E/G(TB)-11

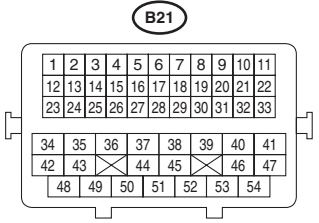
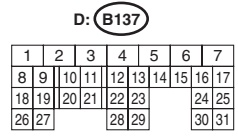
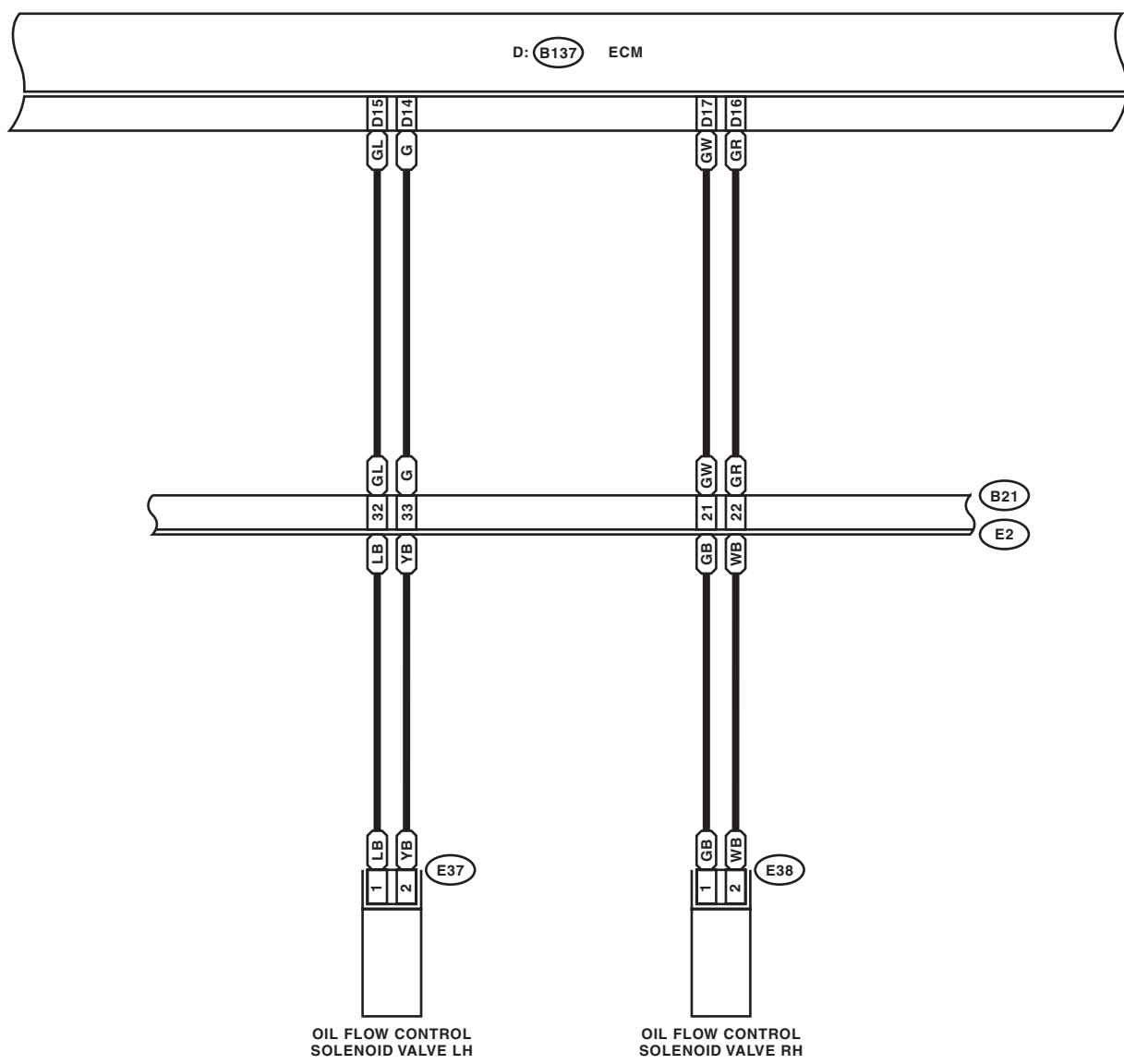

WI-16892

# Engine Electrical System

WIRING SYSTEM

Brought to you by *Chris Studios*  
NOT FOR SALE

E/G(TB)-12

E/G(TB)-12

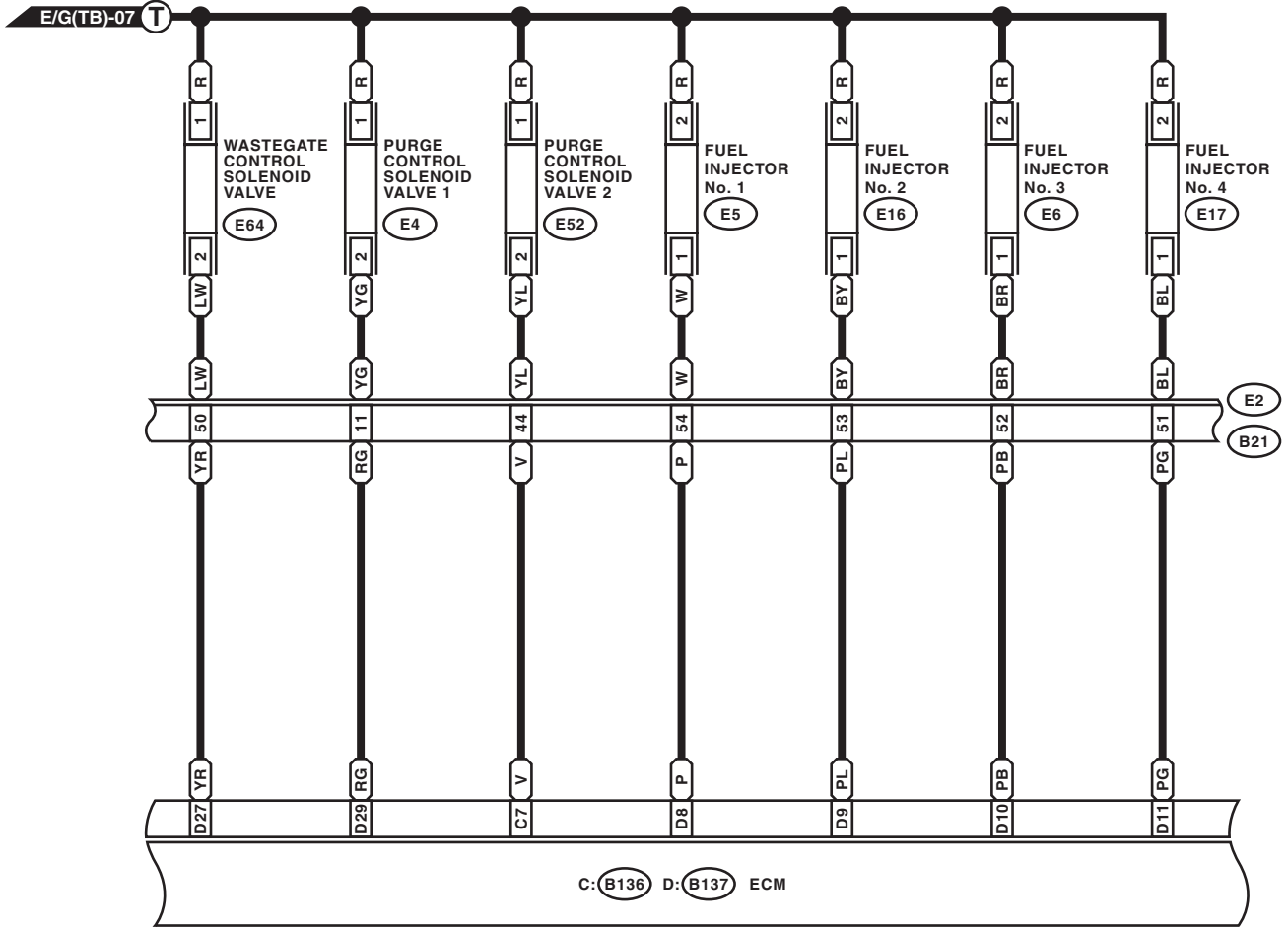

**E4 (BLACK)**    **E5 (DARK GRAY)**    **D: (B137)**  
**E52 (BLACK)**    **E6 (DARK GRAY)**

1	2	3	4	5	6	7			
8	9	10	11	12	13	14	15	16	17
18	19	20	21	22	23	24	25	26	27
28	29	30	31						

  
**E64 (BLUE)**    **E16 (DARK GRAY)**    **C: (B136)**  

1	2	3	4	5	6					
7	8	9	10	11	12	13	14	15	16	
17	18	19	20	21	22	23	24	25	26	27
28	29	30	31	32	33	34	35			

  
**E17 (DARK GRAY)**    **B21**  

1	2
---	---

1	2	3	4	5	6	7	8	9	10	11
12	13	14	15	16	17	18	19	20	21	22
23	24	25	26	27	28	29	30	31	32	33
34	35	36	37	38	39	40	41			
42	43	44	45	46	47					
48	49	50	51	52	53	54				

WI-16893

# Engine Electrical System

Brought to you by Eris Studios  
NOT FOR RESALE

WIRING SYSTEM

E/G(TB)-13

E/G(TB)-13

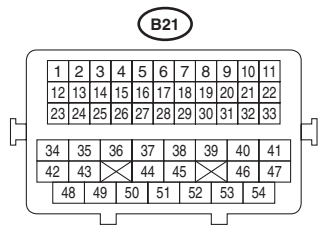
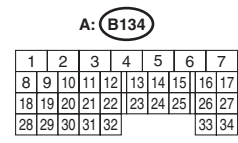
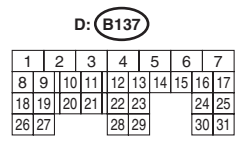
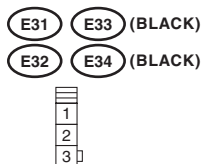
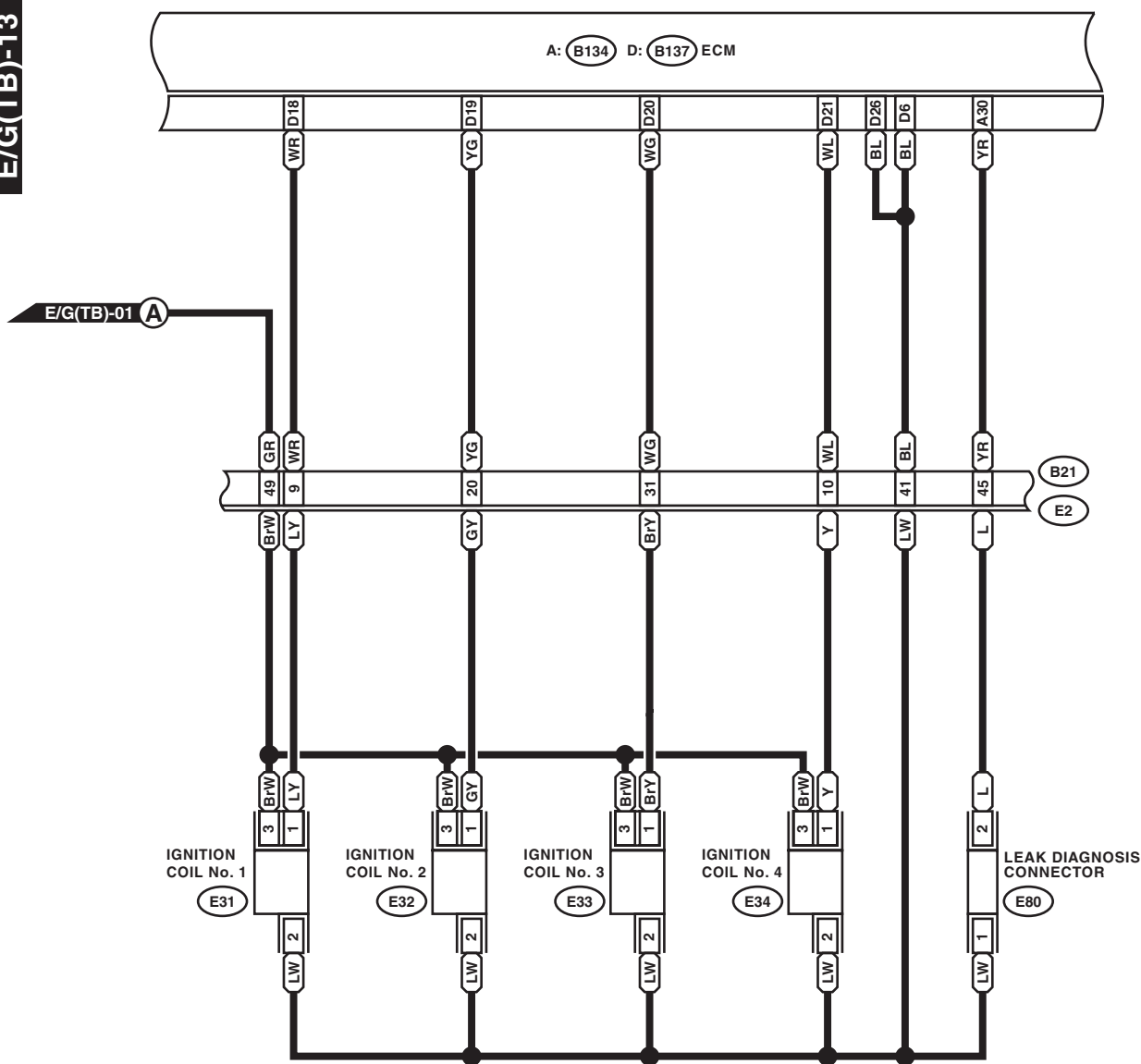

WI-16894



# Engine Electrical System

## WIRING SYSTEM

Brought to you by *Chris Studios*  
 NOT FOR SALE

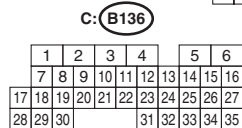
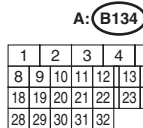
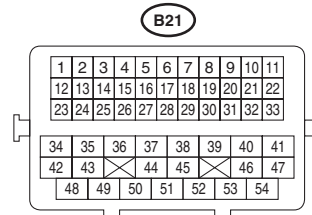
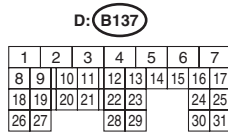
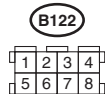
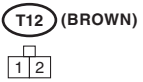
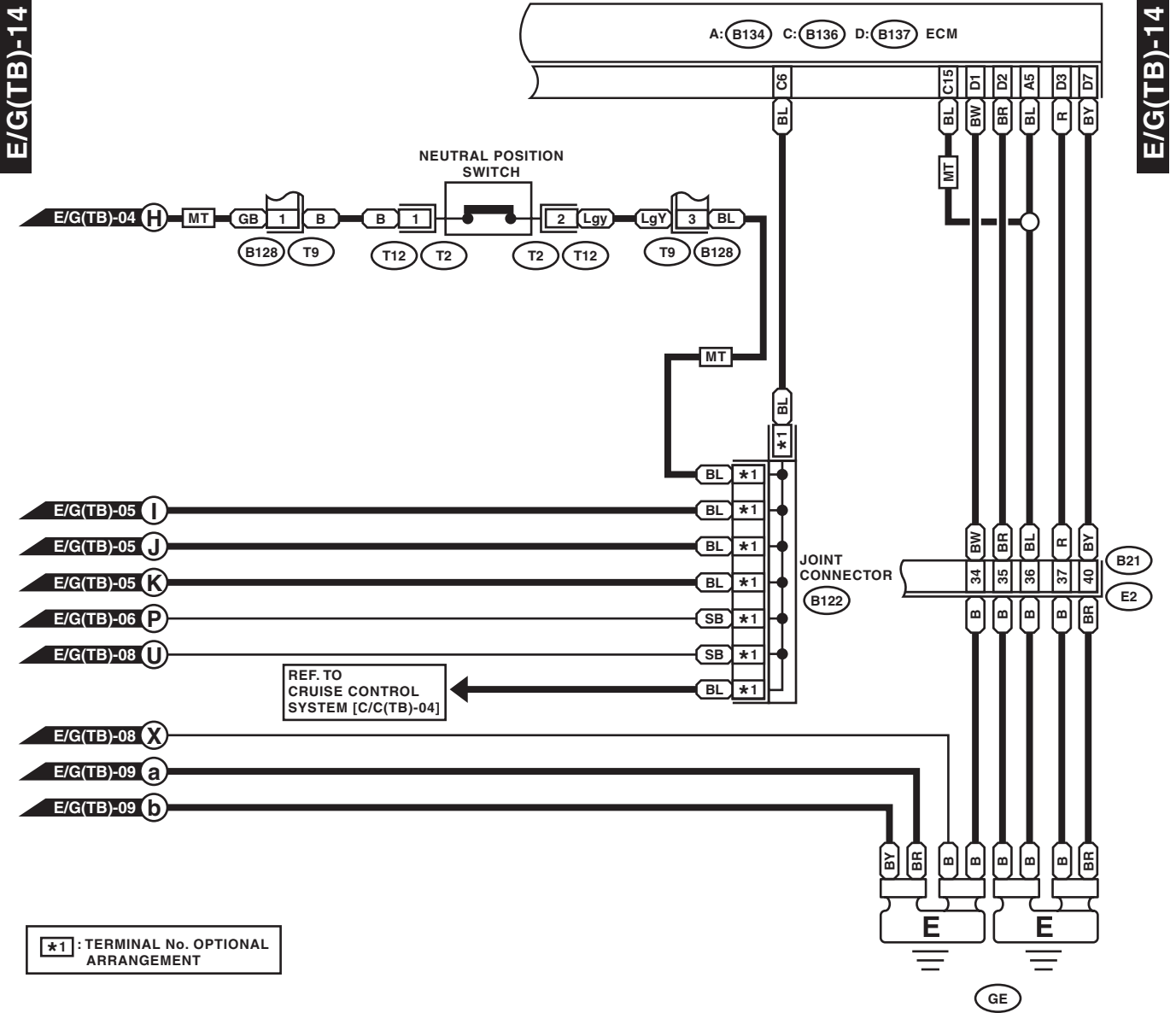

WI-16895

# Radiator Fan System

WIRING SYSTEM

Brought to you by Eris Studios  
NOT FOR RESALE

## 6. Radiator Fan System

### A: WIRING DIAGRAM

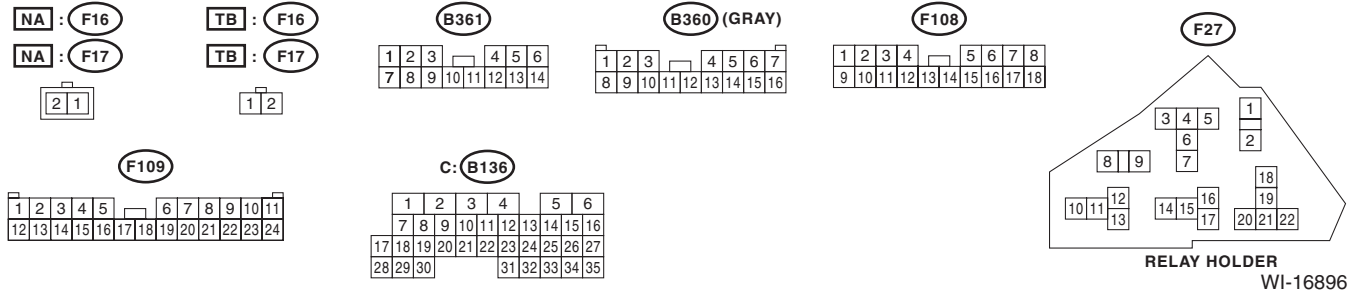
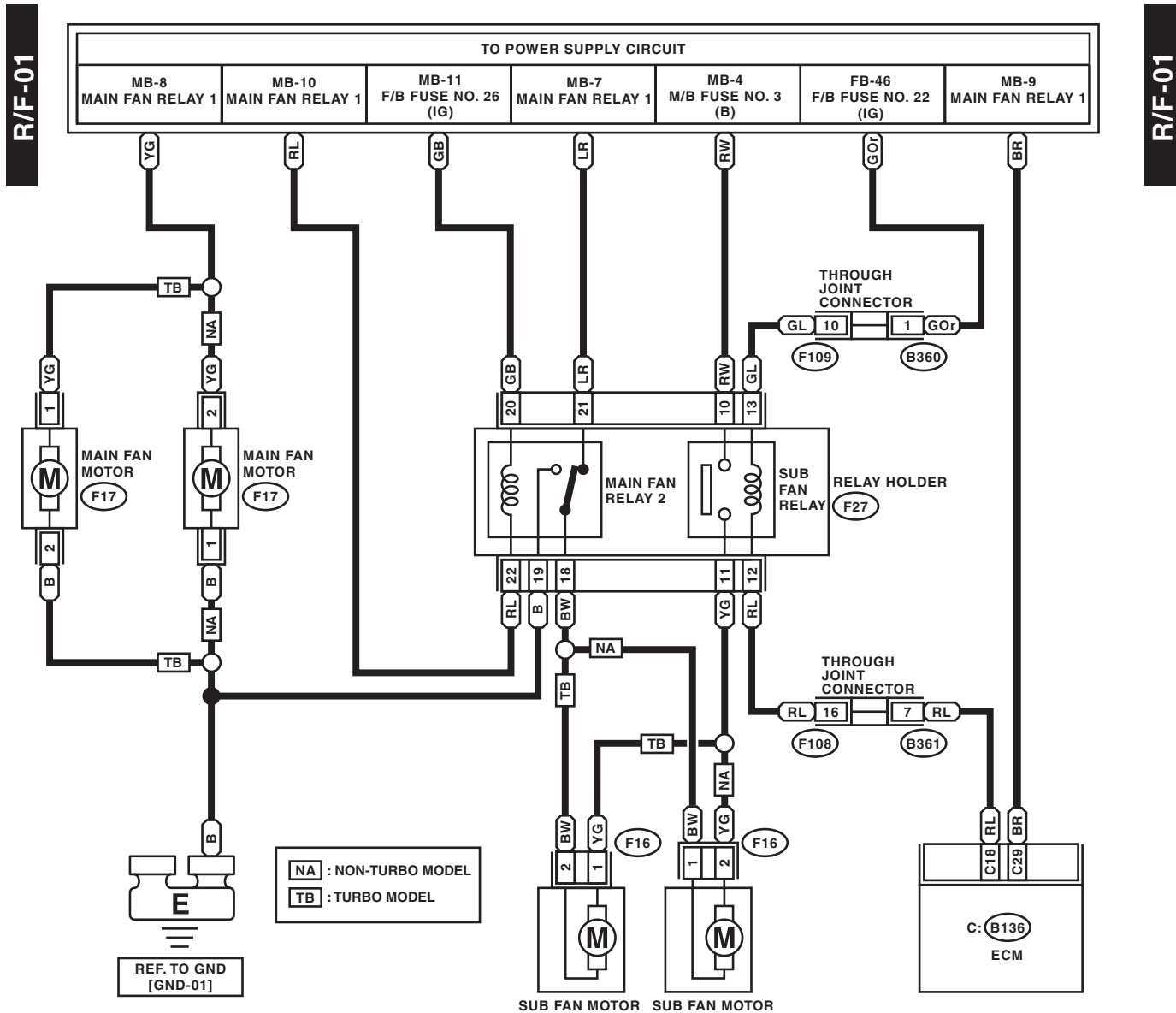

## 7. Charging System

### A: WIRING DIAGRAM

**CHG-01**

**CHG-01**

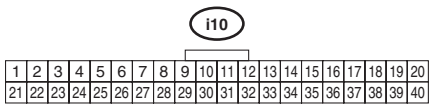
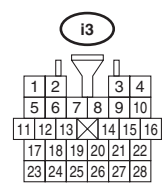
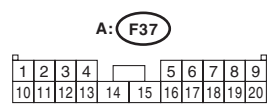
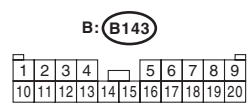
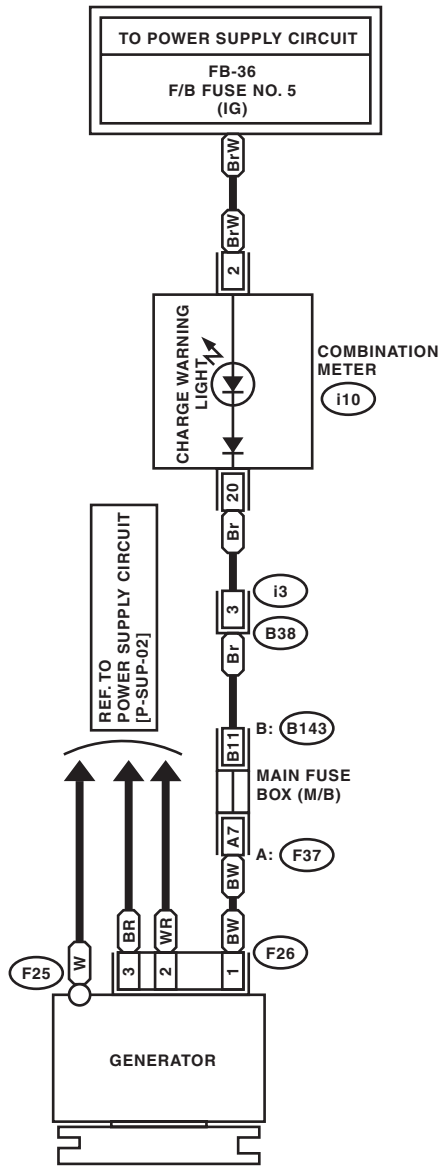

# Starter System

WIRING SYSTEM

Brought to you by Eris Studios  
NOT FOR RESALE

## 8. Starter System

### A: WIRING DIAGRAM

#### 1. NON-TURBO MODEL

- Transmission serial No. 4078112 or earlier

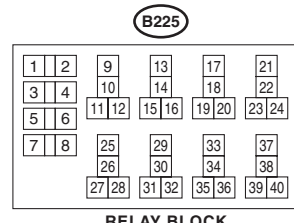
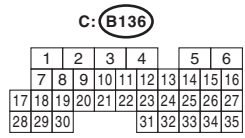
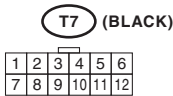
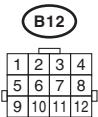
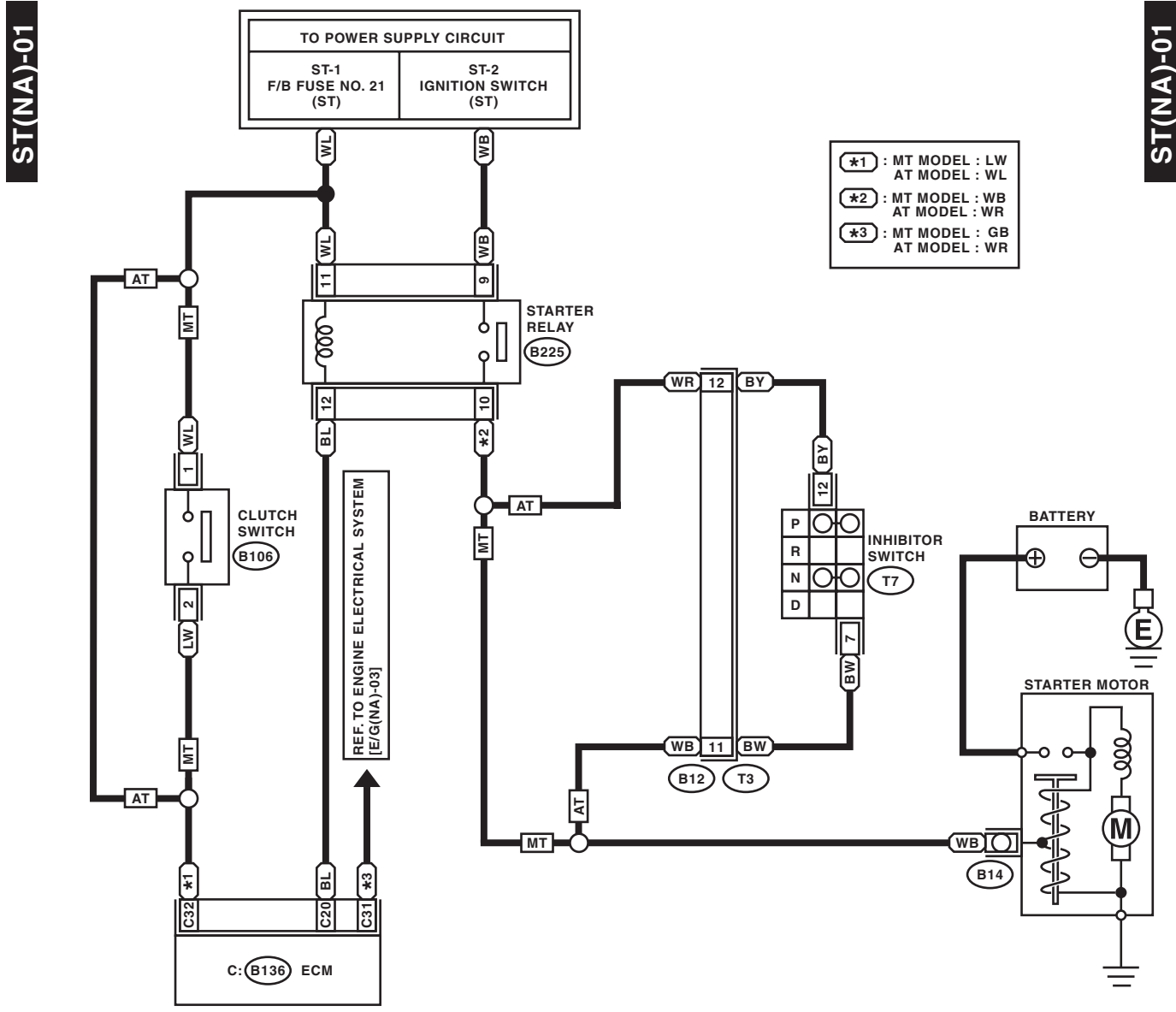

WI-16898

# Starter System

WIRING SYSTEM

Brought to you by *Chris Studios*  
NOT FOR SALE

- Transmission serial No. 4078113 or later

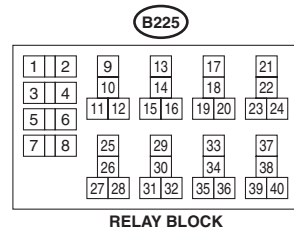
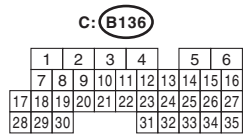
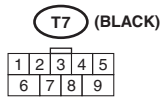
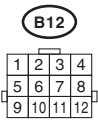
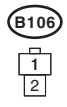
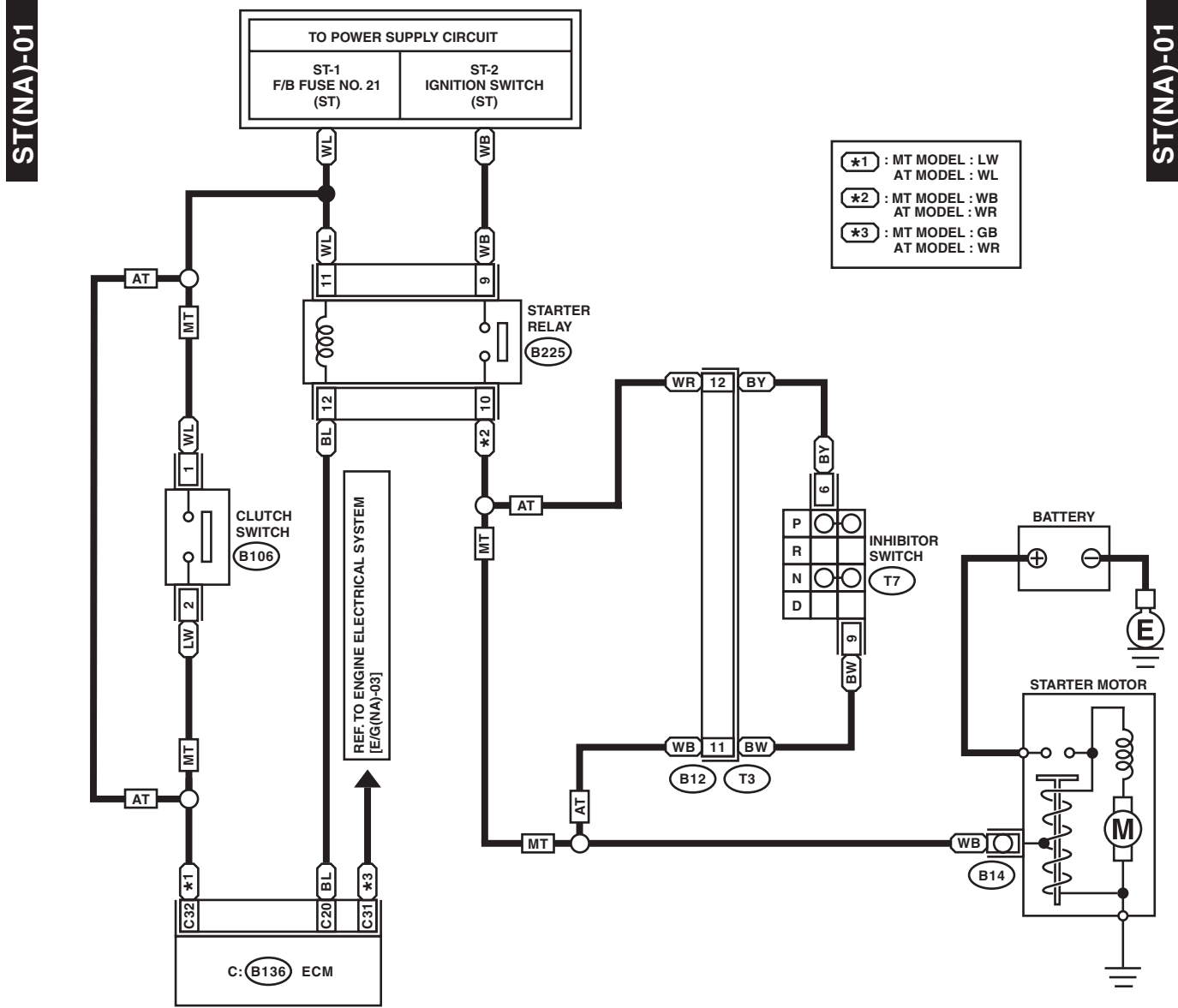

WI-21043

# Starter System

Brought to you by Eris Studios  
NOT FOR RESALE

## WIRING SYSTEM

### 2. TURBO MODEL

- Transmission serial No. 4078112 or earlier

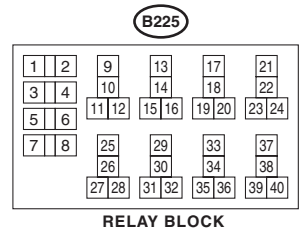
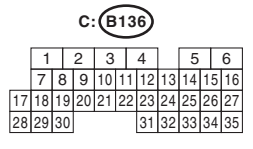
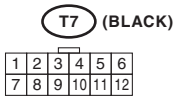
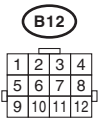
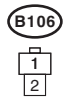
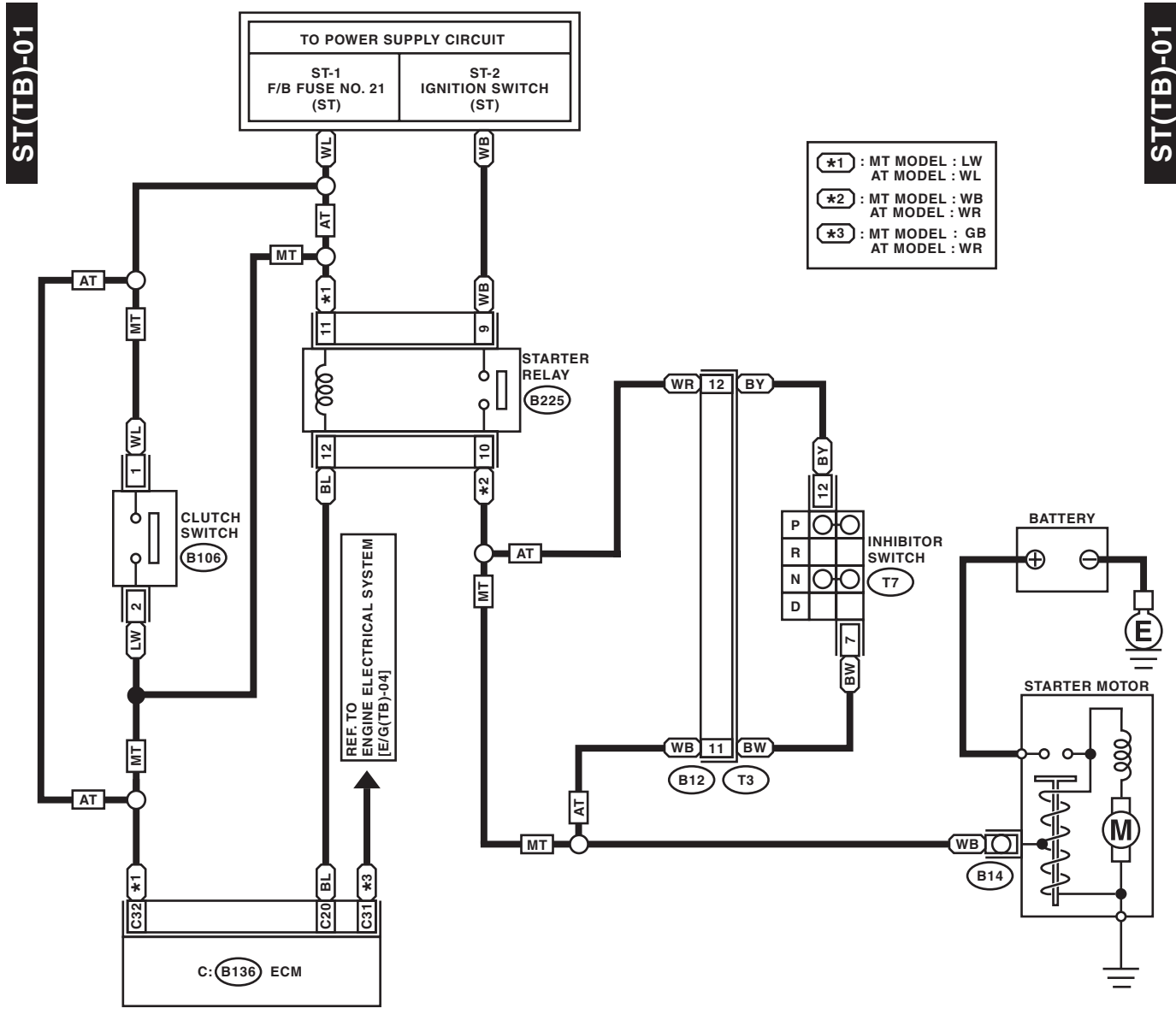

WI-16899

# Starter System

WIRING SYSTEM

Brought to you by *Chris Studios*  
NOT FOR SALE

- Transmission serial No. 4078113 or later

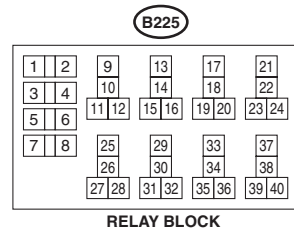
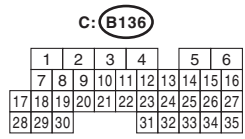
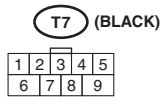
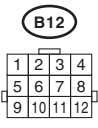
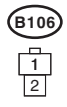
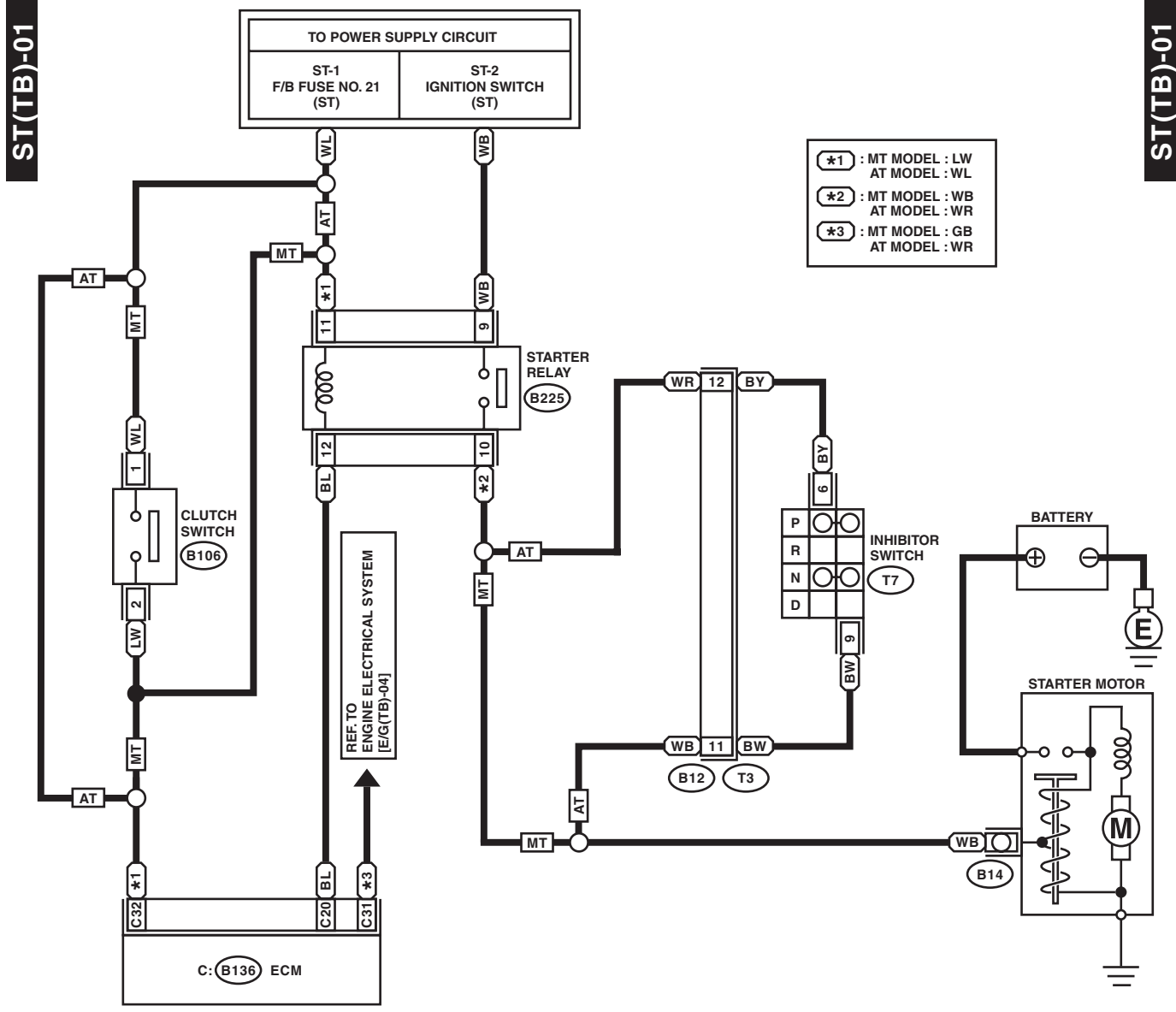

WI-21044

# Remote Engine Start System

Brought to you by Eris Studios  
NOT FOR SALE

## WIRING SYSTEM

### 9. Remote Engine Start System

#### A: WIRING DIAGRAM

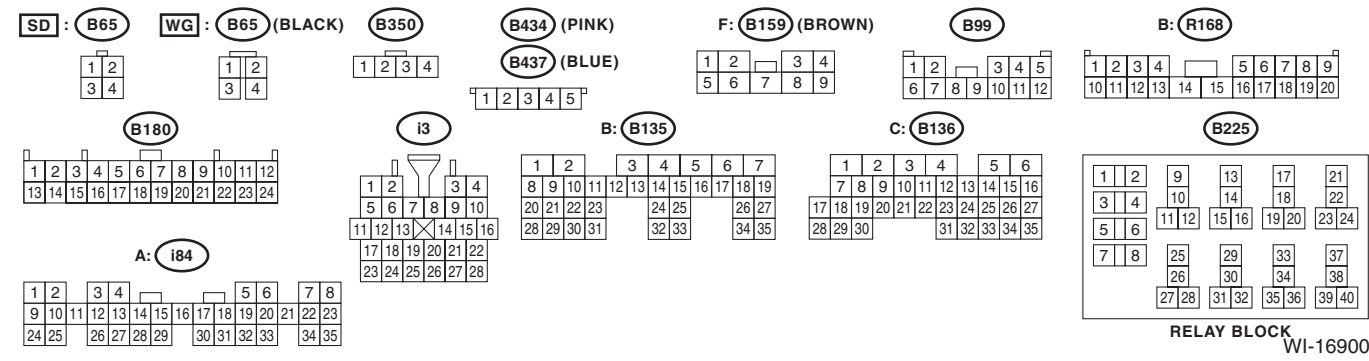
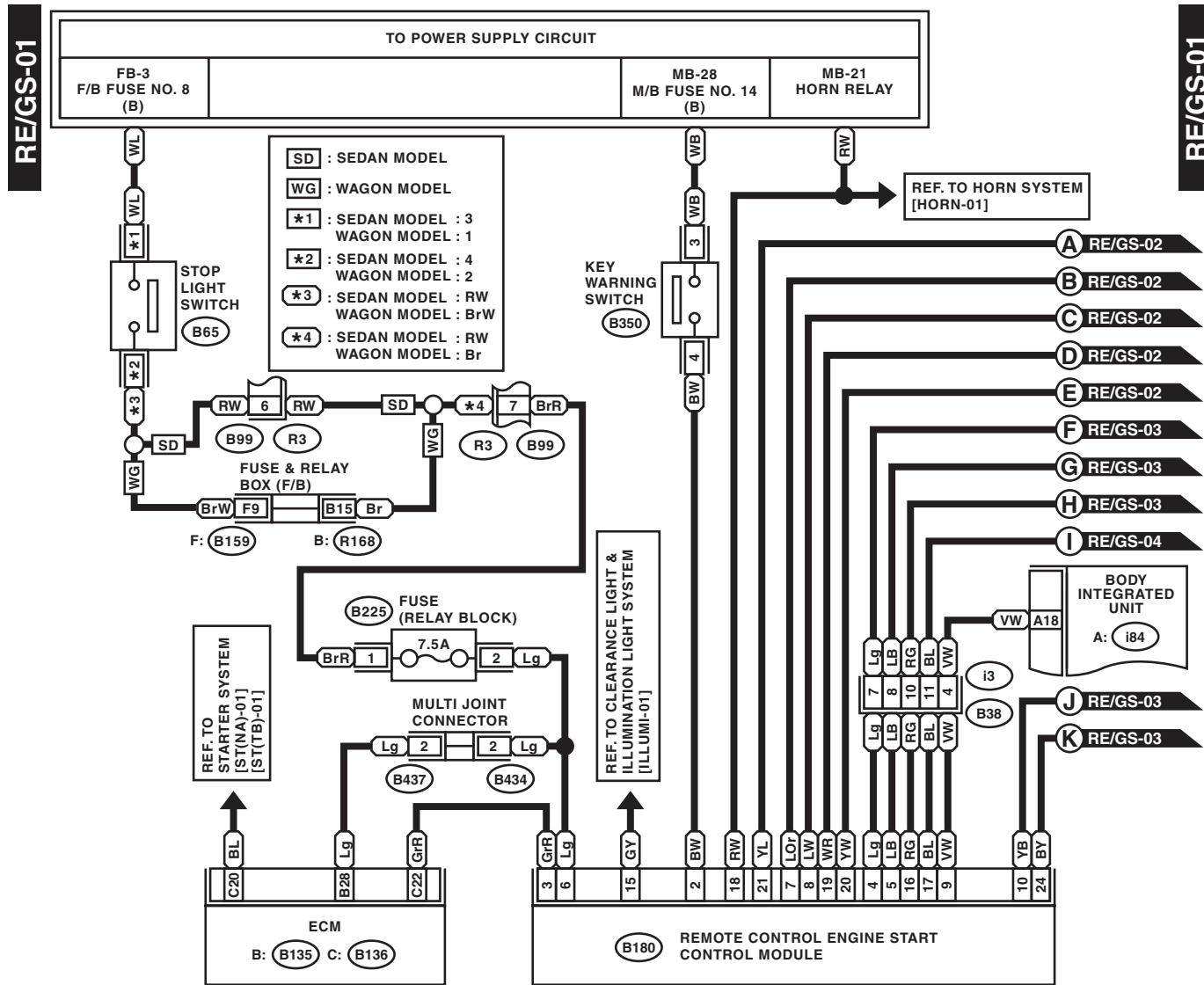



# Remote Engine Start System

WIRING SYSTEM

Brought to you by  
NOTICE: FOR SALE  
Chris Studios

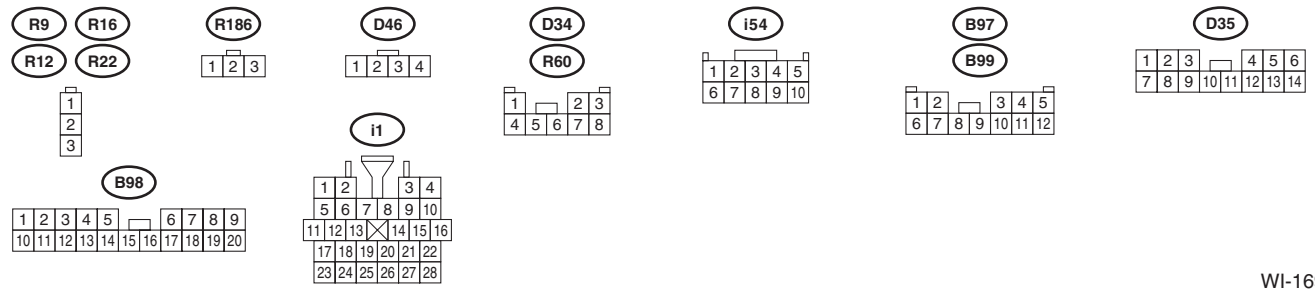
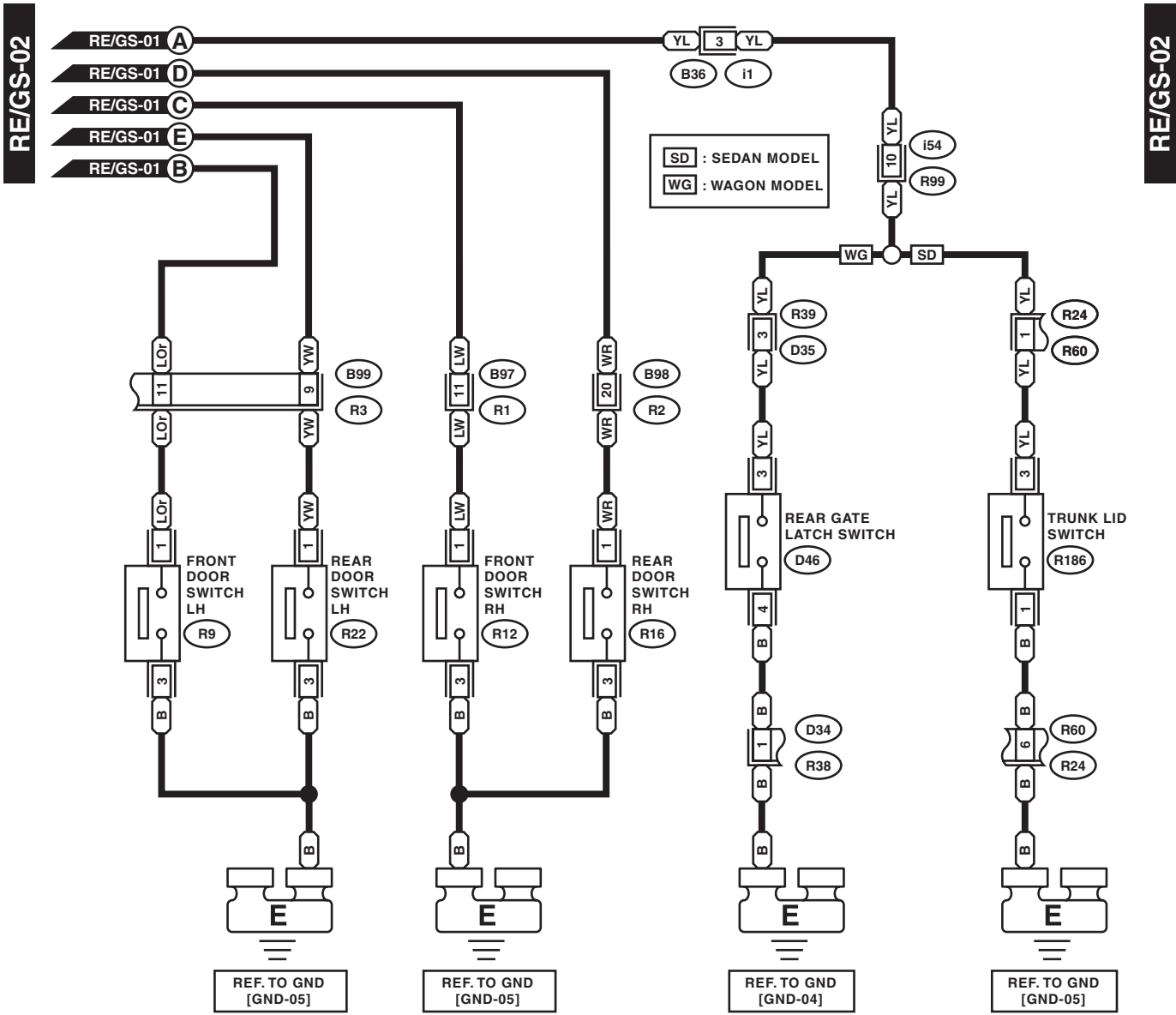

WI-16901

# Remote Engine Start System

Brought to you by Eris Studios  
NOT FOR RESALE

## WIRING SYSTEM

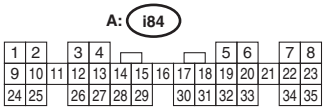
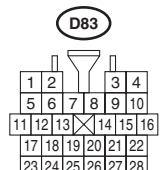
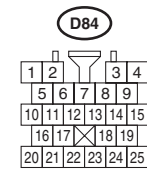
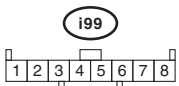
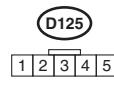
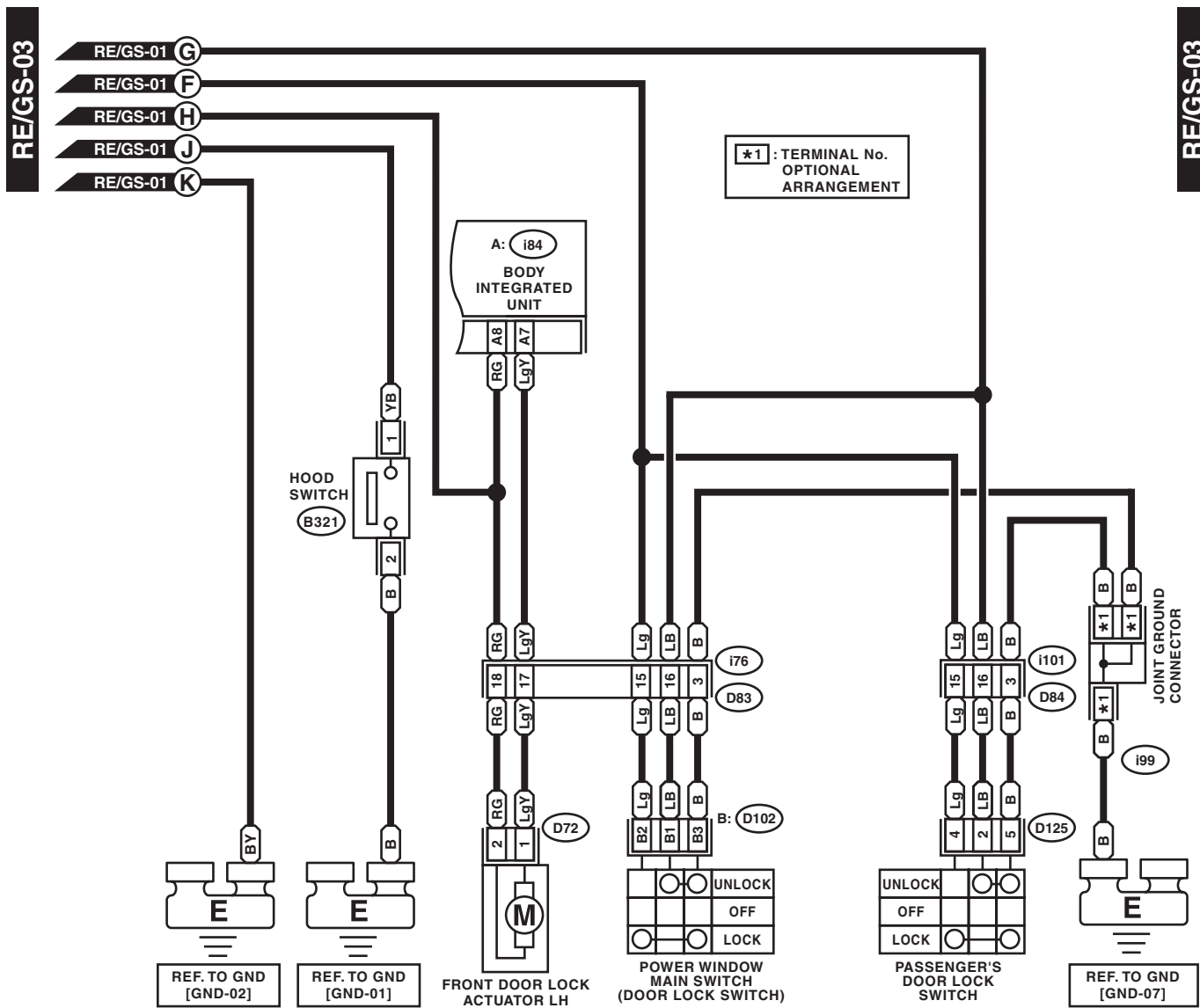

WI-16902

# Remote Engine Start System

WIRING SYSTEM

Brought to you by *Chris Studios*  
NOT FOR SALE

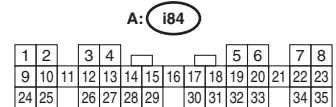
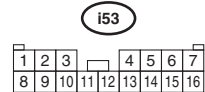
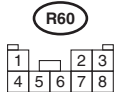
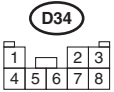
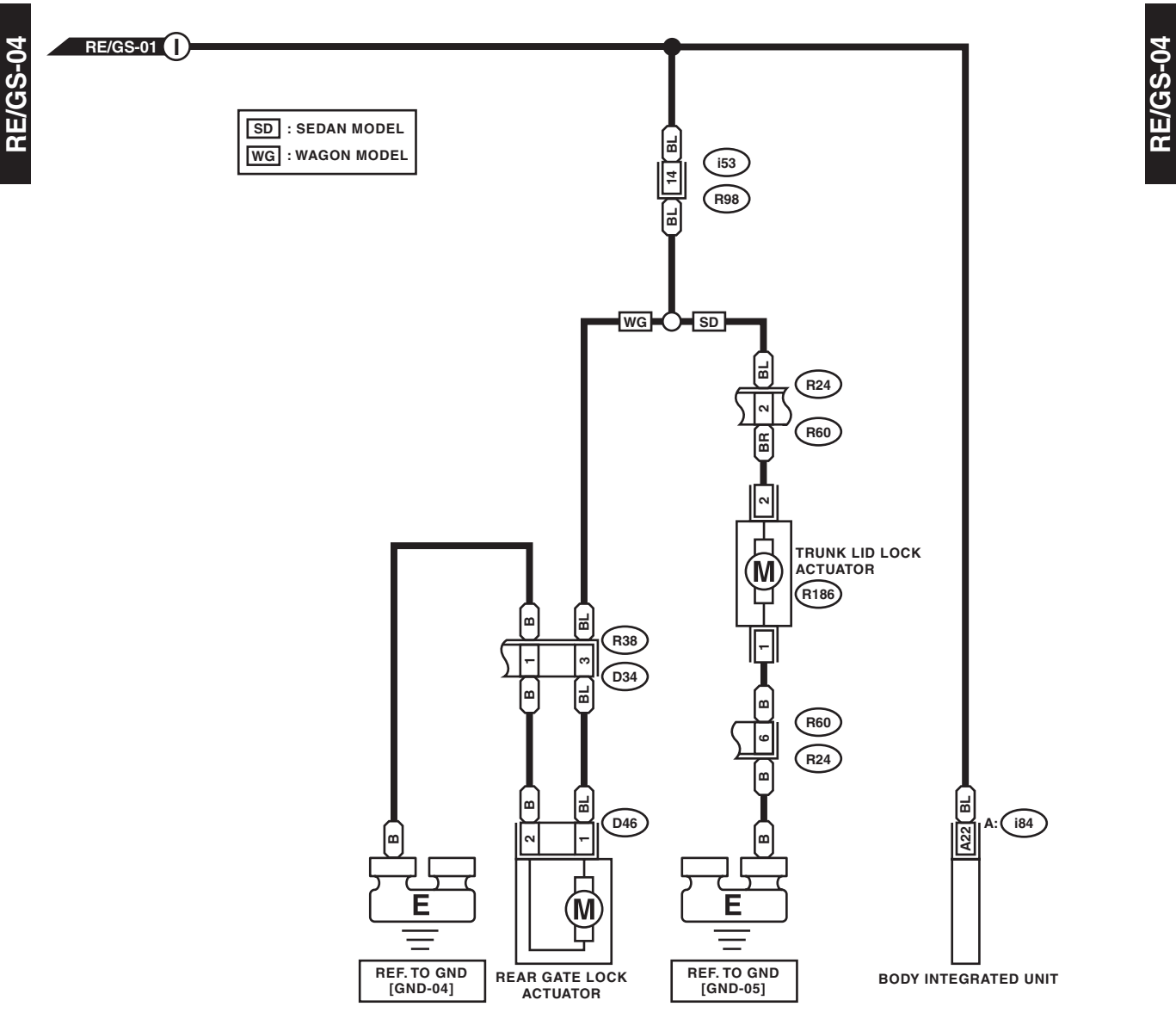

WI-16903

## WIRING SYSTEM

### 10. AT Control System

#### A: WIRING DIAGRAM

##### 1. TRANSMISSION SERIAL NO. 3966774 OR EARLIER

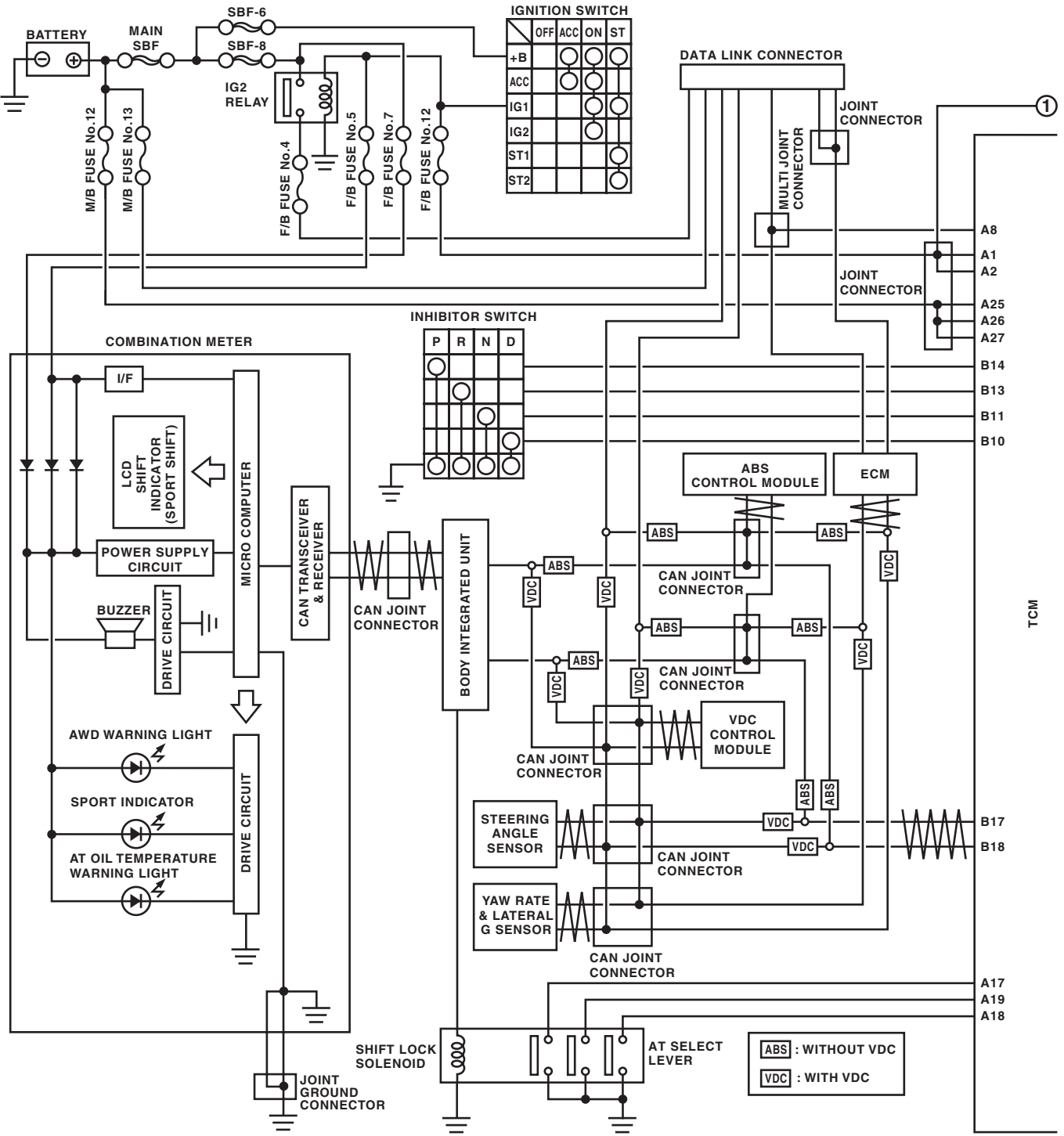

WI-16904

# AT Control System

## WIRING SYSTEM

Brought to you by  
NOT FOR SALE  
Chris Studios

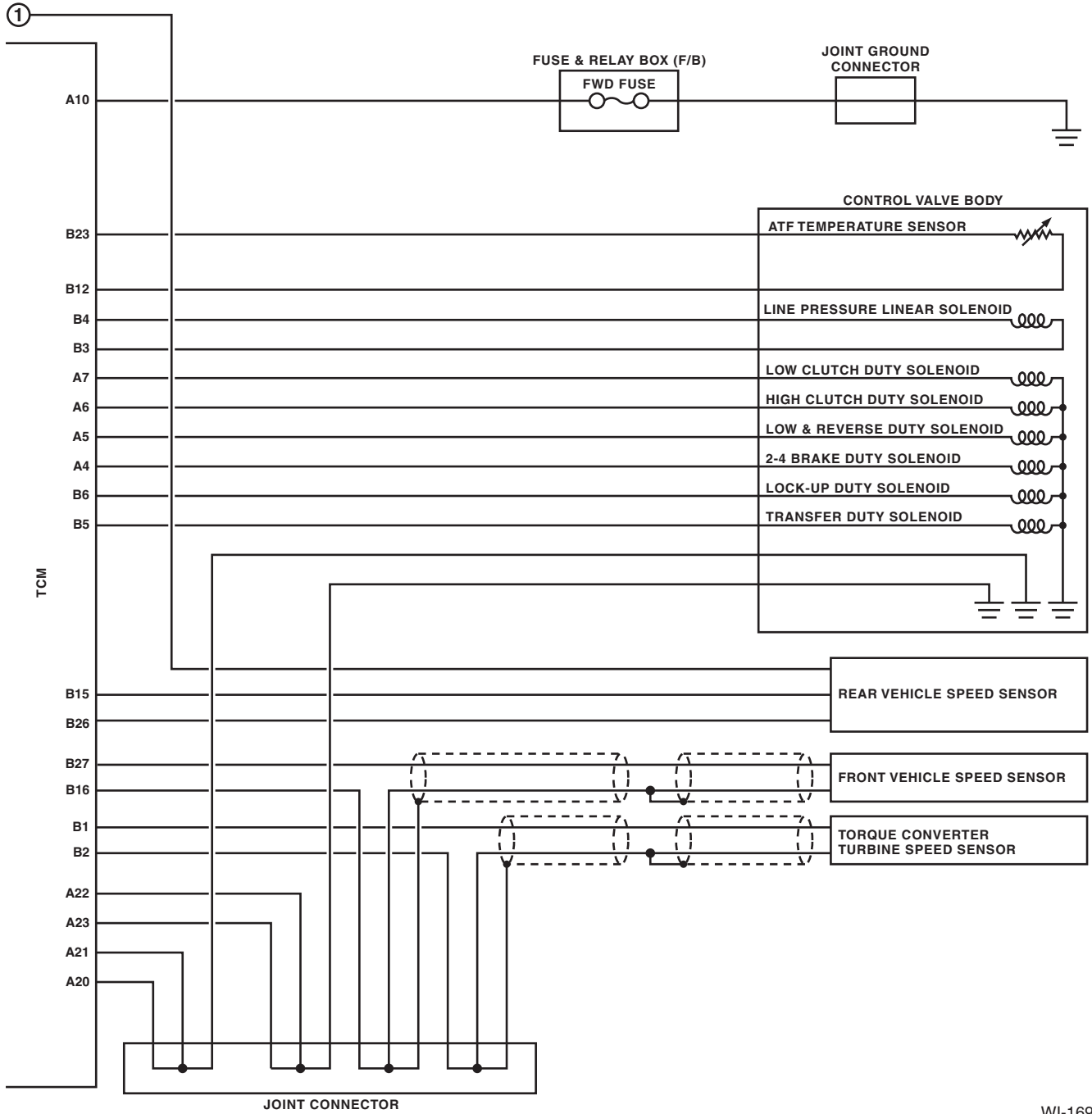

WI-16905

# AT Control System

Brought to you by Eris Studios  
NOT FOR RESALE

## WIRING SYSTEM

AT-01

AT-01

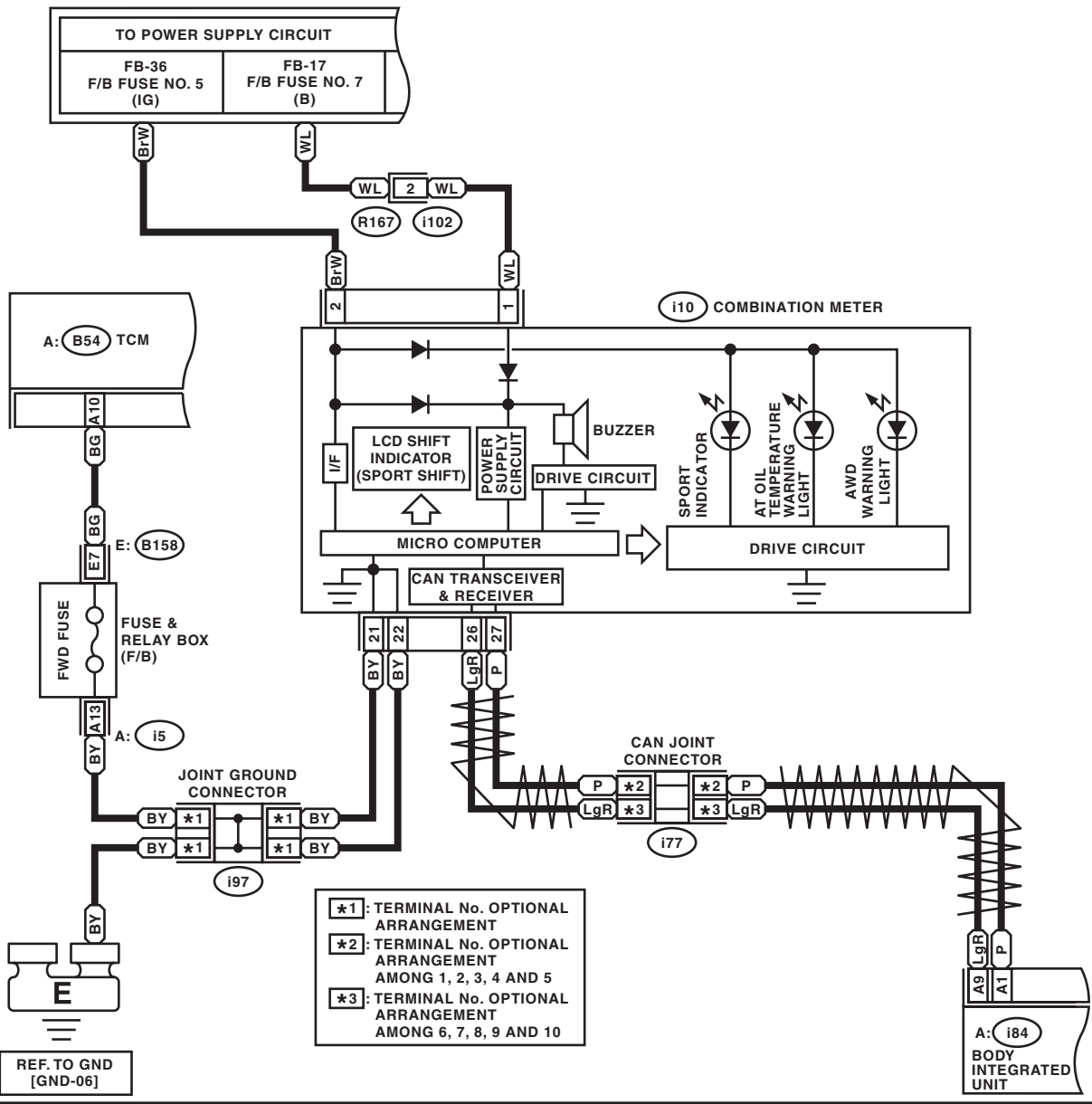

- \*1: TERMINAL No. OPTIONAL ARRANGEMENT
- \*2: TERMINAL No. OPTIONAL ARRANGEMENT AMONG 1, 2, 3, 4 AND 5
- \*3: TERMINAL No. OPTIONAL ARRANGEMENT AMONG 6, 7, 8, 9 AND 10

E: (B158)

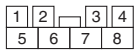

i97

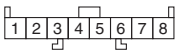

i77

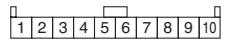

i102



A: i5

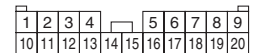

A: (B54)

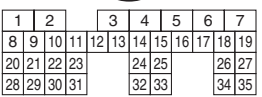

A: (i84)



i10

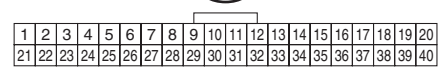

WI-16906

# AT Control System

## WIRING SYSTEM

Brought to you by *Chris Studios*  
 NOT FOR SALE

AT-02

AT-02

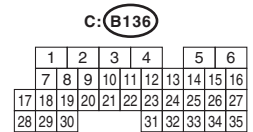
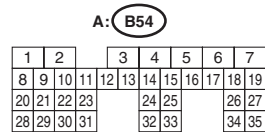
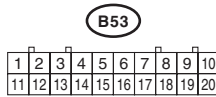
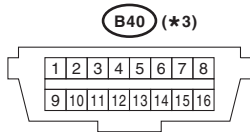
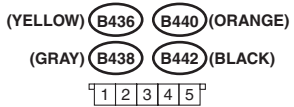
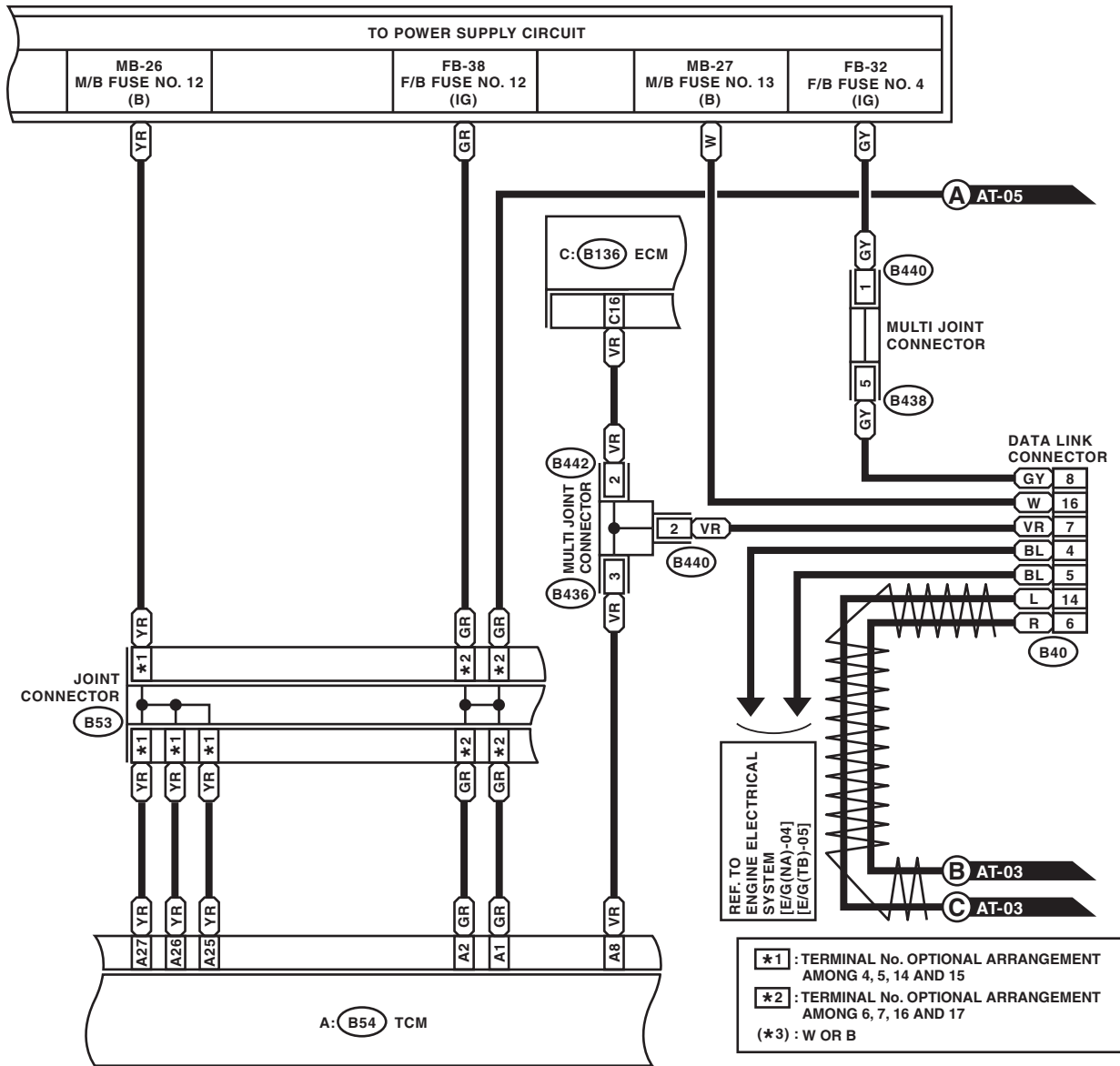

WI-18765

# AT Control System

Brought to you by Eris Studios  
NOT FOR RESALE

## WIRING SYSTEM

AT-03

ABS : WITHOUT VDC  
VDC : WITH VDC

AT-03

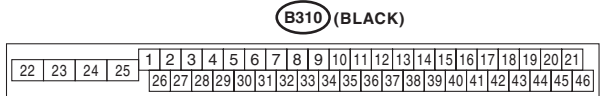
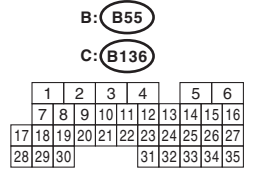
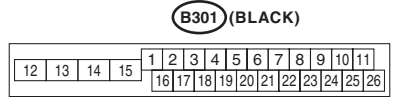
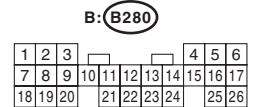
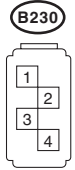
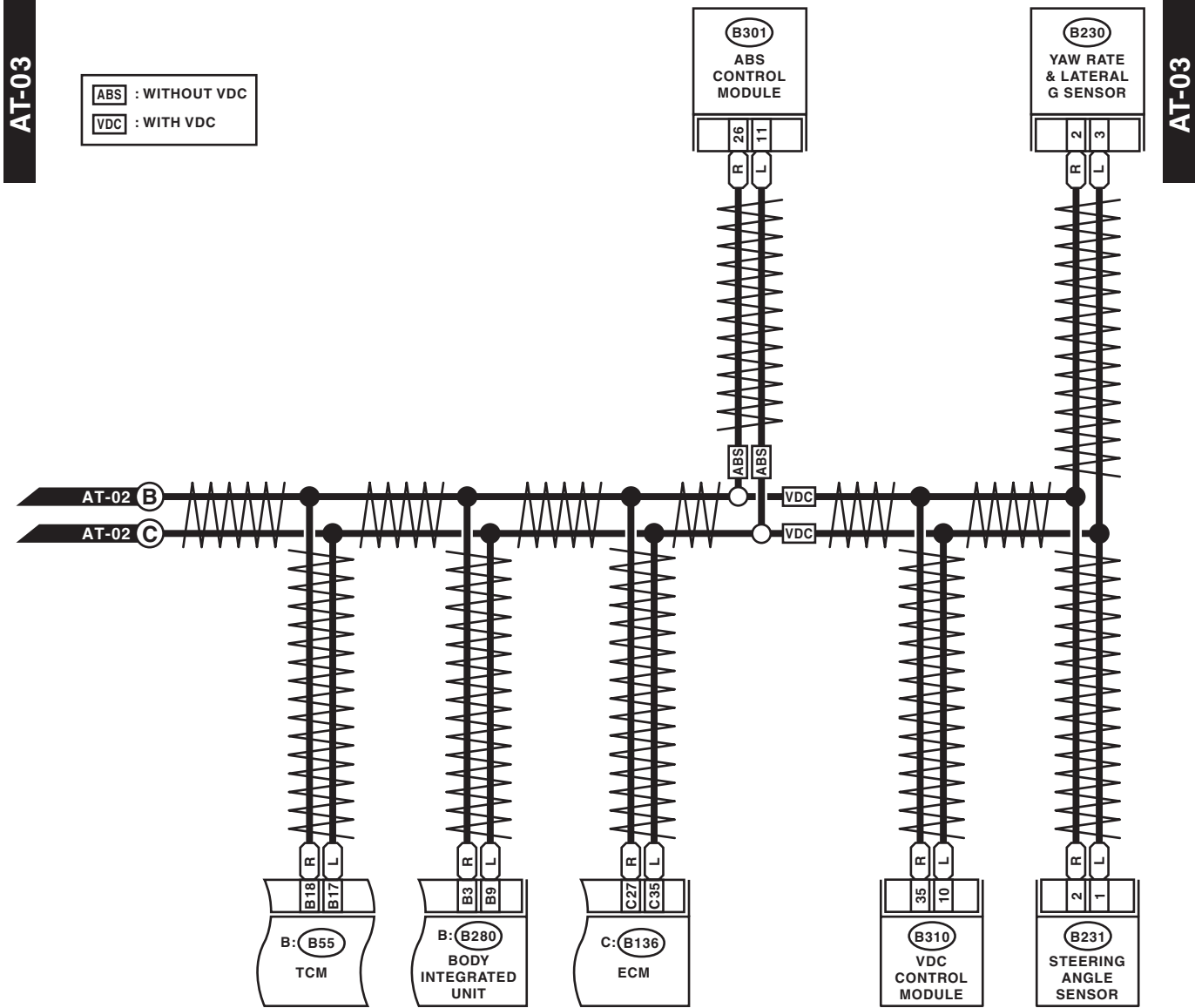

WI-16908



# AT Control System

## WIRING SYSTEM

Brought to you by *Chris Studios*  
 NOT FOR SALE

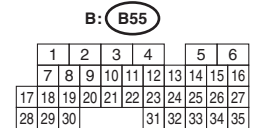
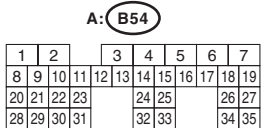
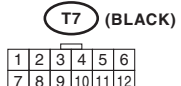
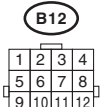
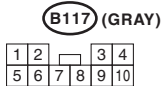
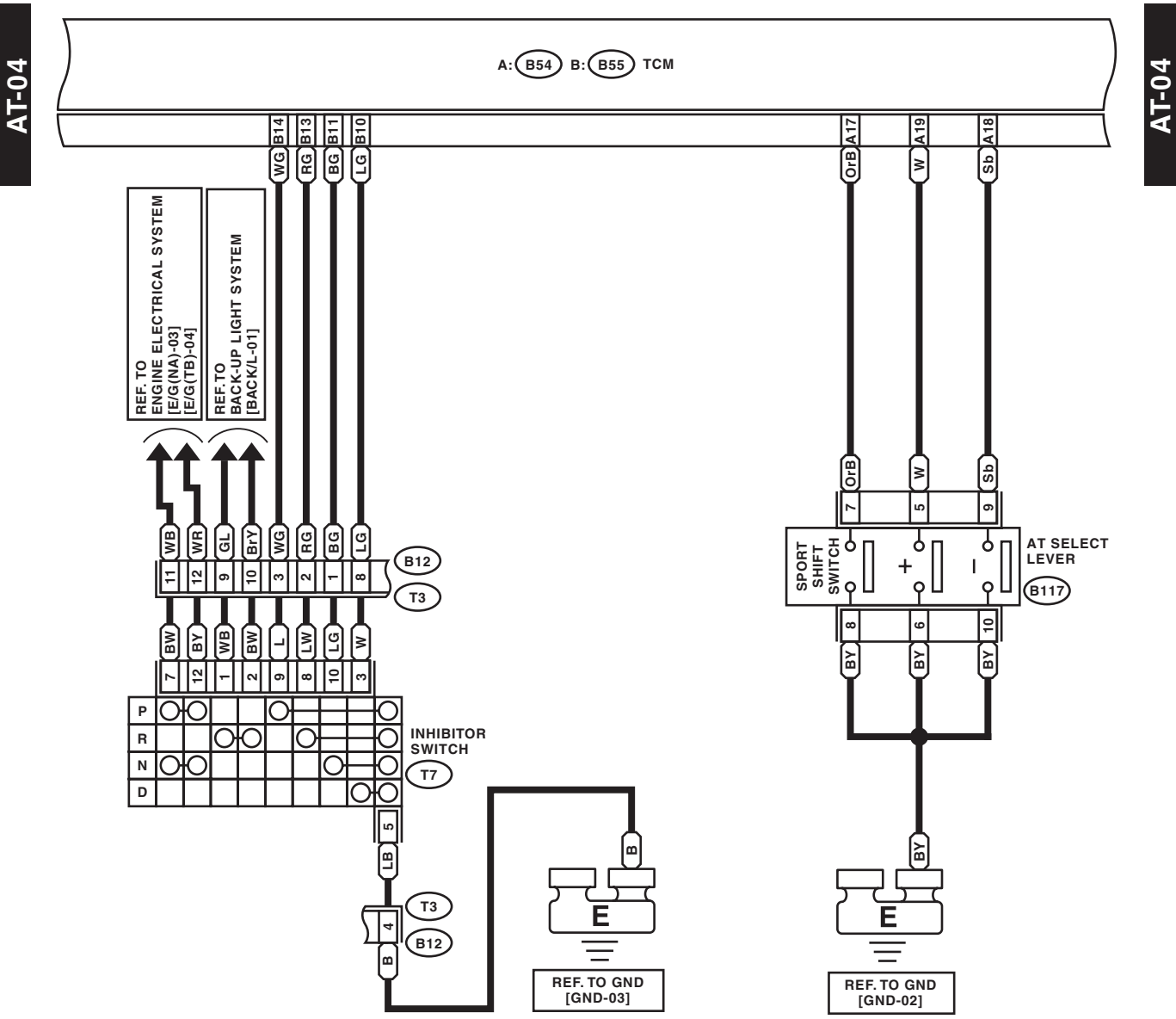

WI-16909

# AT Control System

Brought to you by Eris Studios  
NOT FOR RESALE

## WIRING SYSTEM

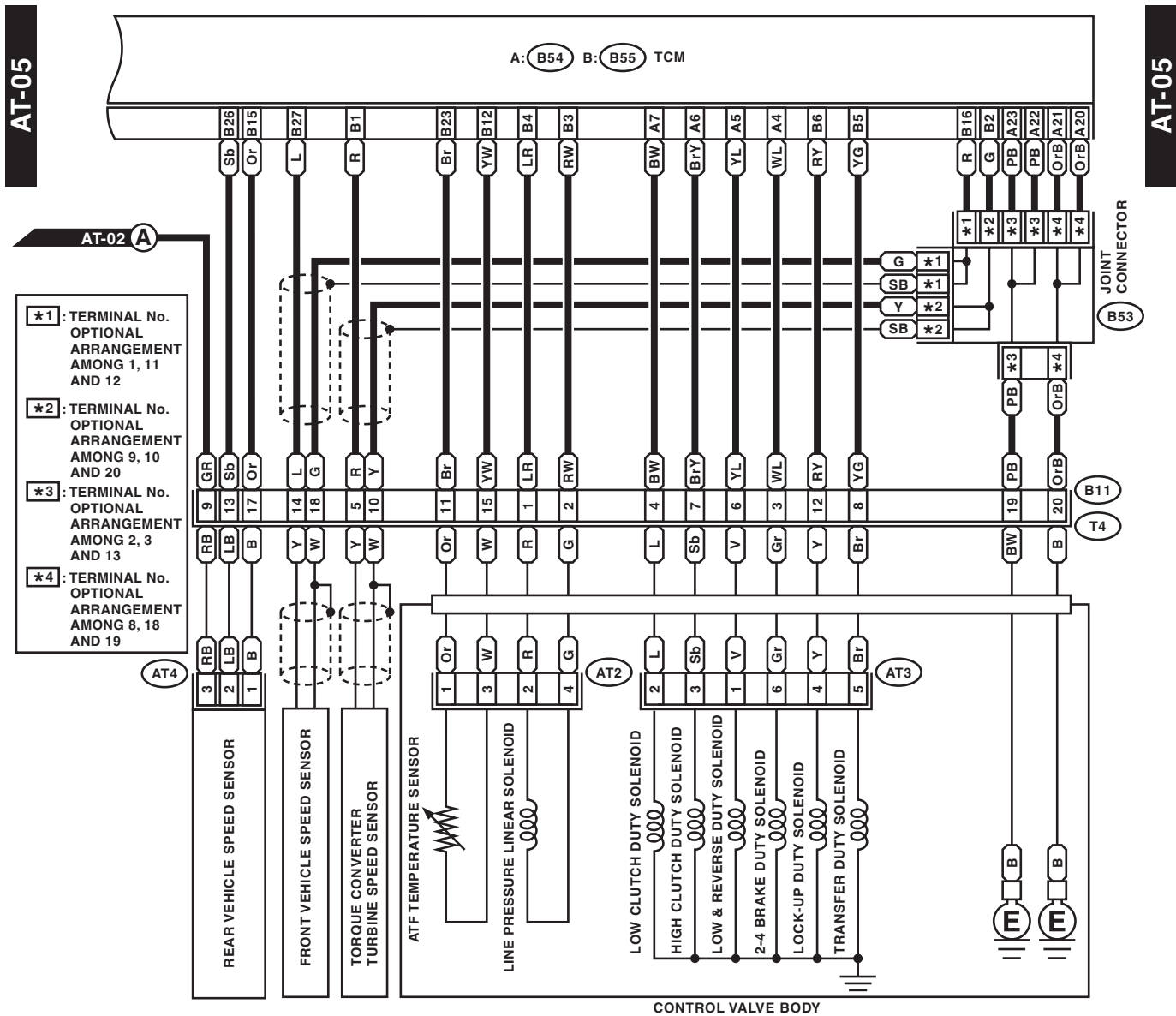

- \*1**: TERMINAL No. OPTIONAL ARRANGEMENT AMONG 1, 11 AND 12
- \*2**: TERMINAL No. OPTIONAL ARRANGEMENT AMONG 9, 10 AND 20
- \*3**: TERMINAL No. OPTIONAL ARRANGEMENT AMONG 2, 3 AND 13
- \*4**: TERMINAL No. OPTIONAL ARRANGEMENT AMONG 8, 18 AND 19

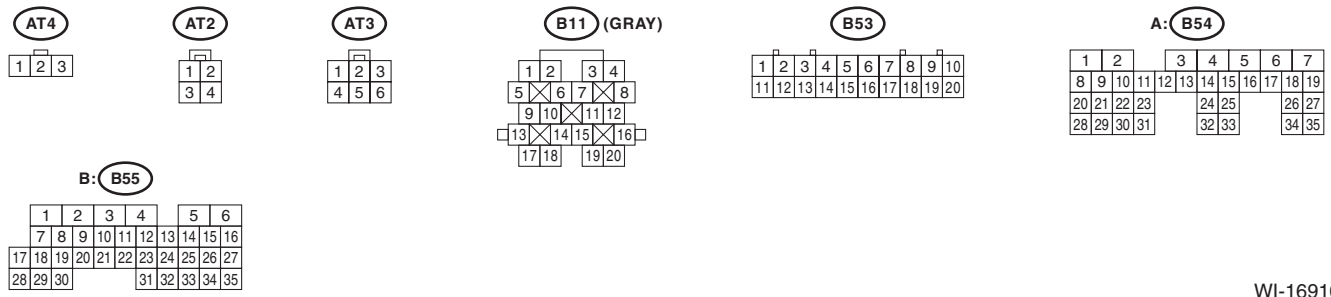

WI-16910

# AT Control System

WIRING SYSTEM

Brought to you by  
NOT FOR SALE  
Chris Studios

# AT Control System

Brought to you by Eris Studios  
NOT FOR RESALE

## WIRING SYSTEM

### 2. TRANSMISSION SERIAL NO. 3966775 OR LATER

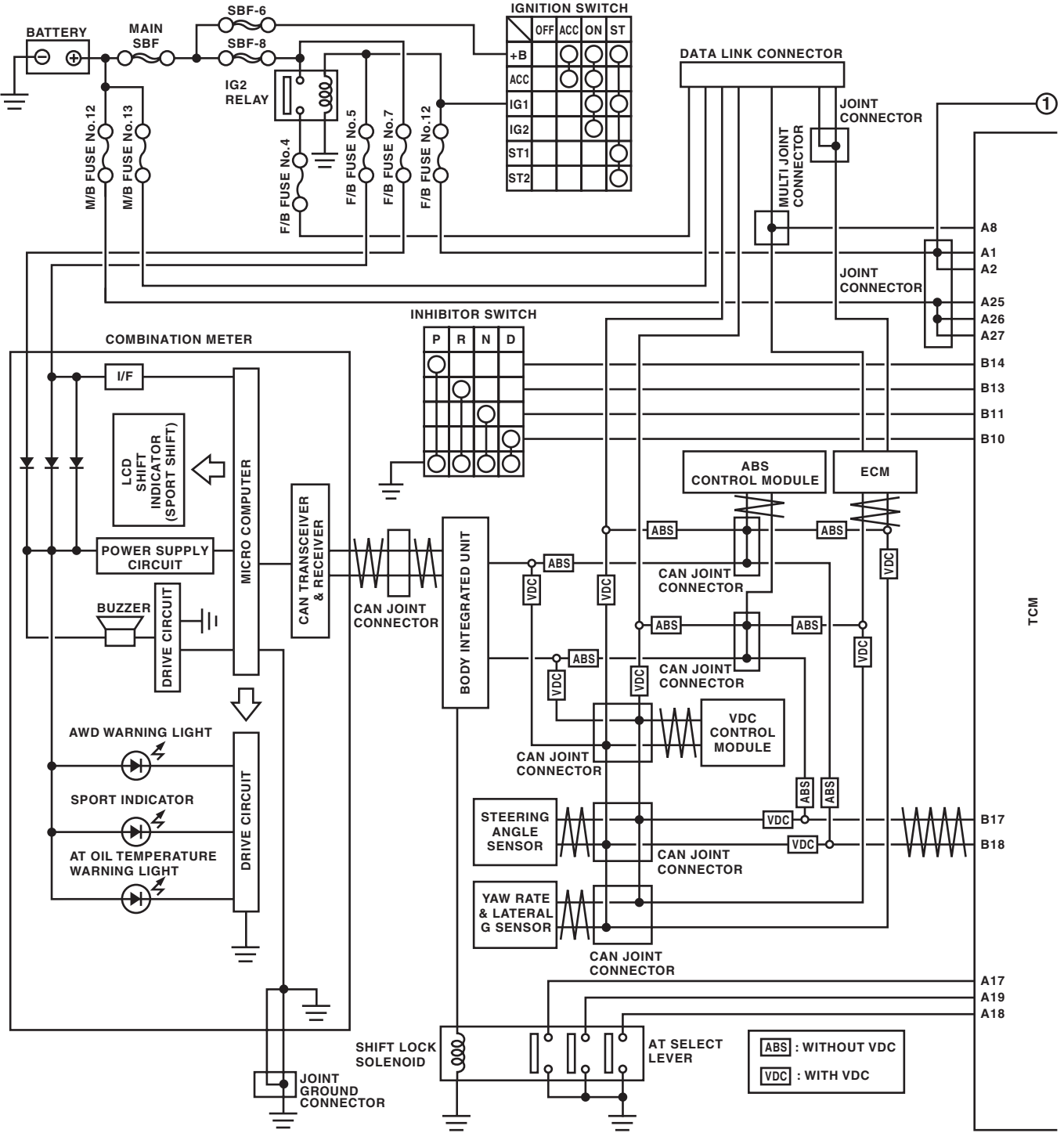

WI-16904

# AT Control System

## WIRING SYSTEM

Brought to you by *Chris Studios*  
NOT FOR SALE

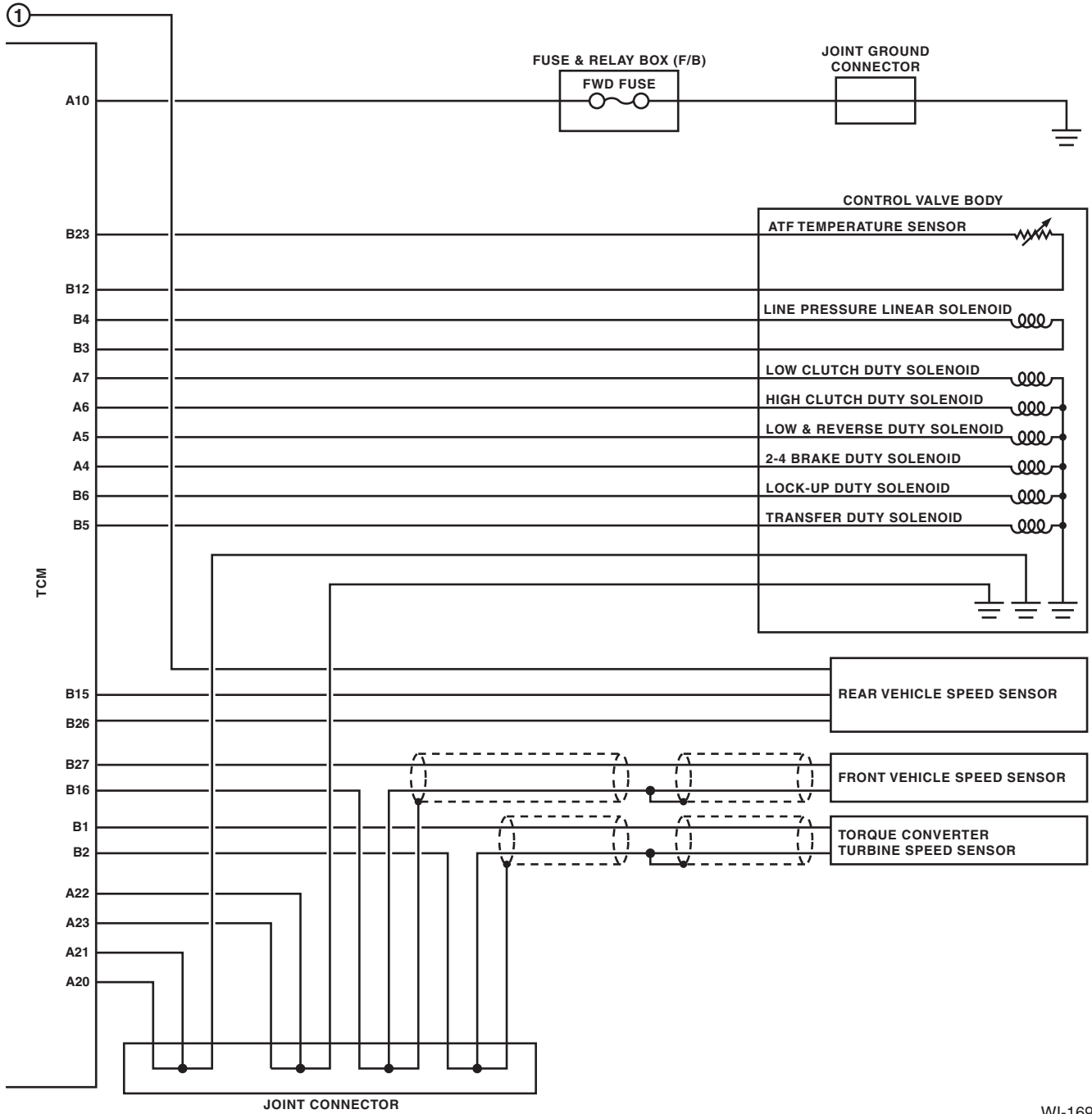

WI-16905

# AT Control System

Brought to you by Eris Studios  
NOT FOR RESALE

## WIRING SYSTEM

AT-01

AT-01

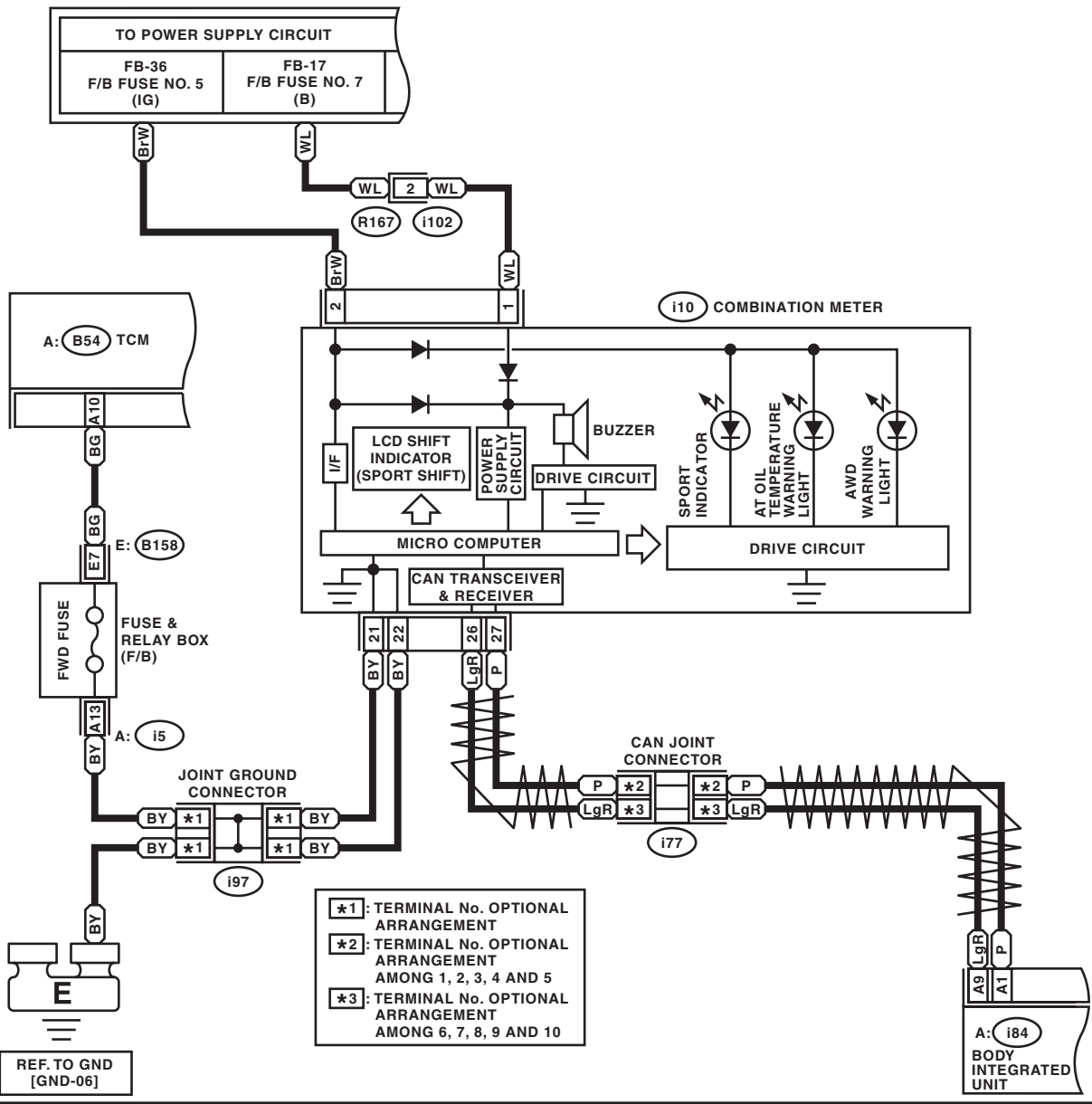

- \*1: TERMINAL No. OPTIONAL ARRANGEMENT
- \*2: TERMINAL No. OPTIONAL ARRANGEMENT AMONG 1, 2, 3, 4 AND 5
- \*3: TERMINAL No. OPTIONAL ARRANGEMENT AMONG 6, 7, 8, 9 AND 10

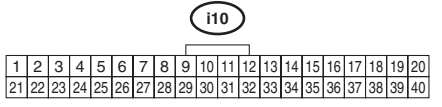
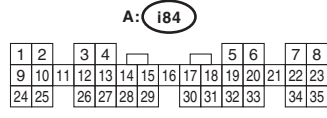
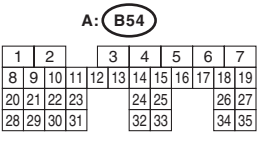
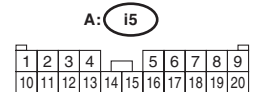
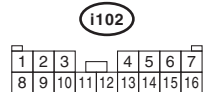
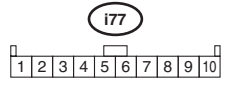
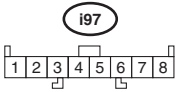

WI-16906

# AT Control System

## WIRING SYSTEM

Brought to you by *Chris Studios*  
 NOT FOR SALE

AT-02

AT-02

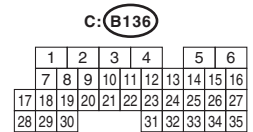
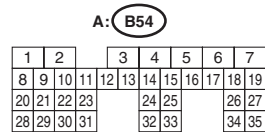
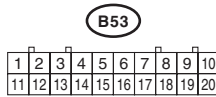
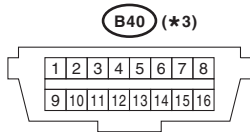
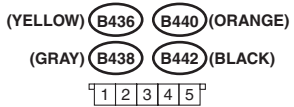
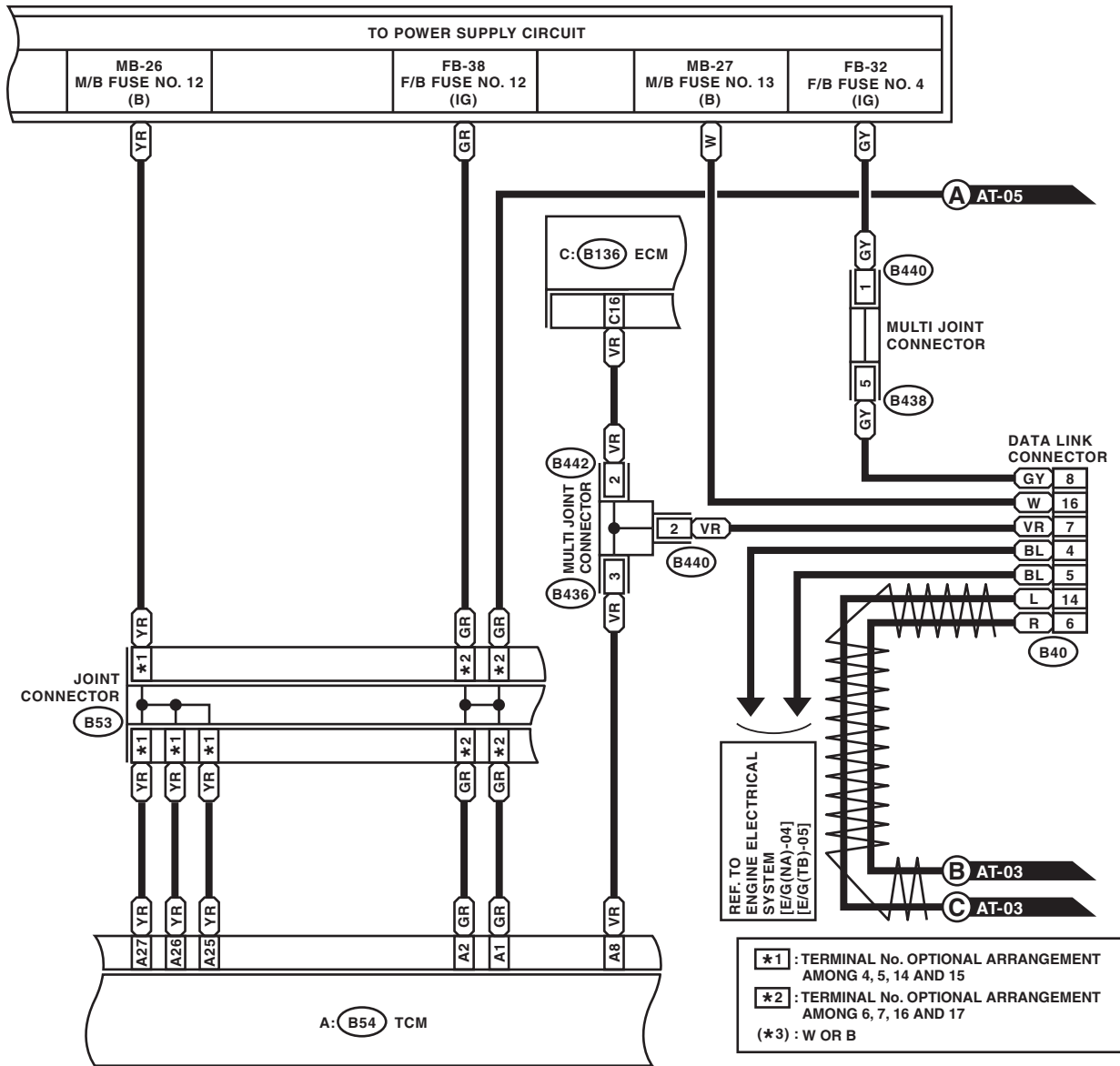

WI-18765

# AT Control System

Brought to you by Eris Studios  
NOT FOR RESALE

## WIRING SYSTEM

AT-03

ABS : WITHOUT VDC  
VDC : WITH VDC

AT-03

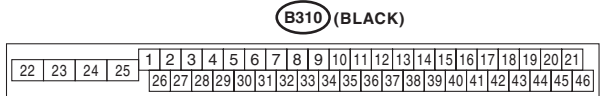
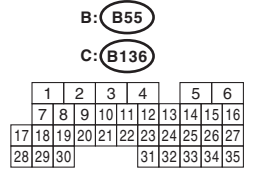
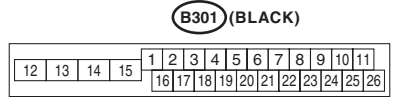
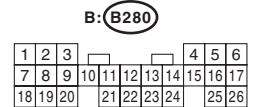
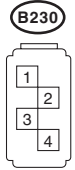
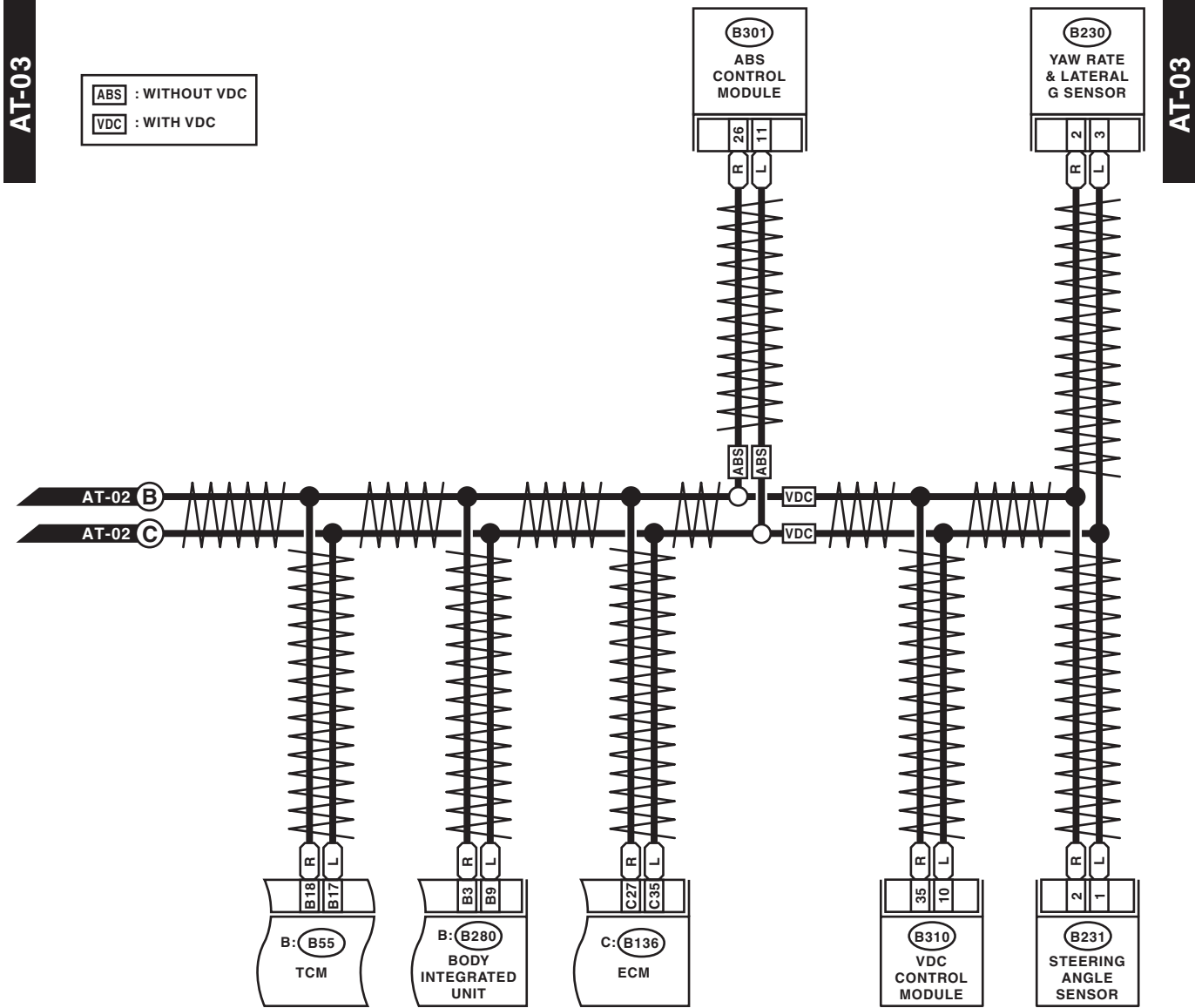

WI-16908



# AT Control System

## WIRING SYSTEM

Brought to you by *Chris Studios*  
 NOT FOR SALE

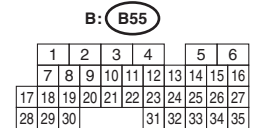
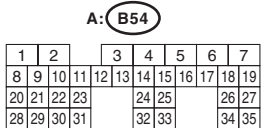
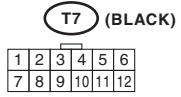
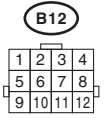
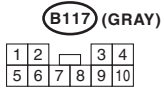
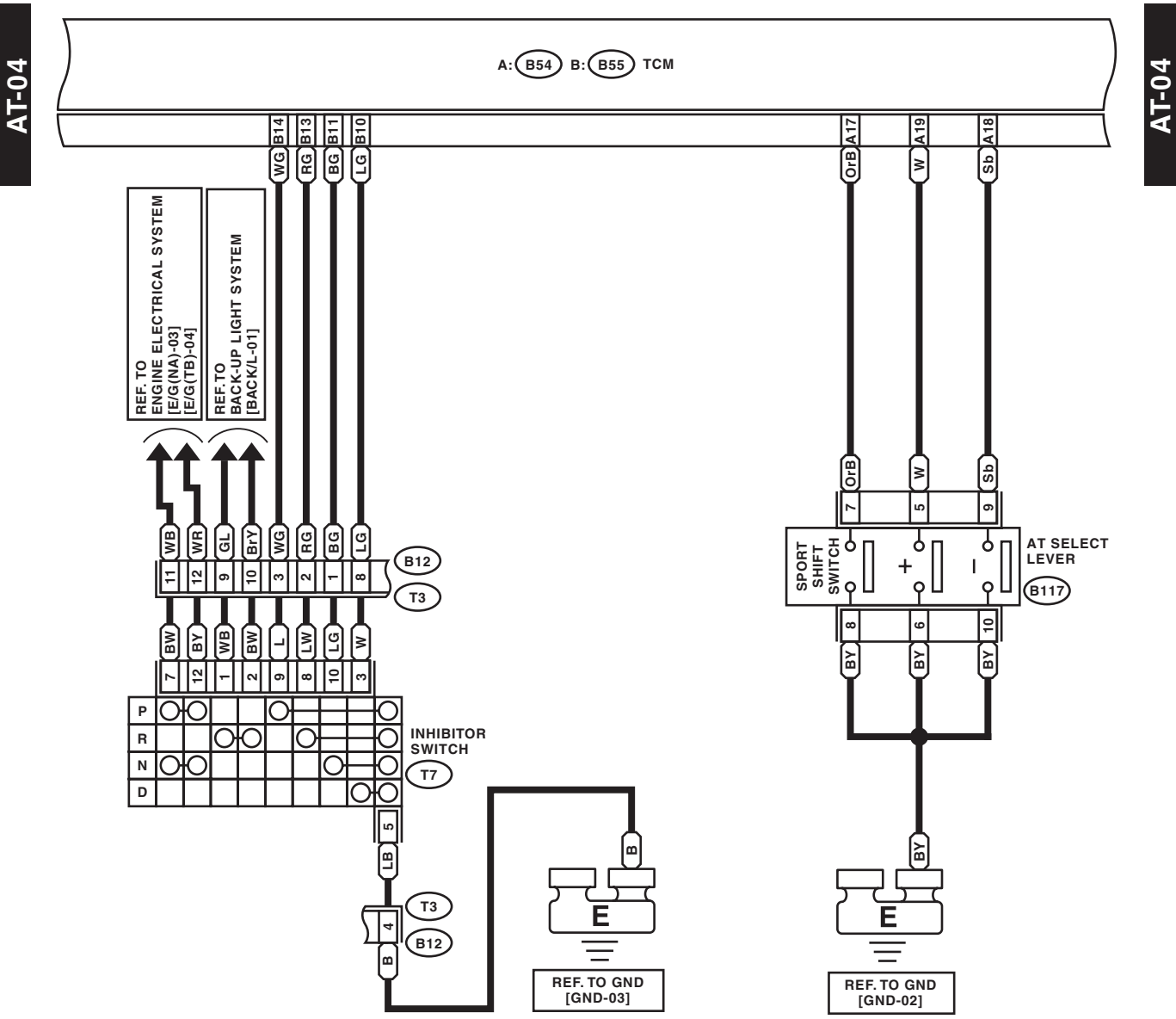

WI-16909

# AT Control System

Brought to you by Eris Studios  
NOT FOR RESALE

## WIRING SYSTEM

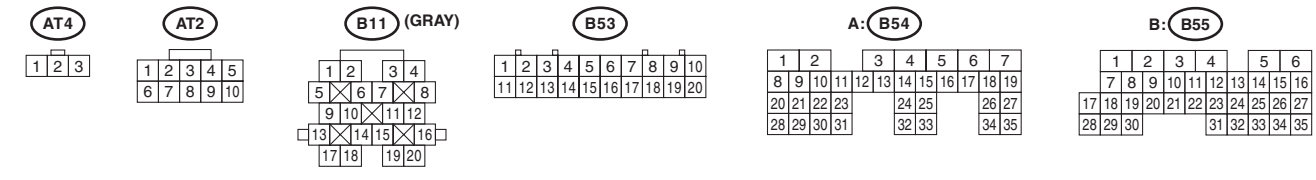
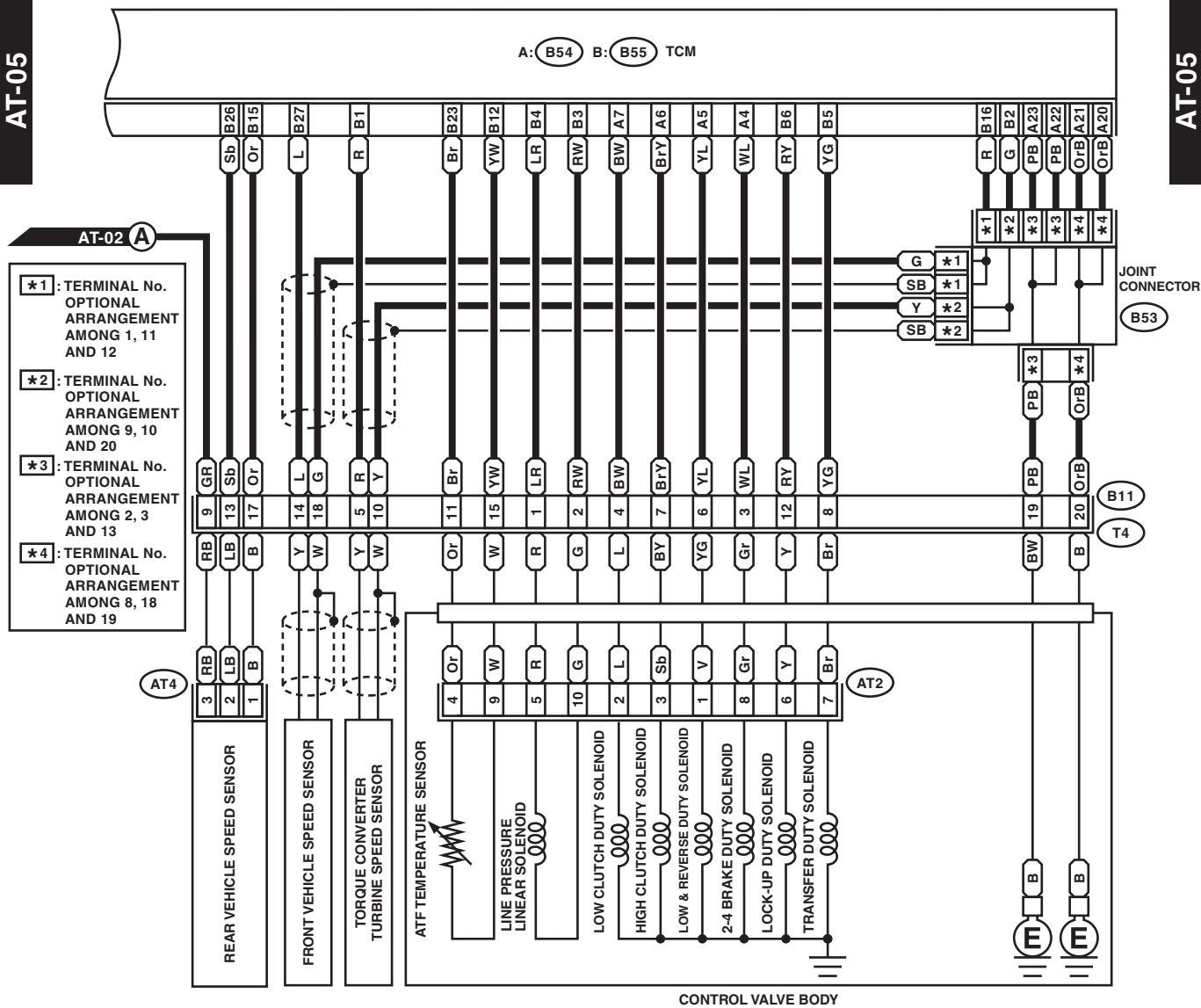

WI-19670

# AT Control System

WIRING SYSTEM

Brought to you by  
NOT FOR SALE  
Chris Studios

# AT Control System

Brought to you by Eris Studios  
NOT FOR RESALE

## WIRING SYSTEM

### 3. TRANSMISSION SERIAL NO. 4078113 OR LATER

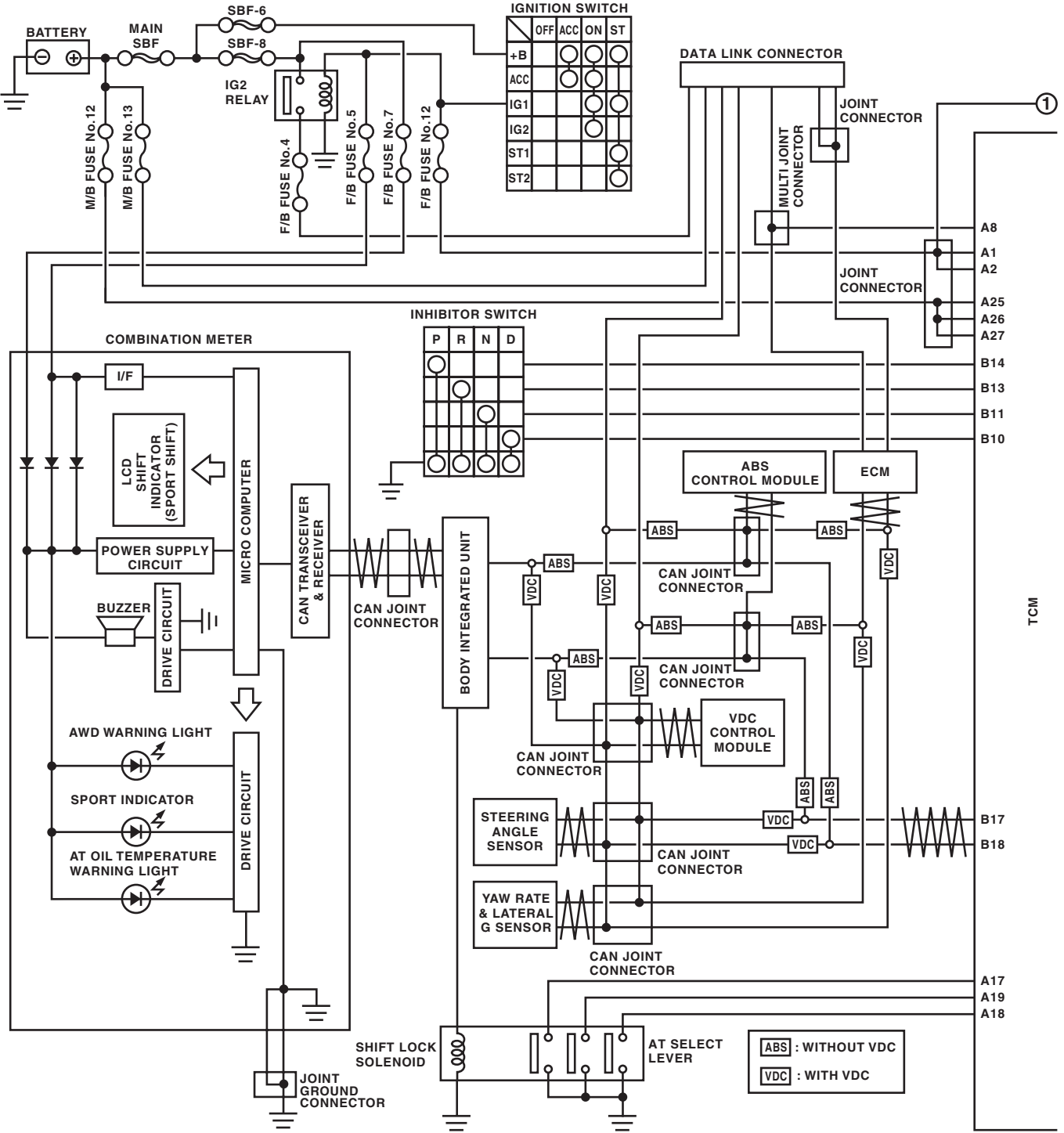

WI-16904

# AT Control System

## WIRING SYSTEM

Brought to you by  
NOVUS  
SALES  
Chris Studios

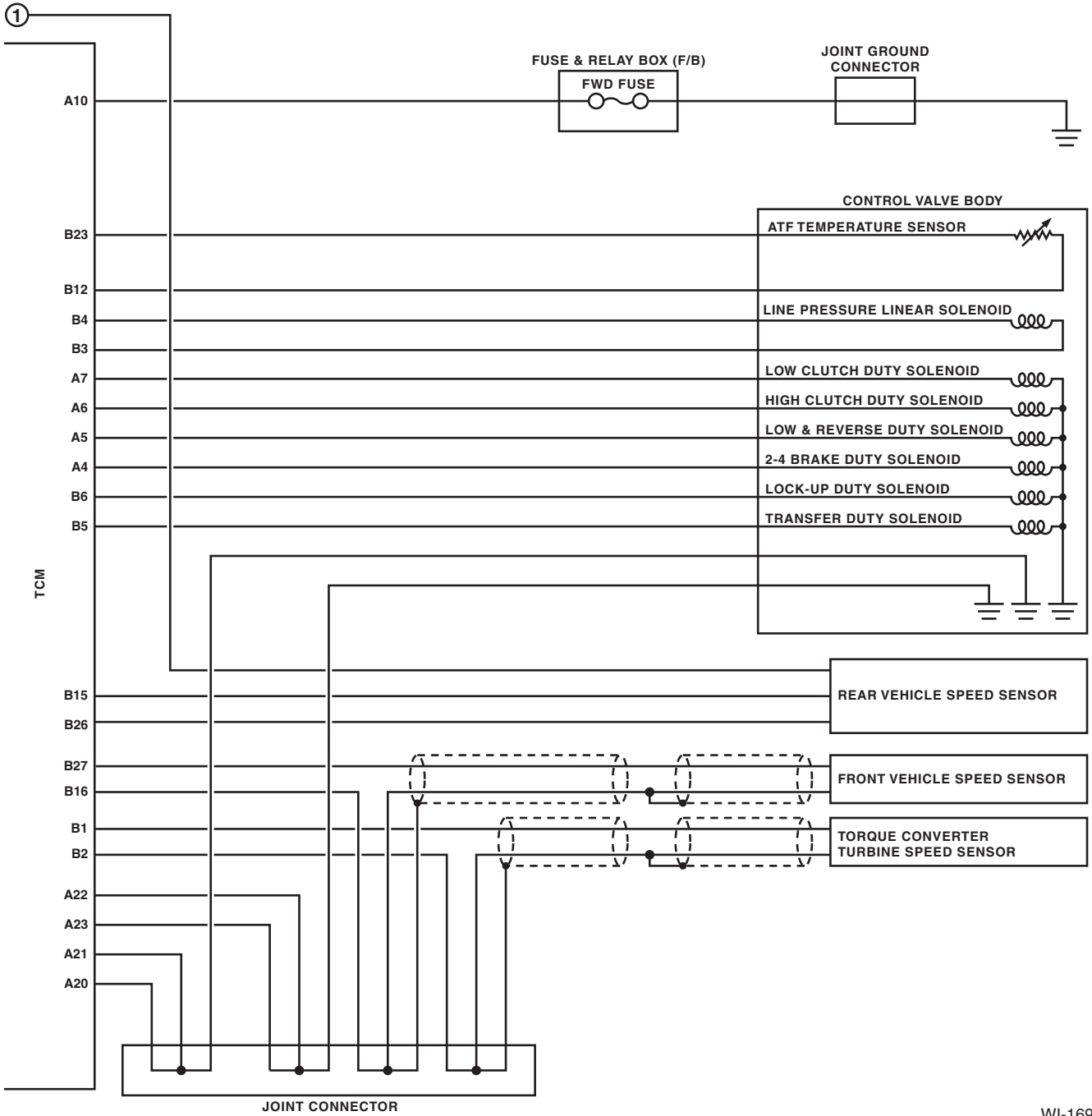

WI-16905

# AT Control System

Brought to you by Eris Studios  
NOT FOR RESALE

## WIRING SYSTEM

AT-01

AT-01

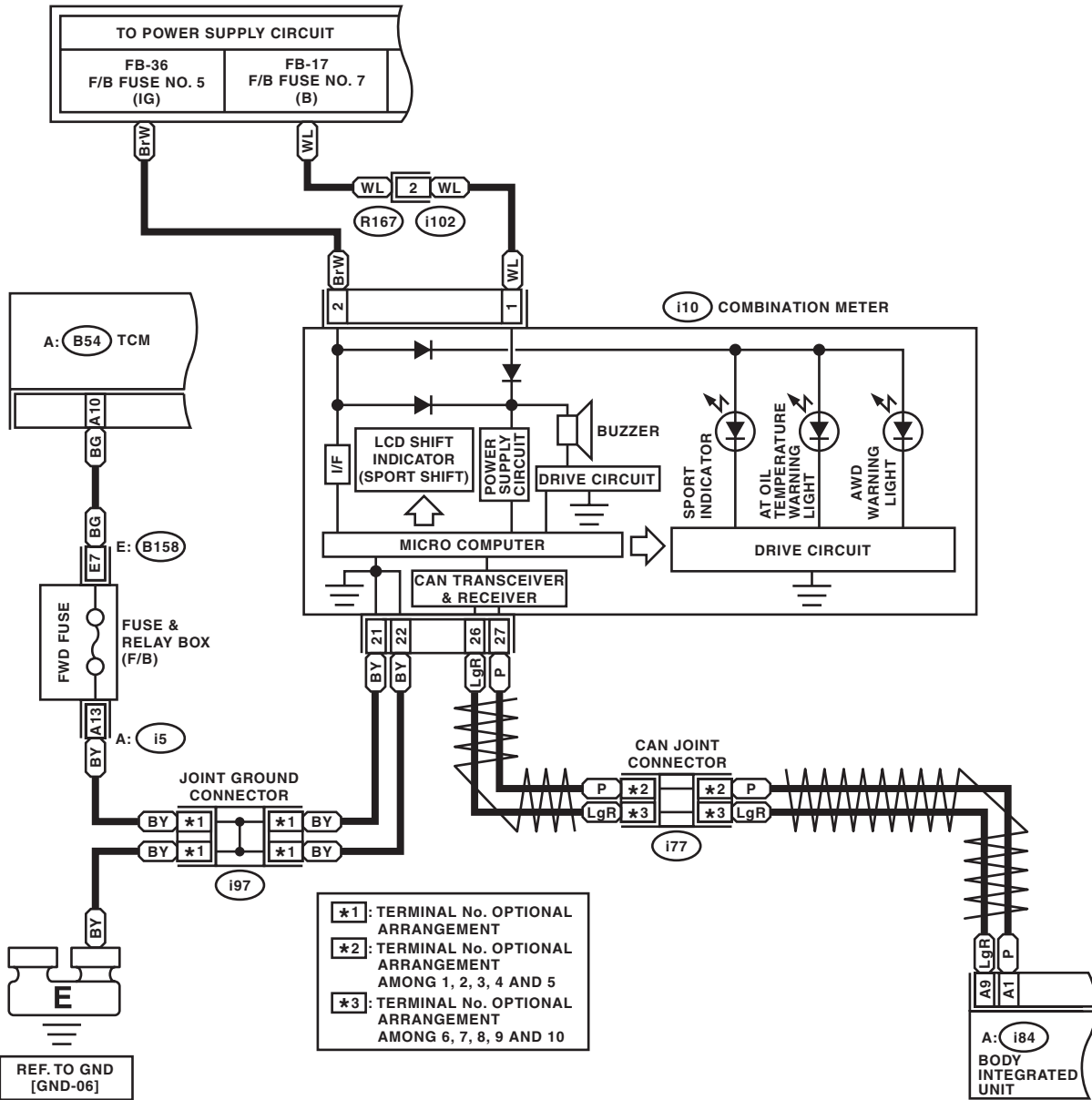

- \*1: TERMINAL No. OPTIONAL ARRANGEMENT
- \*2: TERMINAL No. OPTIONAL ARRANGEMENT AMONG 1, 2, 3, 4 AND 5
- \*3: TERMINAL No. OPTIONAL ARRANGEMENT AMONG 6, 7, 8, 9 AND 10

E: (B158)

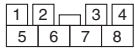

i97

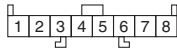

i77

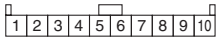

i102

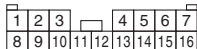

A: i5

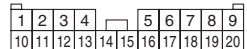

A: (B54)

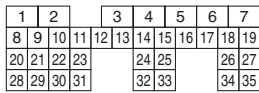

A: (i84)

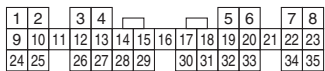

i10

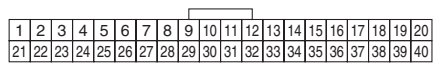

WI-16906

# AT Control System

## WIRING SYSTEM

Brought to you by *Chris Studios*  
 NOT FOR SALE

AT-02

AT-02

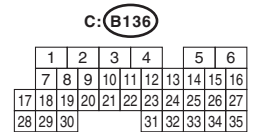
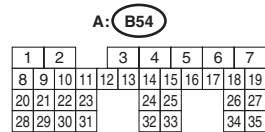
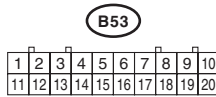
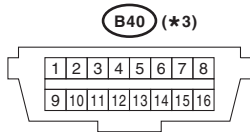
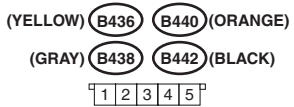
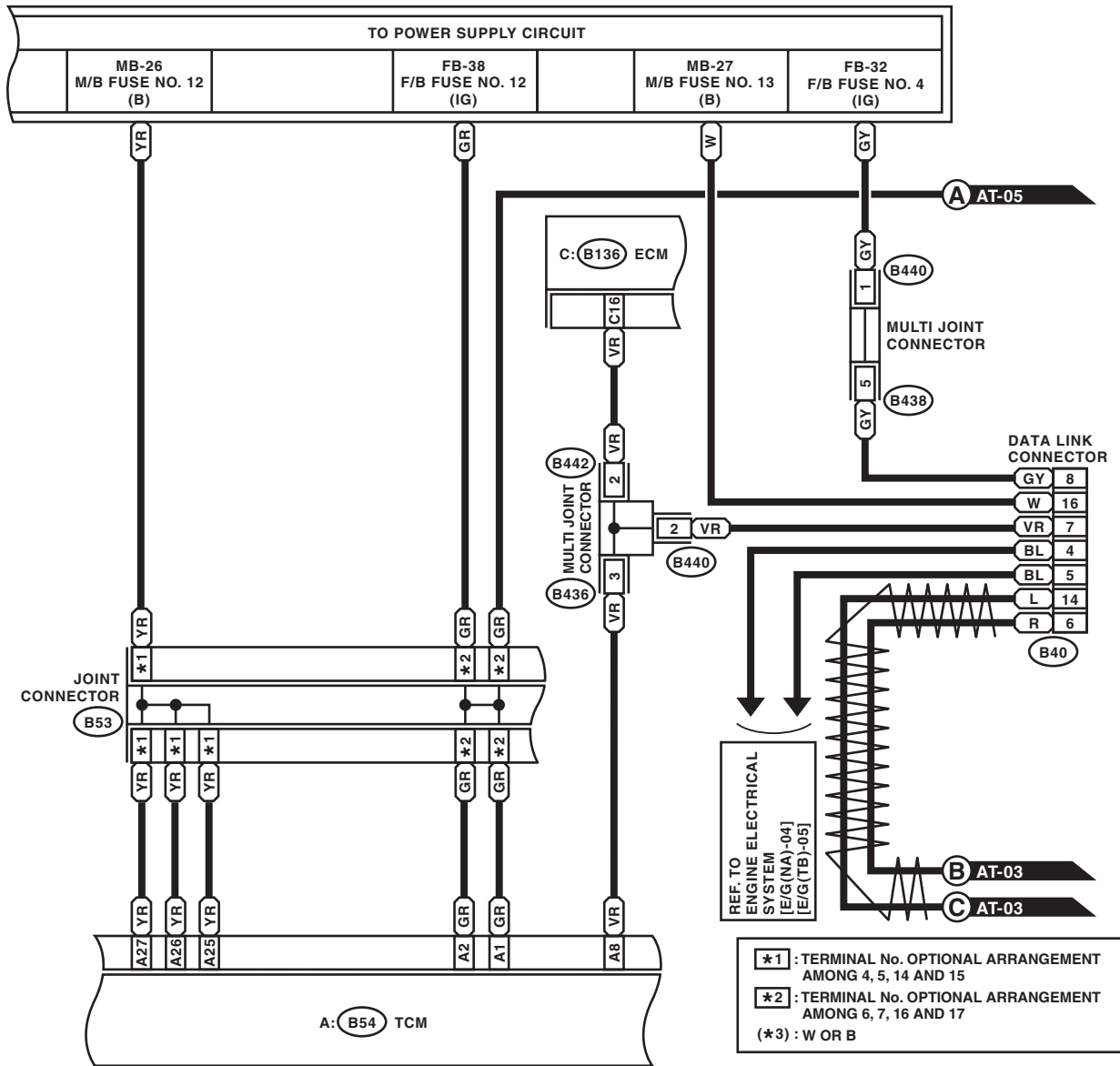

WI-18765

# AT Control System

Brought to you by Eris Studios  
NOT FOR RESALE

## WIRING SYSTEM

AT-03

ABS : WITHOUT VDC  
VDC : WITH VDC

AT-03

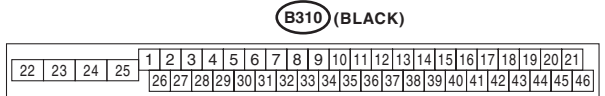
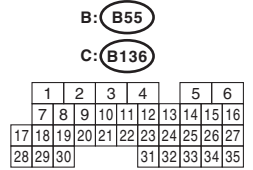
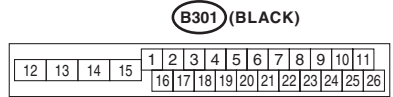
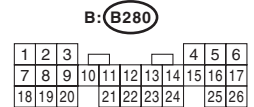
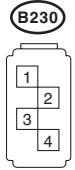
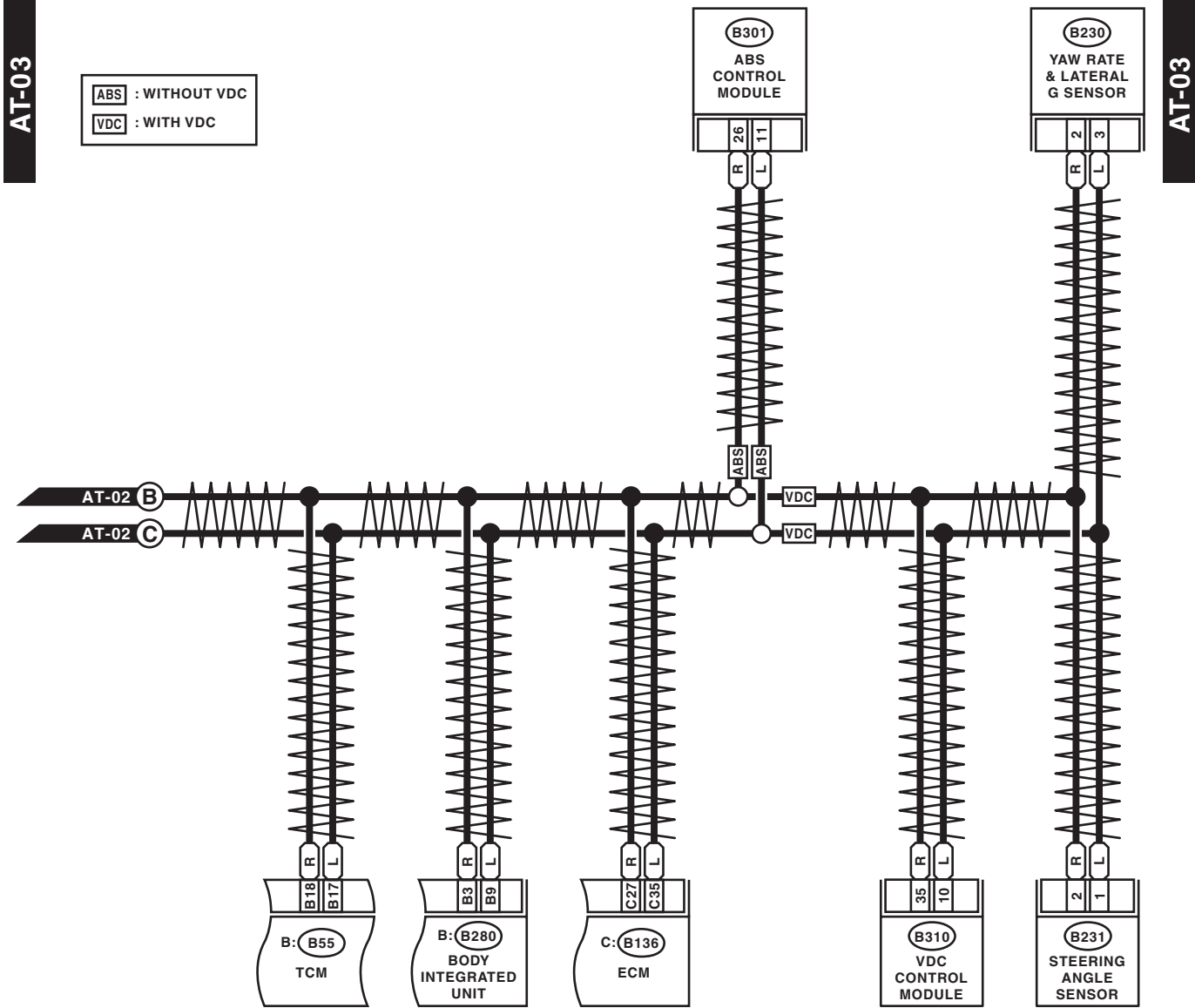

WI-16908



# AT Control System

## WIRING SYSTEM

Brought to you by *Chris Studios*  
 NO COPYRIGHT SALE

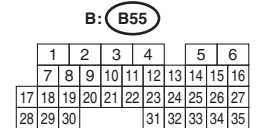
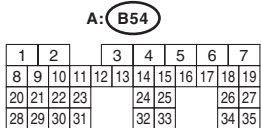
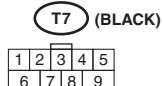
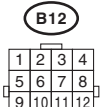
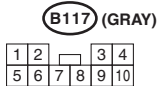
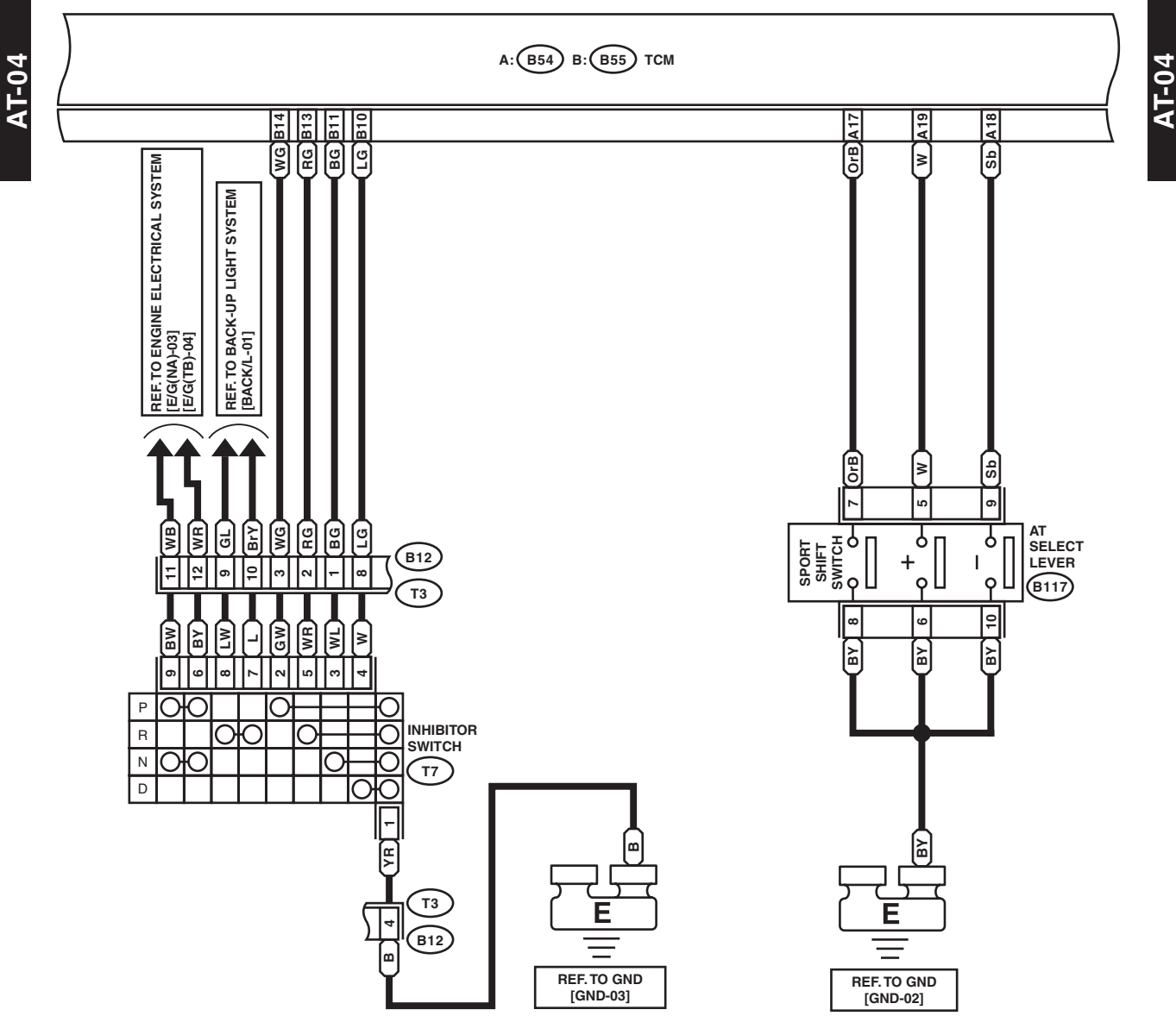

WI-21045

# AT Control System

Brought to you by Eris Studios  
NOT FOR RESALE

## WIRING SYSTEM

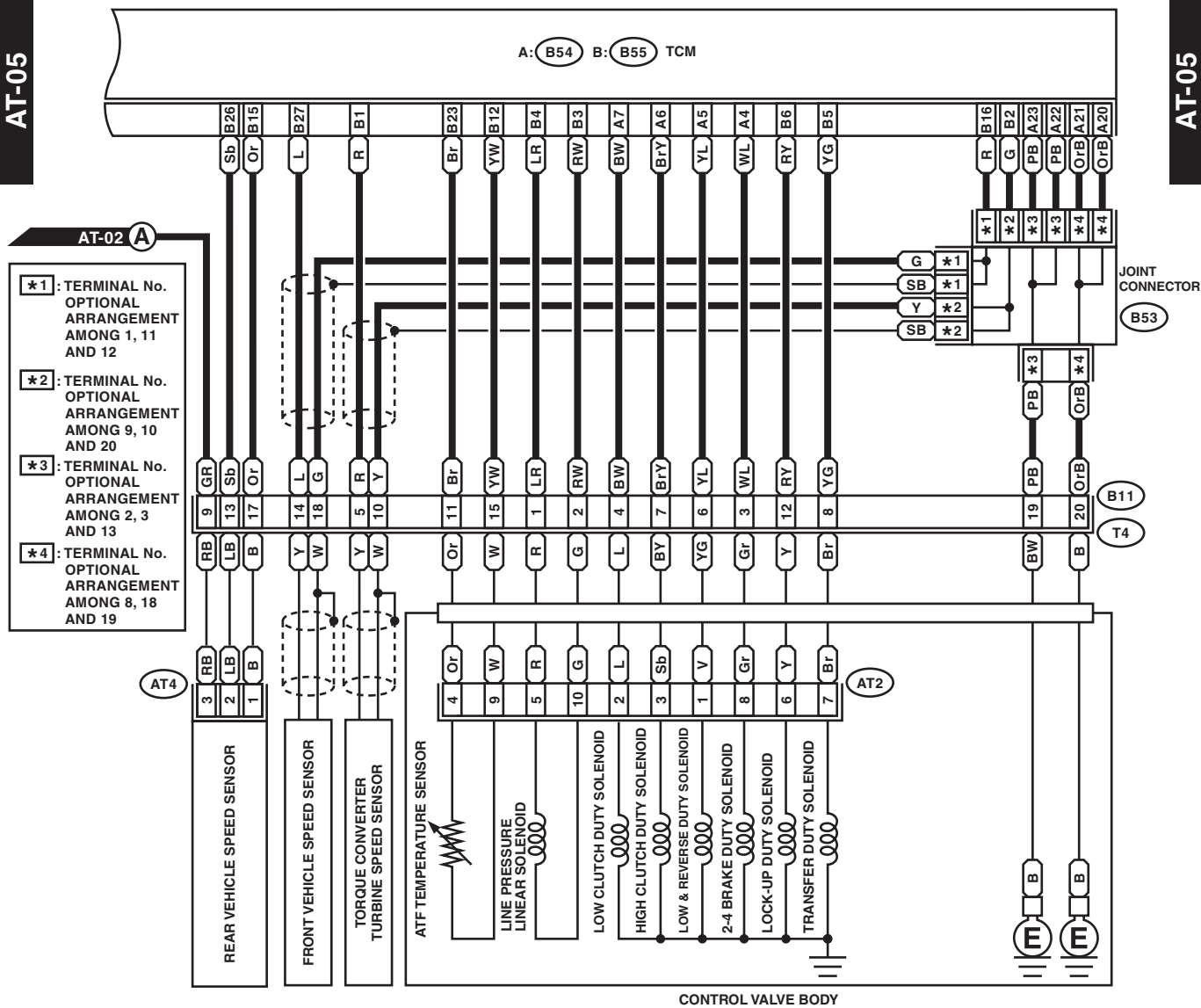

- \*1: TERMINAL No. OPTIONAL ARRANGEMENT AMONG 1, 11 AND 12
- \*2: TERMINAL No. OPTIONAL ARRANGEMENT AMONG 9, 10 AND 20
- \*3: TERMINAL No. OPTIONAL ARRANGEMENT AMONG 2, 3 AND 13
- \*4: TERMINAL No. OPTIONAL ARRANGEMENT AMONG 8, 18 AND 19

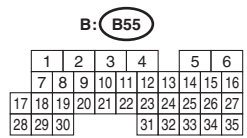
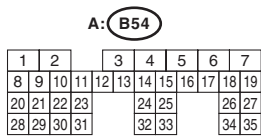
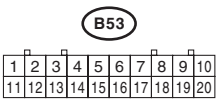
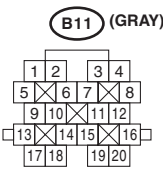
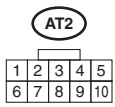

WI-19670

Brought to you by *Chris Studios*  
NOT FOR SALE

## 11. AT Shift Lock Control System

### A: WIRING DIAGRAM

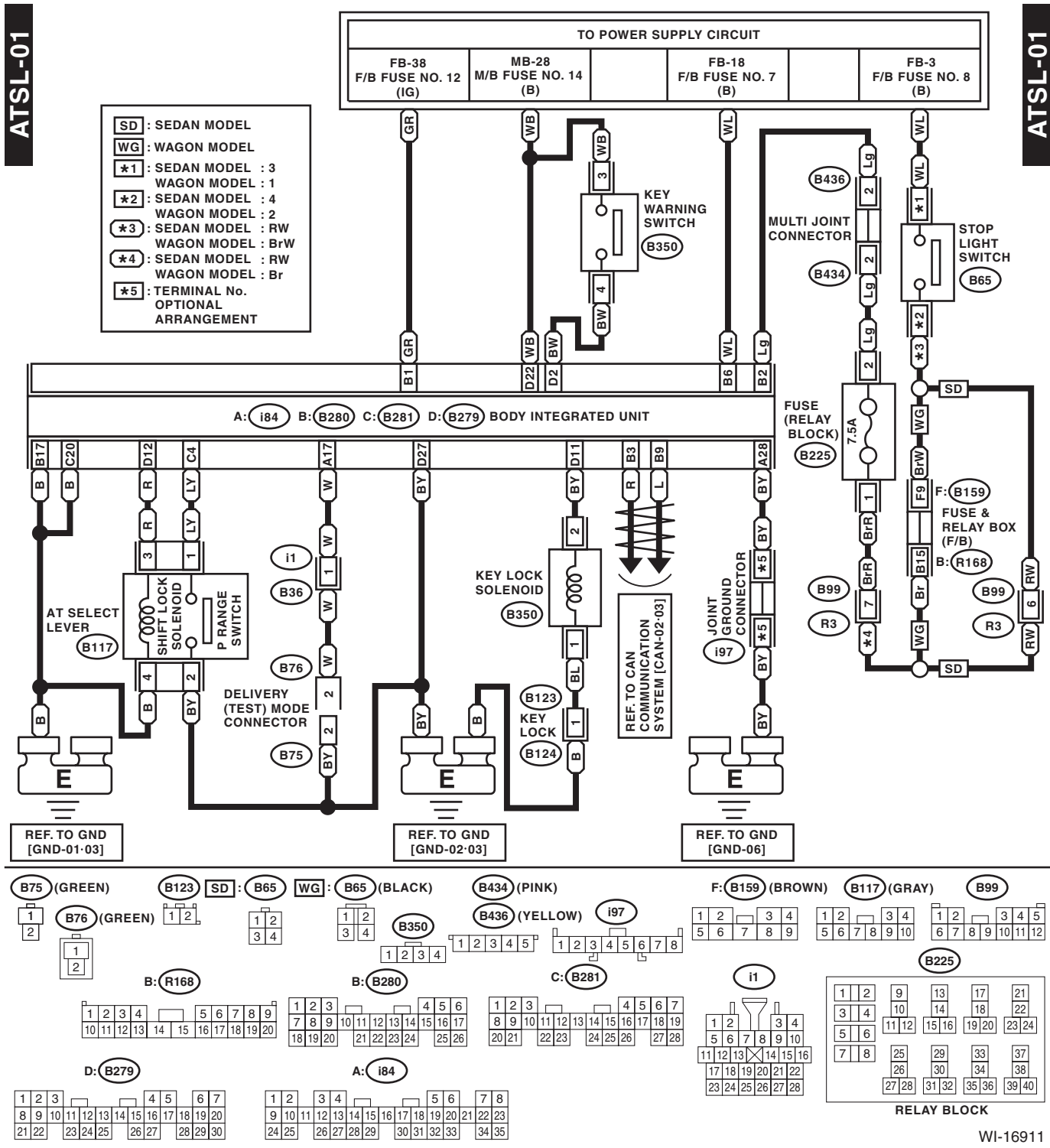

# Anti-lock Brake System

WIRING SYSTEM

Brought to you by Eris Studios  
NOT FOR RESALE

## 12. Anti-lock Brake System

### A: WIRING DIAGRAM

ABS-01

ABS-01

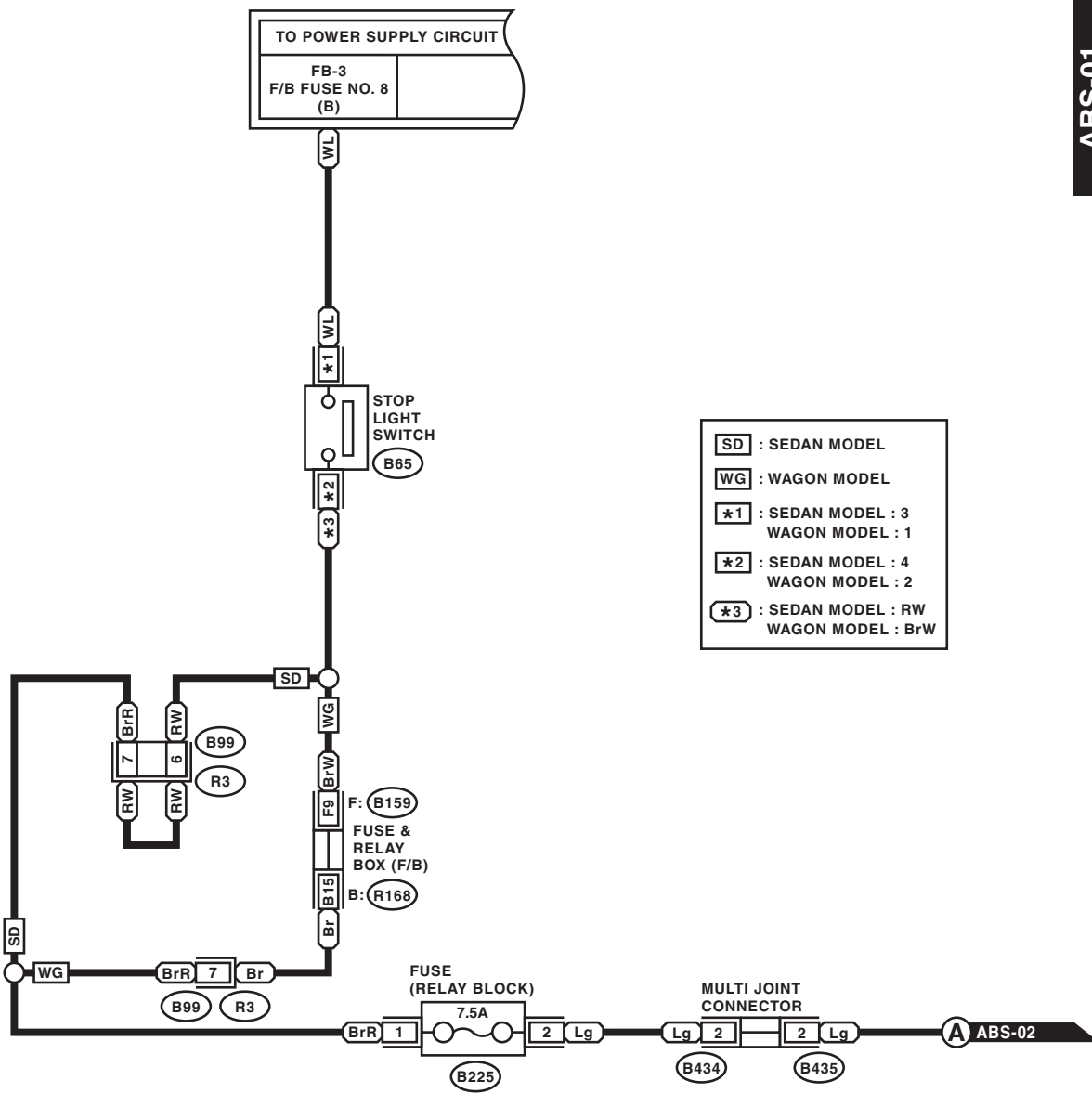

- SD** : SEDAN MODEL
- WG** : WAGON MODEL
- \*1** : SEDAN MODEL : 3  
WAGON MODEL : 1
- \*2** : SEDAN MODEL : 4  
WAGON MODEL : 2
- \*3** : SEDAN MODEL : RW  
WAGON MODEL : BrW

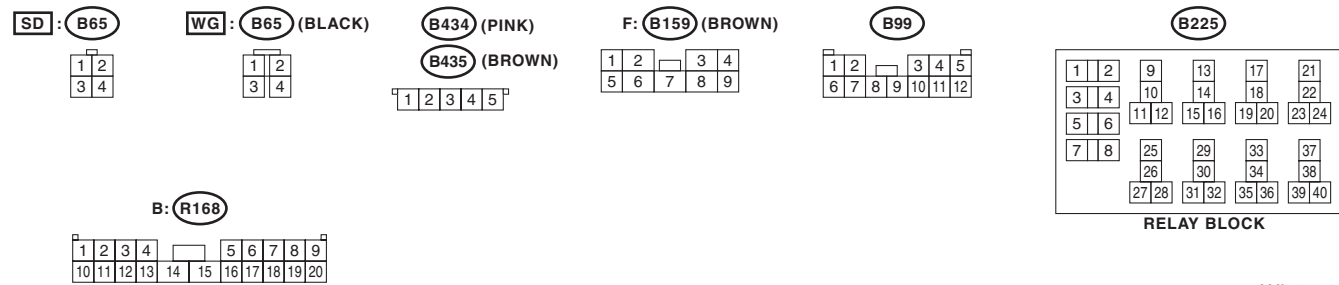

WI-16912

# Anti-lock Brake System

## WIRING SYSTEM

Brought to you by Pro Performance Studios  
 NOT FOR SALE

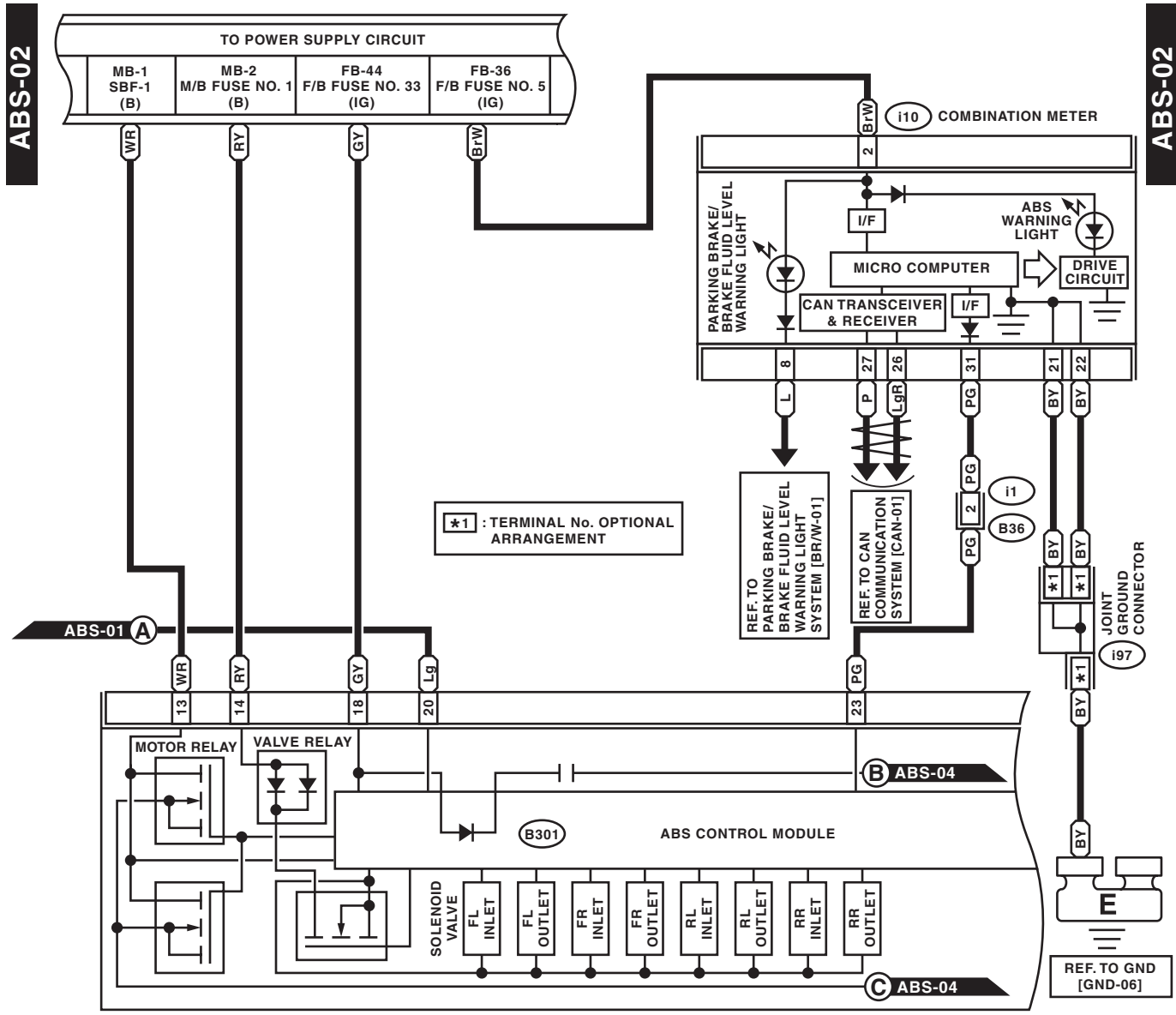

\*1 : TERMINAL No. OPTIONAL ARRANGEMENT

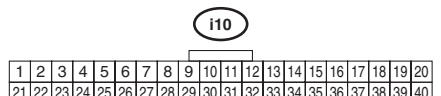
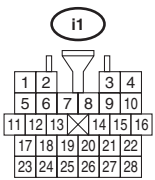
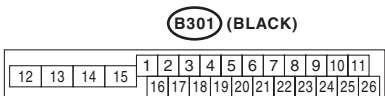
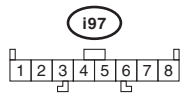

WI-16913

# Anti-lock Brake System

Brought to you by Eris Studios  
NOT FOR RESALE

## WIRING SYSTEM

ABS-03

ABS-03

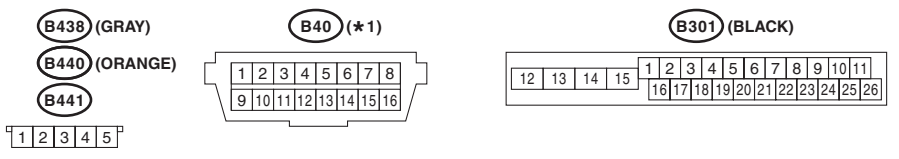
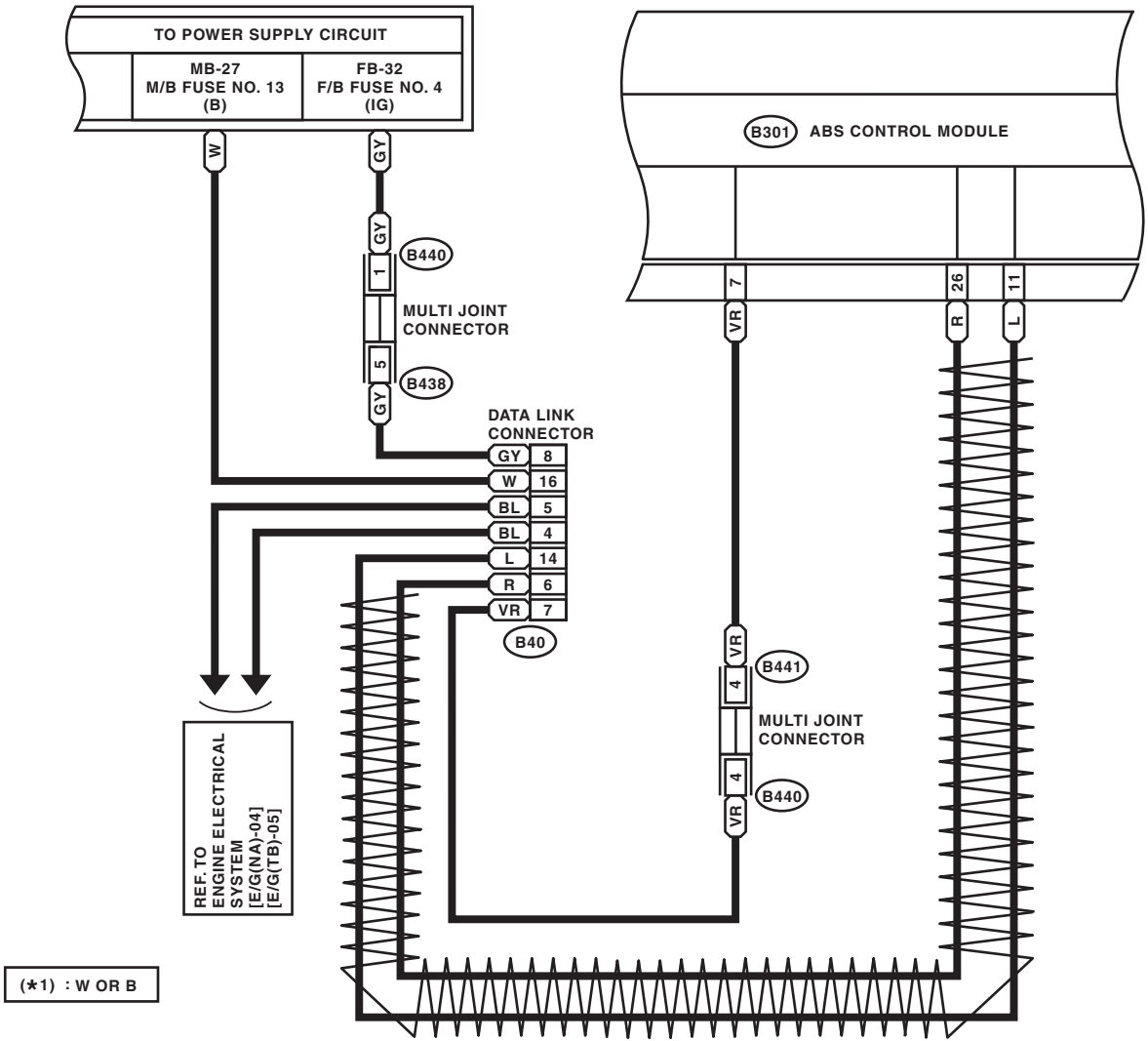

WI-18766

# Anti-lock Brake System

## WIRING SYSTEM

Brought to you by Chris Studios  
NOT FOR SALE

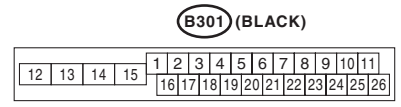
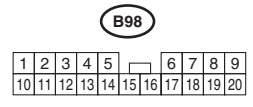
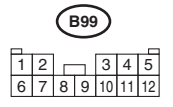
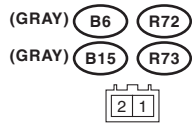
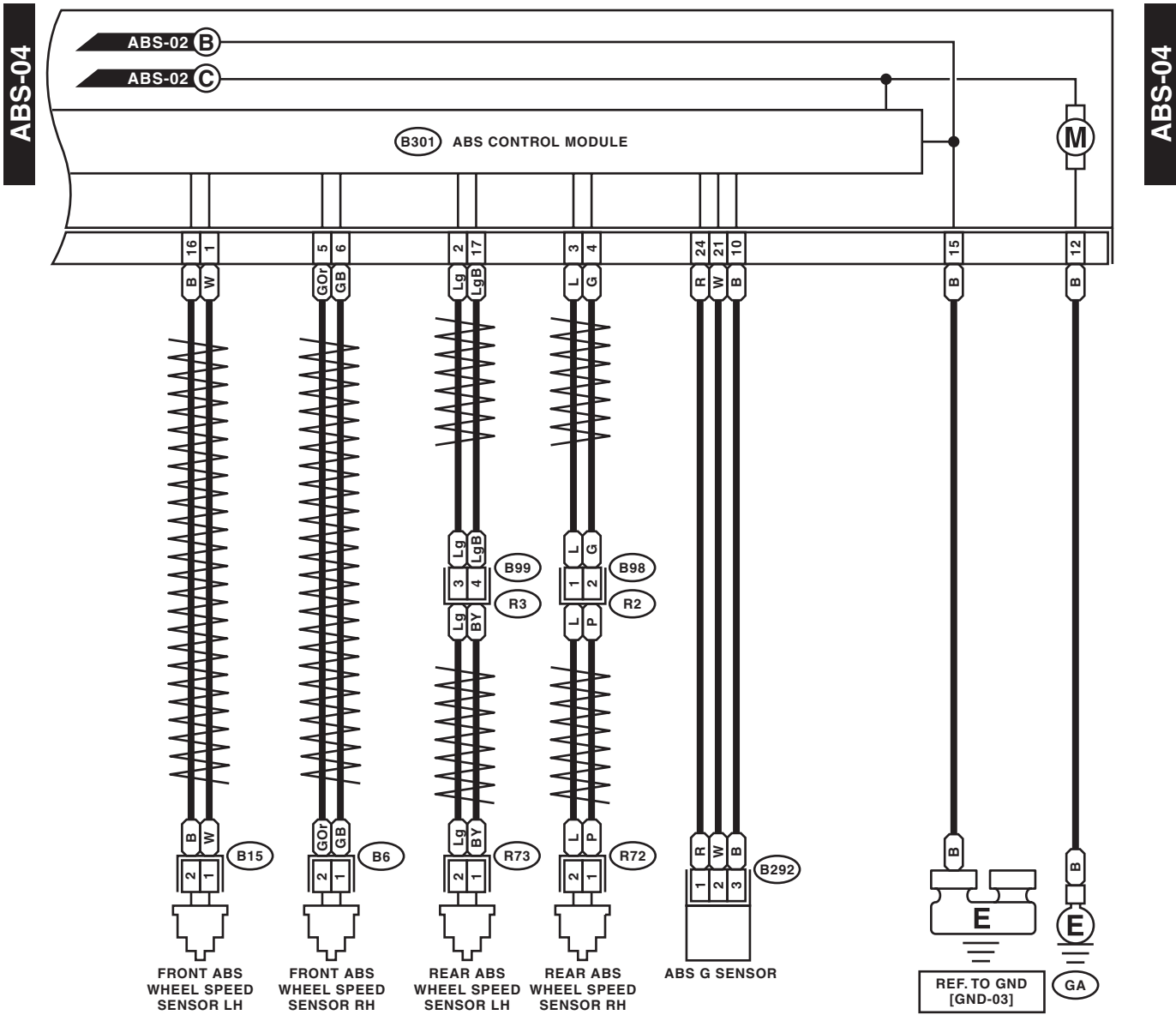

WI-16915

# Vehicle Dynamics Control System

WIRING SYSTEM

Brought to you by Eris Studios  
NOT FOR RESALE

## 13. Vehicle Dynamics Control System

### A: WIRING DIAGRAM

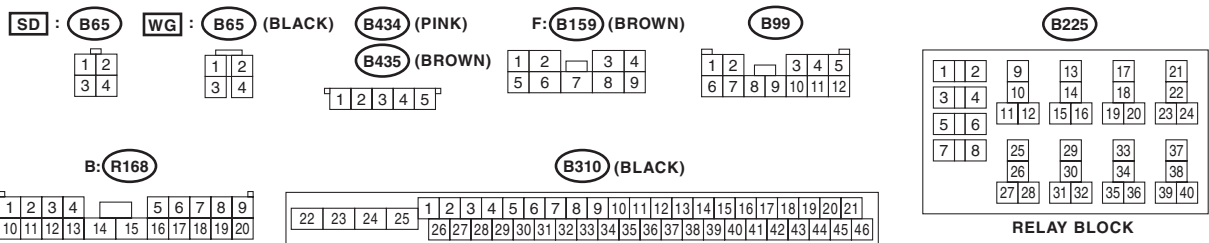
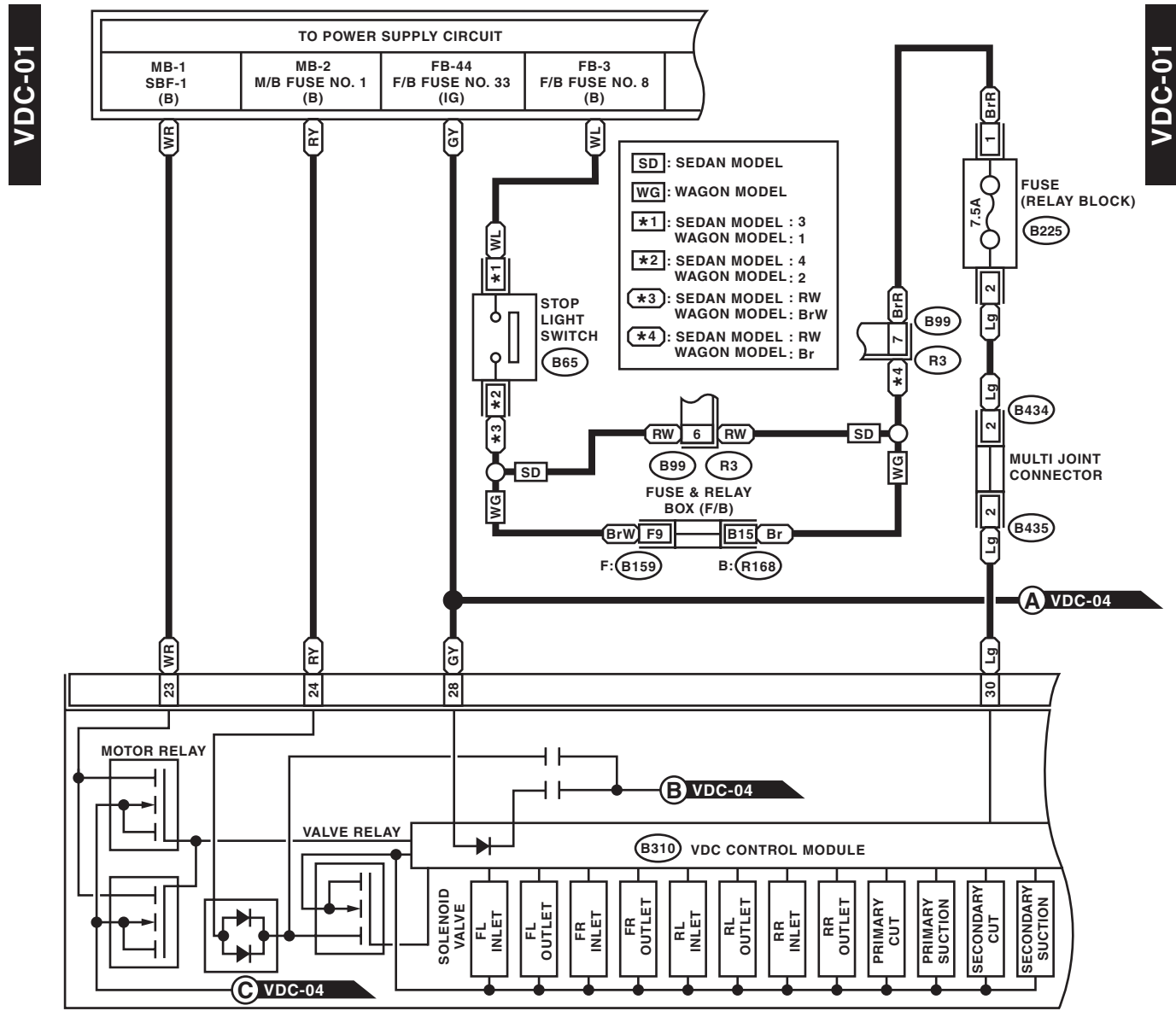

WI-16916



# Vehicle Dynamics Control System

## WIRING SYSTEM

Brought to you by *Chris Studios*  
NOT FOR SALE

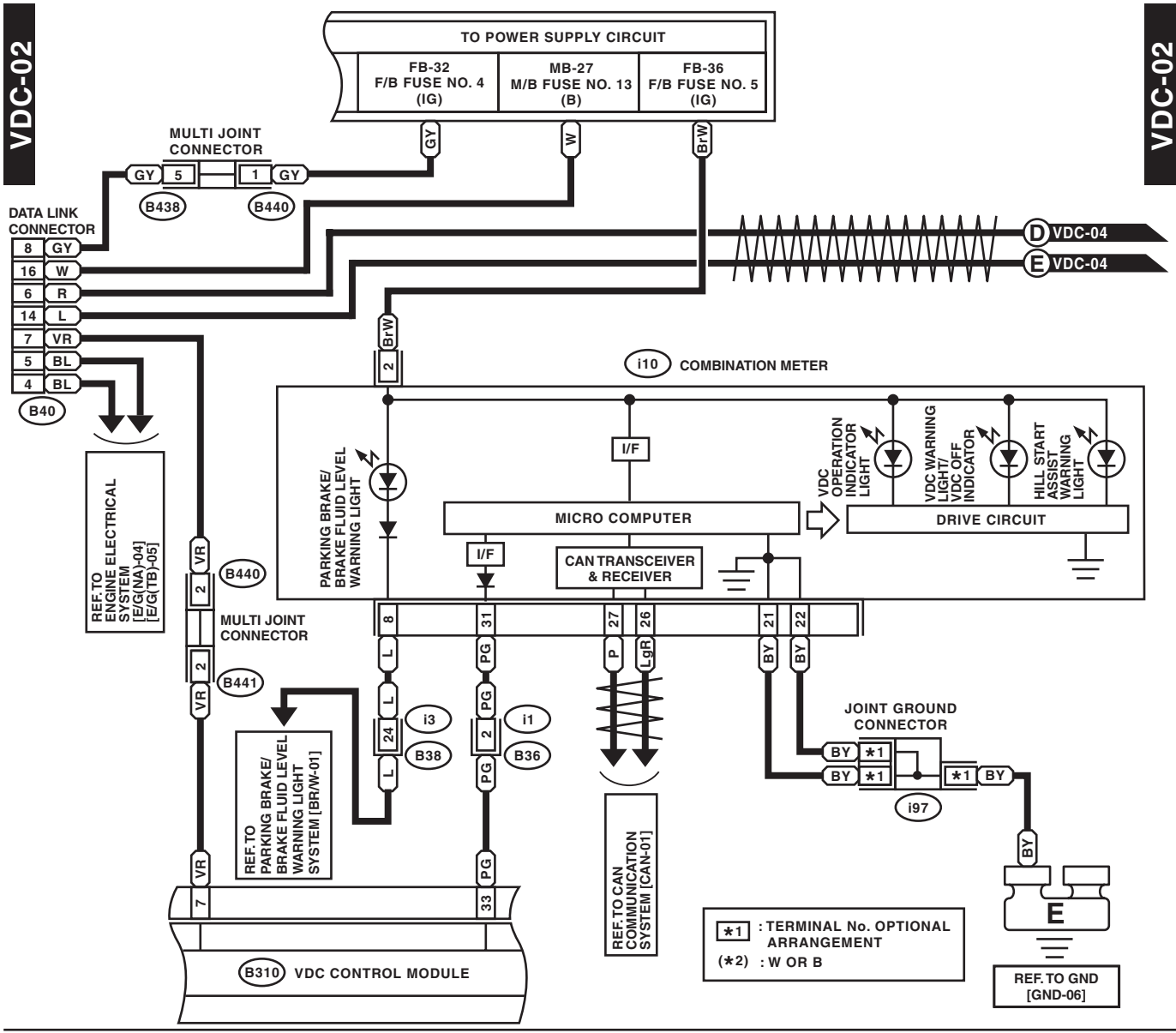

**VDC-02**

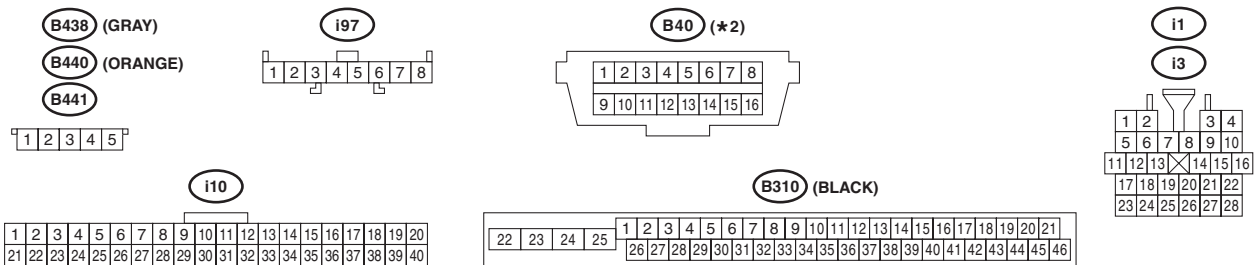

WI-18767

# Vehicle Dynamics Control System

WIRING SYSTEM

Brought to you by Eris Studios  
NOT FOR RESALE

VDC-03

VDC-03

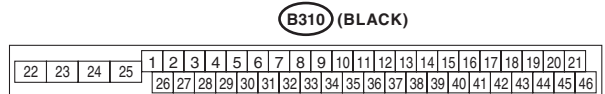
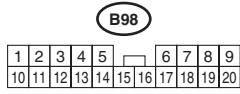
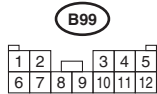
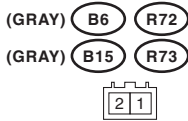
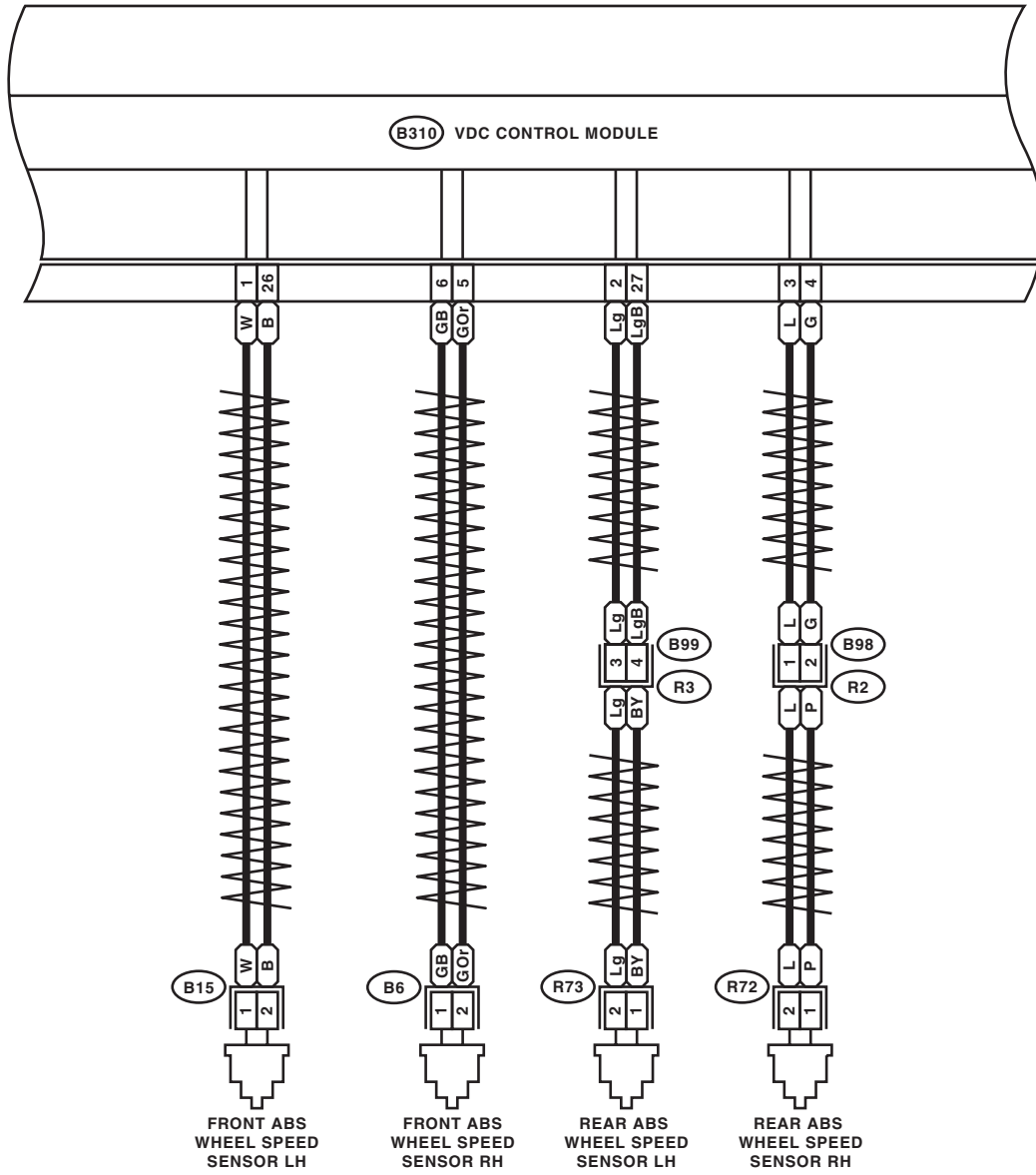

WI-16918

# Vehicle Dynamics Control System

## WIRING SYSTEM

Brought to you by *Chris Studios*  
 NOT FOR SALE

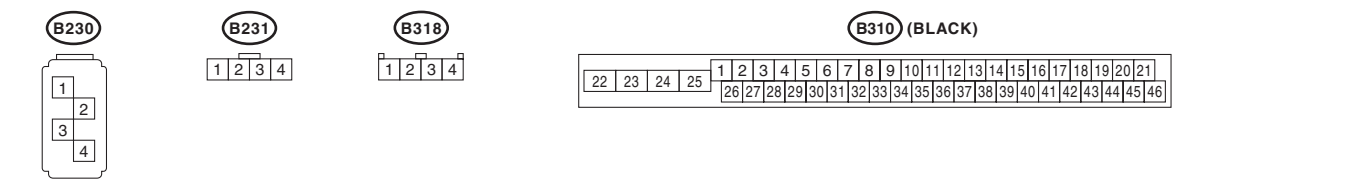
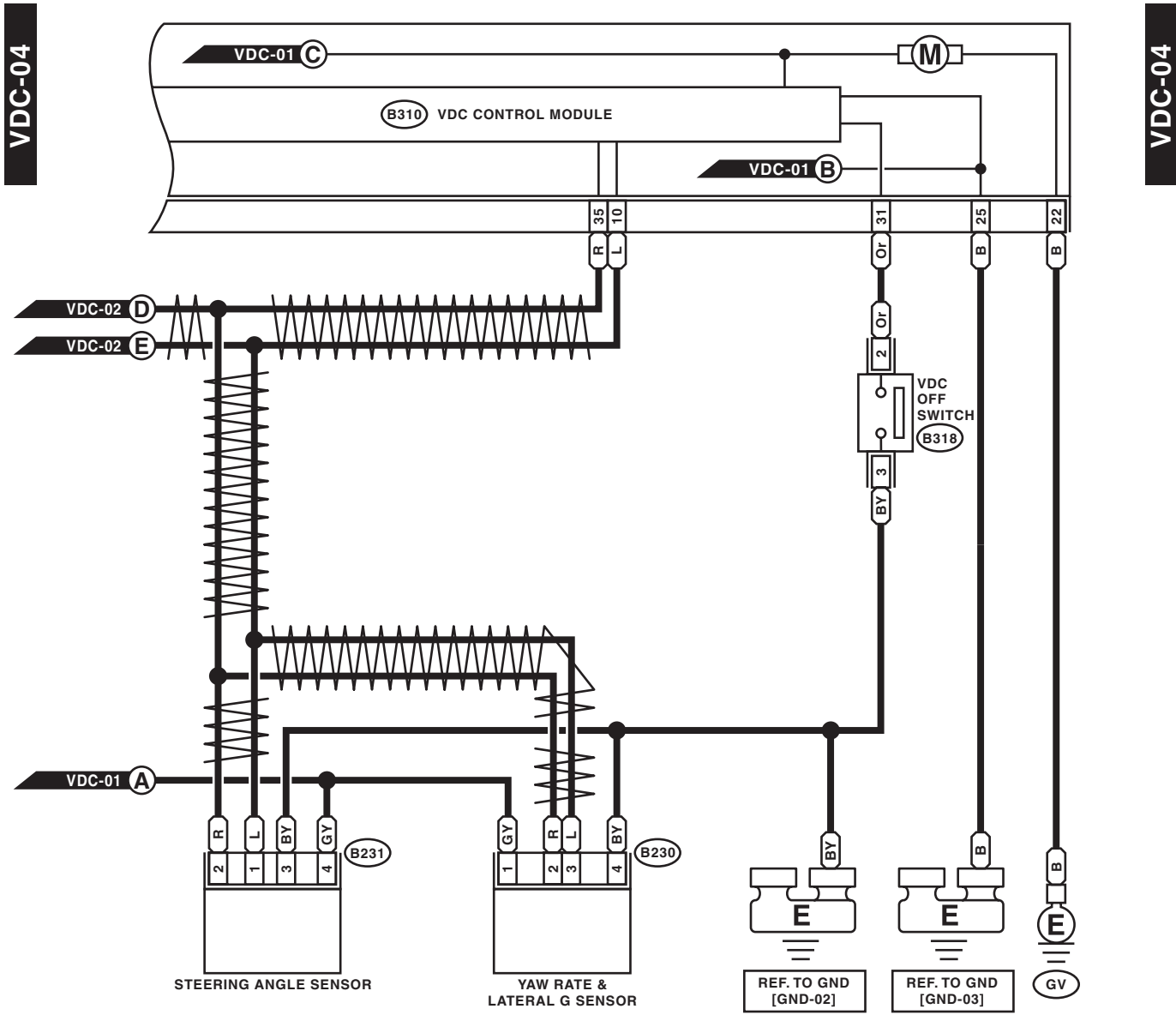

WI-16919

# Tire Pressure Monitoring System

WIRING SYSTEM

Brought to you by Eris Studios  
NOT FOR SALE

## 14. Tire Pressure Monitoring System

### A: WIRING DIAGRAM

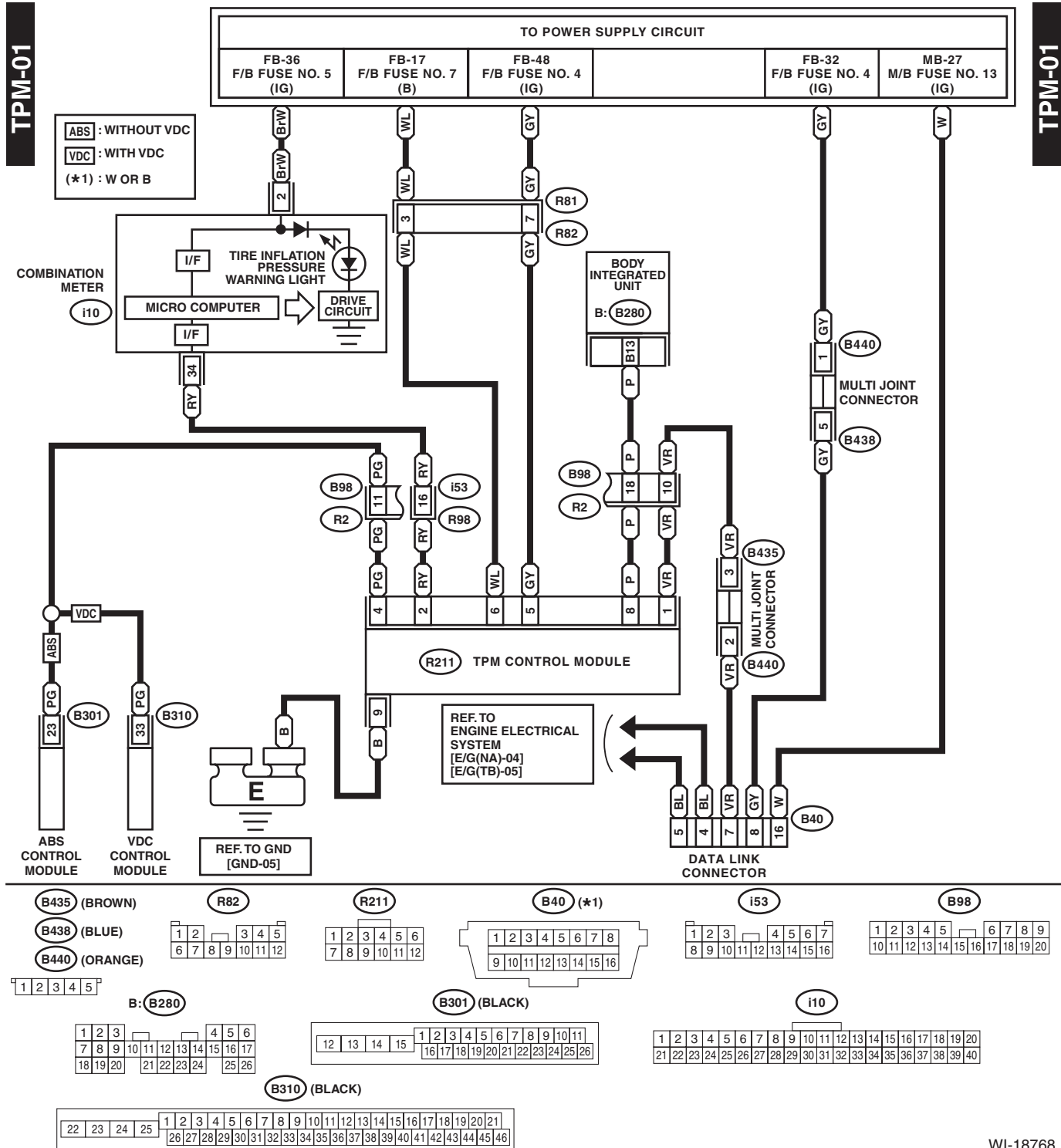

Brought to you by Chris Studios  
NOT FOR SALE

## 15. Air Conditioning System

### A: WIRING DIAGRAM

#### 1. MANUAL A/C MODEL

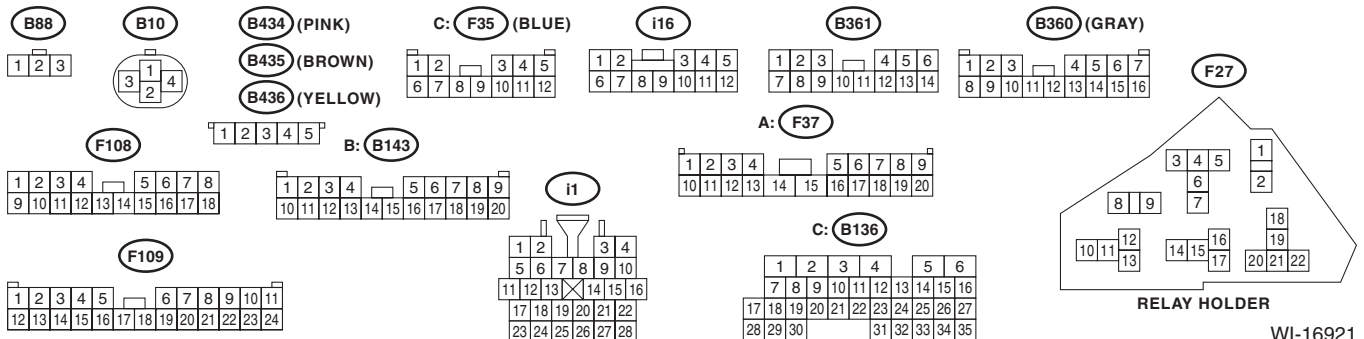
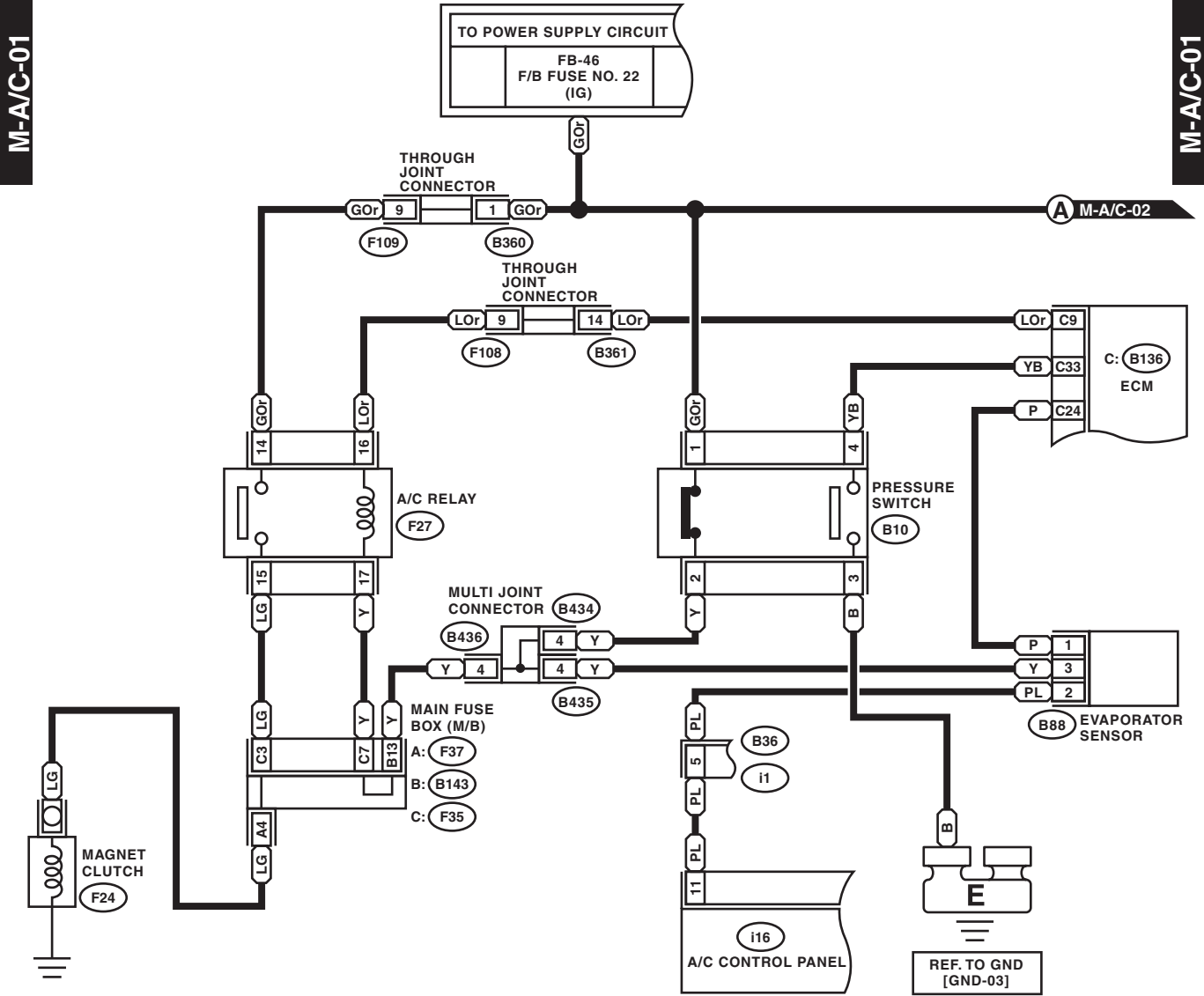

WI-16921

# Air Conditioning System

Brought to you by Eris Studios  
NOT FOR RESALE

## WIRING SYSTEM

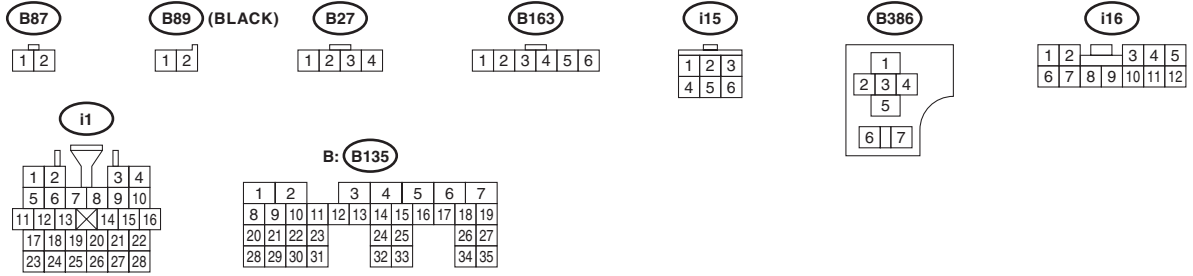
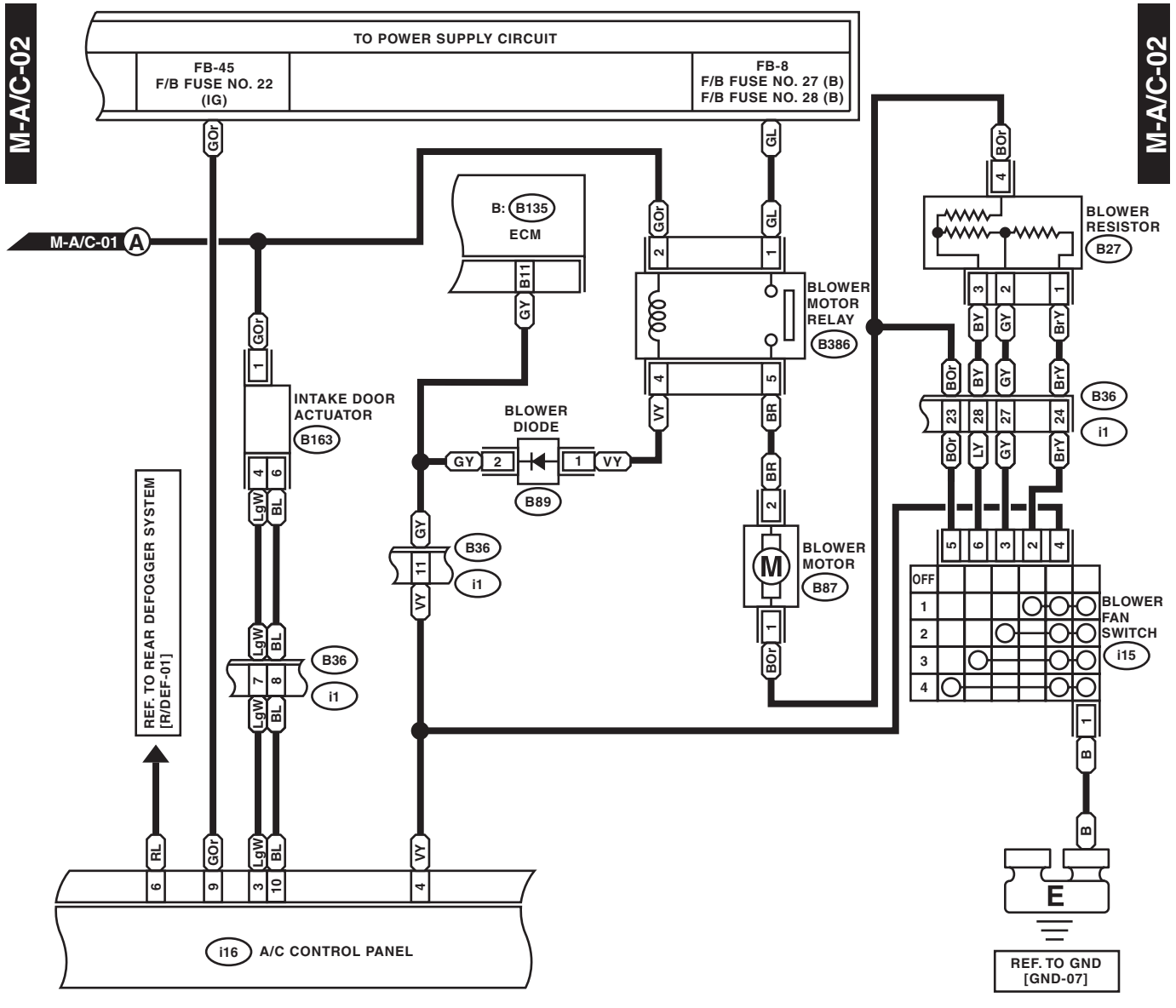

WI-16922

# Air Conditioning System

## WIRING SYSTEM

Brought to you by *Chris Studios*  
NOT FOR SALE

M-A/C-03

M-A/C-03

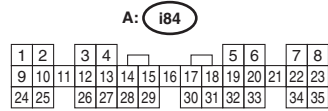
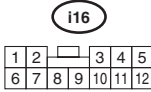
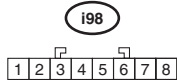
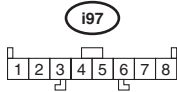
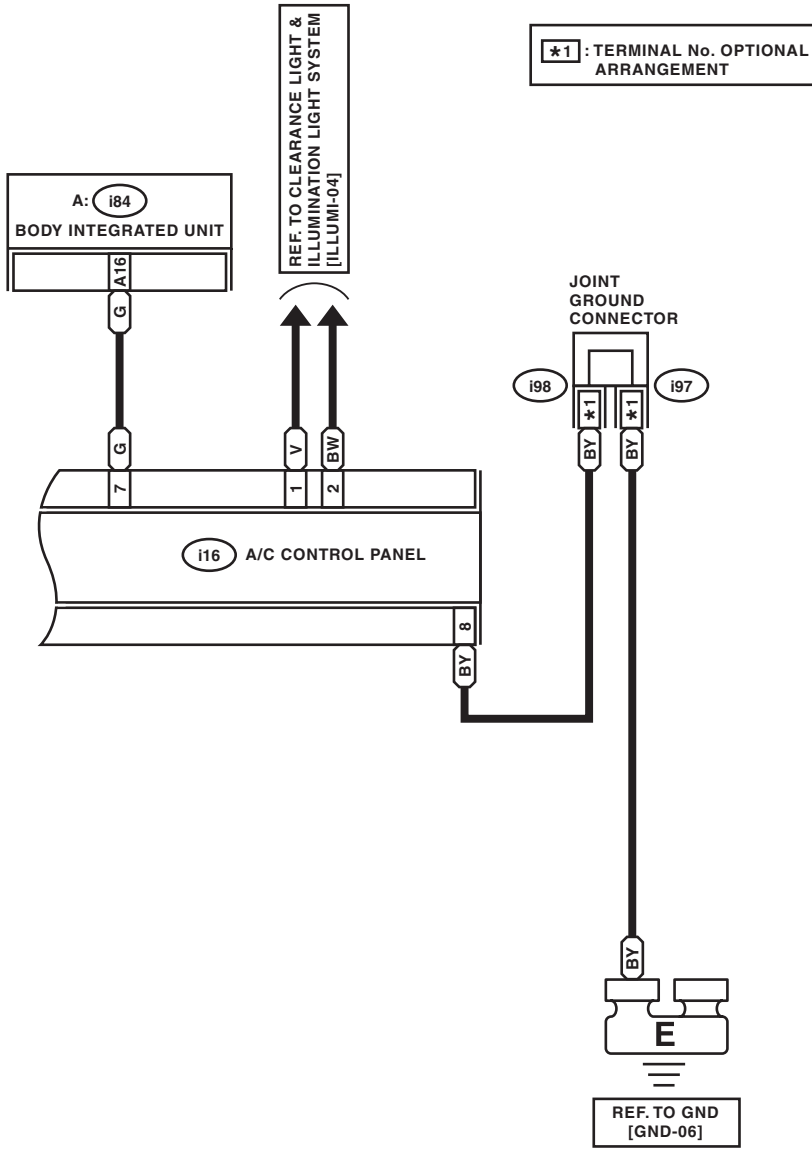

WI-16923

# Air Conditioning System

Brought to you by Eris Studios  
NOT FOR RESALE

## WIRING SYSTEM

### 2. AUTO A/C MODEL

A-A/C-01

A-A/C-01

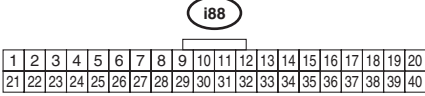
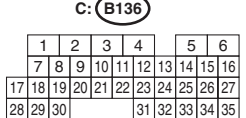
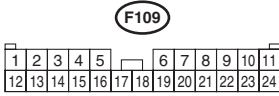
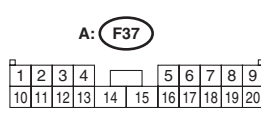
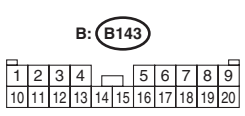
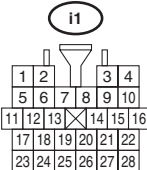
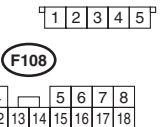
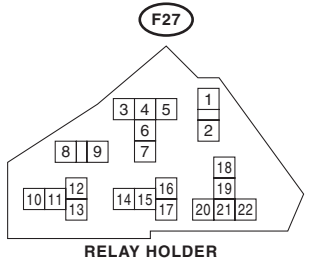
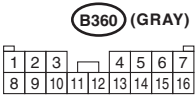
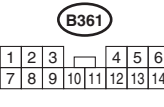
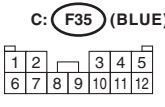
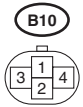
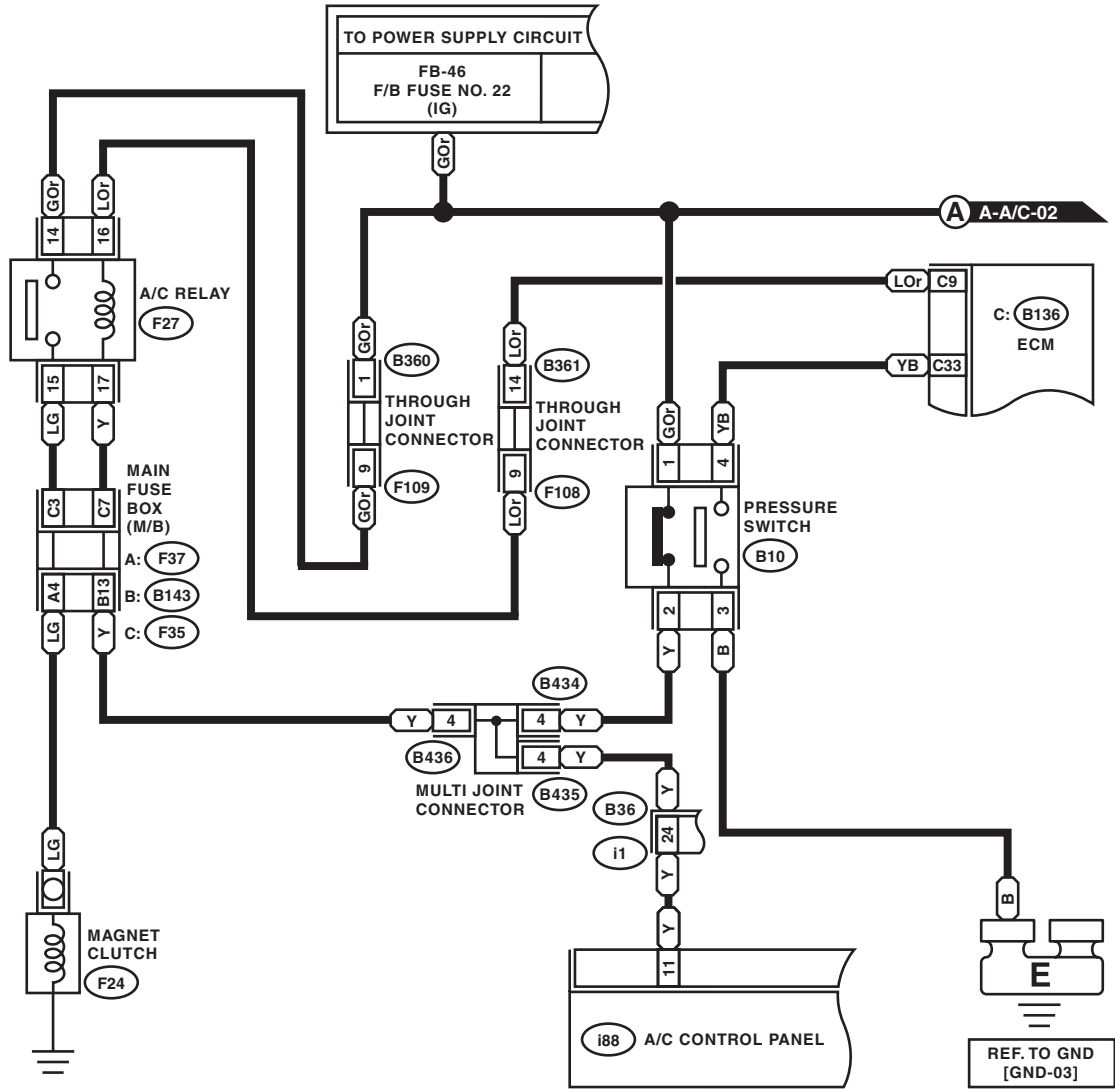

WI-16924



# Air Conditioning System

## WIRING SYSTEM

Brought to you by  
NOVUS  
SALES Studios

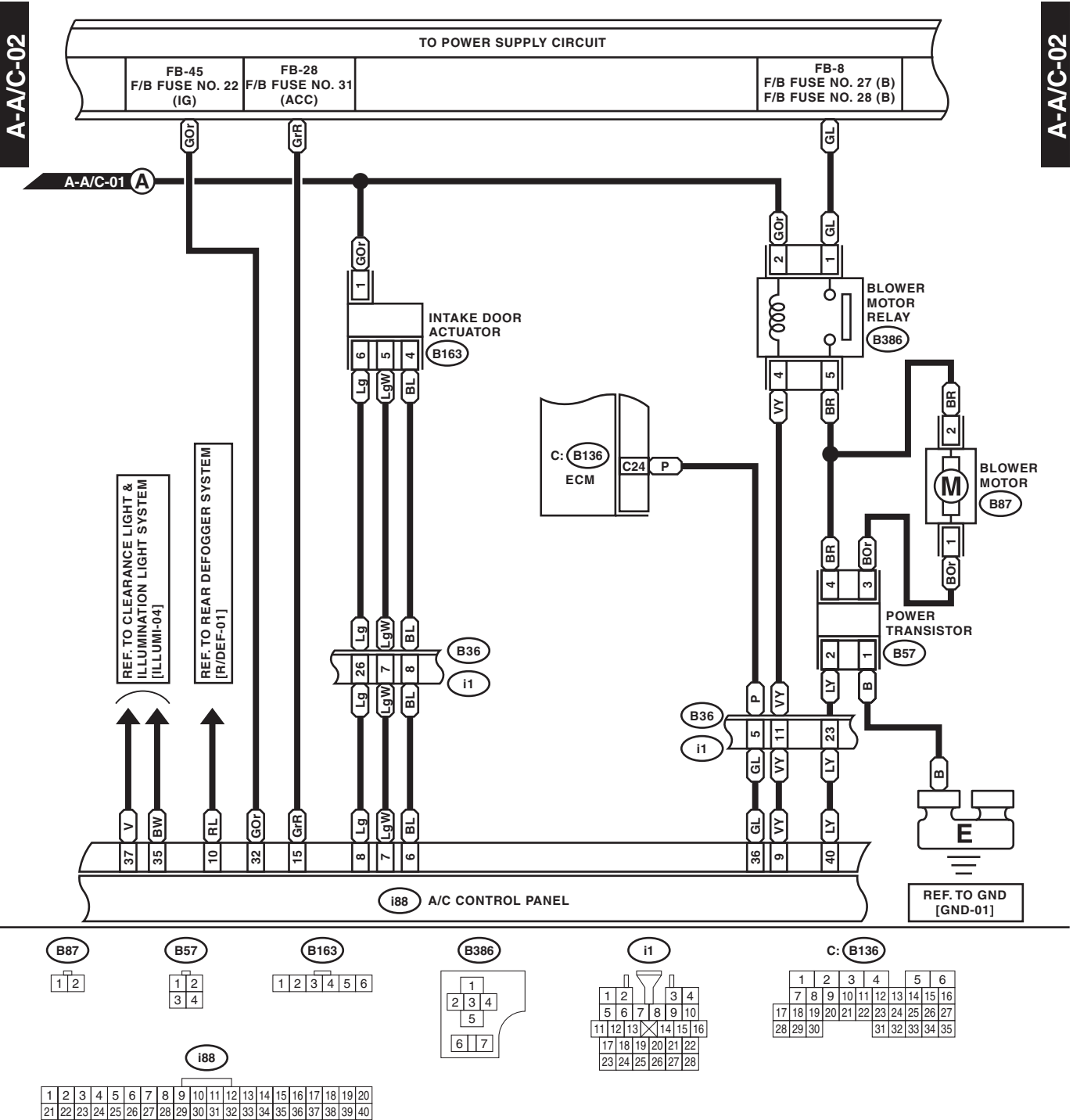

WI-16925

# Air Conditioning System

Brought to you by Eris Studios  
NOT FOR RESALE

## WIRING SYSTEM

A-A/C-03

A-A/C-03

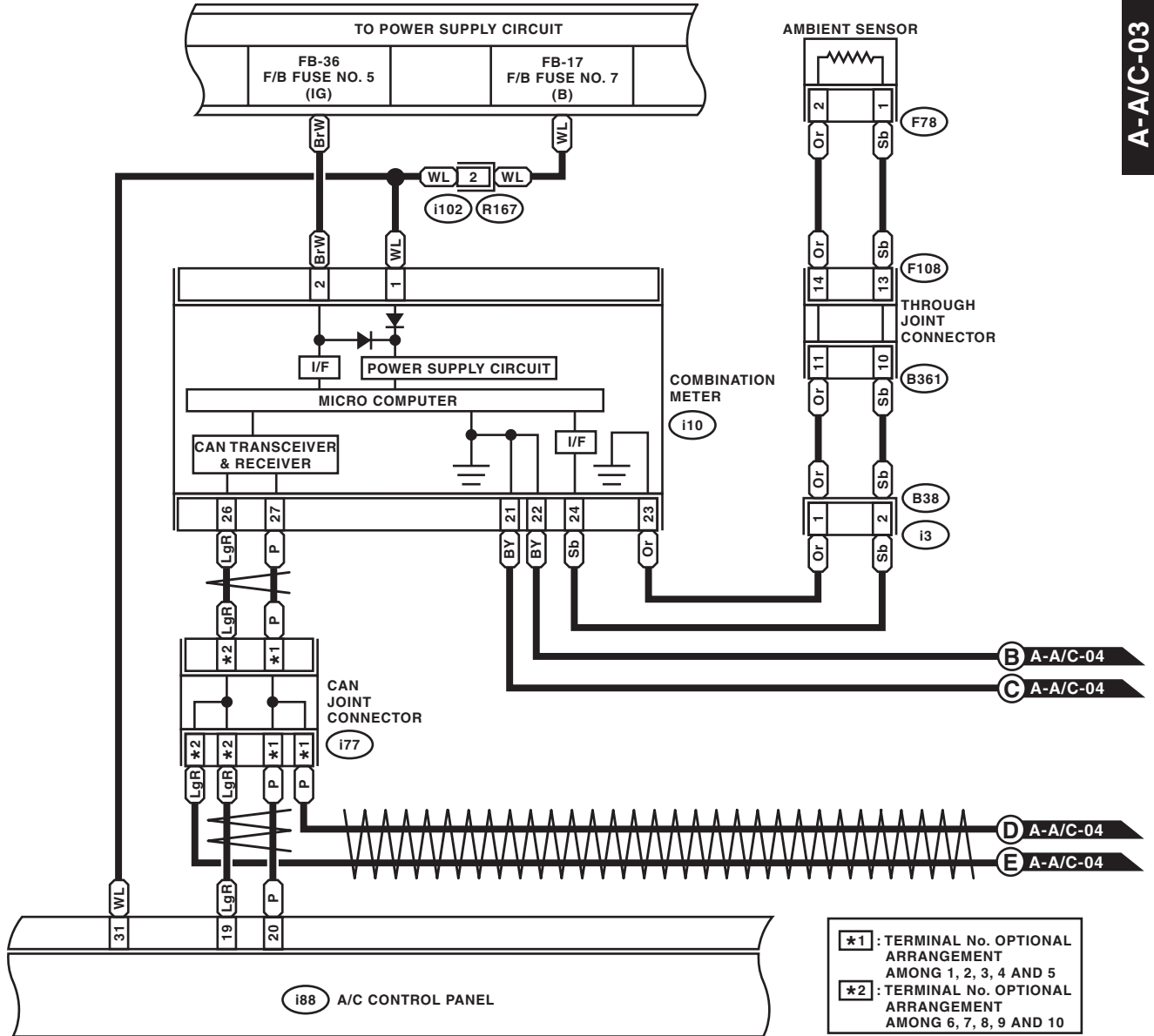

\*1 : TERMINAL No. OPTIONAL ARRANGEMENT AMONG 1, 2, 3, 4 AND 5  
 \*2 : TERMINAL No. OPTIONAL ARRANGEMENT AMONG 6, 7, 8, 9 AND 10

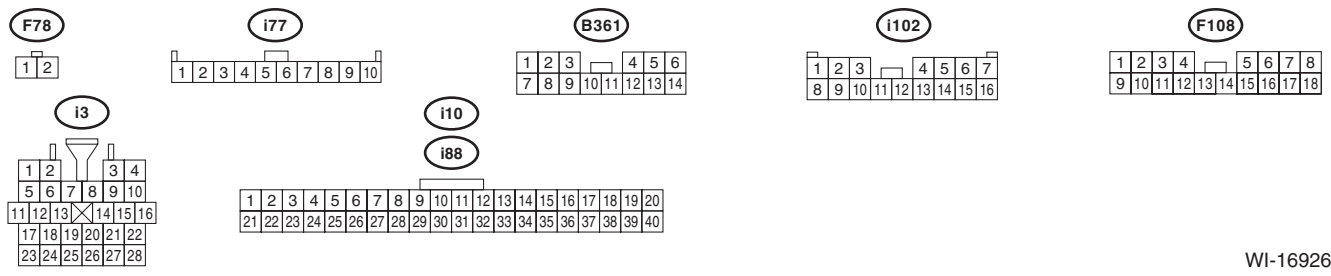

WI-16926

# Air Conditioning System

## WIRING SYSTEM

Brought to you by *Meris Studios*  
NOT FOR SALE

A-A/C-04

A-A/C-04

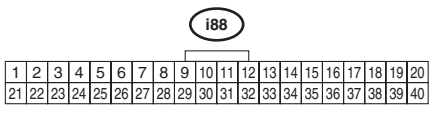
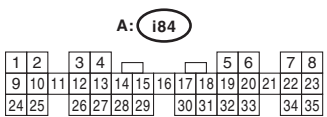
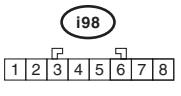
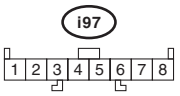
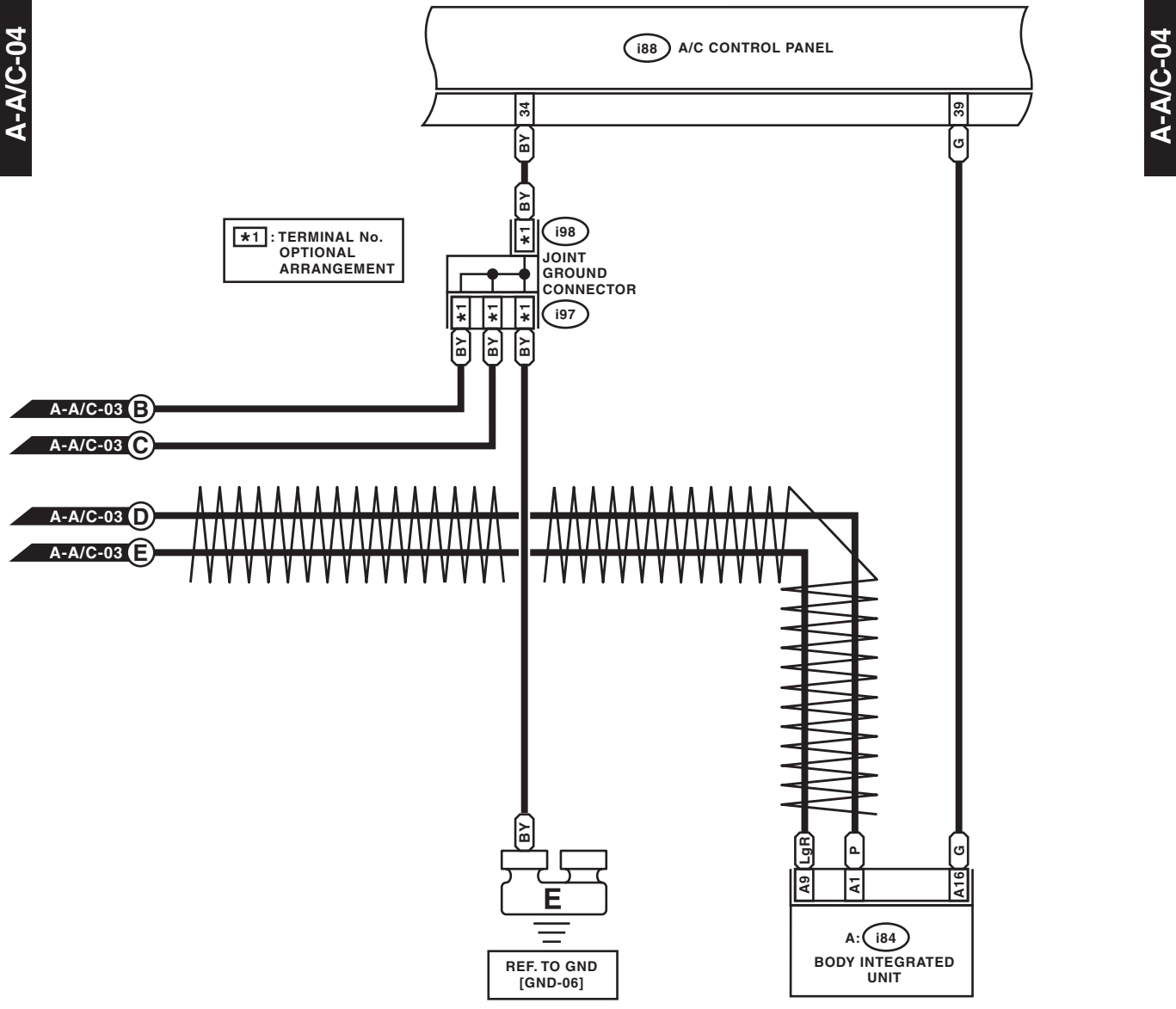

WI-16927

# Air Conditioning System

## WIRING SYSTEM

Brought to you by Eris Studios  
NOT FOR RESALE

A-A/C-05

A-A/C-05

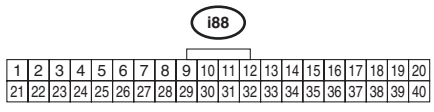
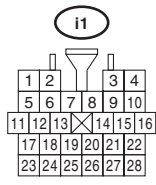
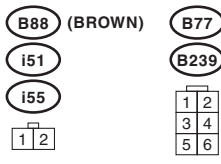
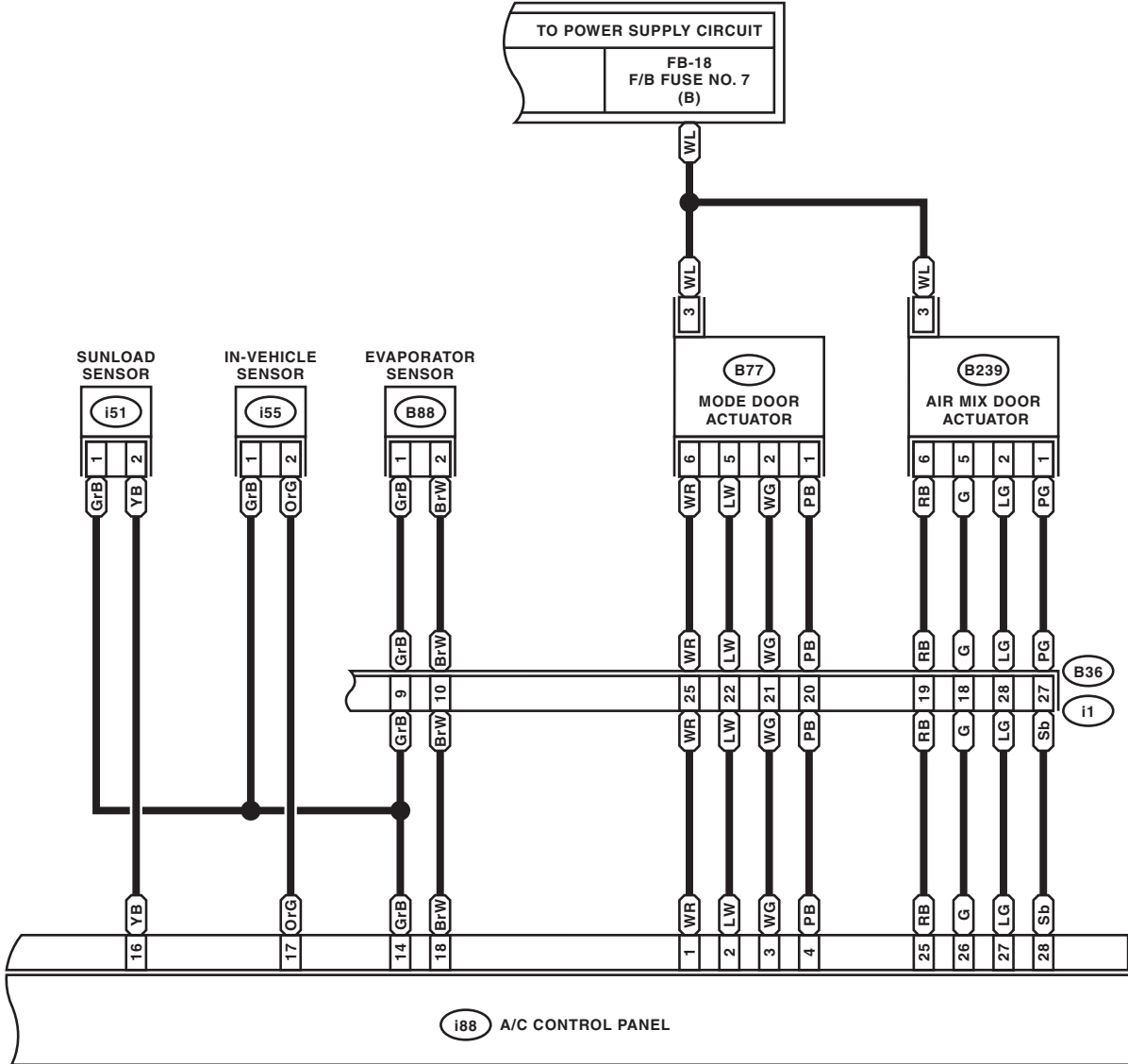

WI-17954

Brought to you by Pro's Studios  
NO COPYRIGHT SALE

## 16. Airbag System

### A: WIRING DIAGRAM

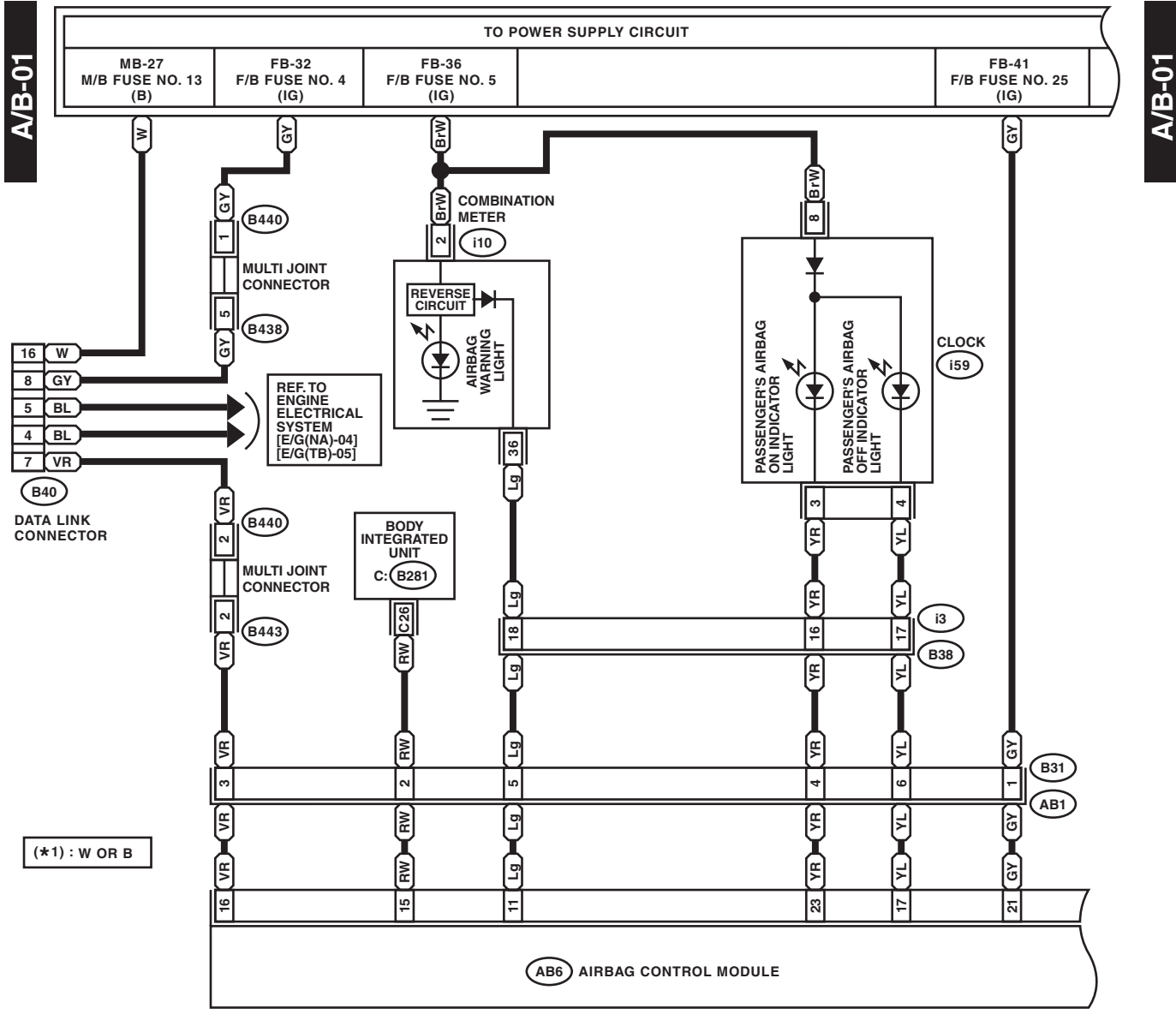

(\*) : W OR B

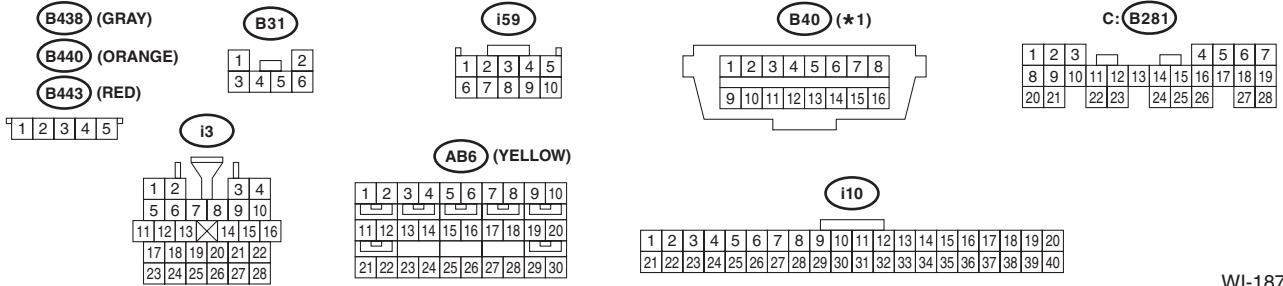

WI-18769

# Airbag System

## WIRING SYSTEM

Brought to you by Eris Studios  
NOT FOR RESALE

A/B-02

A/B-02

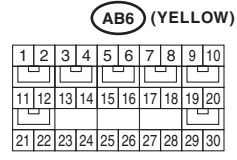
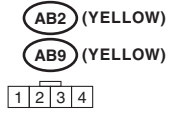
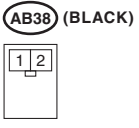
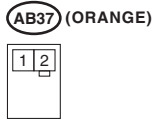
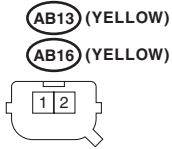
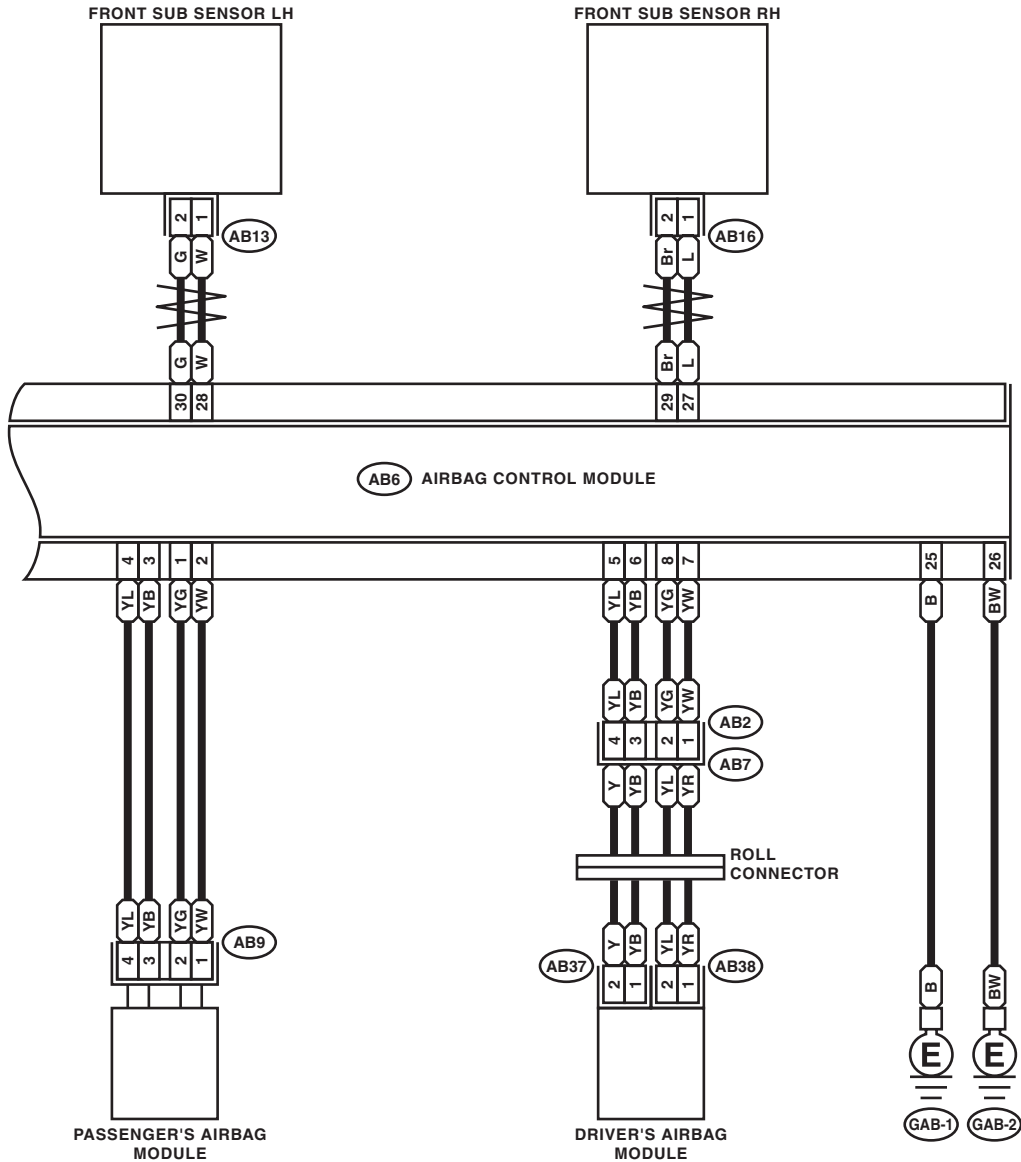

WI-16929

# Airbag System

WIRING SYSTEM

Brought to you by *Chris Studios*  
 NOT FOR SALE

A/B-03

A/B-03

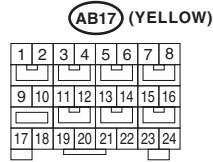
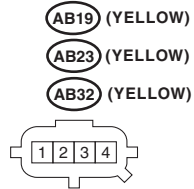
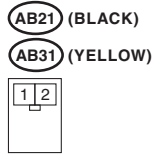
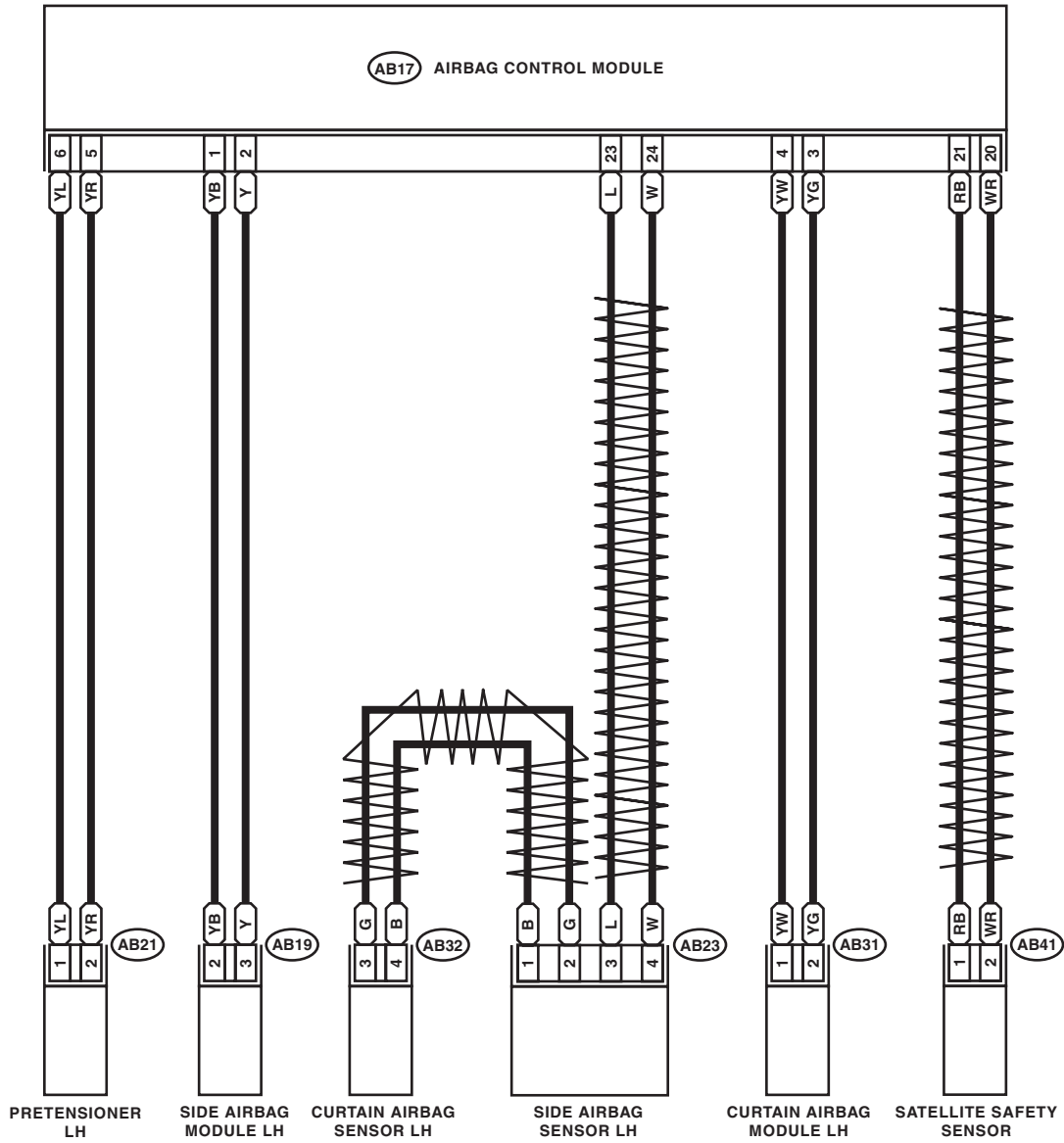

WI-16930

# Airbag System

## WIRING SYSTEM

Brought to you by Eris Studios  
NOT FOR RESALE

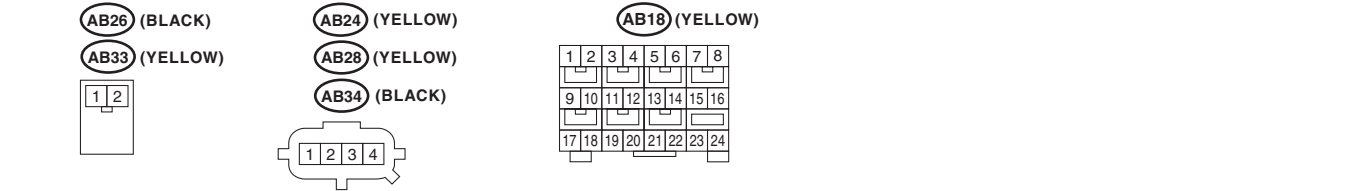
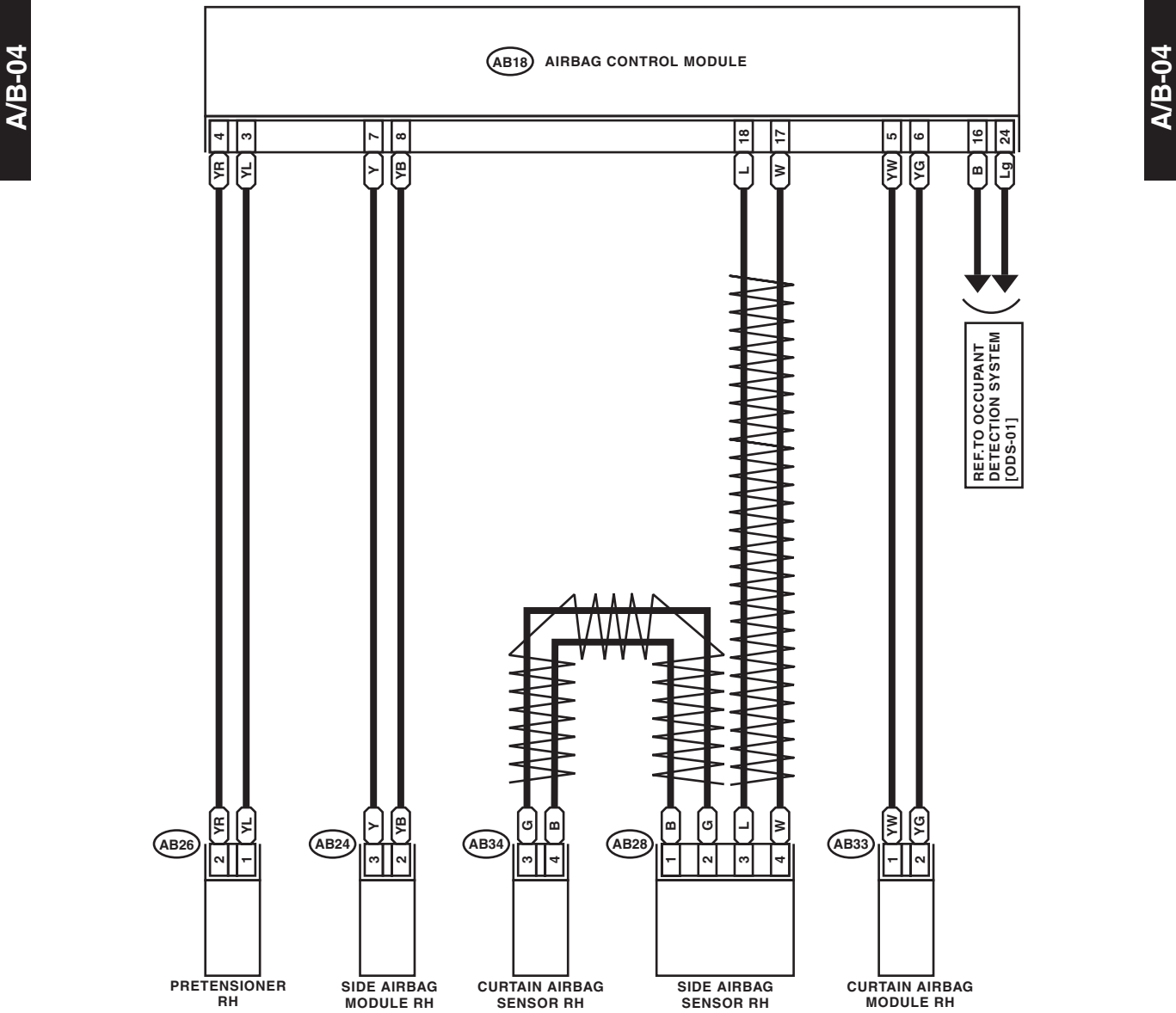

WI-16931



## 17. Seat Belt Warning System

### A: WIRING DIAGRAM

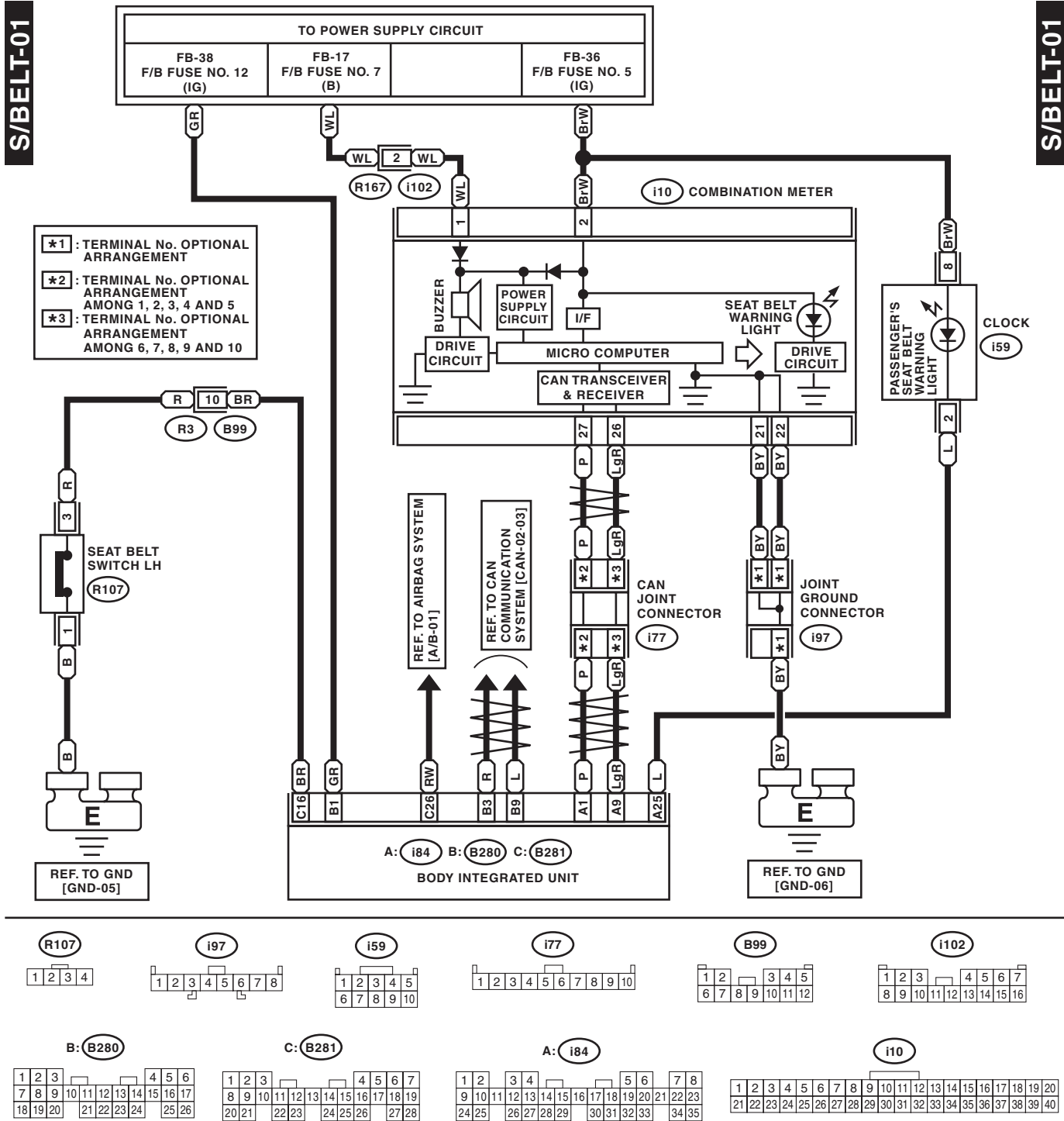

# Occupant Detection

Brought to you by Eris Studios  
NOT FOR SALE

WIRING SYSTEM

## 18. Occupant Detection

### A: WIRING DIAGRAM

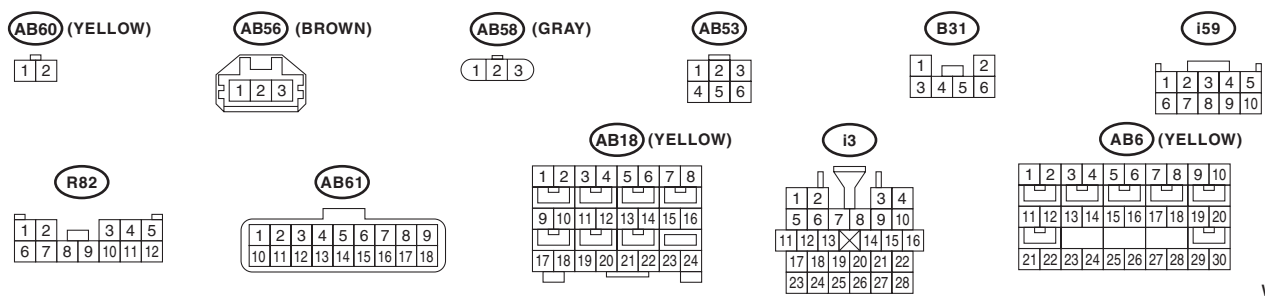
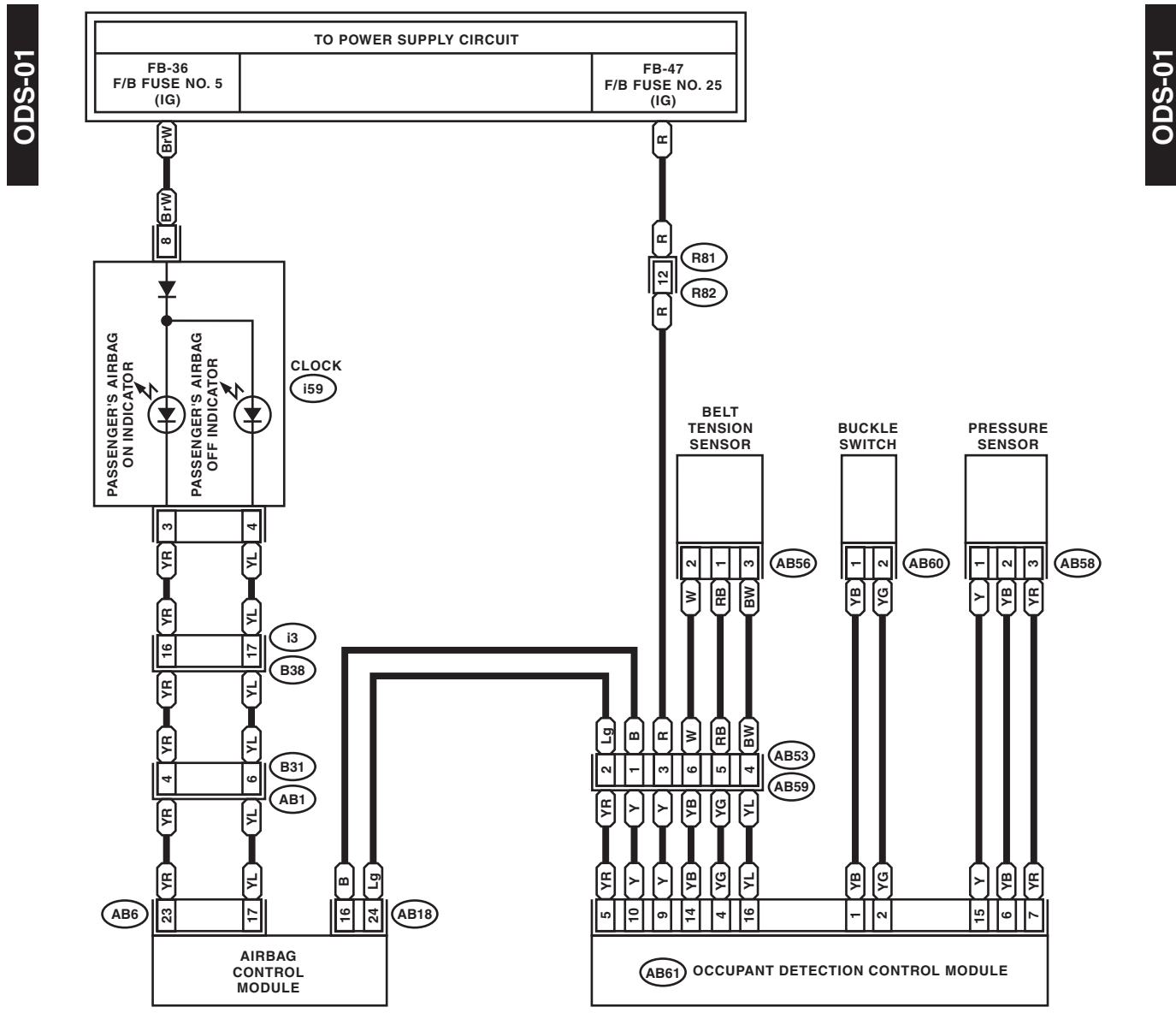

WI-16933

## 19. Seat Heater System

### A: WIRING DIAGRAM

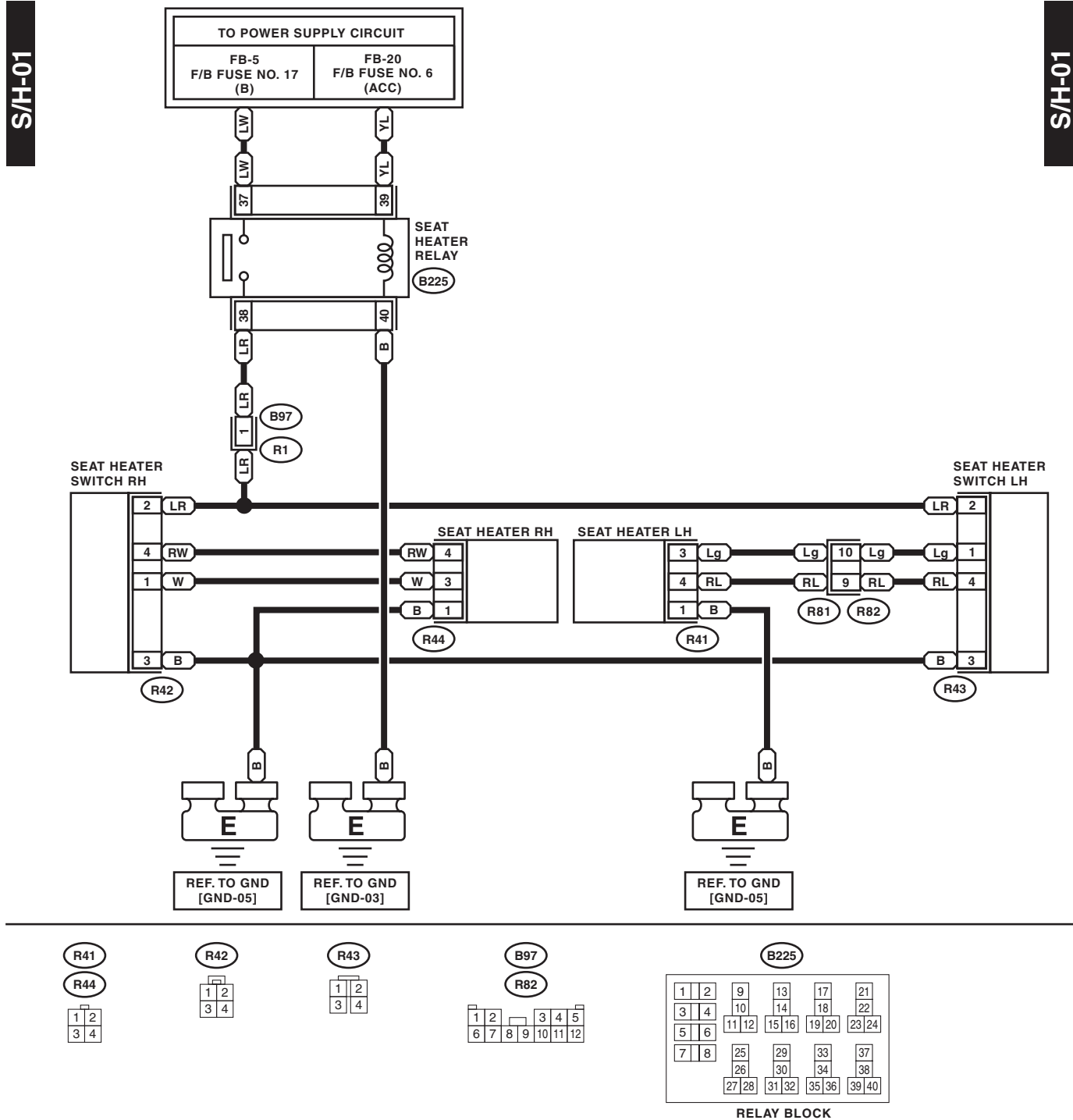

WI-16934

# Headlight System

WIRING SYSTEM

Brought to you by Eris Studios  
NOT FOR RESALE

## 20.Headlight System

### A: WIRING DIAGRAM

H/L-01

H/L-01

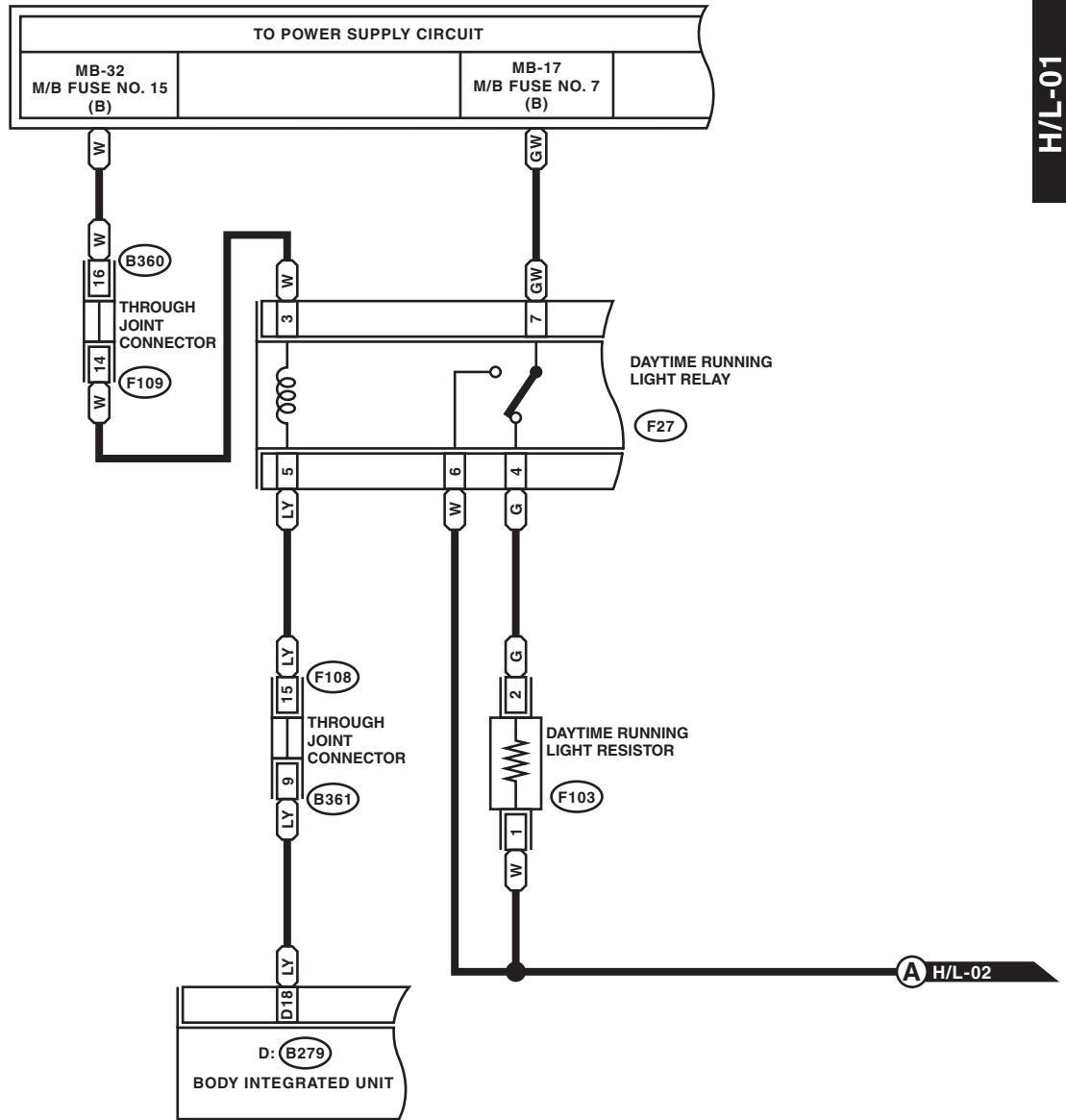

F103



B361

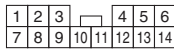

B360 (GRAY)

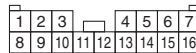

F108

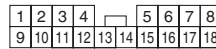

F27

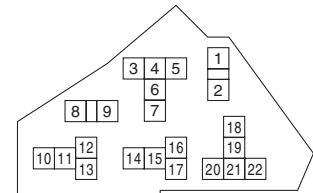

RELAY HOLDER

F109



D: B279



WI-16935

# Headlight System

WIRING SYSTEM

Brought to you by *Chris Studios*  
NOT FOR SALE

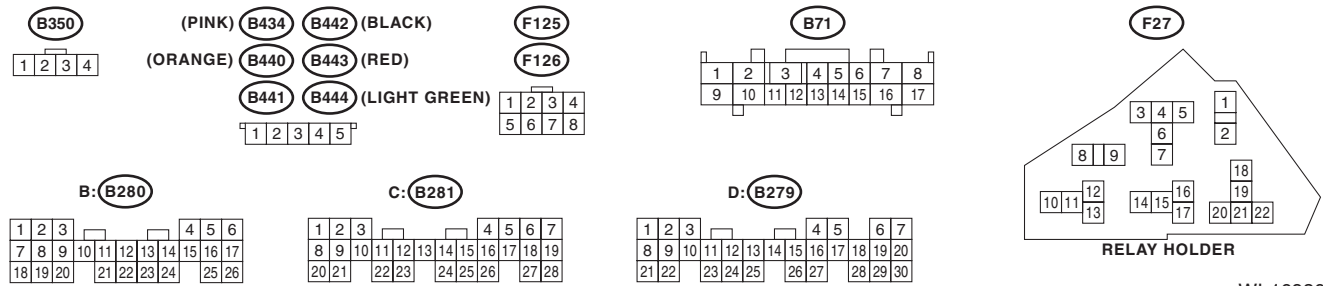
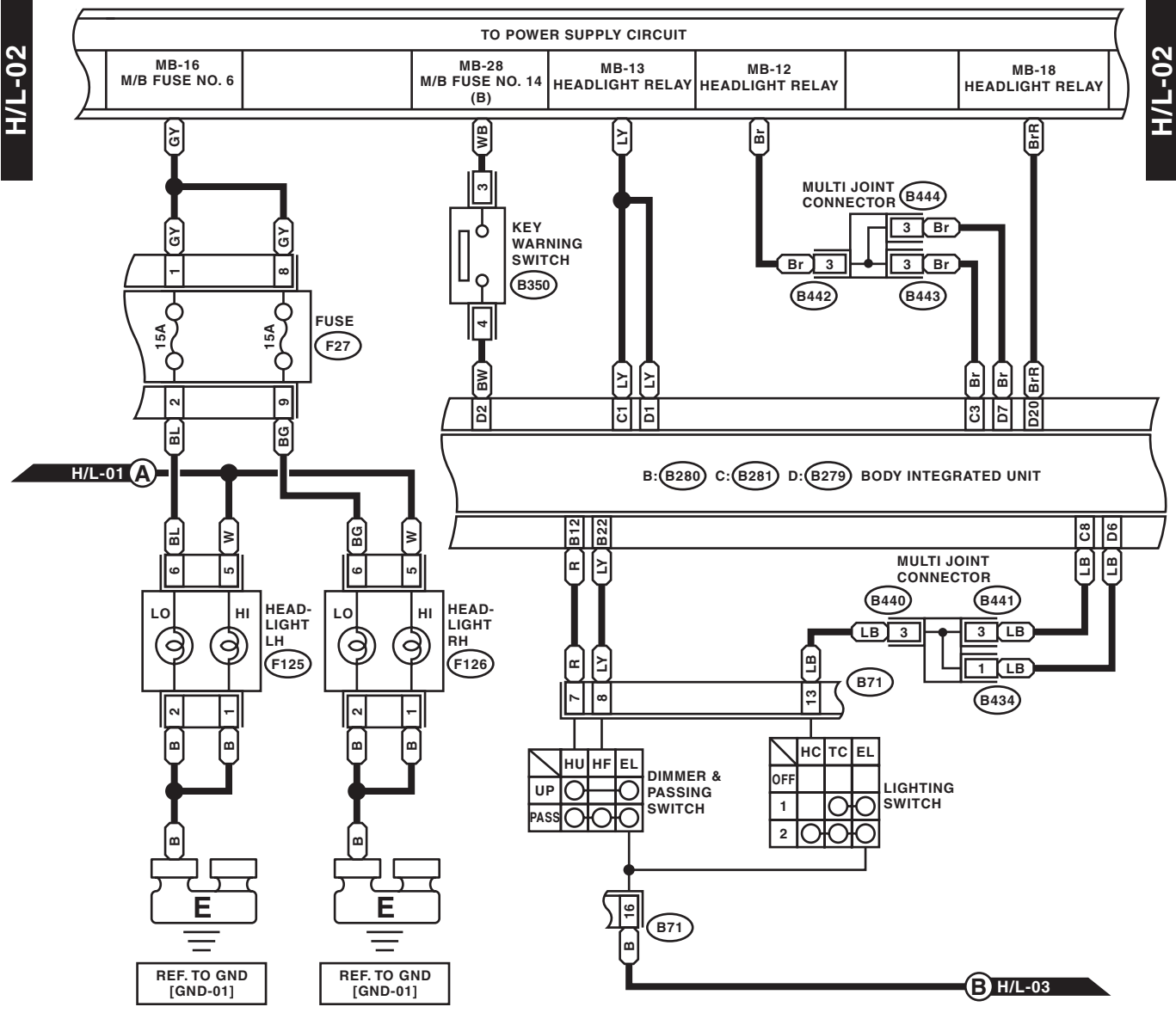

WI-16936

# Headlight System

Brought to you by Eris Studios  
NOT FOR RESALE

## WIRING SYSTEM

H/L-03

H/L-03

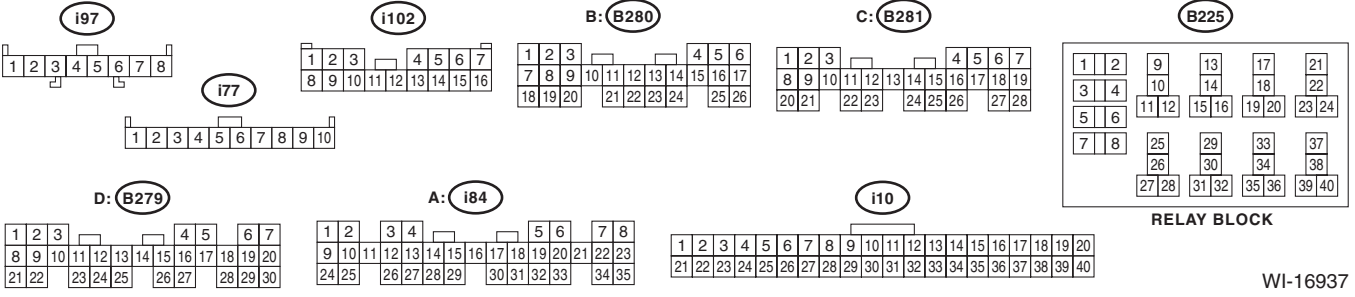
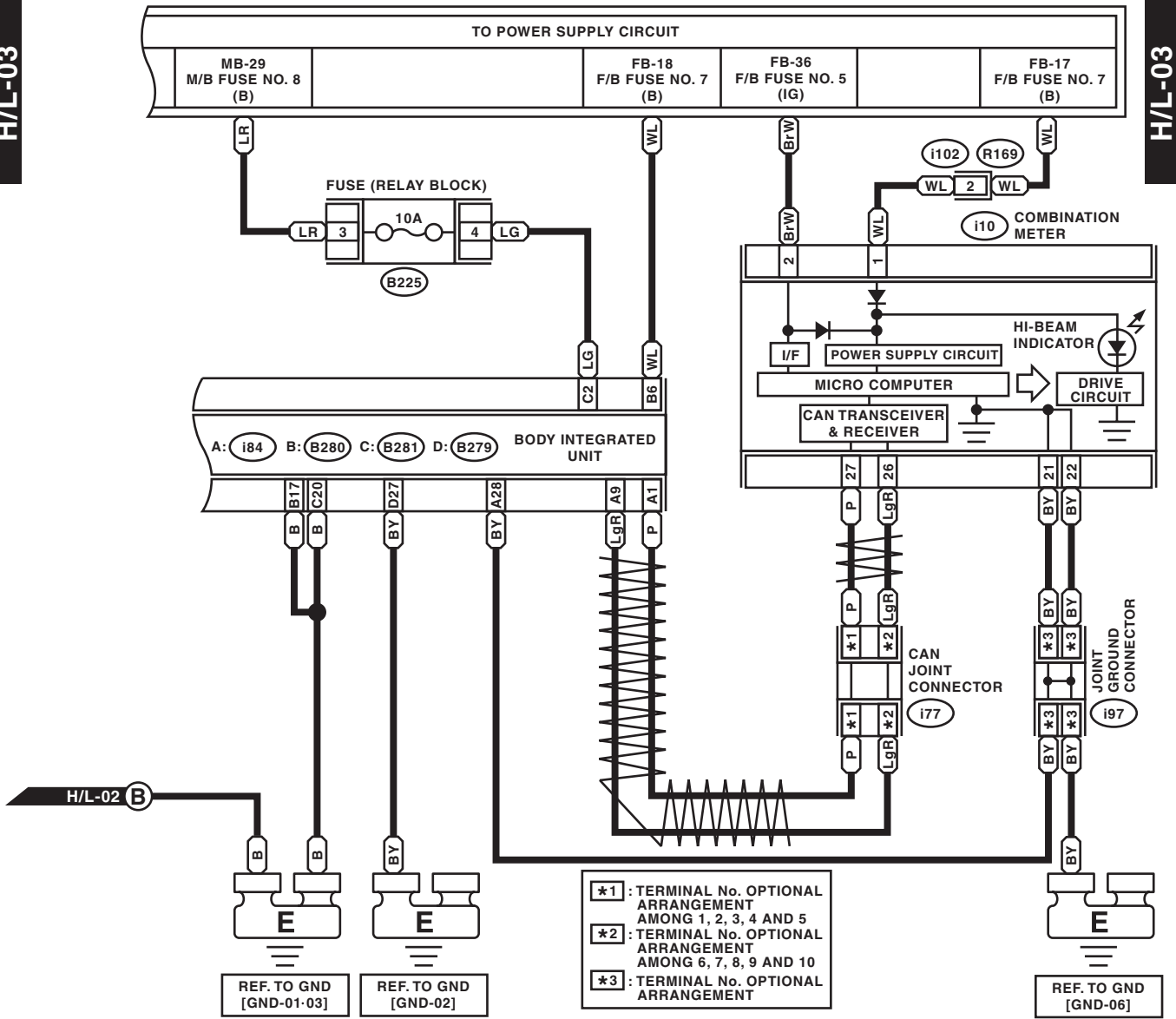

WI-16937

Brought to you by *Chris Studios*  
NOT FOR SALE

## 21. Front Fog Light System

### A: WIRING DIAGRAM

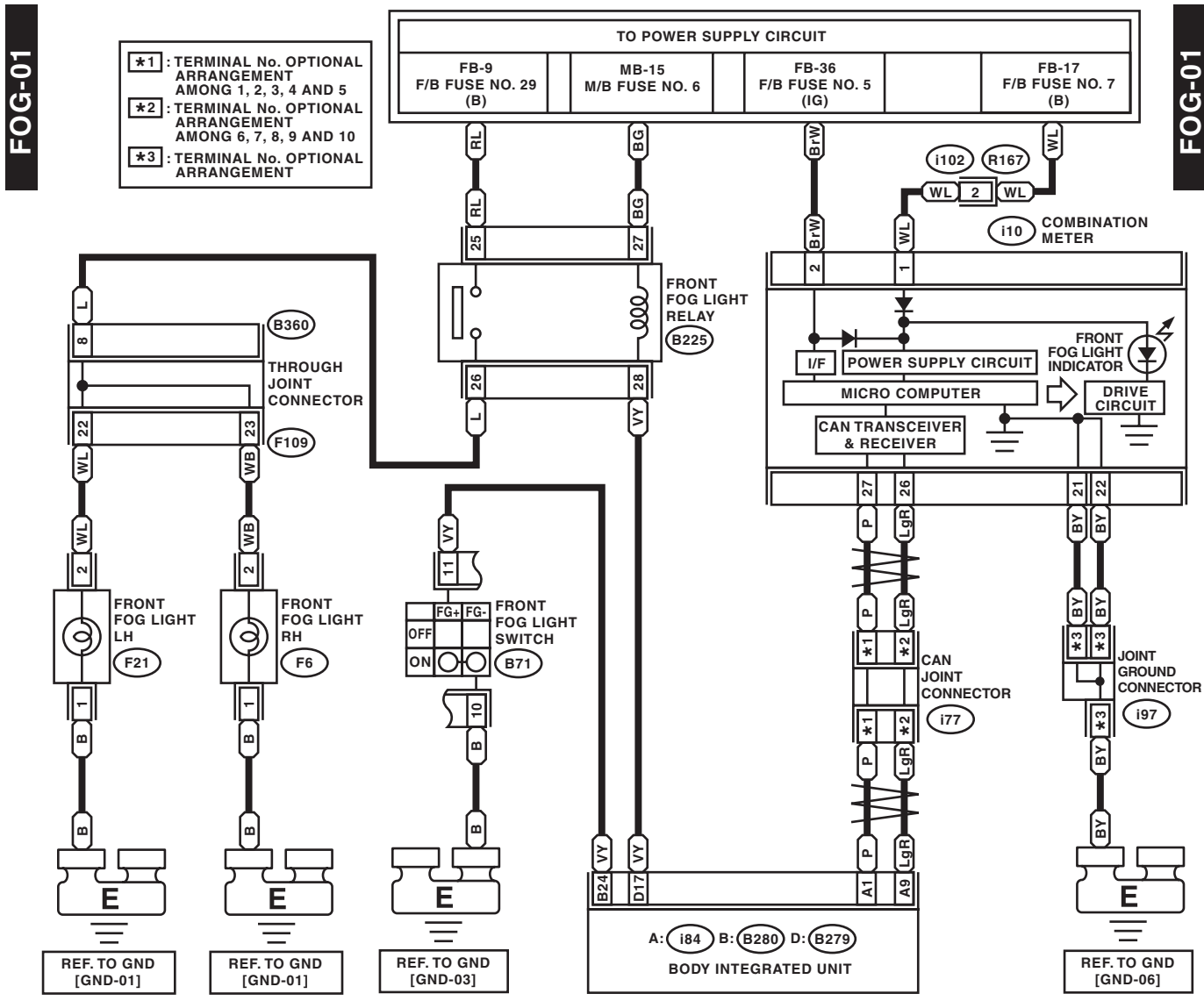

- \*1 : TERMINAL No. OPTIONAL ARRANGEMENT AMONG 1, 2, 3, 4 AND 5
- \*2 : TERMINAL No. OPTIONAL ARRANGEMENT AMONG 6, 7, 8, 9 AND 10
- \*3 : TERMINAL No. OPTIONAL ARRANGEMENT

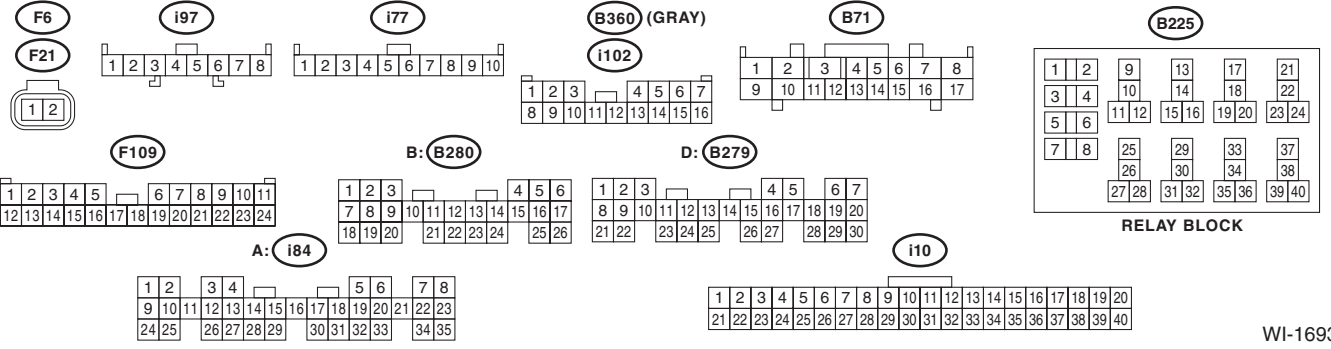

WI-16938

# Back-up Light System

Brought to you by Eris Studios  
NOT FOR RESALE

WIRING SYSTEM

## 22. Back-up Light System

### A: WIRING DIAGRAM

#### 1. TRANSMISSION SERIAL NO. 4078112 OR EARLIER

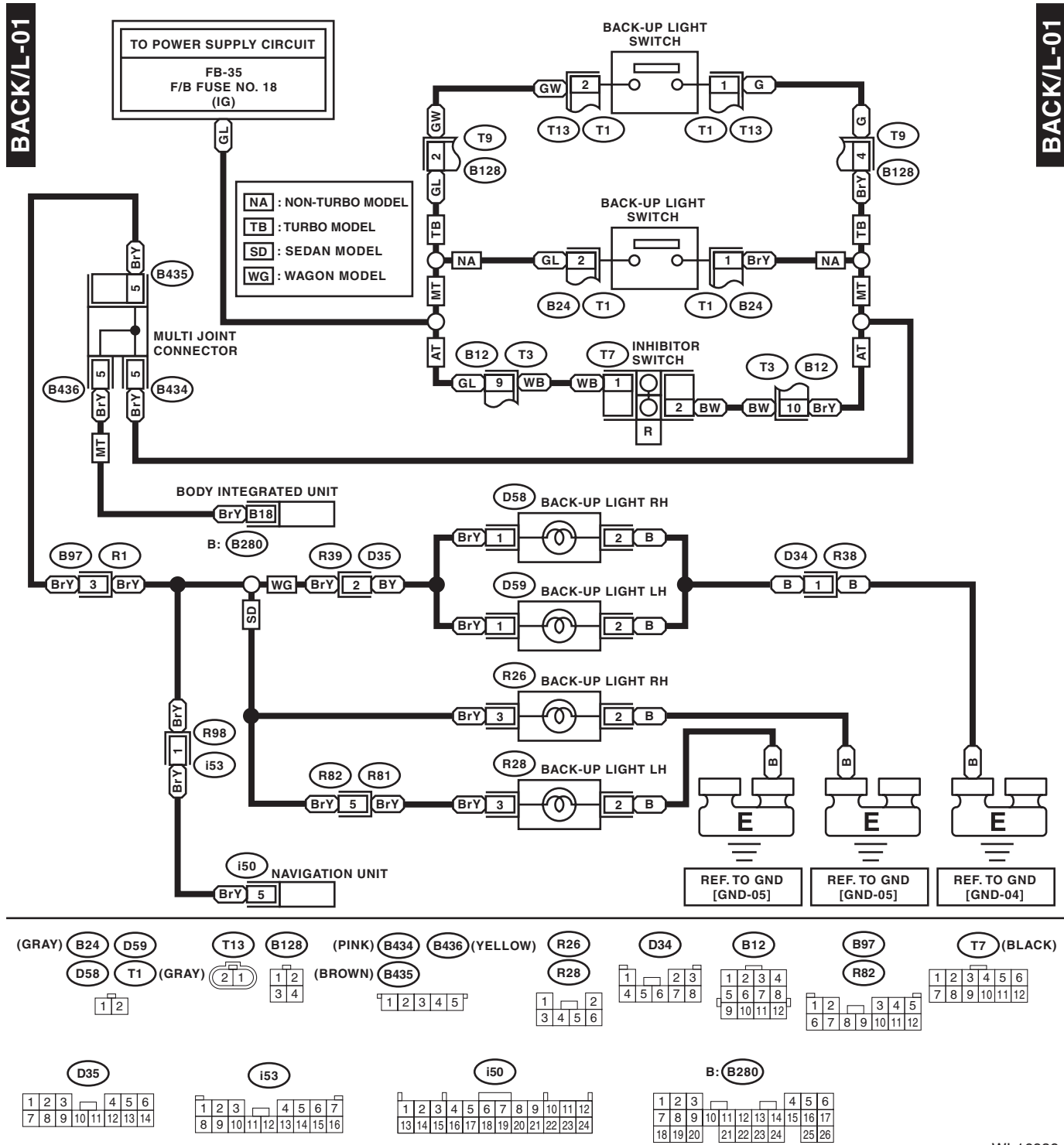

WI-16939



# Back-up Light System

WIRING SYSTEM

Brought to you by *Chris Studios*  
NO RE-SALE

## 2. TRANSMISSION SERIAL NO. 4078113 OR LATER

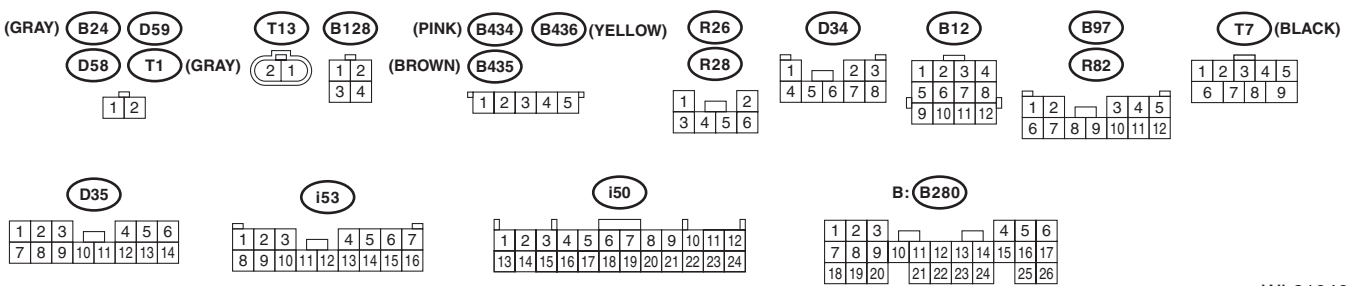
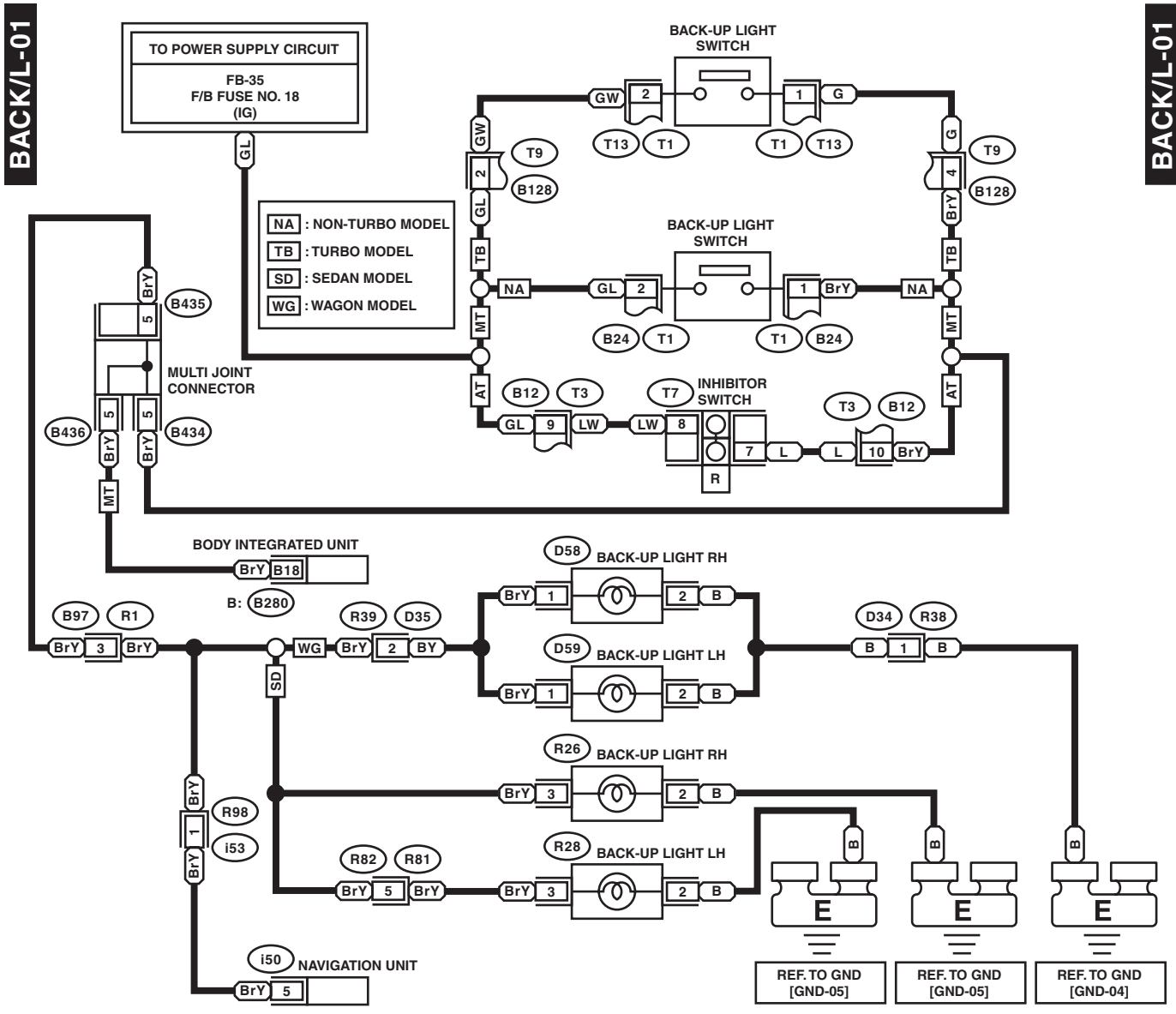

WI-21046

# Stop Light System

Brought to you by Eris Studios  
NOT FOR SALE

## WIRING SYSTEM

### 23. Stop Light System

#### A: WIRING DIAGRAM

##### 1. SEDAN MODEL

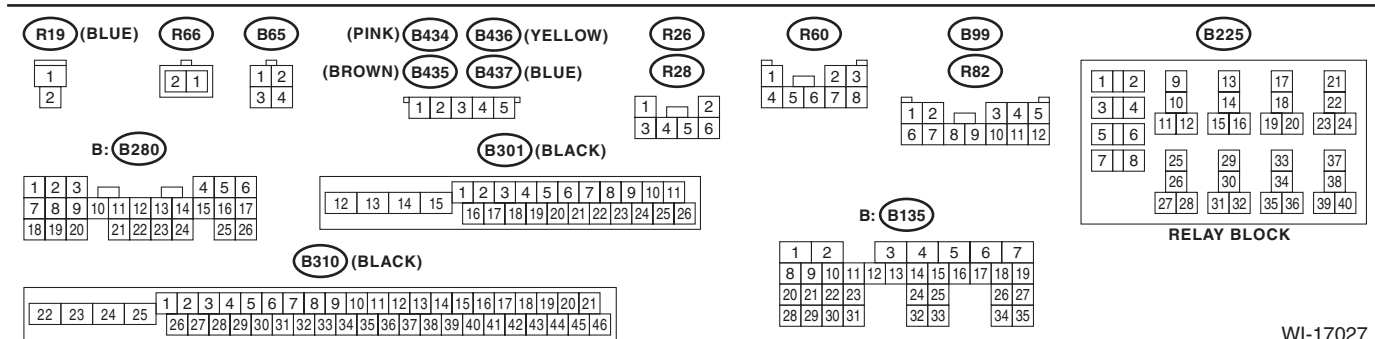
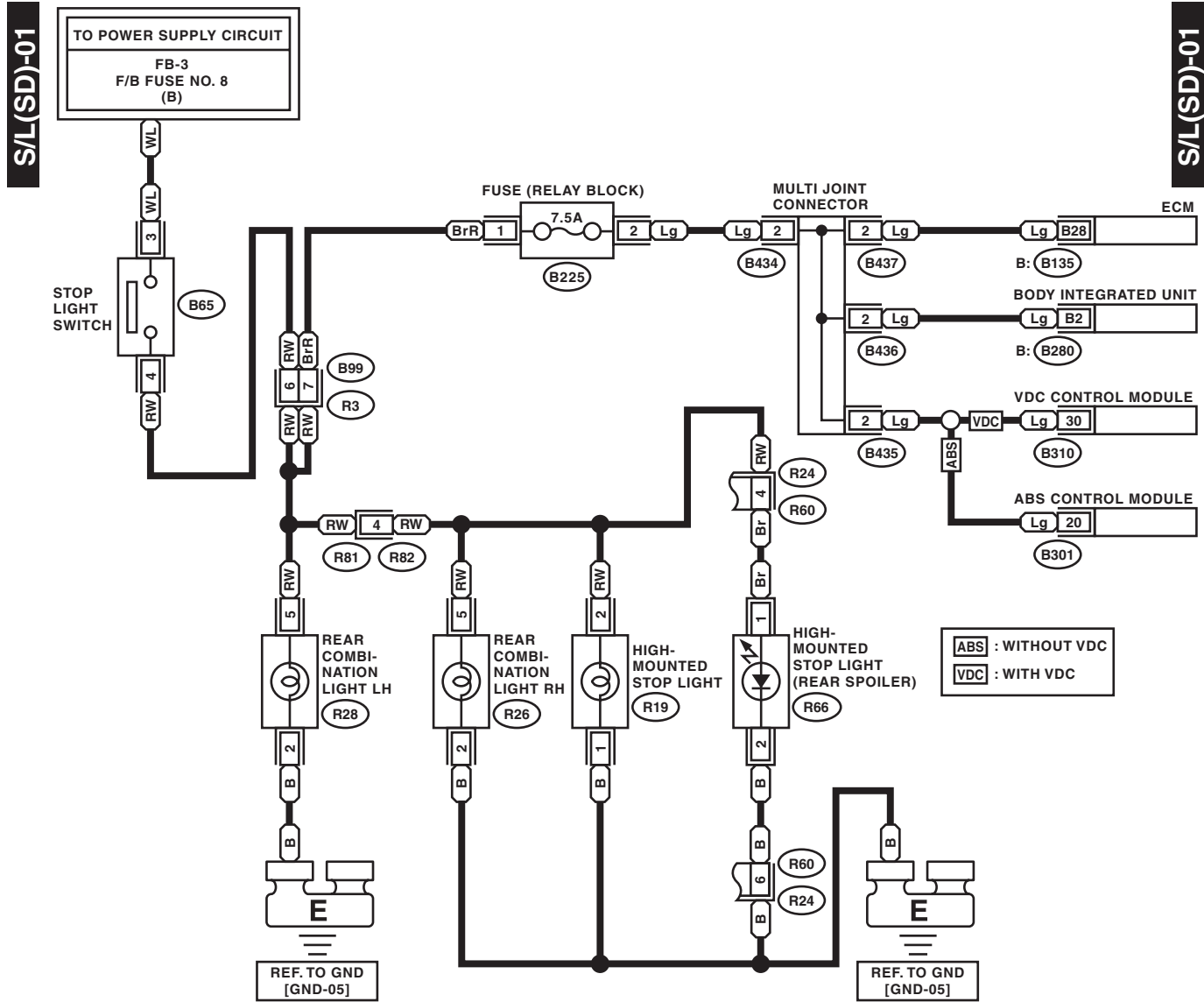

WI-17027

# Stop Light System

WIRING SYSTEM

Brought to you by *Chris Studios*  
NOT FOR SALE

## 2. WAGON MODEL

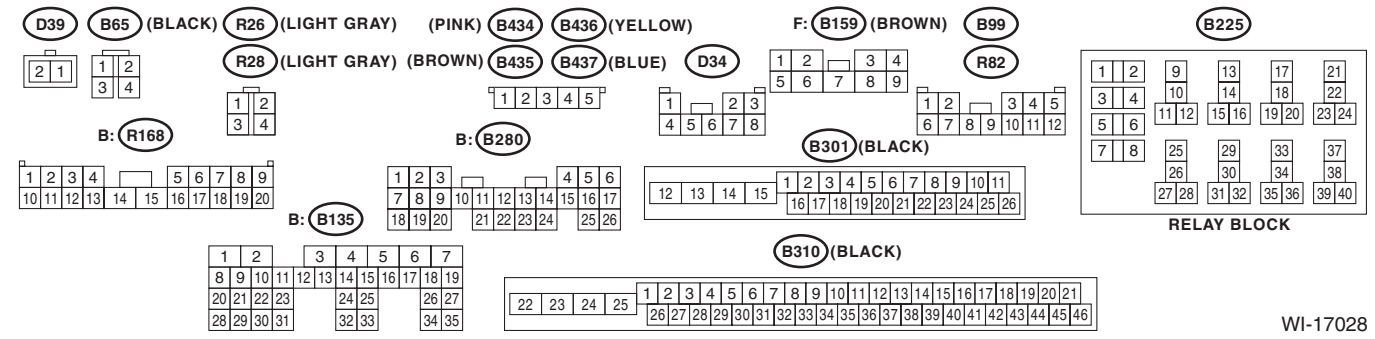
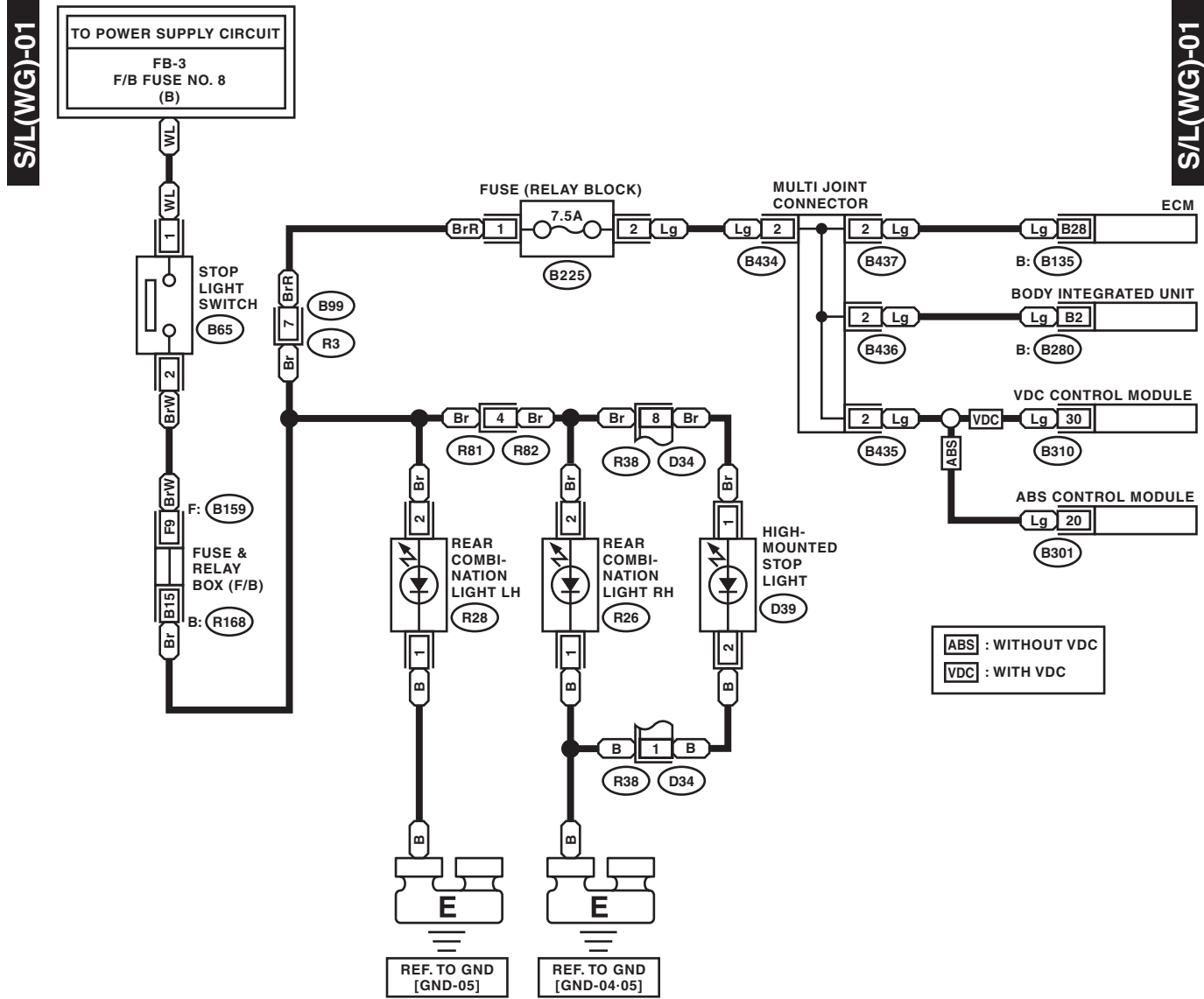

WI-17028

# Clearance Light and Illumination Light System

Brought to you by Eris Studios  
NOT FOR RESALE

WIRING SYSTEM

## 24. Clearance Light and Illumination Light System

### A: WIRING DIAGRAM

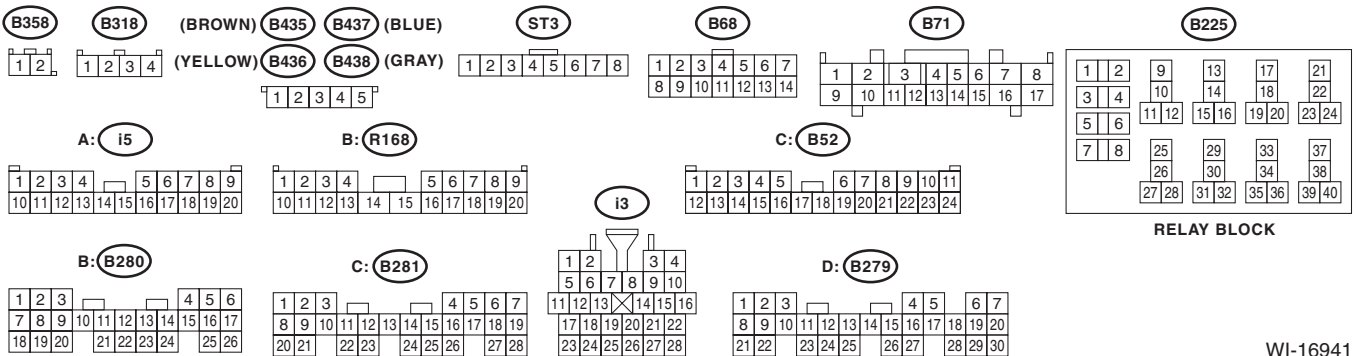
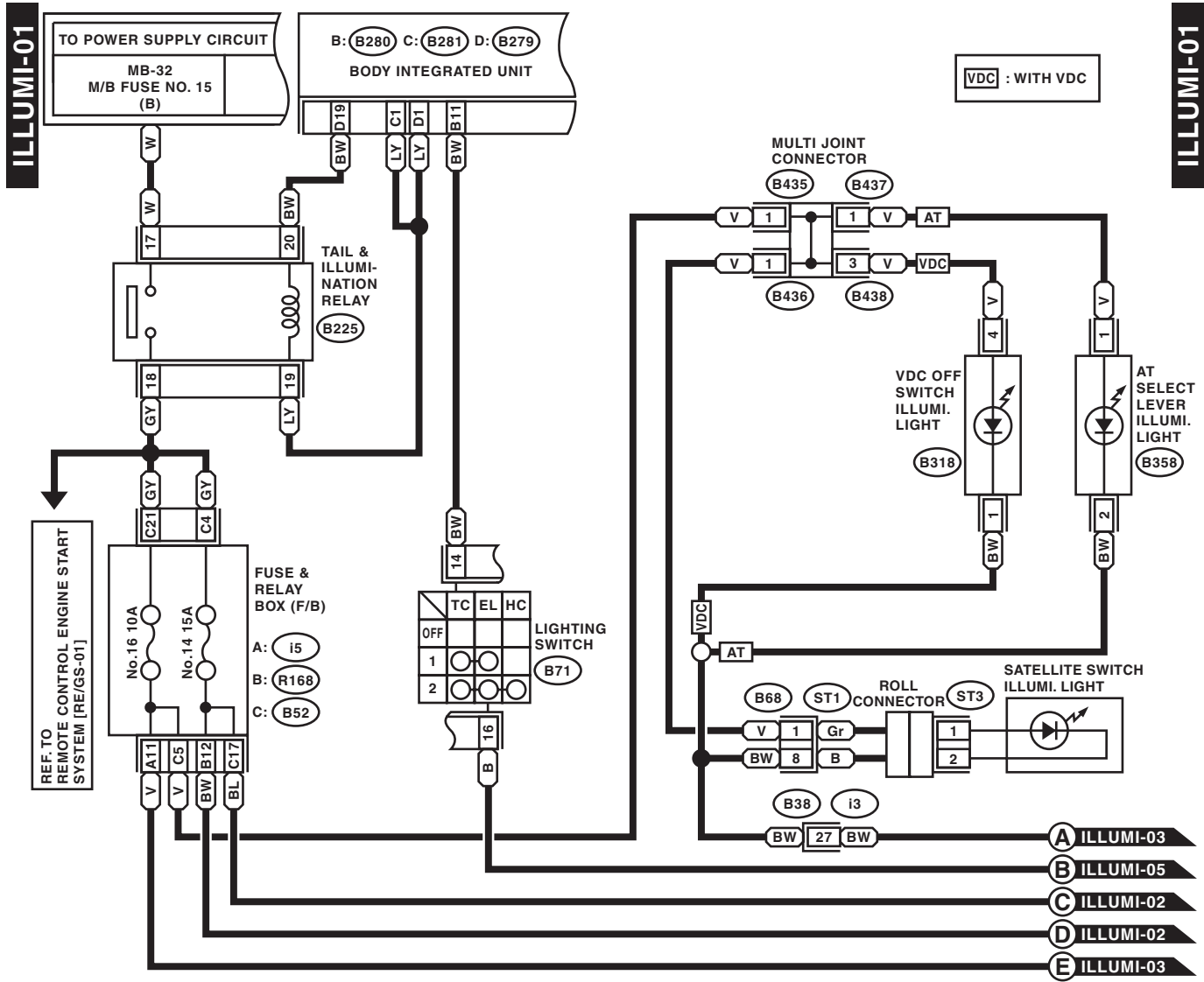

WI-16941

# Clearance Light and Illumination Light System

WIRING SYSTEM

Brought to you by *Chris Studios*  
 NOT FOR SALE

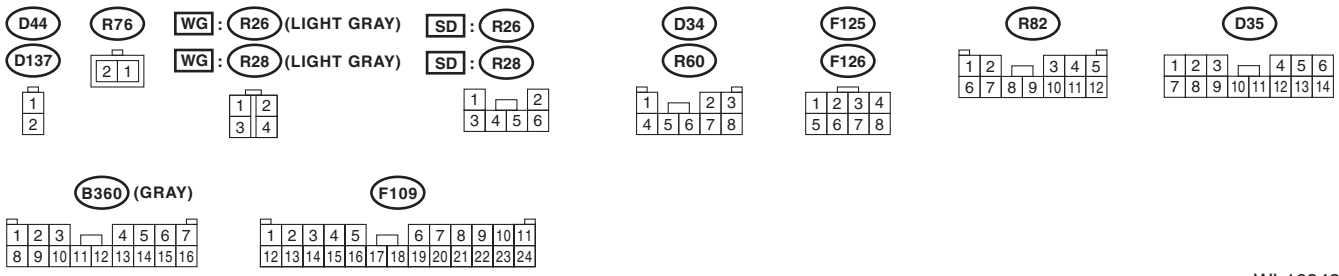
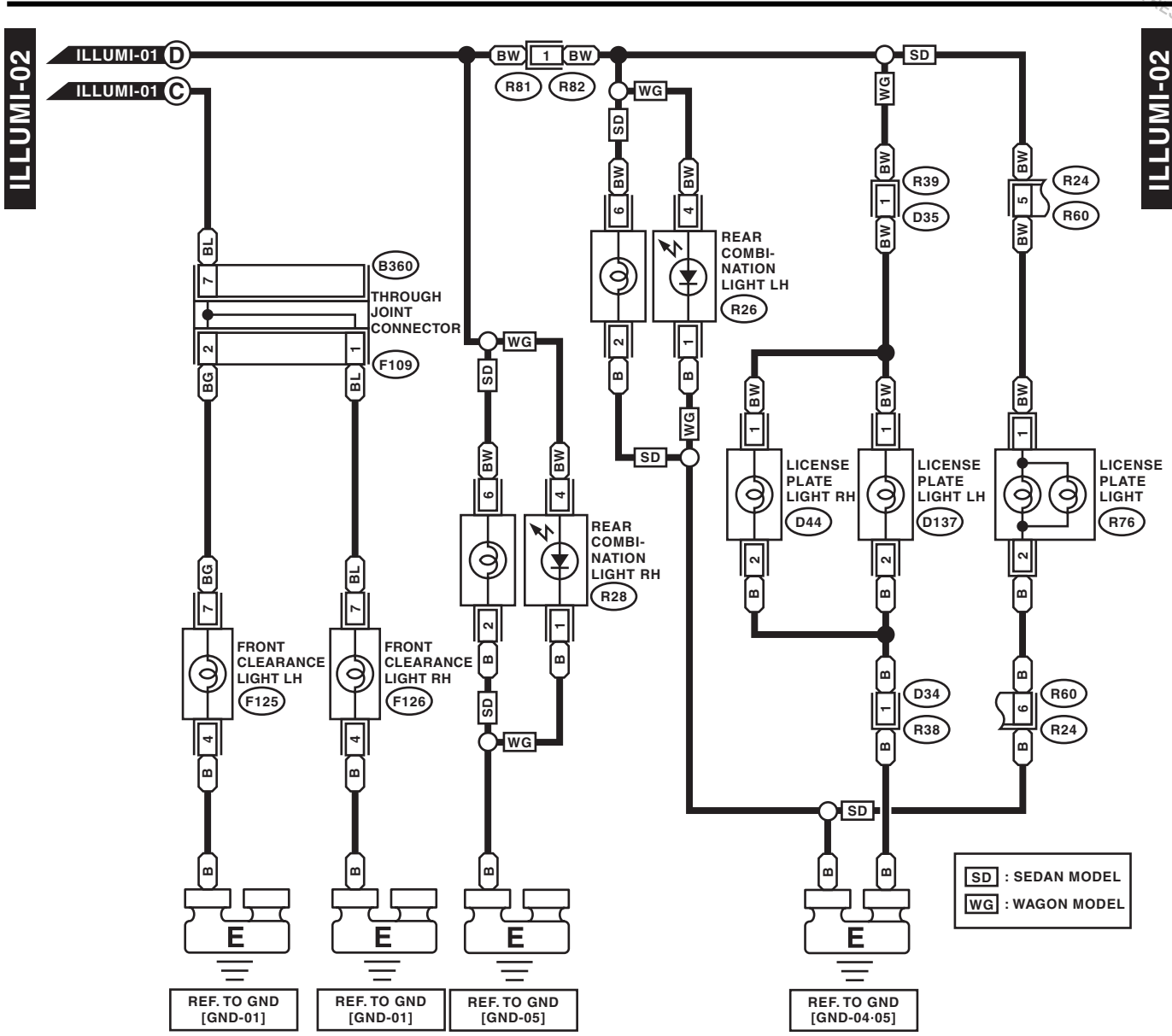

WI-16942

# Clearance Light and Illumination Light System

Brought to you by Eris Studios  
NOT FOR RESALE

WIRING SYSTEM

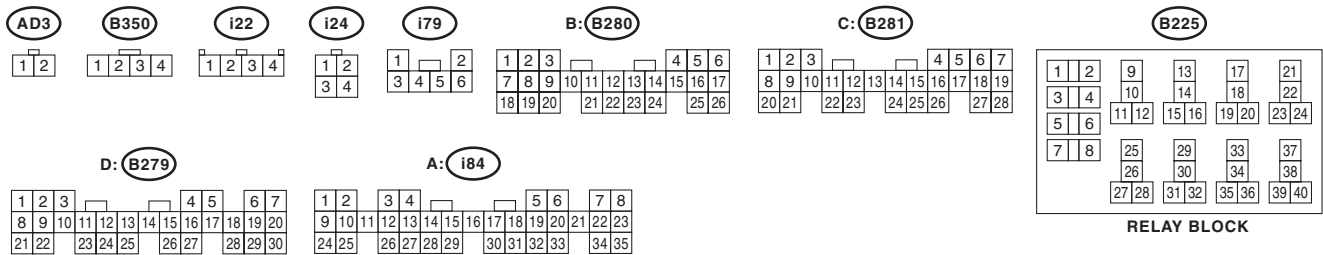
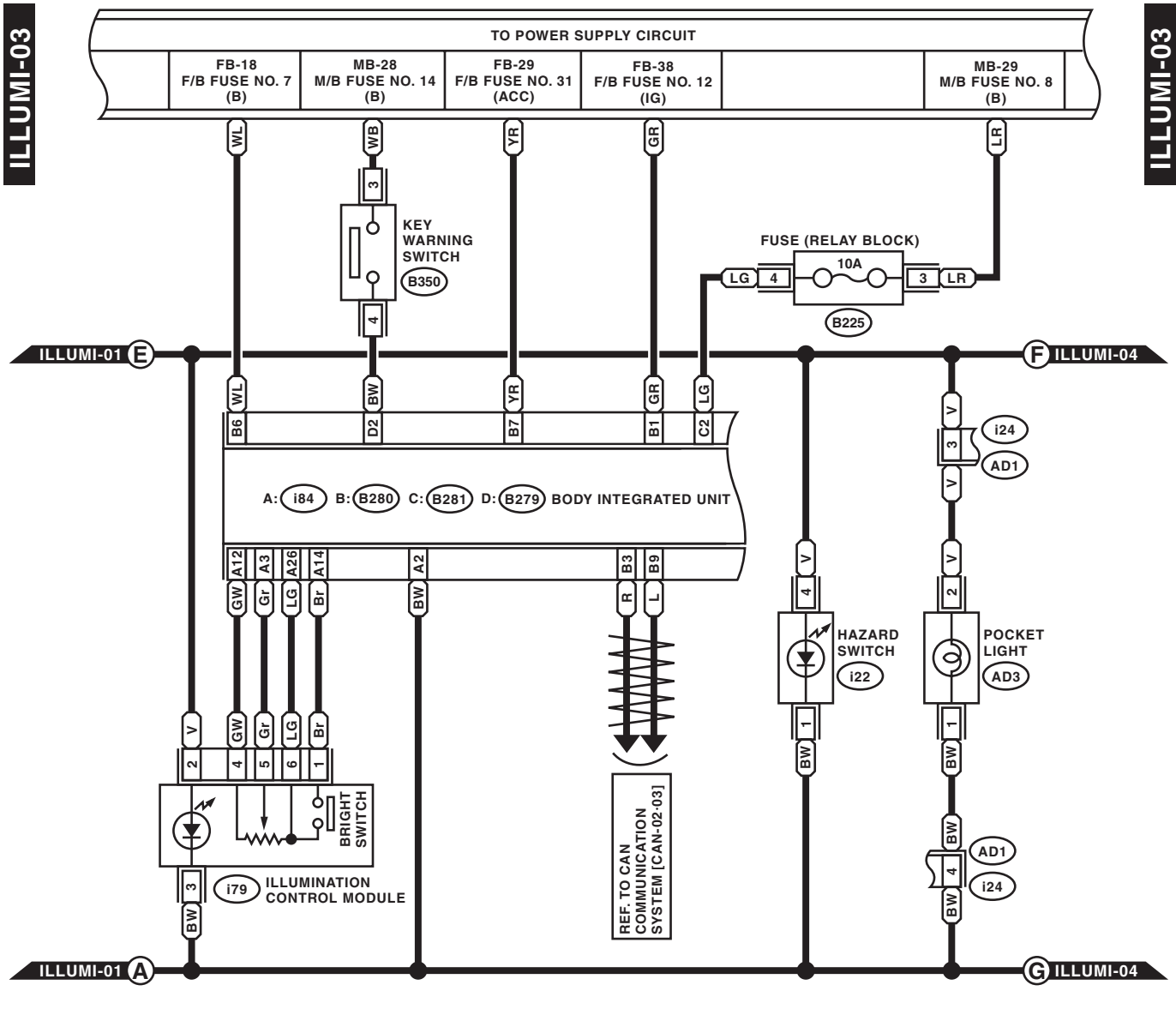

WI-17088

# Clearance Light and Illumination Light System

WIRING SYSTEM

Brought to you by *Autospin Studios*  
 NOT FOR SALE

ILLUMI-04

ILLUMI-04

MA : MANUAL A/C  
 AA : AUTO A/C  
 \*1 : TERMINAL No. OPTIONAL ARRANGEMENT

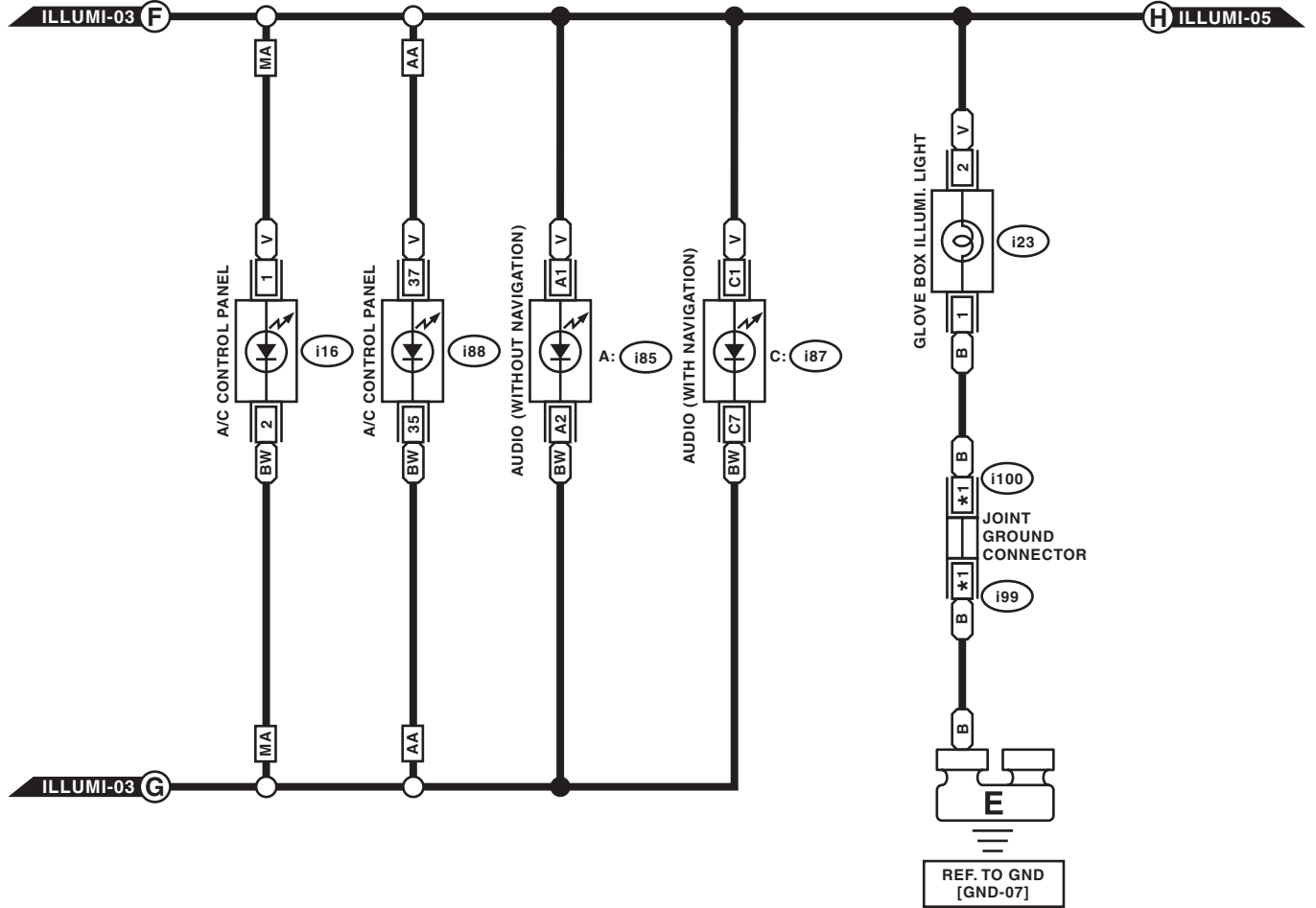

i23



i99

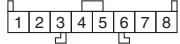

i100

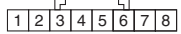

i16

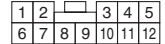

C: i87



A: i85

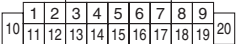

i88

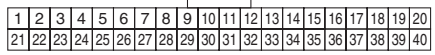

WI-16943

# Clearance Light and Illumination Light System

Brought to you by Eris Studios  
NOT FOR RESALE

## WIRING SYSTEM

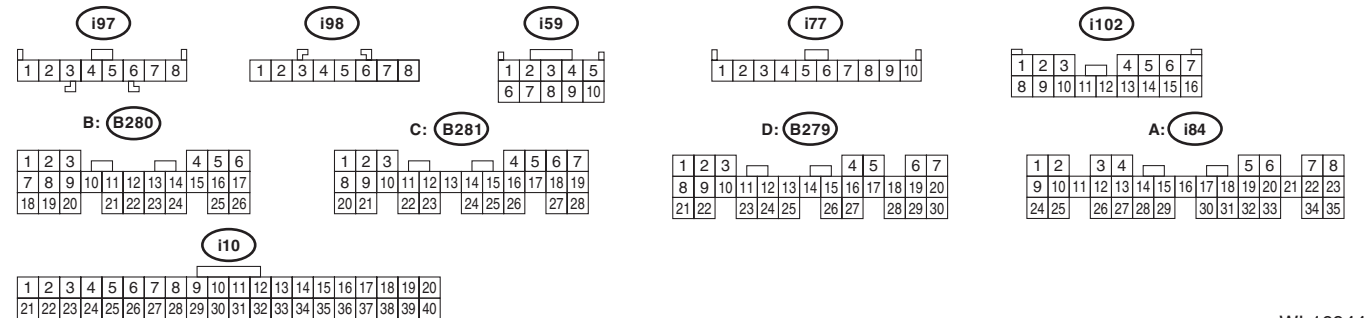
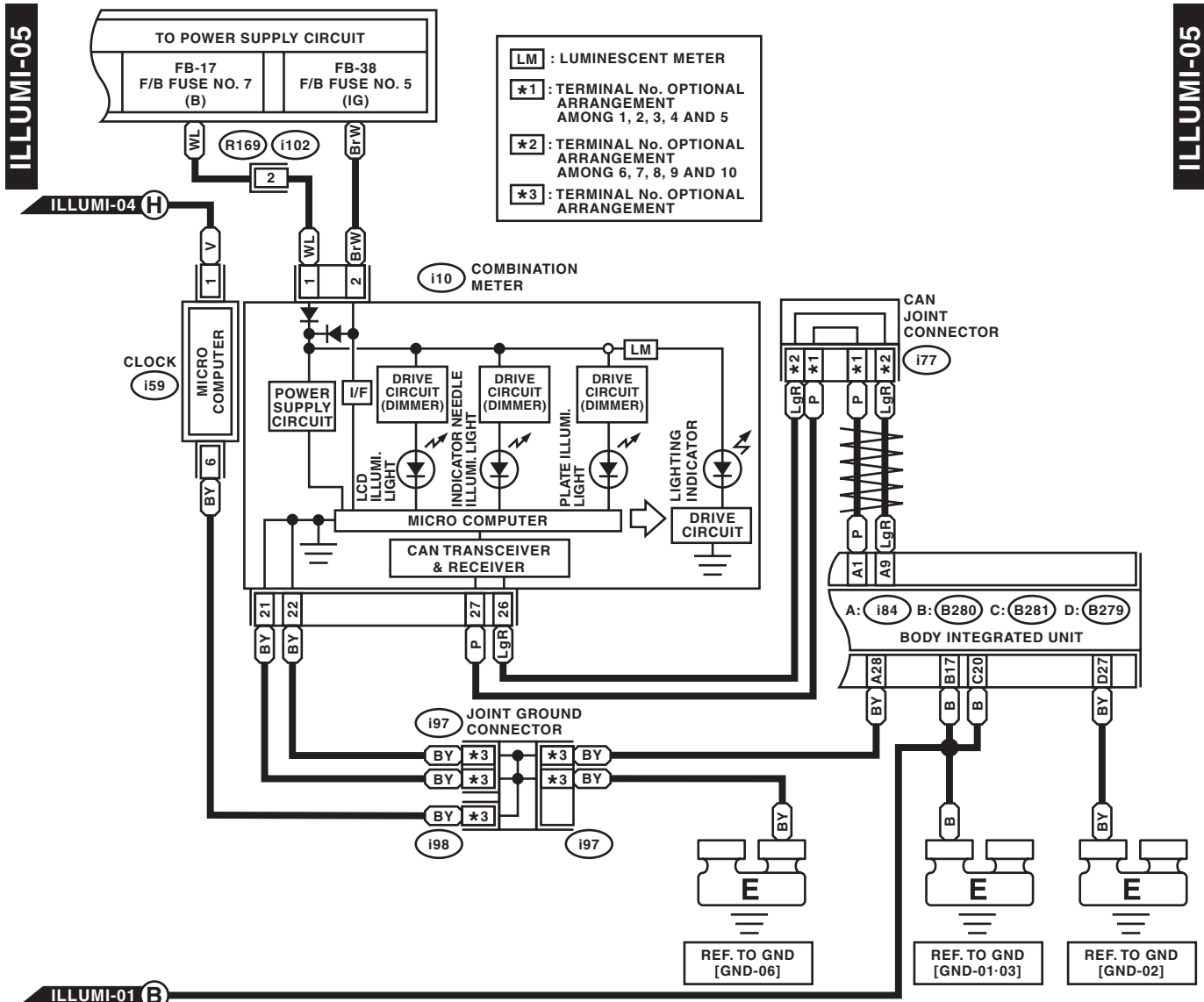

WI-16944



# Turn Signal Light and Hazard Light System

WIRING SYSTEM

Brought to you by  
NOVUS Studios  
NOT FOR SALE

## 25. Turn Signal Light and Hazard Light System

### A: WIRING DIAGRAM

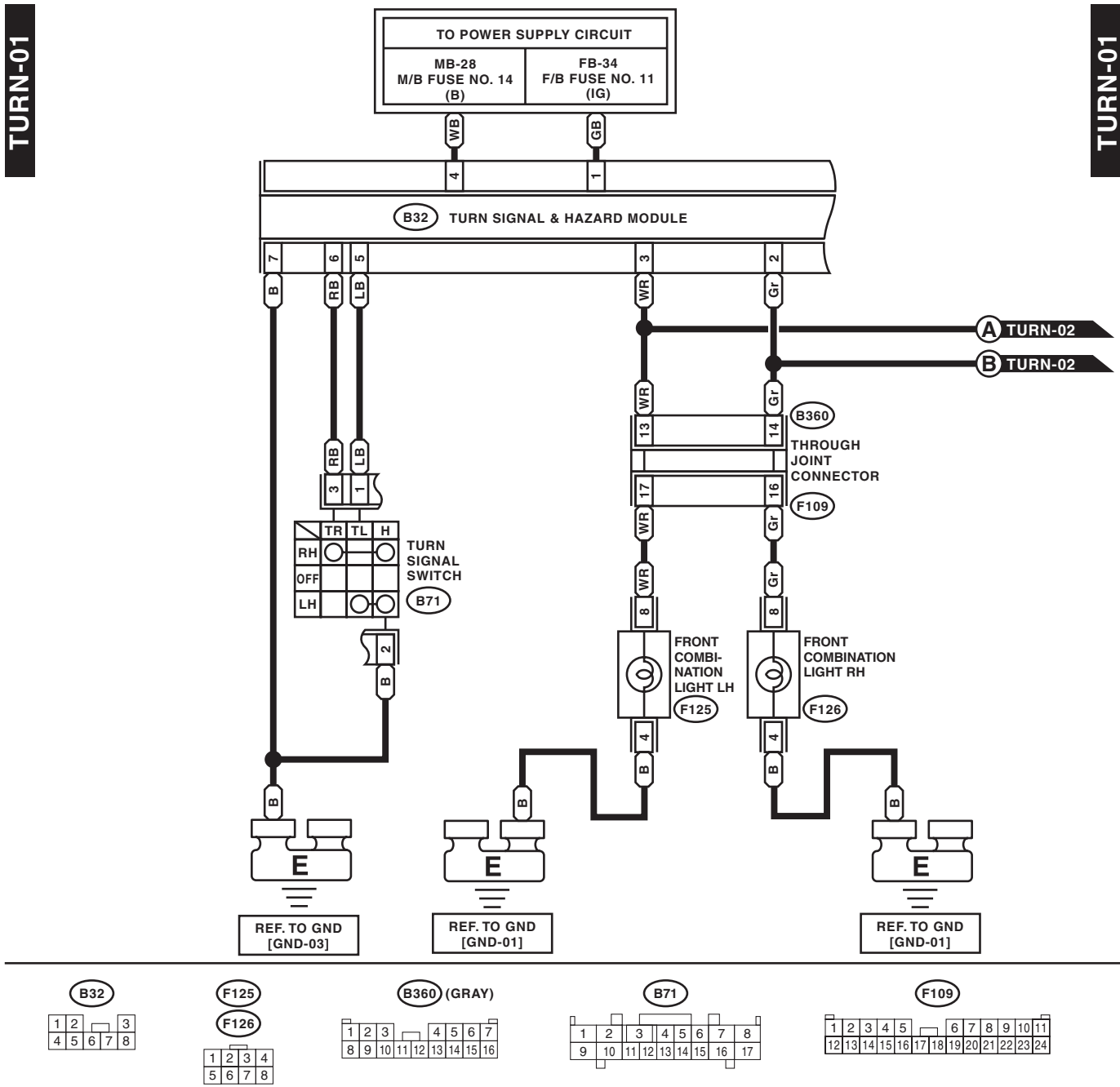

WI-16945

# Turn Signal Light and Hazard Light System

Brought to you by Eris Studios  
NOT FOR RESALE

WIRING SYSTEM

TURN-02

TURN-02

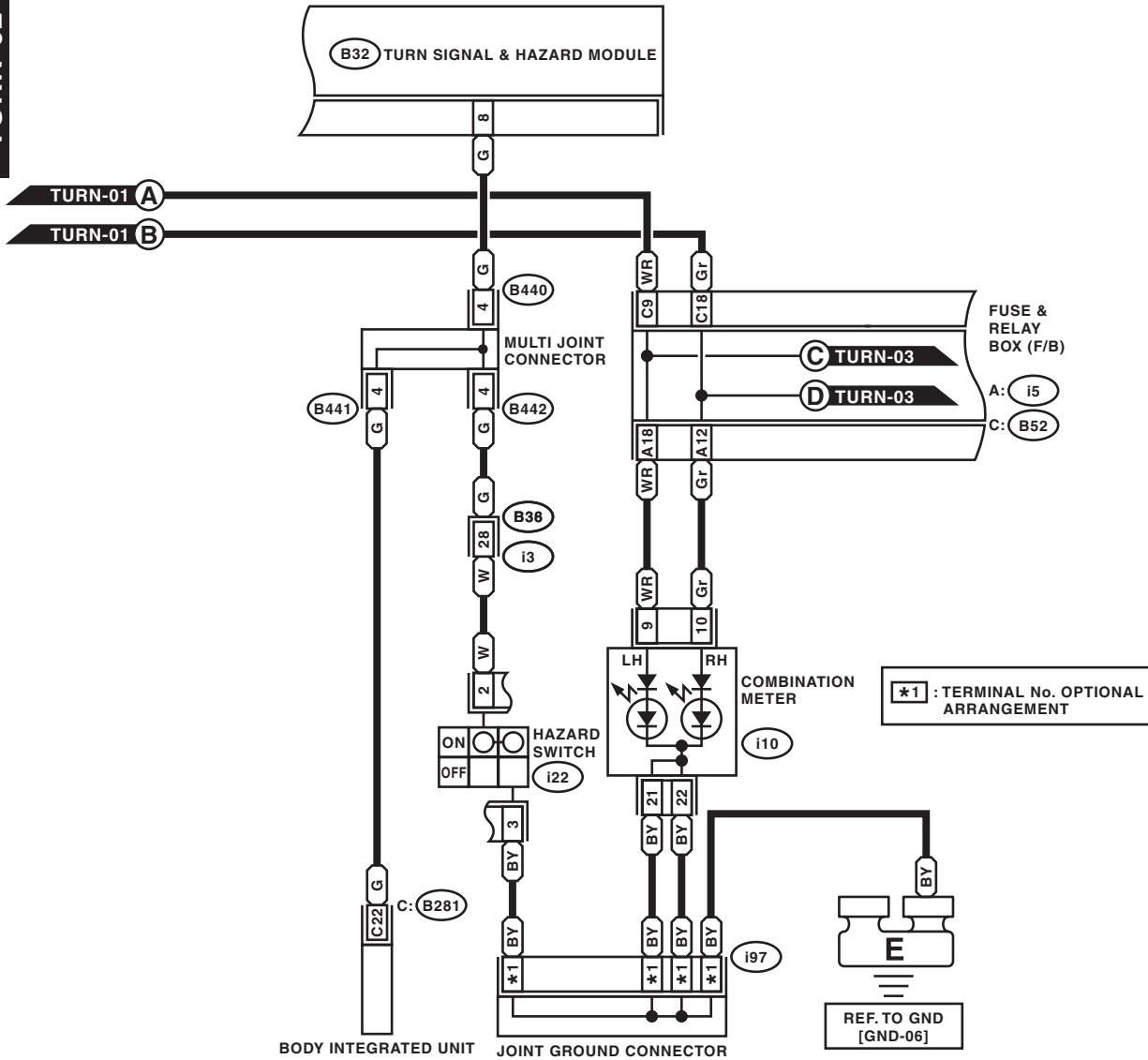

\*1 : TERMINAL No. OPTIONAL ARRANGEMENT

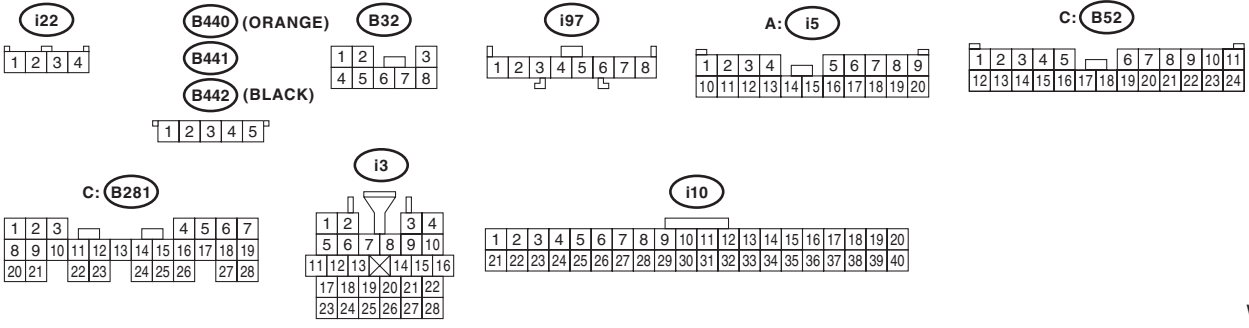

WI-16946

# Turn Signal Light and Hazard Light System

WIRING SYSTEM

Brought to you by *Chris Studios*  
NOT FOR SALE

TURN-03

TURN-03

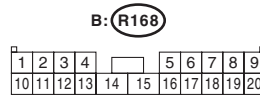
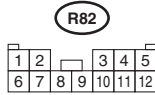
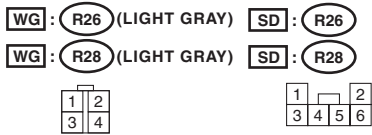
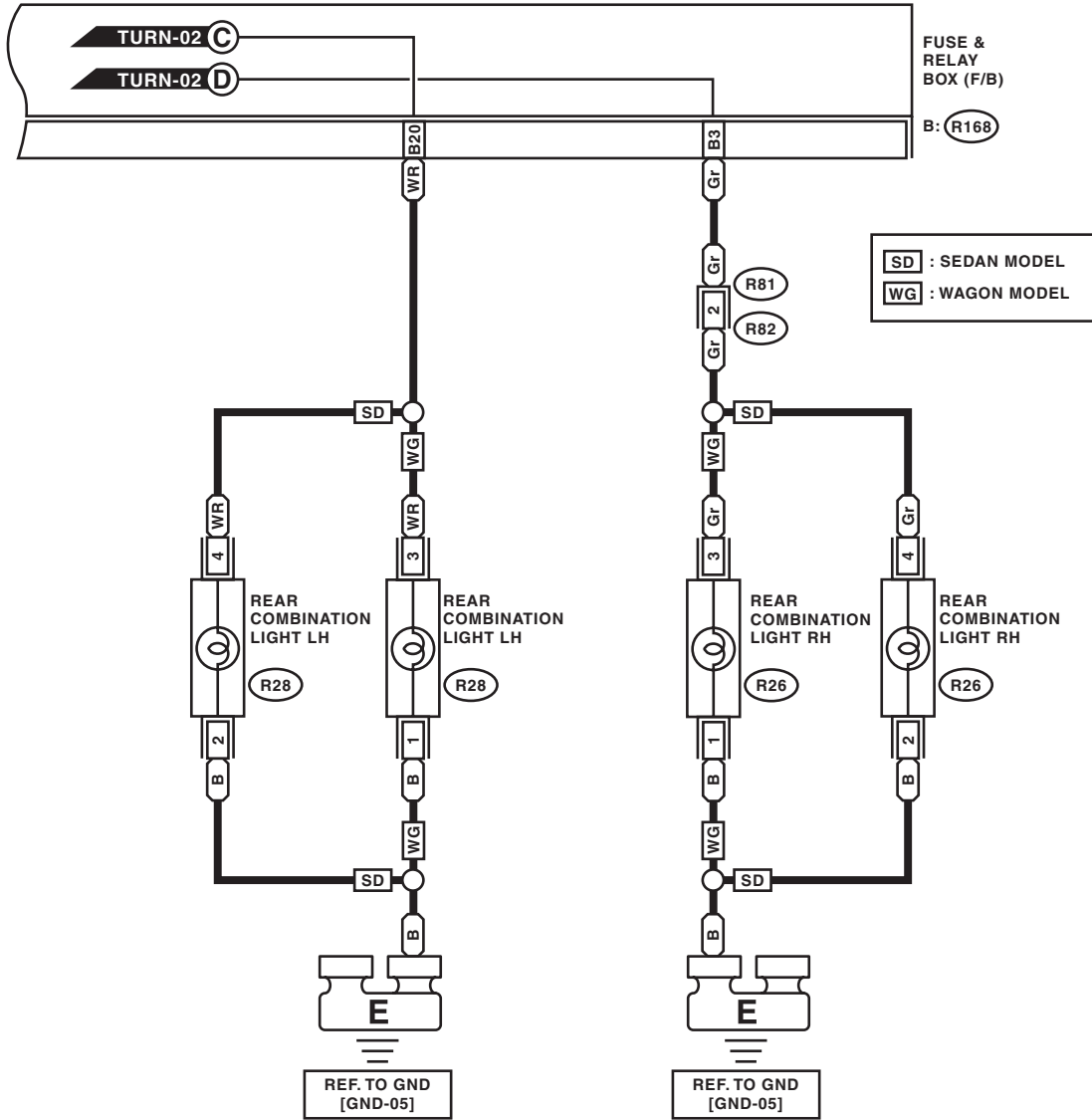

WI-16947

# Interior Light System

Brought to you by Eris Studios  
NOT FOR RESALE

WIRING SYSTEM

## 26. Interior Light System

### A: WIRING DIAGRAM

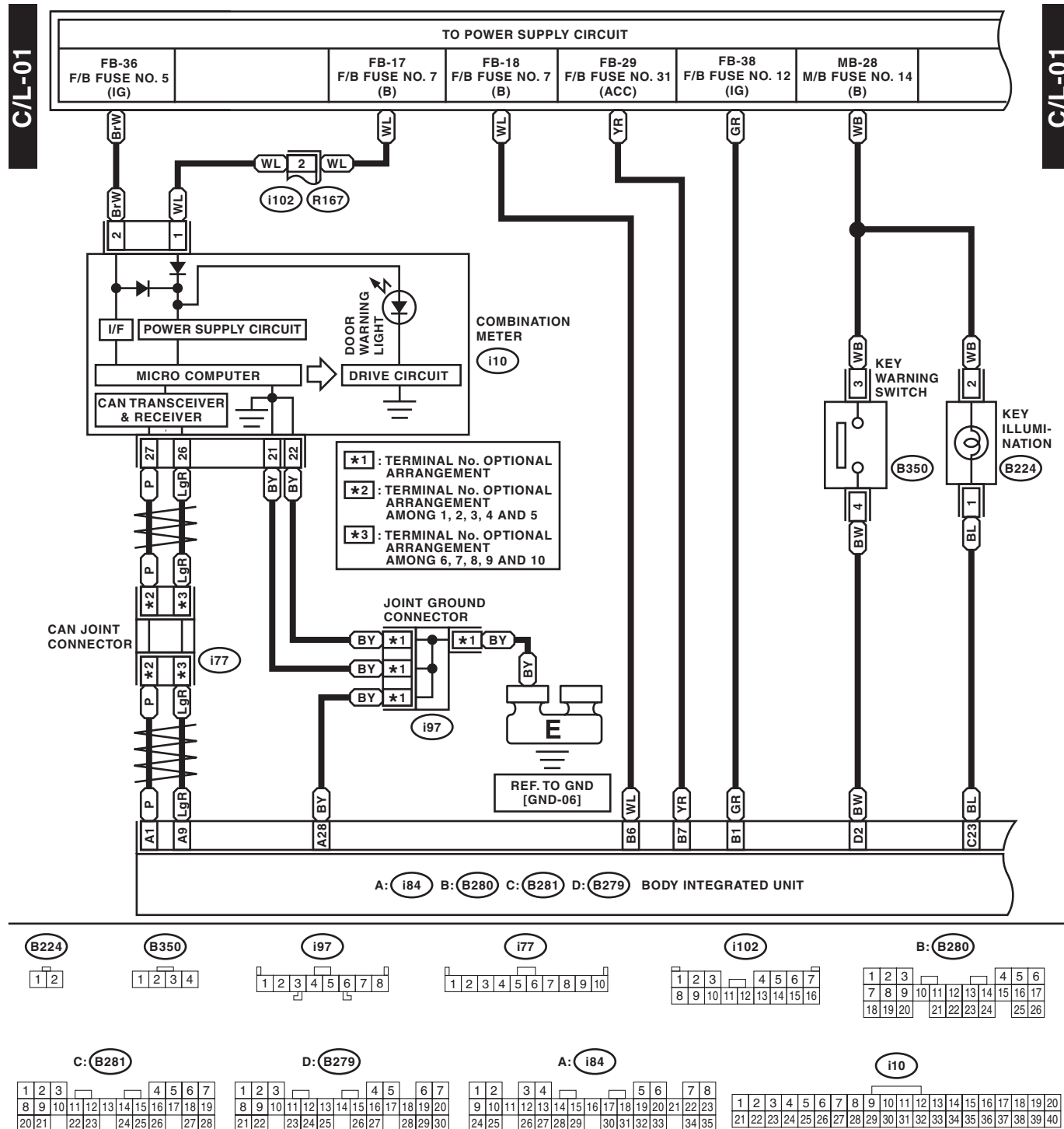

WI-16948

# Interior Light System

WIRING SYSTEM

Brought to you by *Chris Studios*  
NOT FOR SALE

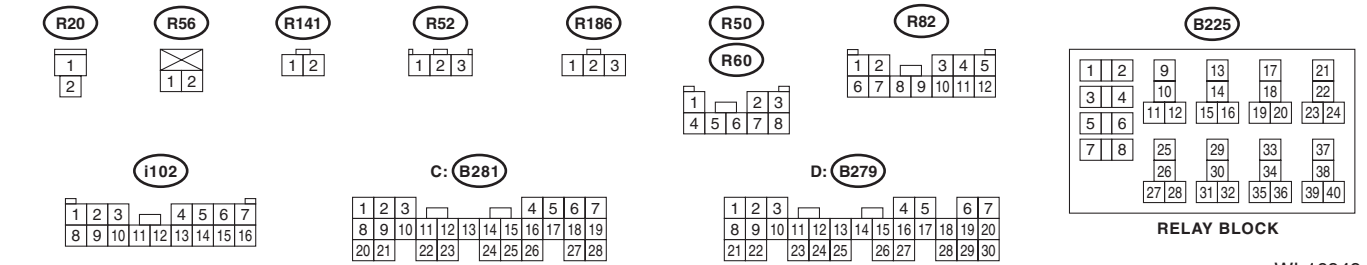
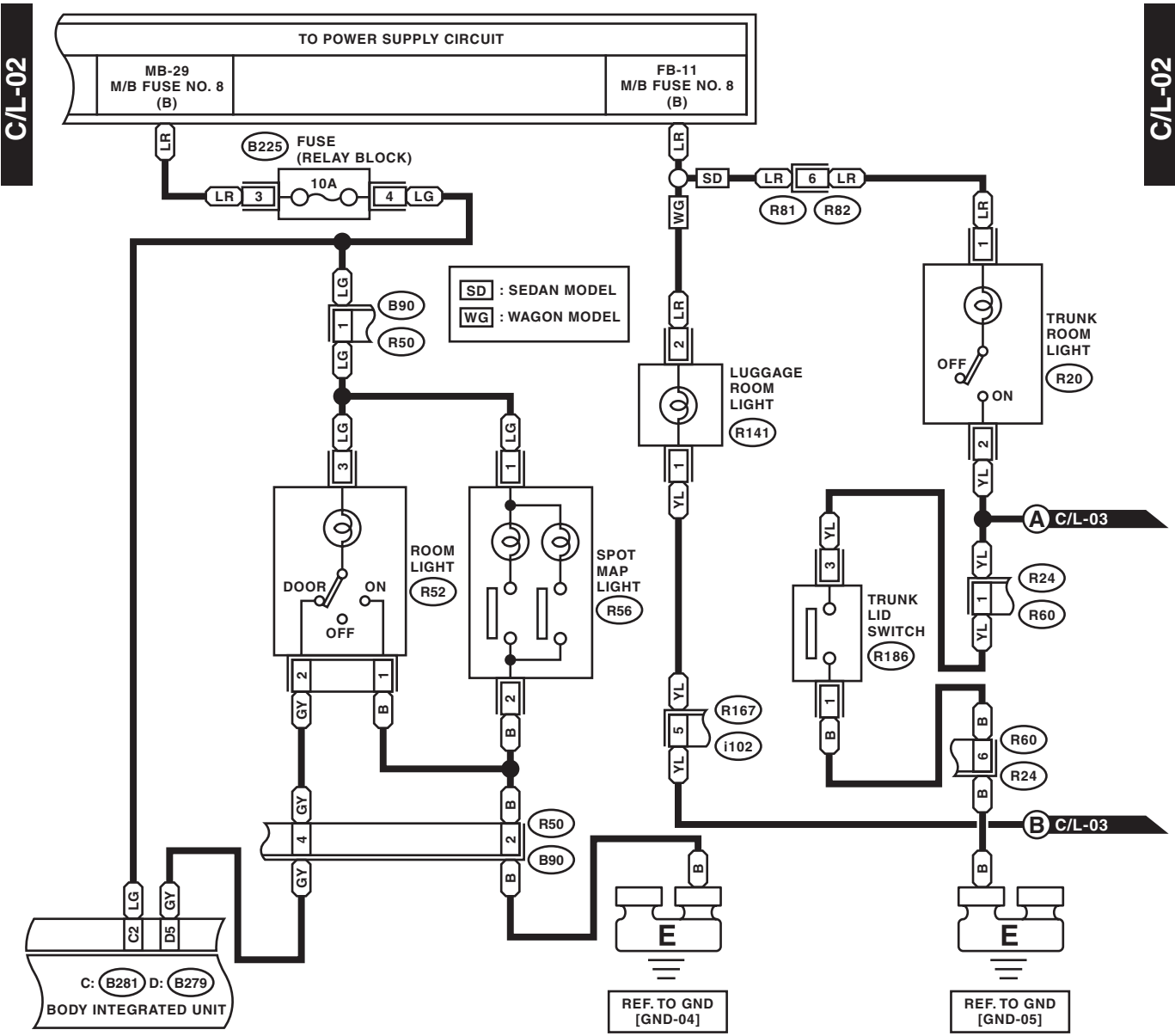

WI-16949

# Interior Light System

WIRING SYSTEM

Brought to you by Eris Studios  
NOT FOR RESALE

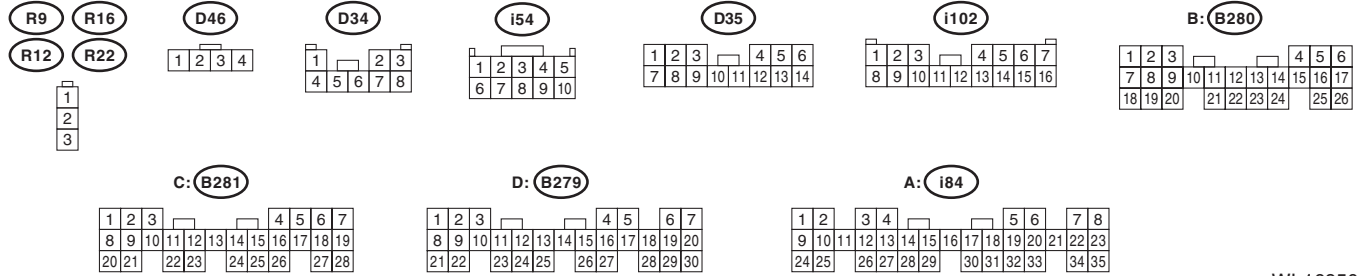
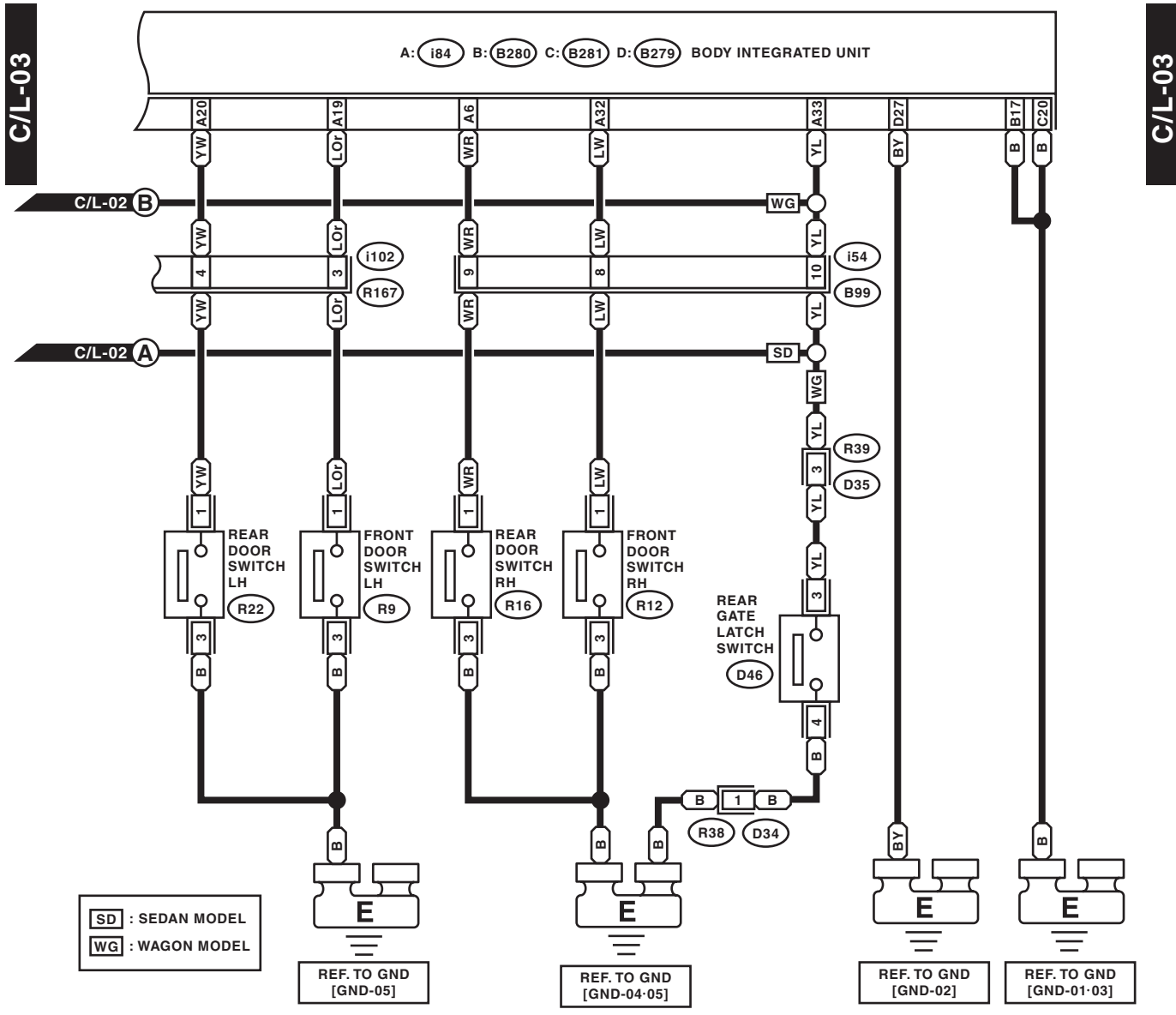

WI-16950

## 27. Front Wiper and Washer System

### A: WIRING DIAGRAM

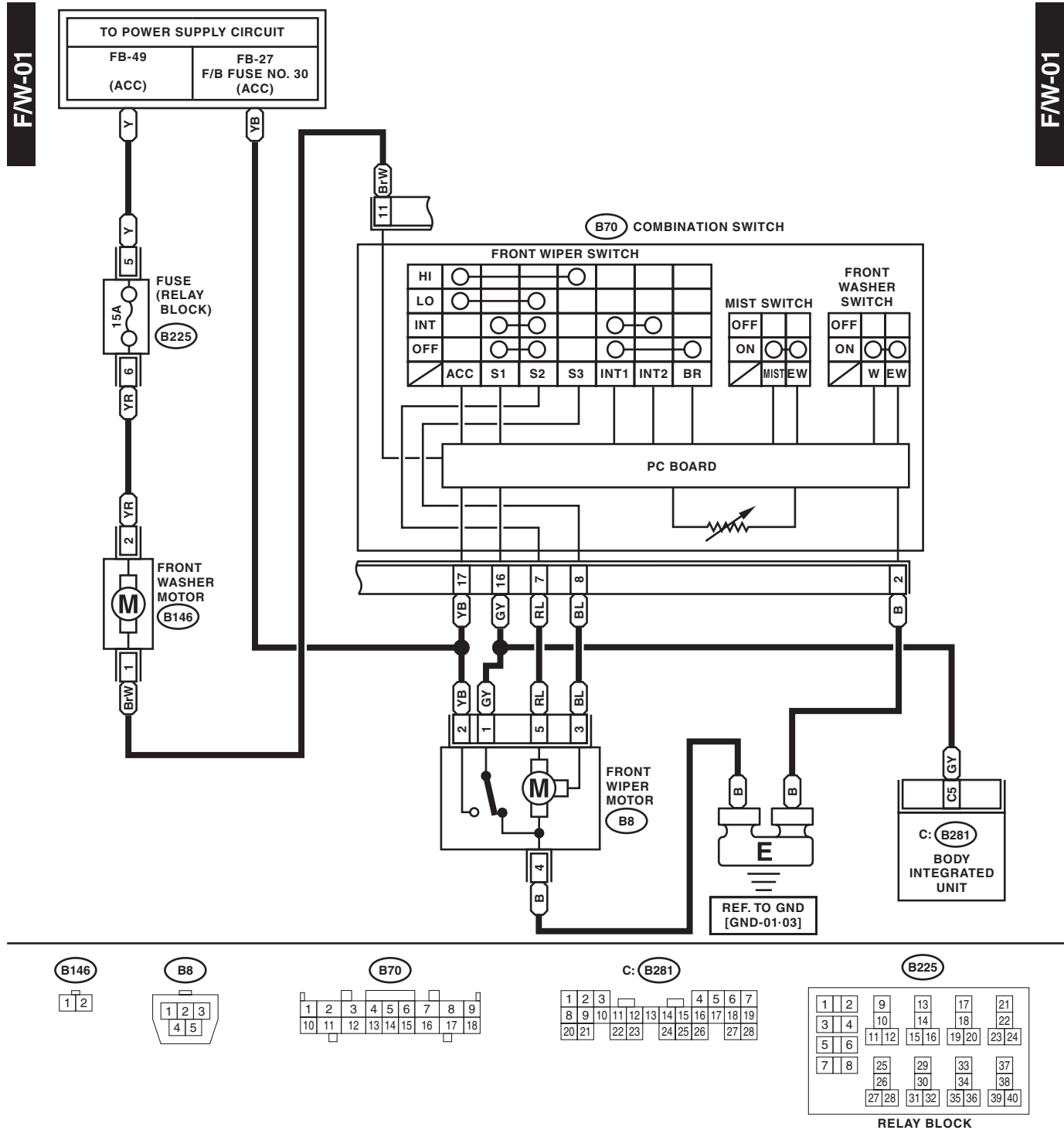

WI-16951

# Rear Wiper and Washer System

WIRING SYSTEM

Brought to you by Eris Studios  
NOT FOR RESALE

## 28. Rear Wiper and Washer System

### A: WIRING DIAGRAM

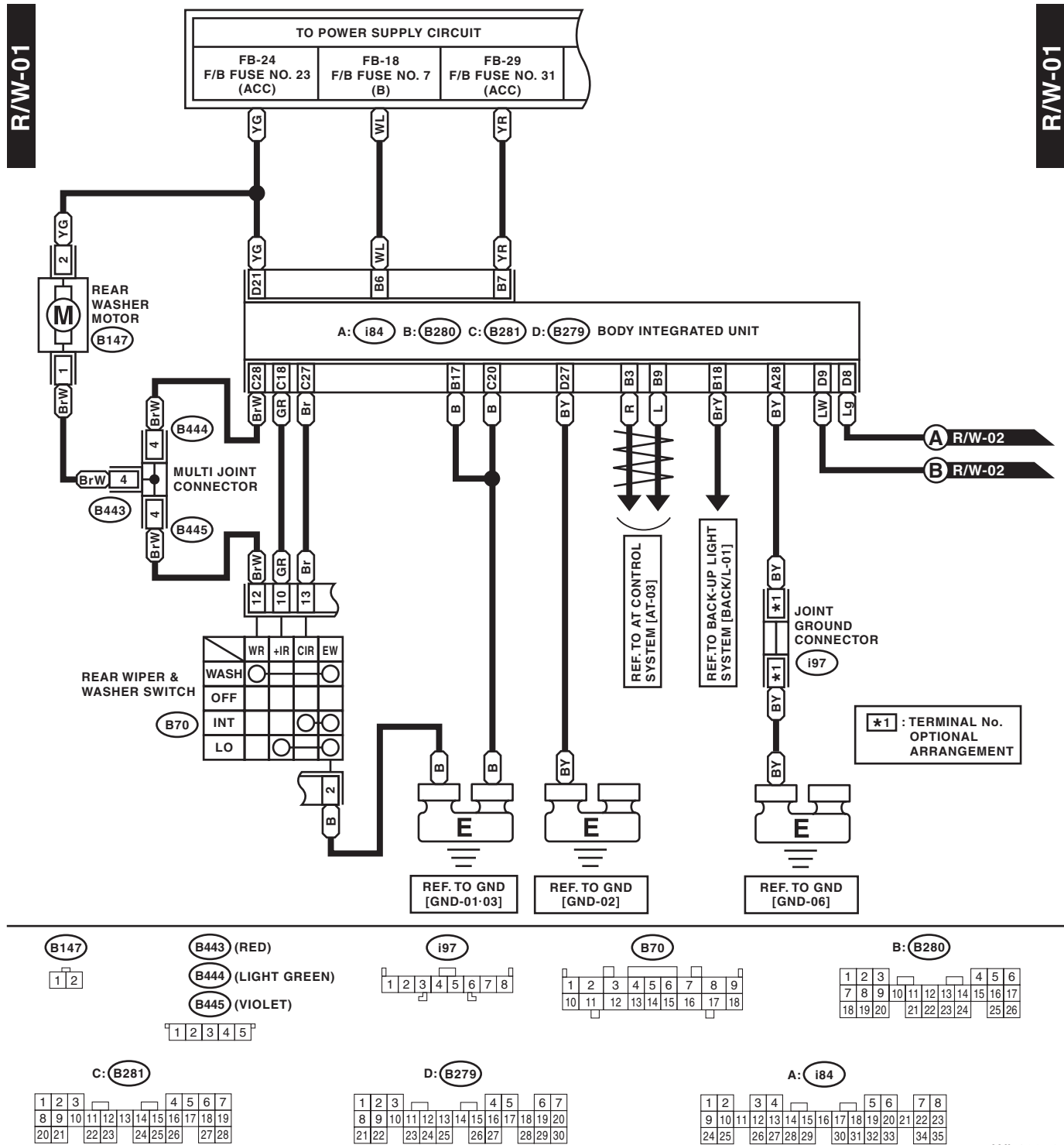

WI-16952



# Rear Wiper and Washer System

WIRING SYSTEM

Brought to you by *Chris Studios*  
NOT FOR SALE

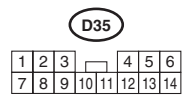
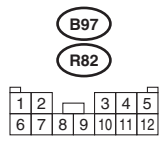
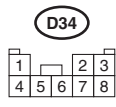
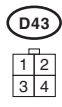
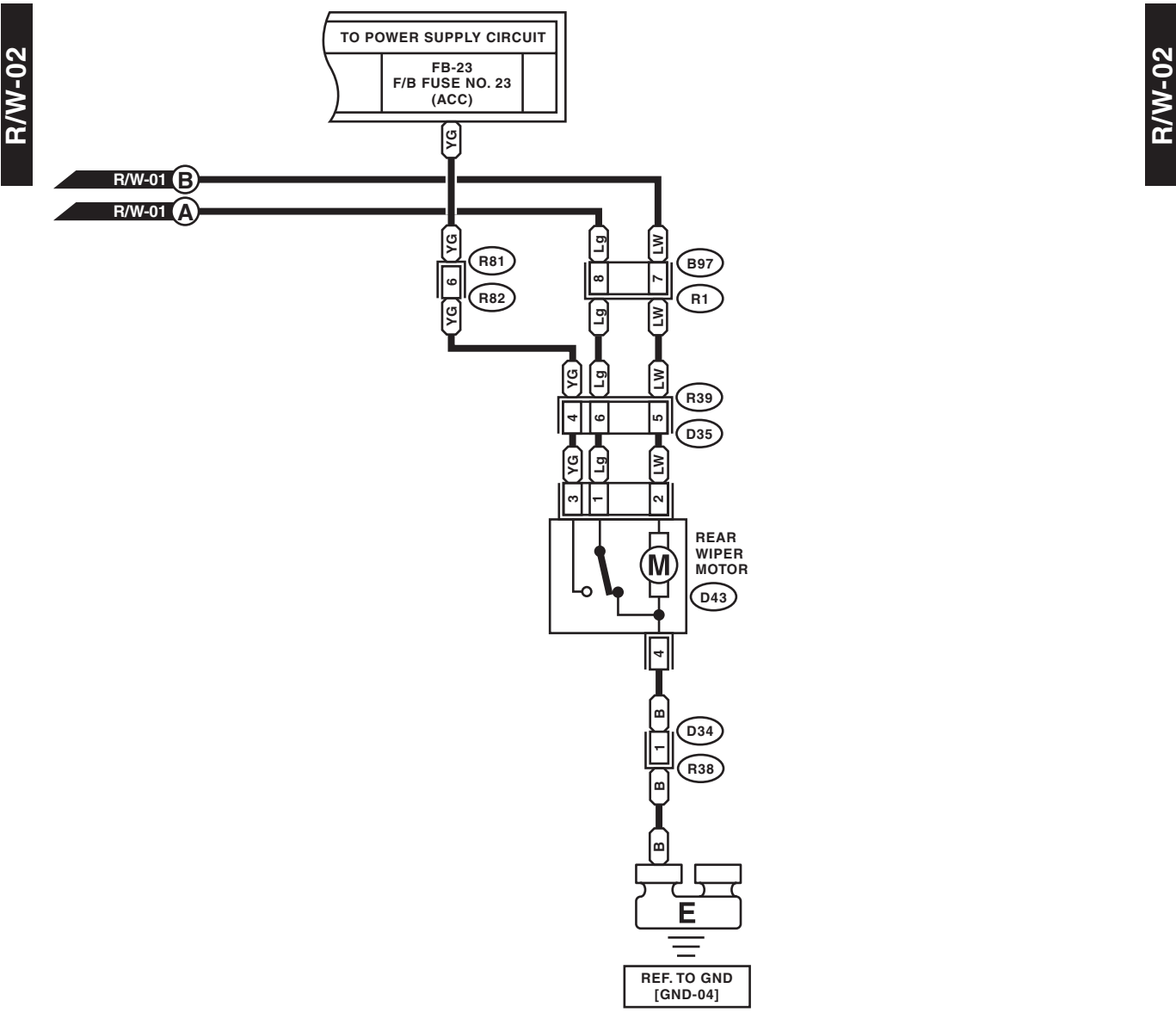

WI-16953

# Wiper Deicer System

Brought to you by Eris Studios  
NOT FOR RESALE

## WIRING SYSTEM

### 29. Wiper Deicer System

#### A: WIRING DIAGRAM

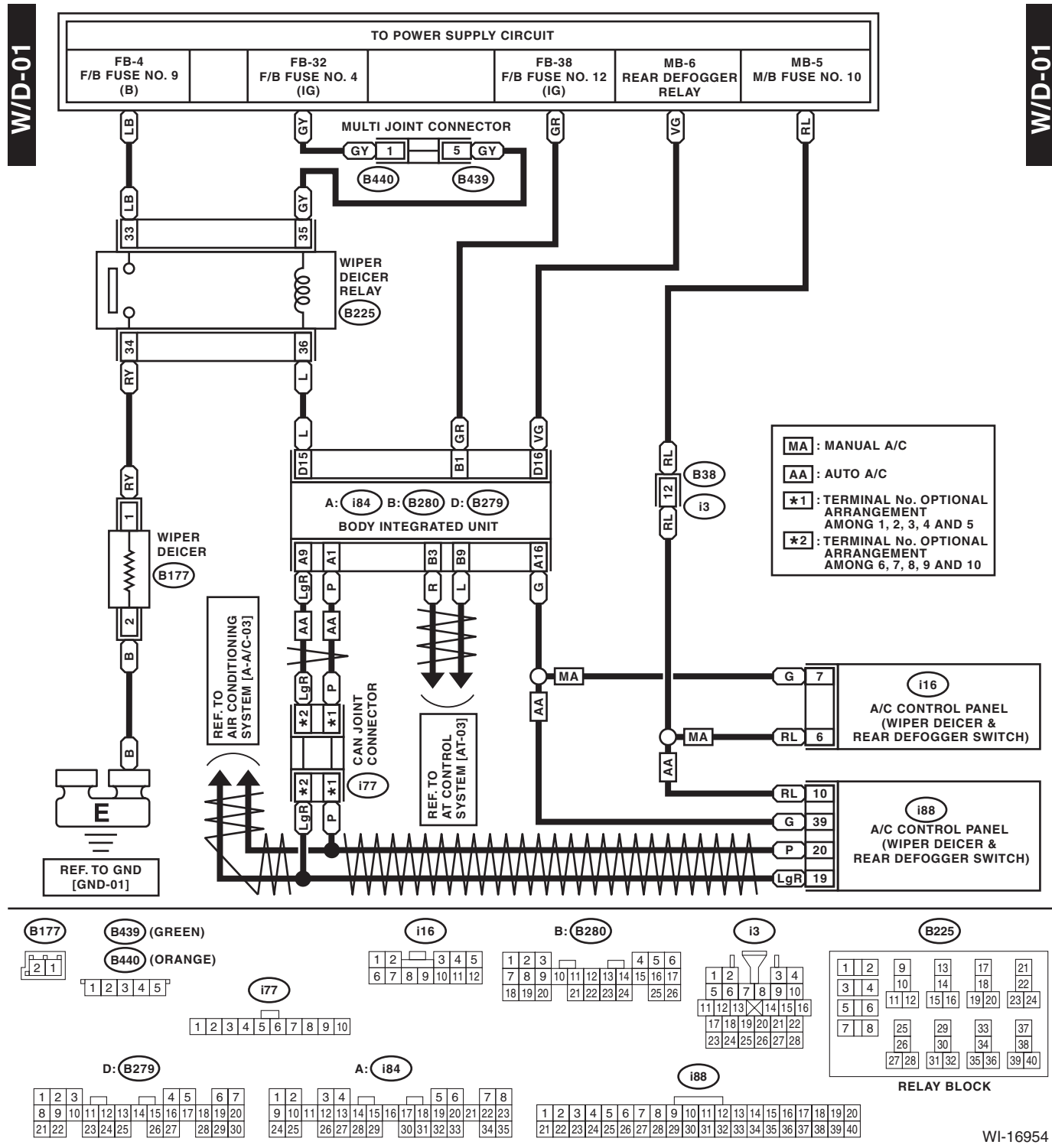

WI-16954

Brought to you by *Chris Studios*  
NOT FOR SALE

## 30. Audio System

### A: WIRING DIAGRAM

#### 1. MODELS WITHOUT NAVIGATION SYSTEM

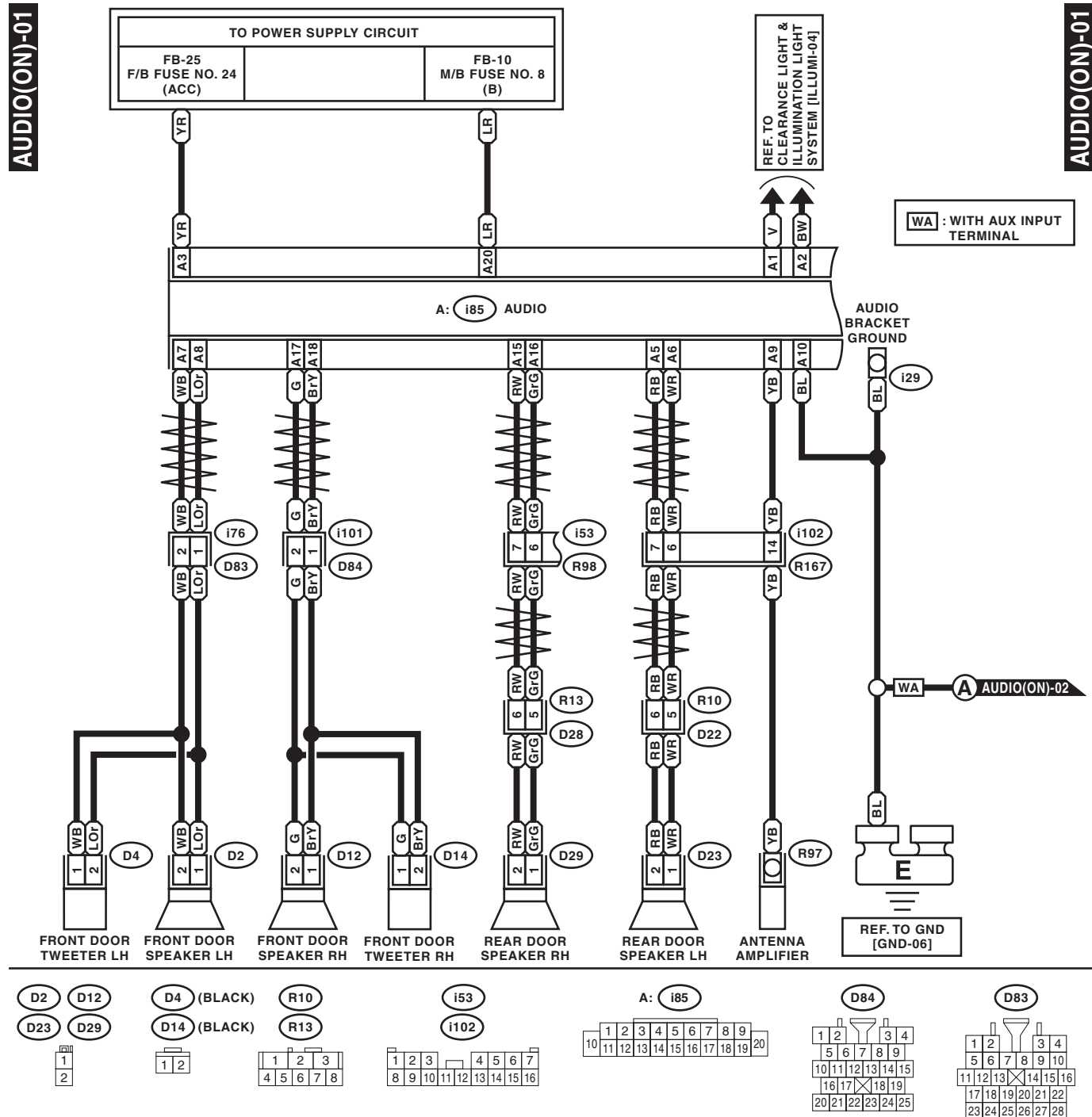

WI-16956

# Audio System

Brought to you by Eris Studios  
NOT FOR RESALE

WIRING SYSTEM

AUDIO(ON)-02

AUDIO(ON)-02

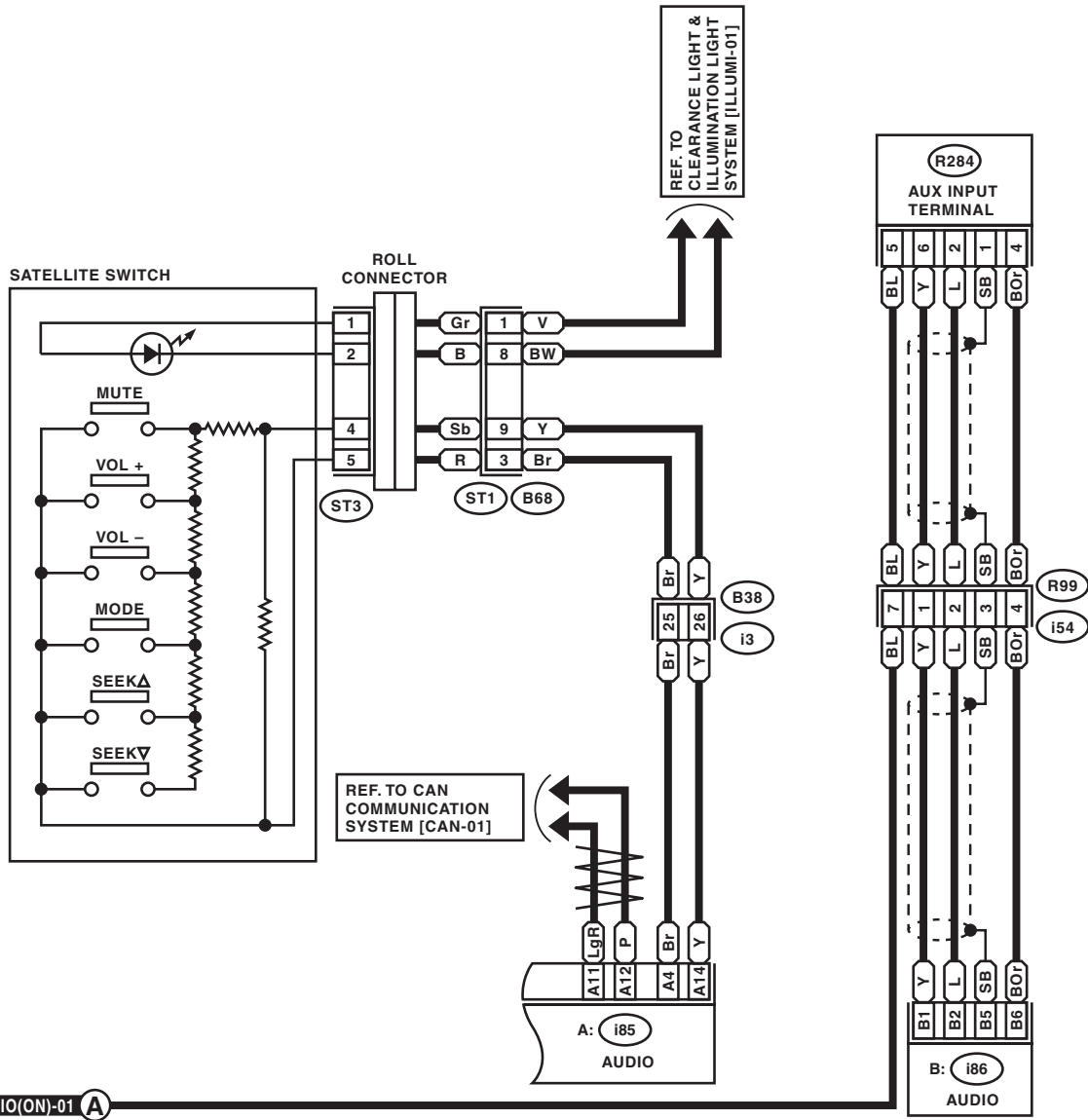

AUDIO(ON)-01 A

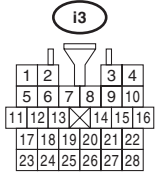
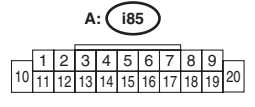
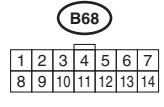
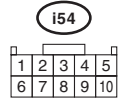
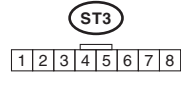

WI-16957

Brought to you by Chris Studios  
 NOT FOR SALE

### 2. MODELS WITH NAVIGATION SYSTEM

AUDIO(WN)-01

AUDIO(WN)-01

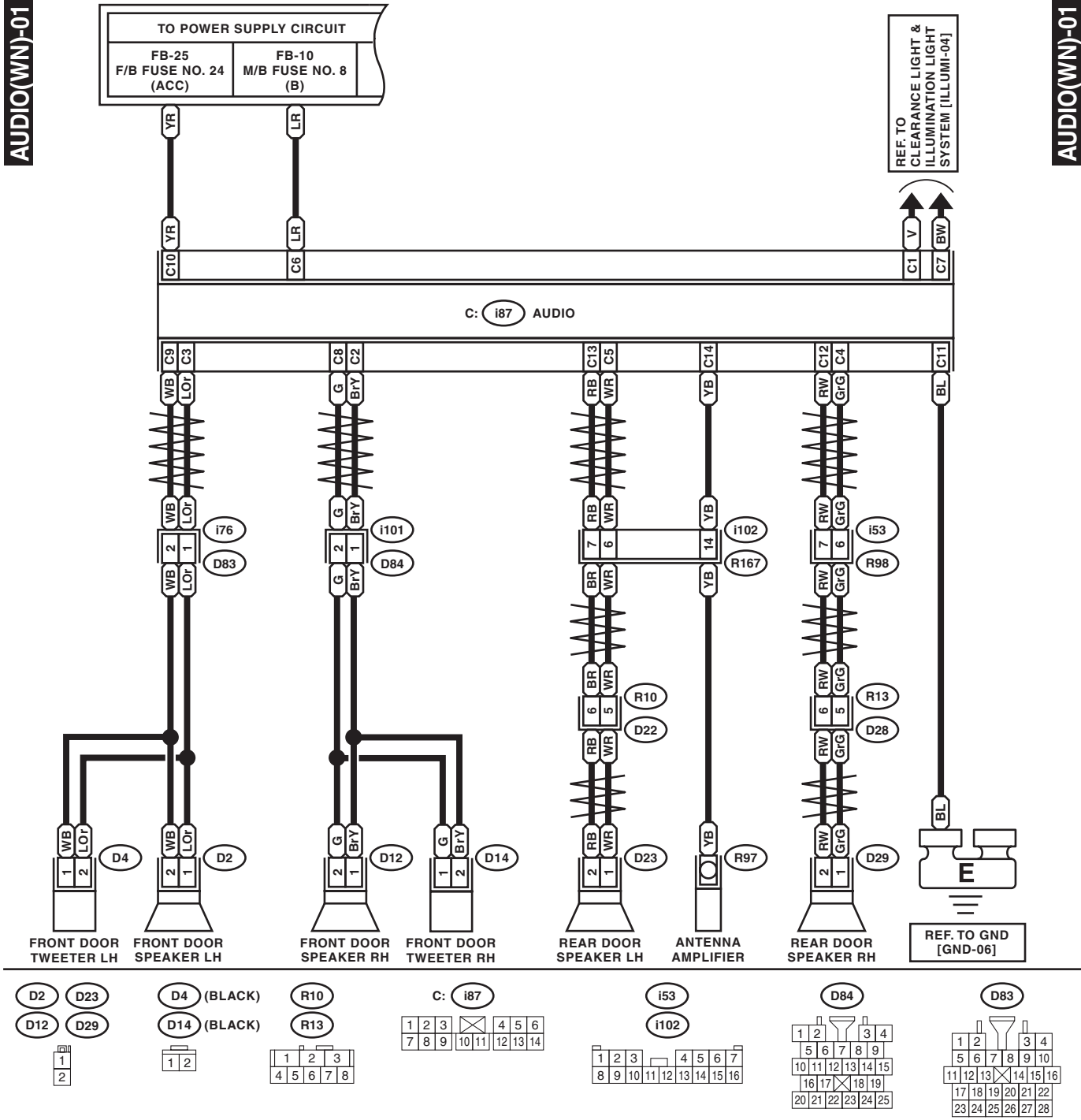

WI-16955

# Audio System

WIRING SYSTEM

Brought to you by Eris Studios  
NOT FOR RESALE

AUDIO(WN)-02

AUDIO(WN)-02

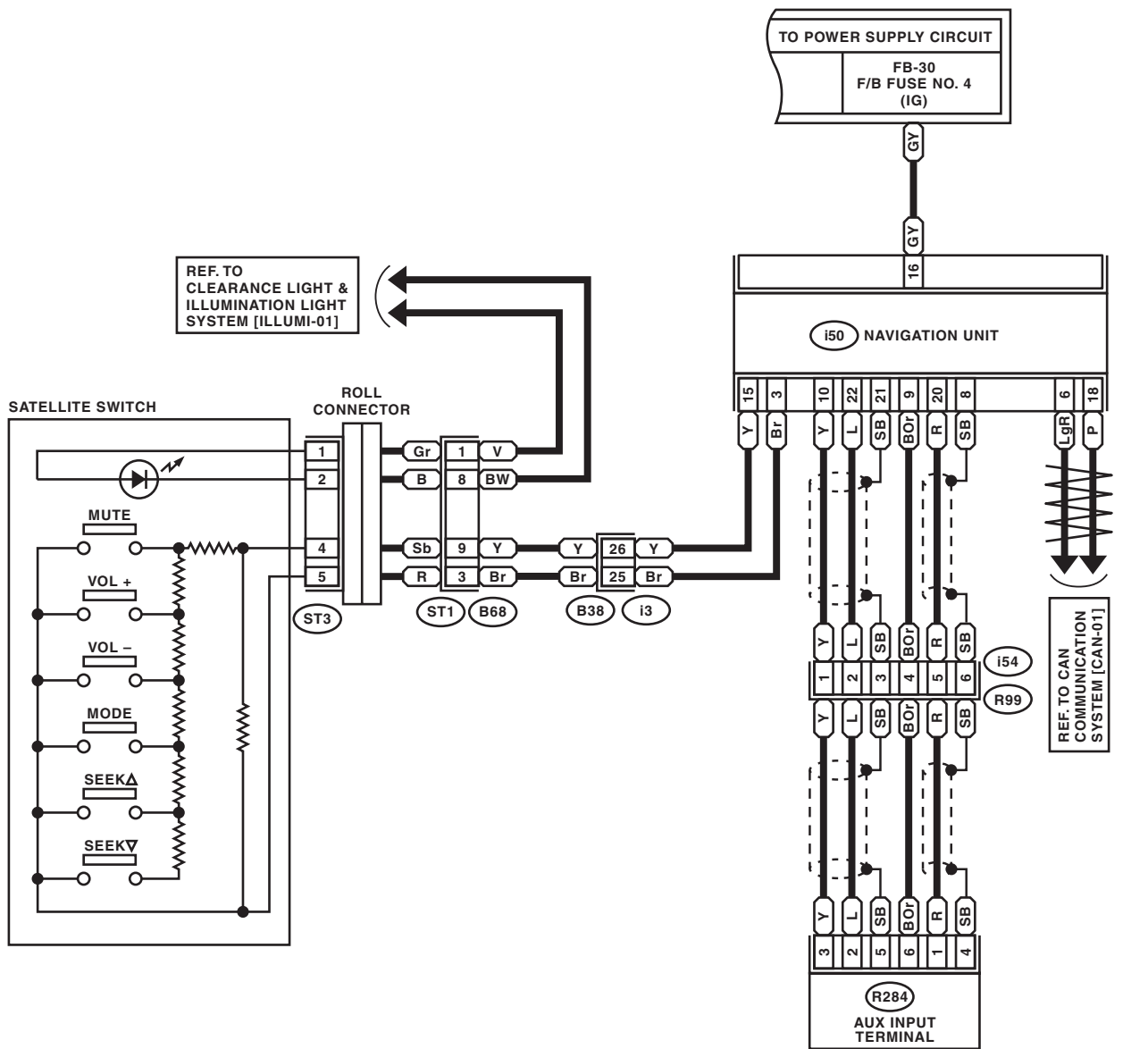

REF. TO CLEARANCE LIGHT & ILLUMINATION LIGHT SYSTEM [ILLUMI-01]

REF. TO CAN COMMUNICATION SYSTEM [CAN-01]

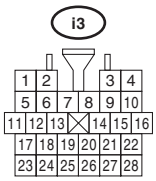
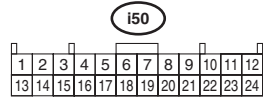
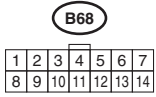
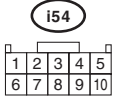
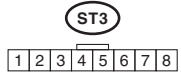
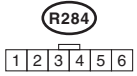

WI-17029

## 31. Front Accessory Power Supply Socket System

### A: WIRING DIAGRAM

FAPS-01

FAPS-01

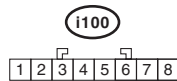
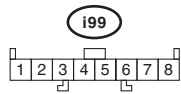
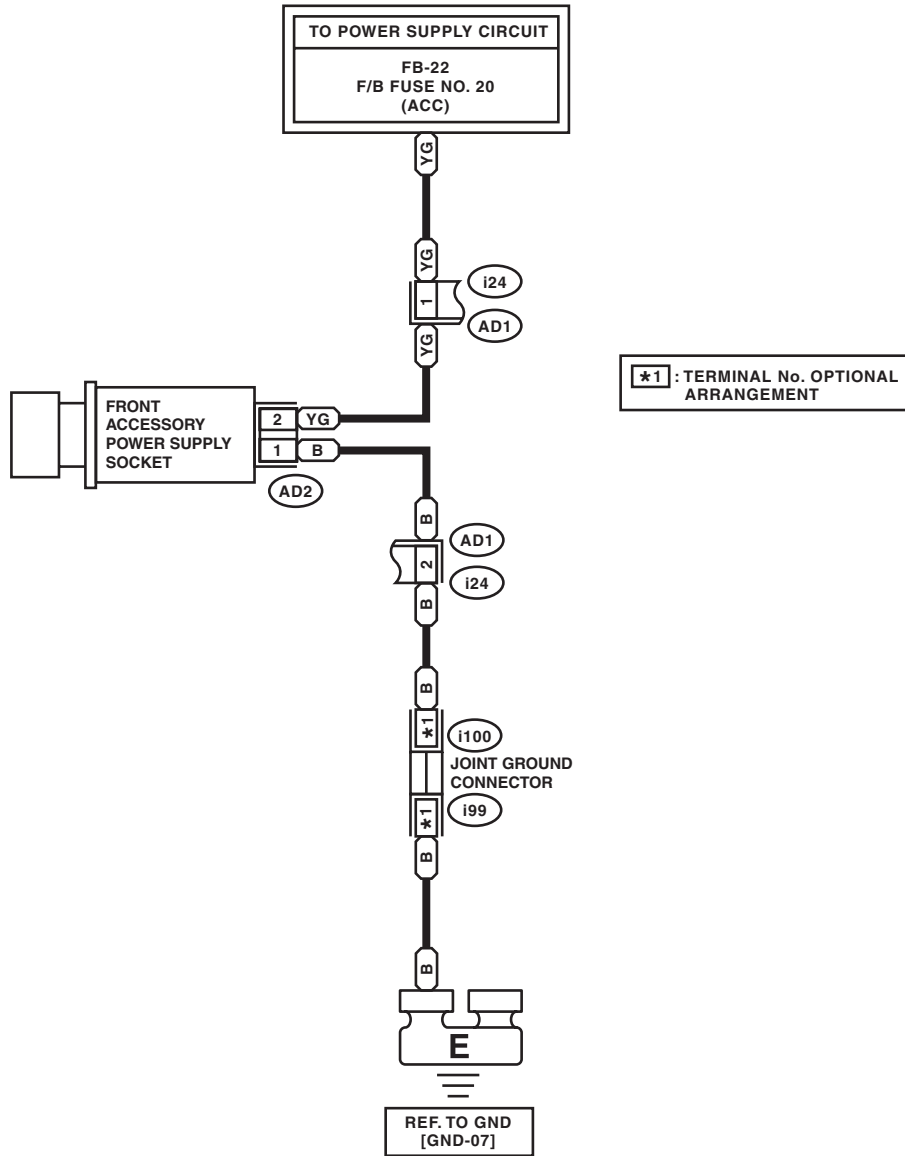

# Rear Accessory Power Supply Socket System

WIRING SYSTEM

Brought to you by Eris Studios  
NOT FOR RESALE

## 32.Rear Accessory Power Supply Socket System

### A: WIRING DIAGRAM

RAPS-01

RAPS-01

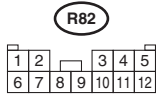
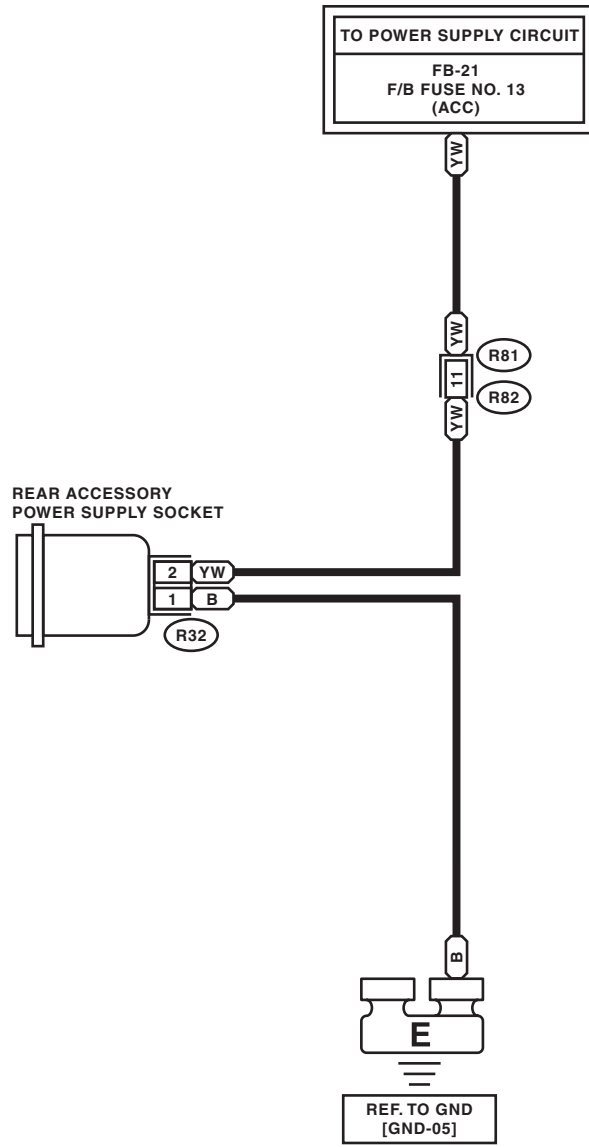

WI-16959



Brought to you by **Chris Studios**  
NOT FOR SALE

## 33. Navigation System

### A: WIRING DIAGRAM

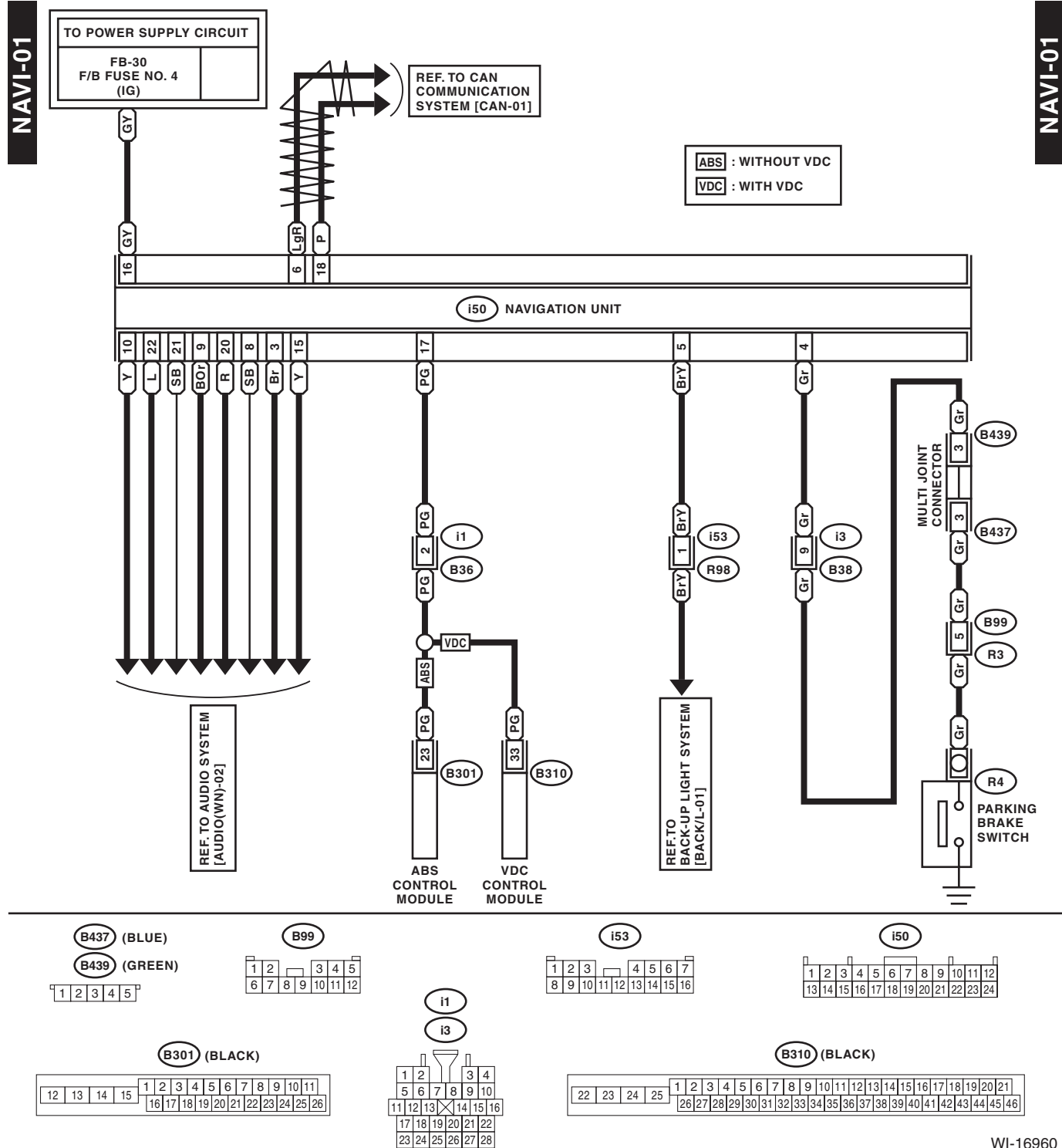

WI-16960

# Horn System

WIRING SYSTEM

Brought to you by Eris Studios  
NOT FOR RESALE

## 34.Horn System

### A: WIRING DIAGRAM

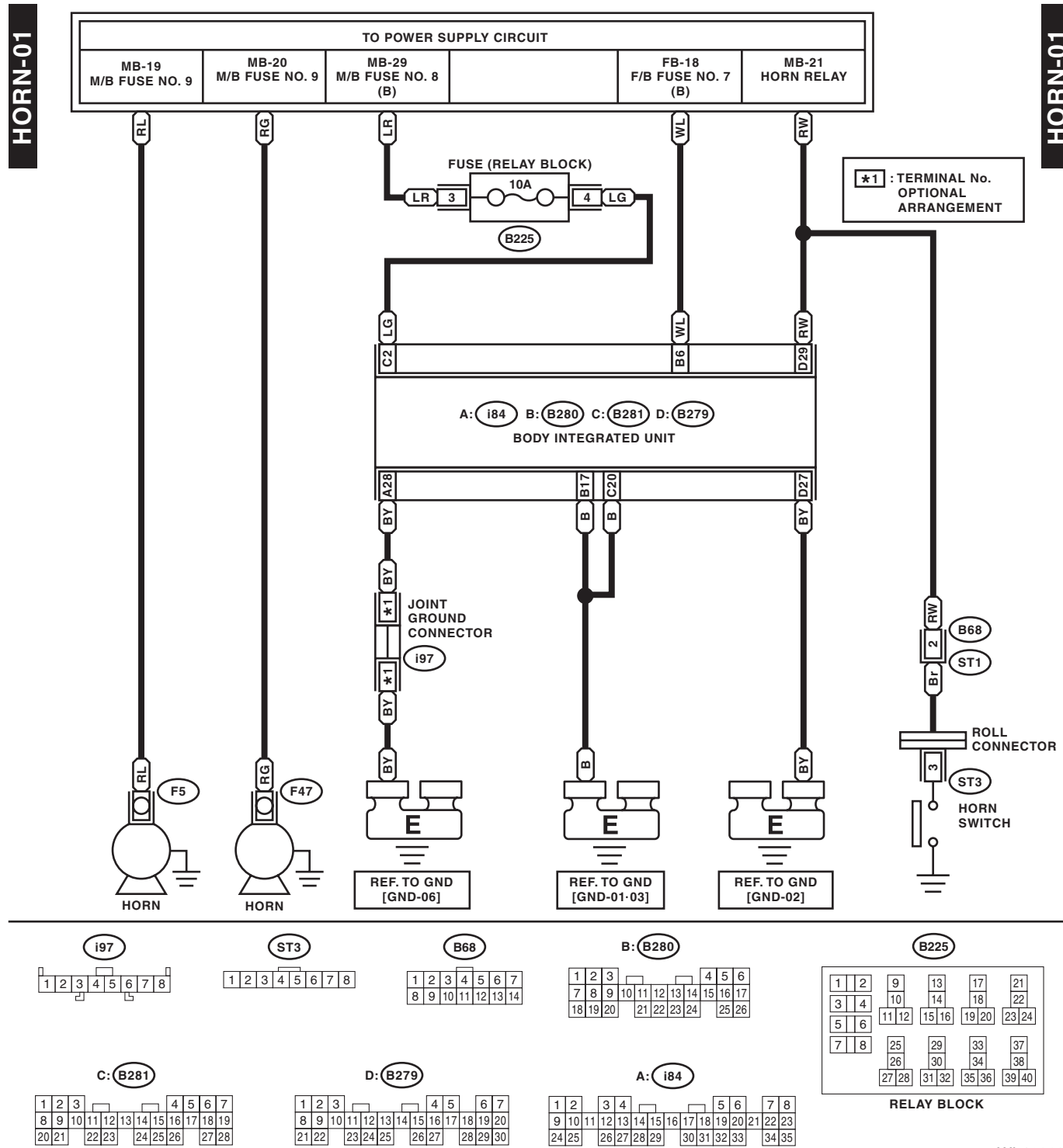

**HORN-01**

WI-16962

Brought to you by  
NOT FOR SALE  
Chris Studios

## 35. Power Window System

### A: WIRING DIAGRAM

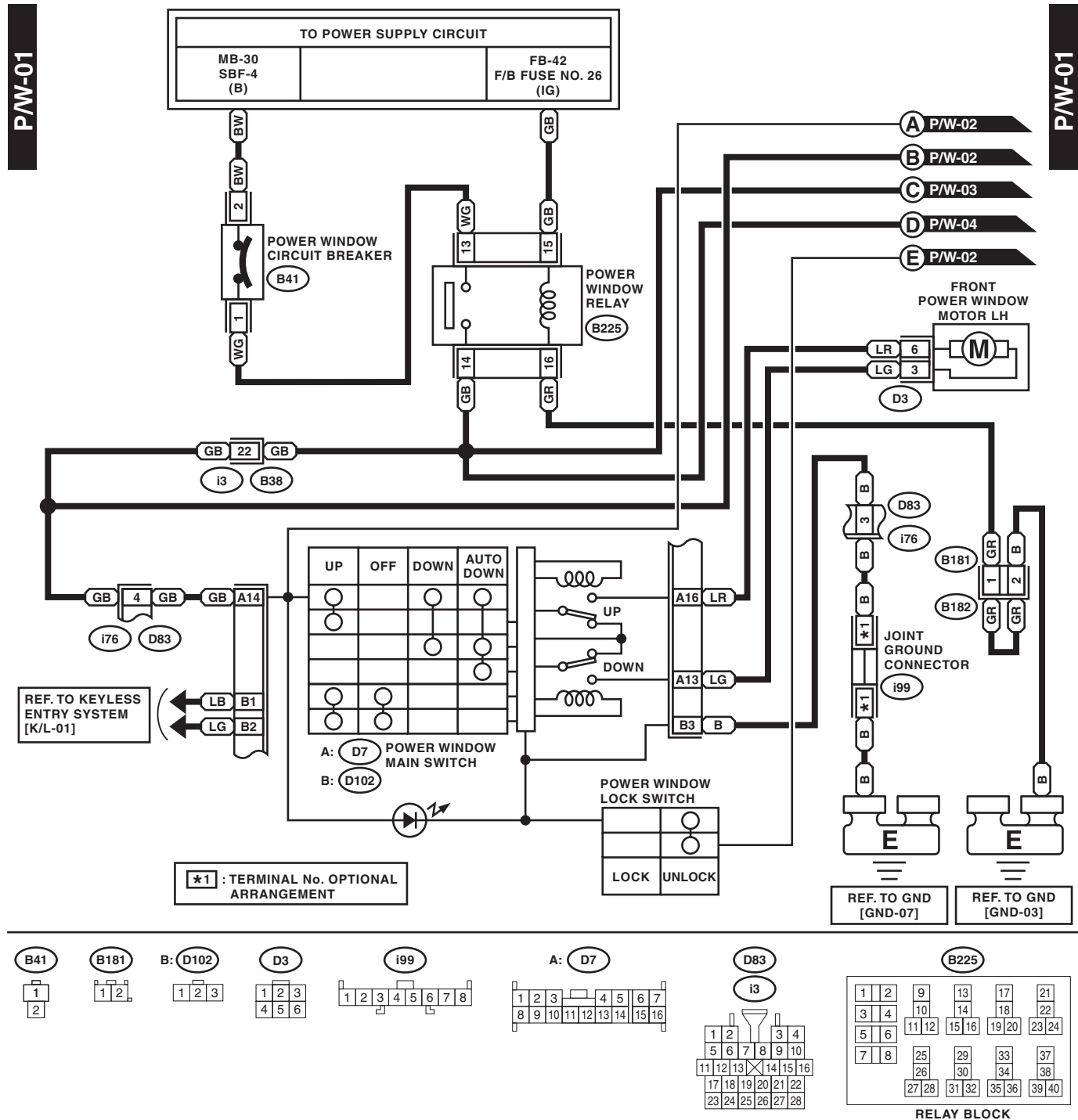

WI-16963

# Power Window System

Brought to you by Eris Studios  
NOT FOR RESALE

## WIRING SYSTEM

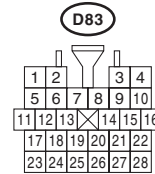
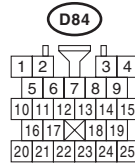
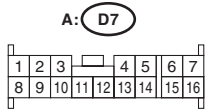
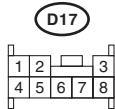
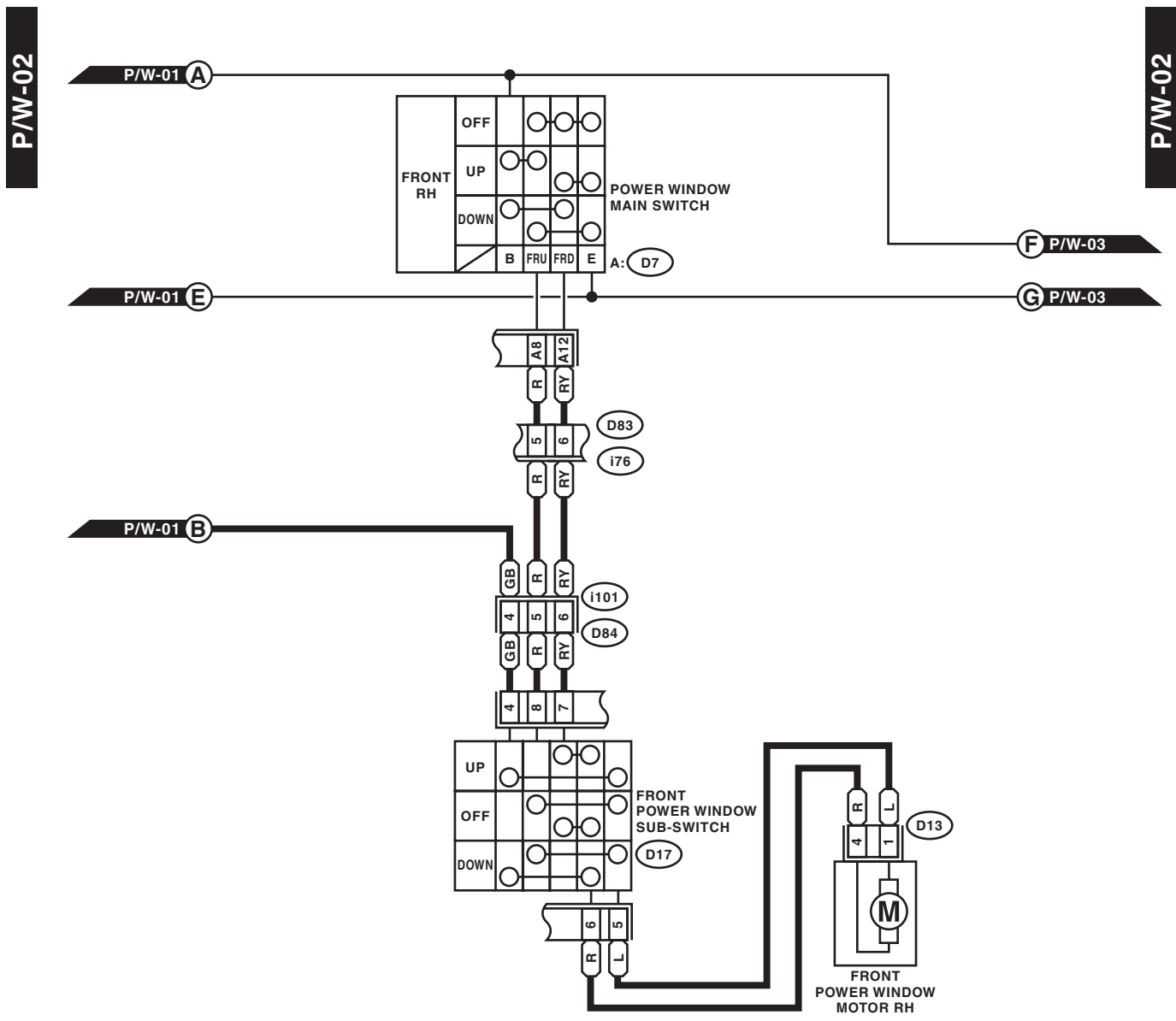

WI-16964

# Power Window System

WIRING SYSTEM

Brought to you by *Chris Studios*  
 NOT FOR SALE

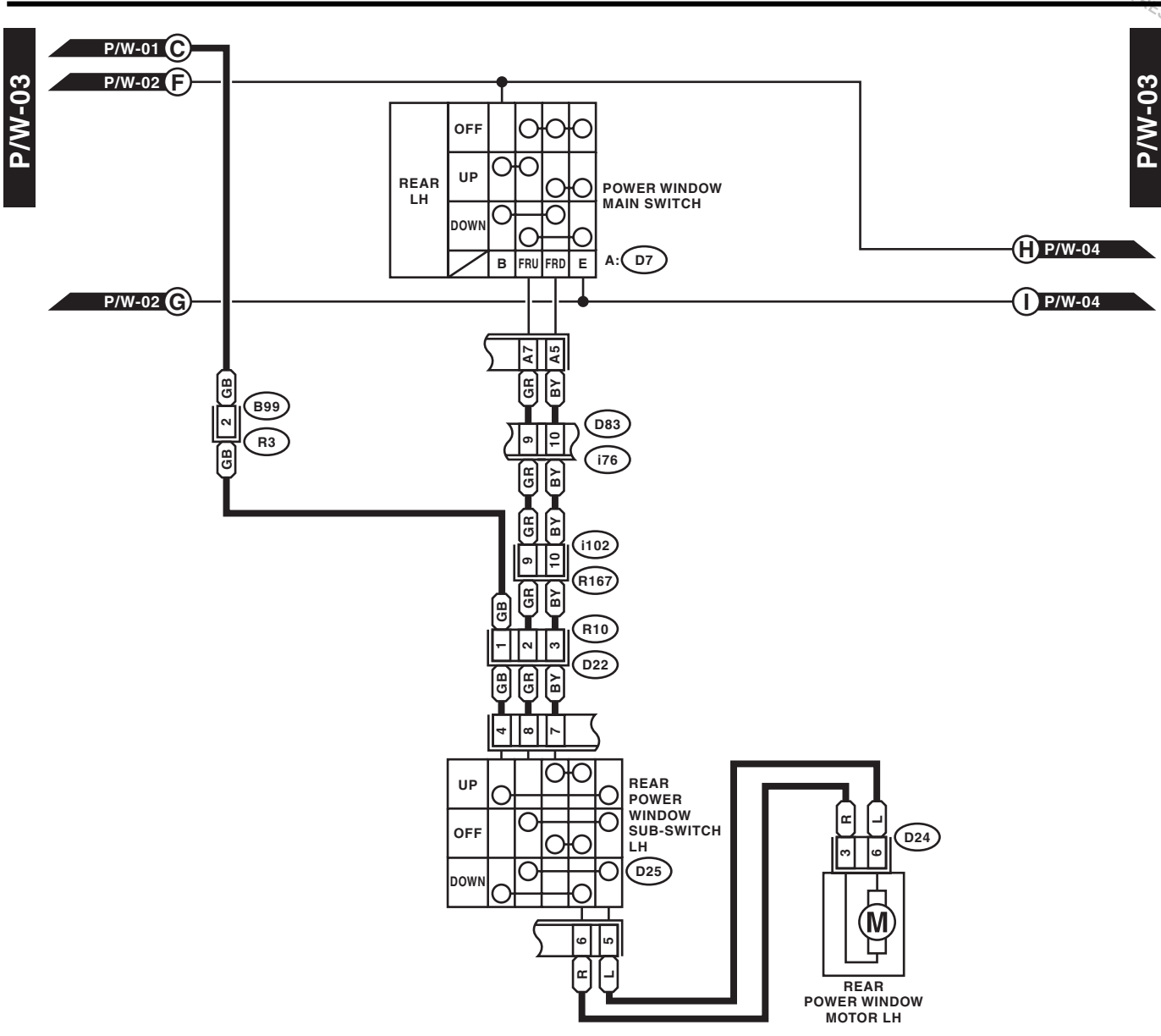

D24



D25

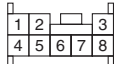

R10

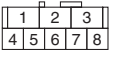

B99

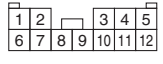

A: D7

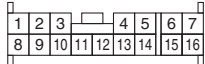

i102

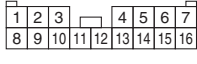

D83

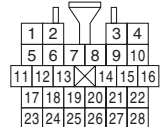

WI-16965

# Power Window System

Brought to you by Eris Studios  
NOT FOR RESALE

## WIRING SYSTEM

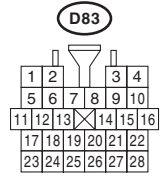
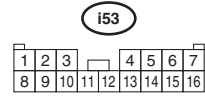
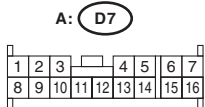
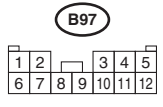
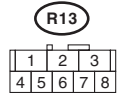
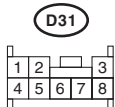
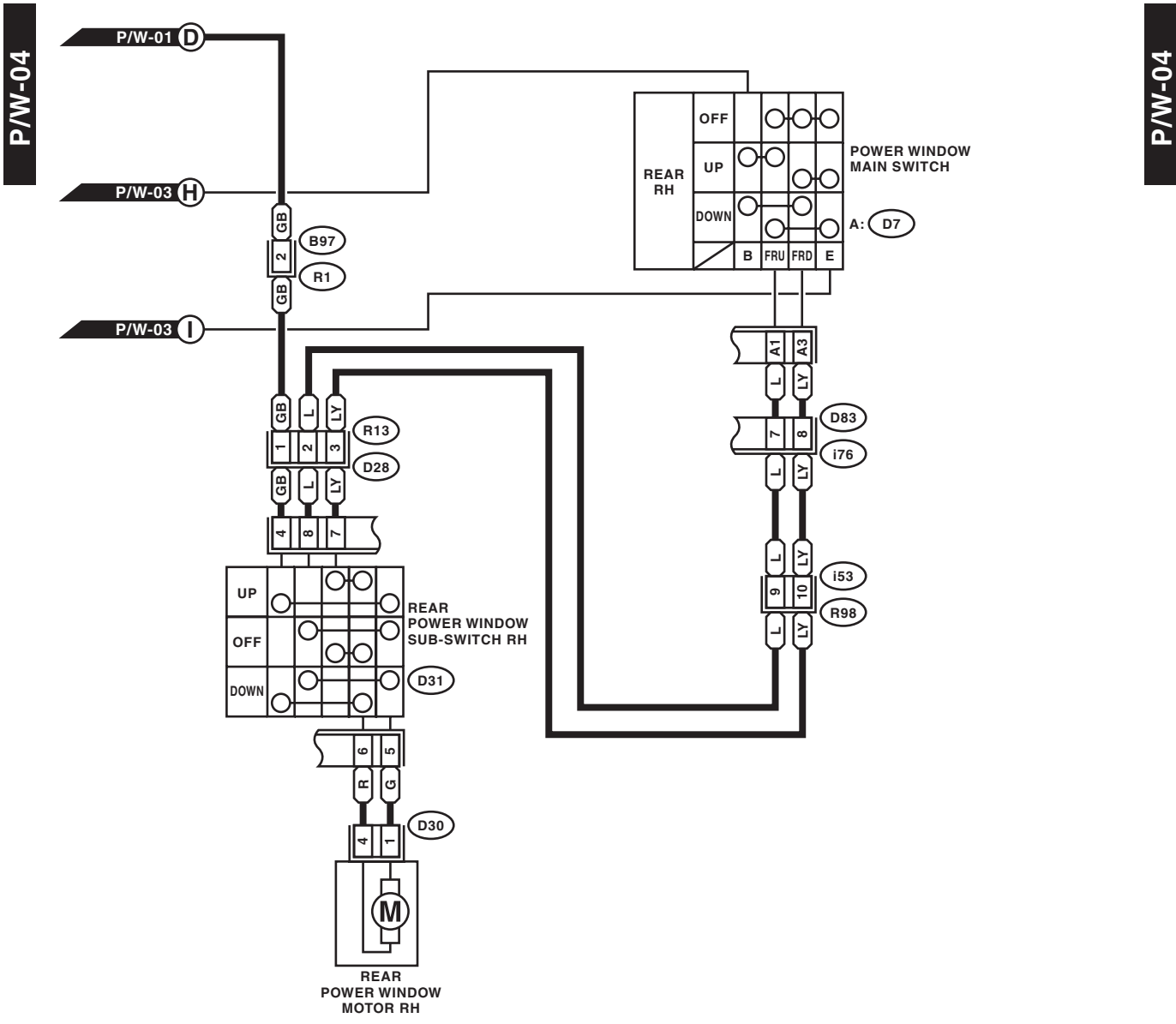

WI-16966

Brought to you by *Chris Studios*  
NOT FOR SALE

## 36. Remote Control Mirror System

### A: WIRING DIAGRAM

R/M-01

R/M-01

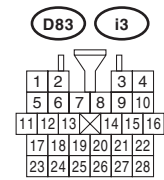
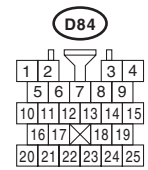
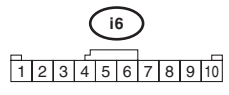
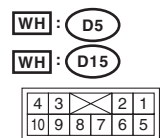
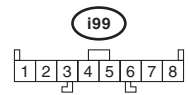
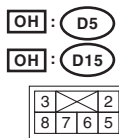
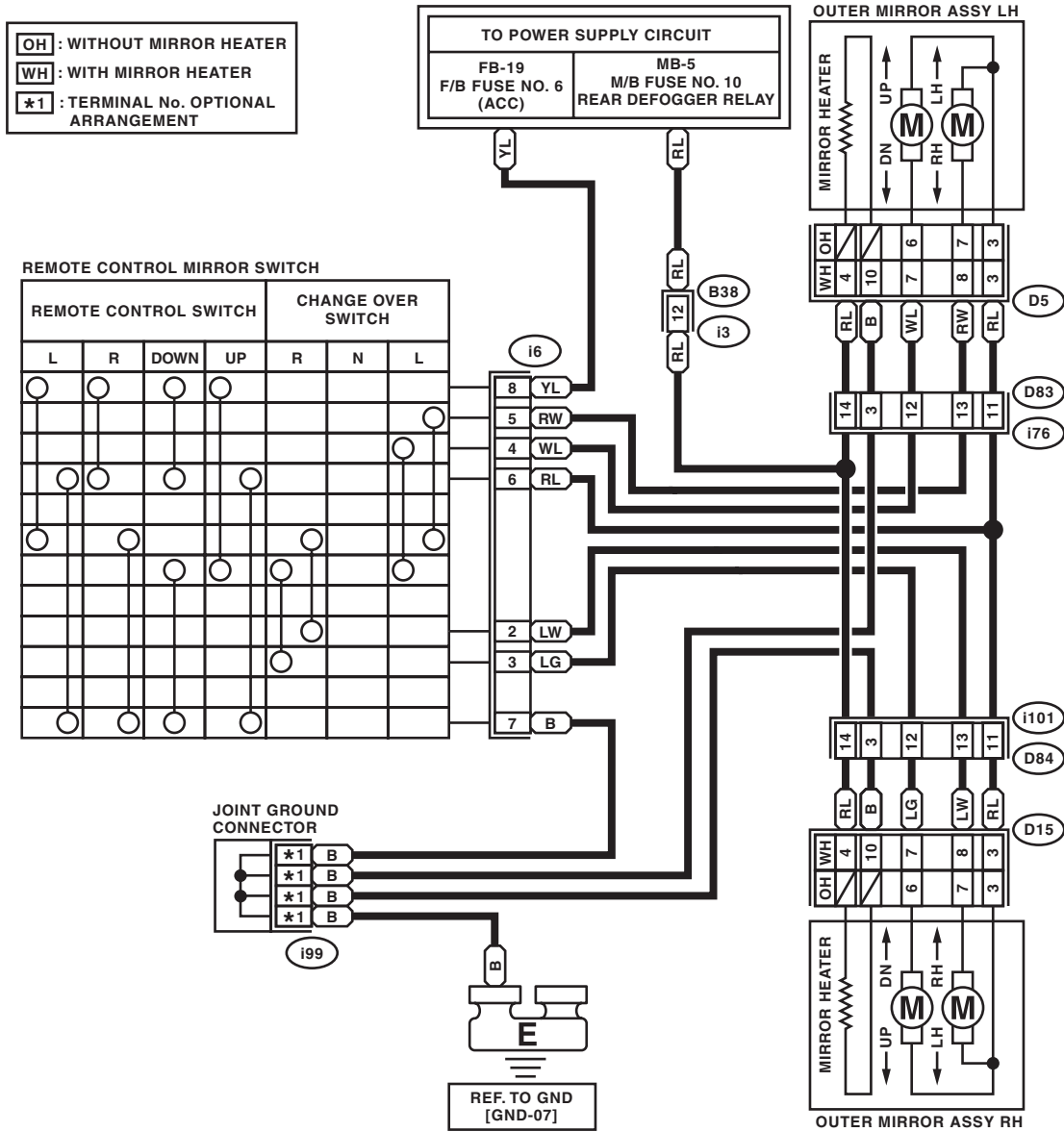

# Rear Defogger System

WIRING SYSTEM

Brought to you by Eris Studios  
NOT FOR RESALE

## 37.Rear Defogger System

### A: WIRING DIAGRAM

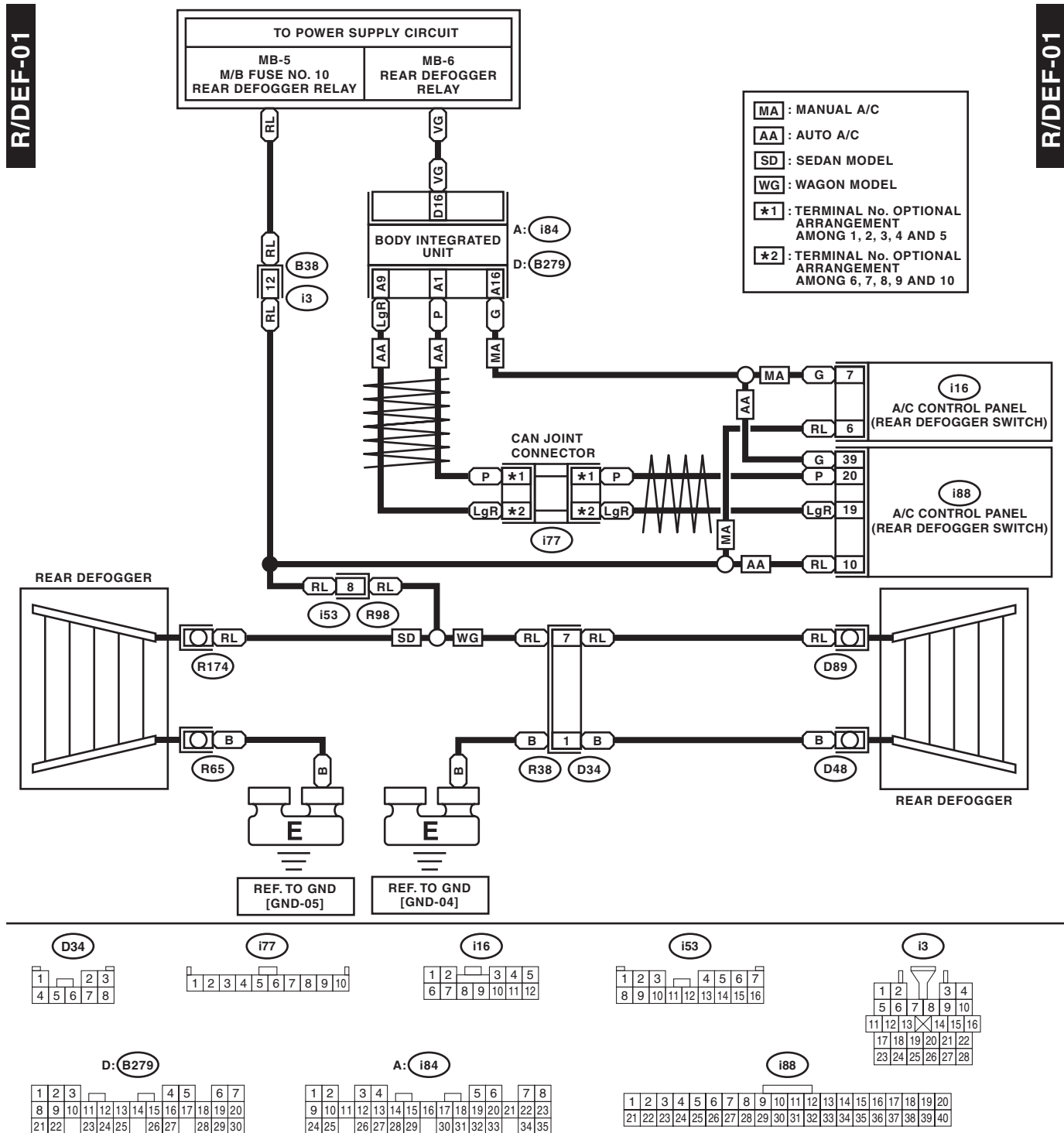

WI-16968



### 38. Combination Meter System

#### A: WIRING DIAGRAM

##### 1. NORMAL METER

C/M(NM)-01

C/M(NM)-01

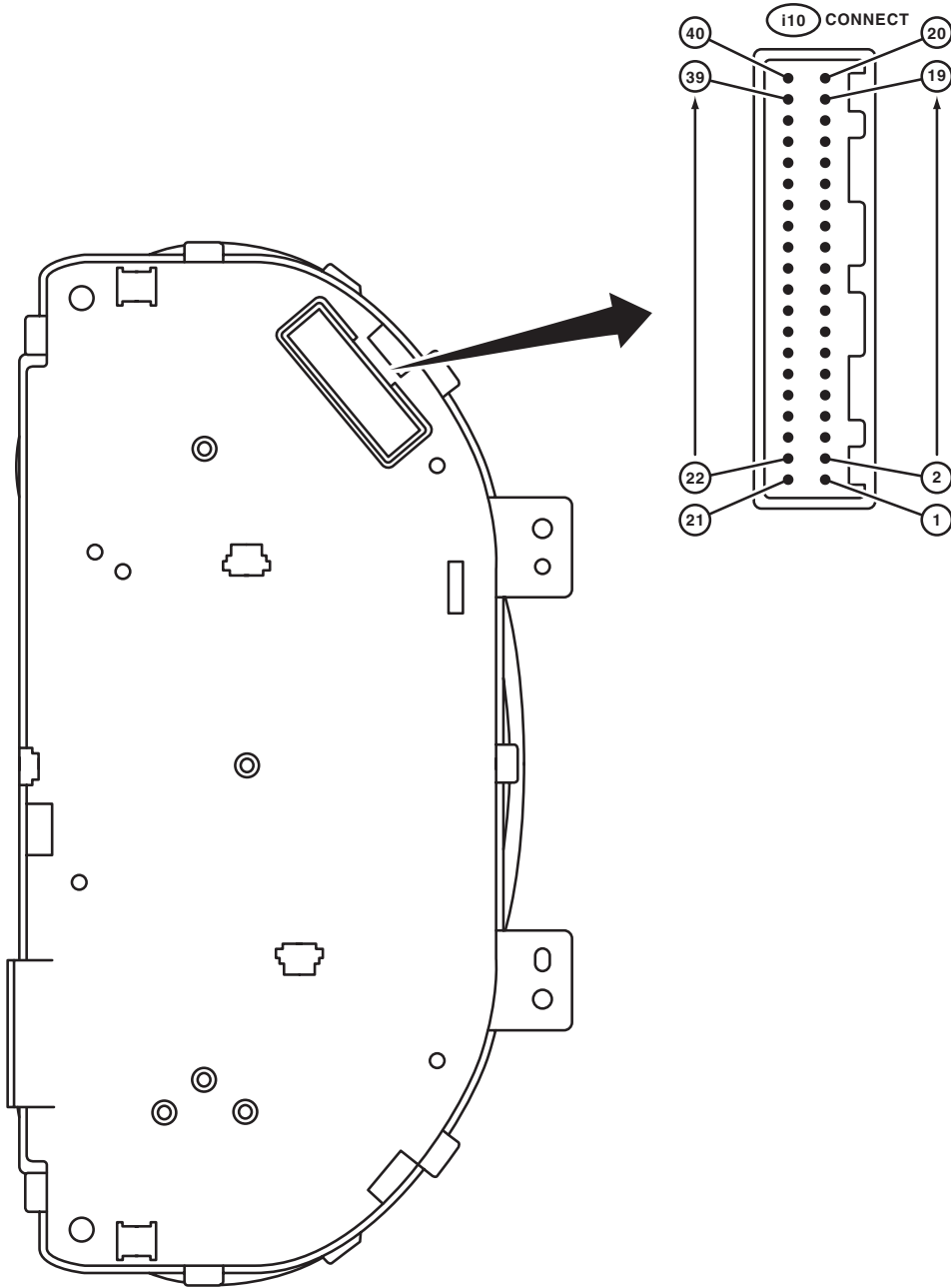

# Combination Meter System

## WIRING SYSTEM

Brought to you by Eris Studios  
NOT FOR RESALE

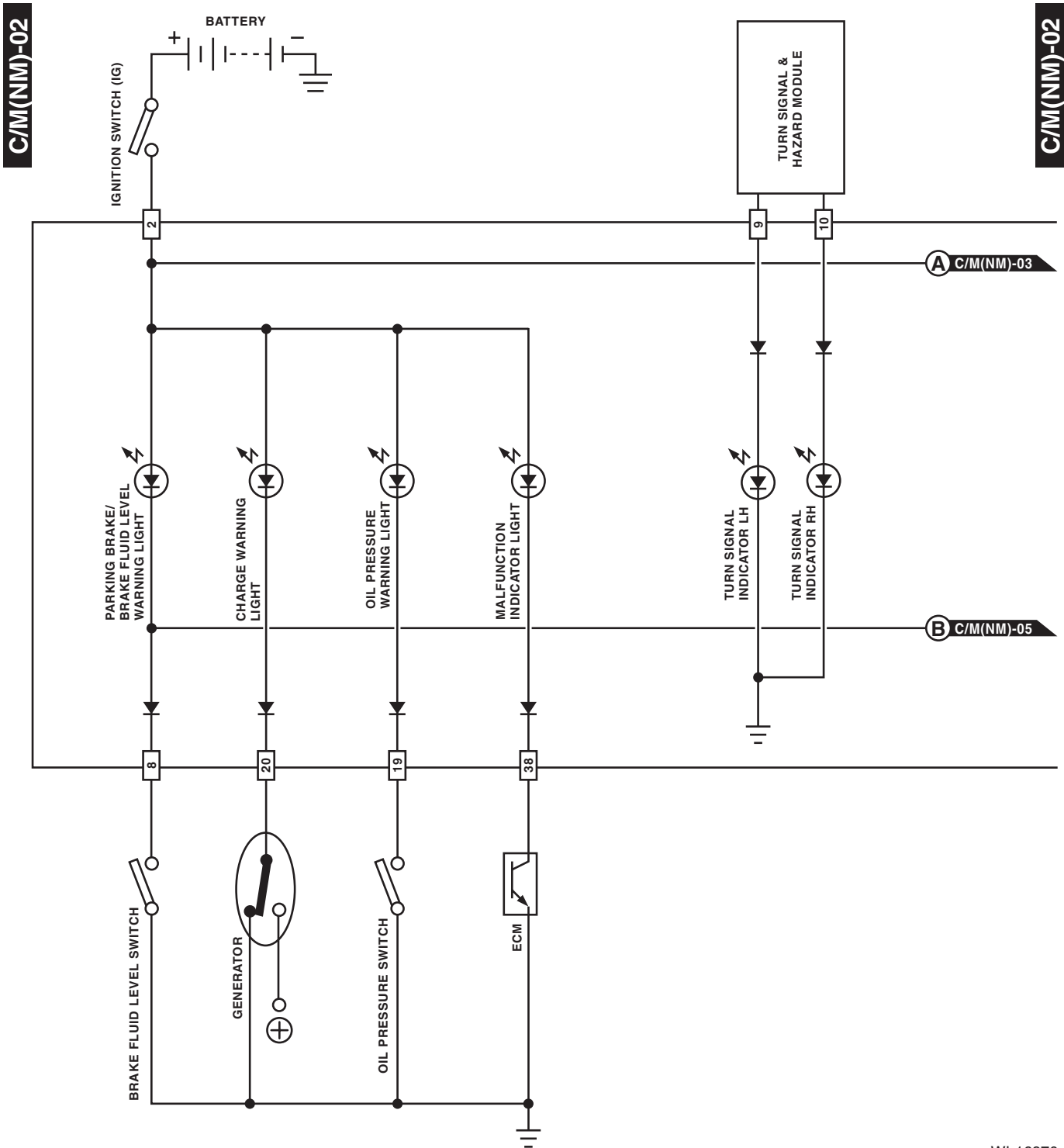

WI-16970

# Combination Meter System

WIRING SYSTEM

Brought to you by  
NOVA Engineering Studios  
NOT FOR SALE

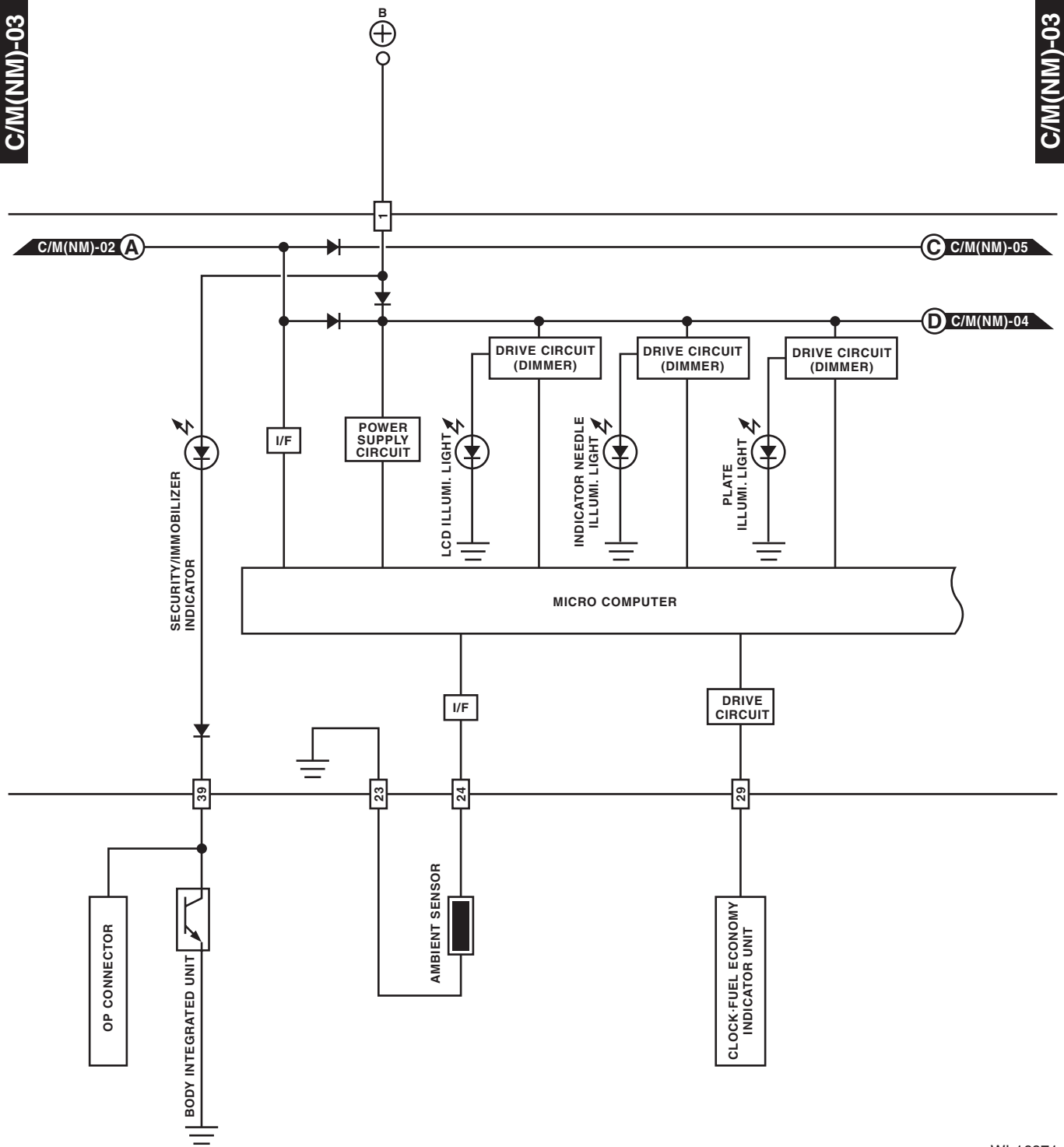

WI-16971

# Combination Meter System

Brought to you by Eris Studios  
NOT FOR RESALE

WIRING SYSTEM

C/M(NM)-04

C/M(NM)-04

ABS	: WITHOUT VDC
VDC	: WITH VDC
WN	: WITH NAVIGATION

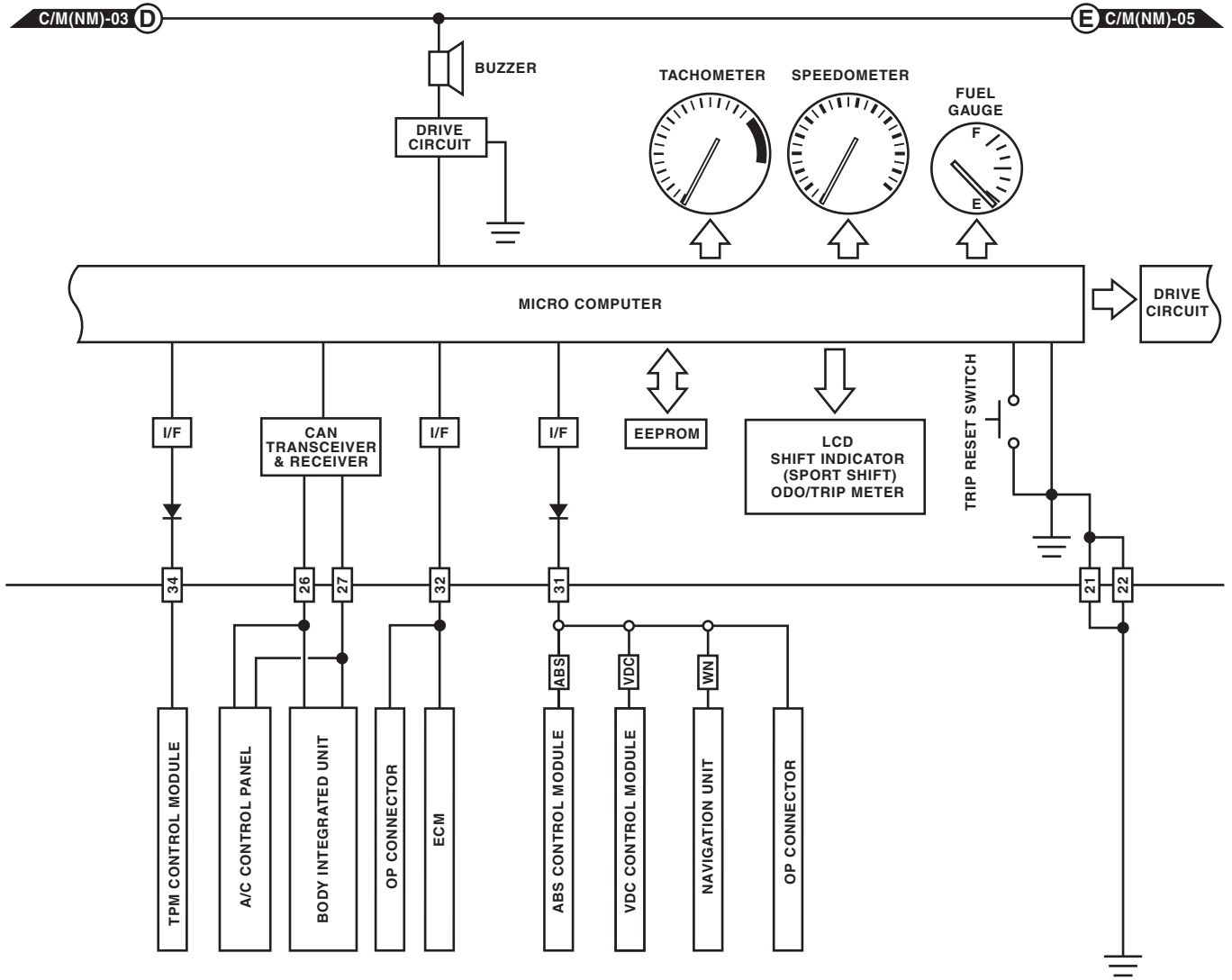

WI-16972

# Combination Meter System

## WIRING SYSTEM

Brought to you by  
NOVUS  
SALES Studios

C/M(NM)-05

C/M(NM)-05

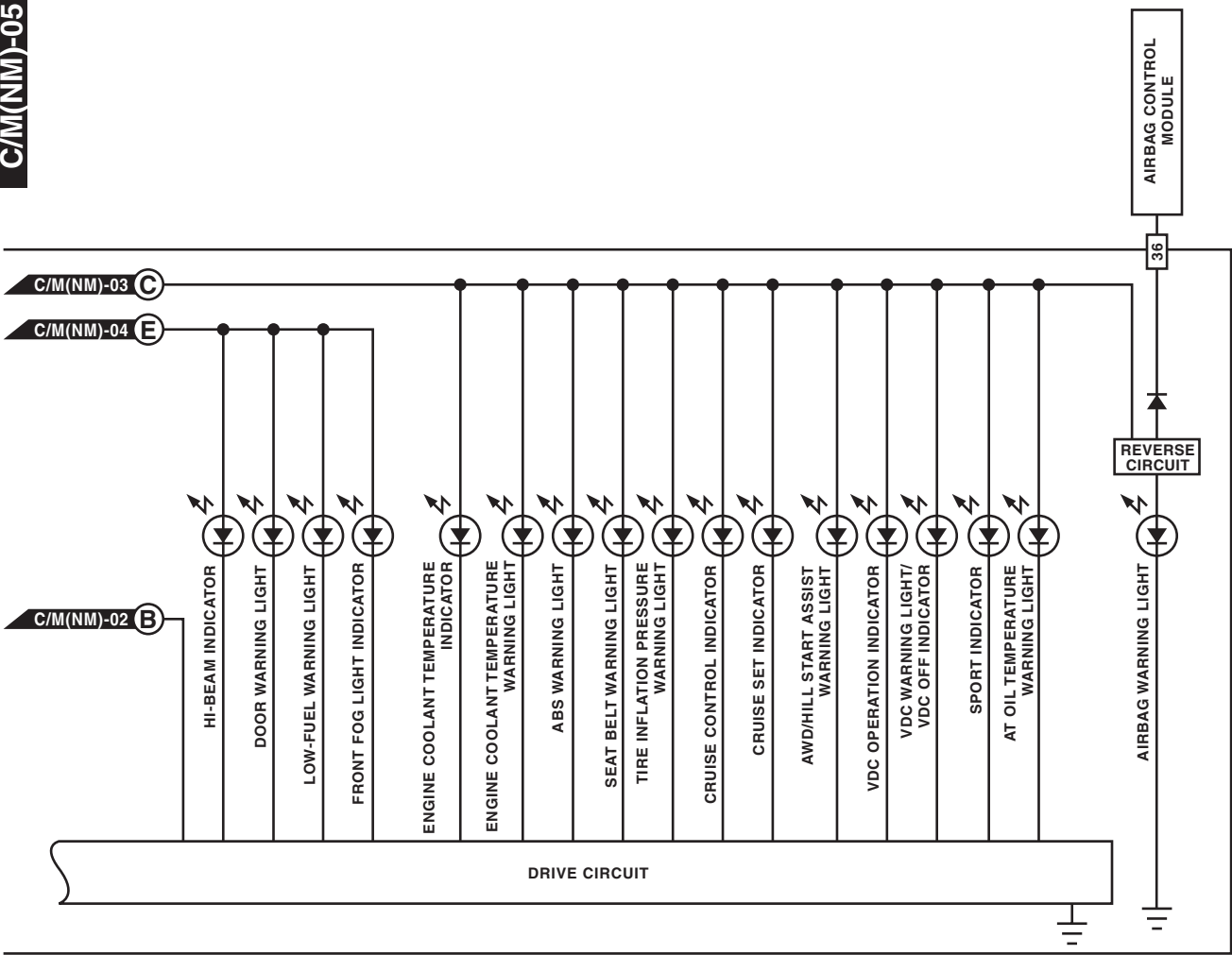

WI-17021

# Combination Meter System

WIRING SYSTEM

Brought to you by Eris Studios  
NOT FOR RESALE

## 2. LUMINESCENT METER

C/M(LM)-01

C/M(LM)-01

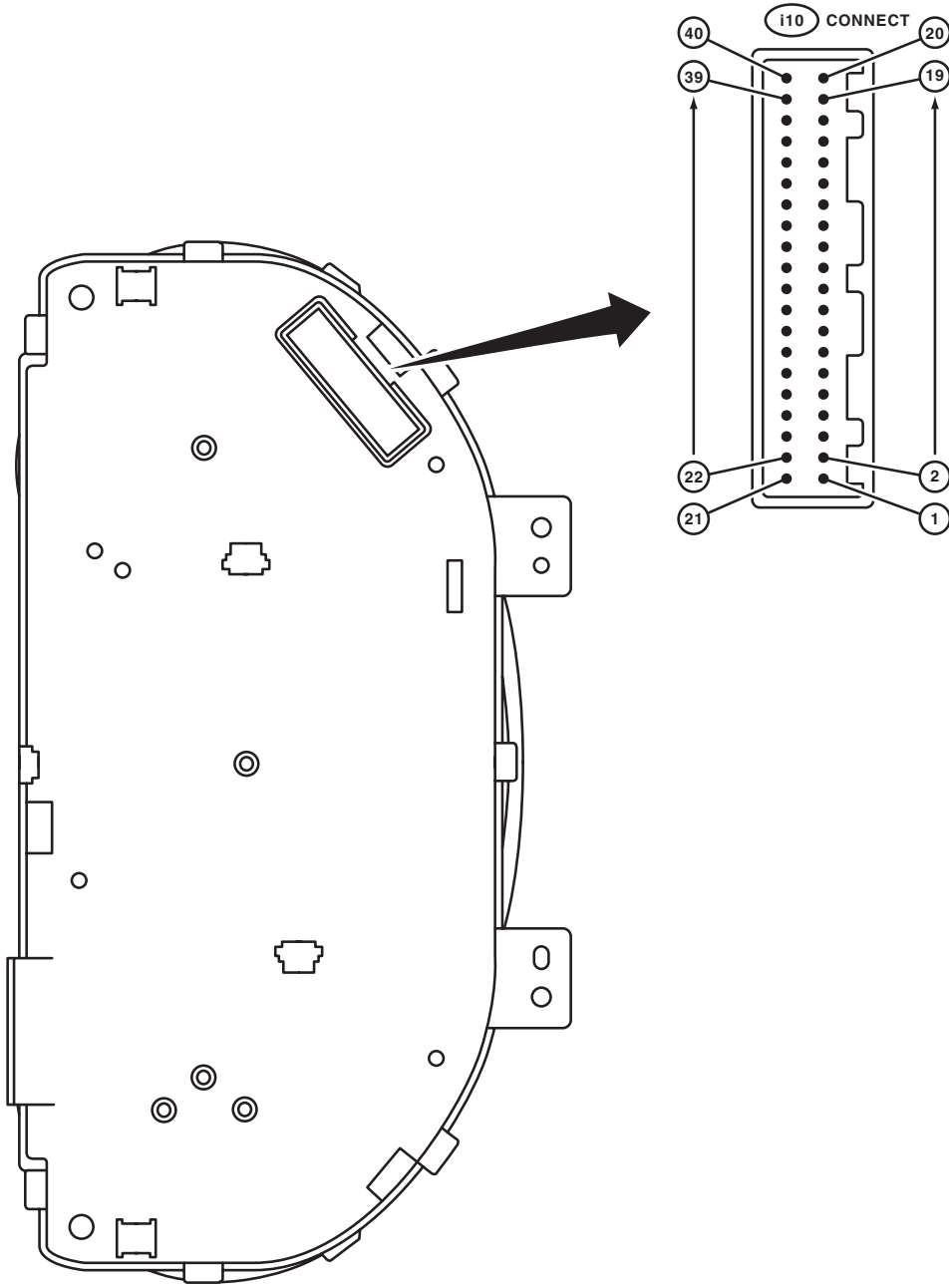

WI-16973

# Combination Meter System

## WIRING SYSTEM

Brought to you by *Chris Studios*  
NOT FOR SALE

C/M(LM)-02

C/M(LM)-02

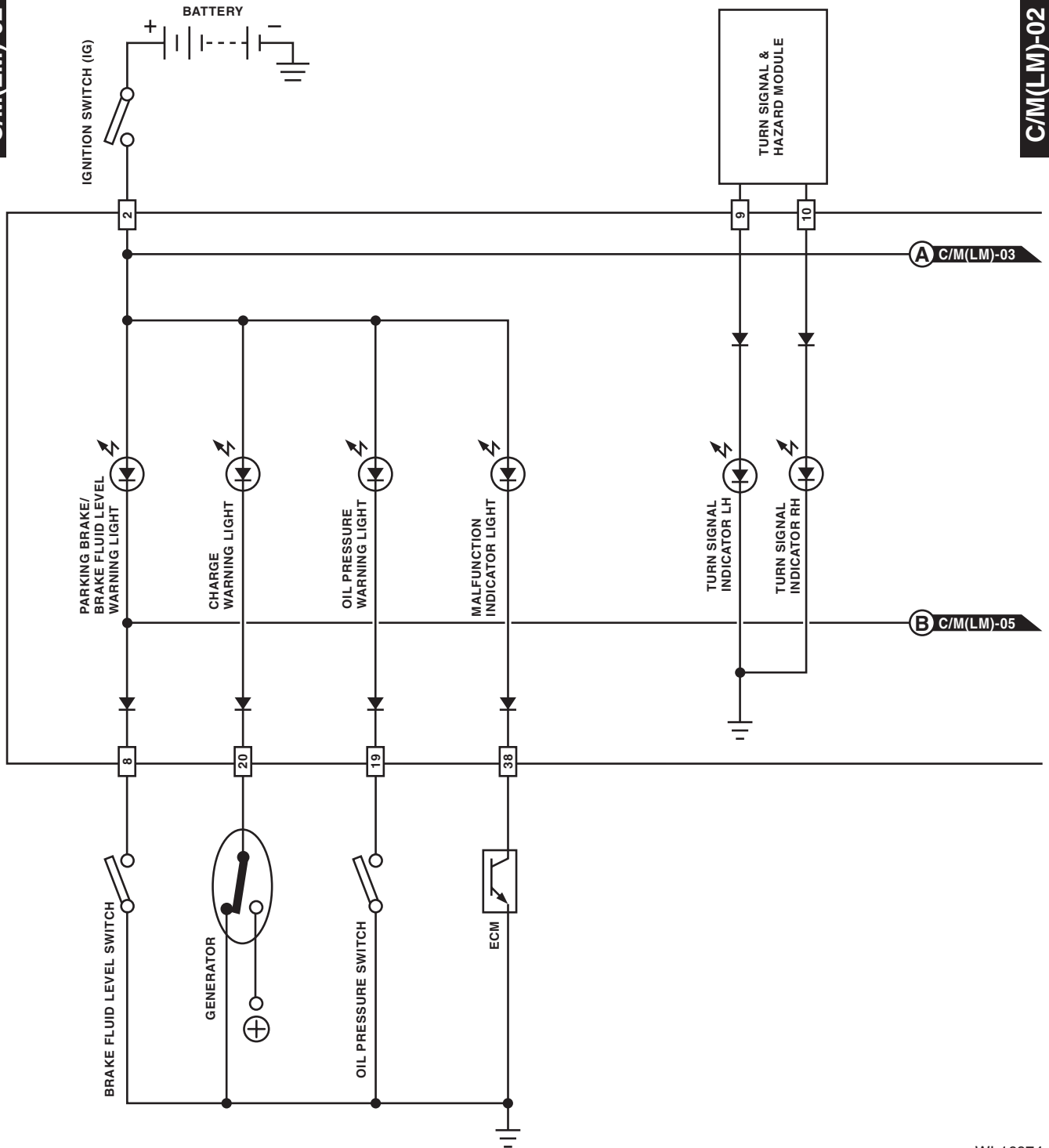

WI-16974

# Combination Meter System

Brought to you by Eris Studios  
NOT FOR RESALE

WIRING SYSTEM

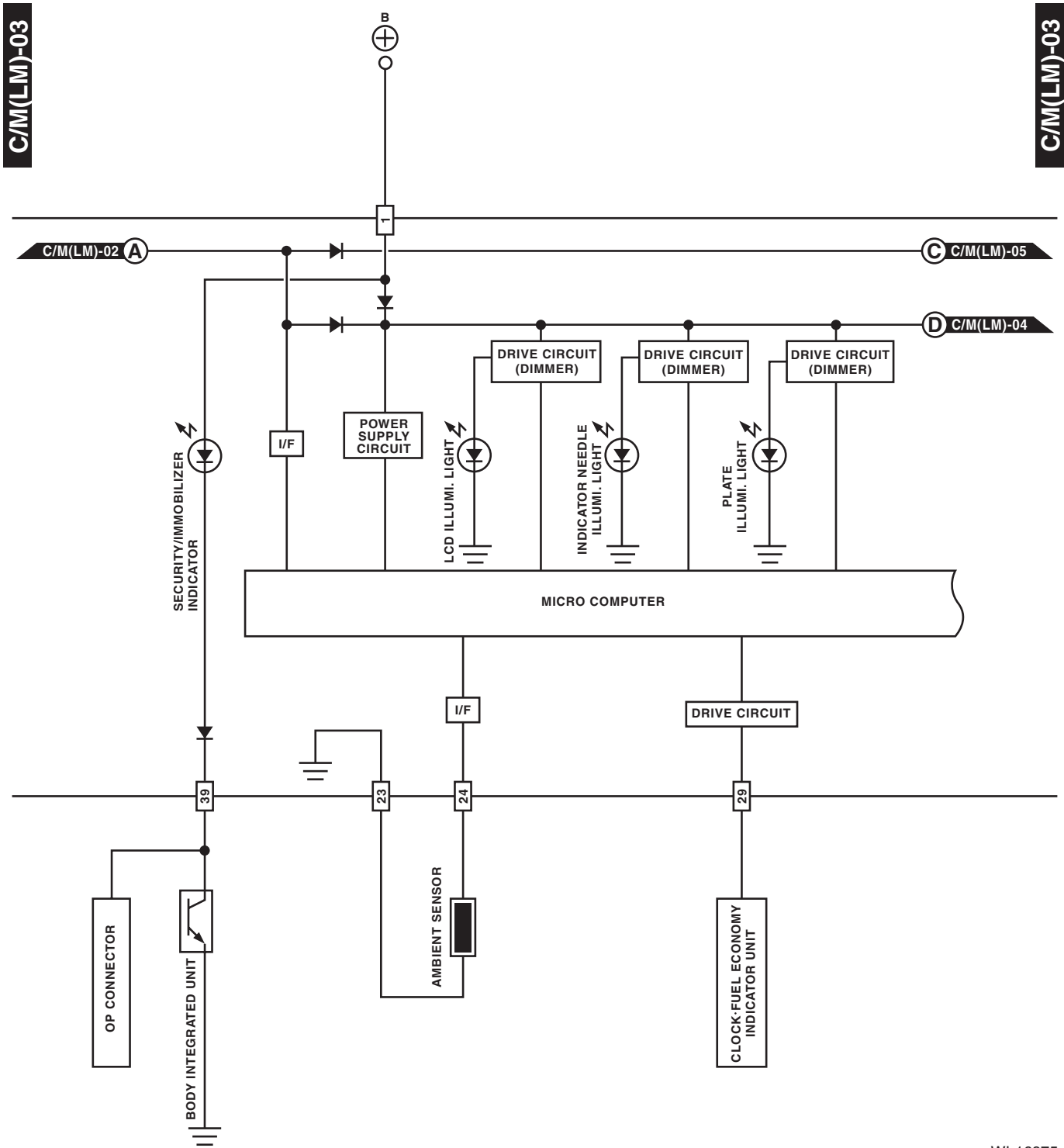

C/M(LM)-03

C/M(LM)-03

WI-16975



# Combination Meter System

WIRING SYSTEM

Brought to you by *Meris Studios*  
 NOT FOR SALE

C/M(LM)-04

C/M(LM)-04

ABS : WITHOUT VDC  
 VDC : WITH VDC  
 WN : WITH NAVIGATION

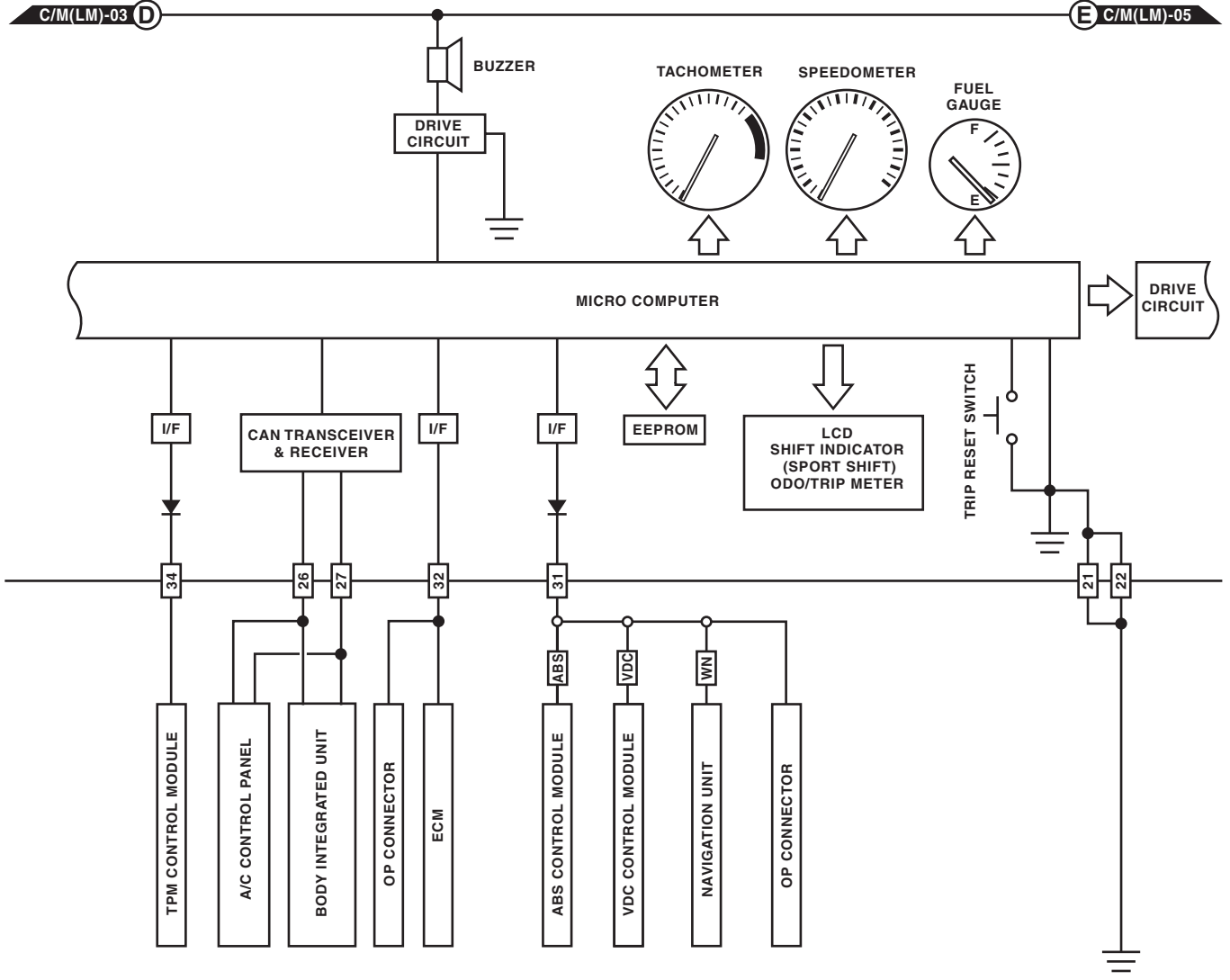

WI-16976

# Combination Meter System

WIRING SYSTEM

Brought to you by Eris Studios  
NOT FOR RESALE

C/M(LM)-05

C/M(LM)-05

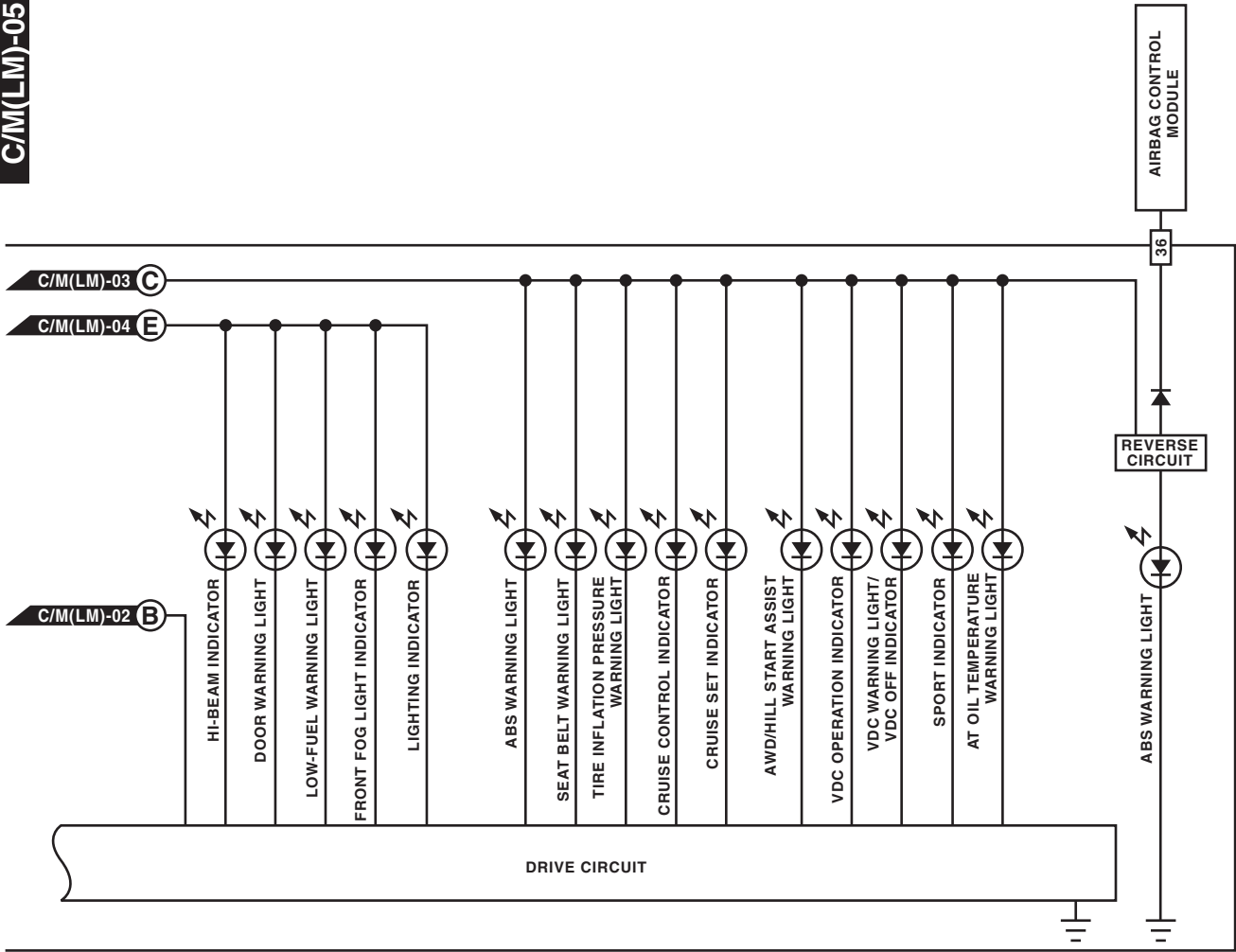

WI-17022

## 39.Speedometer System

### A: WIRING DIAGRAM

**SP-01**

**SP-01**

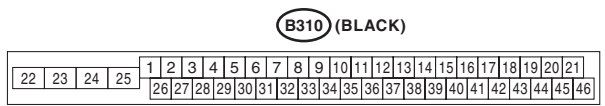
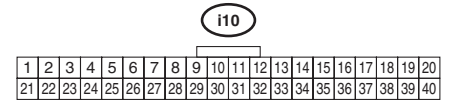
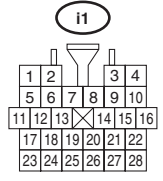
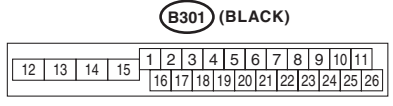
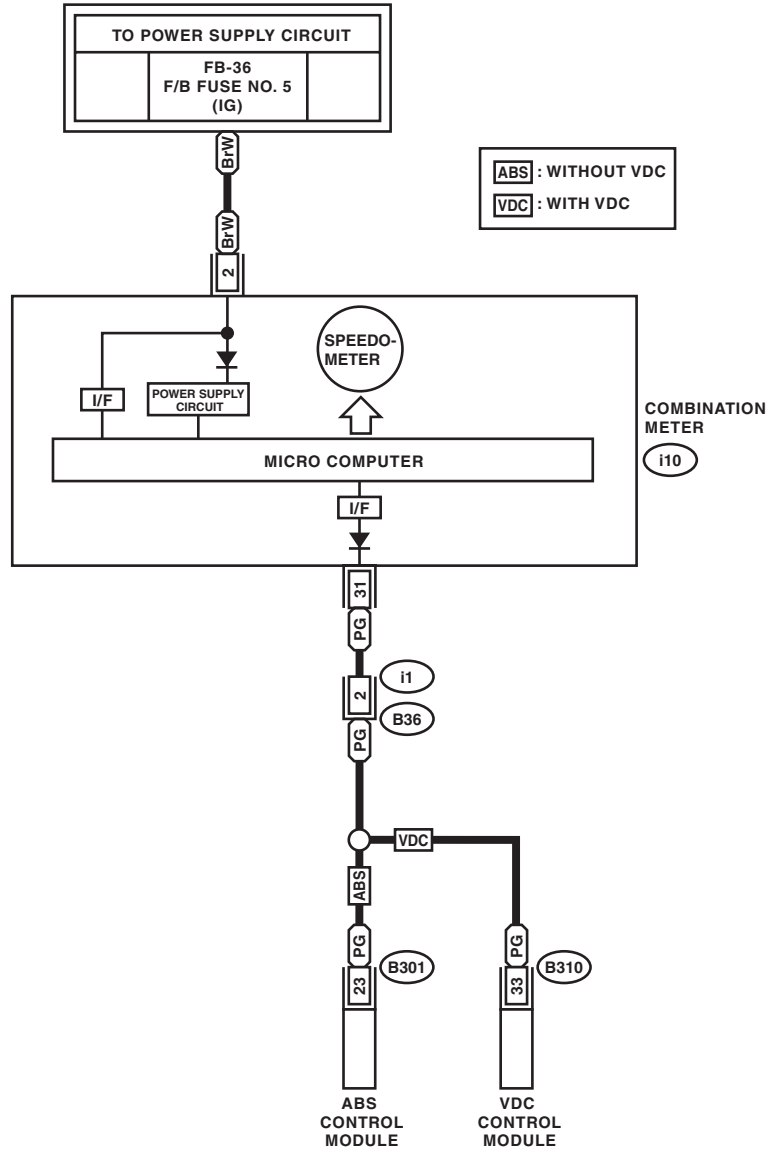



Brought to you by Chris Studios  
NOT FOR SALE

## 41. Fuel Gauge System

### A: WIRING DIAGRAM

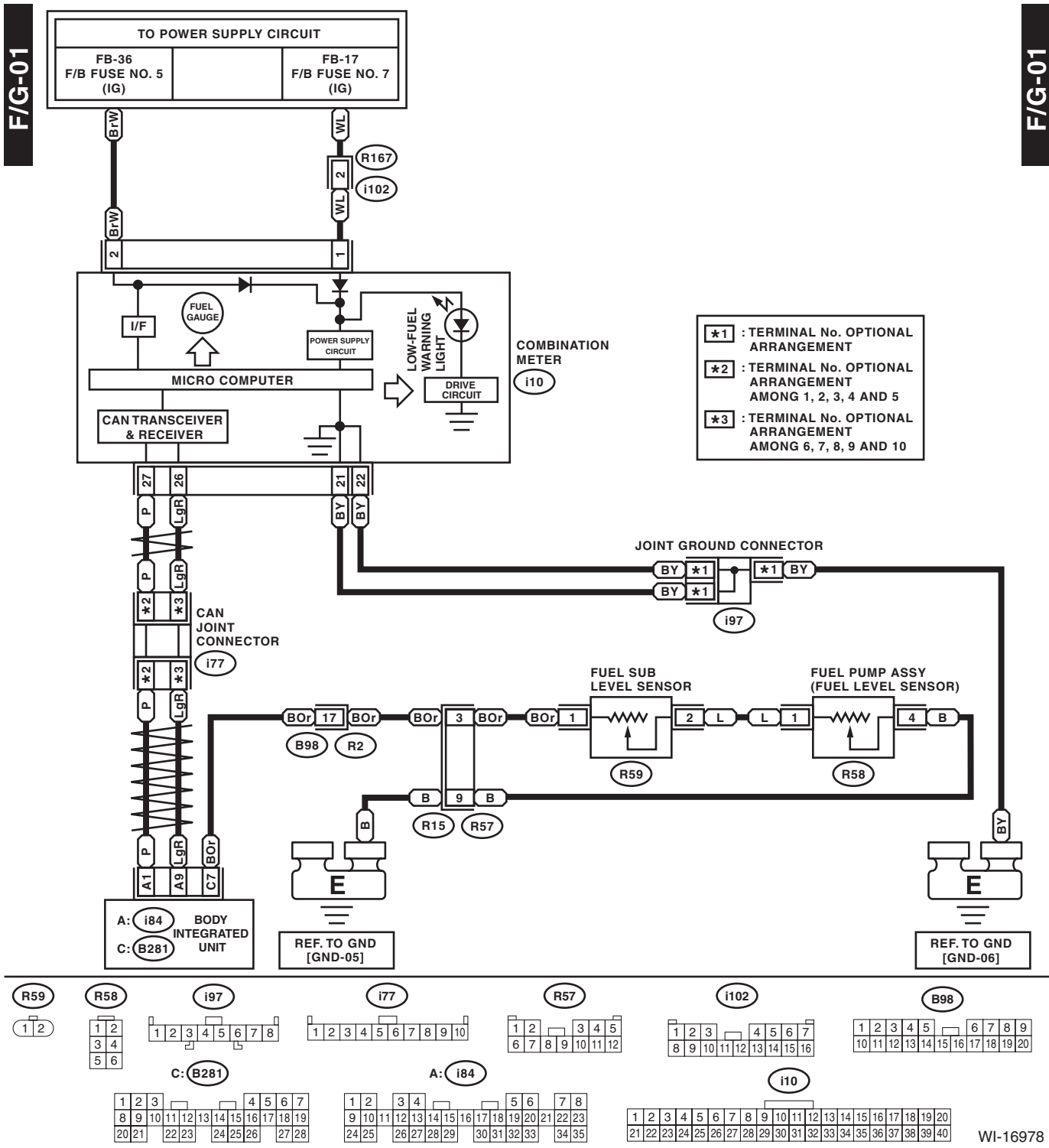

WI-16978

# Coolant Temperature System

Brought to you by Eris Studios  
NOT FOR SALE

WIRING SYSTEM

## 42. Coolant Temperature System

### A: WIRING DIAGRAM

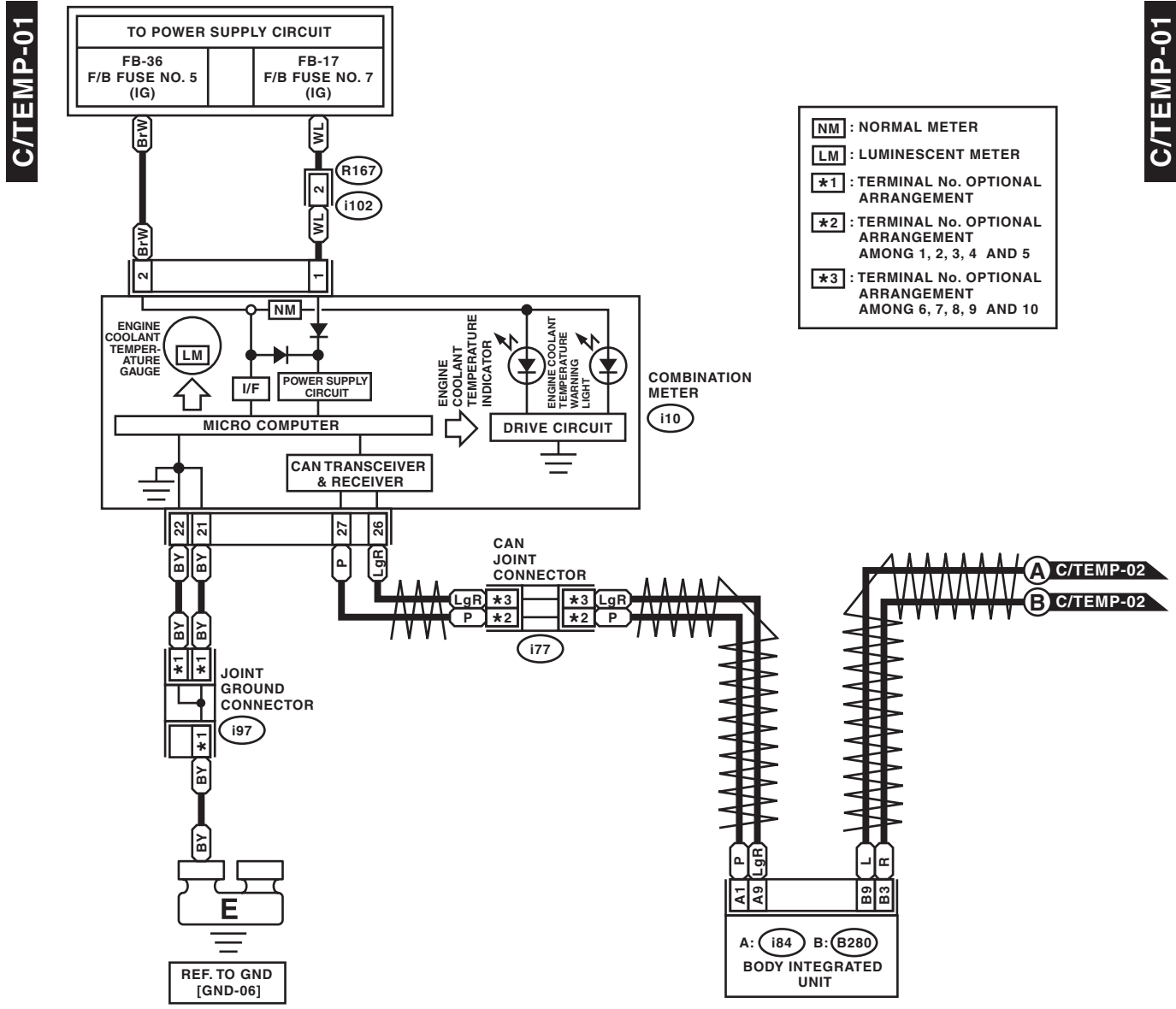

- NM** : NORMAL METER
- LM** : LUMINESCENT METER
- \*1** : TERMINAL No. OPTIONAL ARRANGEMENT AMONG 1, 2, 3, 4 AND 5
- \*2** : TERMINAL No. OPTIONAL ARRANGEMENT AMONG 1, 2, 3, 4 AND 5
- \*3** : TERMINAL No. OPTIONAL ARRANGEMENT AMONG 6, 7, 8, 9 AND 10

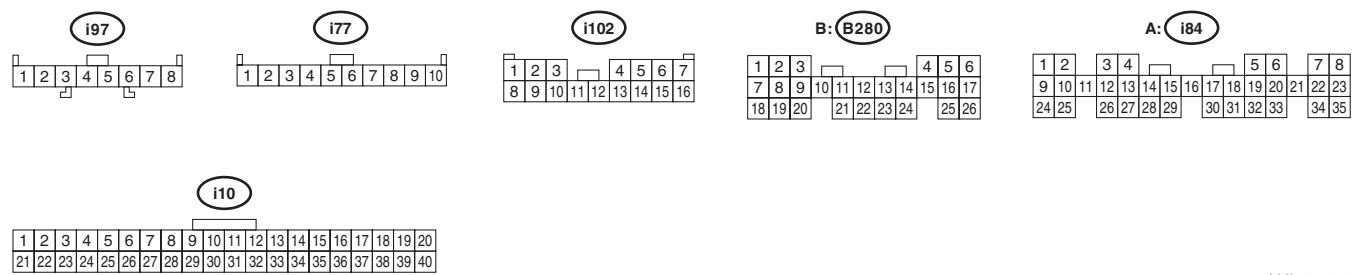

WI-16979

# Coolant Temperature System

WIRING SYSTEM

Brought to you by *Chris Studios*  
NO RESALE

C/TEMP-02

C/TEMP-02

NA : NON-TURBO MODEL  
TB : TURBO MODEL

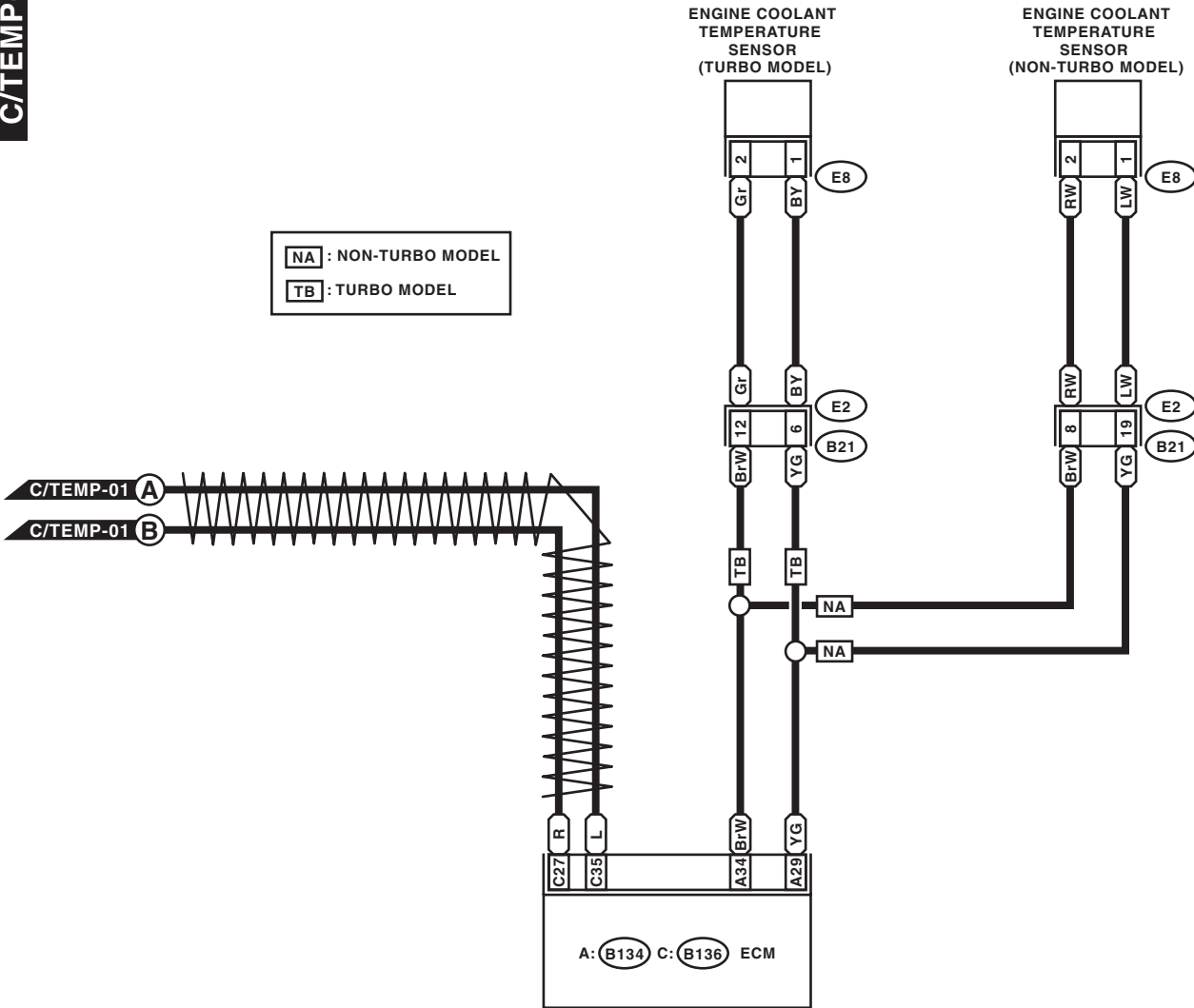

E8 (BLACK)

1	2
---	---

A: B134

1	2	3	4	5	6	7			
8	9	10	11	12	13	14	15	16	17
18	19	20	21	22	23	24	25	26	27
28	29	30	31	32	33	34			

C: B136

1	2	3	4	5	6					
7	8	9	10	11	12	13	14	15	16	
17	18	19	20	21	22	23	24	25	26	27
28	29	30	31	32	33	34	35			

B21

1	2	3	4	5	6	7	8	9	10	11
12	13	14	15	16	17	18	19	20	21	22
23	24	25	26	27	28	29	30	31	32	33
34	35	36	37	38	39	40	41			
42	43	44	45	46	47					
48	49	50	51	52	53	54				

WI-16980

# Oil Pressure Warning Light System

WIRING SYSTEM

Brought to you by Eris Studios  
NOT FOR RESALE

## 43. Oil Pressure Warning Light System

### A: WIRING DIAGRAM

OIL/P-01

OIL/P-01

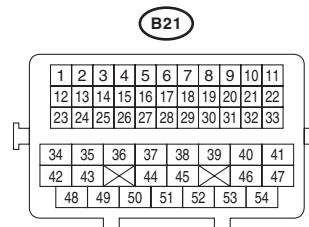
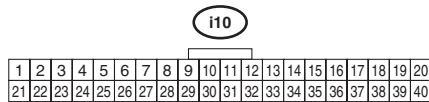
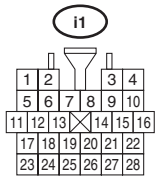
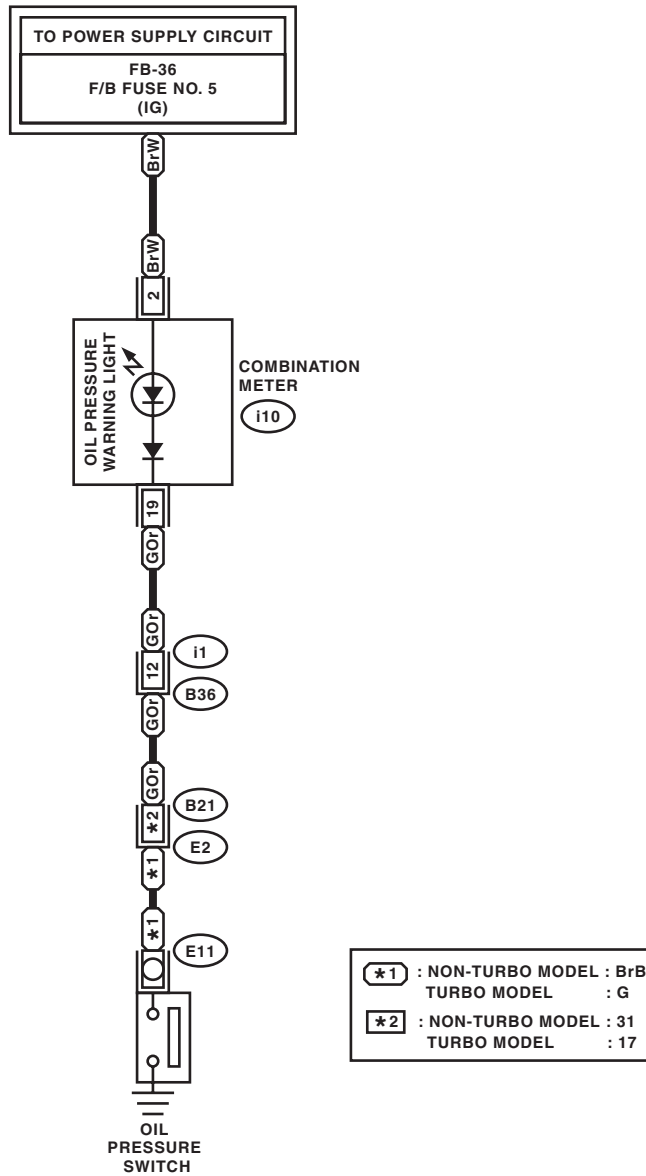

WI-16982



## 44. Parking Brake / Brake Fluid Level Warning Light System

### A: WIRING DIAGRAM

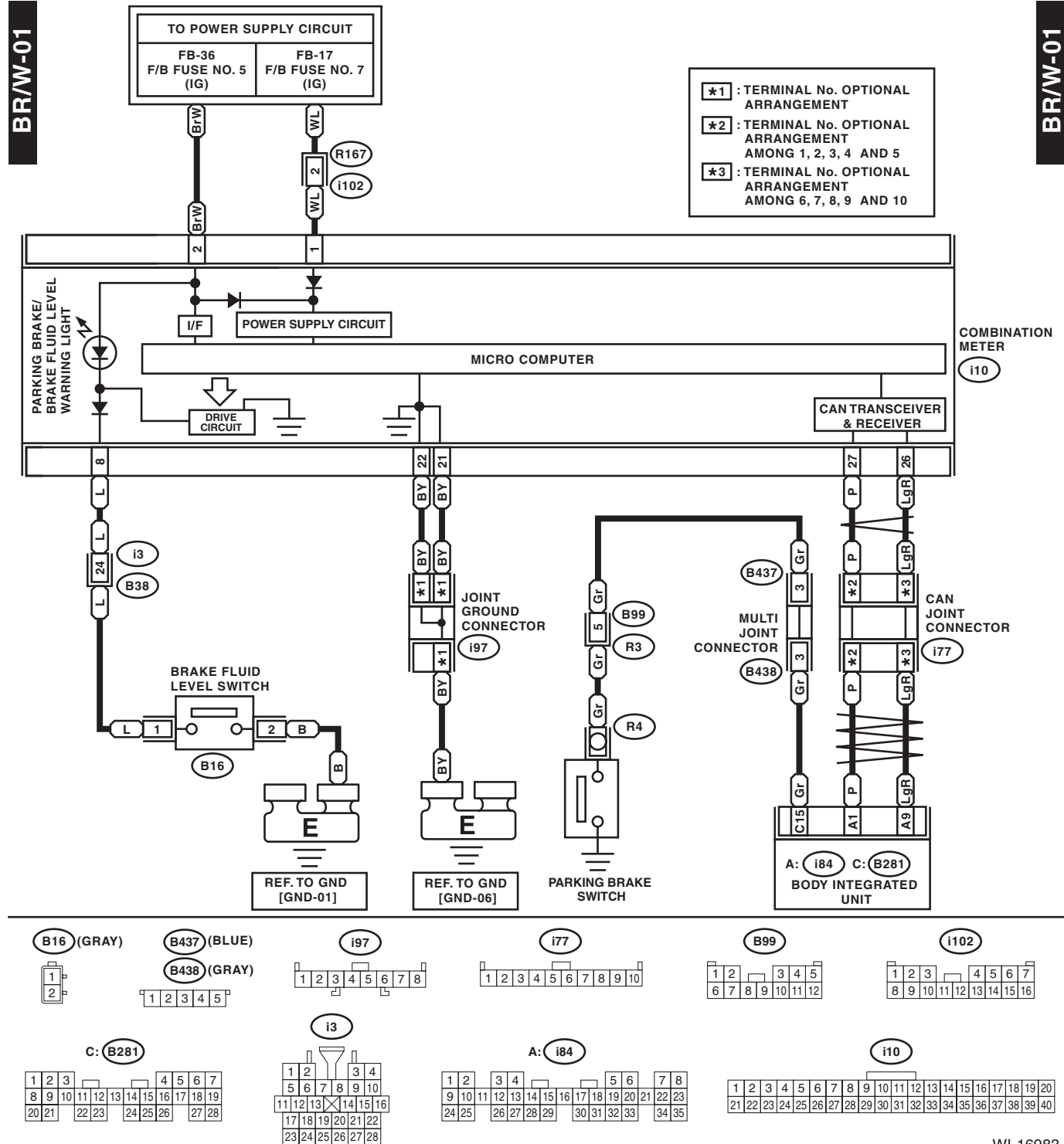

## WIRING SYSTEM

### 45. Security System

#### A: WIRING DIAGRAM

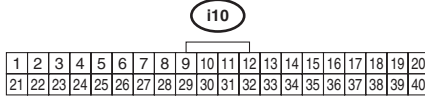
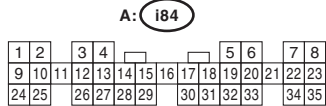
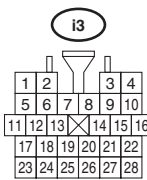
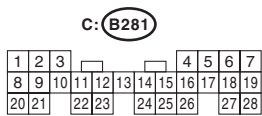
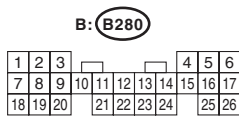
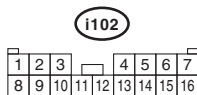
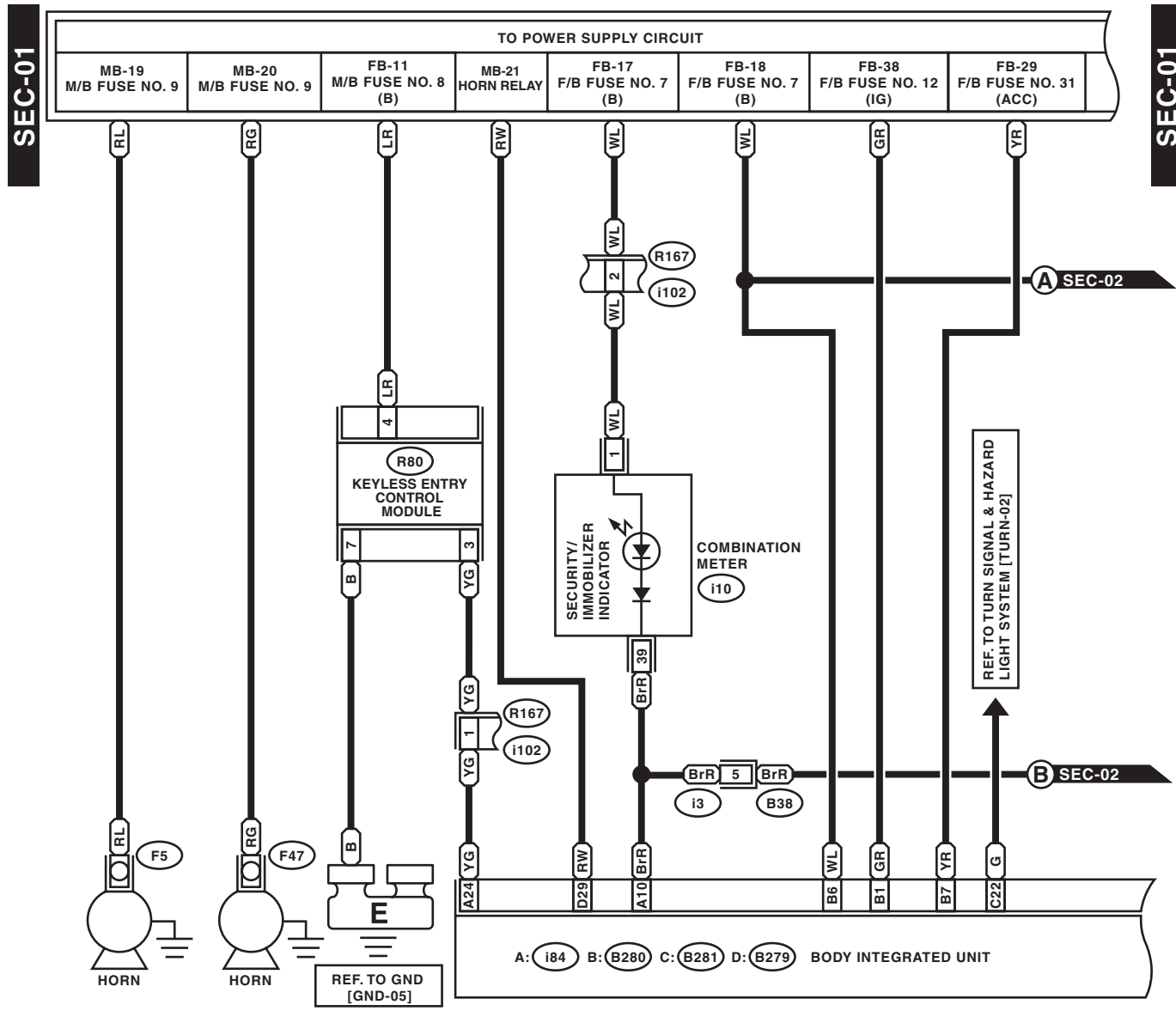

WI-16985

# Security System

## WIRING SYSTEM

Brought to you by *Chris Studios*  
 NOT FOR SALE

SEC-02

SEC-02

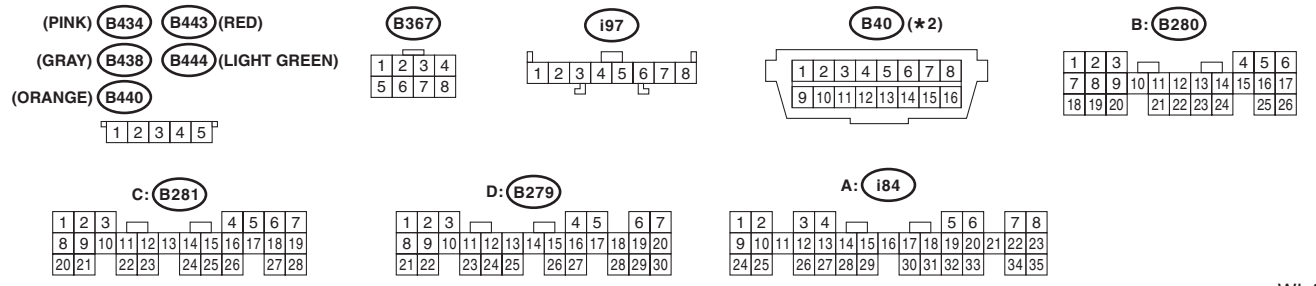
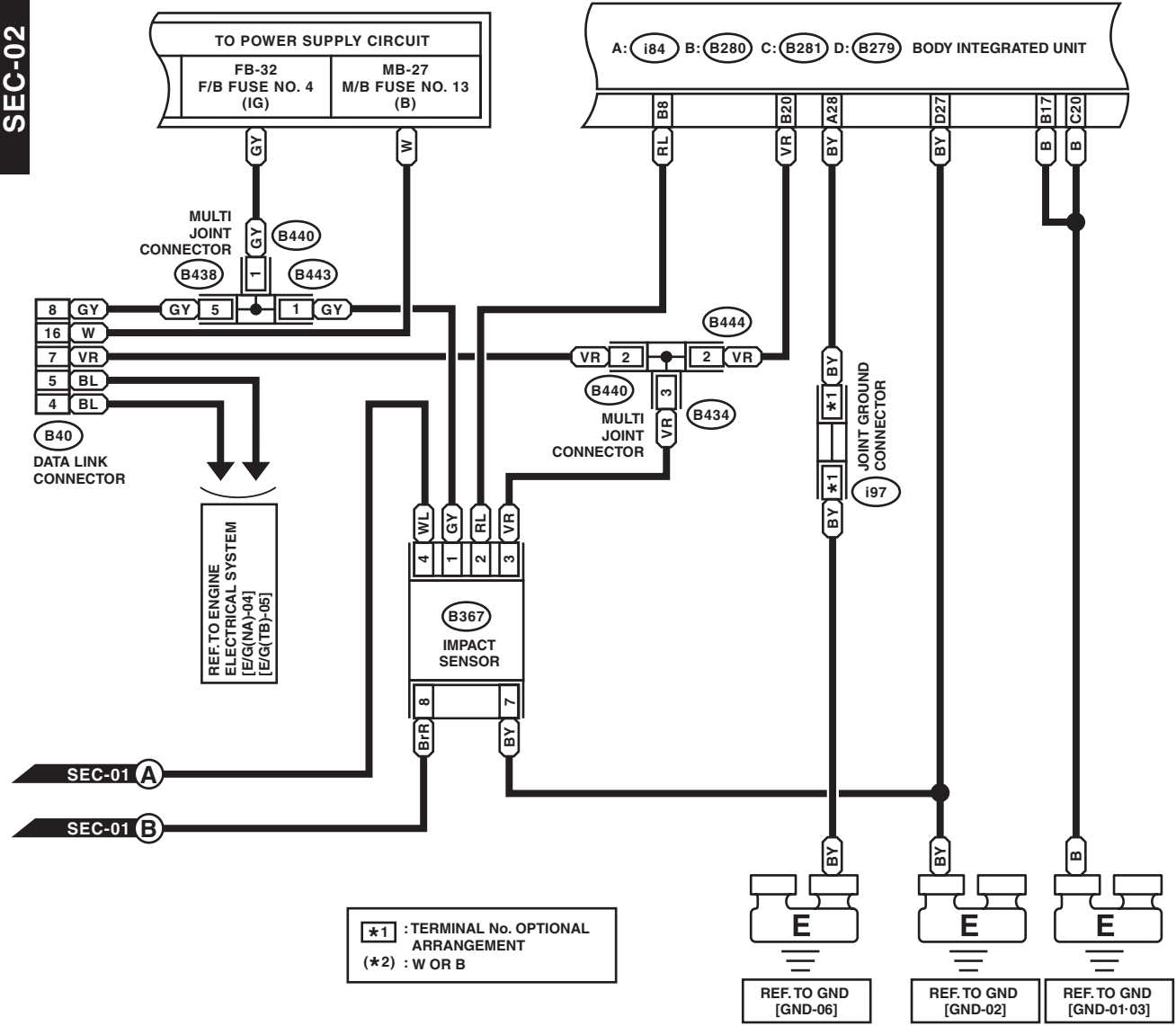

WI-18770

# Security System

Brought to you by Eris Studios  
NOT FOR RESALE

## WIRING SYSTEM

SEC-03

SEC-03

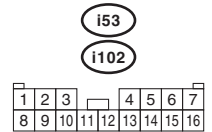
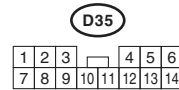
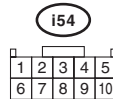
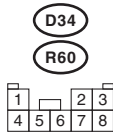
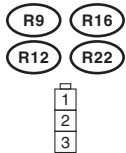
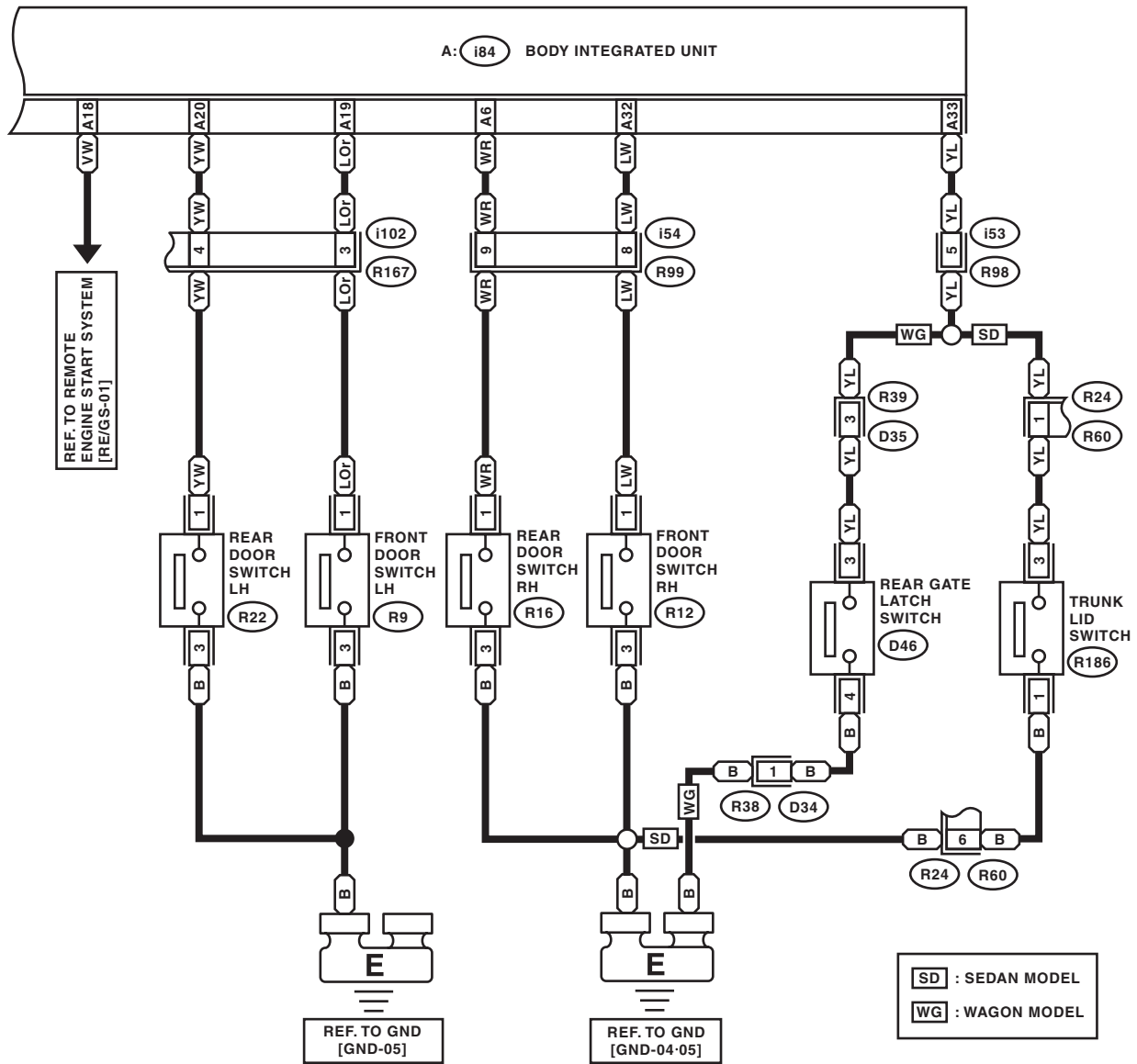

A: i84

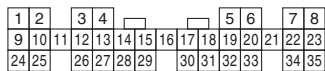

WI-16987

Brought to you by *Chris Studios*  
NOT FOR SALE

## 46. Immobilizer System

### A: WIRING DIAGRAM

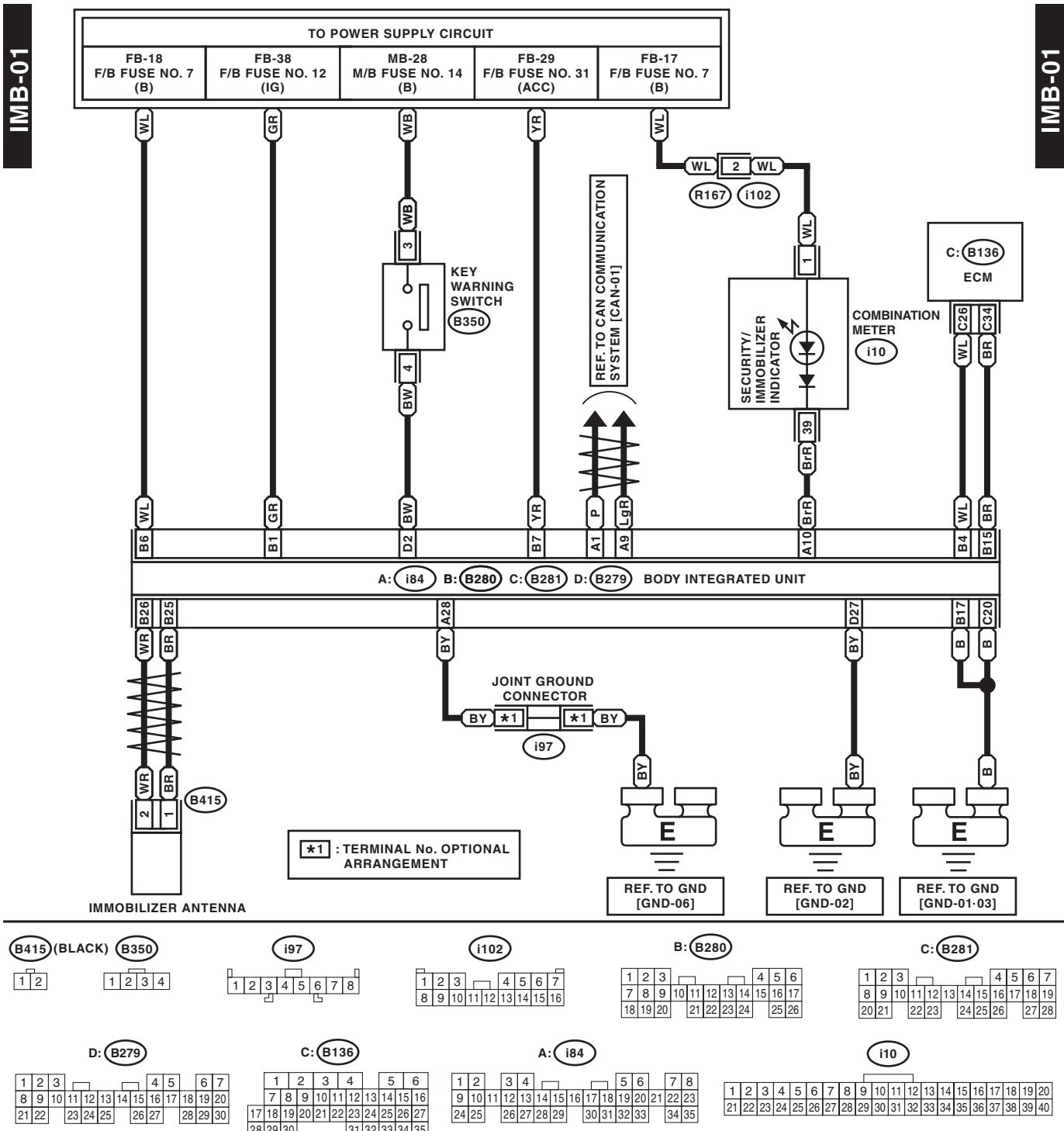

WI-16988

# Keyless Entry System

Brought to you by Eris Studios  
NOT FOR RESALE

## WIRING SYSTEM

### 47. Keyless Entry System

#### A: WIRING DIAGRAM

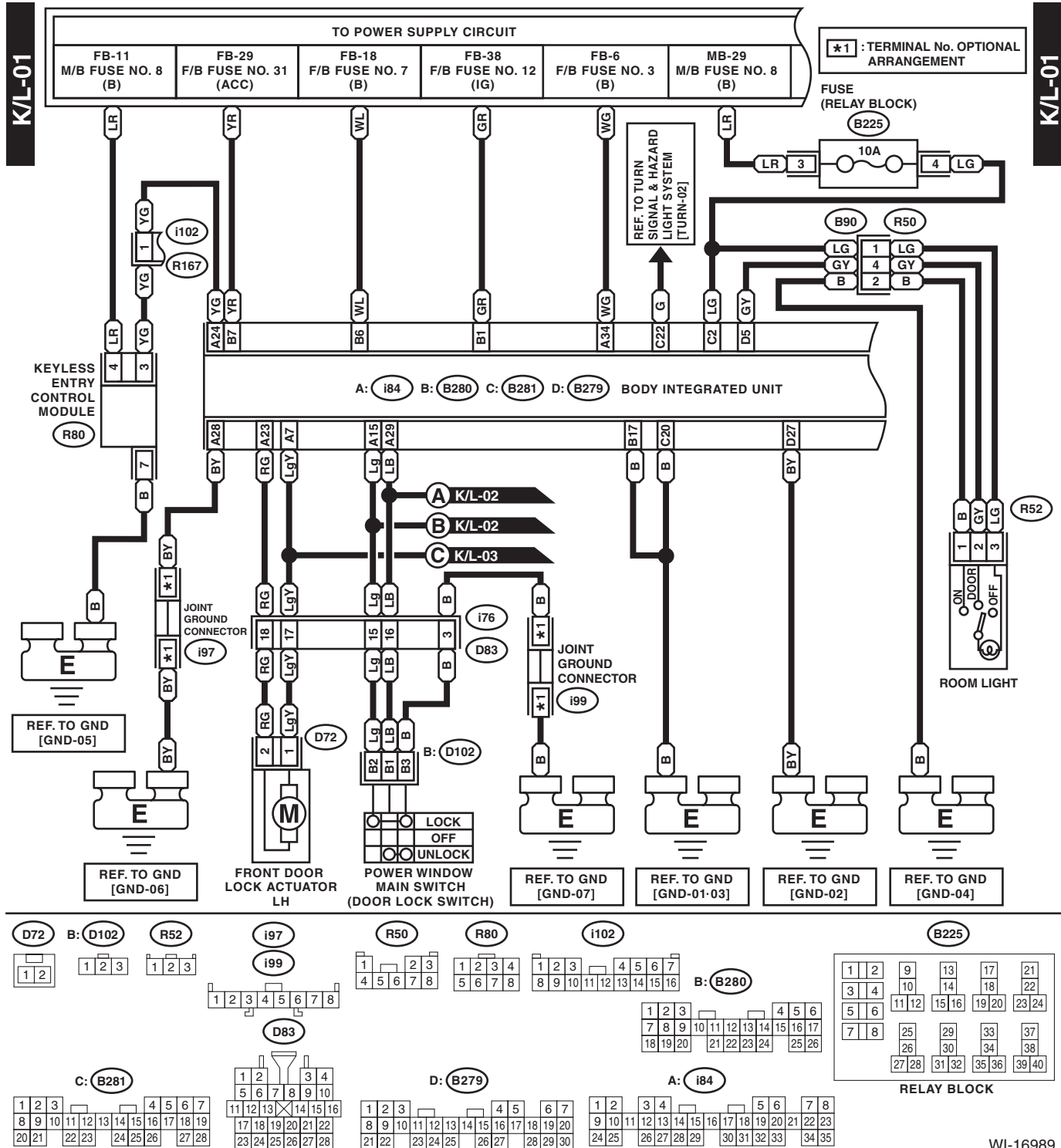

WI-16989

# Keyless Entry System

## WIRING SYSTEM

Brought to you by *Chris Studios*  
NOT FOR SALE

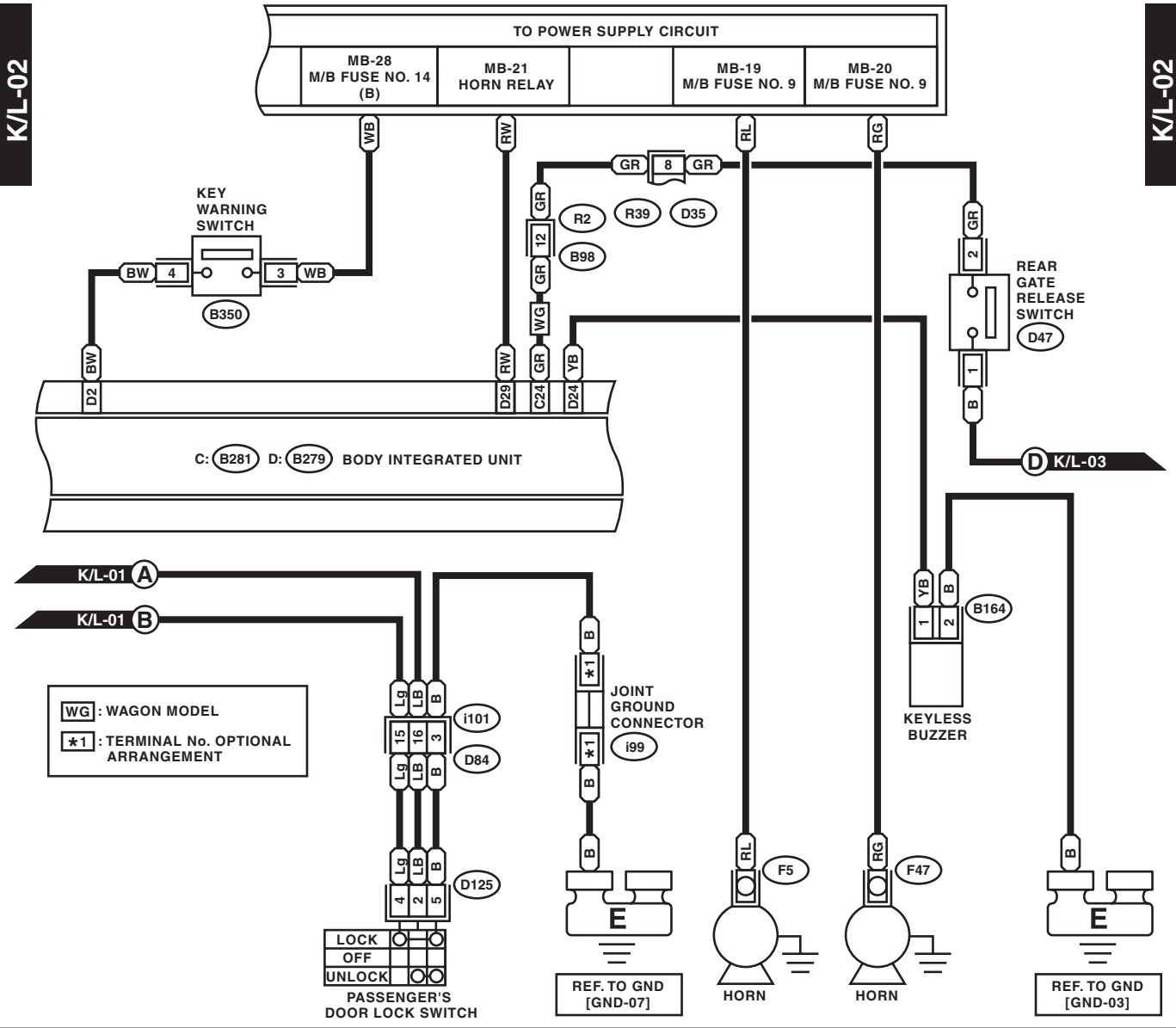

WG : WAGON MODEL  
\*1 : TERMINAL No. OPTIONAL ARRANGEMENT

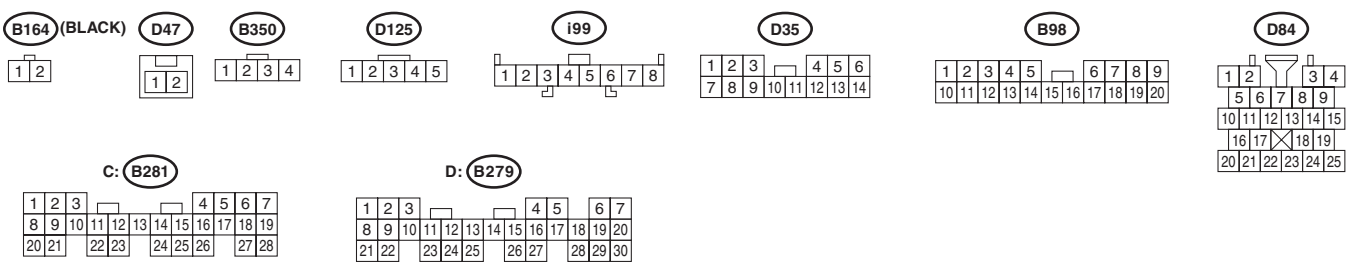

WI-16990

# Keyless Entry System

Brought to you by Eris Studios  
NOT FOR RESALE

## WIRING SYSTEM

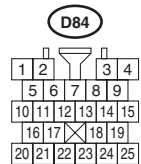
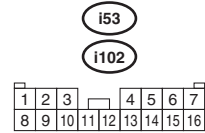
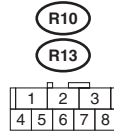
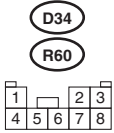
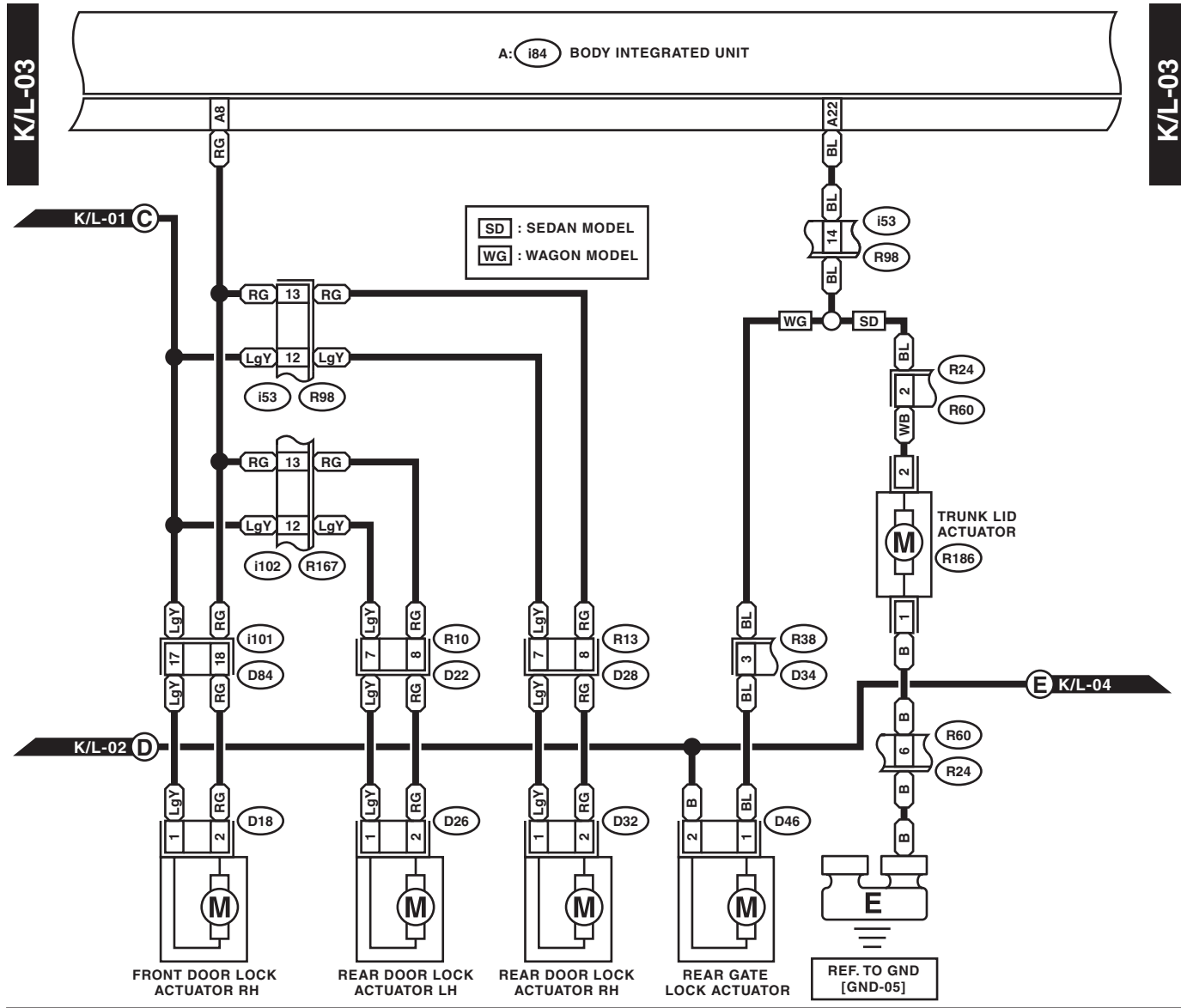

A: **i84**

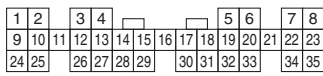

WI-16991



# Keyless Entry System

## WIRING SYSTEM

Brought to you by *Keyless Studios*  
 NOT FOR SALE

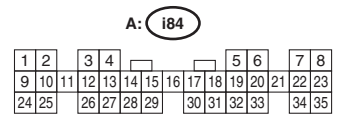
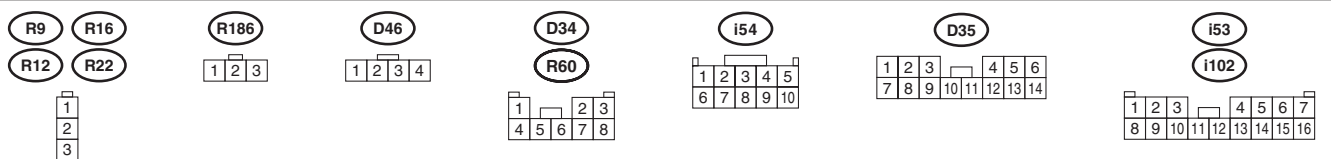
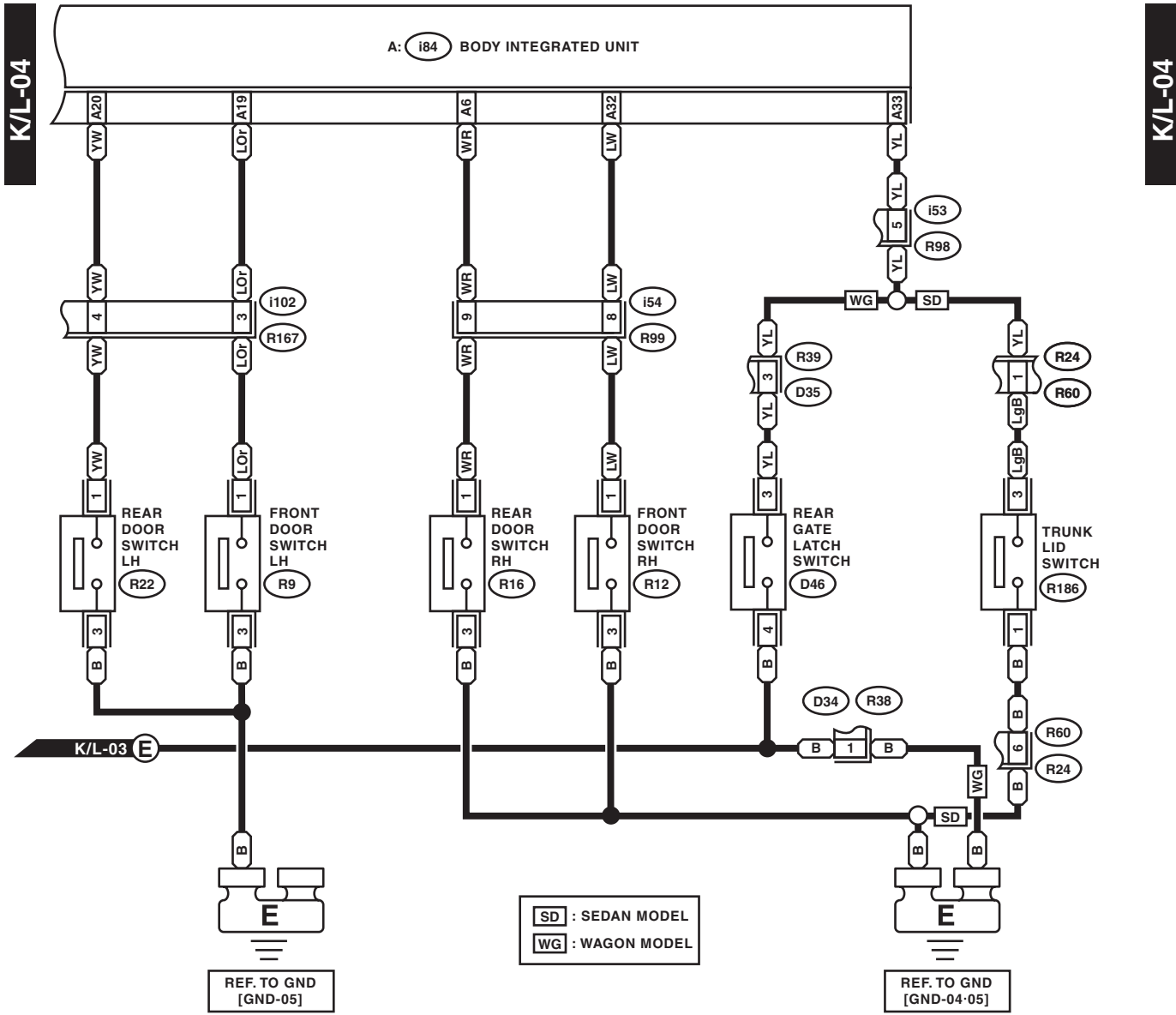

WI-16992

# Cruise Control System

WIRING SYSTEM

Brought to you by Eris Studios  
NOT FOR RESALE

## 48. Cruise Control System

### A: WIRING DIAGRAM

#### 1. NON-TURBO MODEL

- Transmission serial No. 4078112 or earlier

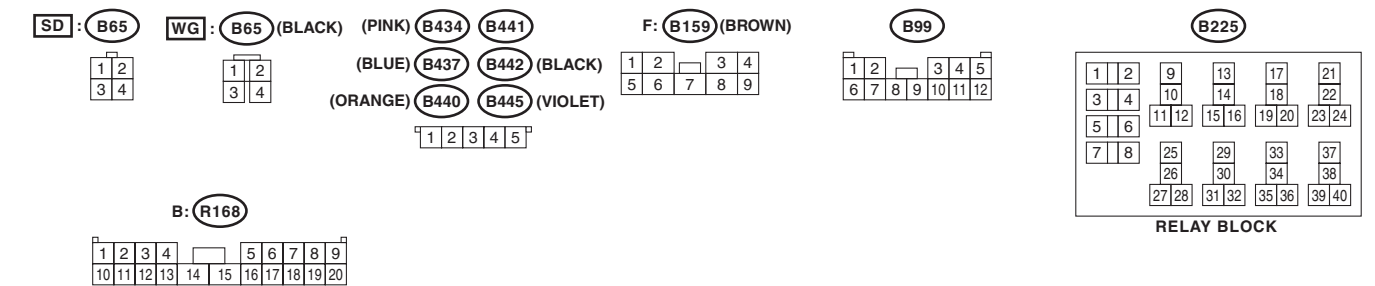
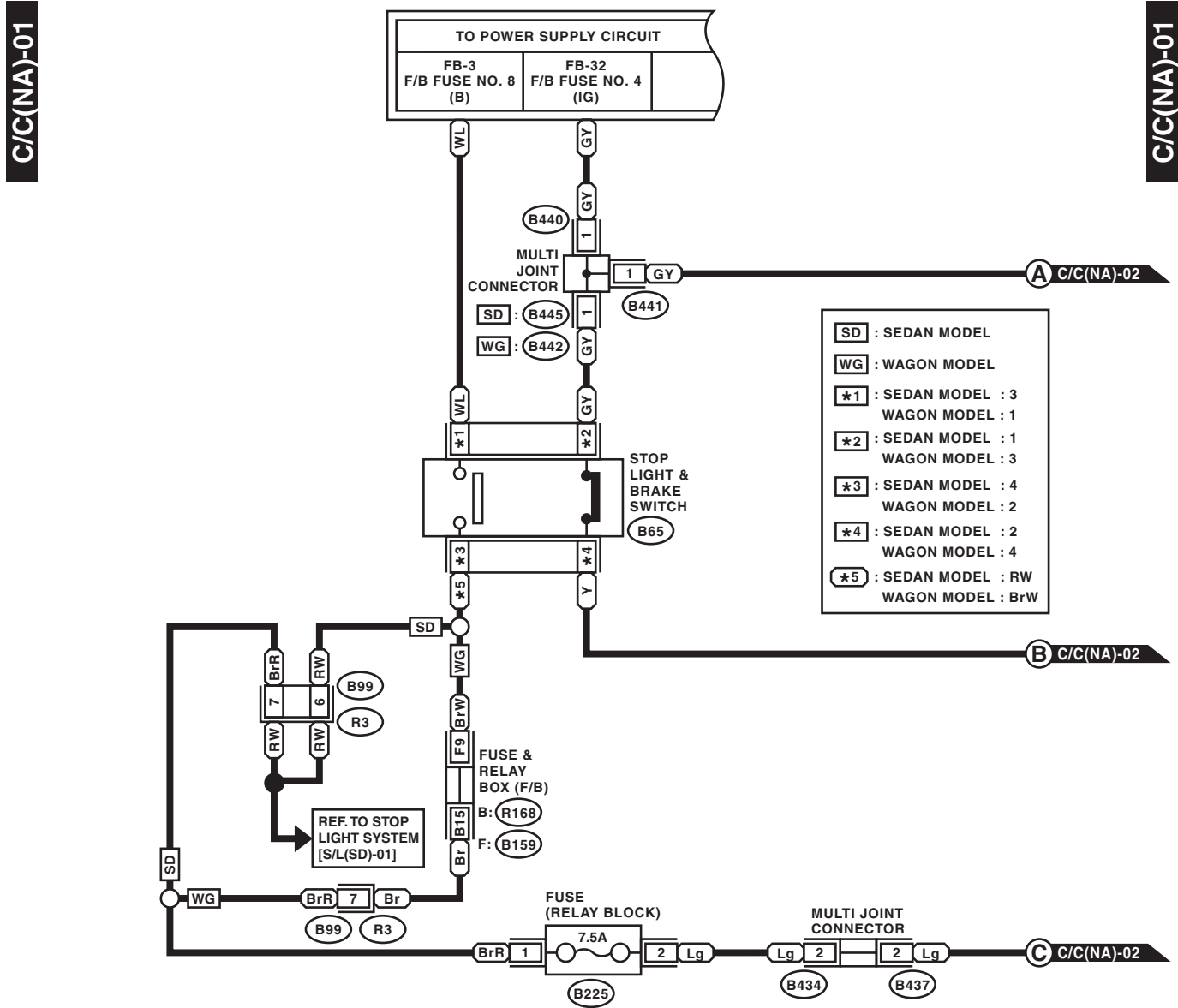

WI-16993

# Cruise Control System

WIRING SYSTEM

Brought to you by *Chris Studios*  
NOT FOR SALE

C/C(NA)-02

C/C(NA)-02

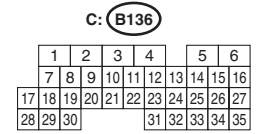
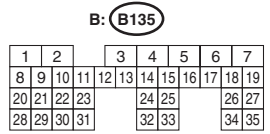
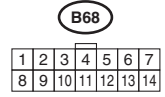
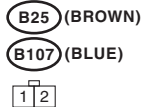
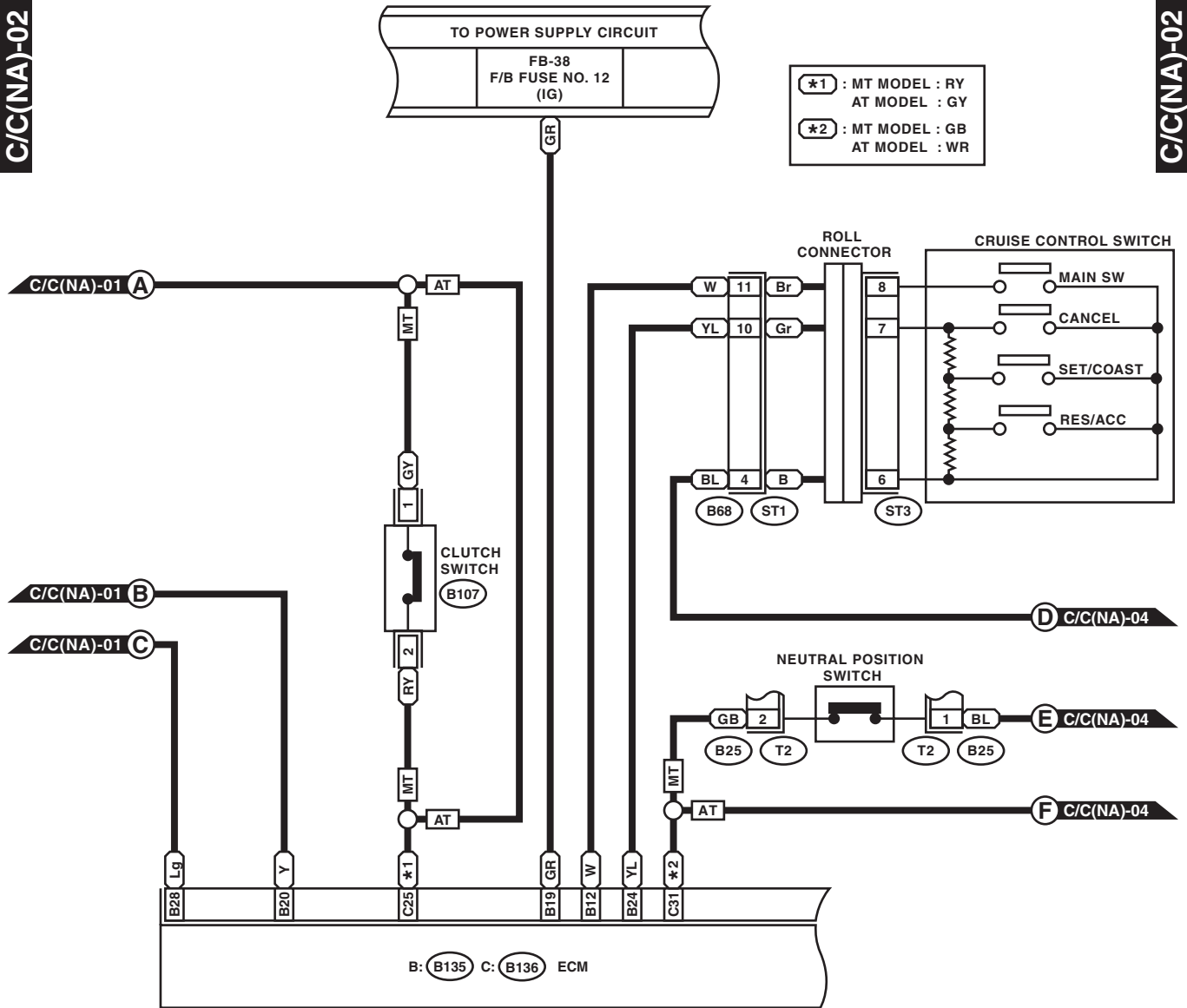

WI-16994

# Cruise Control System

Brought to you by Eris Studios  
NOT FOR RESALE

## WIRING SYSTEM

C/C(NA)-03

C/C(NA)-03

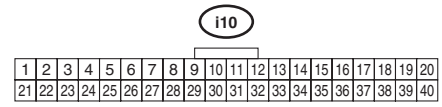
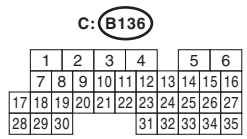
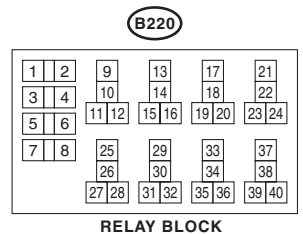
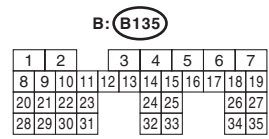
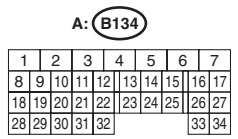
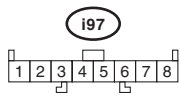
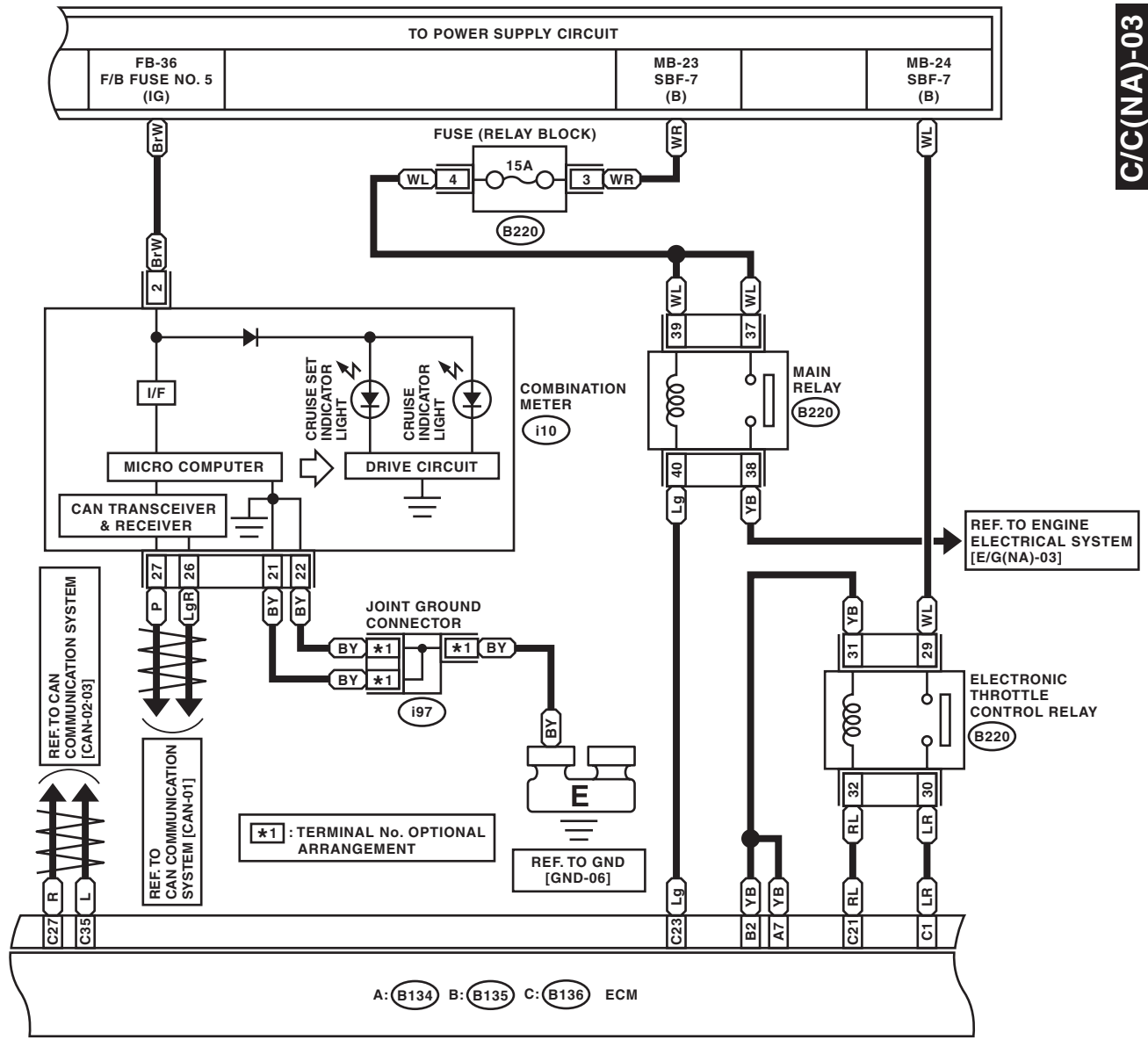

WI-16995

# Cruise Control System

WIRING SYSTEM

Brought to you by *Chris Studios*  
NOT FOR SALE

C/C(NA)-04

C/C(NA)-04

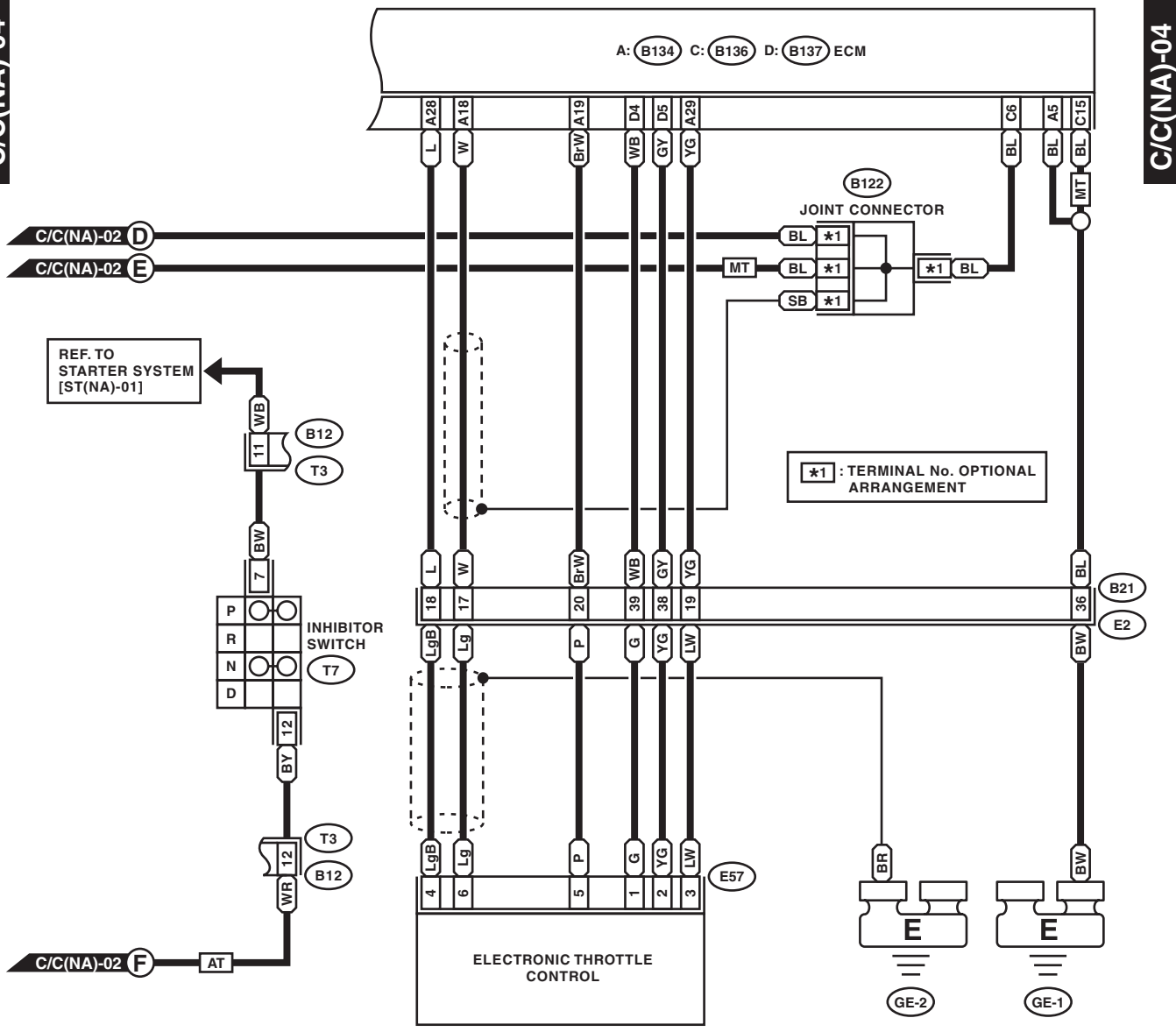

REF. TO STARTER SYSTEM [ST(NA)-01]

\*1 : TERMINAL No. OPTIONAL ARRANGEMENT

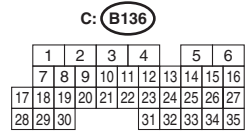
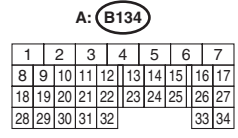
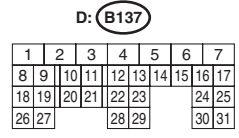
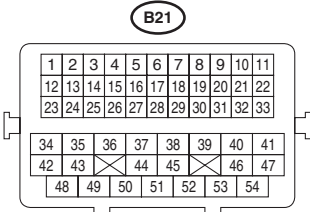
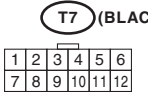
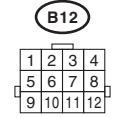
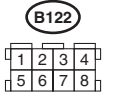
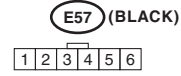

WI-16996

# Cruise Control System

## WIRING SYSTEM

Brought to you by Eris Studios  
NOT FOR RESALE

- Transmission serial No. 4078113 or later

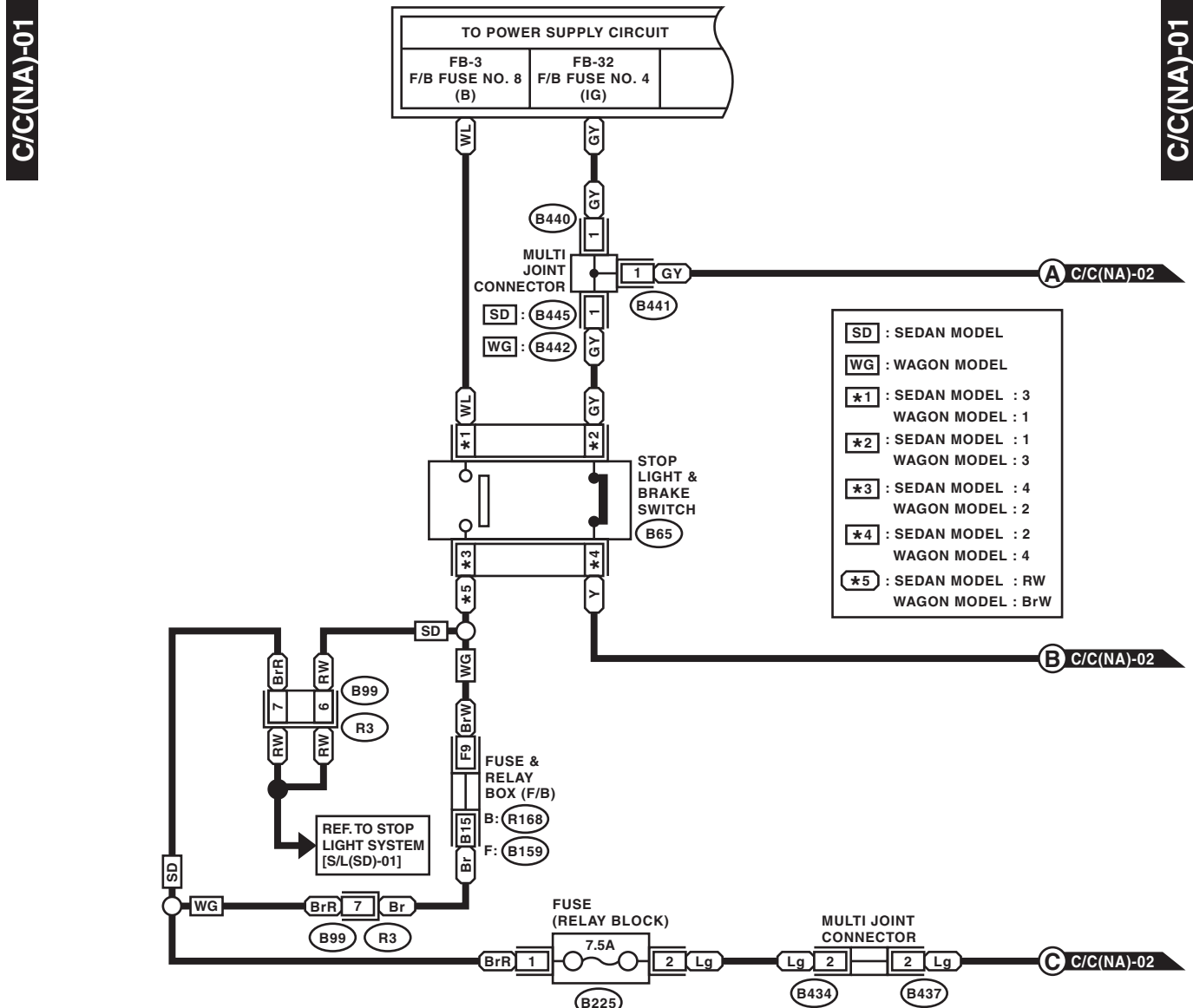

- SD** : SEDAN MODEL
- WG** : WAGON MODEL
- \*1** : SEDAN MODEL : 3  
WAGON MODEL : 1
- \*2** : SEDAN MODEL : 1  
WAGON MODEL : 3
- \*3** : SEDAN MODEL : 4  
WAGON MODEL : 2
- \*4** : SEDAN MODEL : 2  
WAGON MODEL : 4
- \*5** : SEDAN MODEL : RW  
WAGON MODEL : BrW

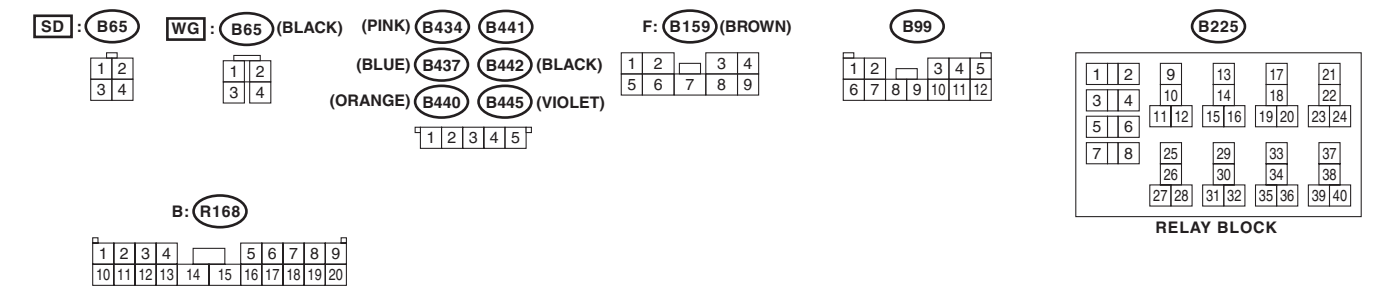

WI-16993

# Cruise Control System

WIRING SYSTEM

Brought to you by *Chris Studios*  
NOT FOR SALE

C/C(NA)-02

C/C(NA)-02

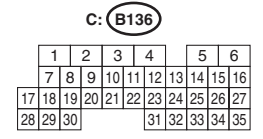
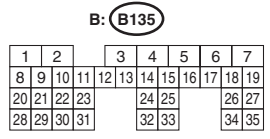
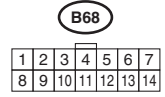
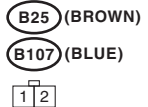
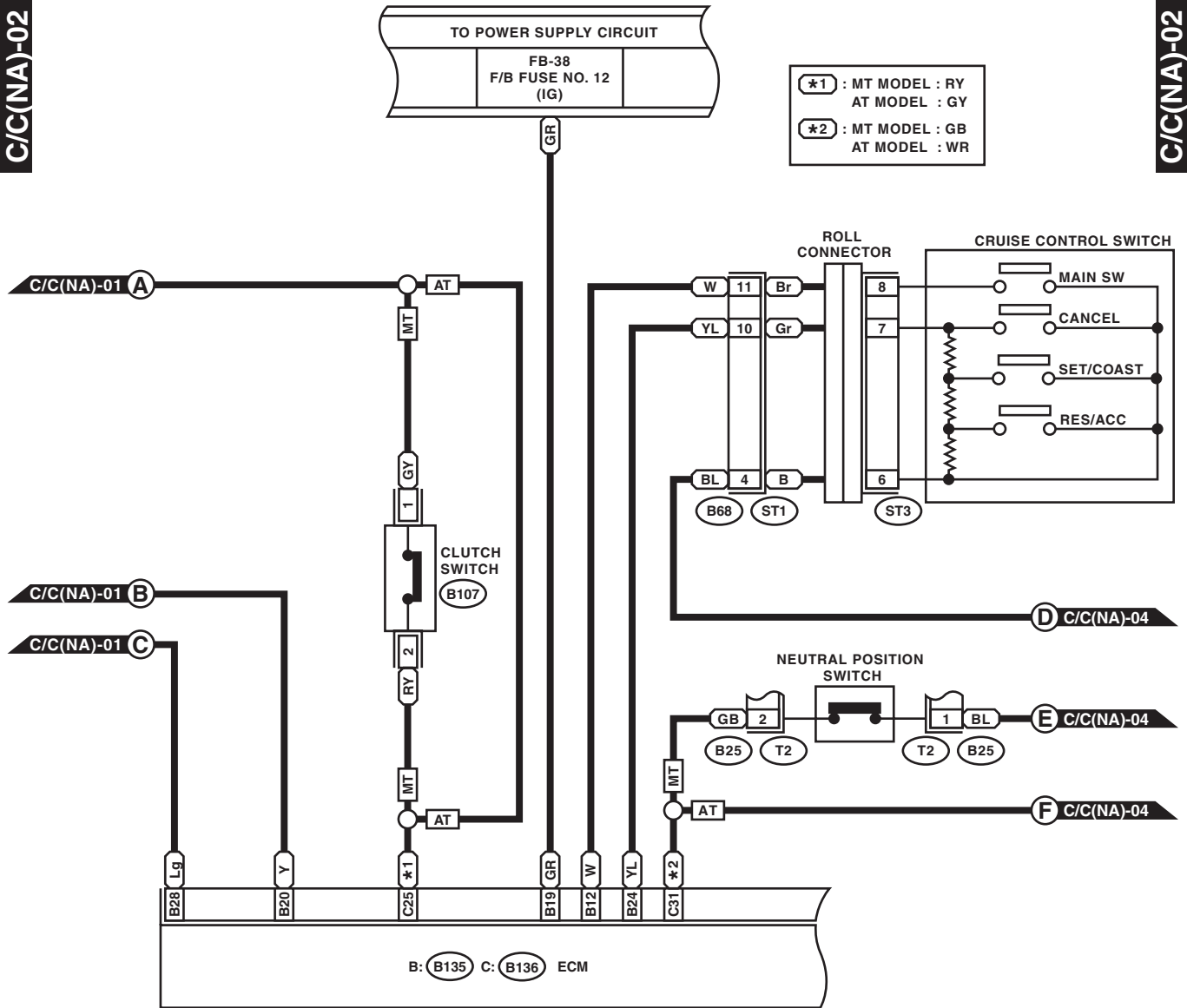

WI-16994

# Cruise Control System

Brought to you by Eris Studios  
NOT FOR RESALE

## WIRING SYSTEM

C/C(NA)-03

C/C(NA)-03

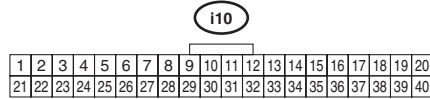
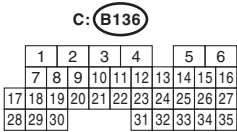
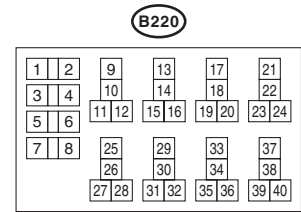
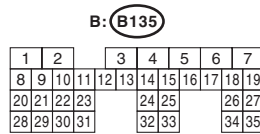
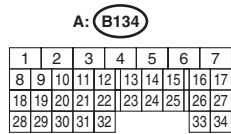
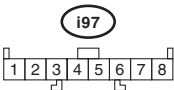
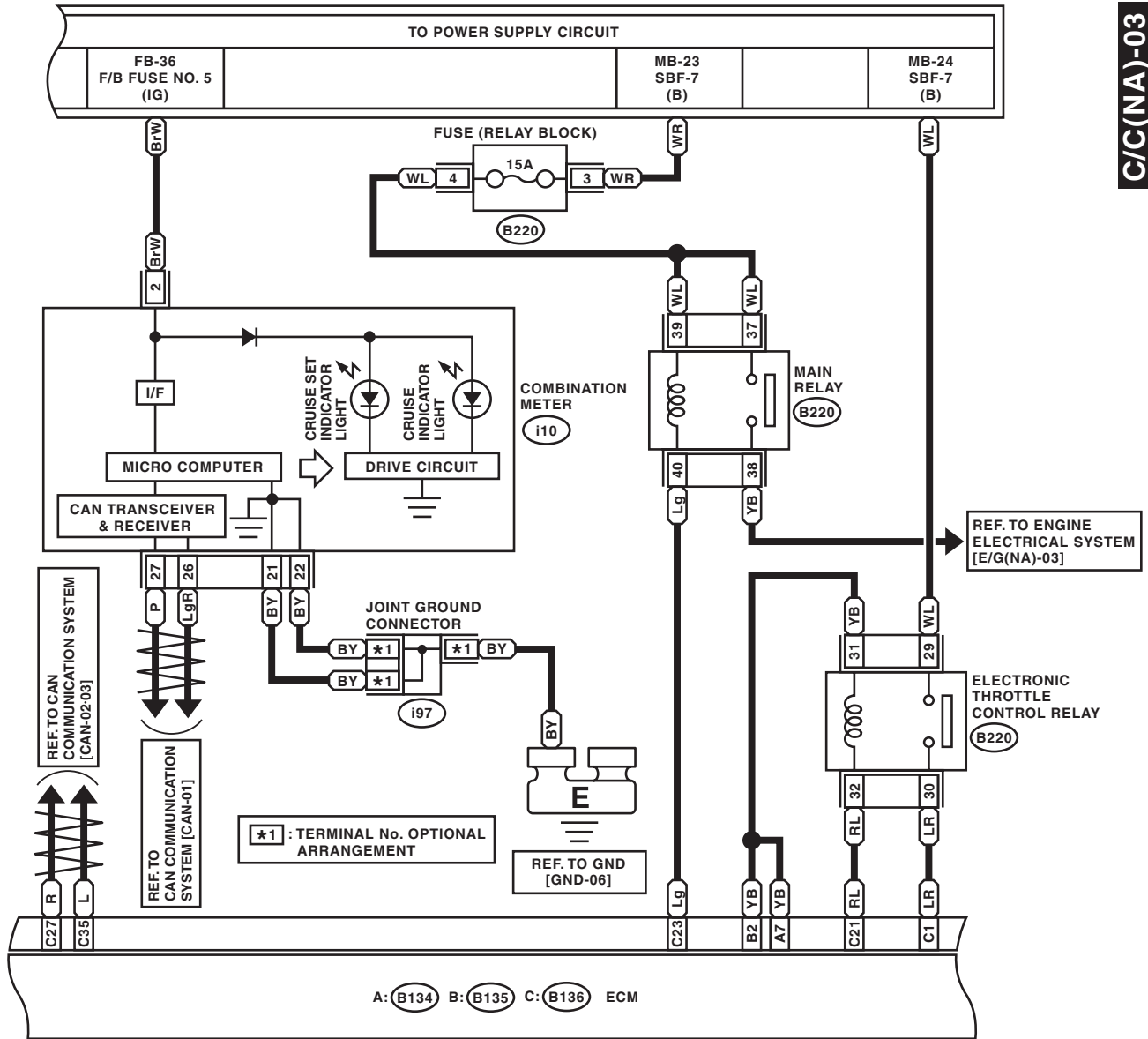

WI-16995



# Cruise Control System

WIRING SYSTEM

Brought to you by *Chris Studios*  
NOT FOR SALE

C/C(NA)-04

C/C(NA)-04

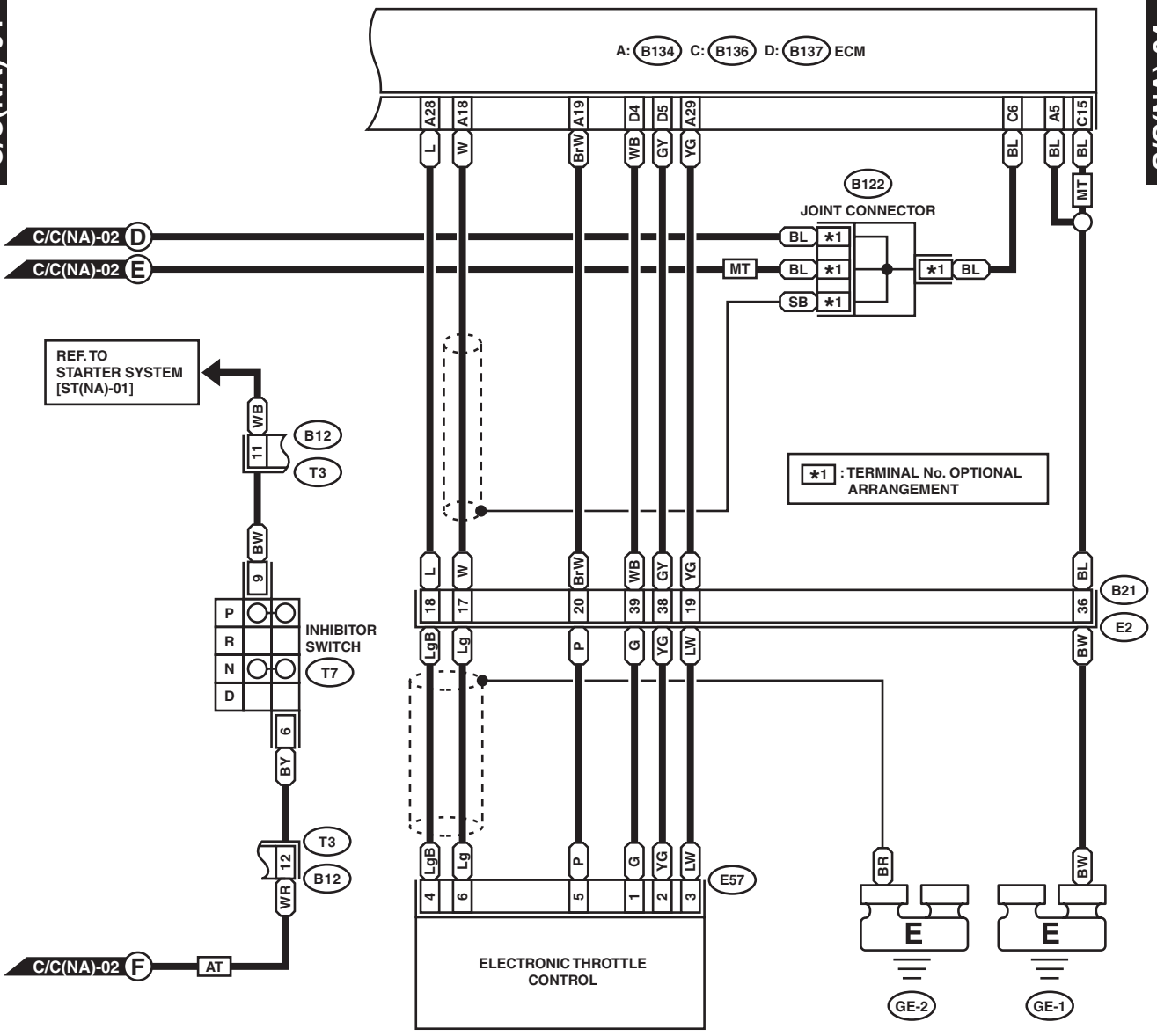

\*1 : TERMINAL No. OPTIONAL ARRANGEMENT

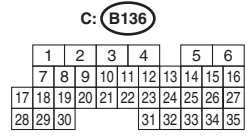
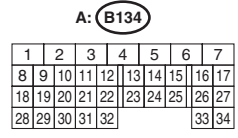
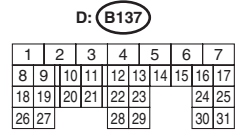
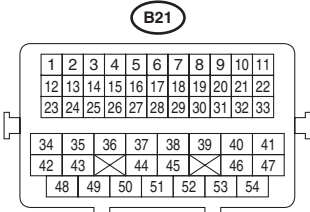
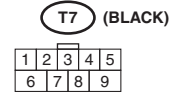
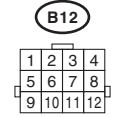
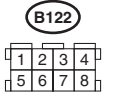
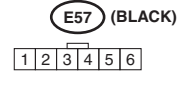

WI-21047

# Cruise Control System

Brought to you by Eris Studios  
NOT FOR RESALE

## WIRING SYSTEM

### 2. TURBO MODEL

- Transmission serial No. 4078112 or earlier

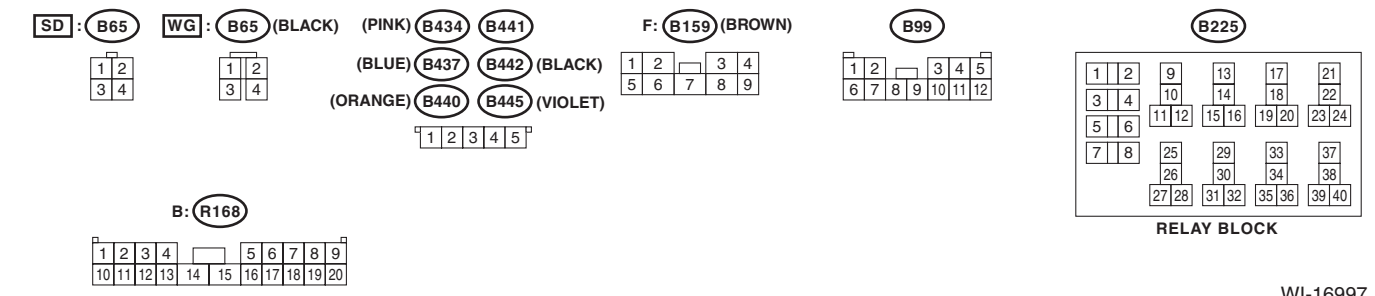
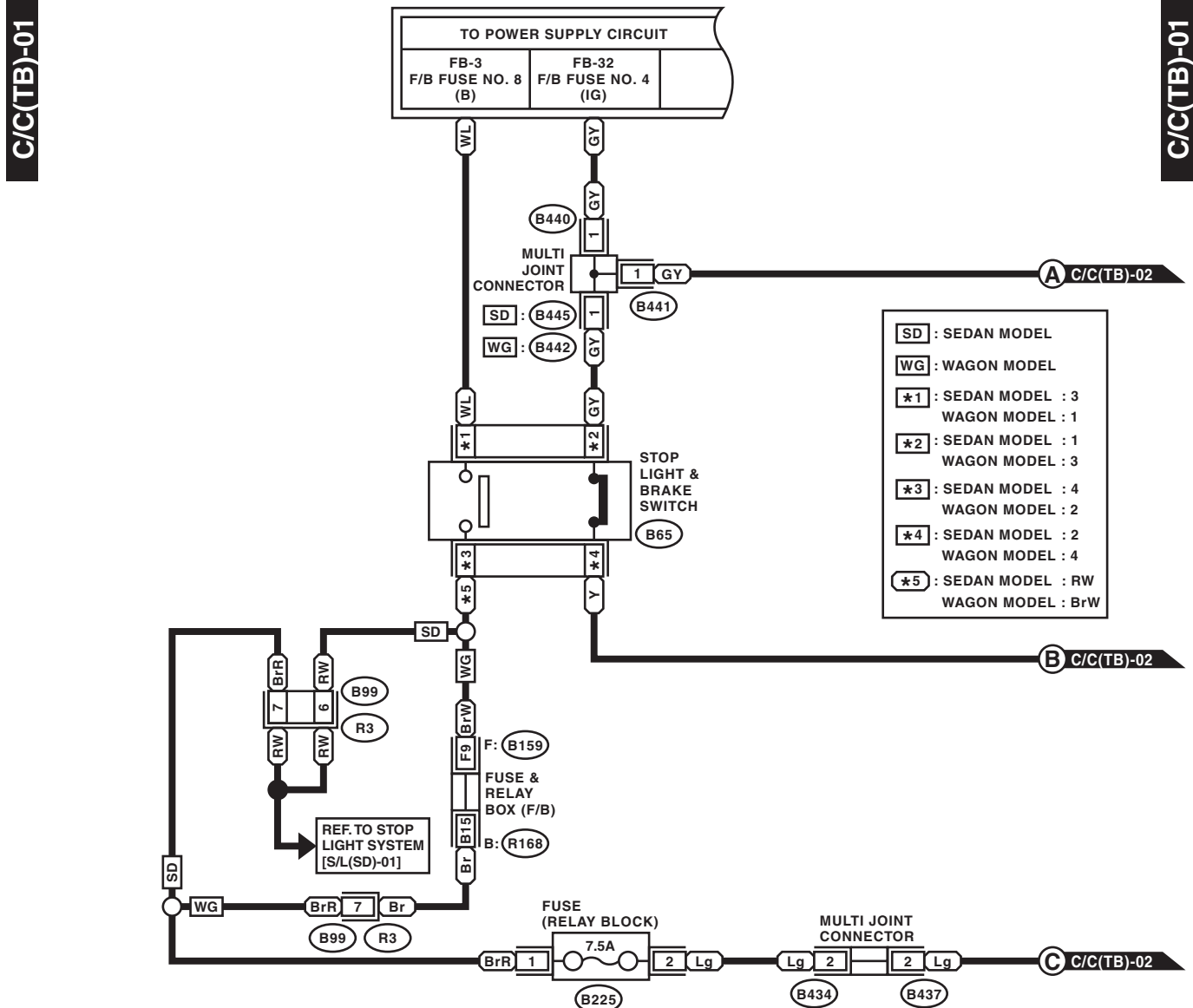

WI-16997

# Cruise Control System

WIRING SYSTEM

Brought to you by *Chris Studios*  
 NOT FOR SALE

C/C(TB)-02

C/C(TB)-02

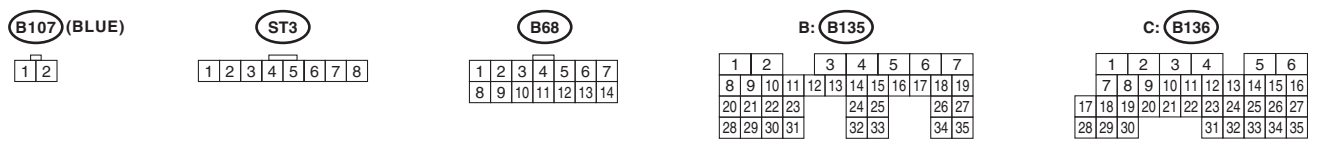
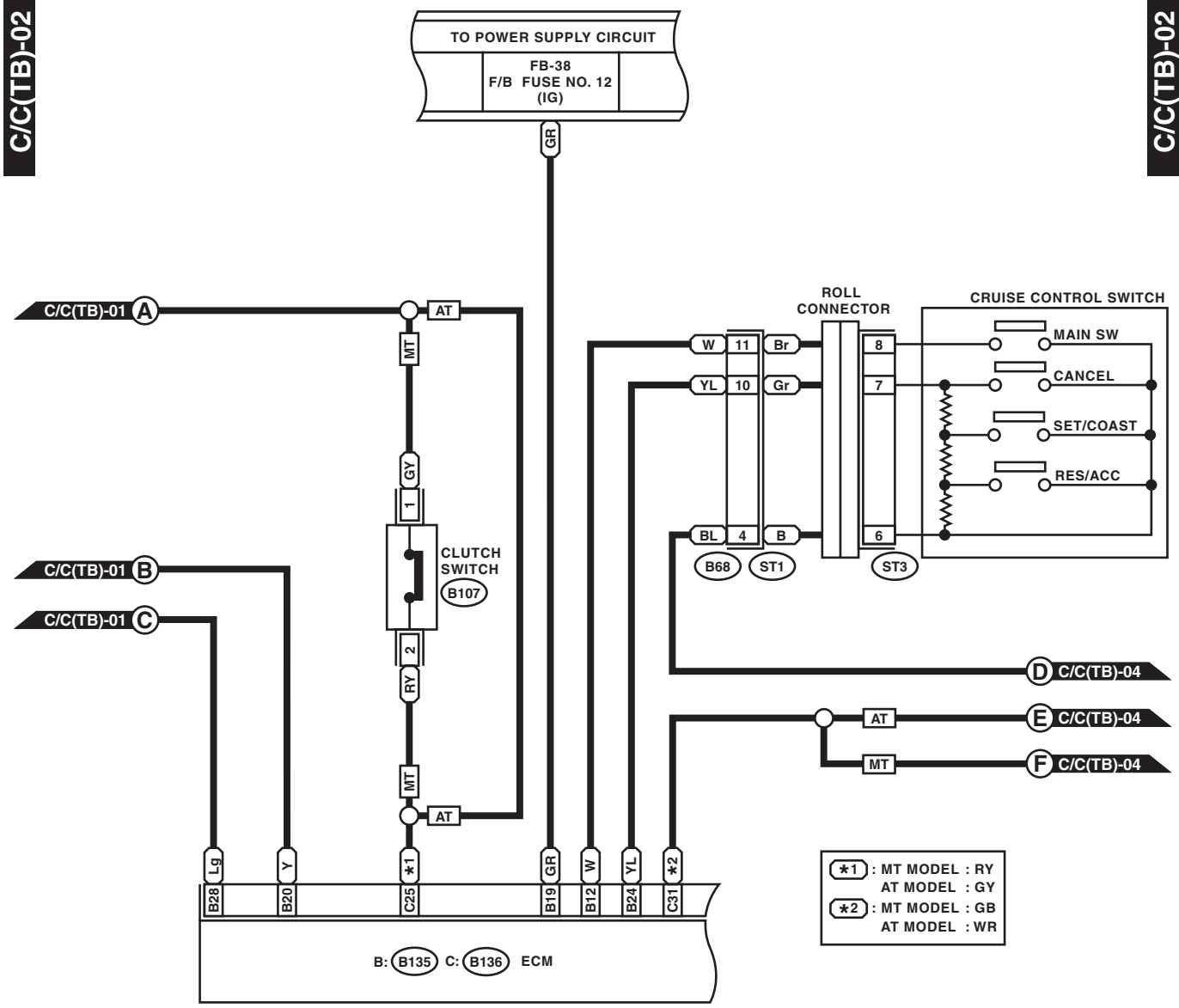

WI-16998

# Cruise Control System

WIRING SYSTEM

Brought to you by Eris Studios  
NOT FOR RESALE

C/C(TB)-03

C/C(TB)-03

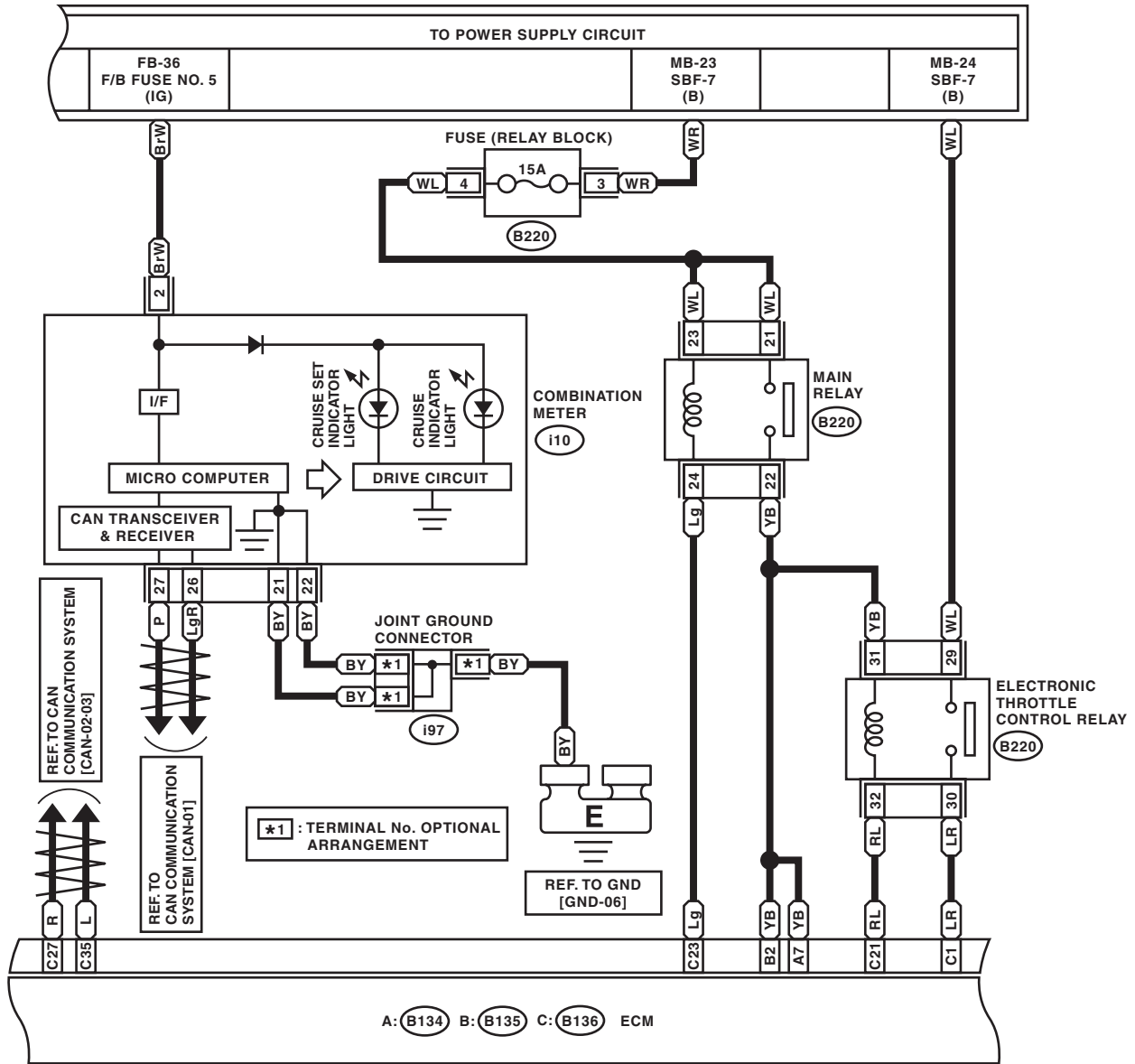

\*1 : TERMINAL No. OPTIONAL ARRANGEMENT

A: (B134) B: (B135) C: (B136) ECM

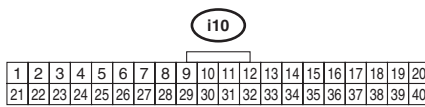
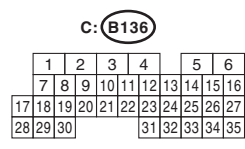
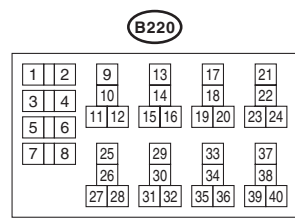
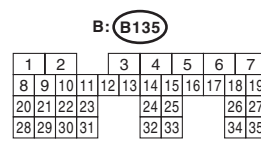
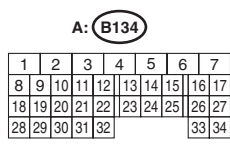
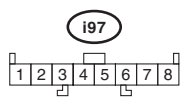

WI-16999

# Cruise Control System

## WIRING SYSTEM

Brought to you by *Chris Studios*  
NOT FOR SALE

C/C(TB)-04

C/C(TB)-04

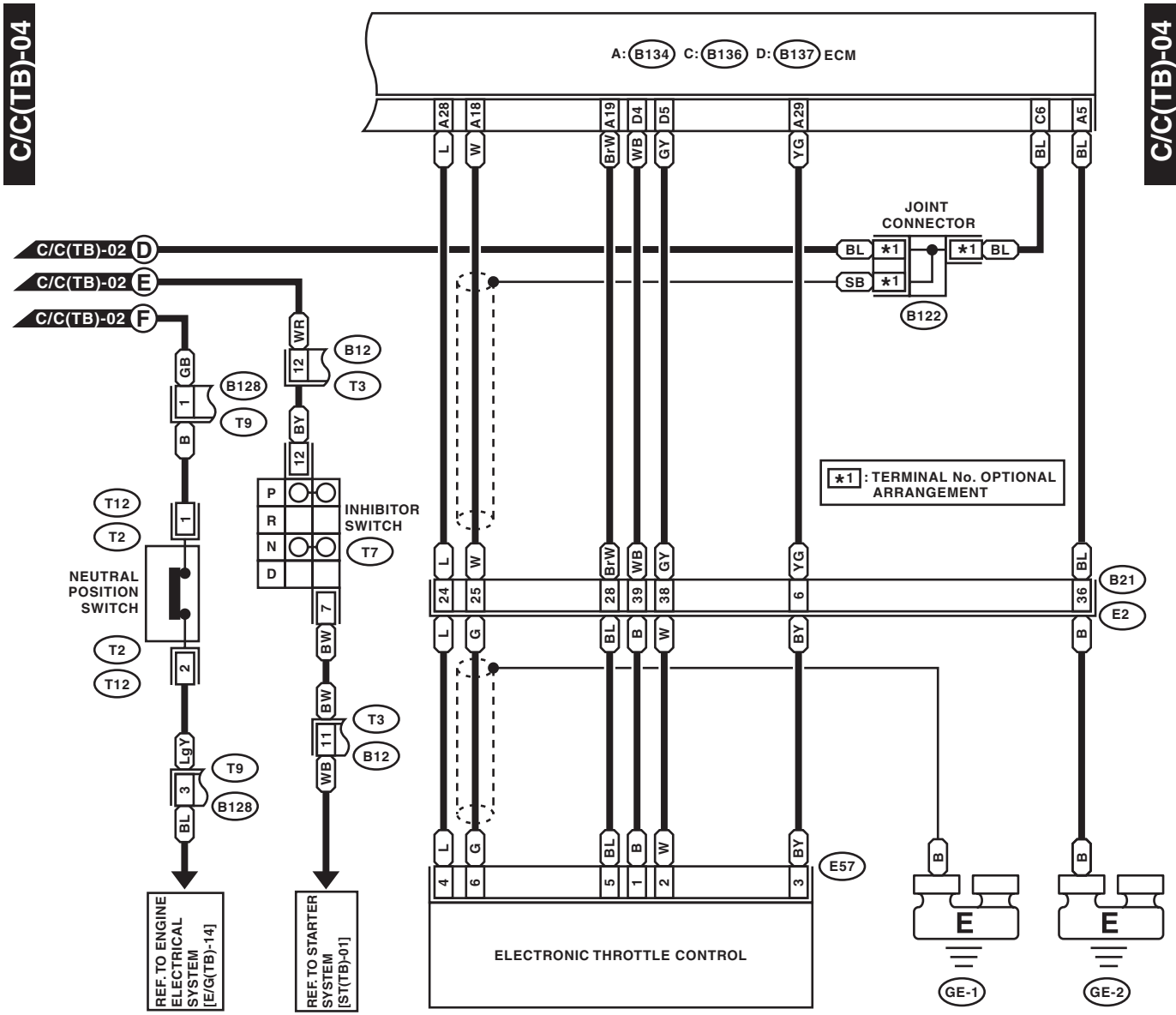

\*1: TERMINAL No. OPTIONAL ARRANGEMENT

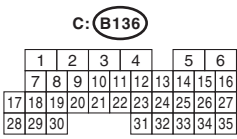
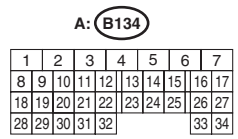
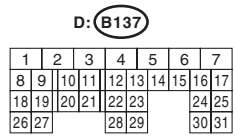
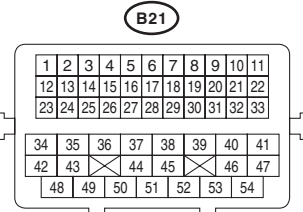
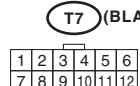
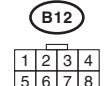
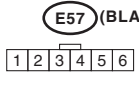

WI-17000

# Cruise Control System

Brought to you by Eris Studios  
NOT FOR RESALE

## WIRING SYSTEM

- Transmission serial No. 4078113 or later

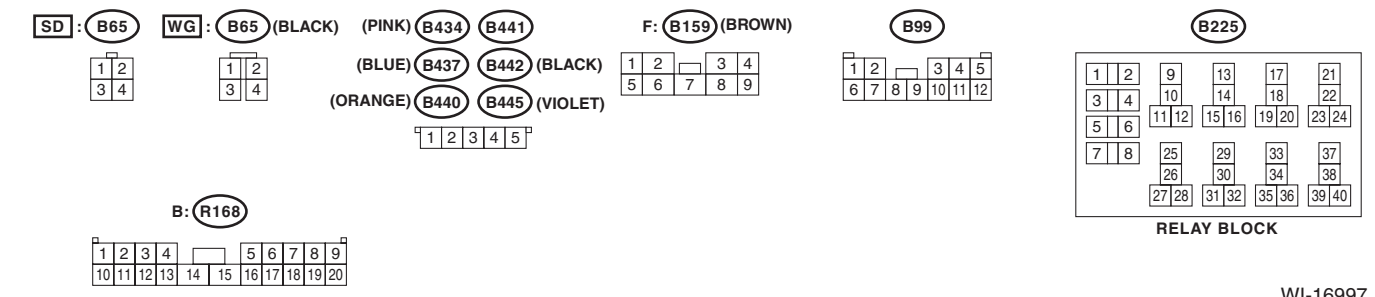
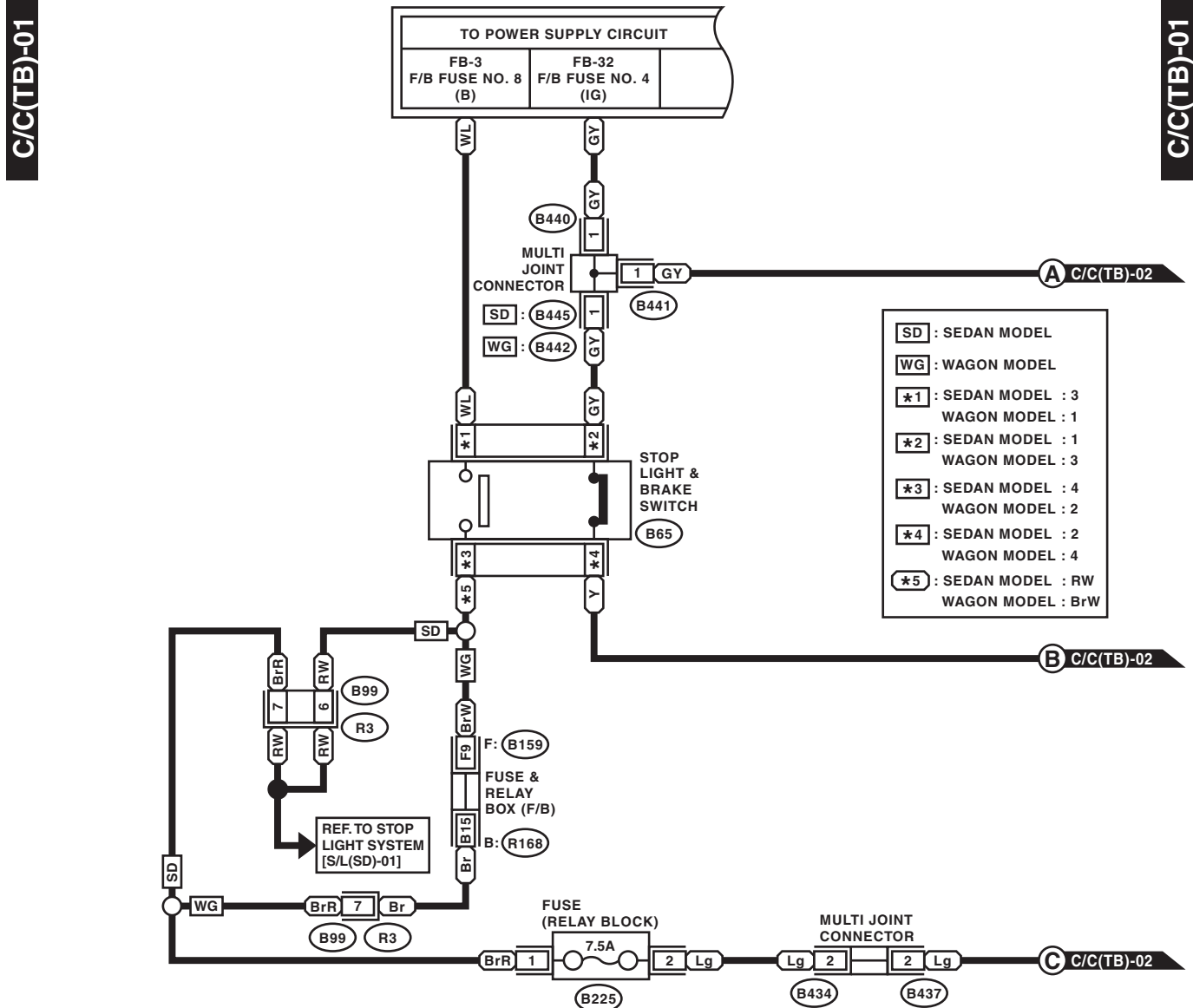

WI-16997

# Cruise Control System

WIRING SYSTEM

Brought to you by *Chris Studios*  
 NOT FOR SALE

C/C(TB)-02

C/C(TB)-02

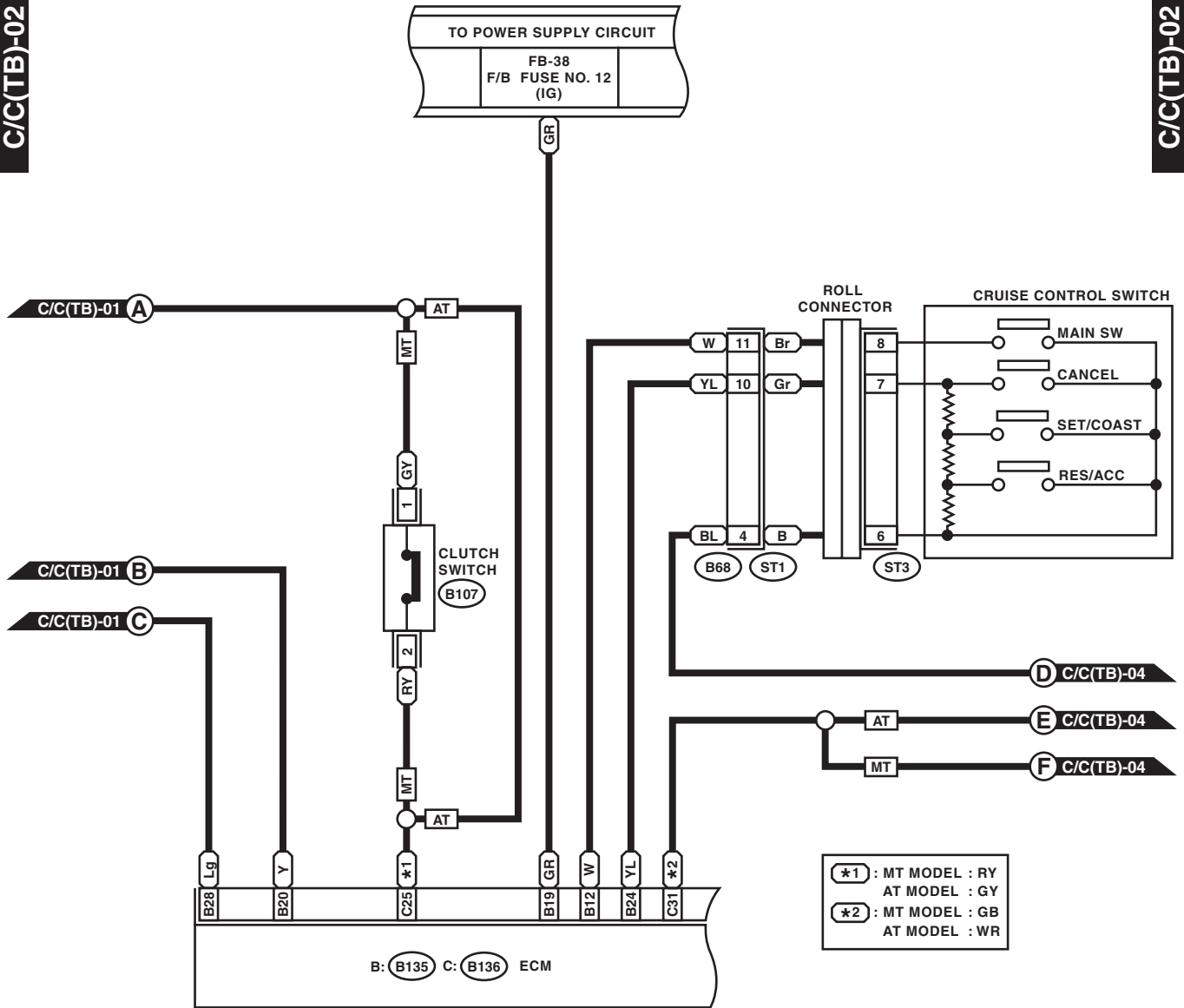

(B107) (BLUE)

1	2
---	---

ST3

1	2	3	4	5	6	7	8
---	---	---	---	---	---	---	---

B68

1	2	3	4	5	6	7
8	9	10	11	12	13	14

B: (B135)

1	2	3	4	5	6	7					
8	9	10	11	12	13	14	15	16	17	18	19
20	21	22	23	24	25	26	27				
28	29	30	31	32	33	34	35				

C: (B136)

1	2	3	4	5	6							
7	8	9	10	11	12	13	14	15	16			
17	18	19	20	21	22	23	24	25	26	27		
28	29	30				31	32	33	34	35		

WI-16998

# Cruise Control System

WIRING SYSTEM

Brought to you by Eris Studios  
NOT FOR RESALE

C/C(TB)-03

C/C(TB)-03

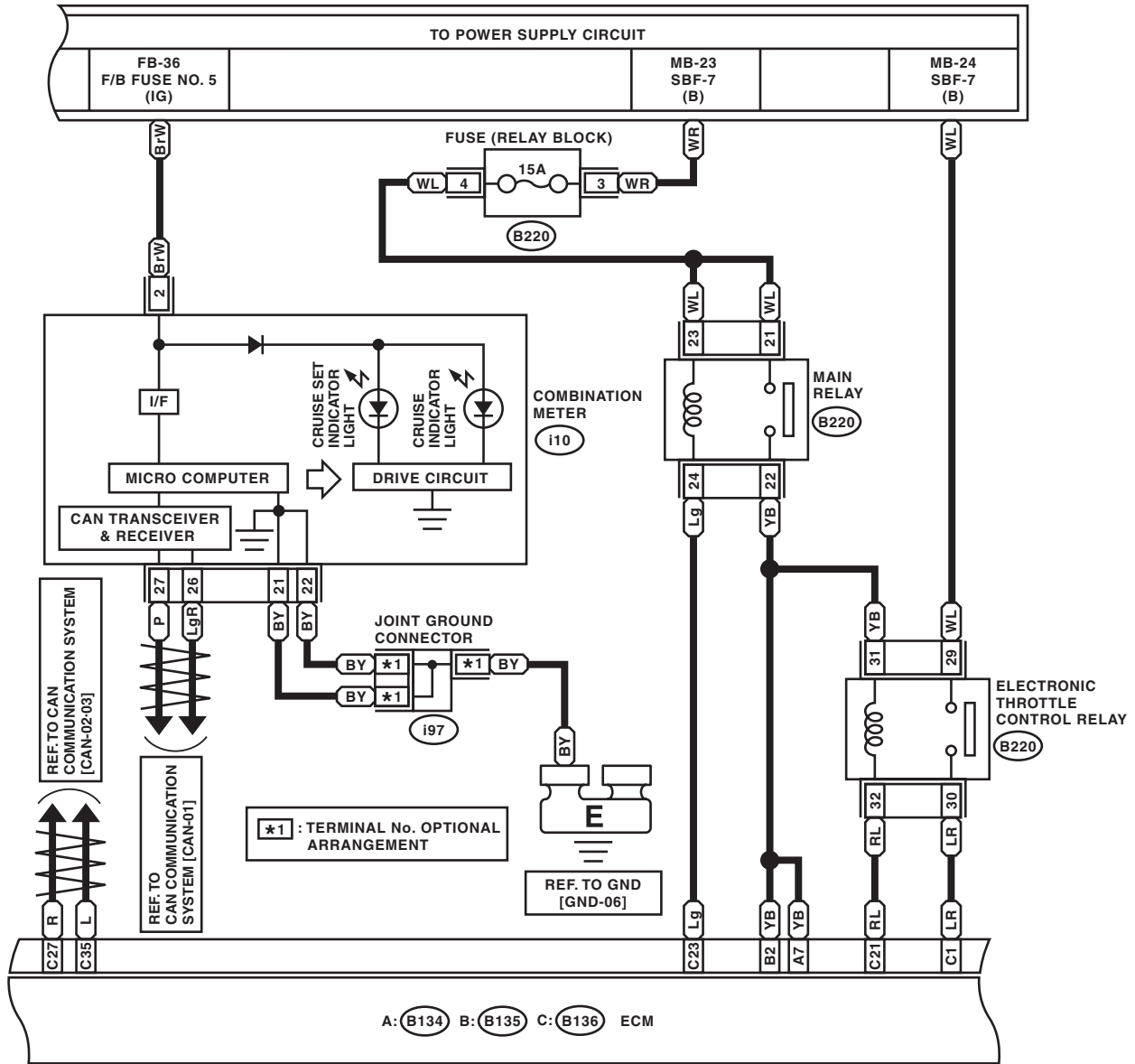

(i97)

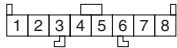

A: (B134)

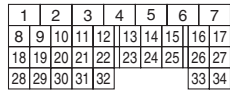

B: (B135)

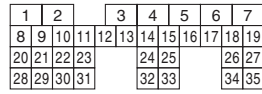

(B220)

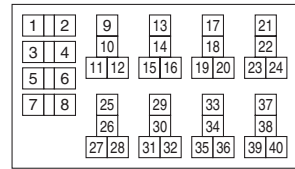

RELAY BLOCK

C: (B136)

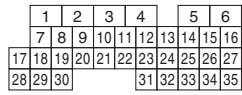

(i10)

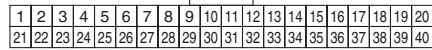

WI-16999



# Cruise Control System

WIRING SYSTEM

Brought to you by *Chris Studios*  
NOT FOR SALE

C/C(TB)-04

C/C(TB)-04

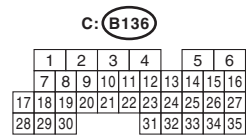
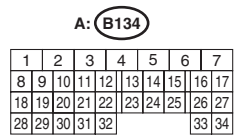
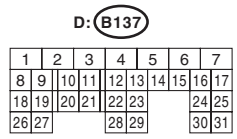
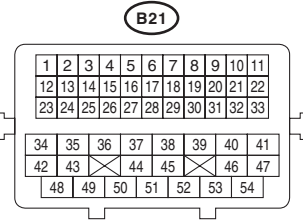
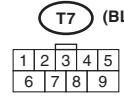
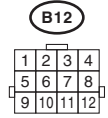
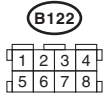
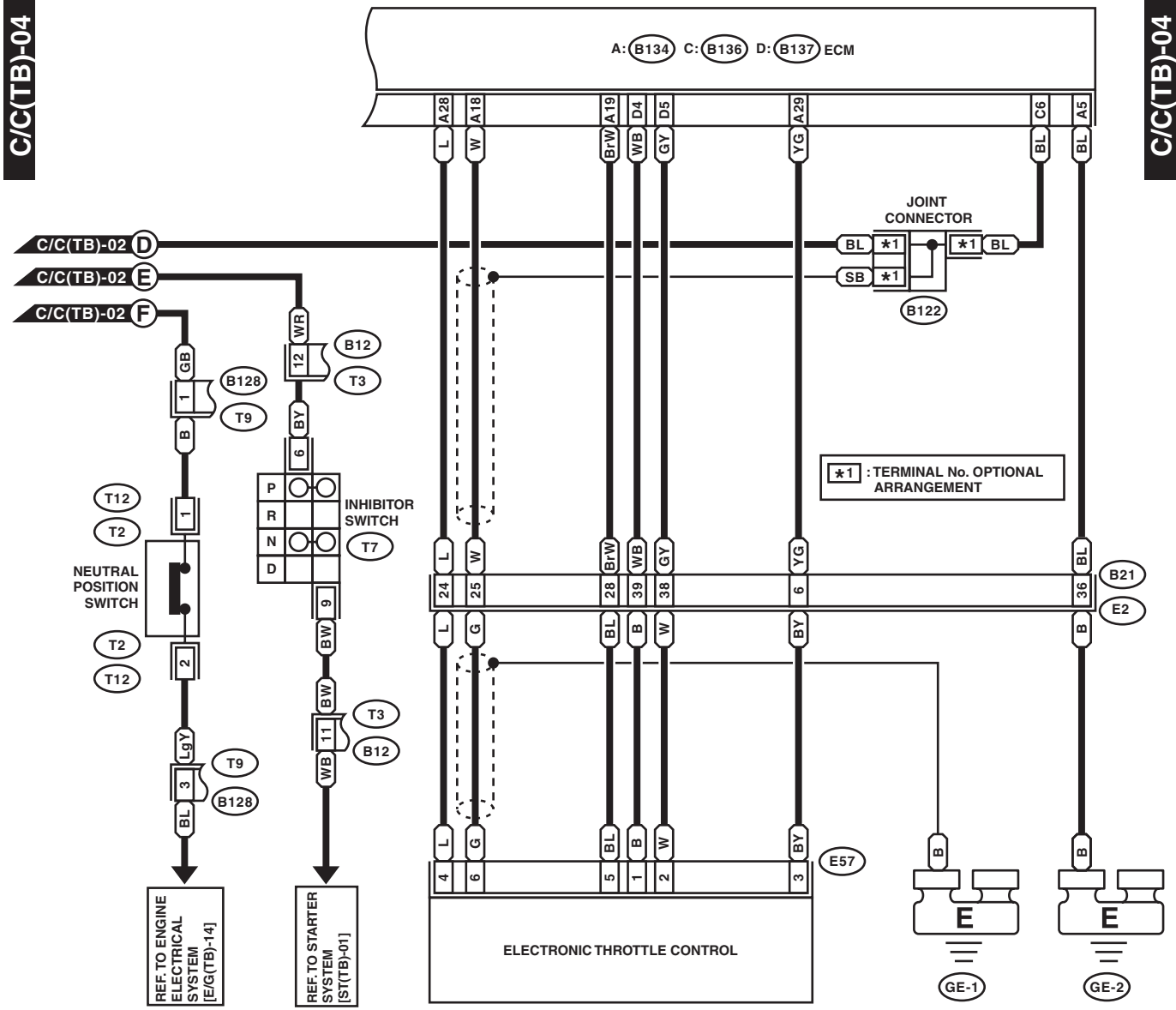

WI-21048

## WIRING SYSTEM

### 49. CAN Communication System

#### A: WIRING DIAGRAM

##### 1. LOW SPEED CAN

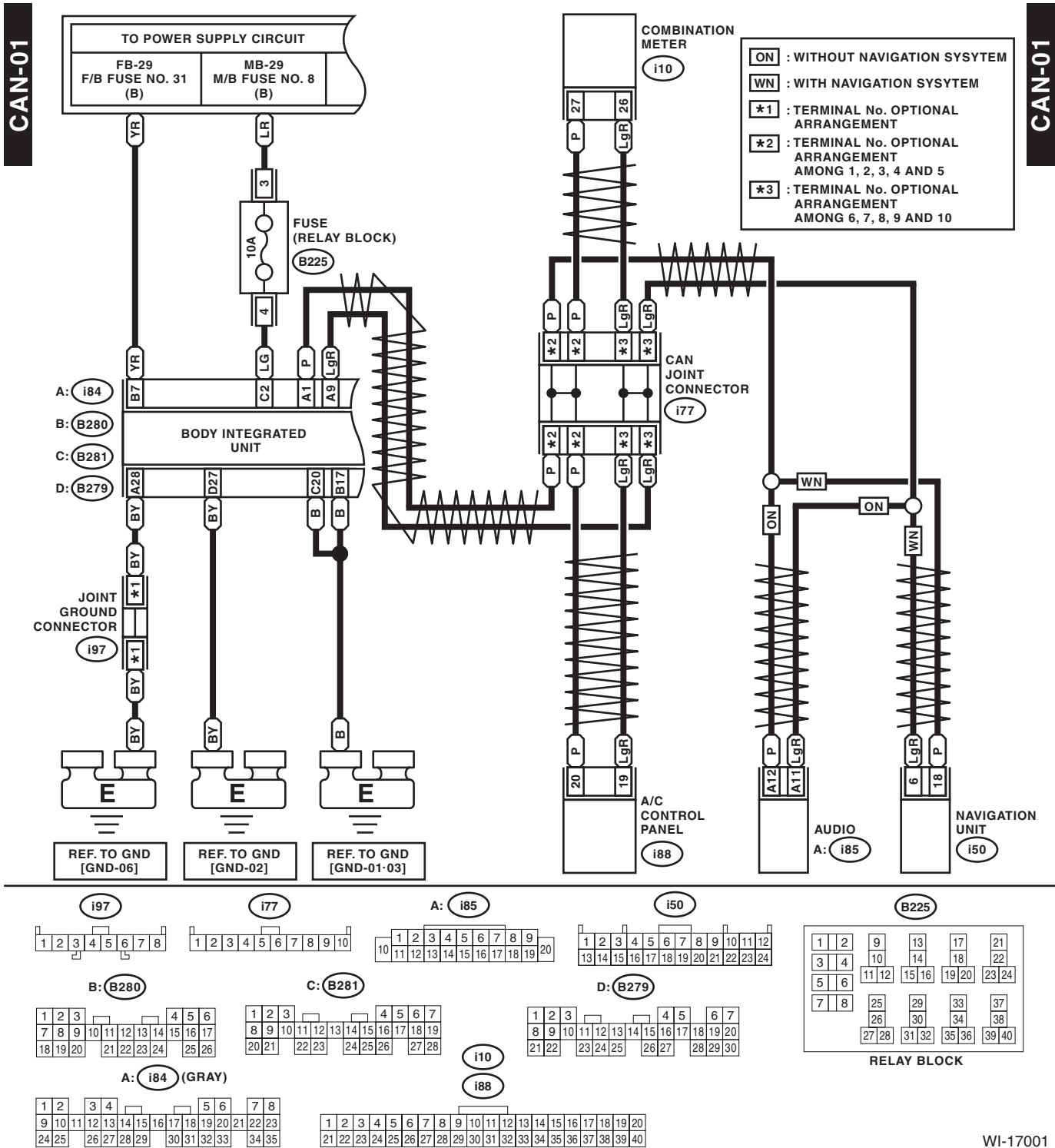

## 2. HIGH SPEED CAN

- Models without VDC

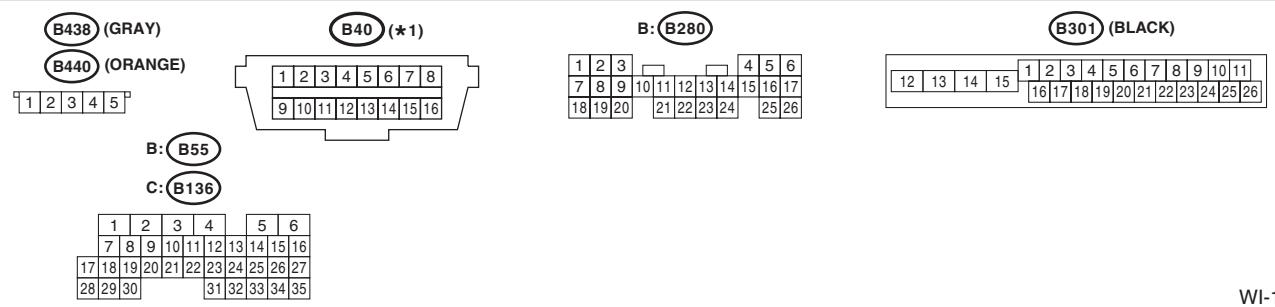
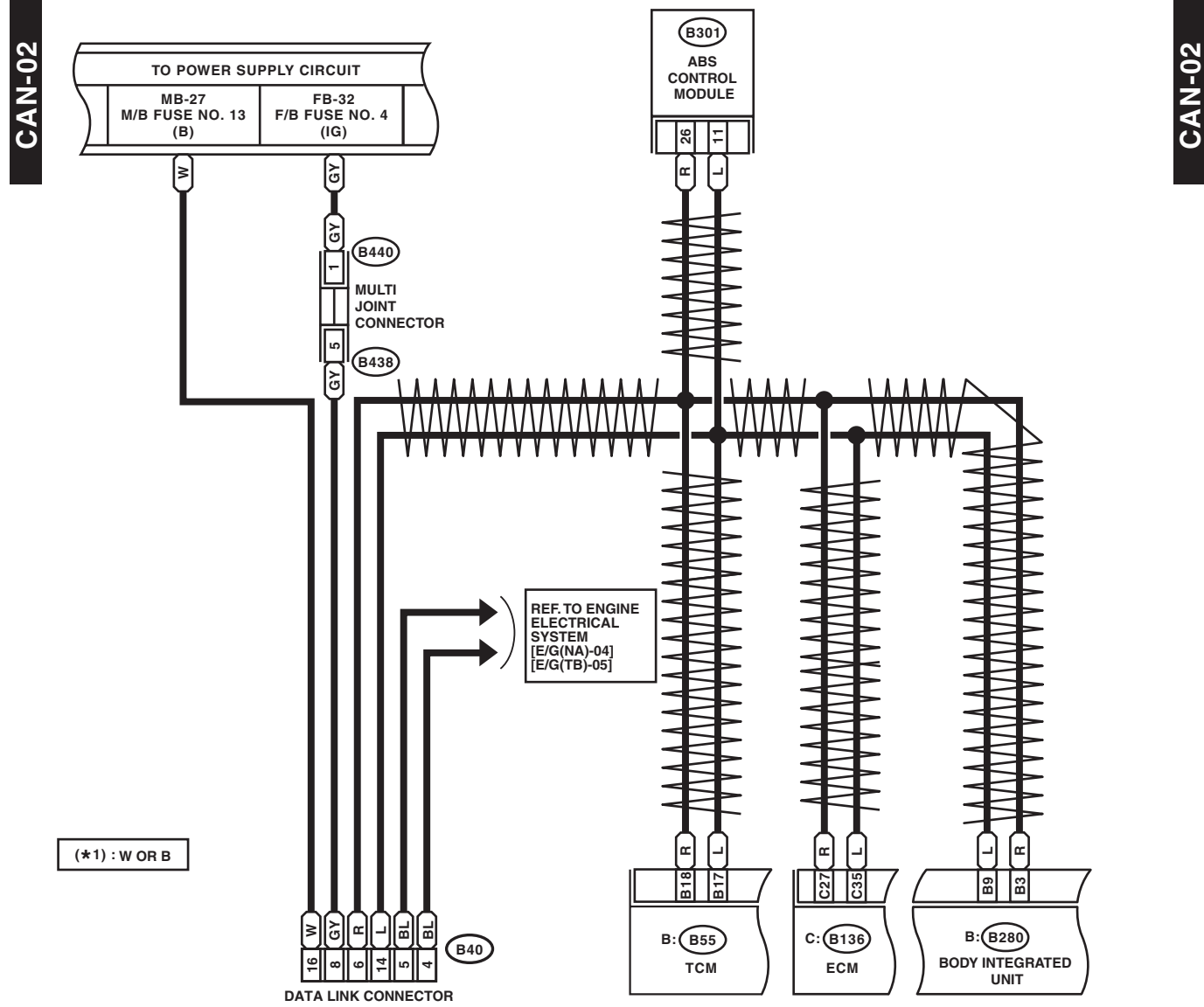

WI-18771

# CAN Communication System

Brought to you by Eris Studios  
NOT FOR RESALE

## WIRING SYSTEM

- Models with VDC

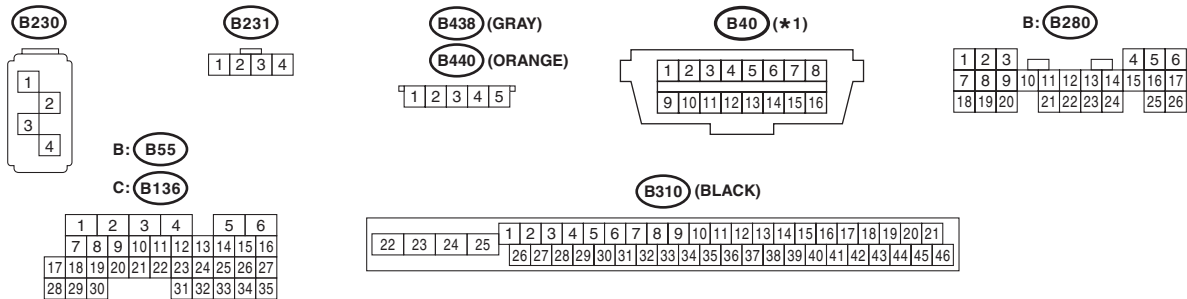
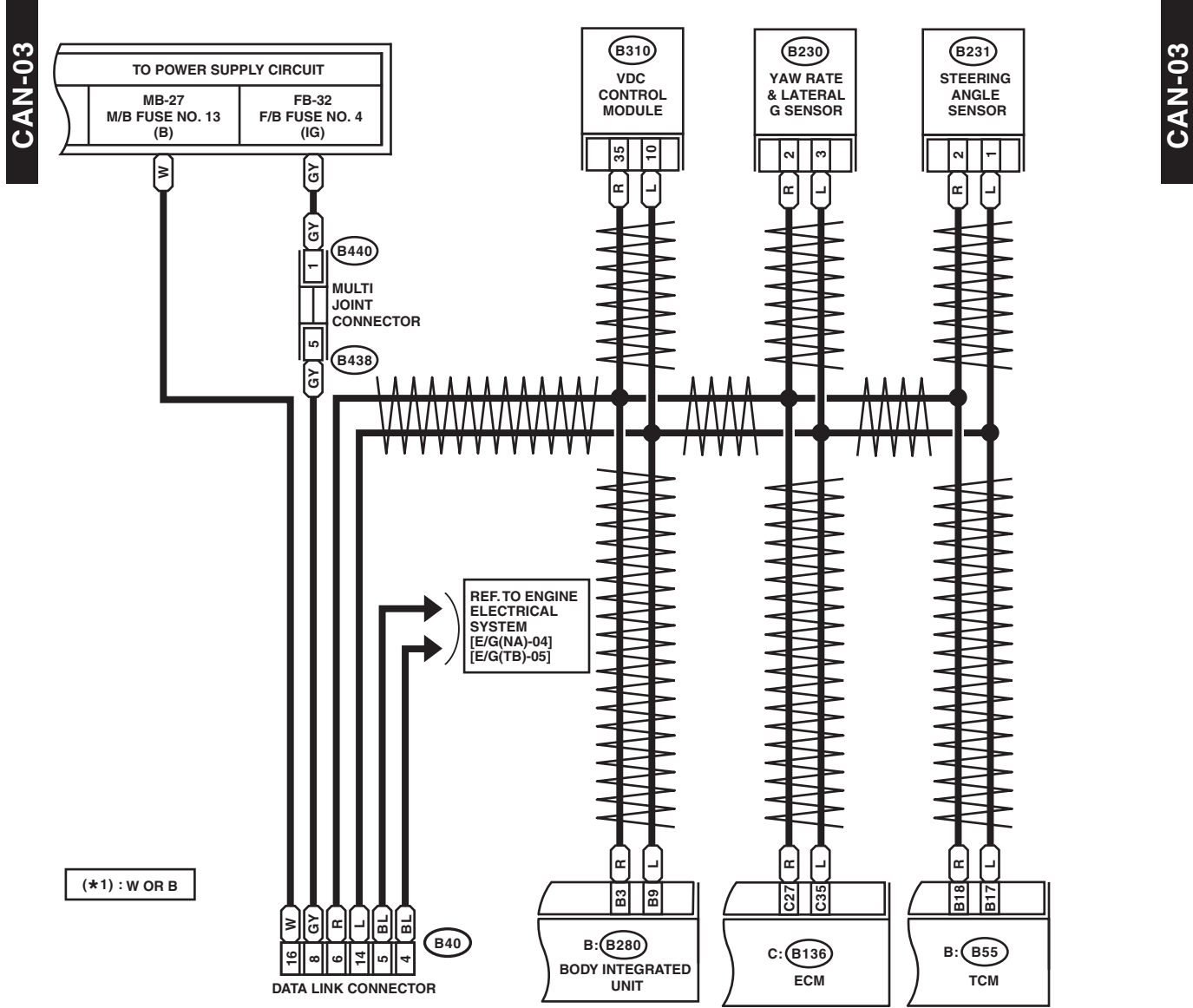

WI-18772

## 50. Compass Mirror System

### A: WIRING DIAGRAM

#### 1. TRANSMISSION SERIAL NO. 4078112 OR EARLIER

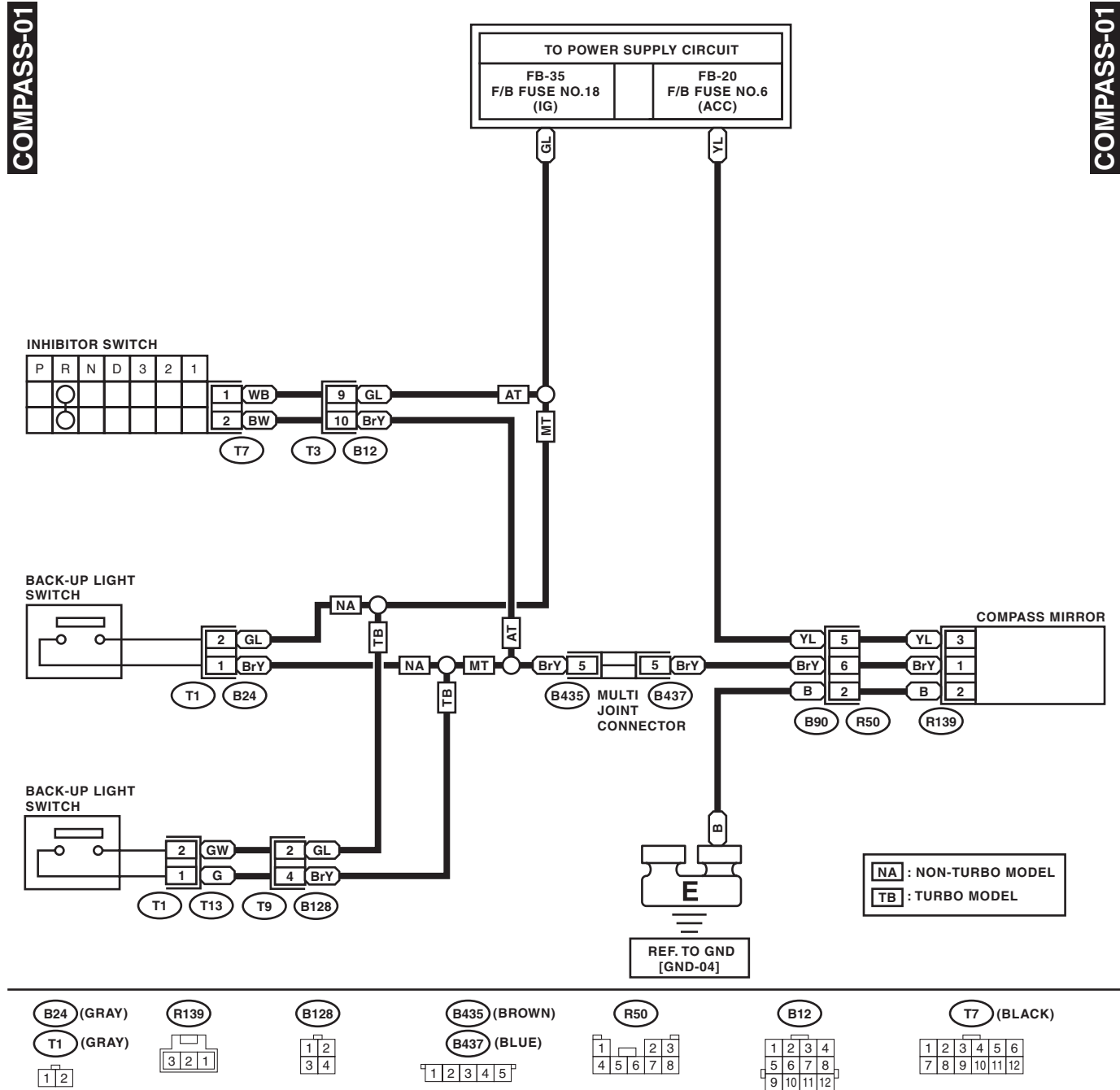

# Compass Mirror System

Brought to you by Eris Studios  
NOT FOR RESALE

## WIRING SYSTEM

### 2. TRANSMISSION SERIAL NO. 4078113 OR LATER

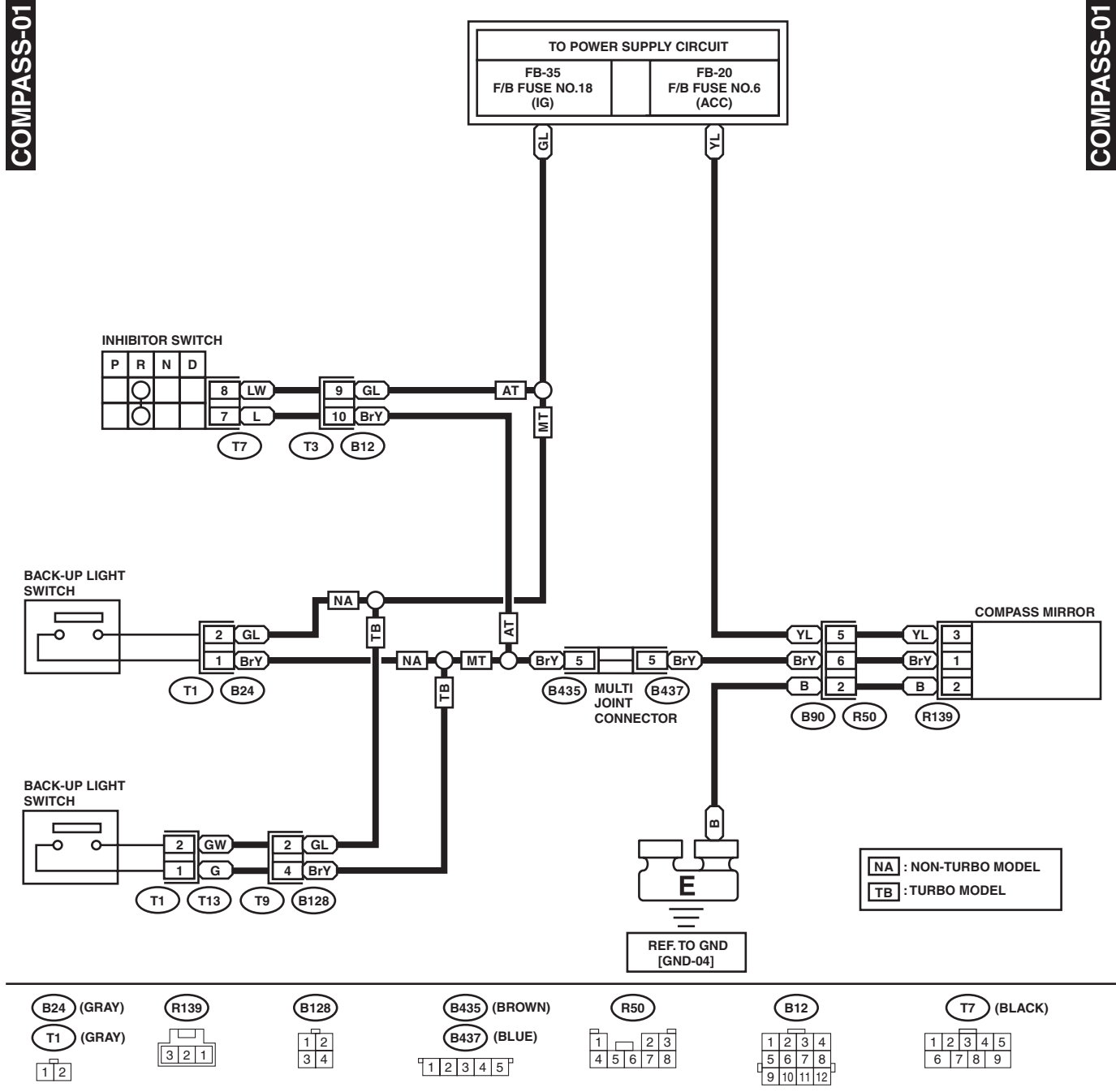

WI-21049

Brought to you by  
 NOT FOR SALE  
 Chris Studios

## 51. Harness Components Location

### A: LOCATION

#### 1. SEDAN MODEL

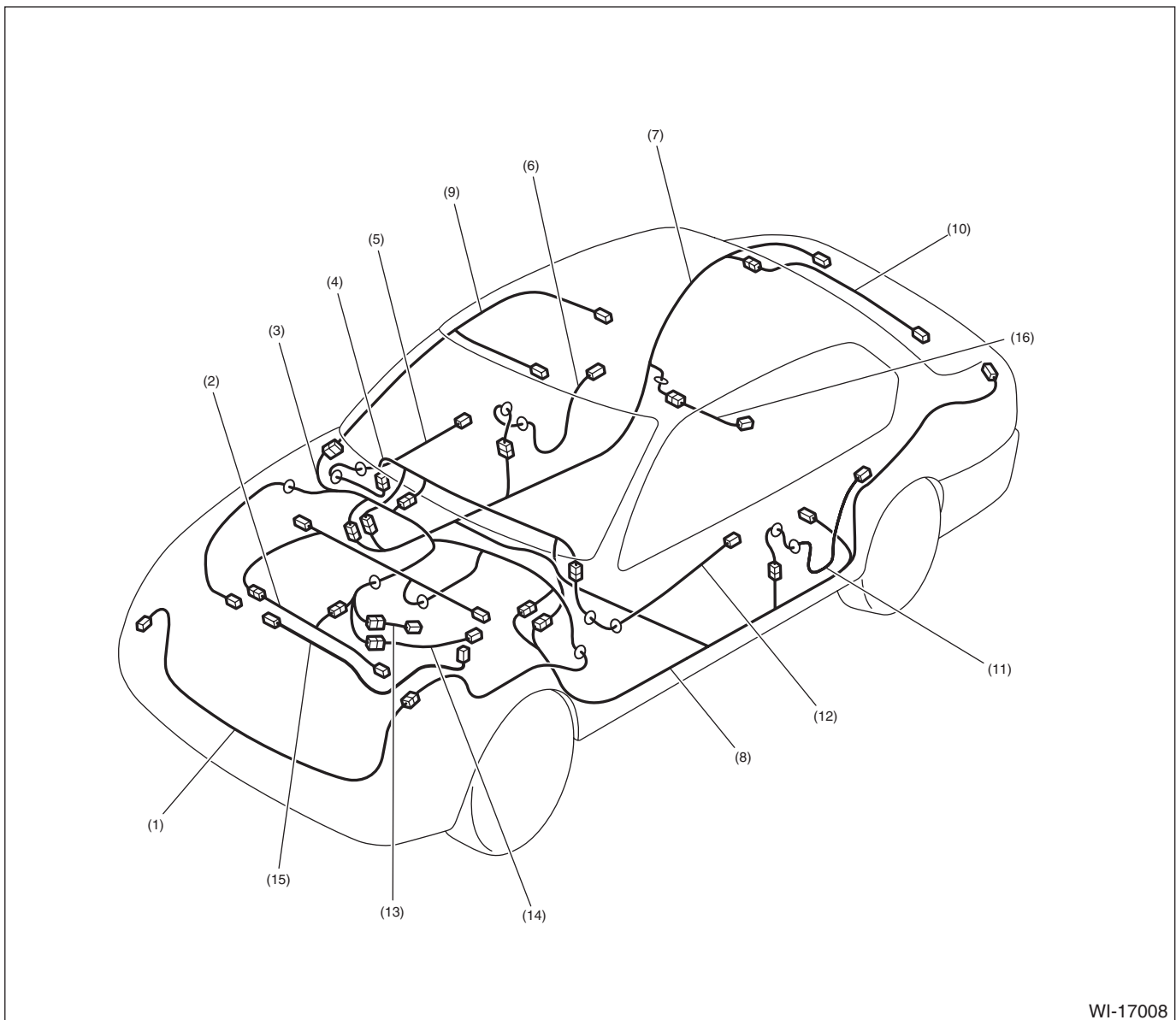

WI-17008

- |                                     |                            |                              |
|-------------------------------------|----------------------------|------------------------------|
| (1) Front wiring harness            | (7) Rear wiring harness RH | (12) Front door cord LH      |
| (2) Engine wiring harness           | (8) Rear wiring harness LH | (13) Transmission cord       |
| (3) Bulkhead wiring harness         | (9) Roof cord              | (14) Rear oxygen sensor cord |
| (4) Instrument panel wiring harness | (10) Trunk lid cord        | (15) Generator cord          |
| (5) Front door cord RH              | (11) Rear door cord LH     | (16) Fuel cord               |
| (6) Rear door cord RH               |                            |                              |

# Harness Components Location

## WIRING SYSTEM

Brought to you by Eris Studios  
NOT FOR RESALE

### 2. WAGON MODEL

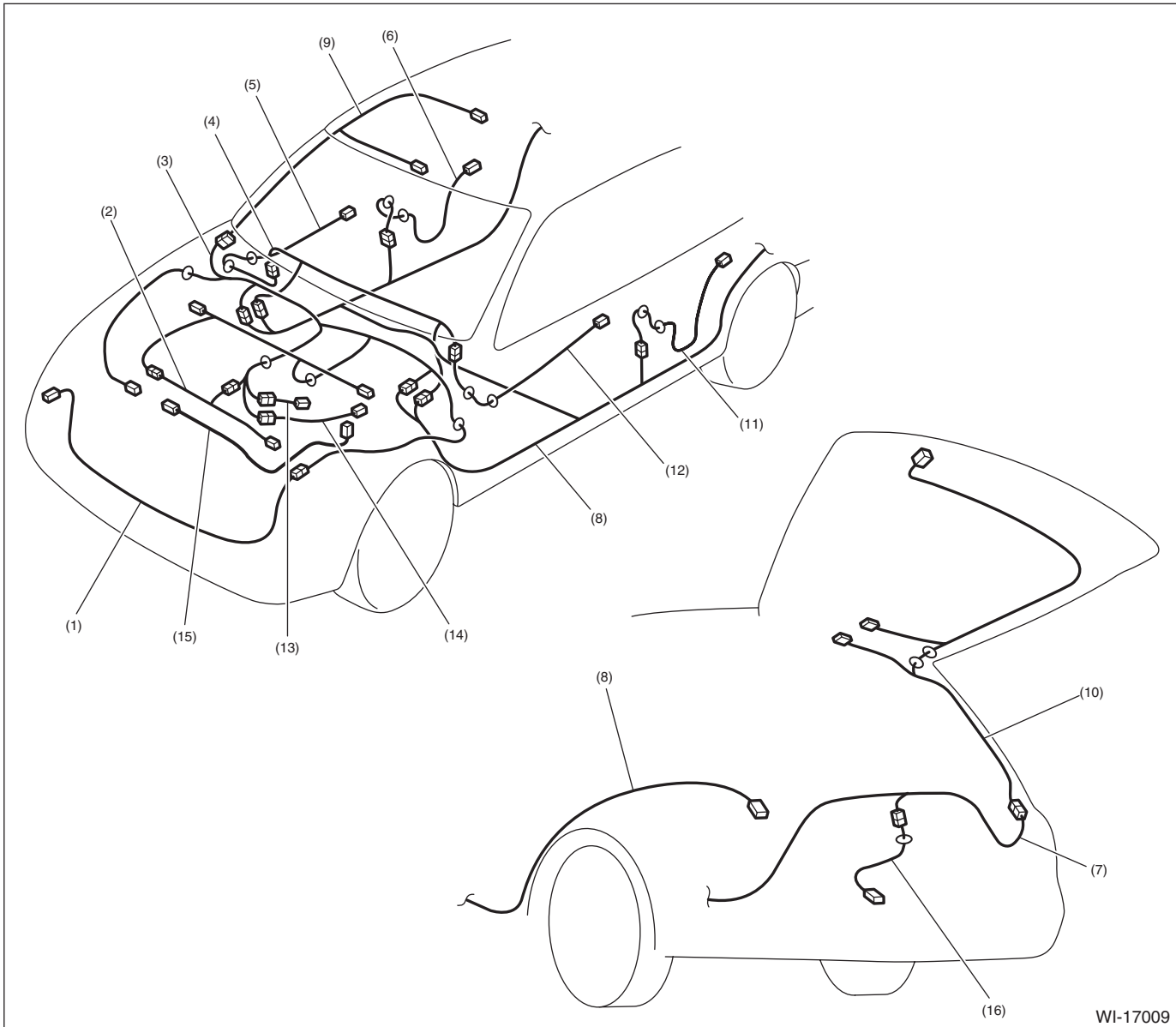

- |                                     |                            |                              |
|-------------------------------------|----------------------------|------------------------------|
| (1) Front wiring harness            | (7) Rear wiring harness RH | (12) Front door cord LH      |
| (2) Engine wiring harness           | (8) Rear wiring harness LH | (13) Transmission cord       |
| (3) Bulkhead wiring harness         | (9) Roof cord              | (14) Rear oxygen sensor cord |
| (4) Instrument panel wiring harness | (10) Rear gate cord        | (15) Generator cord          |
| (5) Front door cord RH              | (11) Rear door cord LH     | (16) Fuel cord               |
| (6) Rear door cord RH               |                            |                              |



Brought to you by *Chris Studios*  
NOT FOR SALE

## 52. Front Wiring Harness

### A: LOCATION

Connector				Connecting to	
No.	Pole	Color	Area	No.	Description
F5	1	Black	C-2		Horn
F6	2	★	C-1		Front fog light RH
F9	16	★	B-5		Secondary air relay holder
F11	2	★	C-3		Secondary air pump
F16	2	★	C-1		Sub fan motor
F17	2	★	C-2		Main fan motor
F21	2	★	D-3		Front fog light LH
F24	1	★	C-2		Magnet clutch
F25	1	★	C-2		Generator terminal B
F26	3	★	C-2		Generator
F27	22	★	B-4		Relay holder
F35	12	Blue	B-4		Main fuse box (M/B)
F36	7	★	B-4		
F37	20	★	C-4		
F47	1	Black	C-2		Horn
F70	2	★	B-4		Main fuse box (M/B)
F78	2	★	C-2		Ambient sensor
F103	2	★	B-1		Daytime running light resistor
F108	18	★	B-4	B361	Through joint connector
F109	24	★	B-3	B360	
F125	8	★	C-3		Headlight & front clearance light LH
F126	8	★	C-1		Headlight & front clearance light RH

★ : White or natural color

# Front Wiring Harness

WIRING SYSTEM

Brought to you by Eris Studios  
NOT FOR RESALE

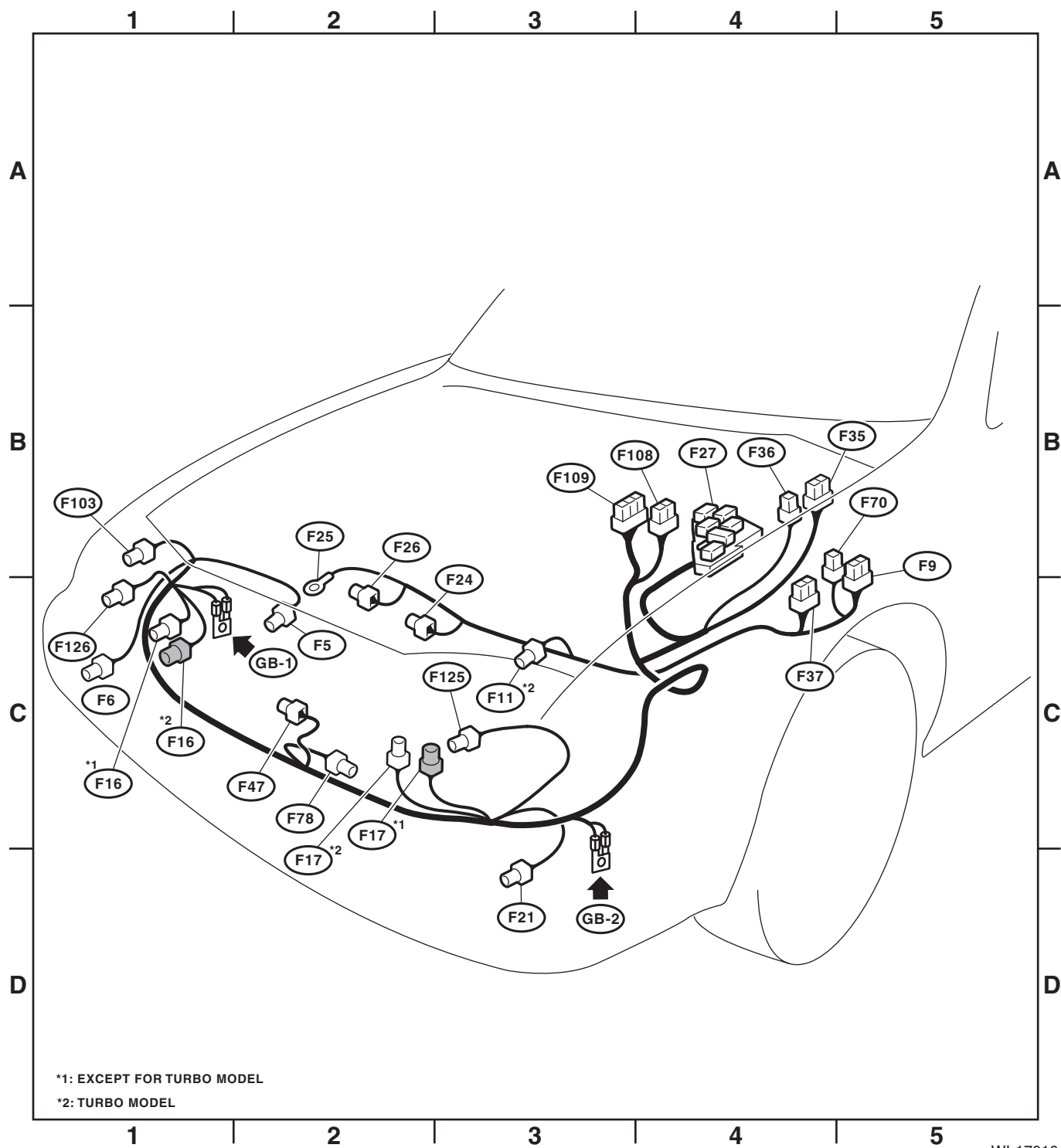

\*1: EXCEPT FOR TURBO MODEL

\*2: TURBO MODEL

WI-17010

# Bulkhead Wiring Harness (In Engine Compartment)

Brought to you by  
 NOT FOR SALE  
 WIRING SYSTEM

## 53. Bulkhead Wiring Harness (In Engine Compartment)

### A: LOCATION

#### 1. NON-TURBO MODEL

Connector				Connecting to	
No.	Pole	Color	Area	No.	Description
B3	5	★	B-2		Mass air flow and intake air temperature sensor
B6	2	Gray	B-2		Front ABS wheel speed sensor RH
B8	5	★	B-3		Front wiper motor
B10	4	★	B-4		Pressure switch
B11	20	Gray	B-3	T4	Transmission cord (AT model)
B12	12	★	B-3	T3	
B14	1	Black	B-4		Starter motor (Magnet)
B15	2	Gray	B-4		Front ABS wheel speed sensor LH
B16	2	Gray	B-3		Brake fluid level switch
B21	54	★	B-3	E2	Engine wiring harness
B24	2	Gray	B-3	T1	Back-up light switch (MT model)
B25	2	Brown	B-4	T2	Neutral position switch
B143	20	★	B-4		Main fuse box (M/B)
B144	9	Brown	B-4		
B145	7	Brown	B-4		
B146	2	★	C-4		Front washer motor
B147	2	★	C-4		Rear washer motor
B164	2	Black	C-3		Keyless buzzer
B186	8	★	B-4		Main fuse box (M/B)
B301	26	Black	B-2		ABS control module
B310	46	Black	B-2		VDC control module
B321	2	★	B-1		Hood switch
B360	16	Gray	B-4	F109	Through joint connector
B361	14	★	B-4	F108	

★ : White or natural color

Connector				Connecting to	
No.	Pole	Color	Area	No.	Description
AB13	2	Yellow	C-3		Front sub sensor LH
AB16	2	Yellow	B-1		Front sub sensor RH

# Bulkhead Wiring Harness (In Engine Compartment)

WIRING SYSTEM

Brought to you by Eris Studios  
NOT FOR RESALE

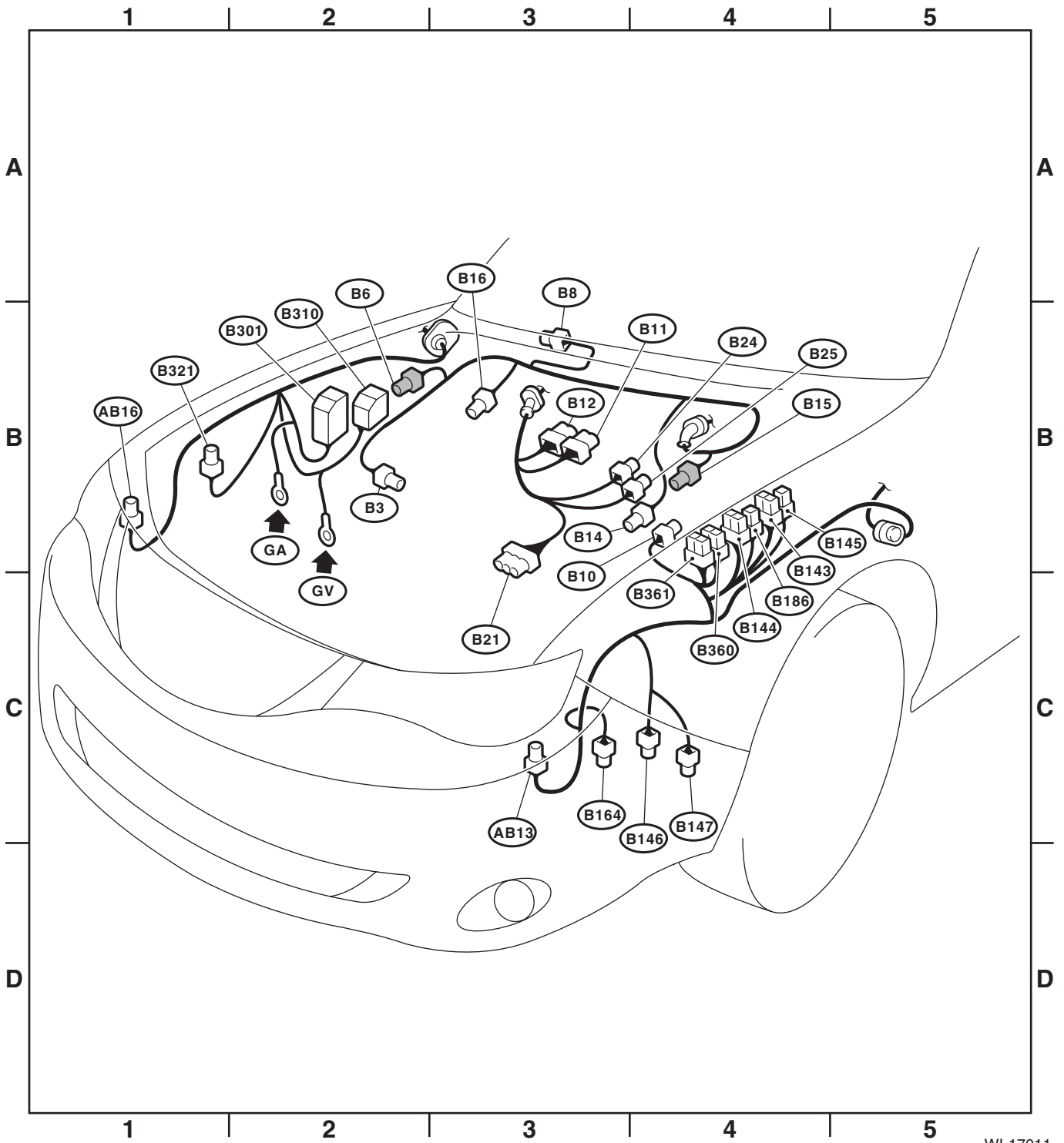

WI-17011

# Bulkhead Wiring Harness (In Engine Compartment)

WIRING SYSTEM

Brought to you by  
NOT FOR SALE  
Chris Studios

## 2. TURBO MODEL

Connector				Connecting to	
No.	Pole	Color	Area	No.	Description
B3	5	★	B-2		Mass air flow and intake air temperature sensor
B6	2	Gray	B-2		Front ABS wheel speed sensor RH
B8	5	★	B-3		Front wiper motor
B10	4	★	B-4		Pressure switch
B11	20	Gray	B-3	T4	Transmission cord (AT model)
B12	12	★	B-3	T3	
B14	1	Black	B-3		Starter motor (Magnet)
B15	2	Gray	B-4		Front ABS wheel speed sensor LH
B16	2	Gray	B-3		Brake fluid level switch
B19	4	★	B-3	T5	Rear oxygen sensor cord
B21	54	★	B-3	E2	Engine wiring harness
B128	4	★	B-3	T9	Transmission cord (MT model)
B143	20	★	B-4		Main fuse box (M/B)
B144	9	Brown	B-4		
B145	7	Brown	B-4		
B146	2	★	C-4		Front washer motor
B147	2	★	C-4		Rear washer motor
B164	2	Black	C-3		Keyless buzzer
B186	8	★	B-4		Main fuse box (M/B)
B301	26	Black	B-2		ABS control module
B310	46	Black	B-2		VDC control module
B321	2	★	B-1		Hood switch
B360	16	Gray	B-4	F109	Through joint connector
B361	14	★	B-4	F108	
B379	4	★	B-3		Front oxygen (A/F) sensor

★ : White or natural color

Connector				Connecting to	
No.	Pole	Color	Area	No.	Description
AB13	2	Yellow	C-3		Front sub sensor LH
AB16	2	Yellow	B-1		Front sub sensor RH

# Bulkhead Wiring Harness (In Engine Compartment)

Brought to you by Eris Studios  
NOT FOR RESALE

## WIRING SYSTEM

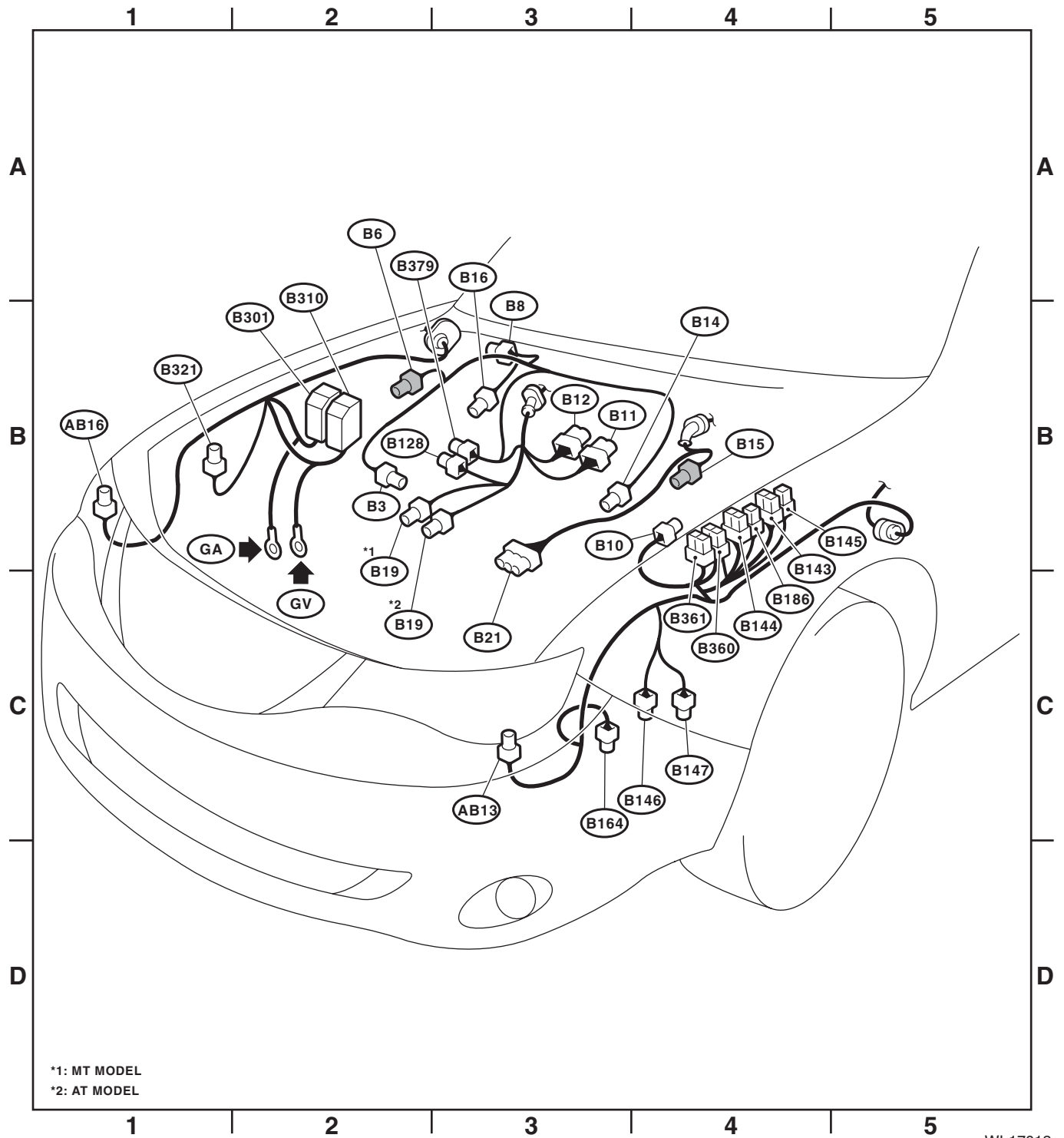

WI-17012

# Bulkhead Wiring Harness (In Compartment)

Brought to you by  
 NOT FOR SALE  
 WIRING SYSTEM  
 Chris Studios

## 54. Bulkhead Wiring Harness (In Compartment)

### A: LOCATION

Connector				Connecting to	
No.	Pole	Color	Area	No.	Description
B27	4	★	B-3		Blower Resistor (Manual A/C)
B31	6	★	B-1	AB1	Airbag wiring harness
B32	8	★	C-2		Turn signal and hazard unit
B36	28	★	B-4	i1	Instrument panel wiring harness
B38	28	★	B-2	i3	
B40	16	★ or Black	C-2		Data link connector
B41	2	★	B-2		Power window circuit breaker
B52	24	★	B-2		Fuse & relay box (F/B)
B53	20	★	C-3		Joint connector
B54	35	★	C-3		TCM
B55	35	★	C-3		
B57	4	★	B-3		Power transistor
B65	4	Black	C-2		Stop light & brake switch (Sedan model)
		★	C-2		Stop light & brake switch (Wagon model)
B68	14	★	C-2		Roll connector
B70	18	★	C-2		Combination switch
B71	17	★	C-2		
B72	6	★	C-2		Ignition switch
B75	2	Green	B-4	B76	Delivery (test) mode connector
B76	2	Green	B-4	B75	
B77	6	★	B-3		Mode door actuator (Auto A/C)
B83	8	★	C-4		Joint connector
B87	2	★	B-4		Blower motor
B88	2	Brown	B-3		Evaporator sensor (Auto A/C)
	3	★	B-3		Evaporator sensor (Manual A/C)
B89	2	Black	B-5		Blower diode
B90	8	★	B-5	R50	Roof cord
B97	12	★	C-5	R1	Rear wiring harness
B98	20	★	C-5	R2	
B99	12	★	C-1	R3	
B106	2	★	C-2		Clutch switch
B107	2	Blue	C-2		Clutch switch (model with cruise control)
B117	10	Gray	C-4		AT select lever
B122	8	★	C-4		Joint connector
B123	2	★	C-1	B124	Key lock
B124	2	★	C-1	B123	
B134	34	★	C-4		ECM
B135	35	★	C-4		
B136	35	★	C-4		
B137	31	★	C-4		
B138	8	★	C-4		Joint connector
B152	10	Gray	B-2		Fuse & relay box (F/B)
B158	8	★	B-2		
B159	9	Brown	B-2		
B162	2	★	B-2		

# Bulkhead Wiring Harness (In Compartment)

Brought to you by Eris Studios  
NOT FOR RESALE

## WIRING SYSTEM

Connector				Connecting to	
No.	Pole	Color	Area	No.	Description
B163	6	★	C-4		Intake door actuator
B177	2	★	B-5		Wiper deicer
B180	24	★	B-2		Remote engine start control module
B181	2	★	B-2	B182	Short connector
B182	2	★	C-2	B181	
B220	40	★	B-4		Fuse (Relay block)
					A/F, oxygen sensor relay
					Fuel pump relay
					IG relay
					Main relay
					Electronic throttle control relay
B224	2	★	C-2		Key illumination
B225	40	★	C-2		Fuse (Relay block)
					Starter relay
					Front fog light relay
					Power window relay
					Wiper deicer relay
					Tail and illumination relay
					Seat heater relay
B230	4	★	D-4		Yaw rate & lateral G sensor (with VDC)
B231	4	★	C-2		Steering angle sensor (with VDC)
B239	6	★	C-3		Air mix door actuator (Auto A/C)
B279	30	★	B-3		Body integrated unit
B280	26	★	B-3		
B281	28	★	B-3		
B292	3	★	D-4		
B315	6	★	C-3		Accelerator pedal position sensor
B318	4	★	B-1		VDC OFF switch
B350	4	★	C-2		Key warning switch & key lock solenoid
B358	2	★	C-4		AT select lever illumination
B363	2	Green	C-1	B364	Test mode sub connector
B364	2	Green	C-1	B363	
B367	8	★	C-2		Impact sensor
B386	7	★	B-4		Blower motor relay
B415	2	Black	B-2		Immobilizer antenna
B434	5	Pink	D-1		Multi joint connector
B435	5	Brown	D-1		
B436	5	Yellow	D-1		
B437	5	Blue	D-1		
B438	5	Gray	D-1		
B439	5	Green	D-1		
B440	5	Orange	D-1		
B441	5	★	D-1		
B442	5	Black	D-2		
B443	5	Red	D-2		
B444	5	Light green	D-2		
B445	5	Violet	D-2		

★ : White or natural color



# Bulkhead Wiring Harness (In Compartment)

WIRING SYSTEM

Brought to you by *Chris Studios*  
NOT FOR SALE

Connector				Connecting to	
No.	Pole	Color	Area	No.	Description
AB1	6	Yellow	B-1	B31	Bulkhead wiring harness
AB2	4	Yellow	C-2	AB7	Driver's airbag module
AB6	30	Yellow	C-4		Airbag control module
AB9	4	Yellow	C-4		Passenger's airbag module

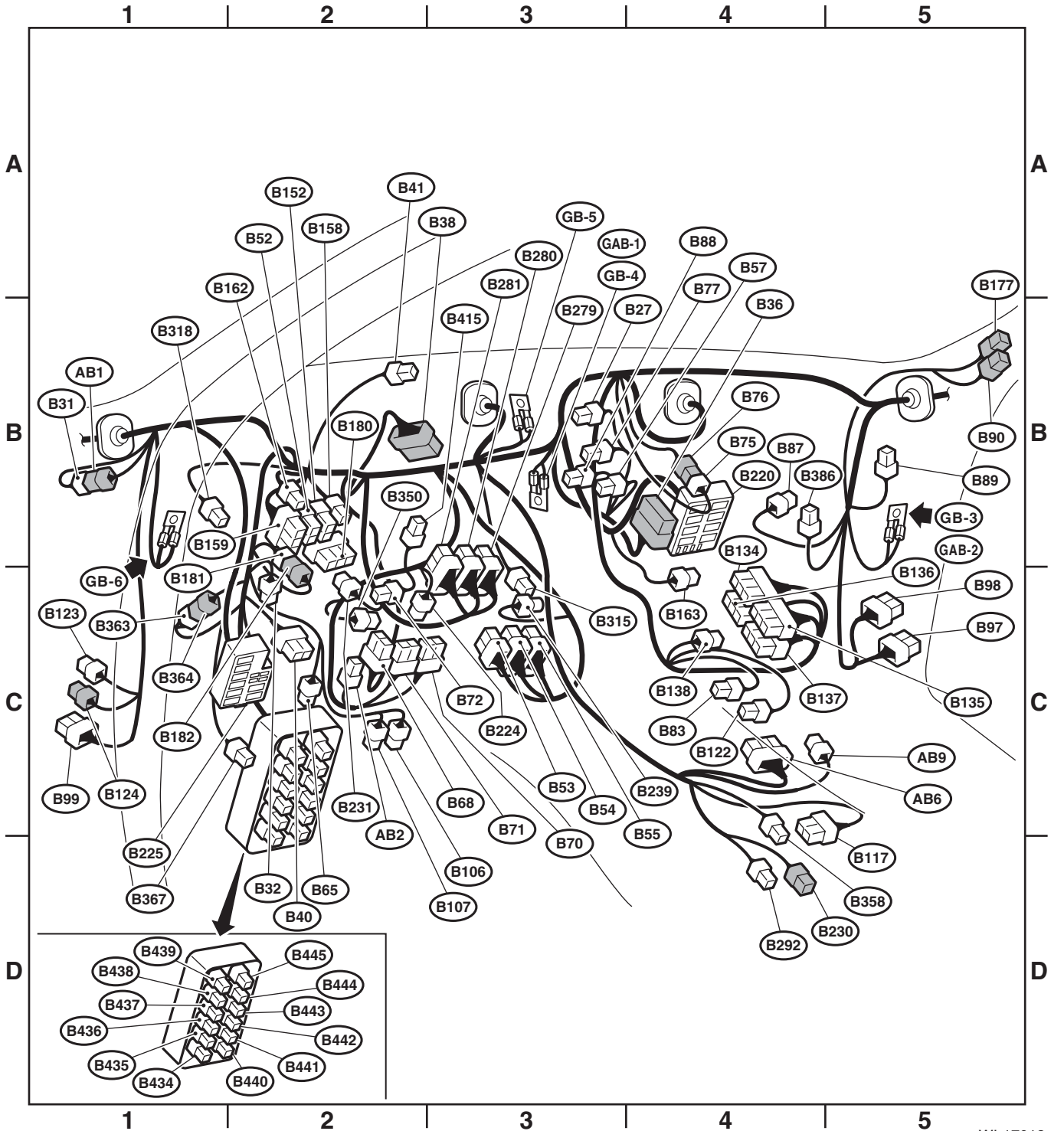

WI-17013

# Engine Wiring Harness and Transmission Cord

WIRING SYSTEM

Brought to you by Eris Studios  
NOT FOR RESALE

## 55.Engine Wiring Harness and Transmission Cord

### A: LOCATION

#### 1. NON-TURBO MODEL

Connector				Connecting to	
No.	Pole	Color	Area	No.	Description
E2	54	Black	A-3	B21	Bulkhead wiring harness
E4	2	Black	B-3		Purge control solenoid valve
E5	2	Dark gray	B-1		Fuel injector No. 1
E6	2	Dark gray	A-2		Fuel injector No. 3
E8	2	Black	B-2		Engine coolant temperature sensor
E10	2	Light gray	B-3		Crankshaft position sensor
E11	1	—	B-2		Oil pressure switch
E12	4	Dark gray	A-2		Ignition coil & ignitor assembly
E14	2	Gray	B-4		Knock sensor
E15	2	Black	B-4		Camshaft position sensor
E16	2	Dark gray	B-4		Fuel injector No. 2
E17	2	Dark gray	B-4		Fuel injector No. 4
E18	6	Dark gray	A-4		EGR valve
E19	1	★	B-2		Power steering oil pressure switch
E21	3	Black	A-4		Manifold absolute pressure sensor
E22	6	Black	A-1		Front oxygen (A/F) sensor
E23	4	Dark gray	A-1		Rear oxygen sensor
E57	6	Black	A-3		Electronic throttle control
E61	2	Dark gray	A-3		PCV diagnosis connector
E67	2	Blue	A-2		Oil switching solenoid valve RH
E68	2	Blue	B-4		Oil switching solenoid valve LH
E71	1	Gray	A-2		Variable valve lift diagnosis oil pressure switch RH
E72	1	Gray	B-4		Variable valve lift diagnosis oil pressure switch LH
E75	2	Black	B-2		Oil temperature sensor

★ : White or natural color

#### • MT model

Connector				Connecting to	
No.	Pole	Color	Area	No.	Description
T1	2	Gray	D-2	B24	Bulkhead wiring harness
T2	2	Brown	D-2	B25	

#### • AT model

Connector				Connecting to	
No.	Pole	Color	Area	No.	Description
T3	12	Black	D-4	B12	Bulkhead wiring harness
T4	20	Gray	D-4	B11	
T7	12	Black	D-5		Inhibitor switch (transmission serial No. 4078112 or earlier)
	9	Black	D-5		Inhibitor switch (transmission serial No. 4078113 or later)

# Engine Wiring Harness and Transmission Cord

WIRING SYSTEM

Brought to you by *Chris Studios*  
NOT FOR SALE

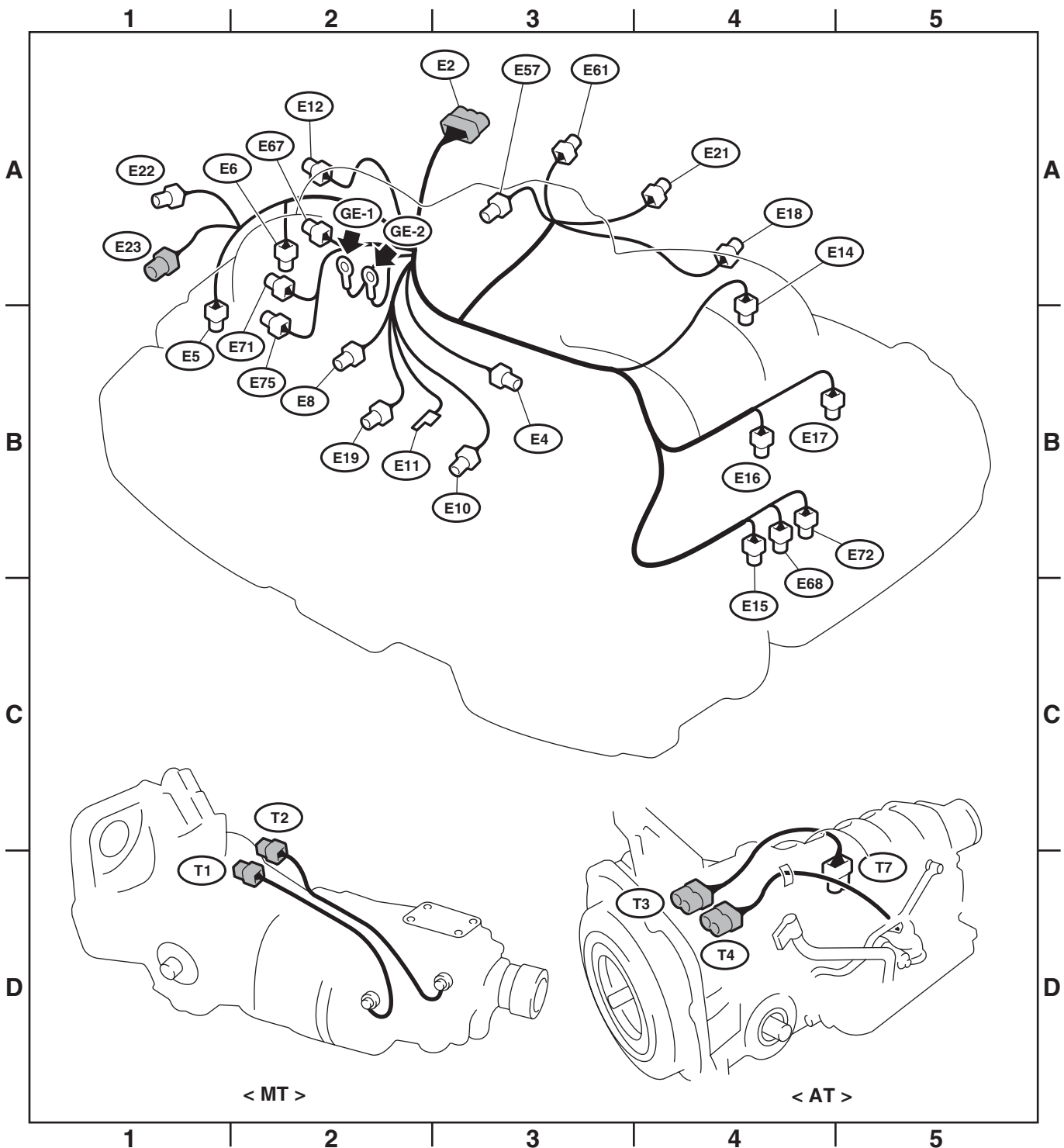

WI-17014

# Engine Wiring Harness and Transmission Cord

## WIRING SYSTEM

Brought to you by Eris Studios  
NOT FOR RESALE

### 2. TURBO MODEL

Connector				Connecting to	
No.	Pole	Color	Area	No.	Description
E2	54	Black	A-2	B21	Bulkhead wiring harness
E4	2	Black	B-2		Purge control solenoid valve 1
E5	2	Dark gray	A-1		Fuel injector No. 1
E6	2	Dark gray	A-2		Fuel injector No. 3
E8	2	Black	B-2		Engine coolant temperature sensor
E10	2	Light gray	B-3		Crankshaft position sensor
E11	1	—	B-2		Oil pressure switch
E14	2	Light gray	A-3		Knock sensor
E16	2	Dark gray	B-4		Fuel injector No. 2
E17	2	Dark gray	B-4		Fuel injector No. 4
E19	1	★	B-2		Power steering oil pressure switch
E21	3	Black	A-3		Manifold absolute pressure sensor
E31	3	★	B-2		Ignition coil No. 1
E32	3	★	B-4		Ignition coil No. 2
E33	3	Black	A-2		Ignition coil No. 3
E34	3	Black	B-4		Ignition coil No. 4
E35	3	Light gray	A-4		Camshaft position sensor LH
E36	3	Light gray	A-2		Camshaft position sensor RH
E37	2	Blue	B-4		Oil flow control solenoid valve LH
E38	2	Blue	B-1		Oil flow control solenoid valve RH
E40	2	Black	B-4		Secondary air combination valve LH
E41	6	Black	B-2		Secondary air combination valve RH
E51	5	Light gray	B-4		Tumble generator valve ASSY LH
E52	2	Black	A-3		Purge control solenoid valve 2
E55	5	Light gray	A-1		Tumble generator valve ASSY RH
E57	6	Black	A-3		Electronic throttle control
E64	2	Blue	A-3		Wastegate control solenoid valve
E80	2	Dark gray	B-2		Leak diagnosis connector

★ : White or natural color

#### • MT model

Connector				Connecting to	
No.	Pole	Color	Area	No.	Description
T1	2	Gray	D-2	T13	Transmission cord
T2	2	Brown	D-2	T12	
T5	4	Green	C-1	B19	Bulkhead wiring harness
T6	4	Dark gray	D-2		Rear oxygen sensor
T9	4	Gray	C-1	B128	Bulkhead wiring harness
T12	2	Brown	D-2	T2	Neutral position switch
T13	2	Gray	D-2	T1	Back-up light switch

# Engine Wiring Harness and Transmission Cord

WIRING SYSTEM

Brought to you by  
 NOT FOR SALE  
 Chris Studios

• **AT model**

Connector				Connecting to	
No.	Pole	Color	Area	No.	Description
T3	8	Black	D-4	B12	Bulkhead wiring harness
T4	20	Gray	D-4	B11	
T5	4	Green	C-3	B19	
T6	4	Dark gray	D-5		Rear oxygen sensor
T7	12	Black	C-5		Inhibitor switch (transmission serial No. 4078112 or earlier)
	9	Black	C-5		Inhibitor switch (transmission serial No. 4078113 or later)

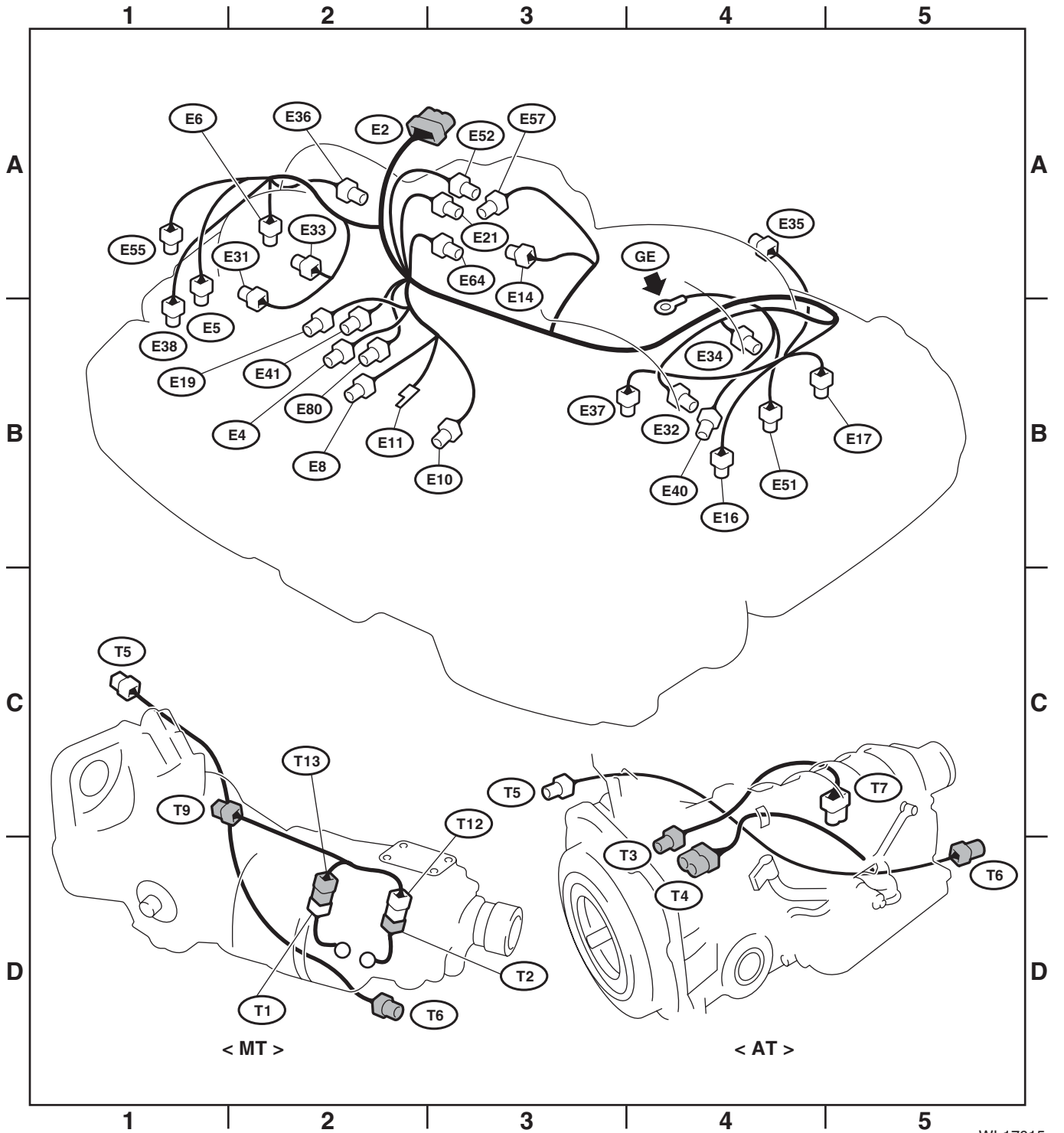

WI-17015

# Instrument Panel Wiring Harness

WIRING SYSTEM

Brought to you by Eris Studios  
NOT FOR RESALE

## 56. Instrument Panel Wiring Harness

### A: LOCATION

Connector				Connecting to	
No.	Pole	Color	Area	No.	Description
i1	28	★	B-5	B36	Bulkhead wiring harness
i3	28	★	C-1	B38	
i5	20	★	C-2		Fuse & relay box (F/B)
i6	10	★	C-2		Remote control mirror switch
i10	40	★	B-2		Combination meter
i15	6	★	C-4		Blower fan switch (Manual A/C)
i16	12	★	C-4		A/C control panel (Manual A/C)
i22	4	★	B-3		Hazard switch
i23	2	★	B-5		Glove box light
i24	4	★	C-4	AD1	Front accessory power supply socket
i29	1	★	C-4		Audio bracket earth
i50	24	★	C-4		Navigation unit
i51	2	★	B-4		Sunload sensor
i53	16	★	C-5	R98	Rear wiring harness RH
i54	10	★	C-5	R99	Rear wiring harness RH
i55	2	★	C-3		In-vehicle sensor
i59	10	★	C-3		Clock
i76	28	★	C-1	D83	Front door cord LH
i77	10	★	B-2		CAN joint connector
i79	6	★	C-2		Illumination control unit
i84	35	★	B-1		Body integrated unit
i85	20	★	C-4		Audio (without navigation system)
i86	8	Black	C-4		Audio (without navigation system, with AUX)
i87	14	★	C-4		Audio (with navigation system)
i88	40	★	B-4		A/C control pane (Auto A/C)
i97	8	★	C-1		Joint ground connector
i98	8	★	C-1		
i99	8	★	B-5		
i100	8	★	B-5		
i101	25	★	C-5	D84	Front door cord RH
i102	16	★	C-1	R167	Rear wiring harness LH

★ White or natural color

# Instrument Panel Wiring Harness

WIRING SYSTEM

Brought to you by  
NOT FOR SALE  
Eris Studios

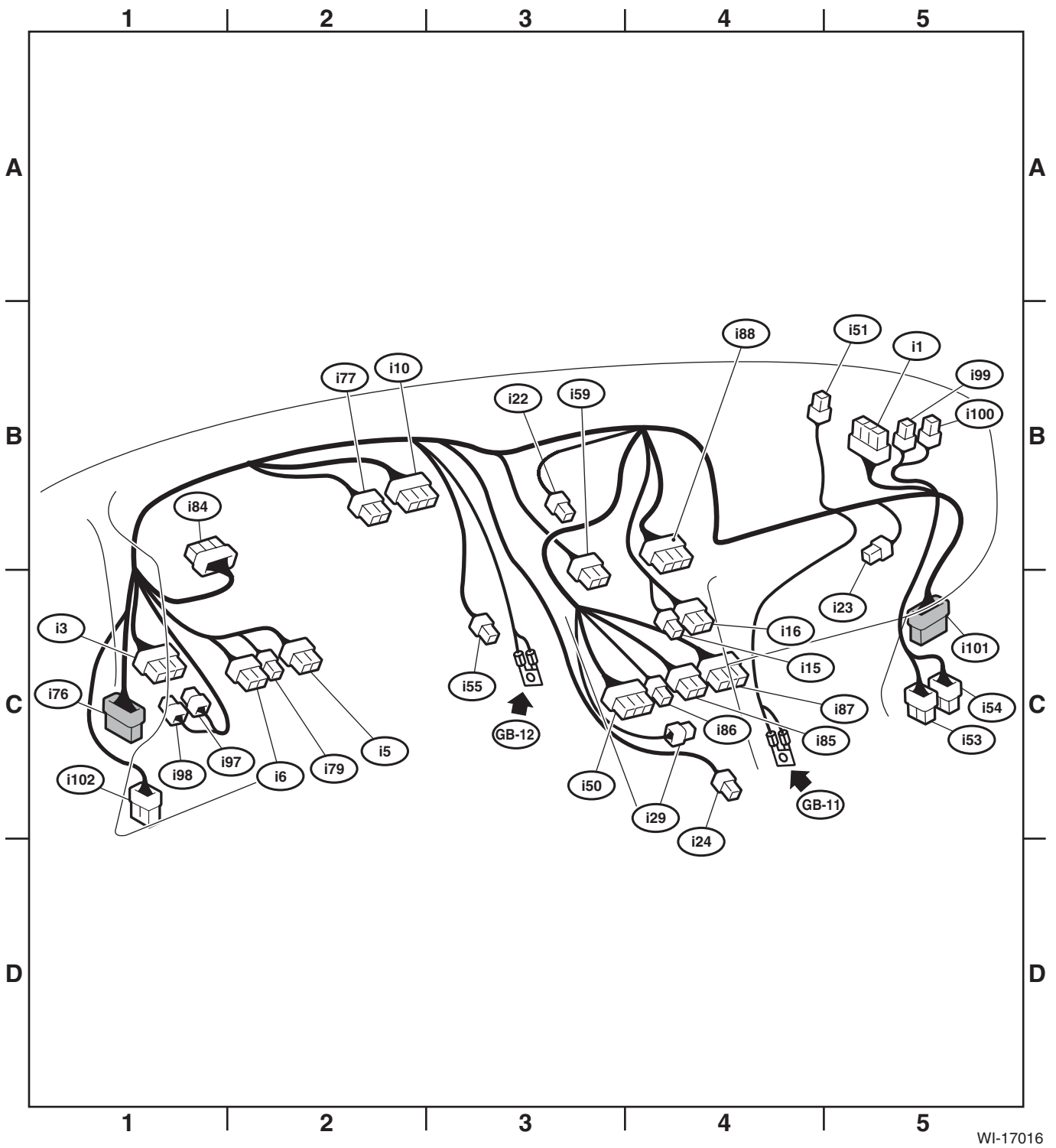

WI-17016

# Rear Wiring Harness

WIRING SYSTEM

Brought to you by Eris Studios  
NOT FOR RESALE

## 57.Rear Wiring Harness

### A: LOCATION

Connector				Connecting to	
No.	Pole	Color	Area	No.	Description
R1	12	★	B-1	B97	Bulkhead wiring harness
R2	20	★	B-1	B98	
R3	12	★	C-3	B99	
R4	1	★	C-3		Parking brake switch
R9	3	★	C-4		Front door switch LH
R10	8	★	C-4	D22	Rear door cord LH
R12	3	★	B-2		Front door switch RH
R13	8	★	B-2	D28	Rear door cord RH
R15	12	★	B-4	R57	Fuel cord
R16	3	★	A-3		Rear door switch RH
R32	2	★	B-3		Rear accessory power supply socket
R41	4	★	C-3		Seat heater LH
R42	4	★	B-3		Seat heater switch RH
R43	4	★	B-3		Seat heater switch LH
R44	4	★	B-3		Seat heater RH
R47	3	Black	B-4		Fuel tank pressure sensor
R50	8	★	B-1	B90	Bulkhead wiring harness
R52	3	★	A-3		Room light
R56	2	★	B-2		Spot map light
R57	12	★	B-4	R15	Rear wiring harness
R58	6	★	B-4		Fuel pump assembly (Fuel pump)
R59	2	★	B-5		Fuel sub level sensor
R68	2	Dark gray	B-4		Pressure control solenoid valve
R72	2	★	B-4		Rear ABS wheel speed sensor RH
R73	2	★	B-4		Rear ABS wheel speed sensor LH
R81	12	★	C-3	R82	Rear wiring harness RH
R82	12	★	B-3	R81	Rear wiring harness LH
R98	16	★	B-1	i53	Instrument panel wiring harness
R99	10	★	B-1	i54	
R107	4	★	C-3		Seat belt switch LH
R139	3	★	B-3		Compass mirror
R167	16	★	C-3	i102	Instrument panel wiring harness
R168	20	★	C-3		Fuse & relay box (F/B)
R211	6	★	B-4		TPM control module
R284	6	★	B-3		AUX input terminal

★ : White or natural color



# Rear Wiring Harness

WIRING SYSTEM

Brought to you by  
 NOT FOR SALE  
 Chris Studios

Connector				Connecting to	
No.	Pole	Color	Area	No.	Description
AB17	24	Yellow	C-2		Airbag control module (with side airbag)
AB18	24	Yellow	C-2		
AB19	4	Yellow	C-3		Side airbag module LH
AB21	2	Black	C-4		Pretensioner LH
AB23	4	Yellow	C-4		Side airbag sensor LH
AB24	4	Yellow	B-2		Side airbag module RH
AB26	2	Black	B-2		Pretensioner RH
AB28	4	Yellow	B-2		Side airbag sensor RH
AB34	4	Black	A-3		Curtain airbag sensor RH
AB35	2	Black	C-3		Fuse & relay box (F/B)
AB41	2	Yellow	B-4		Satellite safing sensor (with side airbag)
AB53	6	Gray	B-2		Occupant detection control module
AB56	3	Brown	B-3		Belt tensioner sensor

# Rear Wiring Harness

WIRING SYSTEM

Brought to you by Eris Studios  
NOT FOR RESALE

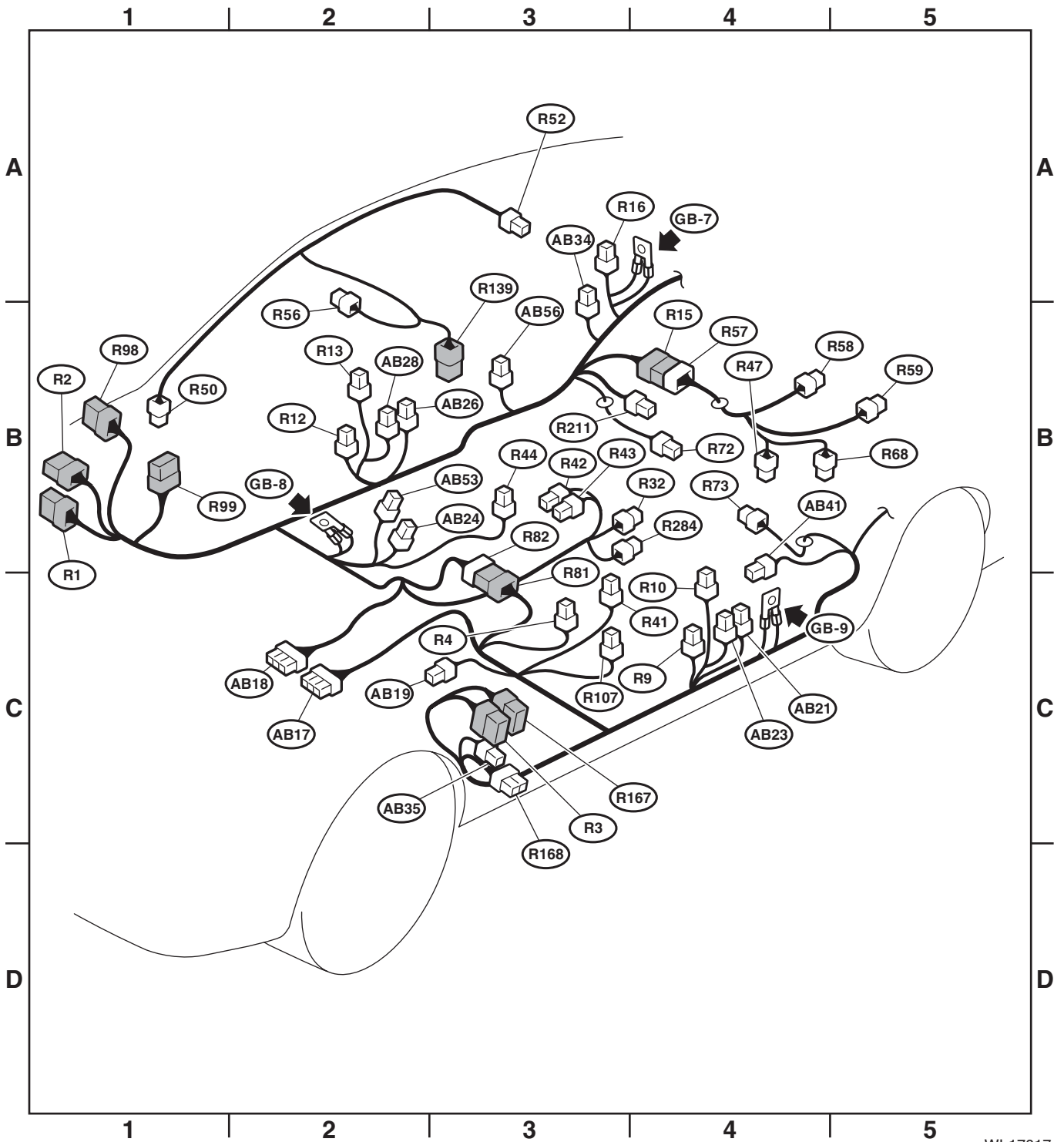

WI-17017

# Door Cord

WIRING SYSTEM

Brought to you by  
Chris Studios  
NOT FOR SALE

## 58. Door Cord

### A: LOCATION

Connector				Connecting to	
No.	Pole	Color	Area	No.	Description
D2	2	★	C-4		Front door speaker LH
D3	6	★	C-4		Front power window motor LH
D4	2	Black	C-3		Front door tweeter LH
D5	8	★	C-3		Outer mirror assembly LH (without mirror heater)
	10	★	C-4		Outer mirror assembly LH (with mirror heater)
D7	16	★	B-4		Power window main switch
D12	2	★	B-2		Front door speaker RH
D13	6	★	B-2		Front power window motor RH
D14	2	Black	B-2		Front door tweeter RH
D15	8	★	B-2		Outer mirror assembly RH (without mirror heater)
	10	★	B-2		Outer mirror assembly RH (with mirror heater)
D17	8	★	B-2		Front power window sub-switch
D18	2	★	B-3		Front door lock actuator RH
D22	8	★	C-4	R10	Rear wiring harness LH
D23	2	★	C-4		Rear door speaker LH
D24	6	★	B-4		Rear power window motor LH
D25	8	★	B-4		Rear power window sub-switch LH
D26	2	★	B-5		Rear door lock actuator LH
D28	8	★	B-3	R13	Rear wiring harness RH
D29	2	★	B-3		Rear door speaker RH
D30	6	★	B-3		Rear power window motor RH
D31	8	★	B-3		Rear power window sub-switch RH
D32	2	★	B-3		Rear door lock actuator RH
D72	2	★	C-4		Front door lock actuator LH
D83	28	★	C-3	i76	Instrument panel wiring harness
D84	25	★	B-2	i101	
D102	3	★	C-4		Power window main switch
D125	5	★	B-2		Passenger's seat door lock switch

★ : White or natural color

# Door Cord

WIRING SYSTEM

Brought to you by Eris Studios  
NOT FOR RESALE

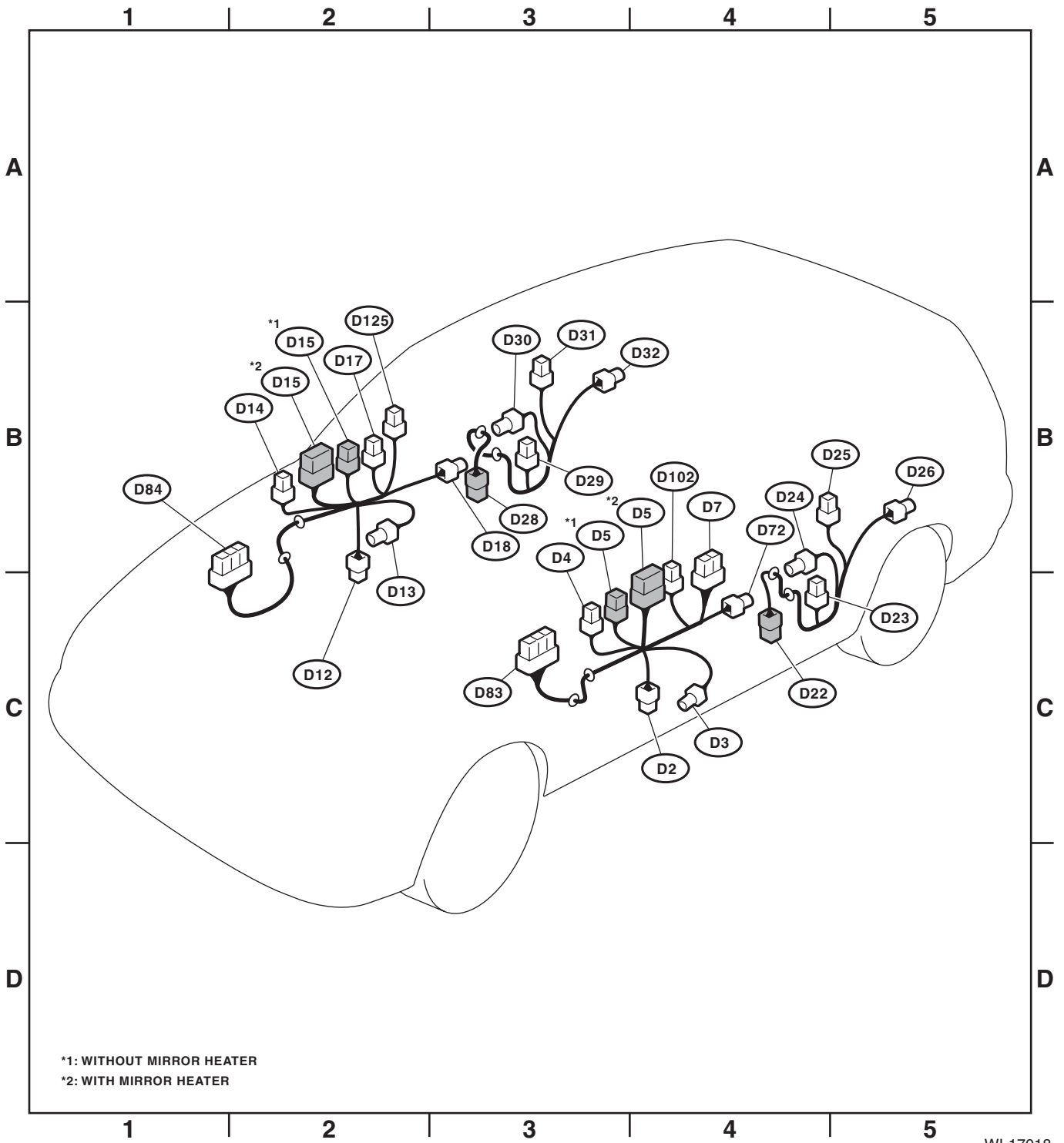

WI-17018

# Rear Wiring Harness and Trunk Lid Cord

WIRING SYSTEM

Brought to you by  
 NOT FOR SALE  
 Chris Studios

## 59.Rear Wiring Harness and Trunk Lid Cord

### A: LOCATION

Connector				Connecting to	
No.	Pole	Color	Area	No.	Description
R19	2	Blue	B-3		High-mounted stop light
R20	2	★	B-4		Trunk room light
R22	3	★	B-1		Rear door switch LH
R24	8	★	B-4	R60	Trunk lid cord
R26	6	★	B-5		Rear combination light RH
R28	6	★	C-3		Rear combination light LH
R60	8	★	B-4	R24	Rear wiring harness
R65	1	★	B-2		Rear defogger
R66	2	★	B-4		High-mounted stop light (Rear spoiler)
R76	2	★	C-4		License plate light
R80	8	★	B-2		Keyless entry control module
R86	2	★	C-4		Drain valve
R97	1	★	B-2		Antenna amplifier
R122	10	★	B-5		Fuel pump control unit
R174	1	★	B-4		Rear defogger
R186	3	★	C-4		Trunk lid lock actuator & switch

★ : White or natural color

Connector				Connecting to	
No.	Pole	Color	Area	No.	Description
AB31	2	Yellow	B-2		Curtain airbag module LH
AB32	4	Yellow	B-1		Curtain airbag sensor LH
AB33	2	Yellow	B-4		Curtain airbag module RH

# Rear Wiring Harness and Trunk Lid Cord

WIRING SYSTEM

Brought to you by Eris Studios  
NOT FOR RESALE

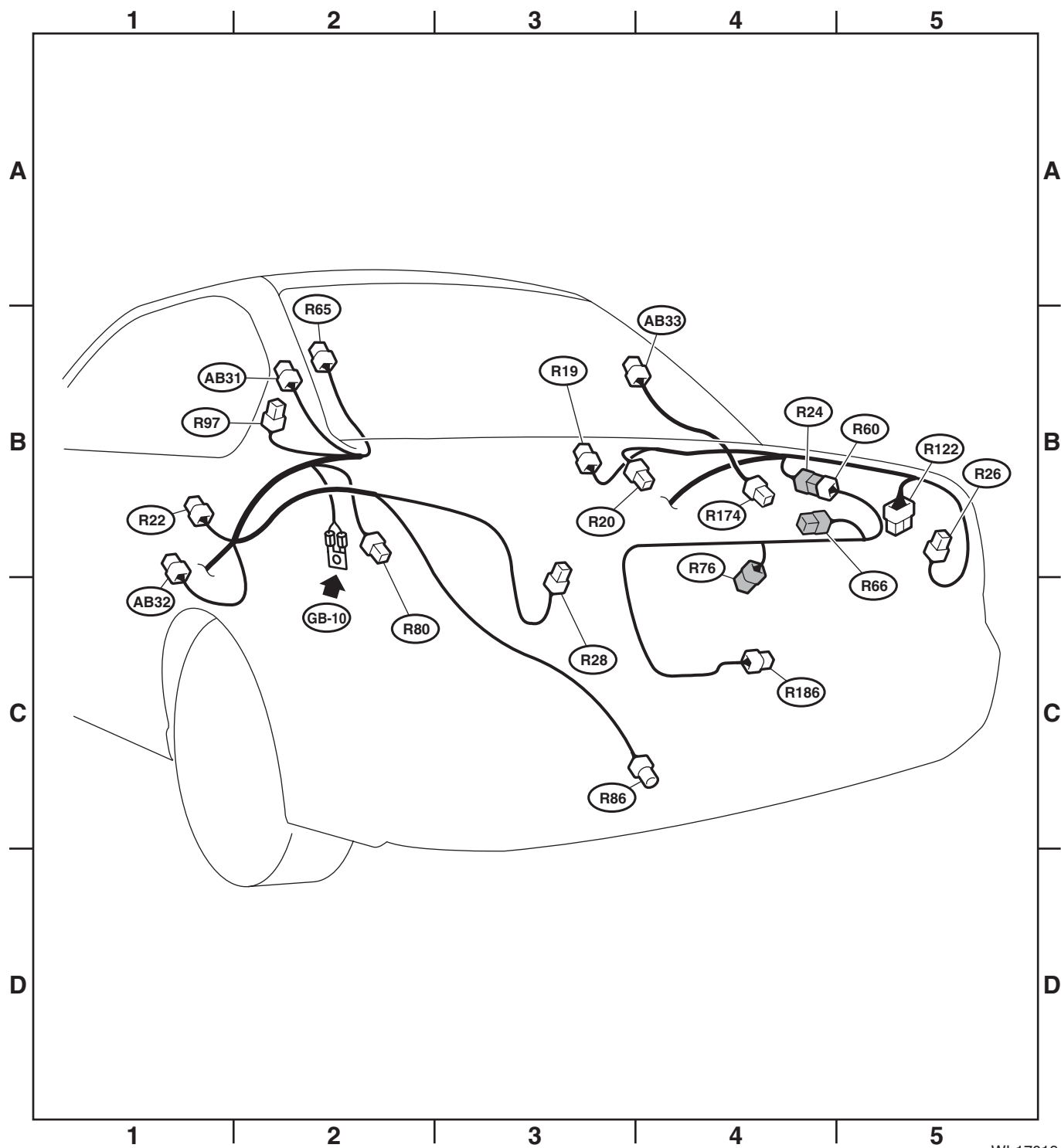

WI-17019

# Rear Wiring Harness and Rear Gate Cord

WIRING SYSTEM

Brought to you by  
NOT FOR SALE  
Chris Studios

## 60.Rear Wiring Harness and Rear Gate Cord

### A: LOCATION

Connector				Connecting to	
No.	Pole	Color	Area	No.	Description
R22	3	★	C-1		Rear door switch LH
R26	4	Light gray	C-5		Rear combination light RH
R28	4	Light gray	C-2		Rear combination light LH
R38	8	★	C-4	D34	Rear gate cord
R39	14	★	B-4	D35	
R80	8	★	C-1		Keyless entry control module
R86	2	★	C-3		Drain valve
R97	1	★	C-2		Antenna amplifier
R122	10	★	C-4		Fuel pump control unit
R141	2	★	C-2		Luggage room light

★ : White or natural color

Connector				Connecting to	
No.	Pole	Color	Area	No.	Description
D34	8	★	B-4	R38	Rear wiring harness
D35	14	★	B-4	R39	
D39	2	★	B-3		High-mounted stop light
D43	4	★	B-4		Rear wiper motor
D44	2	★	B-4		License plate light RH
D46	4	★	A-4		Rear gate lock actuator & latch switch
D47	2	★	A-4		Rear gate opener switch
D48	1	★	B-3		Rear defogger (-)
D58	2	★	B-5		Back-up light RH
D59	2	★	A-3		Back-up light LH
D89	1	★	B-4		Rear defogger (+)
D137	2	★	B-4		License plate light LH

★ : White or natural color

Connector				Connecting to	
No.	Pole	Color	Area	No.	Description
AB31	2	Yellow	C-2		Curtain airbag module LH
AB32	4	Yellow	C-1		Curtain airbag sensor LH
AB33	2	Yellow	C-4		Curtain airbag module RH

# Rear Wiring Harness and Rear Gate Cord

WIRING SYSTEM

Brought to you by Eris Studios  
NOT FOR RESALE

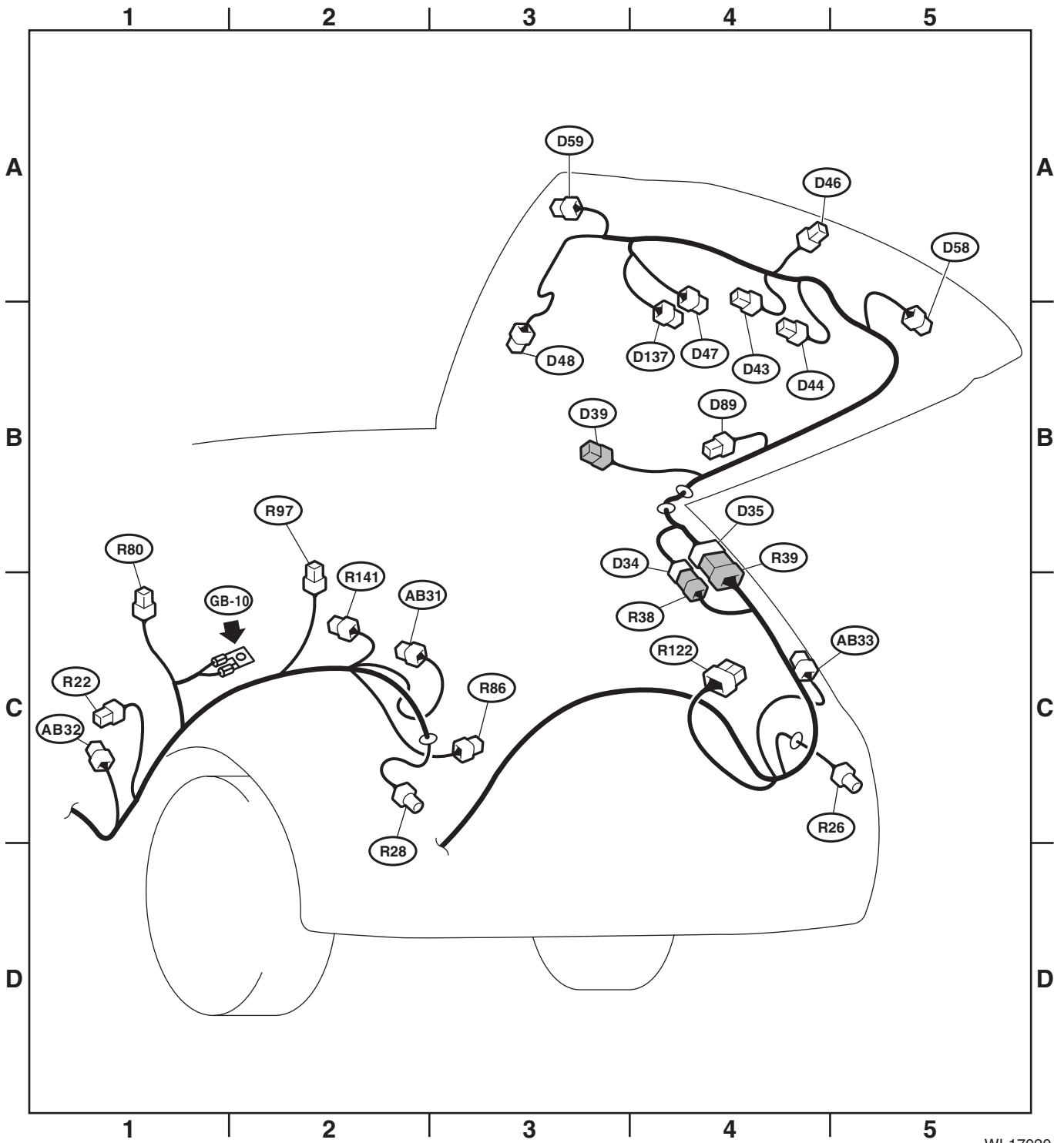

WI-17020