

2. Radiator Fan System

A: WIRING DIAGRAM

Radiator Fan System <Ref. to WI-120, WIRING DIAGRAM, Radiator Fan System.>

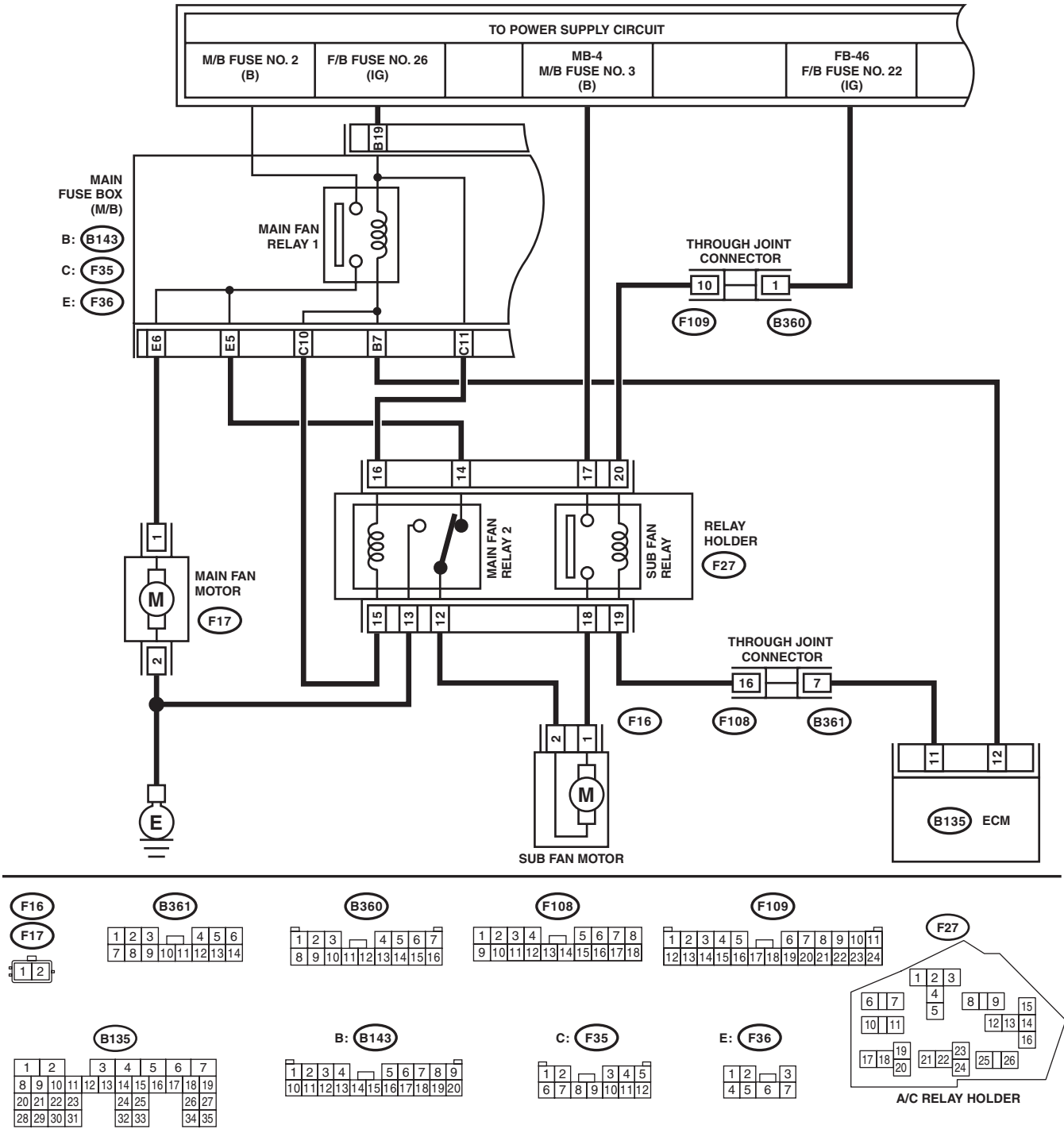

Radiator Fan System

COOLING

B: INSPECTION

OPERATING CONDITION:

Vehicle speed	A/C compressor load	Engine coolant temperature		
		Increase: 98°C (208°F) or less Decrease: 96°C (205°F) or less	Increase: 99 — 101°C (210 — 214°F) Decrease: 97 — 98°C (207 — 208°F)	Increase: 102°C (216°F) or more Decrease: 99°C (210°F) or more
		Radiator fan operation	Radiator fan operation	Radiator fan operation
During acceleration: 19 km/h (12 MPH) or less During deceleration: 10 km/h (6 MPH) or less	OFF	OFF	Low-Speed	High-Speed
	Low	Low-Speed	Low-Speed	High-Speed
	High	High-Speed	High-Speed	High-Speed
During acceleration: 20 — 69 km/h (12 — 43 MPH) During deceleration: 11 — 64 km/h (7 — 40 MPH)	OFF	OFF	Low-Speed	High-Speed
	Low	High-Speed	High-Speed	High-Speed
	High	High-Speed	High-Speed	High-Speed
During acceleration: 70 — 134 km/h (43 — 83 MPH) During deceleration: 65 — 129 km/h (40 — 80 MPH)	OFF	OFF	Low-Speed	High-Speed
	Low	OFF	Low-Speed	High-Speed
	High	Low-Speed	High-Speed	High-Speed
During acceleration: 135 km/h (84 MPH) or more During deceleration: 130 km/h (81 MPH) or more	OFF	OFF	OFF	High-Speed
	Low	OFF	Low-Speed	High-Speed
	High	OFF	Low-Speed	High-Speed

DIAGNOSIS:

Radiator main fan and radiator sub fans do not rotate under the above operating conditions.

Step	Check	Yes	No
<p>1</p> <p>CHECK OPERATION OF RADIATOR FAN. 1) Connect the delivery (test) mode connector. 2) Turn the ignition switch to ON. 3) Perform the compulsory operation check for the radiator fan relay using Subaru Select Monitor.</p> <p>NOTE: • When performing a forced operation radiator fan relay check using the Subaru Select Monitor, the radiator main fan and radiator sub fan will repeat low speed revolution → high speed revolution → OFF in this order. • Subaru Select Monitor For detailed operation procedures, refer to “PC application help for Subaru Select Monitor”.</p>	Do the radiator main fans and radiator sub fans rotate at low speed?	Go to step 2.	Go to step 3.
<p>2</p> <p>CHECK OPERATION OF RADIATOR FAN. 1) Connect the delivery (test) mode connector. 2) Turn the ignition switch to ON. 3) Perform the compulsory operation check for the radiator fan relay using Subaru Select Monitor.</p> <p>NOTE: • When performing a forced operation radiator fan relay check using the Subaru Select Monitor, the radiator main fan and radiator sub fan will repeat low speed revolution → high speed revolution → OFF in this order. • Subaru Select Monitor For detailed operation procedures, refer to “PC application help for Subaru Select Monitor”.</p>	Do the radiator main fans and radiator sub fans rotate at high speed?	Radiator main fan system is normal.	Go to step 27.
<p>3</p> <p>CHECK POWER SUPPLY TO SUB FAN RELAY. 1) Turn the ignition switch to OFF. 2) Remove the sub fan relay from the relay holder. 3) Measure the voltage between the sub fan relay terminal and chassis ground.</p> <p>Connector & terminal (F27) No. 17 (+) — Chassis ground (-):</p>	Is the voltage 10 V or more?	Go to step 4.	Go to step 5.
<p>4</p> <p>CHECK POWER SUPPLY TO SUB FAN RELAY. 1) Turn the ignition switch to ON. 2) Measure the voltage between the sub fan relay terminal and chassis ground.</p> <p>Connector & terminal (F27) No. 20 (+) — Chassis ground (-):</p>	Is the voltage 10 V or more?	Go to step 7.	Go to step 6.
<p>5</p> <p>CHECK FUSE. 1) Turn the ignition switch to OFF. 2) Remove the fuse No. 3. 3) Check the condition of fuse.</p>	Is the fuse blown out?	Replace the fuse.	Repair the power supply line.
<p>6</p> <p>CHECK FUSE. 1) Turn the ignition switch to OFF. 2) Remove the fuse No. 22. 3) Check the condition of fuse.</p>	Is the fuse blown out?	Replace the fuse.	Repair the power supply line.

Radiator Fan System

COOLING

Step	Check	Yes	No
7 CHECK SUB FAN RELAY. 1) Turn the ignition switch to OFF. 2) Measure the resistance between sub fan relay terminals. Terminals No. 17 — No. 18:	Is the resistance 1 M Ω or more?	Go to step 8.	Replace the sub fan relay. <Ref. to AC-32, Relay and Fuse.>
8 CHECK SUB FAN RELAY. 1) Connect the battery to terminals No. 13 and No. 12 of the sub fan relay. 2) Measure the resistance between sub fan relay terminals. Terminals No. 17 — No. 18:	Is the resistance less than 1 Ω ?	Go to step 9.	Replace the sub fan relay. <Ref. to AC-32, Relay and Fuse.>
9 CHECK HARNESS BETWEEN SUB FAN RELAY TERMINAL AND SUB FAN MOTOR CONNECTOR. 1) Disconnect the connector from the sub fan motor. 2) Measure the resistance of harness between the sub fan relay terminal and sub fan motor connector. Connector & terminal (F16) No. 1 — (F27) No. 18:	Is the resistance less than 1 Ω ?	Go to step 10.	Repair the open circuit of harness between sub fan relay terminal and sub fan motor connector.
10 CHECK HARNESS BETWEEN SUB FAN MOTOR CONNECTOR AND MAIN FAN RELAY 2 CONNECTOR. 1) Remove main fan relay 2 from the relay holder. 2) Measure the resistance of harness between sub fan motor connector and main fan relay 2 connector. Connector & terminal (F16) No. 2 — (F27) No. 12:	Is the resistance less than 1 Ω ?	Go to step 11.	Repair the open circuit of the harness between sub fan motor connector and main fan relay 2 connector.
11 CHECK FOR POOR CONTACT. Check poor contact of sub fan motor connector.	Is there poor contact of the sub fan motor connector?	Repair the poor contact of sub fan motor connector.	Go to step 12.
12 CHECK SUB FAN MOTOR. Connect the battery positive (+) terminal to terminal No. 2 of the sub fan motor, and the ground (-) terminal to terminal No. 1.	Does the radiator sub fan rotate?	Go to step 13.	Replace the sub fan motor. <Ref. to CO(H4DO)-47, Radiator Sub Fan and Fan Motor.>
13 CHECK MAIN FAN RELAY 2. Measure the resistance of main fan relay 2. Terminals No. 14 — No. 12:	Is the resistance less than 1 Ω ?	Go to step 14.	Replace the main fan relay 2. <Ref. to AC-32, Relay and Fuse.>
14 CHECK HARNESS BETWEEN MAIN FAN RELAY 2 AND MAIN FAN MOTOR CONNECTOR. 1) Disconnect the connector from the main fan motor. 2) Measure the resistance of the harness between main fan relay 2 terminal and main fan motor connector. Connector & terminal (F17) No. 1 — (F27) No. 14:	Is the resistance less than 1 Ω ?	Go to step 15.	Repair the open circuit of the harness between main fan relay 2 terminal and main fan motor connector.

Radiator Fan System

COOLING

Step	Check	Yes	No
15 CHECK GROUND CIRCUIT OF MAIN FAN MOTOR. Measure the resistance between main fan motor connector and chassis ground. Connector & terminal (F17) No. 2 — Chassis ground:	Is the resistance less than 5 Ω?	Go to step 16.	Repair the open circuit of the harness between main fan motor connector and chassis ground.
16 CHECK FOR POOR CONTACT. Check poor contact of main fan motor connector.	Is there poor contact of the main fan motor connector?	Repair the poor contact of main fan motor connector.	Go to step 17.
17 CHECK MAIN FAN MOTOR. Connect the battery positive (+) terminal to terminal No. 2 of the main fan motor, and the ground (-) terminal to terminal No. 1.	Does the radiator main fan rotate?	Go to step 18.	Replace the main fan motor. <Ref. to CO(H4DO)-43, Radiator Main Fan and Fan Motor.>
18 CHECK HARNESS BETWEEN SUB FAN RELAY AND ECM. 1) Disconnect the connector from ECM. 2) Measure the resistance between the sub fan relay terminal and ECM connector. Connector & terminal (B135) No. 11 — (F27) No. 19:	Is the resistance less than 1 Ω?	Go to step 19.	Repair the open circuit of harness between sub fan relay terminal and ECM.
19 CHECK FOR POOR CONTACT. Check for poor contact of ECM connector.	Is there poor contact of ECM connector?	Repair the poor contact of ECM connector.	Check the DTC. Repair the trouble cause. <Ref. to EN(H4DO)(diag)-42, Read Diagnostic Trouble Code (DTC).>
20 CHECK MAIN FAN RELAY 1. 1) Turn the ignition switch to OFF. 2) Remove main fan relay 1 from the main fuse box. 3) Measure the resistance between terminals of main fan relay 1 switch.	Is the resistance 1 MΩ or more?	Go to step 21.	Replace the main fan relay 1. <Ref. to AC-32, Relay and Fuse.>
21 CHECK MAIN FAN RELAY 1. 1) Connect the main fan relay 1 coil side terminal to the battery. 2) Measure the resistance between terminals of main fan relay 1 switch.	Is the resistance less than 1 Ω?	Go to step 22.	Replace the main fan relay 1. <Ref. to AC-32, Relay and Fuse.>
22 CHECK HARNESS BETWEEN MAIN FAN RELAY 1 AND MAIN FAN MOTOR CONNECTOR. 1) Disconnect the connector from the main fan motor. 2) Measure the resistance of the harness between main fan relay 1 terminal and main fan motor connector. Connector & terminal (F17) No. 1 — (F36) No. 6:	Is the resistance less than 1 Ω?	Go to step 23.	Repair the open circuit of the harness between main fan relay 1 terminal and main fan motor connector.
23 CHECK HARNESS BETWEEN MAIN FAN RELAY 1 AND ECM. 1) Disconnect the connector from ECM. 2) Measure the resistance between main fan relay 1 terminal and ECM connector. Connector & terminal (B135) No. 12 — (B143) No. 15:	Is the resistance less than 1 Ω?	Go to step 24.	Repair the open circuit of the harness between main fan relay 1 terminal and ECM.

Radiator Fan System

COOLING

Step	Check	Yes	No
24 CHECK HARNESS BETWEEN MAIN FAN RELAY 2 AND ECM. Measure the resistance between main fan relay 2 terminal and ECM connector. Connector & terminal (B135) No. 12 — (F27) No. 15:	Is the resistance less than 1 Ω?	Go to step 25.	Repair the open circuit of the harness between main fan relay 2 terminal and ECM.
25 CHECK FUSE. 1) Turn the ignition switch to OFF. 2) Remove the fuse No. 2 and No. 26. 3) Check the condition of fuse.	Is the fuse blown out?	Replace the fuse.	Go to step 26.
26 CHECK FOR POOR CONTACT. Check for poor contact of ECM connector.	Is there poor contact of ECM connector?	Repair the poor contact of ECM connector.	Repair the power supply circuit to the main fuse box.
27 CHECK OPERATION OF RADIATOR FAN. If the both fans do not rotate at high speed in the condition of step 2, check whether the radiator sub fan is rotating.	Does the radiator sub fan rotate?	Go to step 20.	Go to step 28.
28 CHECK GROUND CIRCUIT OF MAIN FAN RELAY 2. 1) Remove the main fan relay 2 from A/C relay holder. 2) Measure the resistance between main fan relay 2 terminal and chassis ground. Connector & terminal (F27) No. 13 — Chassis ground:	Is the resistance less than 1 Ω?	Go to step 29.	Repair the open circuit of harness between main fan relay 2 and chassis ground.
29 CHECK POWER SUPPLY TO MAIN FAN RELAY 2. 1) Turn the ignition switch to ON. 2) Measure the voltage between main fan relay 2 terminal and chassis ground. Connector & terminal (F27) No. 16 (+) — Chassis ground (-):	Is the voltage 10 V or more?	Go to step 30.	Repair the power supply line.
30 CHECK MAIN FAN RELAY 2. 1) Turn the ignition switch to OFF. 2) Remove the main fan relay 2. 3) Measure the resistance of main fan relay 2. Terminals (F27) No. 12 — (F27) No. 13:	Is the resistance 1 MΩ or more?	Go to step 31.	Replace the main fan relay 2. <Ref. to AC-32, Relay and Fuse.>
31 CHECK MAIN FAN RELAY 2. 1) Connect the battery to terminals No. 20 and No. 22 of the main fan relay 2. 2) Measure the resistance of main fan relay 2. Terminals (F27) No. 12 — (F27) No. 13:	Is the resistance less than 1 Ω?	Go to step 23.	Replace the main fan relay 2. <Ref. to AC-32, Relay and Fuse.>