

# Radiator

## COOLING

### 6. Radiator

#### A: REMOVAL

##### CAUTION:

The radiator is pressurized when the engine and radiator are hot. Wait until engine and radiator cool down before working on the radiator.

- 1) Remove the V-belt covers.

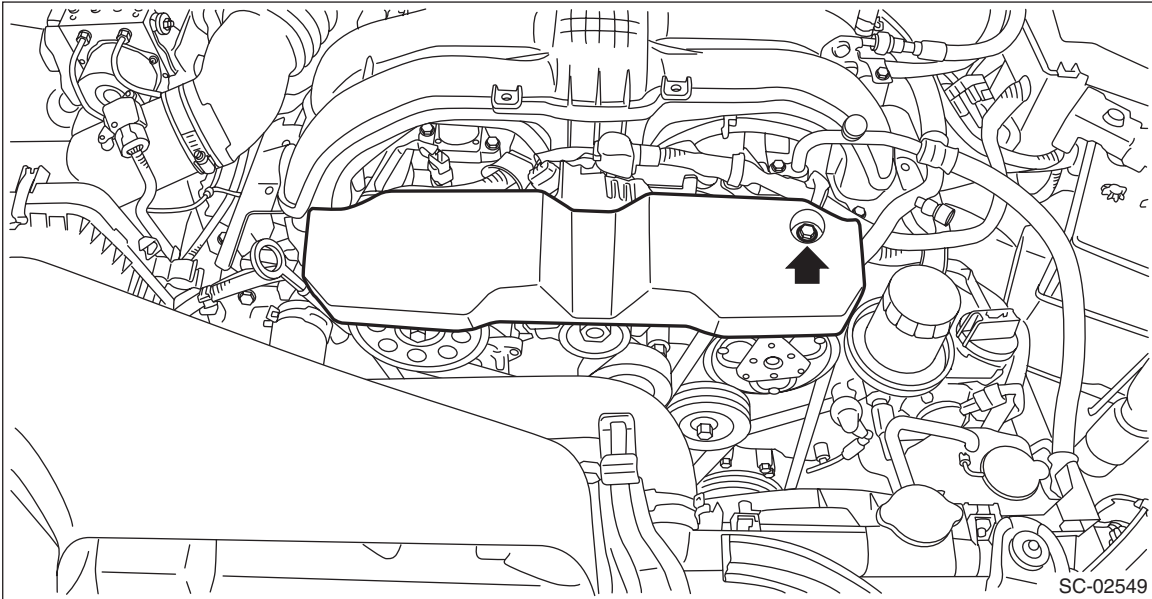

- 2) Remove the clip, and remove the bracket - grille.
- 3) Remove the bolts, and remove the bracket - plate (A).

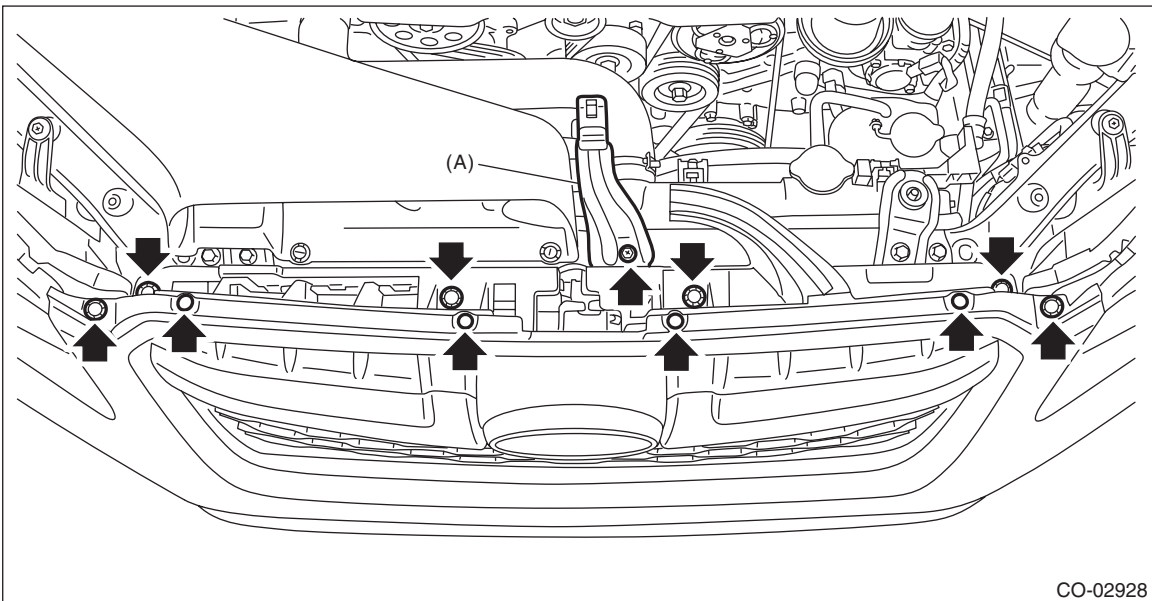

- 4) Disconnect the ground cable from battery.

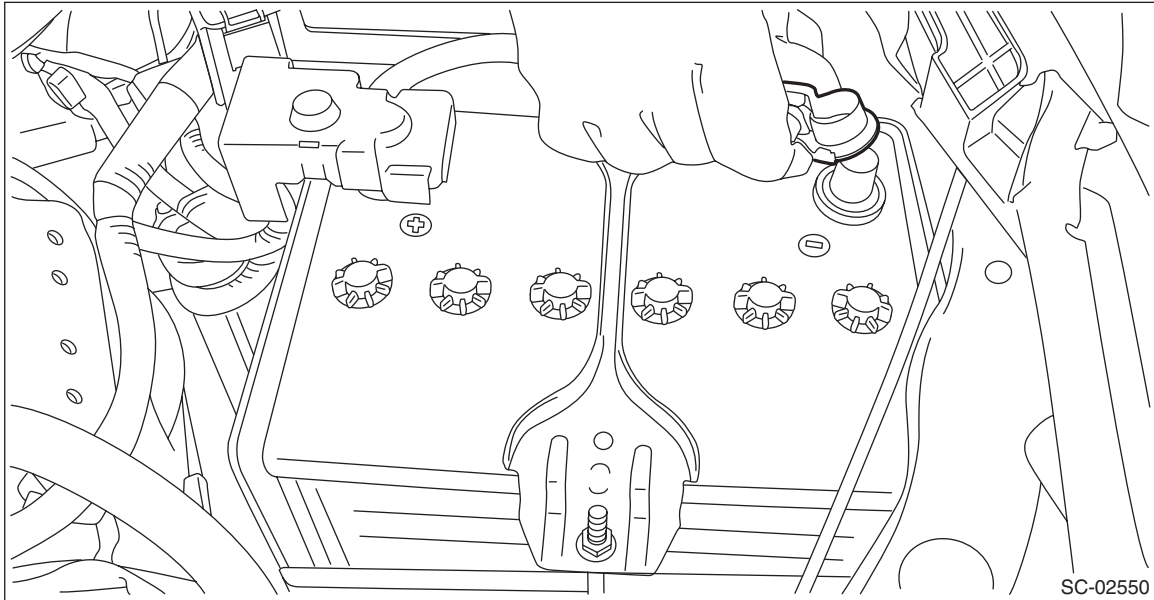

- 5) Lift up the vehicle.

- 6) Drain engine coolant. <Ref. to CO(H4DO)-13, DRAINING OF ENGINE COOLANT, REPLACEMENT, Engine Coolant.>

- 7) Disconnect the radiator outlet hose from thermostat cover.

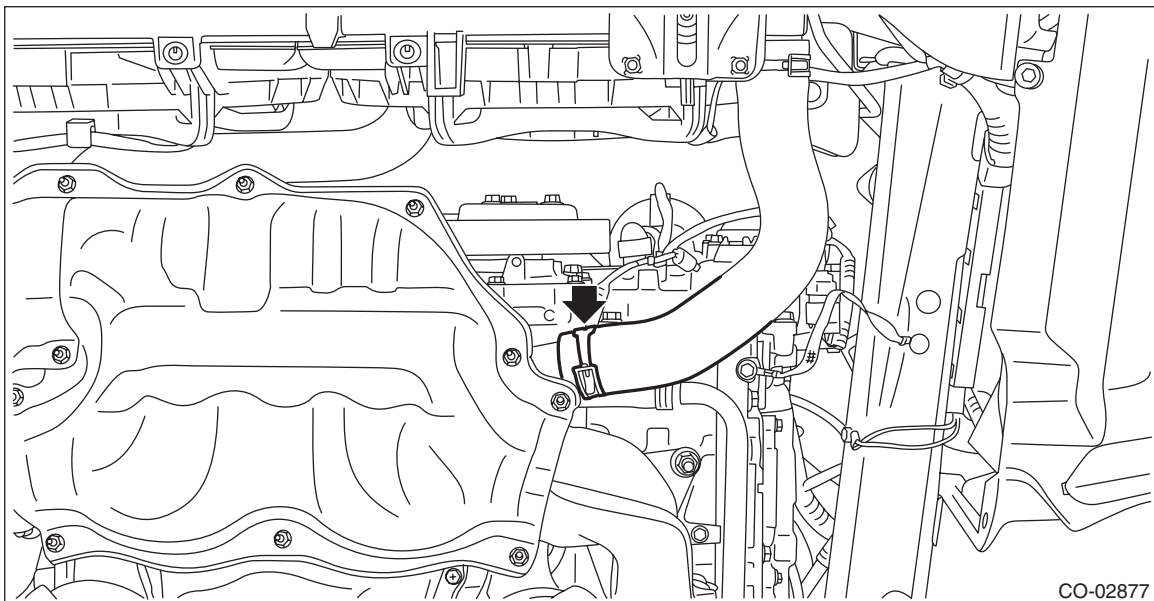

- 8) Lower the vehicle.

- 9) Remove the air intake duct. <Ref. to IN(H4DO)-13, REMOVAL, Air Intake Duct.>

- 10) Remove the reservoir tank. <Ref. to CO(H4DO)-51, REMOVAL, Reservoir Tank.>

# Radiator

## COOLING

11) Disconnect the connector (A) from the main fan motor assembly and the connector (B) from the sub fan motor assembly.

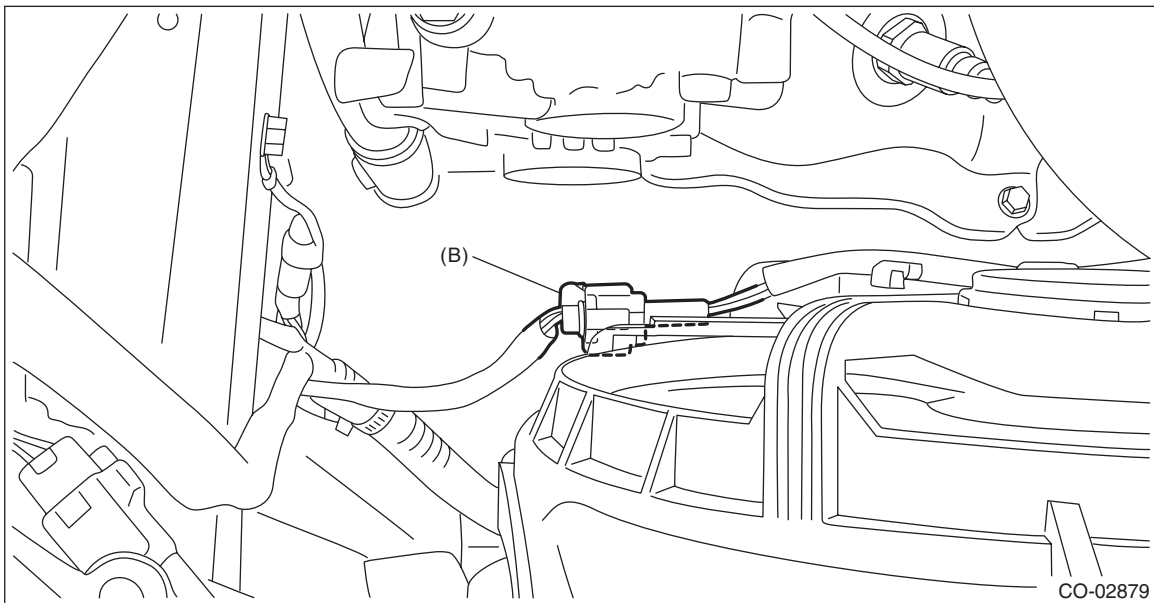
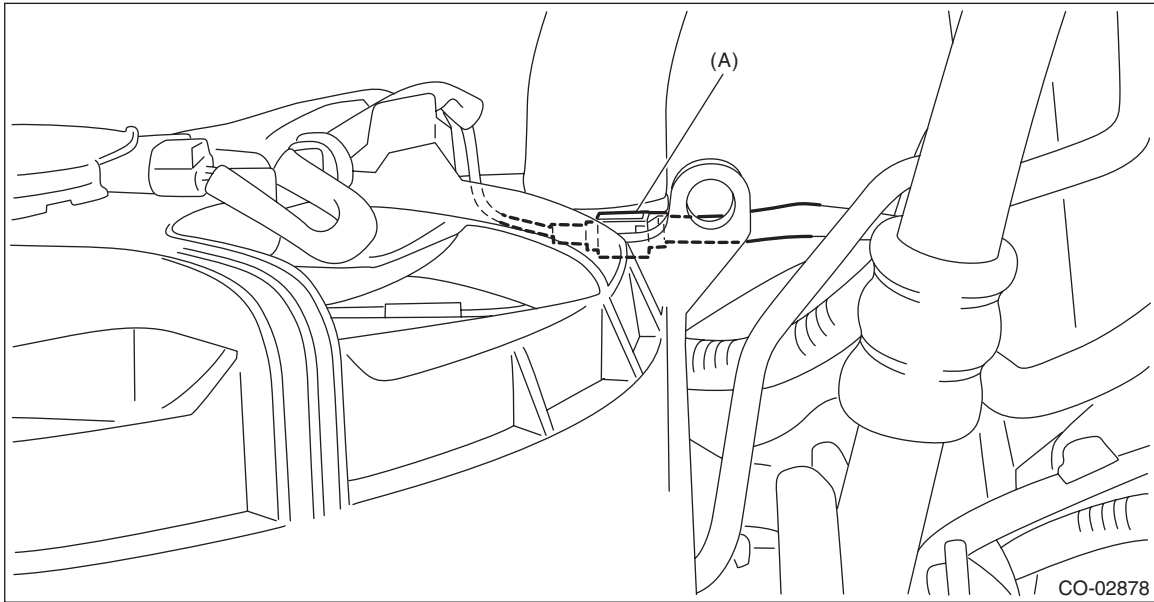

12) Disconnect the radiator inlet hose from the water pipe assembly.

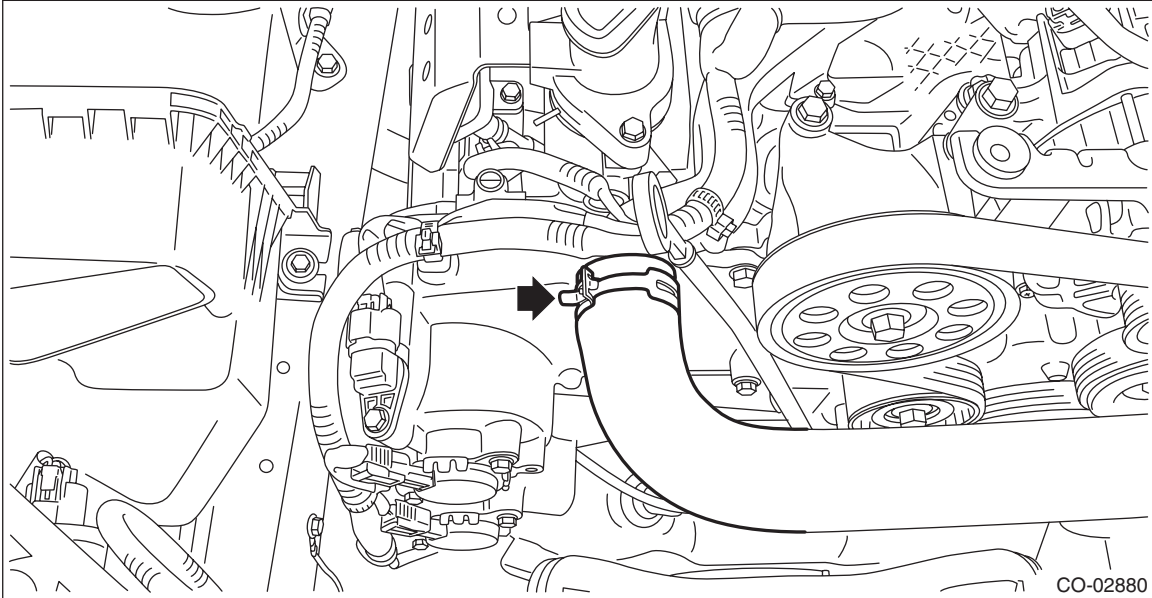

13) Remove the radiator upper brackets.

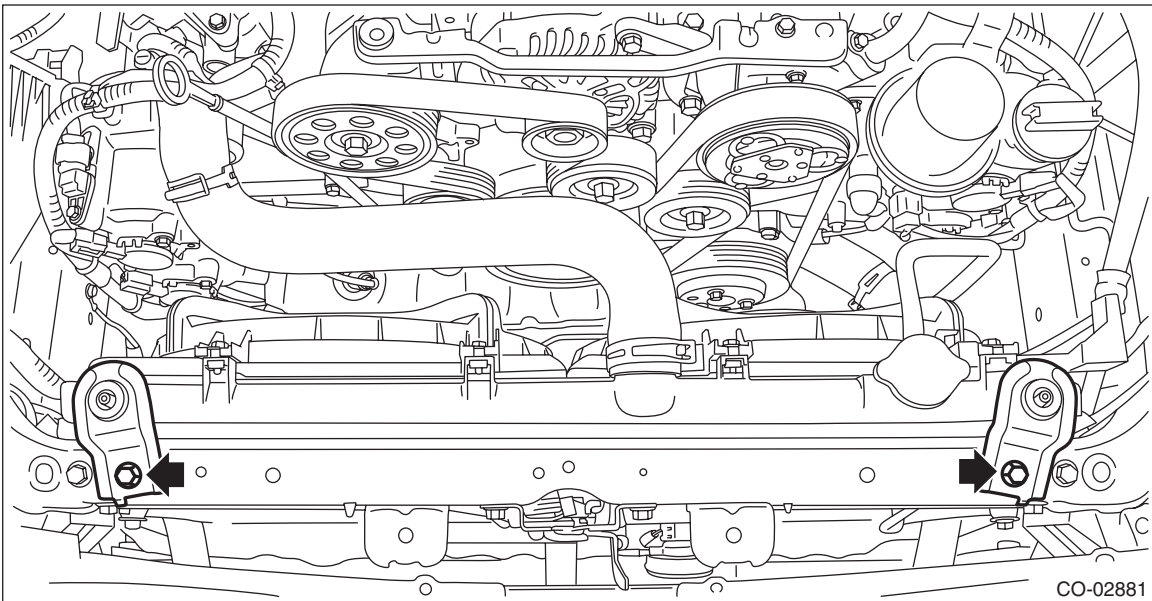

14) Lift the radiator up and away from vehicle.

# Radiator

## COOLING

### B: INSTALLATION

- 1) Attach the radiator lower cushion to the radiator lower bracket.

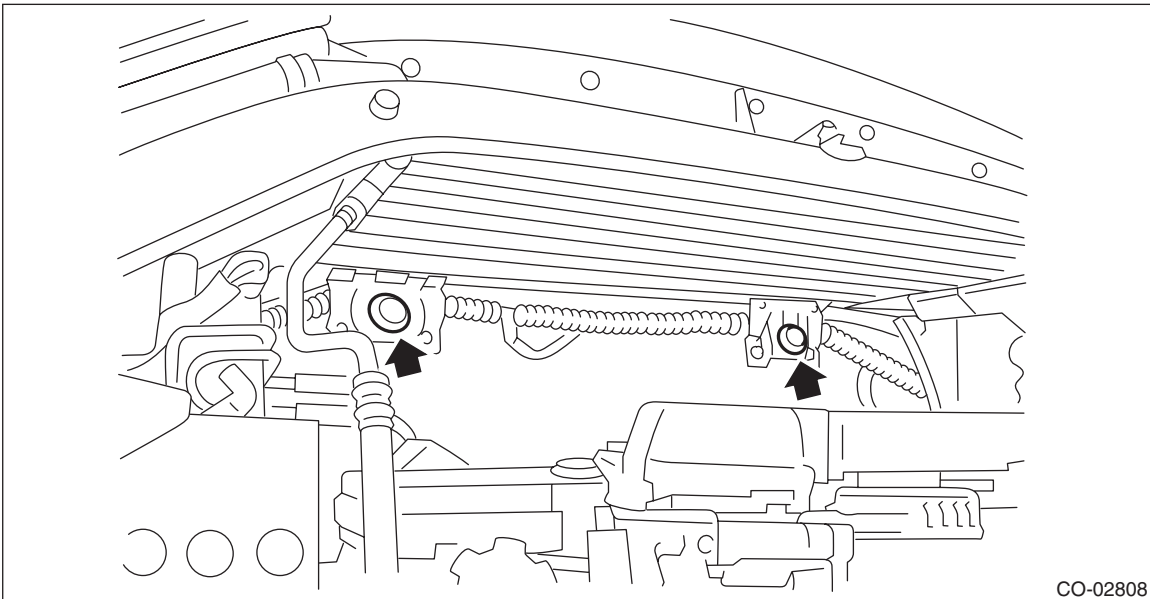

- 2) Install the radiator to vehicle.

**NOTE:**

Make pins on the lower side of radiator be fitted into the radiator lower cushions.

- 3) Install the radiator upper brackets.

**Tightening torque:**

**12 N·m (1.2 kgf·m, 8.9 ft·lb)**

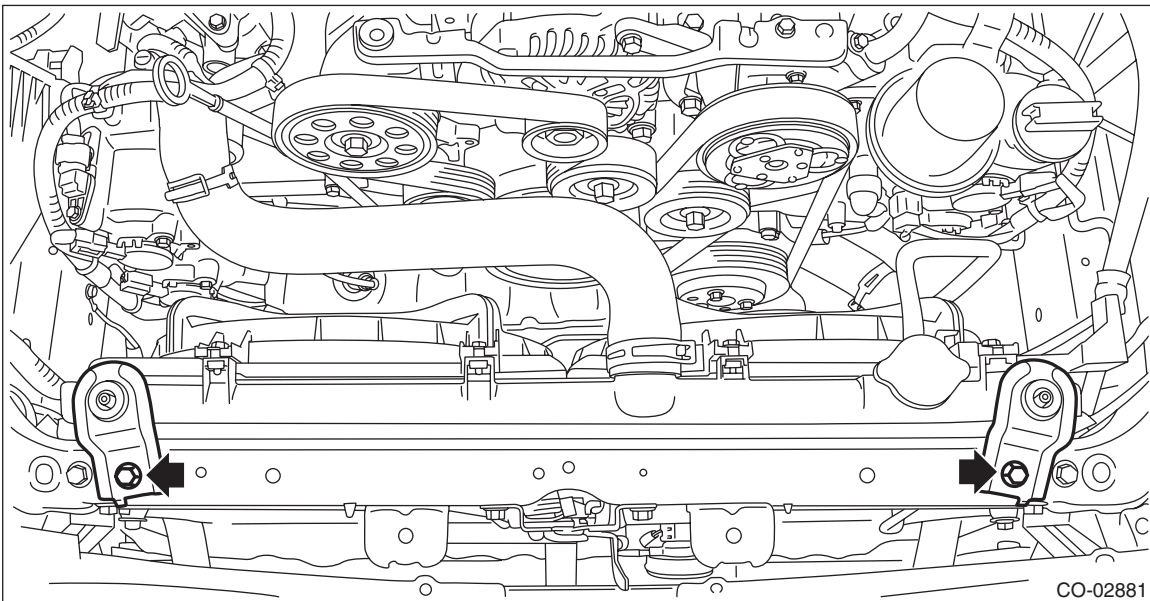

4) Connect the radiator inlet hose to the water pipe assembly.

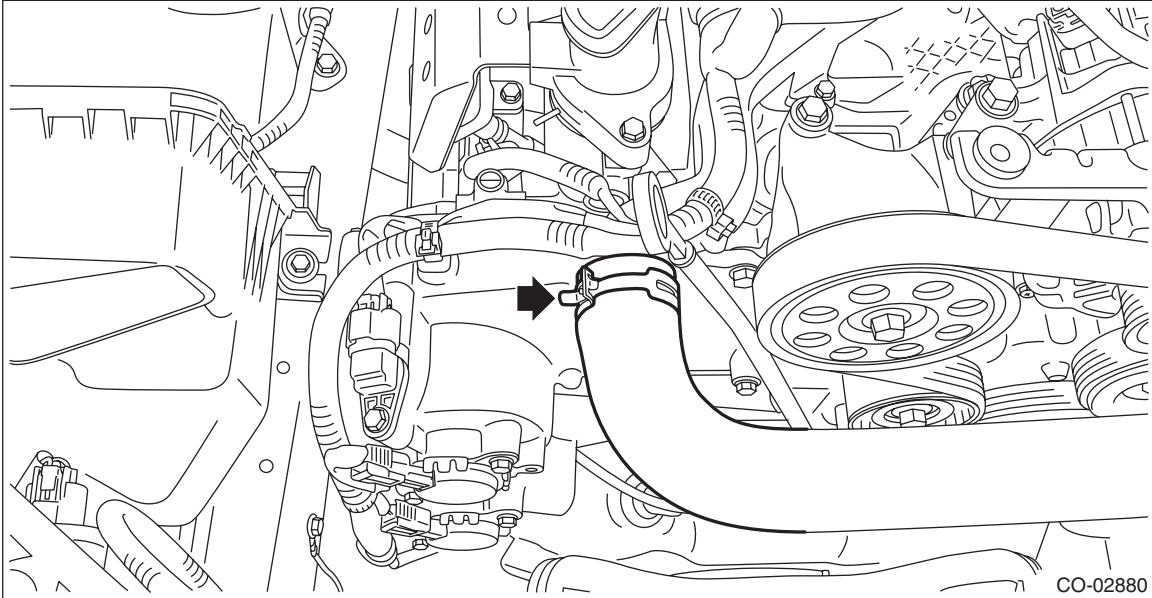

# Radiator

## COOLING

5) Connect the connector (A) to the main fan motor assembly and the connector (B) to the sub fan motor assembly.

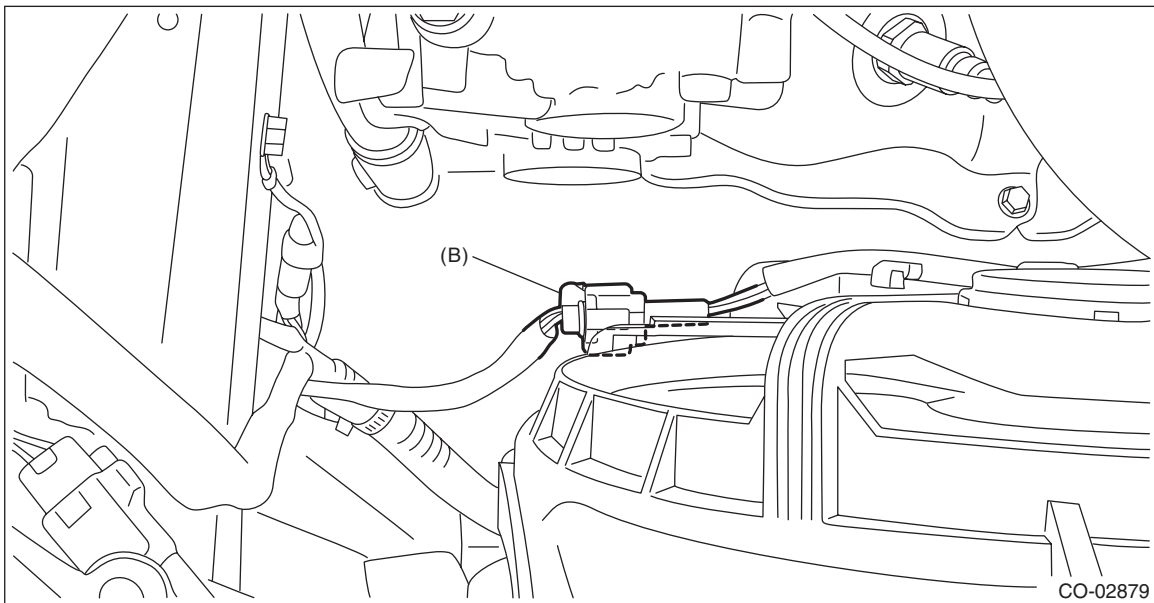
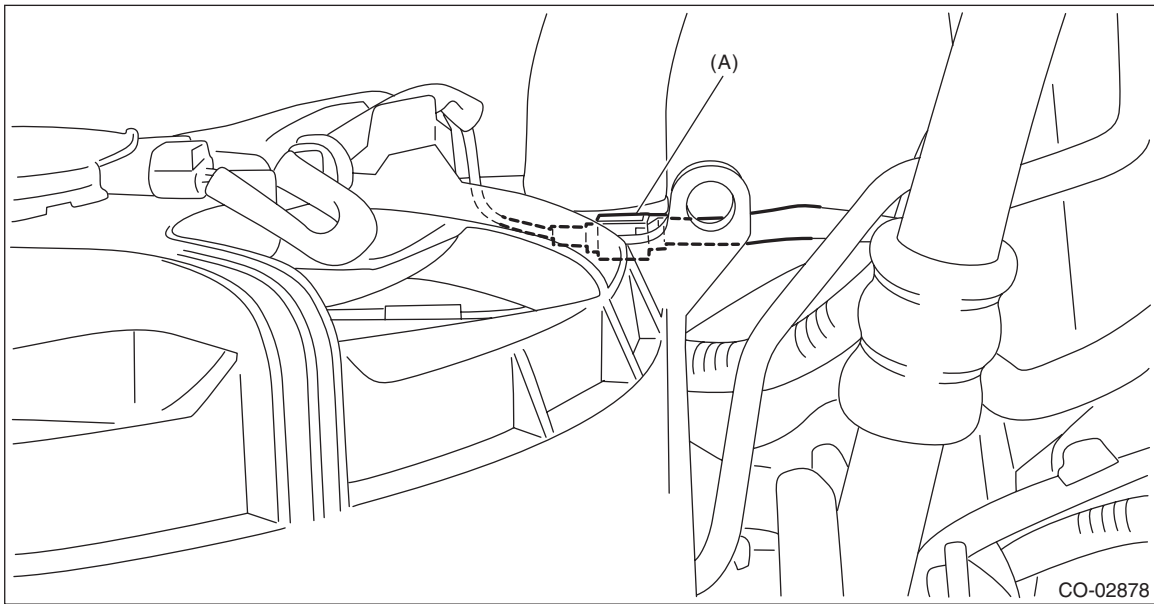

6) Install the reservoir tank. <Ref. to CO(H4DO)-51, INSTALLATION, Reservoir Tank.>

7) Install the air intake duct. <Ref. to IN(H4DO)-13, INSTALLATION, Air Intake Duct.>

8) Lift up the vehicle.

9) Connect the radiator outlet hose.

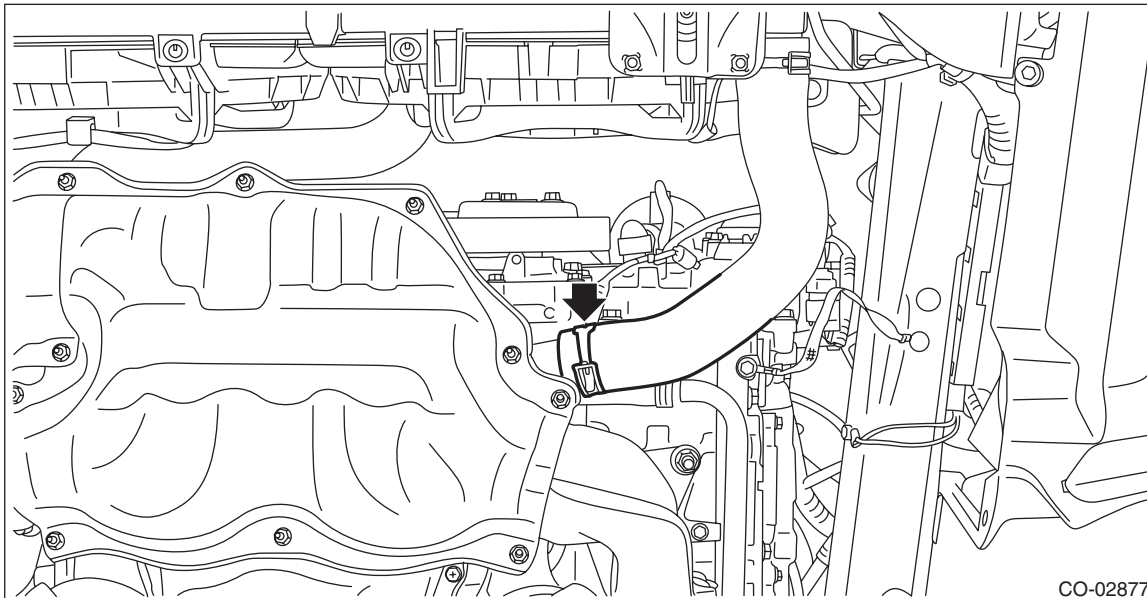

10) Lower the vehicle.

11) Attach the bracket - plate (A).

**Tightening torque:**

**7.5 N·m (0.8 kgf-m, 5.5 ft-lb)**

12) Attach the bracket - grille.

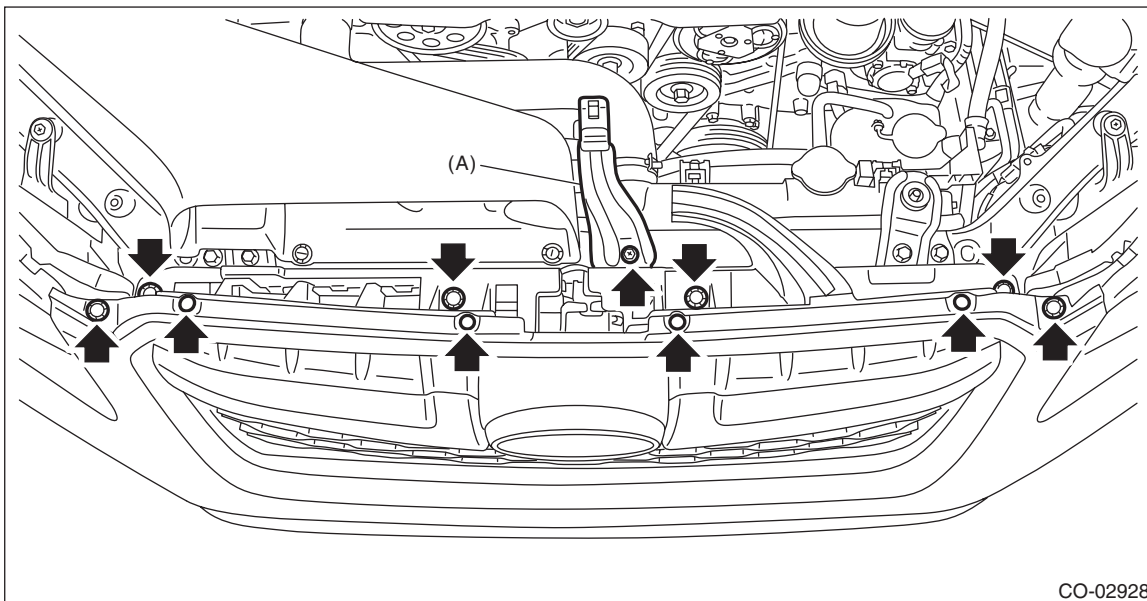



# Radiator

## COOLING

13) Install the V-belt cover.

**Tightening torque:**

**13 N·m (1.3 kgf-m, 9.6 ft-lb)**

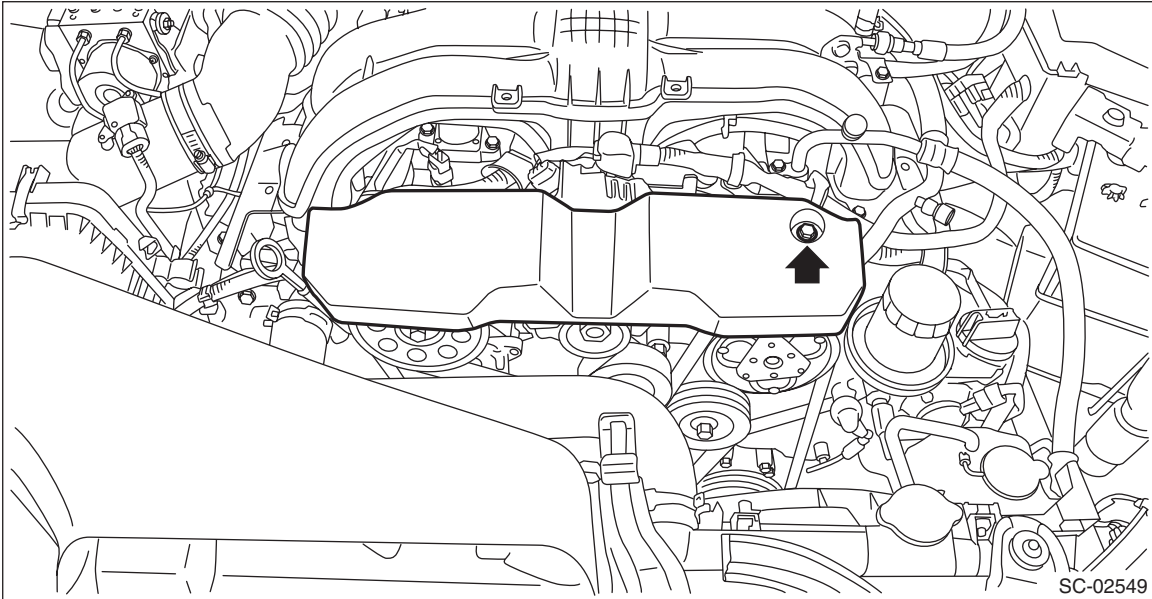

14) Connect the battery ground terminal.

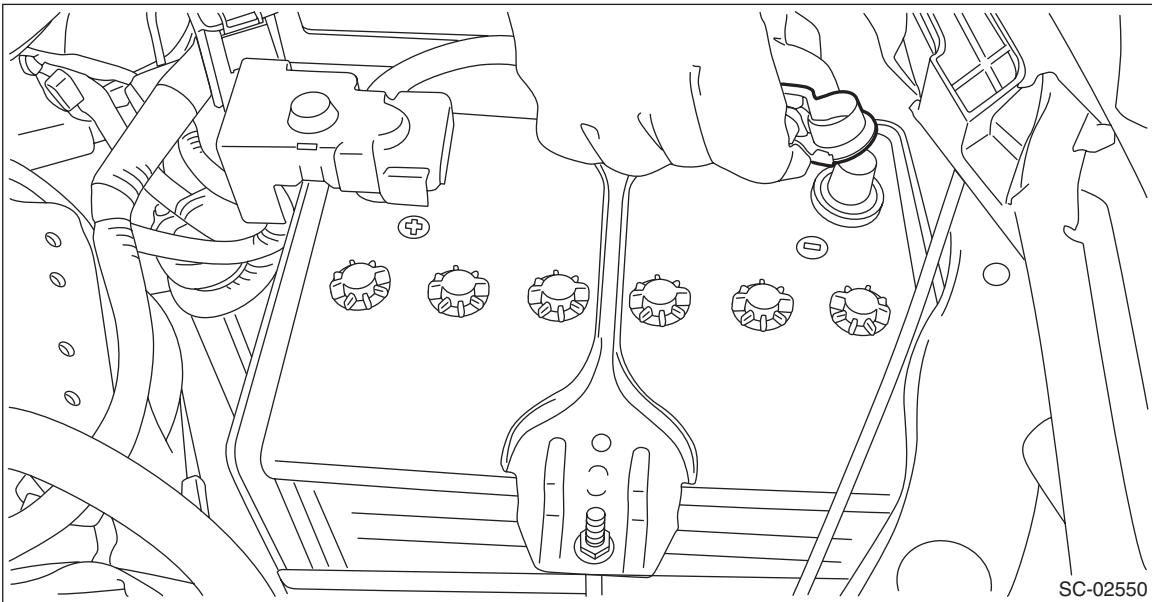

15) Fill engine coolant. <Ref. to CO(H4DO)-14, FILLING OF ENGINE COOLANT, REPLACEMENT, Engine Coolant.>

## C: INSPECTION

- 1) Check that the radiator does not have deformation, cracks or damage.
- 2) Check that the hose has no cracks, damage or loose part.
- 3) Remove the radiator cap, fill the radiator with engine coolant, and then install the radiator cap tester to the filler neck of radiator.

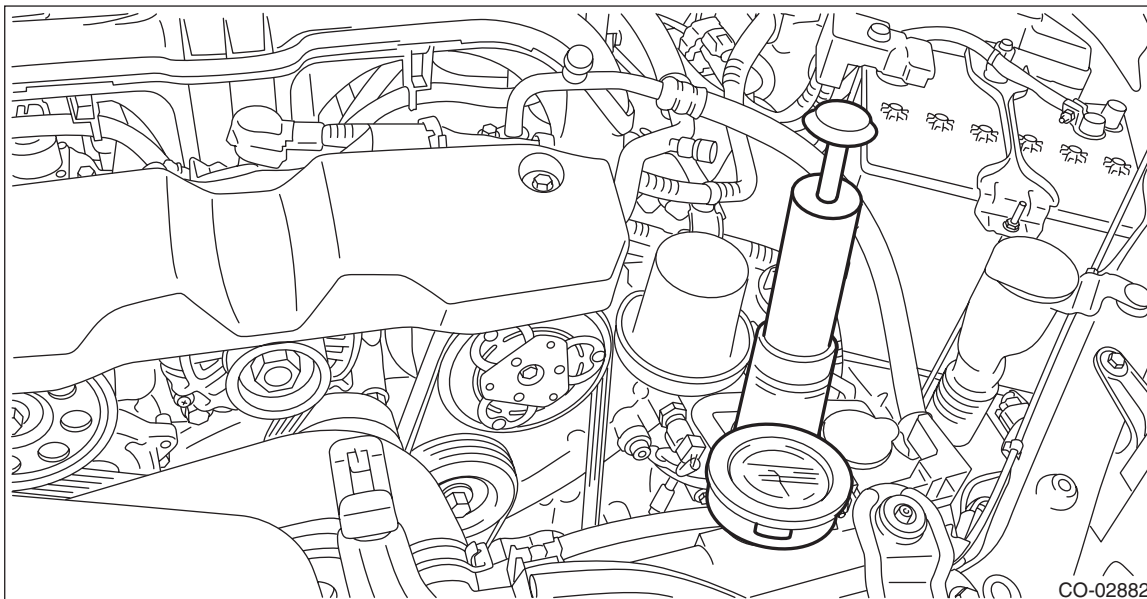

- 4) Apply a pressure of 157 kPa (1.6 kgf/cm<sup>2</sup>, 23 psi) to the radiator, and check the following items.
  - Leakage from the radiator or its vicinity
  - Leakage from the hose or its connections

### CAUTION:

- Engine should be turned off.
- Wipe engine coolant from check points in advance.
- Be careful not to deform the filler neck of radiator when installing and removing the radiator cap tester.
- Be careful of engine coolant from spurting out when removing the radiator cap tester.