

General Description

LUBRICATION

1. General Description

A: SPECIFICATION



Lubrication method			Forced lubrication		
Oil pump	Pump type		Trochoid type		
	Number of teeth	Inner rotor	11		
		Outer rotor	12		
	Outer rotor diameter × thickness		mm (in)	77 × 12 (3.03 × 0.47)	
	Performance (Oil temperature 120°C (248°F))	600 rpm	Discharge pressure	kPa (kgf/cm ² , psi)	30 (0.3, 4.3)
			Discharge rate	L (US qt, Imp qt)/min.	6.0 (6.3, 5.3) or more
		6,000 rpm	Discharge pressure	kPa (kgf/cm ² , psi)	260 (2.7, 37.7)
			Discharge rate	L (US qt, Imp qt)/min.	47 (49.7, 41.4) or more
Relief valve working pressure (2-step relief)	1st opening pressure		kPa (kgf/cm ² , psi)	150 (1.5, 21.7)	
	Main opening pressure		kPa (kgf/cm ² , psi)	570 (5.8, 82.6)	
Oil filter	Filter type		Full-flow filter type		
	Filtration area	cm ² (sq in)	Outer diameter: 68 mm (2.68 in) (Black)	1,300 (202)	
			Outer diameter: 67.4 mm (2.65 in) (Blue)	867 (134.3)	
	By-pass valve opening pressure		kPa (kgf/cm ² , psi)	160 (1.6, 23.2)	
	Outer diameter × width	mm (in)	Outer diameter: 68 mm (2.68 in) (Black)	68 × 85 (2.68 × 3.35)	
			Outer diameter: 67.4 mm (2.65 in) (Blue)	67.4 × 87.1 (2.65 × 3.43)	
Installation screw specifications			M 20 × 1.5		
Oil pressure switch	Type		Immersed contact point type		
	Operating voltage		12 V		
	Warning light operating pressure		kPa (kgf/cm ² , psi)	14.7 (0.1, 2.1)	
	Proof pressure		kPa (kgf/cm ² , psi)	981 (10, 142.2) or more	
Engine oil	Total capacity (at overhaul)		L (US qt, Imp qt)	5.7 (6.0, 5.0)	
	When replacing engine oil and oil filter		L (US qt, Imp qt)	4.8 (5.1, 4.2)	
	When replacing engine oil only		L (US qt, Imp qt)	4.6 (4.9, 4.0)	

General Description

Specified oil:

CAUTION:

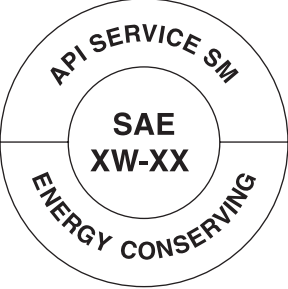
- Use 0W-20 (synthetic oil).
- It is acceptable to fill an engine with oil of another brand when replacing the oil, but make sure to use the following engine oil specified by Subaru.

Engine oil standard	SAE viscosity No.
<div style="display: flex; align-items: center; justify-content: center;"> <div style="text-align: center;">  <p>RM-00076</p> <p>Those with the API standard SM "Energy Conserving" or SN "Resource Conserving" logo.</p> </div> <div style="margin: 0 20px;">or</div> <div style="text-align: center;">  <p>RM-00002</p> <p>Those with the ILSAC standard GF-4 or GF-5 "starburst mark" displayed on top of the container.</p> </div> </div>	<p>0W-20 (synthetic oil)</p>

NOTE:

The proper viscosity oil helps the engine maintain its ideal temperature, and cranking speed increased by reducing viscosity friction in hot condition.

General Description

LUBRICATION

B: COMPONENT

1. OIL PAN AND STRAINER

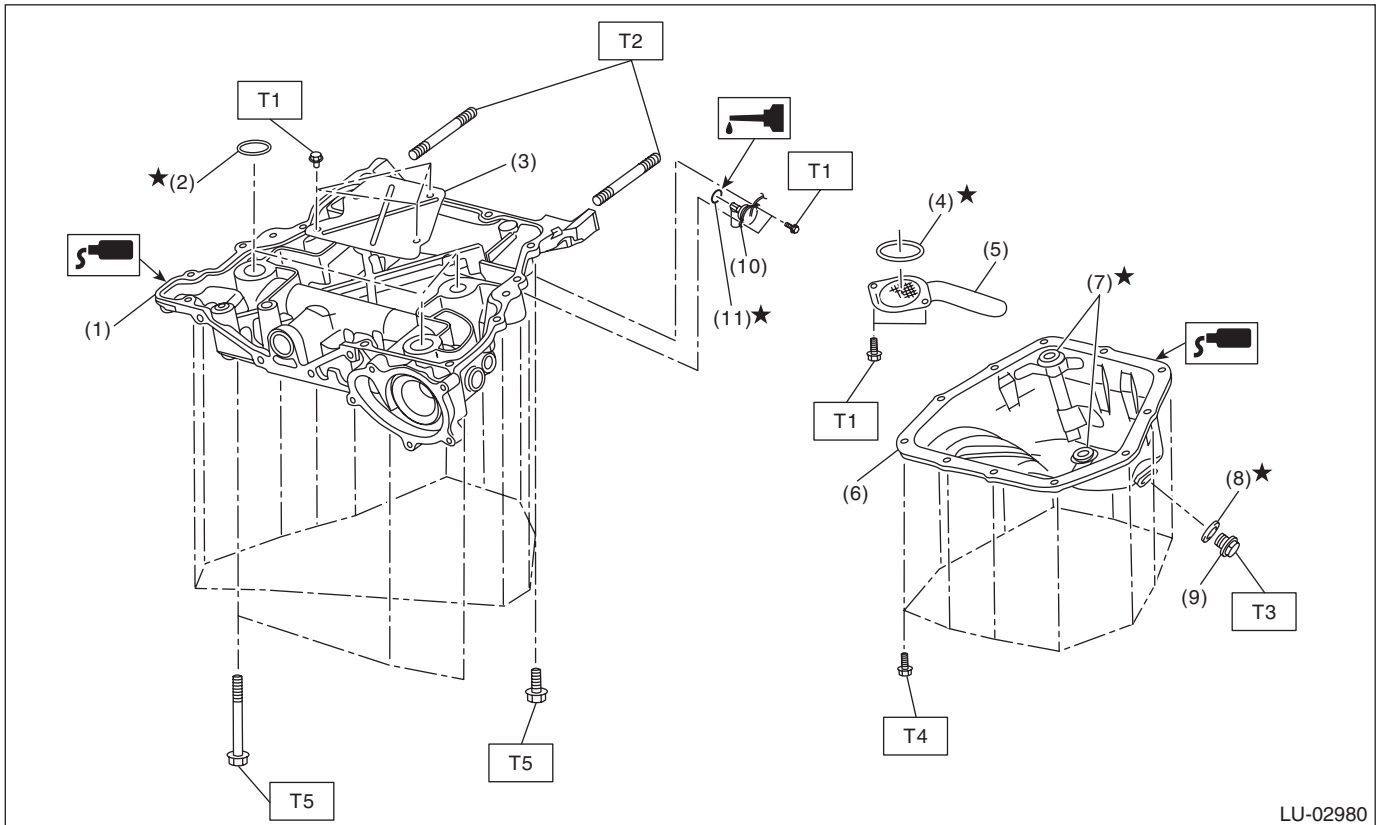

LU-02980

- | | |
|-------------------|-----------------------|
| (1) Oil pan upper | (7) Oil pan seal ring |
| (2) O-ring | (8) Drain plug gasket |
| (3) Baffle plate | (9) Drain plug |
| (4) O-ring | (10) Oil level switch |
| (5) Oil strainer | (11) O-ring |
| (6) Oil pan | |

Tightening torque: N·m (kgf-m, ft-lb)

T1: 6.4 (0.7, 4.7)

T2: 10 (1.0, 7.4)

T3: 41.7 (4.3, 30.8)

T4: <Ref. to LU(H4DO)-16, OIL PAN, INSTALLATION, Oil Pan and Strainer.>

T5: <Ref. to LU(H4DO)-18, OIL PAN UPPER, INSTALLATION, Oil Pan and Strainer.>

2. OIL FILTER AND OIL LEVEL GAUGE

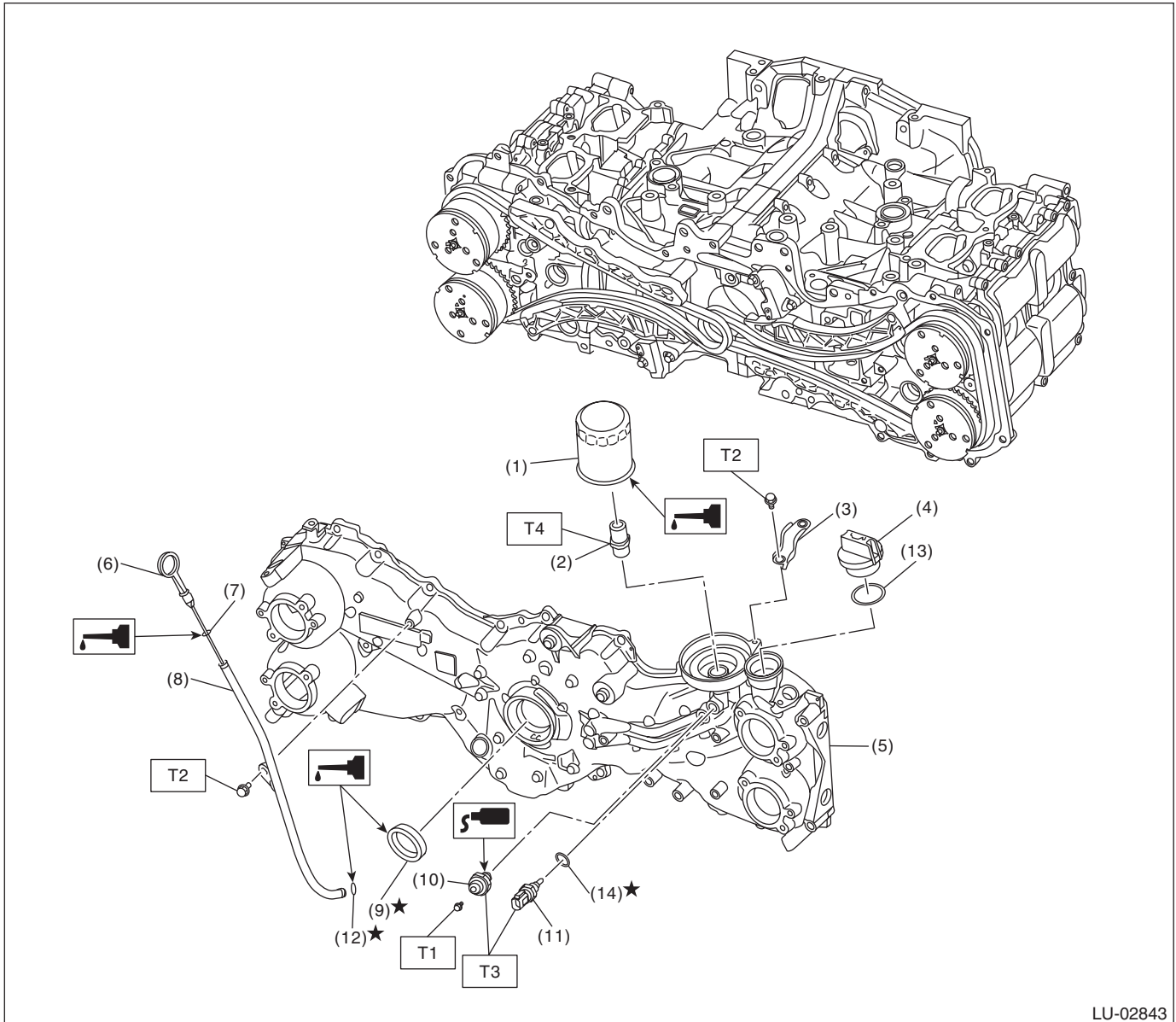

LU-02843

- | | |
|-------------------------|------------------------------------|
| (1) Oil filter | (8) Oil level gauge guide |
| (2) Oil pump union | (9) Front oil seal |
| (3) Generator cord stay | (10) Oil pressure switch |
| (4) Oil filler cap | (11) Engine oil temperature sensor |
| (5) Chain cover | (12) O-ring |
| (6) Oil level gauge | (13) O-ring |
| (7) O-ring | (14) Gasket |

Tightening torque: N·m (kgf·m, ft·lb)

T1: 1.5 (0.2, 1.1)

T2: 6.4 (0.7, 4.7)

T3: 18 (1.8, 13.3)

T4: 45 (4.6, 33.2)

General Description

LUBRICATION

C: CAUTION

- Prior to starting work, pay special attention to the following:
 1. Always wear work clothes, a safety cap, protective shoes. Additionally, wear a helmet, protective goggles, etc. if necessary.
 2. Protect the vehicle using a seat cover, fender cover, etc.
 3. Prepare the service tools, clean cloth, containers to catch grease and oil, etc.
- Prepare a container and cloth when performing work which oil possibly spills. If oil spills, wipe it off immediately to prevent from penetrating into floor or flowing out for environmental protection.
- Vehicle components are extremely hot immediately after driving. Be wary of receiving burns from heated parts.
- When performing a repair, identify the cause of trouble and avoid unnecessary removal, disassembly and replacement.
- Before disconnecting connectors of sensors or units, be sure to disconnect the ground cable from battery.
- Always use the jack-up point when the shop jacks or rigid racks are used to support the vehicle.
- Remove contamination including dirt and corrosion before removal, installation, disassembly or assembly.
- Keep the removed parts in order and protect them from dust and dirt.
- All removed parts, if to be reused, should be reinstalled in the original positions with attention to the correct directions, etc.
- Bolts, nuts and washers should be replaced with new parts as required.
- Be sure to tighten the fasteners including bolts and nuts to the specified torque.
- If the engine oil is spilt over exhaust pipe or the under cover, wipe it off with cloth to avoid emitting smoke or causing a fire.
- Follow all government and local regulations concerning disposal of refuse when disposing of oil.

D: PREPARATION TOOL

1. SPECIAL TOOL

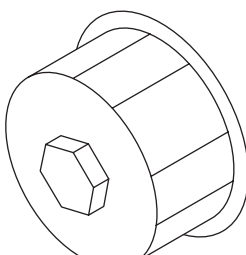
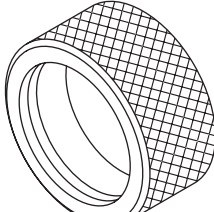
ILLUSTRATION	TOOL NUMBER	DESCRIPTION	REMARKS
 <p style="text-align: center;">ST18332AA000</p>	18332AA000	OIL FILTER WRENCH	Used for removing and installing oil filter (Black). (outer diameter: 68 mm (2.68 in))
 <p style="text-align: center;">ST-398437700</p>	398437700	OIL SEAL INSTALLER	Used for installing the front oil seal.

2. GENERAL TOOL

TOOL NAME	REMARKS
Oil filter wrench (65/67 mm 14 Flutes)	Used for removing and installing oil filter (Blue). (outer diameter: 67.4 mm (2.65 in))
Circuit tester	Used for measuring resistance and voltage.