

2. Starter

A: REMOVAL

- 1) Disconnect the ground cable from battery.

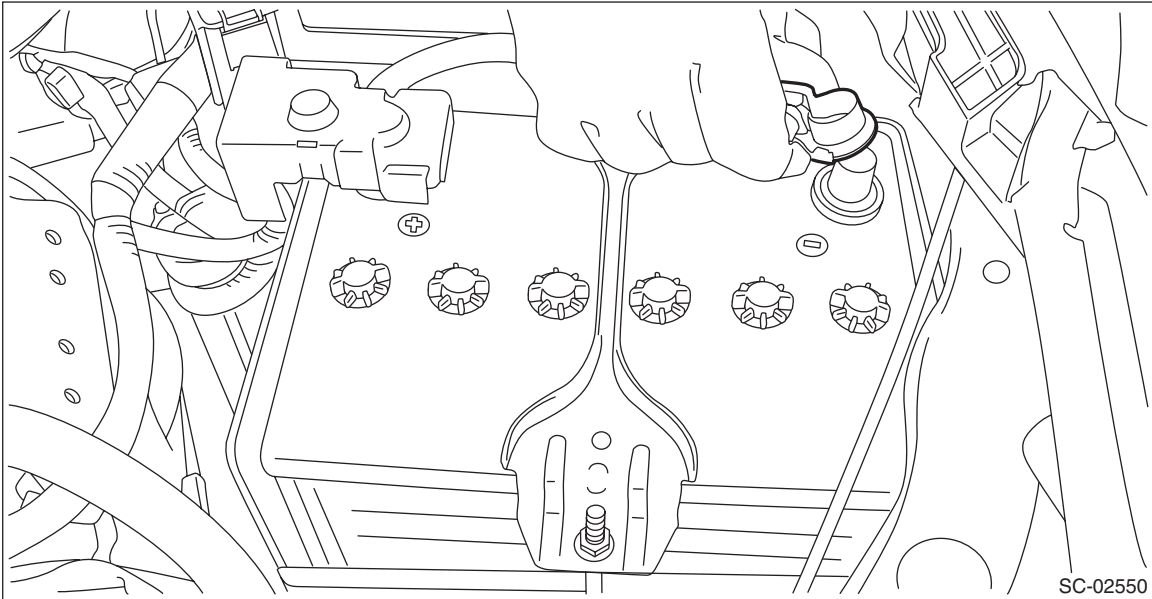

- 2) Remove the clip (A) from the air intake boot.
- 3) Loosen the clamp (B) connecting the air intake boot and air cleaner case (rear).
- 4) Loosen the clamp (C) which connects the air intake boot and throttle body.

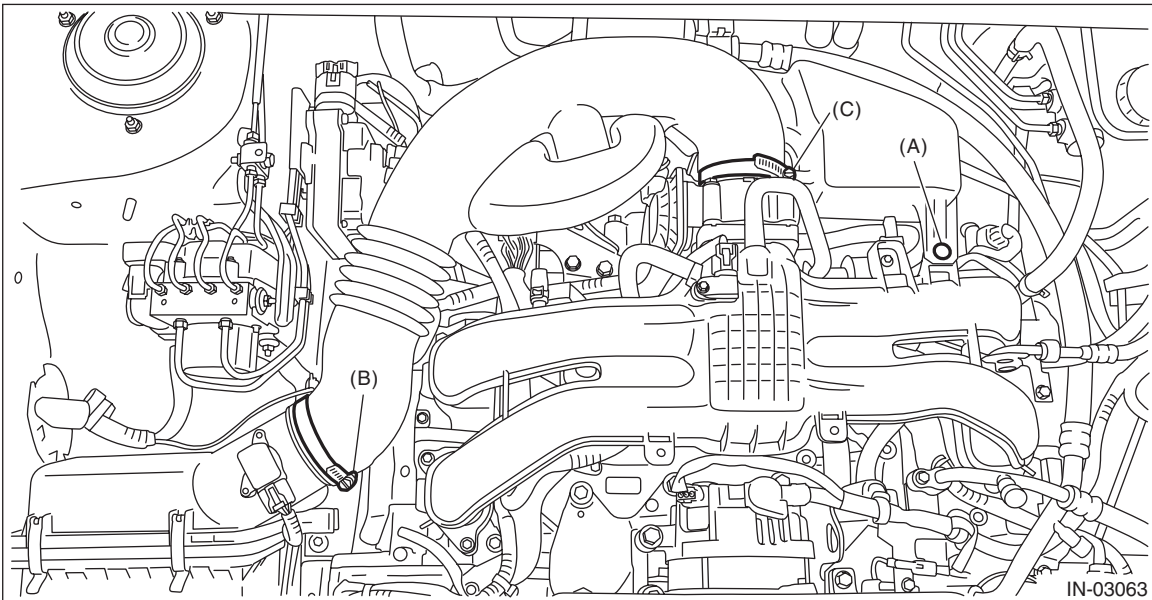

Starter

STARTING/CHARGING SYSTEMS

- 5) Remove the air intake boot from the throttle body, and move the air intake boot to the left side wheel apron.

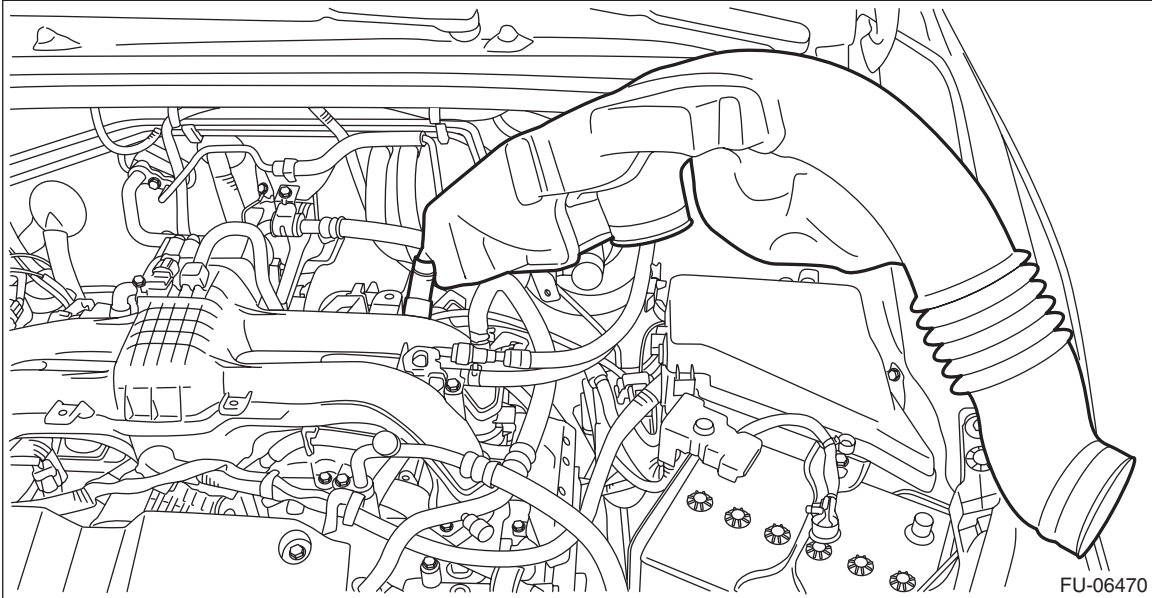

- 6) Disconnect the connector (B) and terminal (A) from starter.

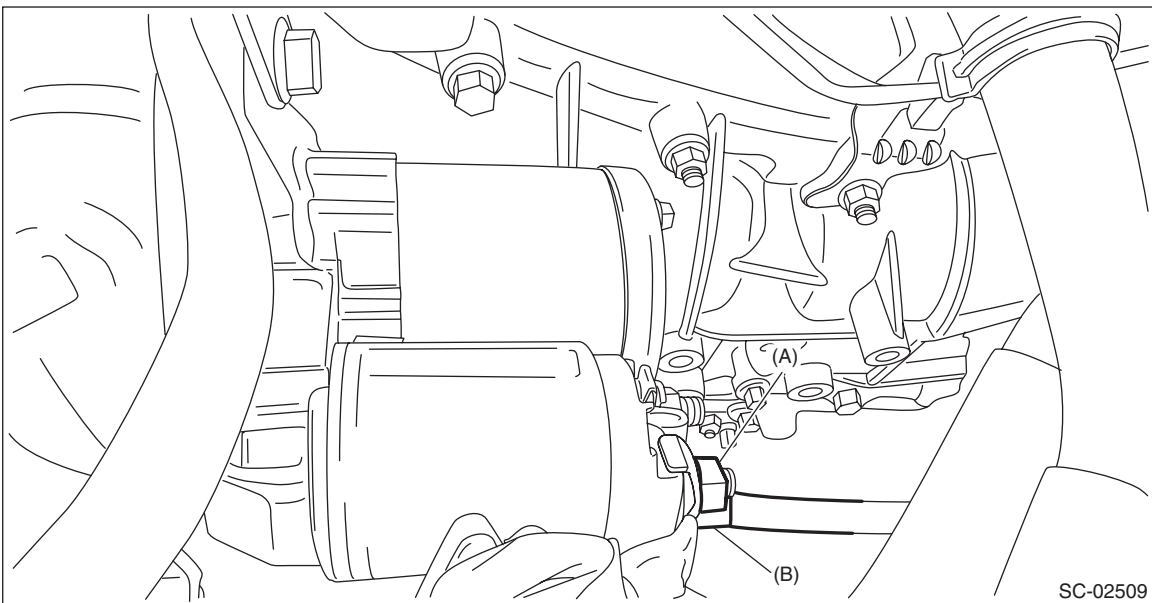

Starter

7) Remove the starter from transmission.

NOTE:

For CVT model, a nut is used at (A).

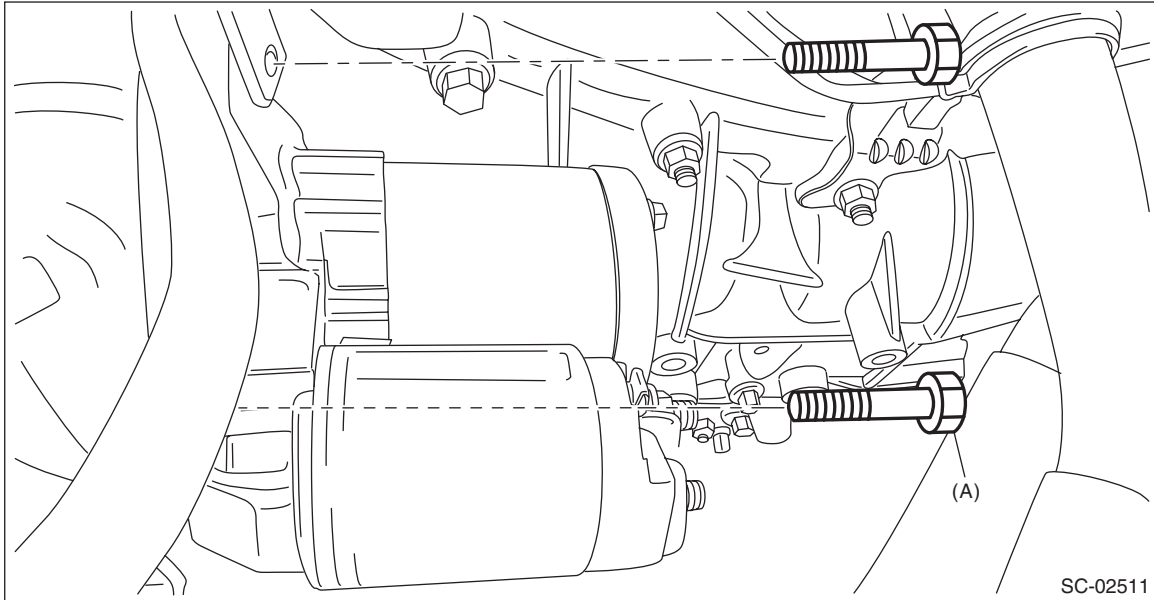

SC-02511

Starter

STARTING/CHARGING SYSTEMS

B: INSTALLATION

Install in the reverse order of removal.

NOTE:

For CVT model, a nut is used at (A).

Tightening torque:

50 N·m (5.1 kgf-m, 36.9 ft-lb)

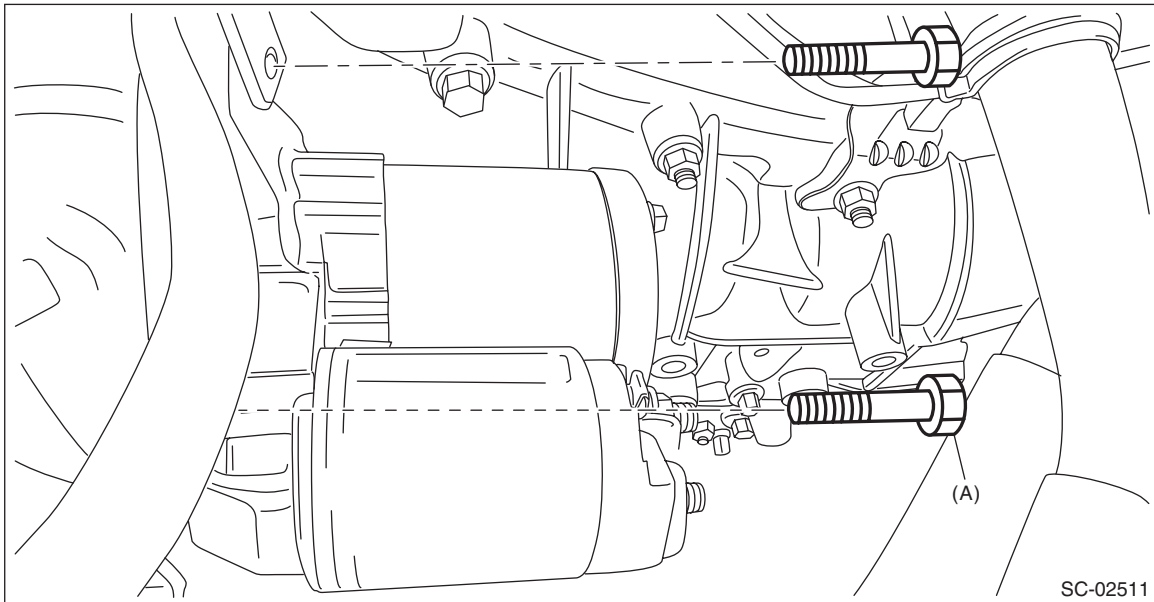

Tightening torque:

10 N·m (1.0 kgf-m, 7.4 ft-lb)

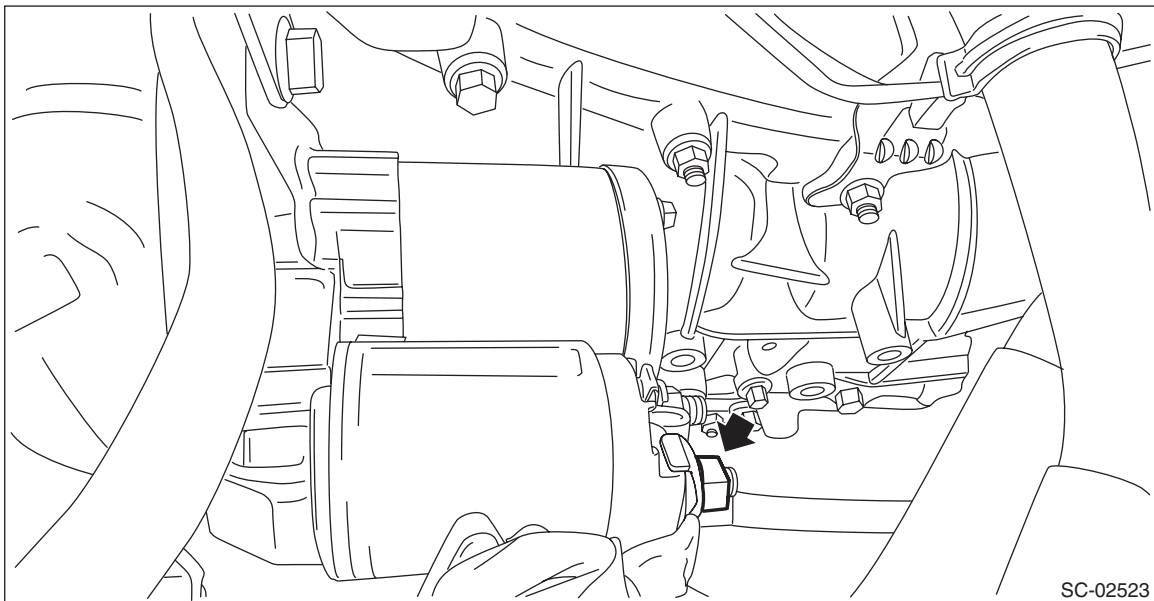

C: DISASSEMBLY

- 1) Disconnect the terminal M from the magnet switch assembly.

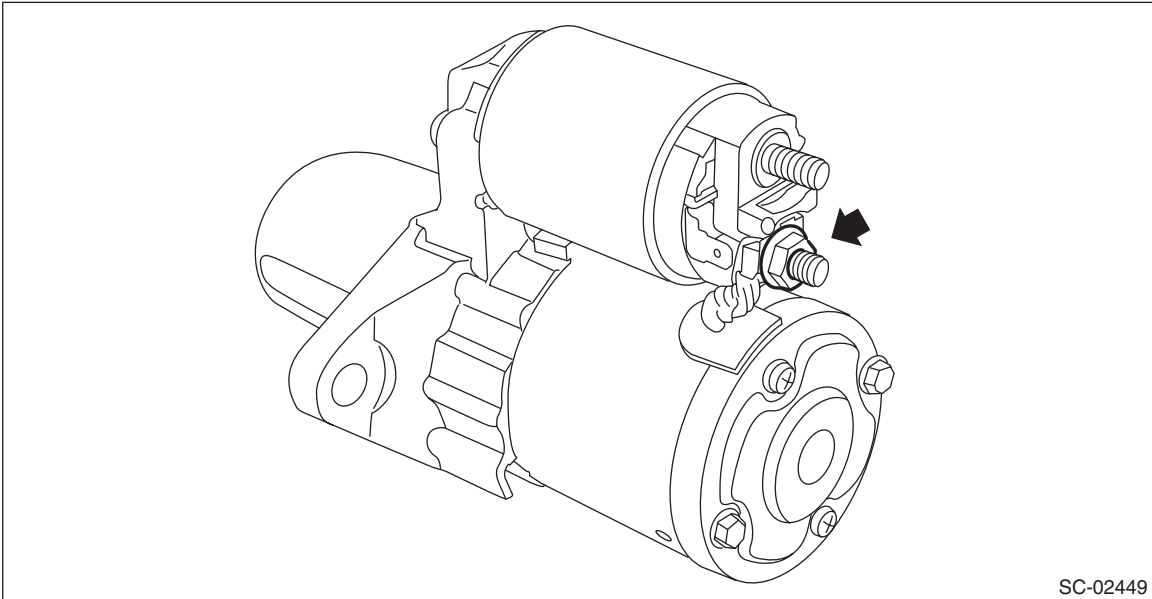

- 2) Remove the magnet switch assembly from the starter housing assembly.

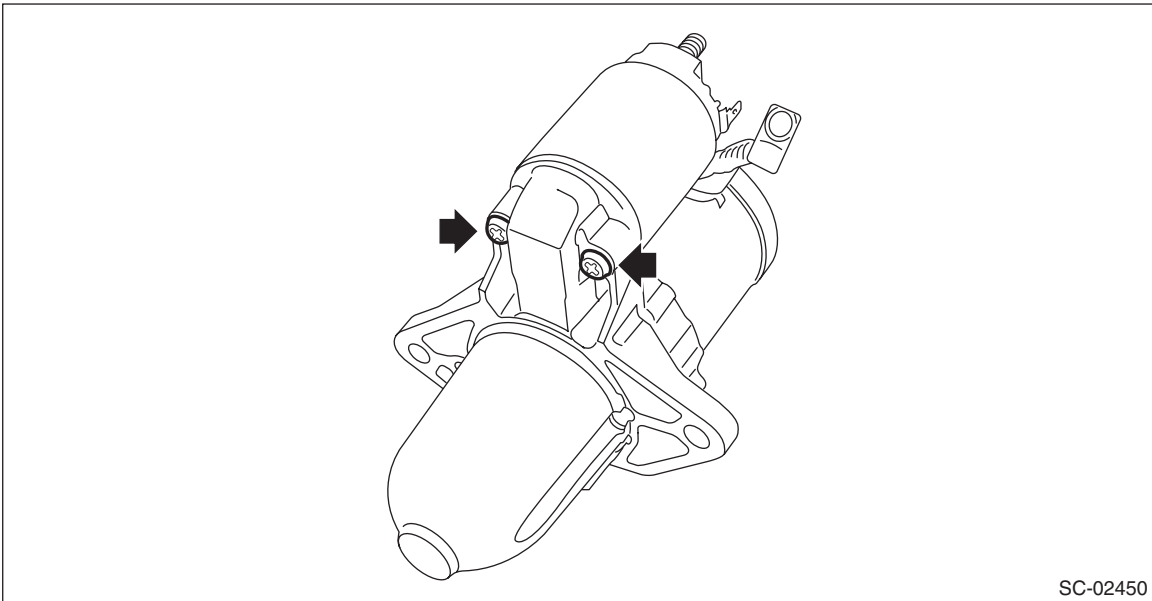

Starter

STARTING/CHARGING SYSTEMS

3) Remove screws (A) of the brush holder assembly, and through bolts (B) on both sides, and remove the starter cover assembly.

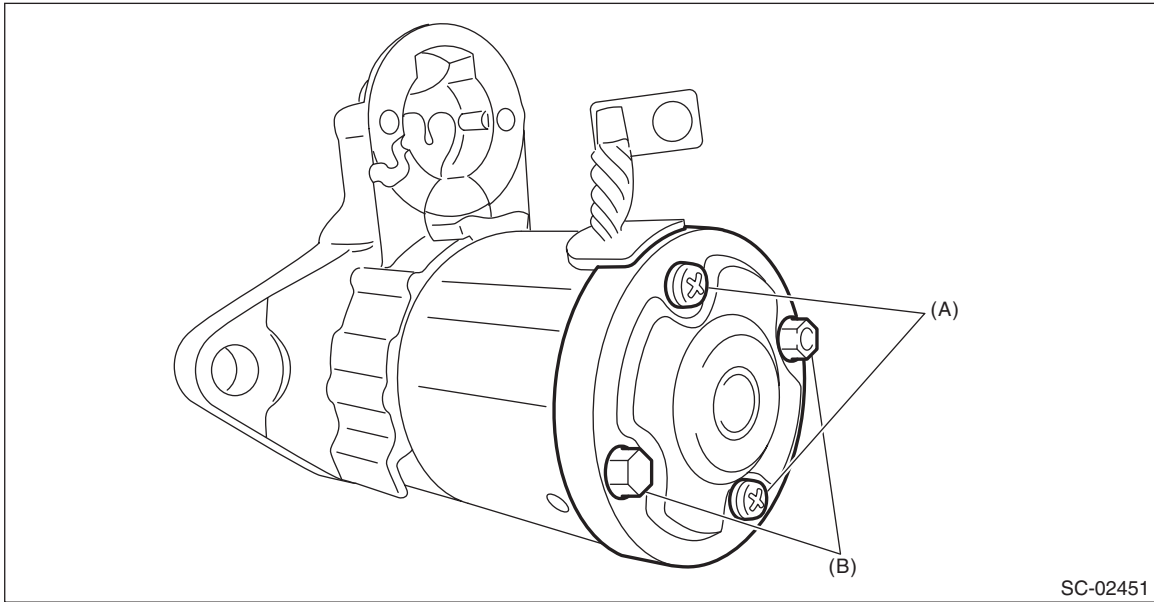

4) Remove the brush holder assembly from the armature assembly.

NOTE:

Hold the brush with your fingers so that the brush spring does not come flying out.

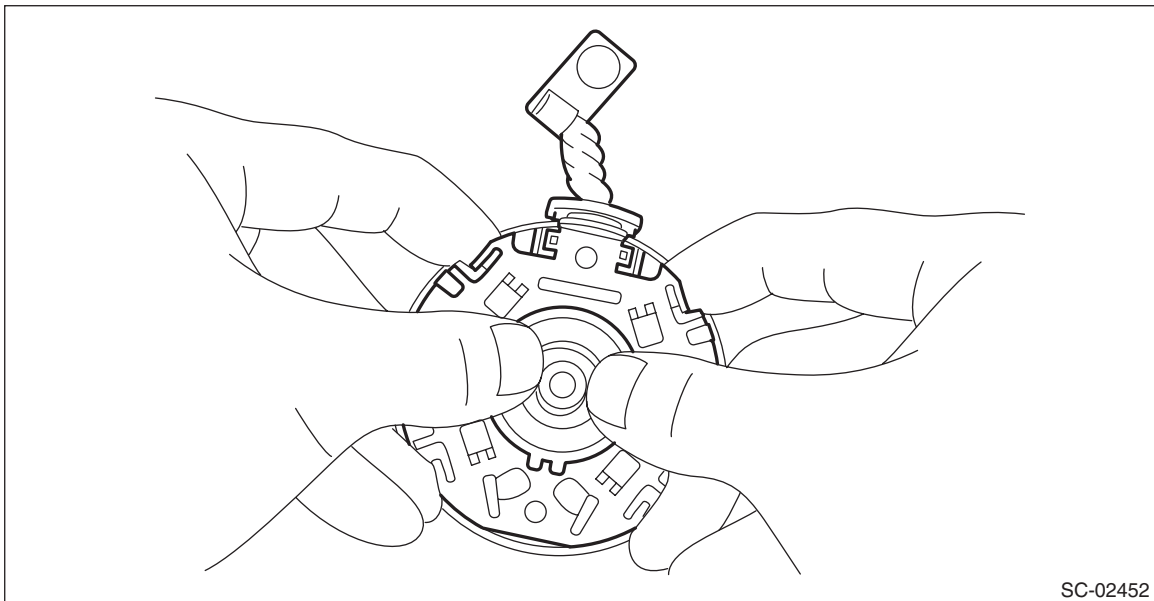

- 5) Remove the armature assembly and yoke assembly from the starter housing assembly together as a single unit.

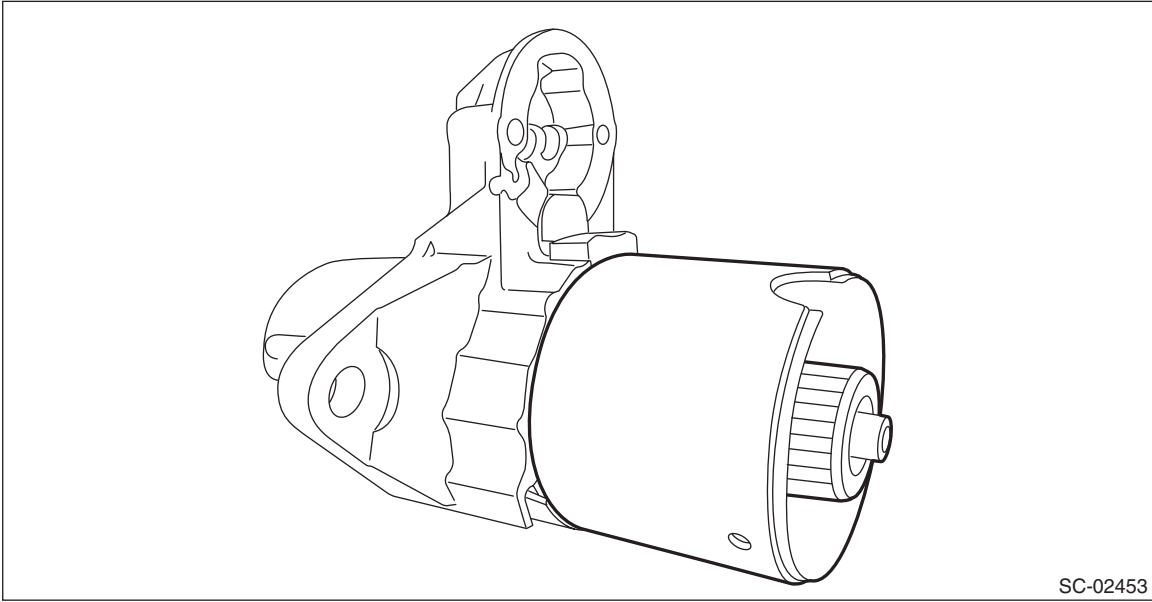

- 6) Separate the armature assembly and yoke assembly.

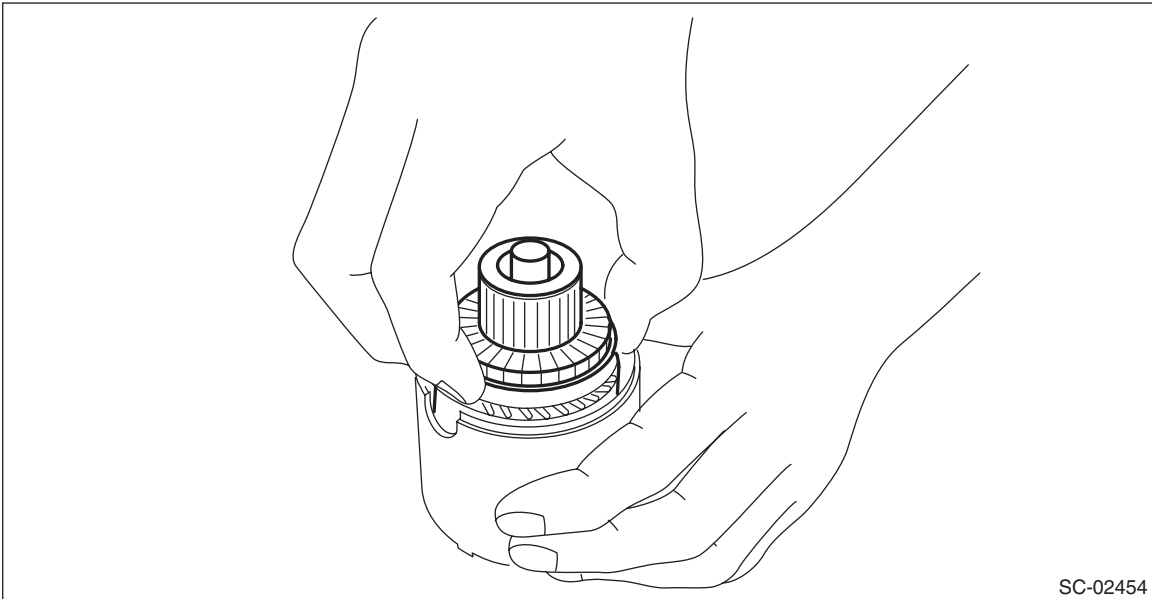

Starter

STARTING/CHARGING SYSTEMS

7) Remove the pinion gear from the internal gear assembly.

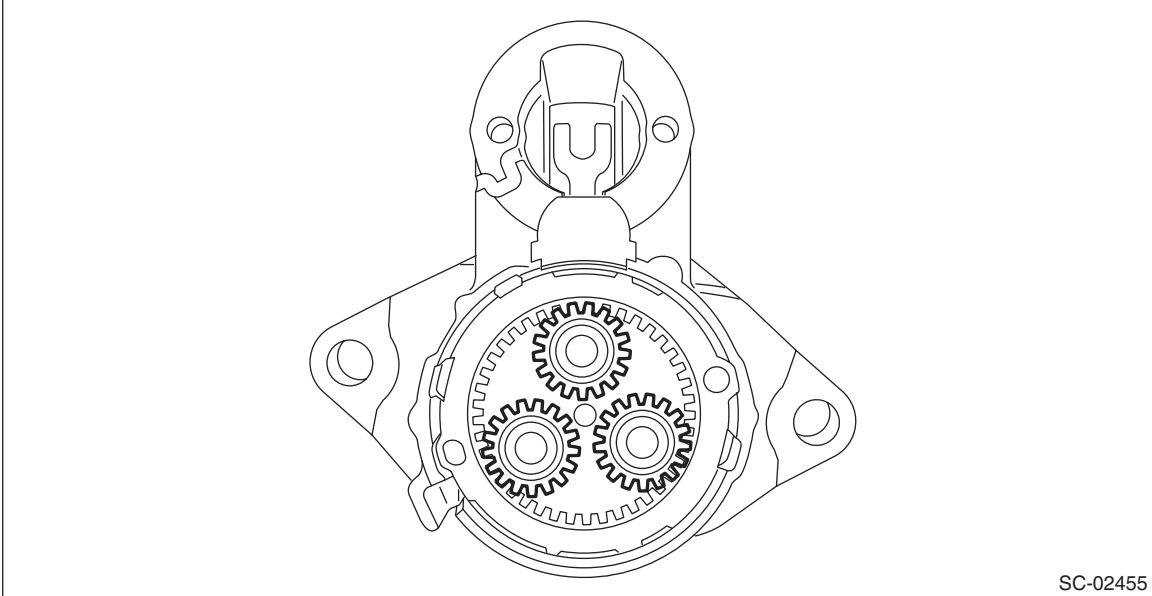

SC-02455

8) Remove seal rubber (A), plate (B), and seal rubber (C).

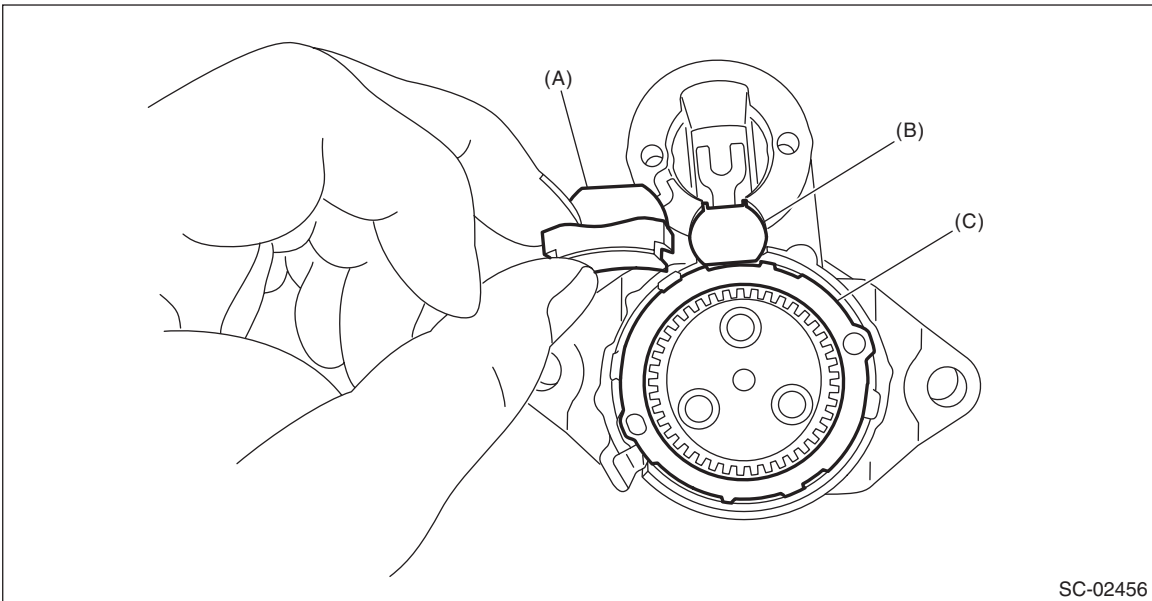

SC-02456

9) Lightly tap the starter housing assembly with a plastic hammer as shown in the figure, and remove the overrunning clutch, internal gear assembly, shaft and shift lever together as one unit.

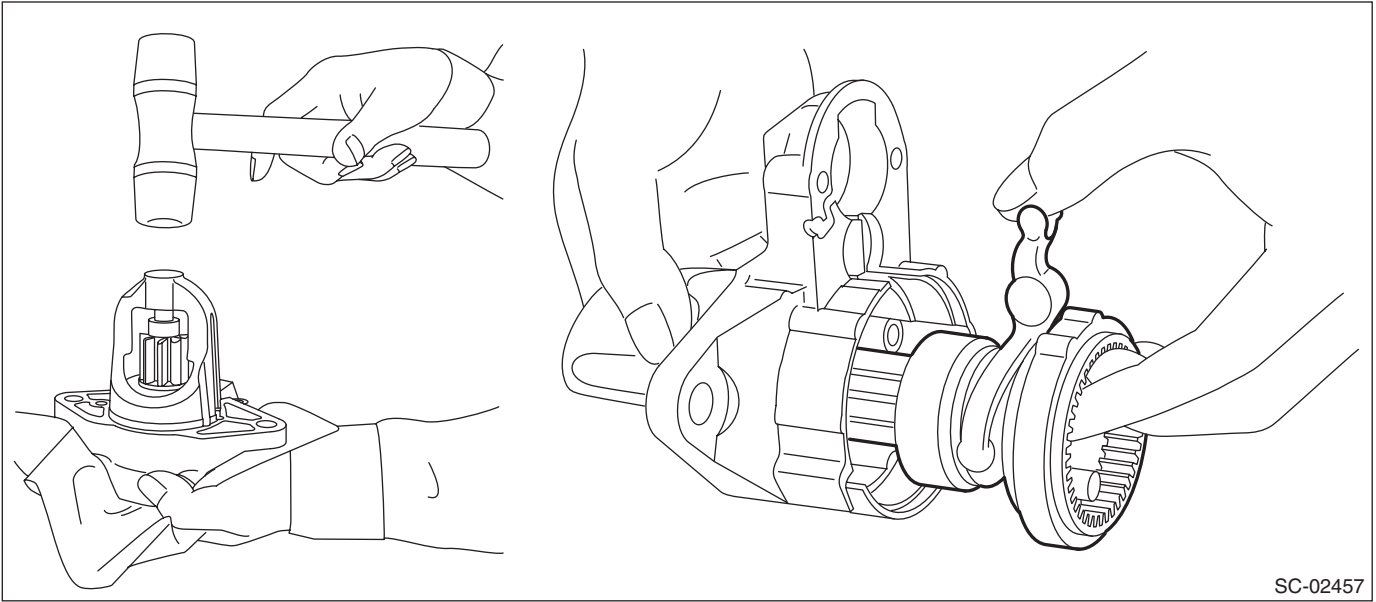

10) Use the following procedures to remove the overrunning clutch from the shaft.

(1) Use an appropriate tool (such as a fit socket wrench), and remove the stopper from snap ring by lightly tapping the stopper with a plastic hammer.

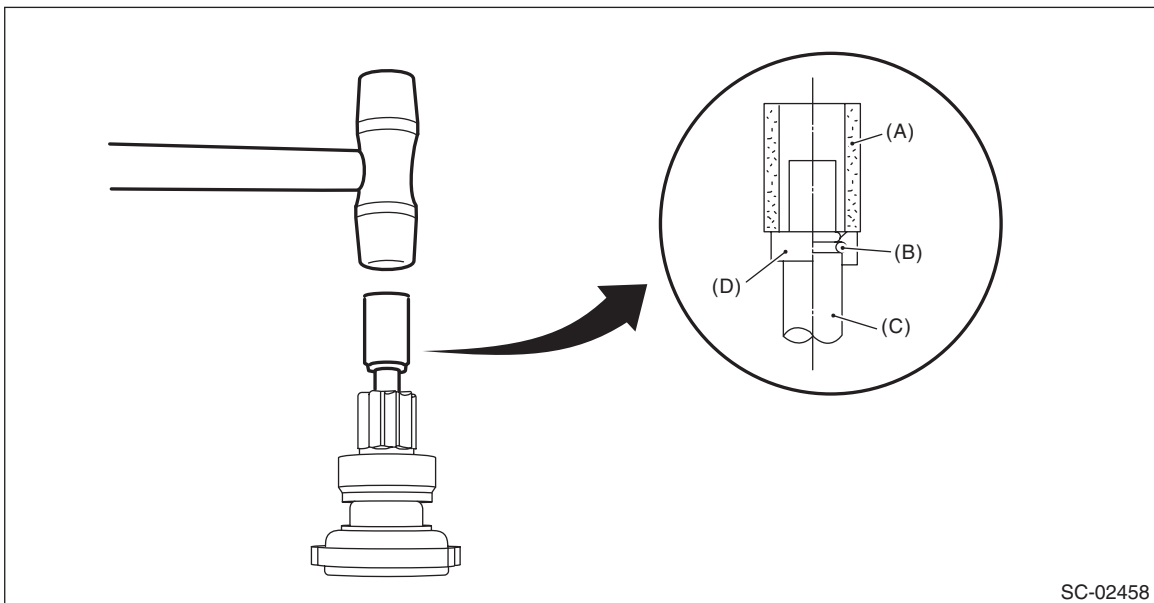

(A) Appropriate tool
(D) Stopper

(B) Snap ring

(C) Shaft

Starter

STARTING/CHARGING SYSTEMS

- (2) Remove snap ring (A) from the shaft, and remove stopper (B).

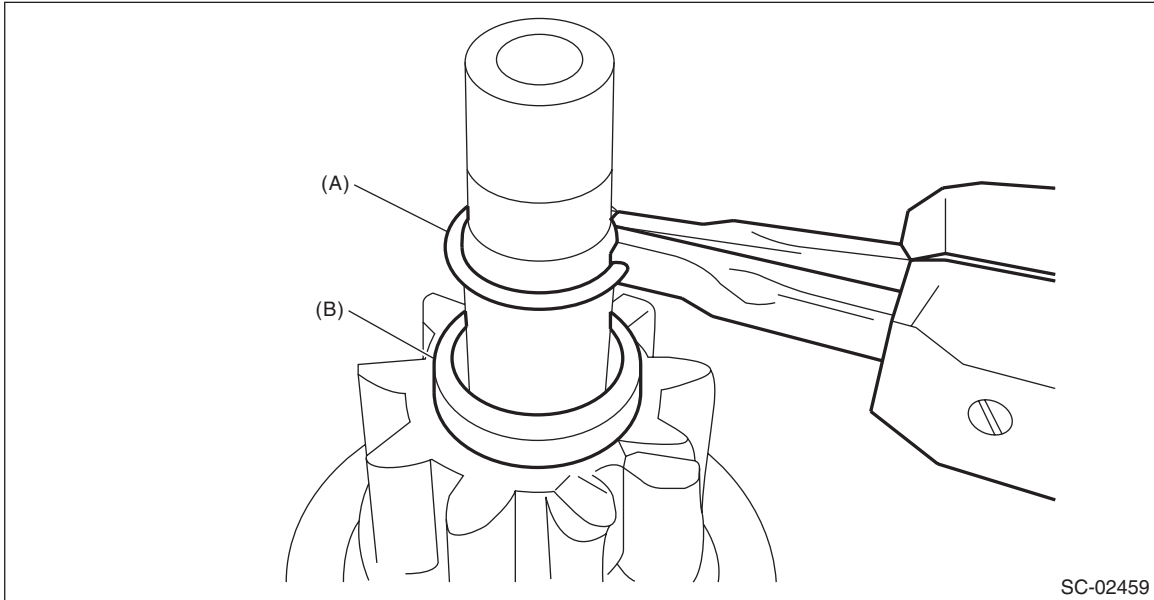

- (3) Remove the overrunning clutch from the shaft.

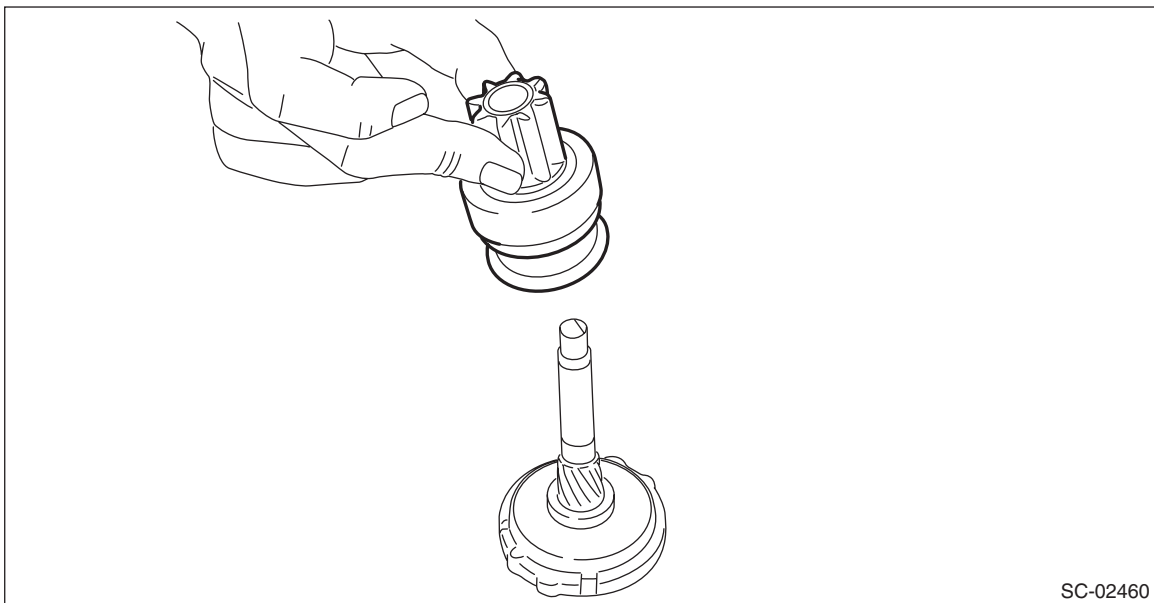

11) Separate the internal gear assembly and shaft.

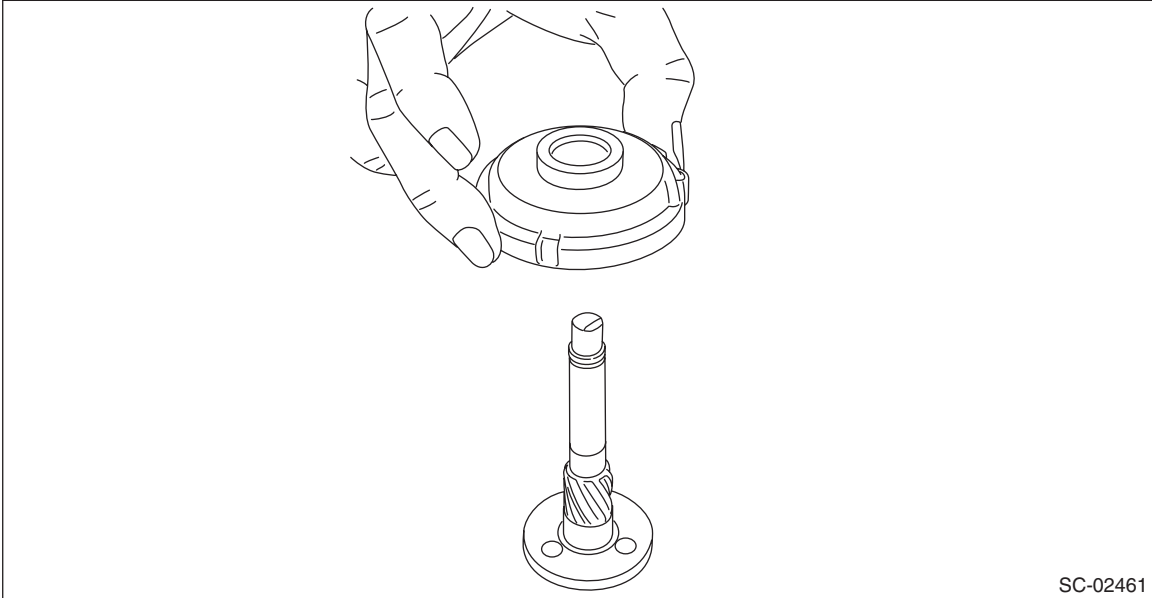

Starter

STARTING/CHARGING SYSTEMS

D: ASSEMBLY

1) Apply grease to the shaft sliding surfaces of the internal gear assembly.

Grease:

Multemp #6129 or equivalent

2) Assemble the shaft to the internal gear assembly.

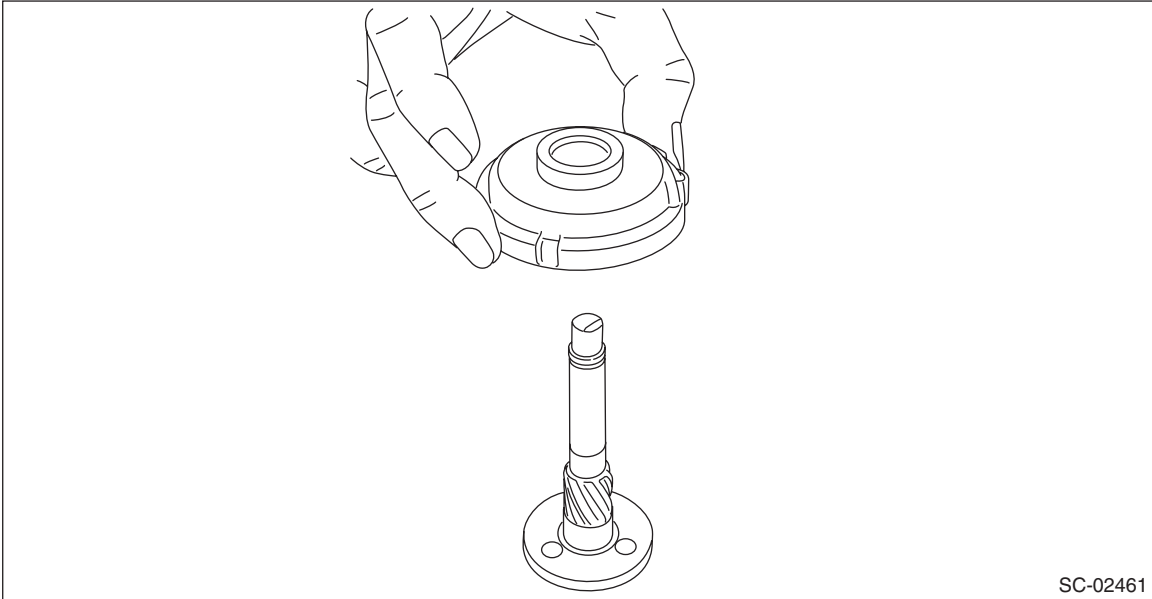

3) Assemble the overrunning clutch as follows:

(1) Apply grease to the spline portion of the shaft.

Grease:

Multemp #6129 or equivalent

(2) Install the overrunning clutch to shaft.

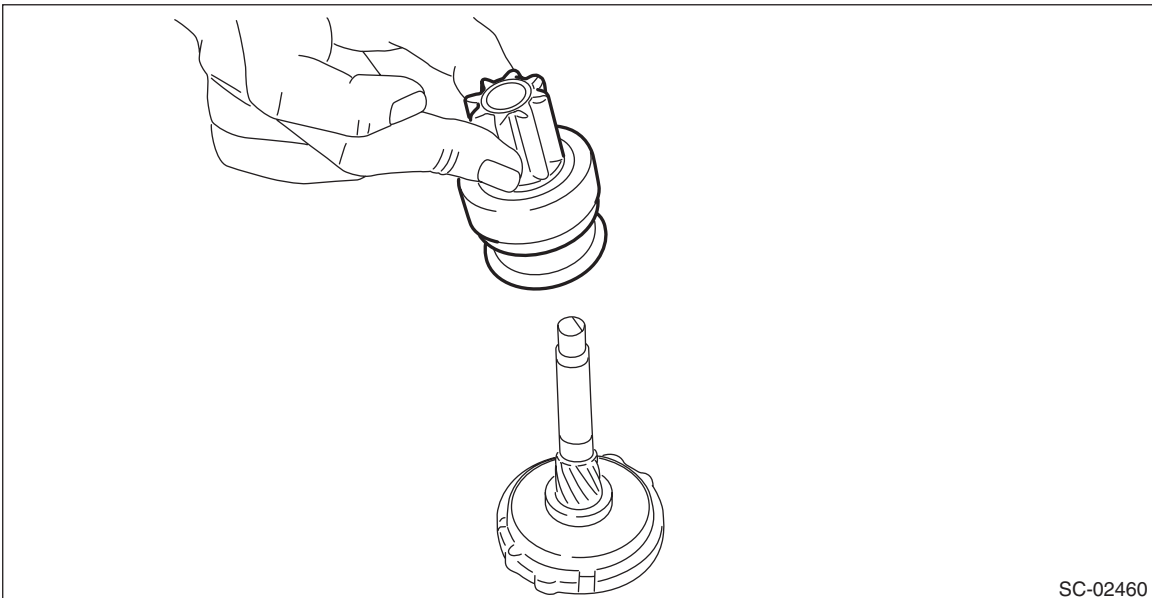

(3) Pass stopper (B) through the shaft assembly, and attach snap ring (A).

NOTE:

Use new stoppers and snap rings.

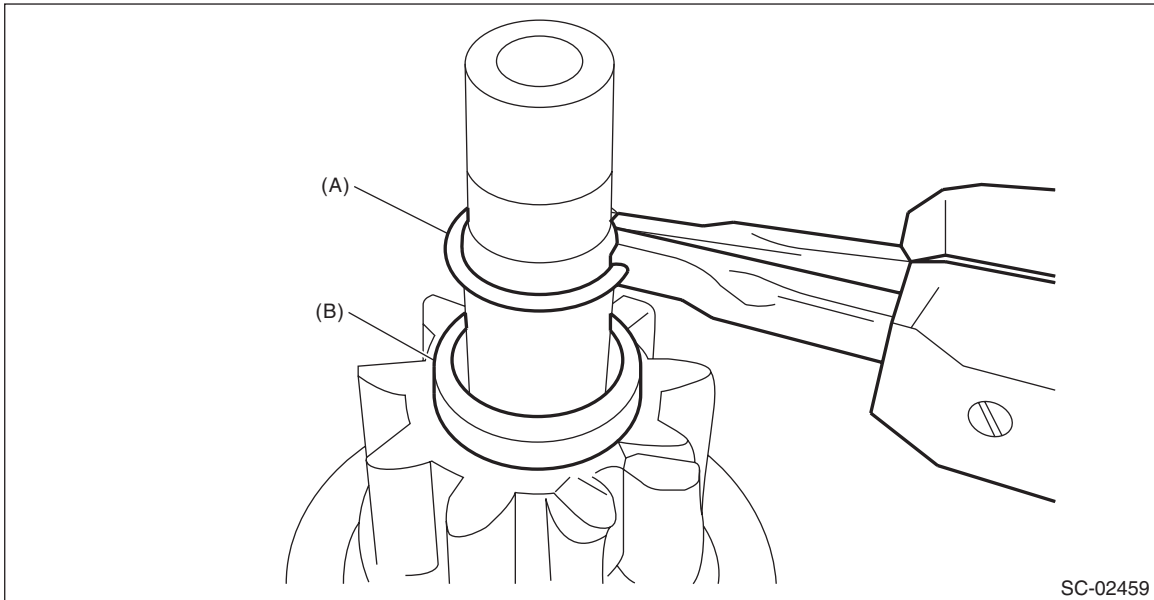

(4) Using a press, pressure fit stopper (B) into snap ring (A).

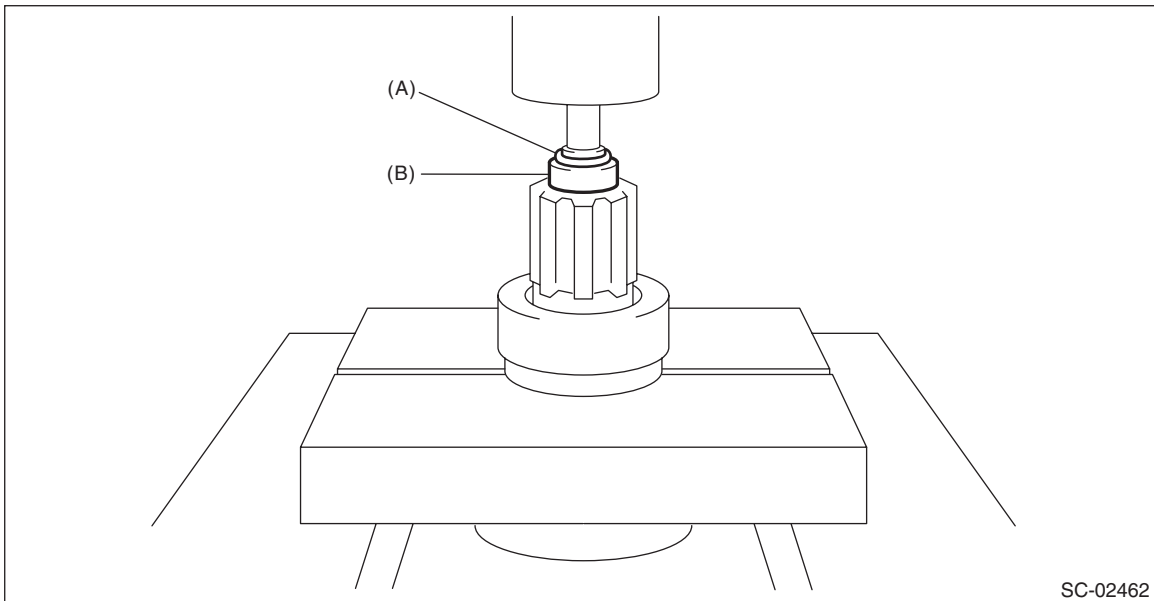

Starter

STARTING/CHARGING SYSTEMS

4) Assemble the overrunning clutch, internal gear assembly, shaft and shift lever as a single unit into the starter housing assembly.

NOTE:

Apply grease to the moving parts of the shift lever.

Grease:

Multemp #6129 or equivalent

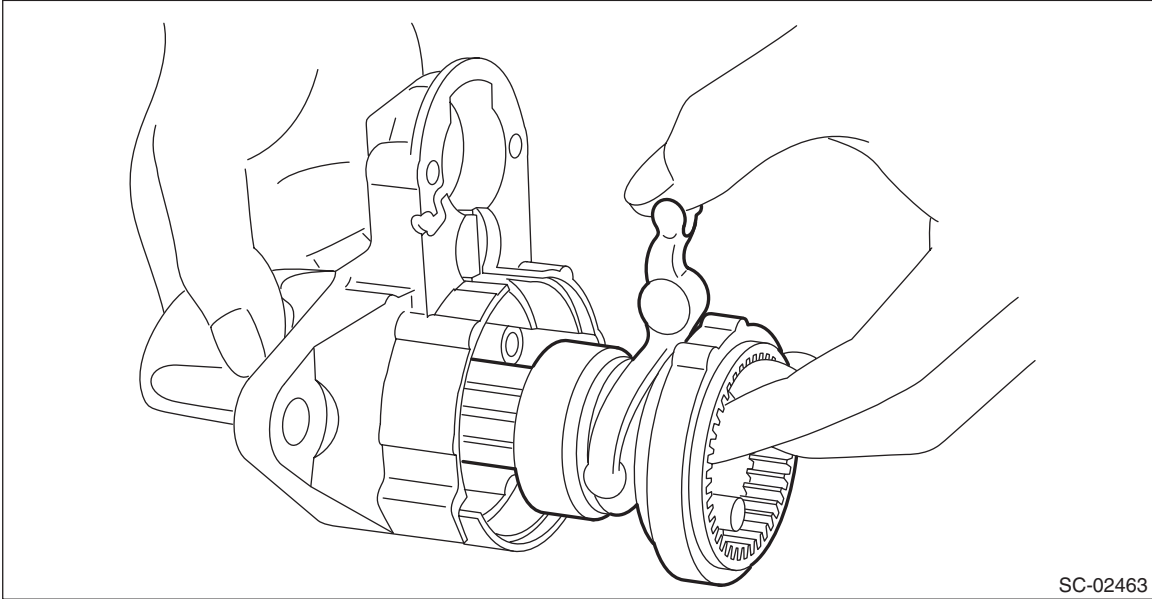

5) Apply grease to the inside of the internal gear assembly and pinion gear, and attach the pinion gear to the internal gear assembly.

NOTE:

- Apply grease evenly to the contact surfaces of each gear.
- Be careful that no debris becomes attached.

Grease:

Molykote® AG650 or equivalent

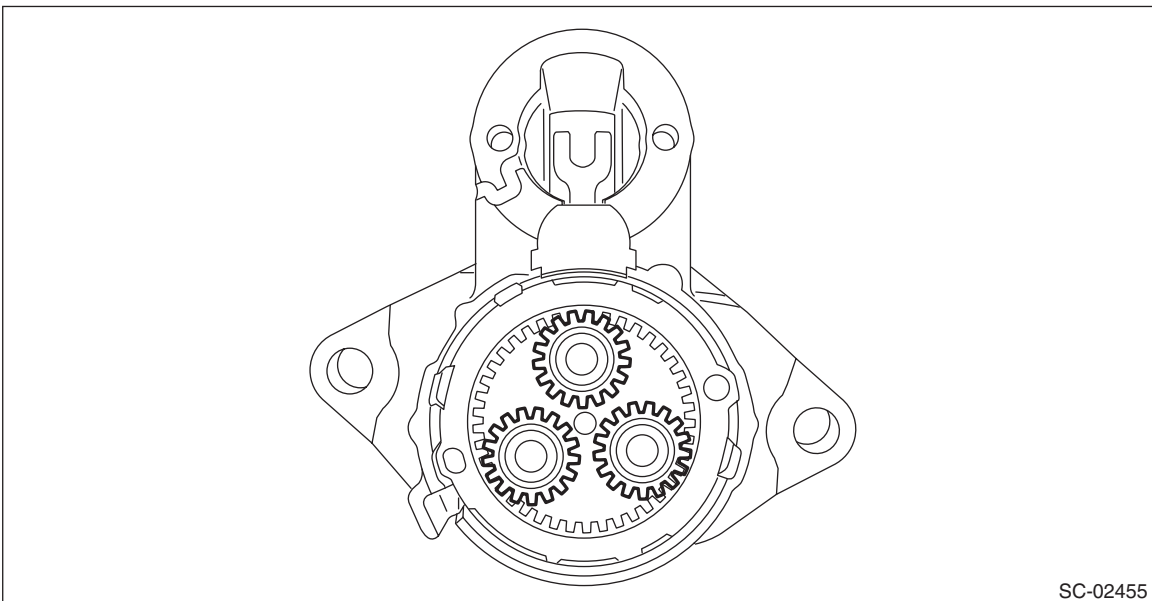

6) Install seal rubber (A), plate (B), and seal rubber (C).

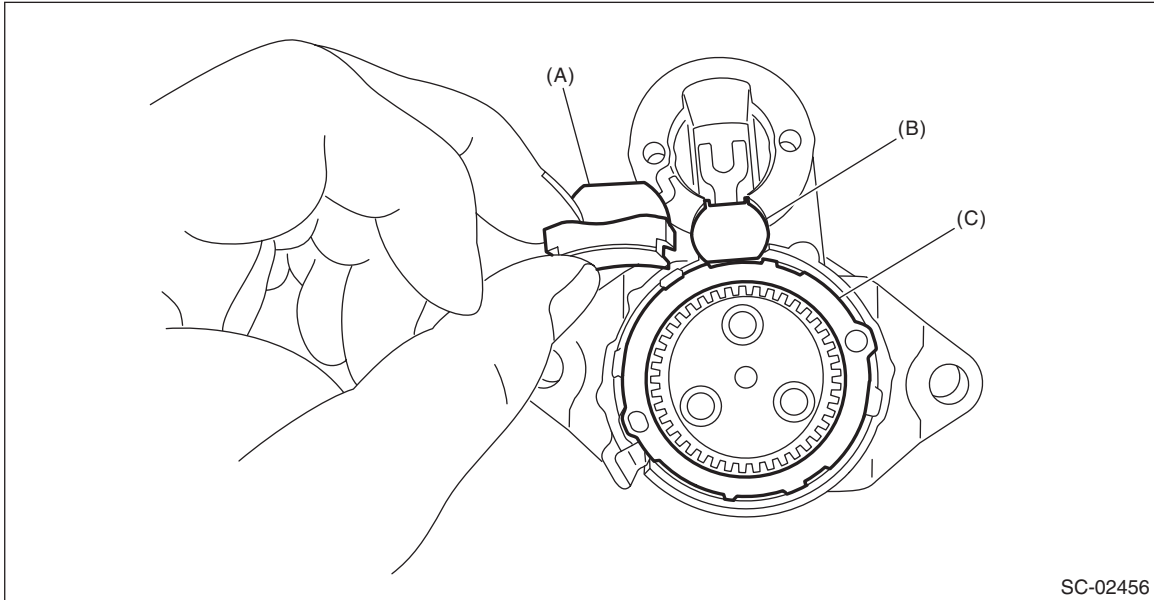

7) Assemble the armature assembly to the yoke assembly.

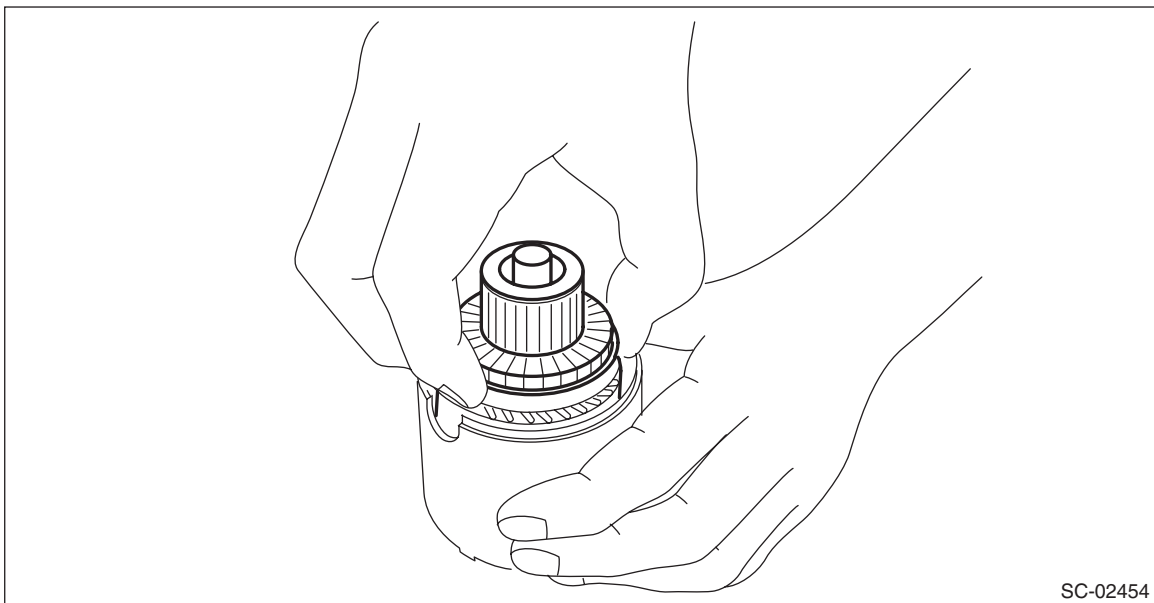

Starter

STARTING/CHARGING SYSTEMS

8) Attach the armature assembly and yoke assembly to the starter housing assembly together as a single unit.

NOTE:

As shown in the figure, match the protrusion of the yoke assembly to the cut out of the starter housing assembly.

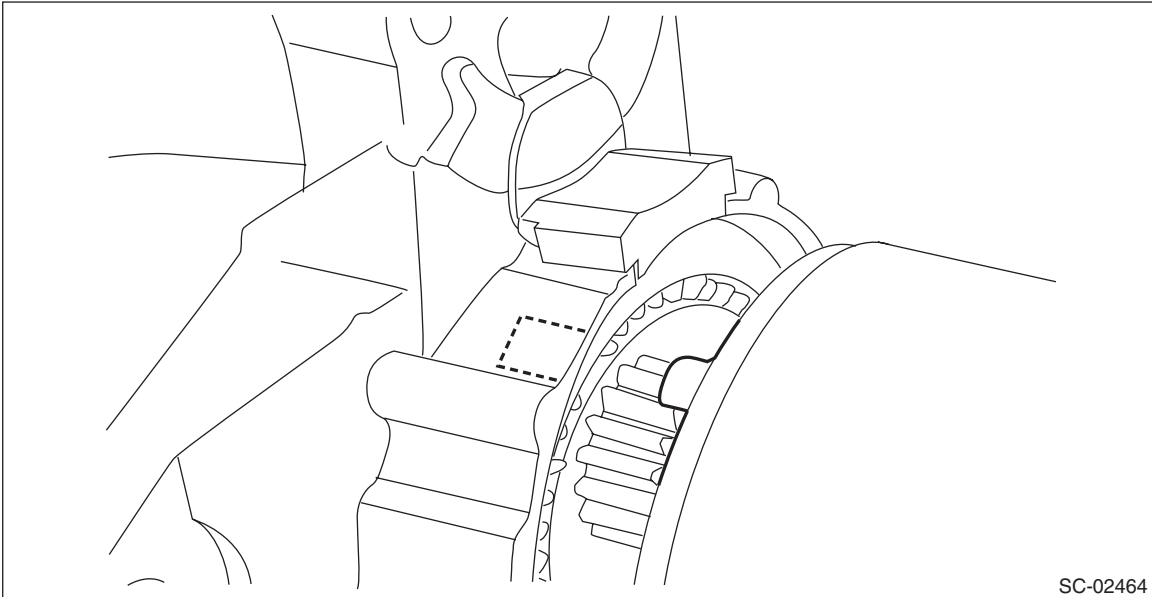

SC-02464

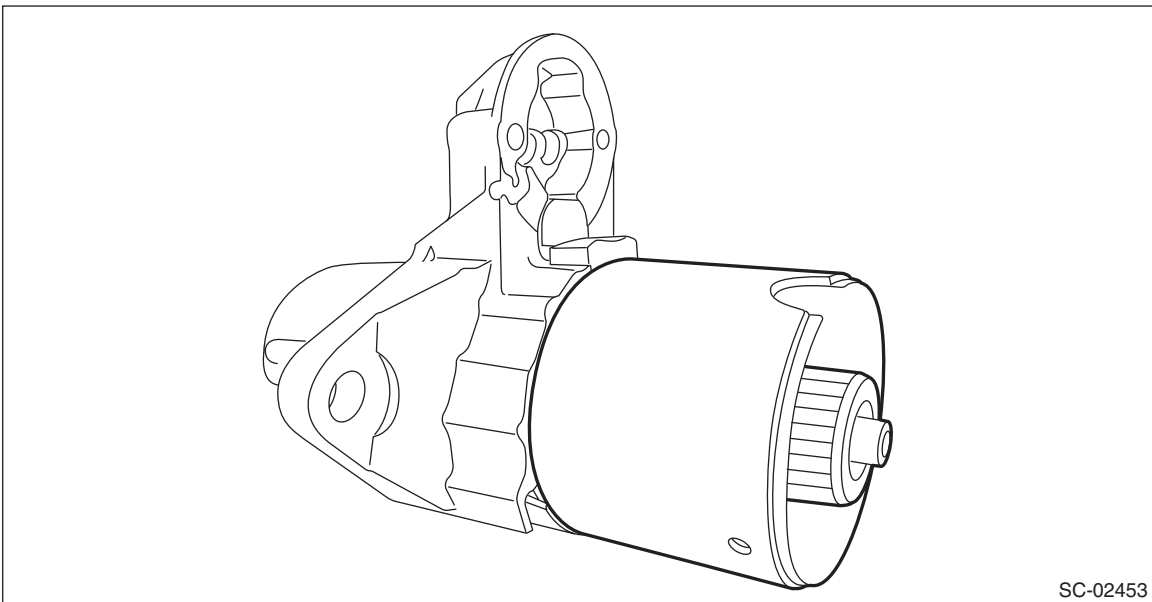

SC-02453

9) Use an appropriate tool (such as correctly sized socket wrenches) and attach the brush holder assembly to the armature assembly.

NOTE:

Be careful not to damage the brushes.

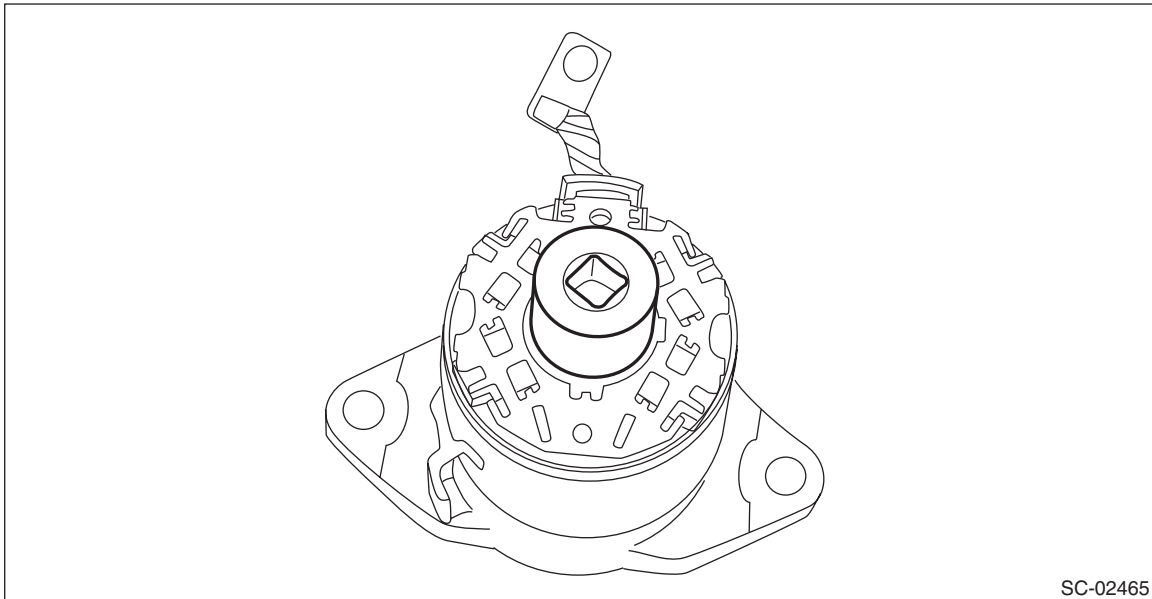

SC-02465

10) Secure starter cover assembly to the brush holder assembly with screws (A).

Tightening torque:

1.4 N·m (0.1 kgf-m, 1.0 ft-lb)

11) Tighten through bolts (B) on both sides.

Tightening torque:

6 N·m (0.6 kgf-m, 4.4 ft-lb)

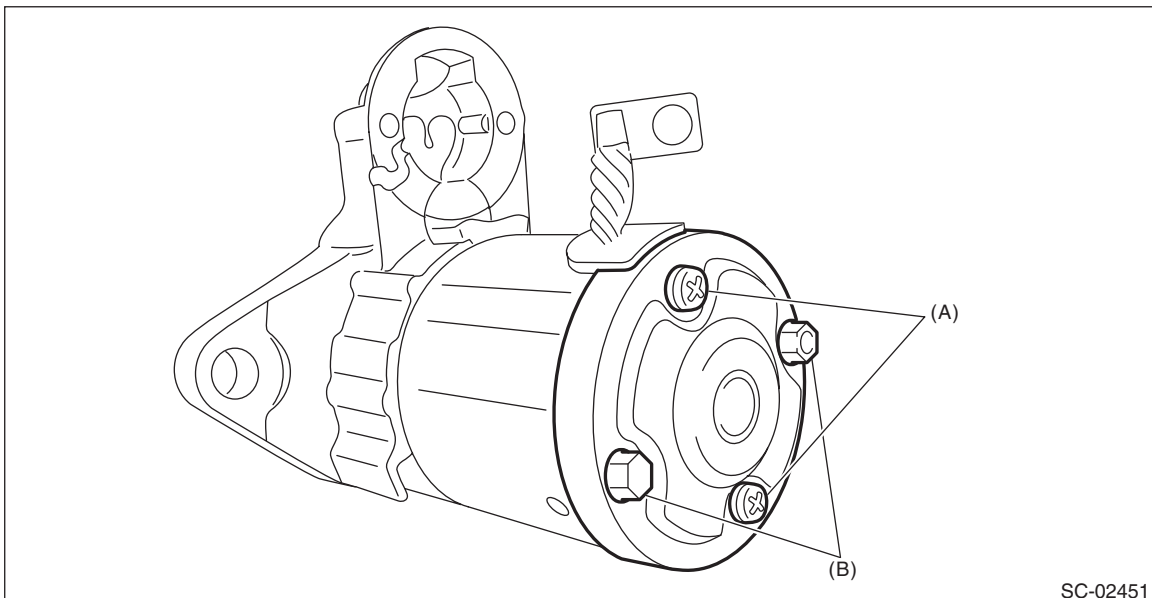

SC-02451

Starter

STARTING/CHARGING SYSTEMS

12) Attach the magnet switch assembly to the starter housing assembly.

Tightening torque:

7.5 N·m (0.8 kgf-m, 5.5 ft-lb)

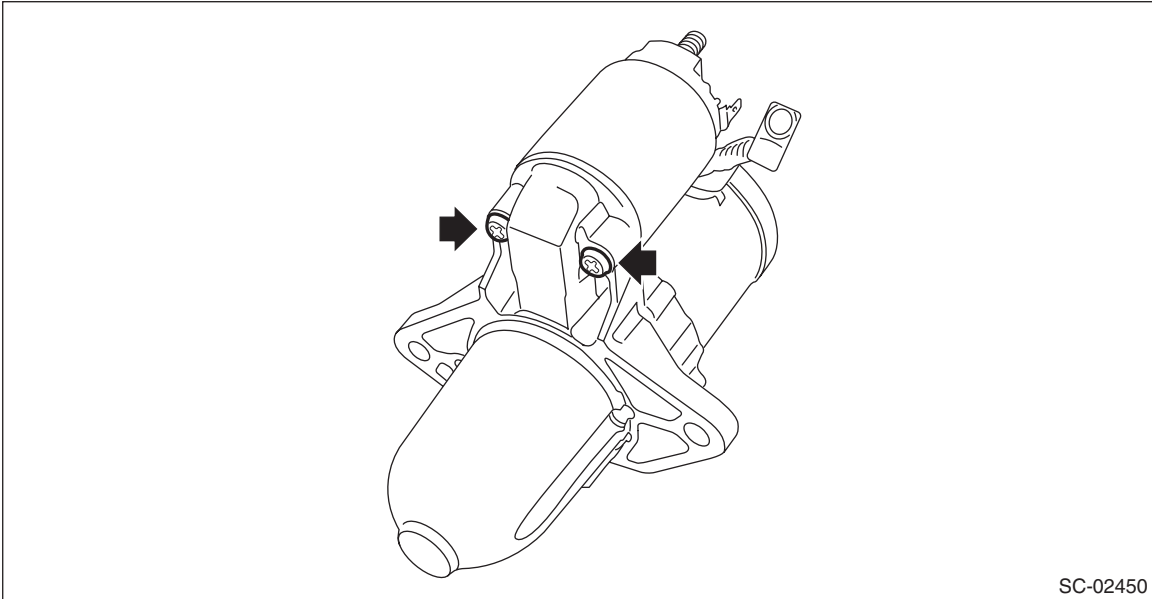

SC-02450

13) Attach the cable to the terminal M of the magnet switch assembly, and secure with nuts.

Tightening torque:

10 N·m (1.0 kgf-m, 7.4 ft-lb)

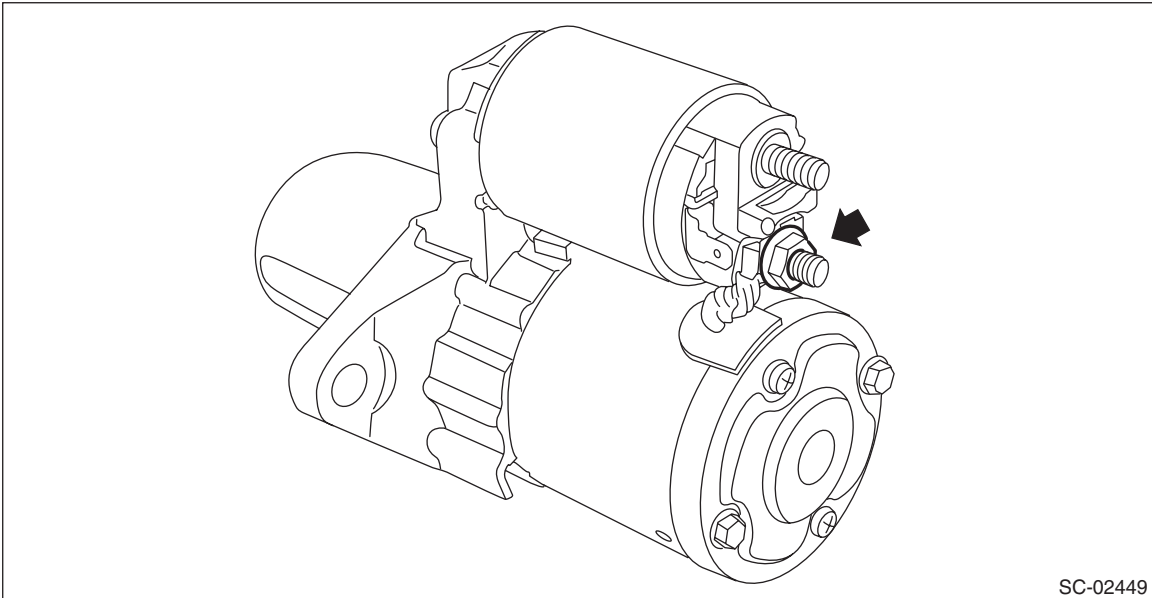

SC-02449

E: INSPECTION

1. ARMATURE

- 1) Check the commutator for signs of seizure or stepped wear caused by roughness of the surface. If there is light wear, use sandpaper to repair.
- 2) Check for runout on the commutator. If excessive, replace the armature.

Commutator runout:

Standard

0.05 mm (0.0020 in)

Limit

0.10 mm (0.0039 in)

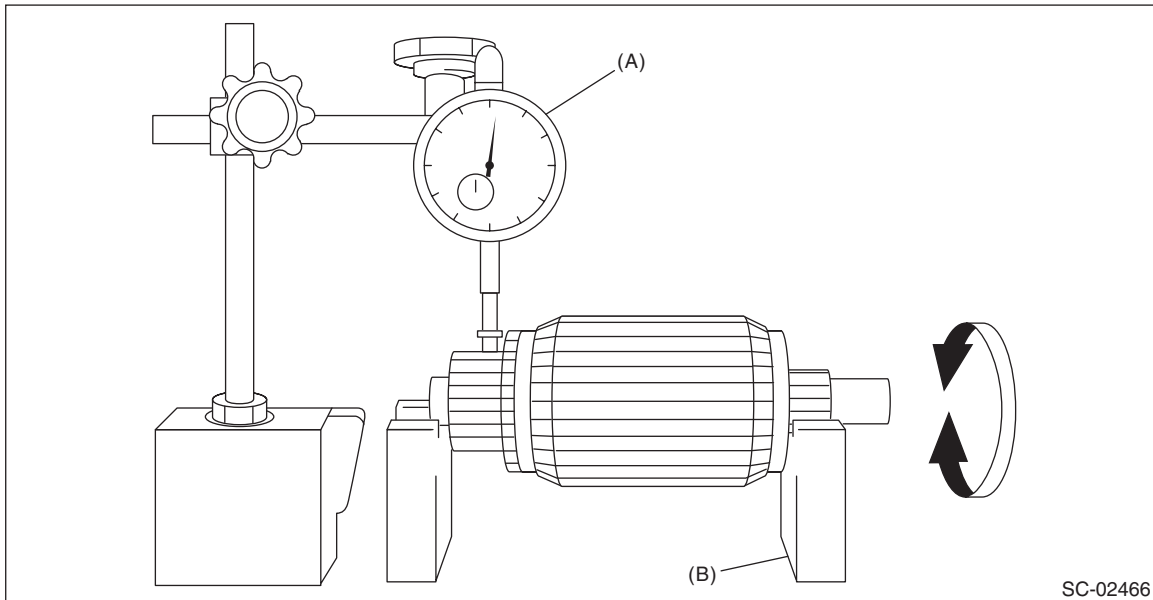

(A) Dial gauge

(B) V-block

Starter

STARTING/CHARGING SYSTEMS

3) Check the depth of the segment mold. If it is not within the standard, replace the armature.

Depth of segment mold:

Standard

0.50 mm (0.020 in)

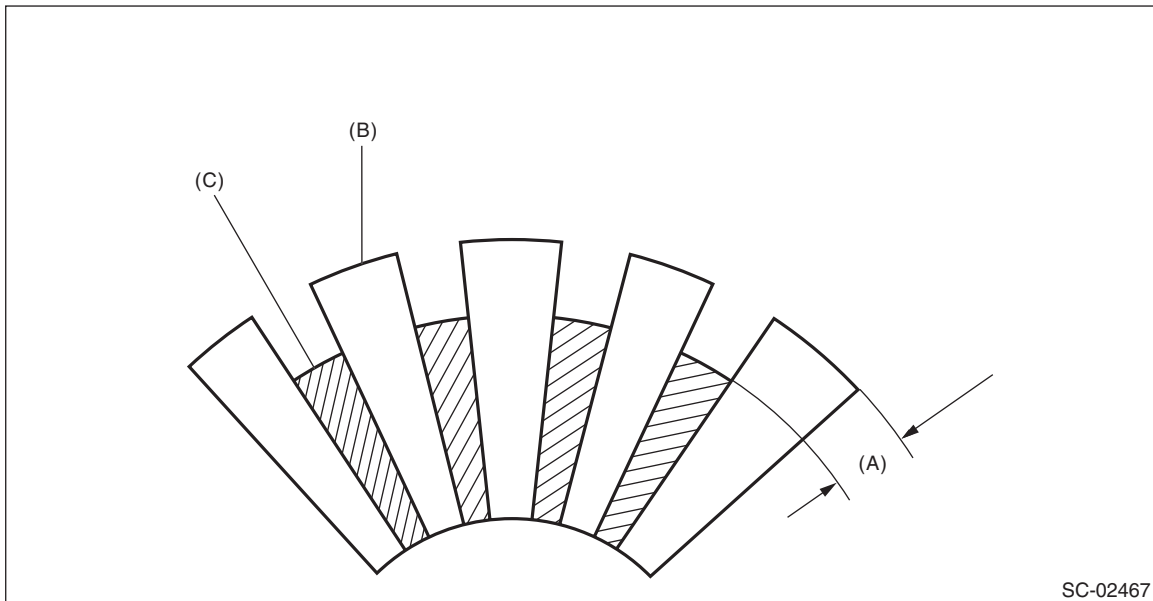

(A) Depth of mold

(B) Segment

(C) Mold

4) Place the armature on the growler tester to check for short circuits. While slowly turning the armature, support the steel sheet for the armature core. If the circuit of the armature is shorted, the steel sheet will vibrate, causing it to move towards the core. When the steel sheet has moved or vibrated, replace the armature.

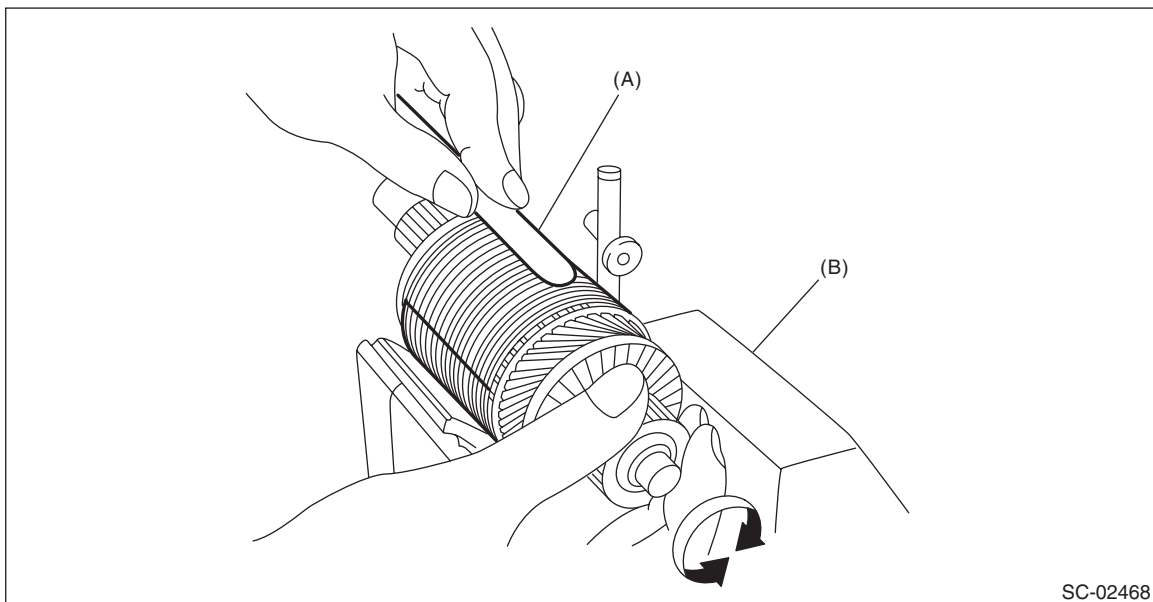

(A) Steel sheet

(B) Growler tester

5) Use a circuit tester to touch the probe of one side to the commutator segment, and the other probe to the shaft. If there is continuity, replace the armature.

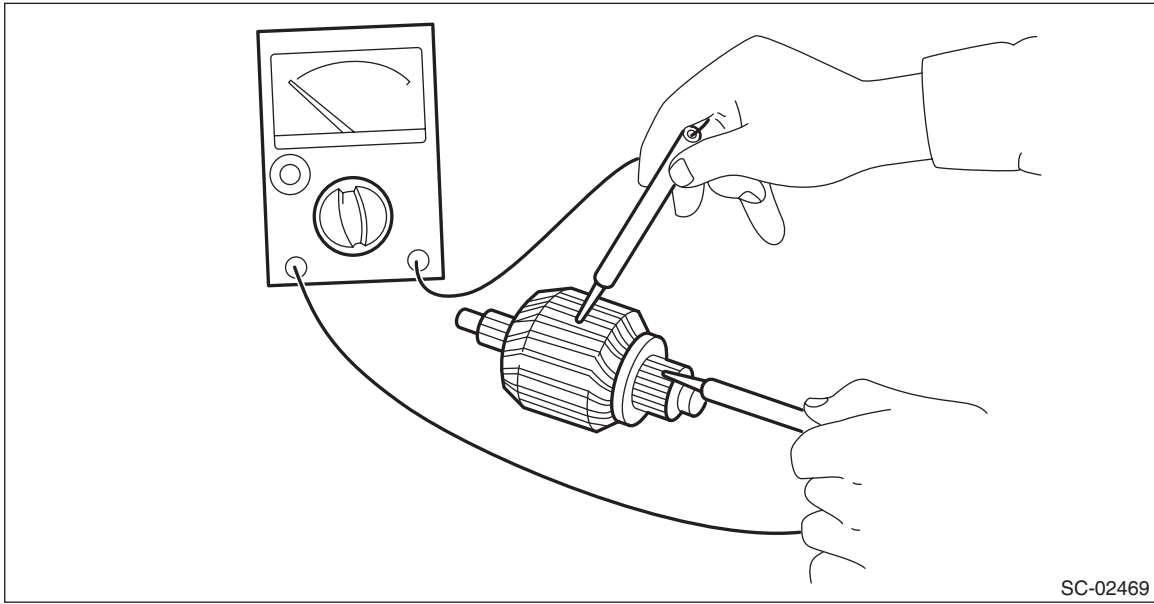

2. YOKE

Make sure that the pole is set at the predetermined position.

3. OVERRUNNING CLUTCH

Inspect the pinion, and if there is any wear or damage, replace the overrunning clutch. Also, check that the pinion rotates counterclockwise smoothly and does not rotate clockwise. If there is any fault, replace the overrunning clutch.

CAUTION:

To prevent spilling of grease, do not clean the overrunning clutch with oil.

Starter

STARTING/CHARGING SYSTEMS

4. BRUSH AND BRUSH HOLDER

- 1) Visually check the brush. If there is any abnormal wear or cracks, replace the brush.
- 2) Measure the length of the brush. If it exceeds service limits, replace the brush.

Brush length:

Standard

12.3 mm (0.484 in)

Limit

7.0 mm (0.276 in)

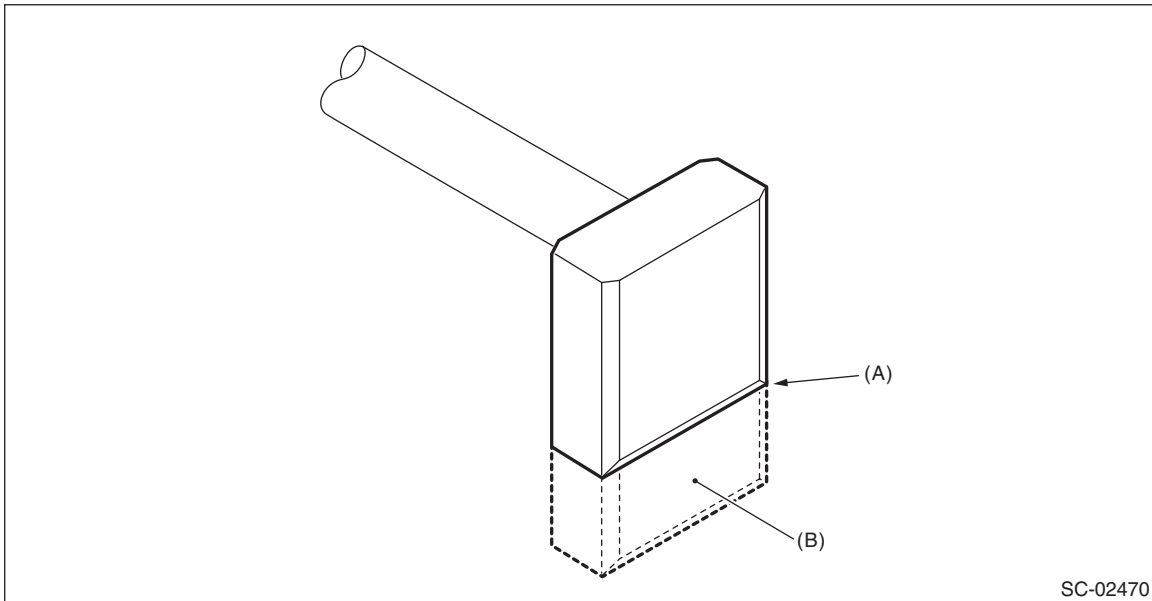

(A) Service limit line

(B) Brush

- 3) Check that the brush moves smoothly in the brush holder.
- 4) Measure the brush spring force with a spring scale. Replace the brush holder if below the service limit.

Brush spring force:

Standard

15.9 — 19.5 N (1.62 — 1.99 kgf, 3.57 — 4.38 lbf) (When new)

Limit

2.5 N (0.25 kgf, 0.56 lbf)

5. SWITCH ASSEMBLY

Using a circuit tester (set to “ohm”), check that there is continuity between terminals S and M, and between terminal S and ground. Also check to be sure there is no continuity between terminal M and B.

Resistance between switch assembly terminals:

Terminals	Standard
S — M	1 Ω or less
S — Ground	1 Ω or less
M — B	1 M Ω or more

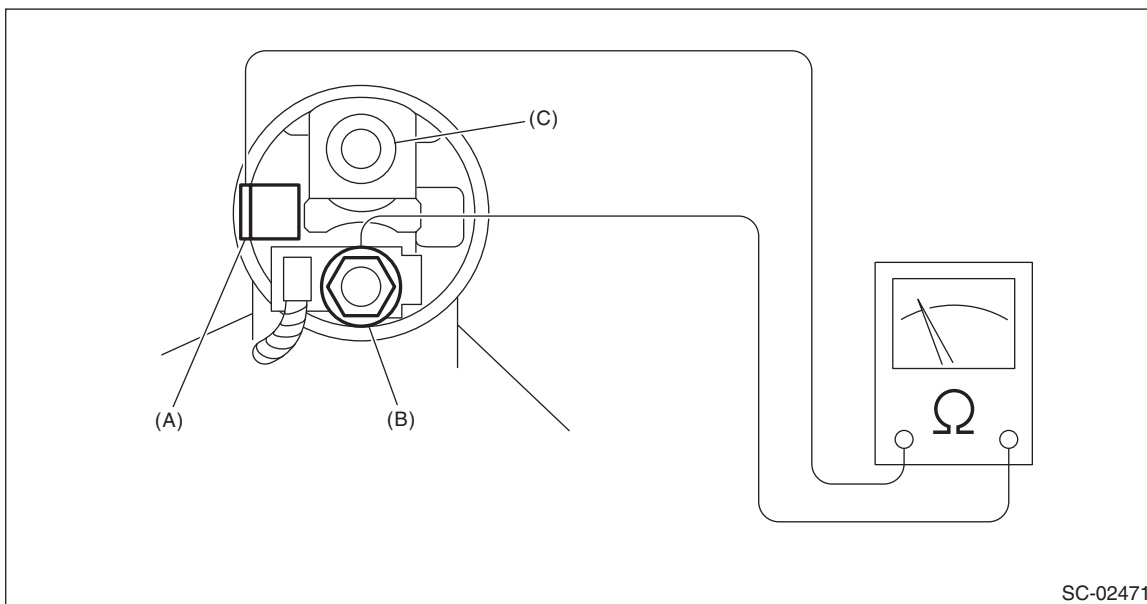

SC-02471

(A) Terminal S

(B) Terminal M

(C) Terminal B

Starter

STARTING/CHARGING SYSTEMS

6. SWITCH ASSEMBLY OPERATION

1) Using a lead wire, connect the switch assembly terminal S to the positive terminal of battery, and the starter body to the ground terminal of battery. The pinion should be forced endwise on shaft.

NOTE:

With the pinion forced endwise on shaft, starter motor can sometimes rotate because current flows, through pull-in coil, to motor. This is not a problem.

2) Disconnect the connector from terminal M. Then using a lead wire, connect the positive terminal of battery and terminal M, and ground terminal to starter body.

In this test set up, the pinion should return to its original position even when it is pulled out with a screwdriver.

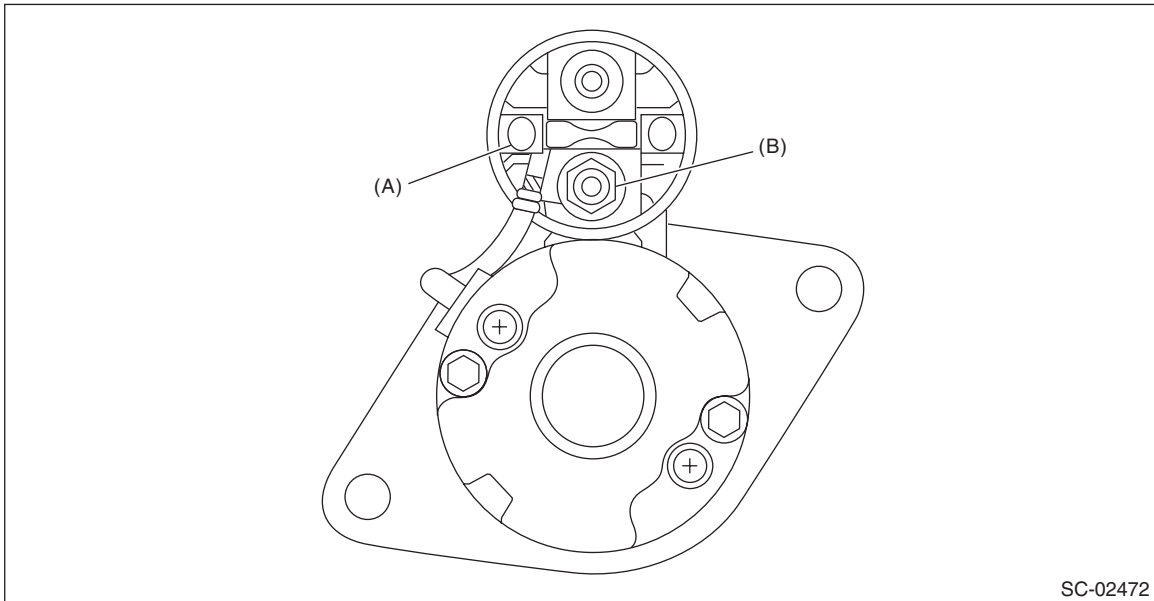

SC-02472

(A) Terminal S

(B) Terminal M

7. PERFORMANCE TEST

The starter should be submitted to performance tests whenever it has been overhauled, to assure its satisfactory performance when installed on the engine.

Three performance tests, no-load test, load test, and lock test, are presented here; however, if the load test and lock test cannot be performed, carry out at least the no-load test.

For these performance tests, use the circuit shown in figure.

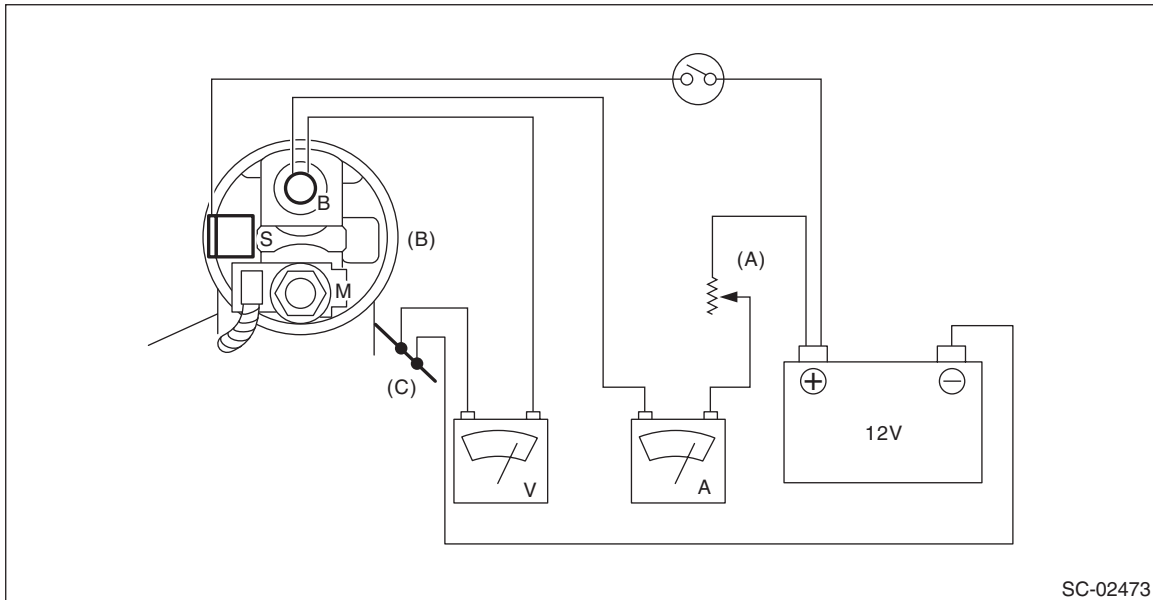

(A) Variable resistance

(B) Magnet switch

(C) Starter body

1) Adjust the variable resistance with the switch on until the voltage is 11 V, and read the value displayed by the ammeter to measure starter speed. Compare these values with the standard.

No-load test (standard):

Voltage/Current

CVT model

Max. 11 V/90 A or less

MT model

Max. 11 V/95 A or less

Rotating speed

CVT model

2,370 rpm or more

MT model

2,500 rpm or more

Starter

STARTING/CHARGING SYSTEMS

2) Apply the specified braking torque to starter. The condition is normal if the current draw and starter speed are within standard.

Load test (standard):

Voltage/Load

CVT model

7.5 V/10.65 N·m (1.1 kgf-m, 7.8 ft-lb)

MT model

7.5 V/8.84 N·m (0.9 kgf-m, 6.5 ft-lb)

Current/Speed

CVT model

300 A/840 rpm or more

MT model

300 A/870 rpm or more

3) With the starter stalled, or not rotating, measure the torque developed and current draw when the voltage is adjusted to standard voltage.

Lock test (standard):

Voltage/Current

CVT model

4 V/780 A or less

MT model

4 V/680 A or less

Torque

CVT model

20 N·m (2.0 kgf-m, 14.8 ft-lb) or more

MT model

17 N·m (1.7 kgf-m, 12.5 ft-lb) or more

8. OTHER INSPECTIONS

Check that the starter does not have deformation, cracks and any other damage.