

3. Generator

A: REMOVAL

1) Remove the V-belt covers.

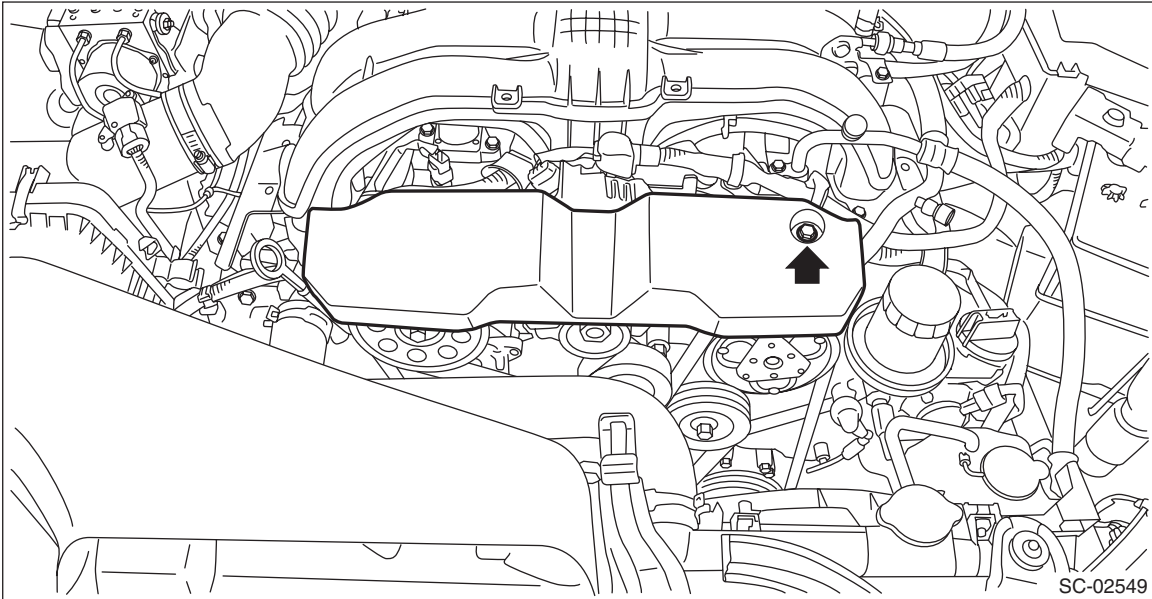

2) Disconnect the ground cable from battery.

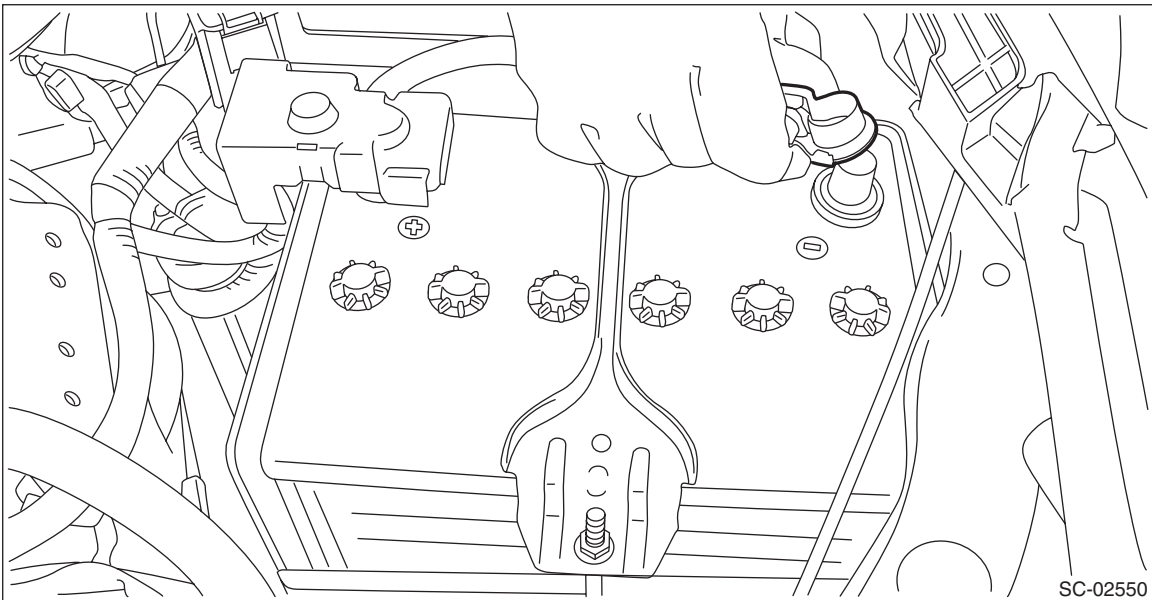

3) Remove the V-belts. <Ref. to ME(H4DO)-75, REMOVAL, V-belt.>

Generator

STARTING/CHARGING SYSTEMS

4) Remove the V-belt cover bracket.

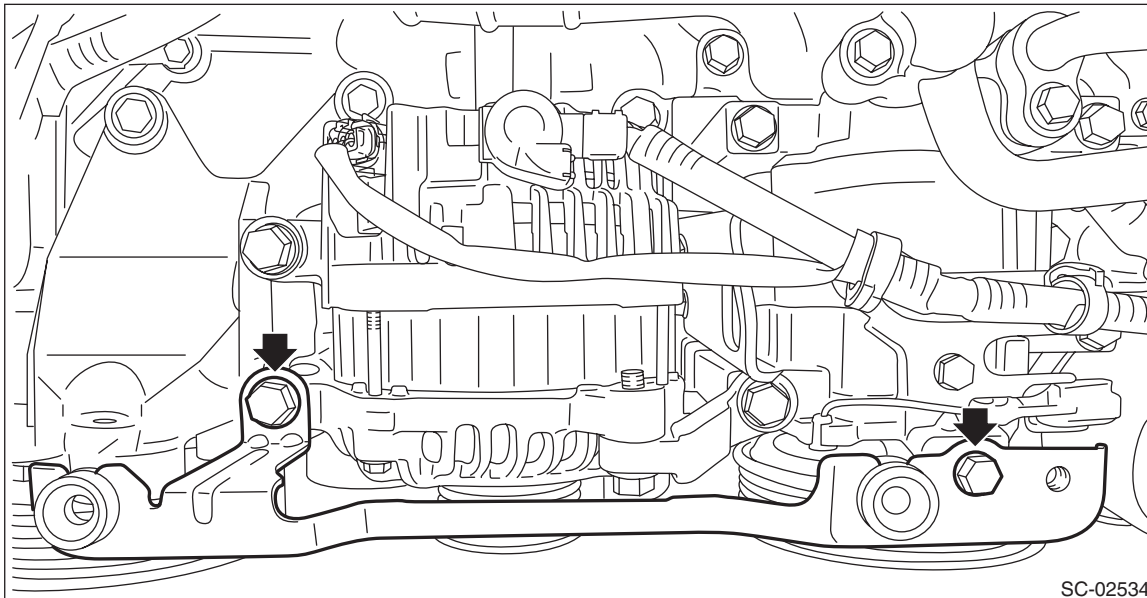

5) Disconnect the connector (A) and terminal (B) from the generator.

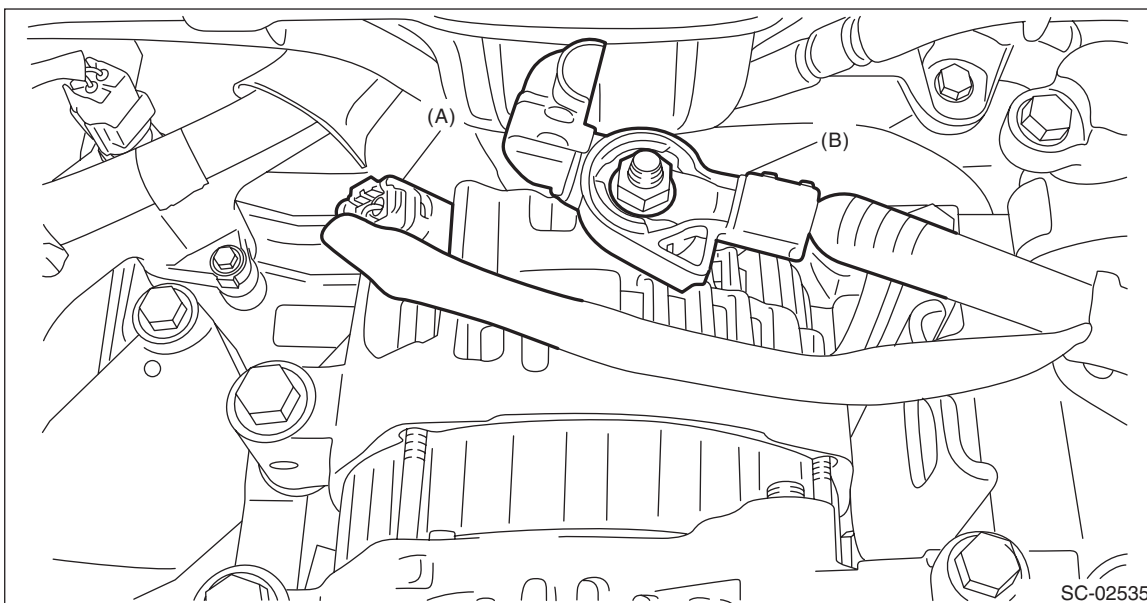

6) Remove the idler pulley from the chain cover.

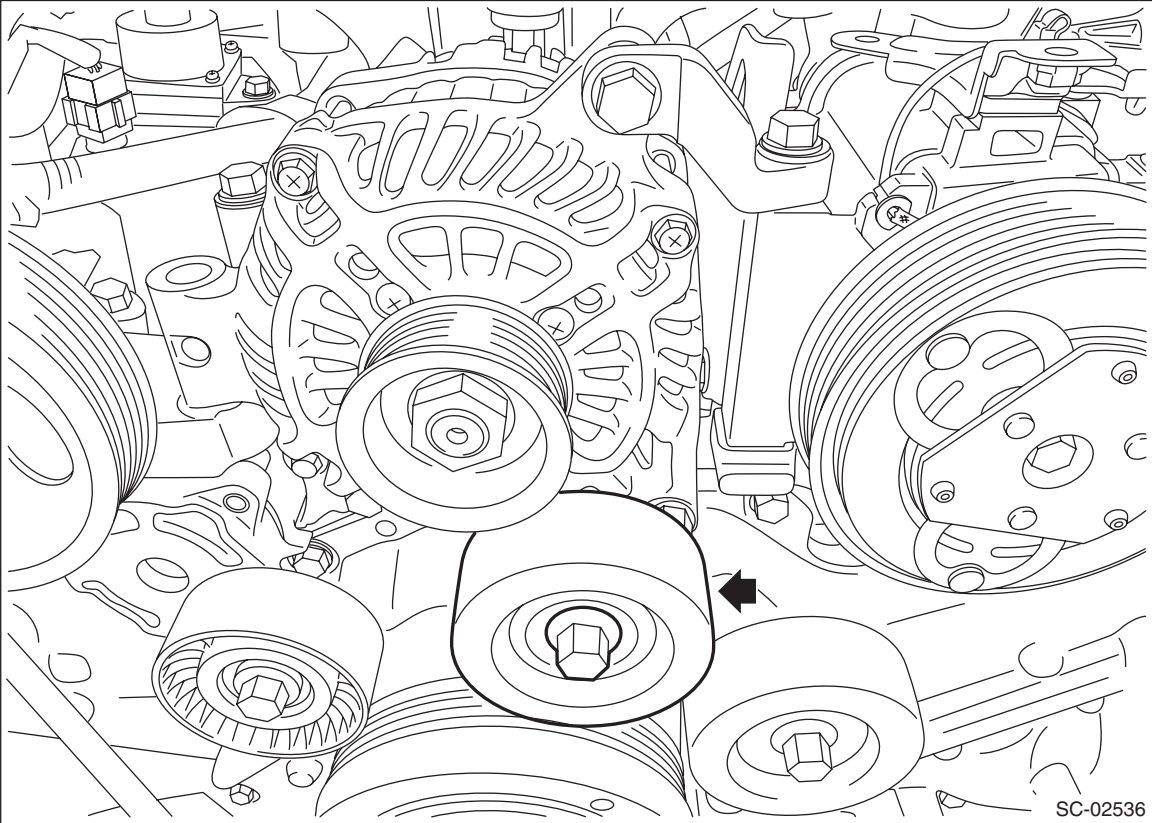

7) Remove the generator from the bracket.

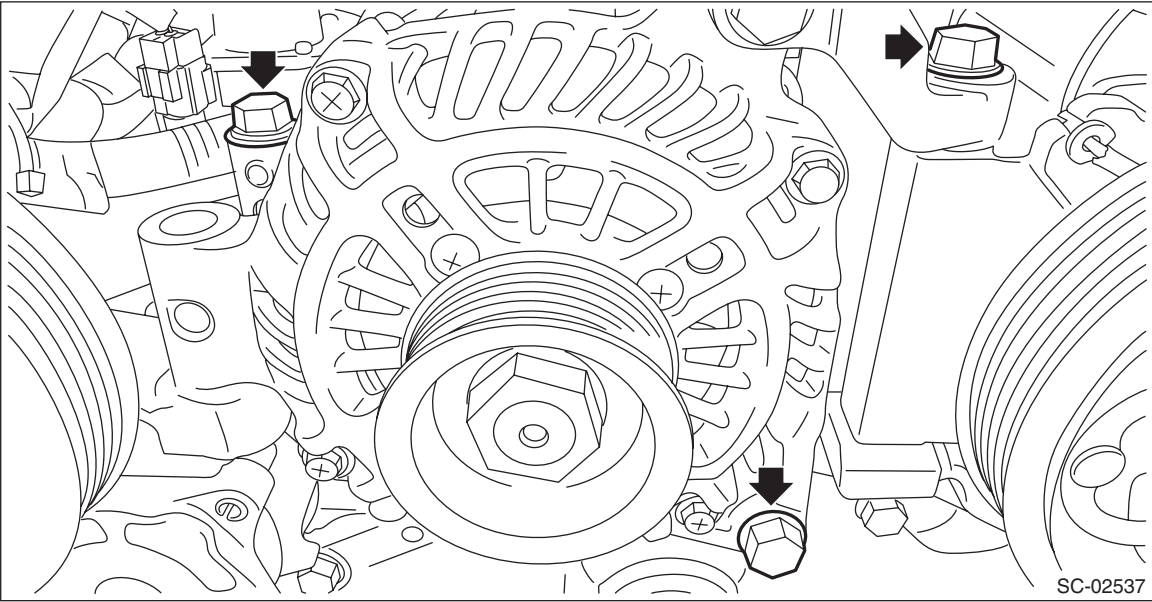

Generator

STARTING/CHARGING SYSTEMS

8) Remove the generator bracket from the generator.

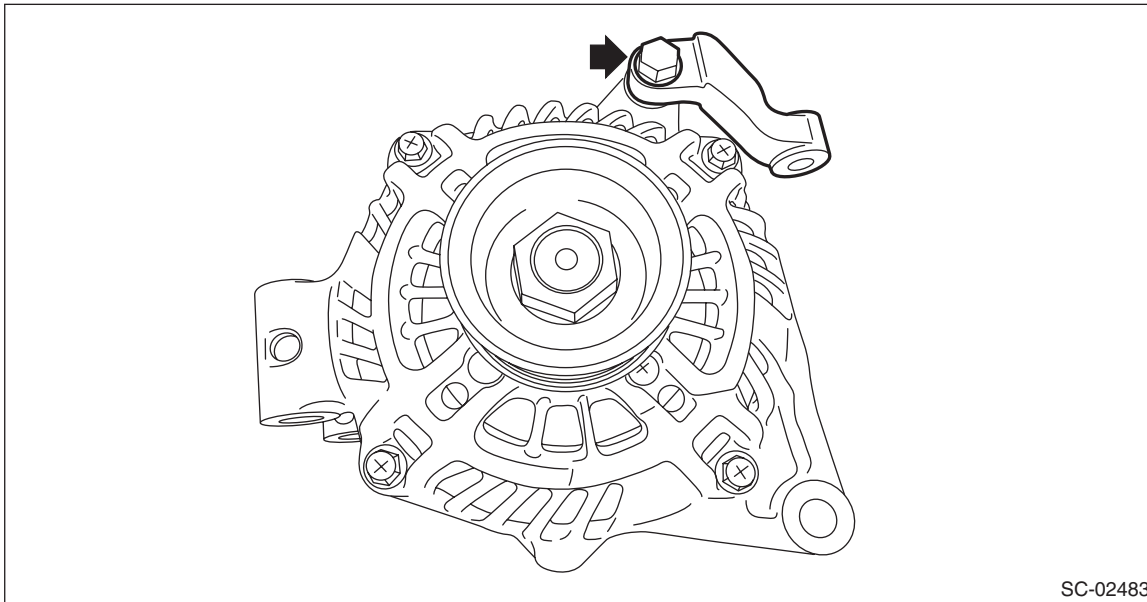

B: INSTALLATION

1) Temporarily install the generator bracket to the generator.

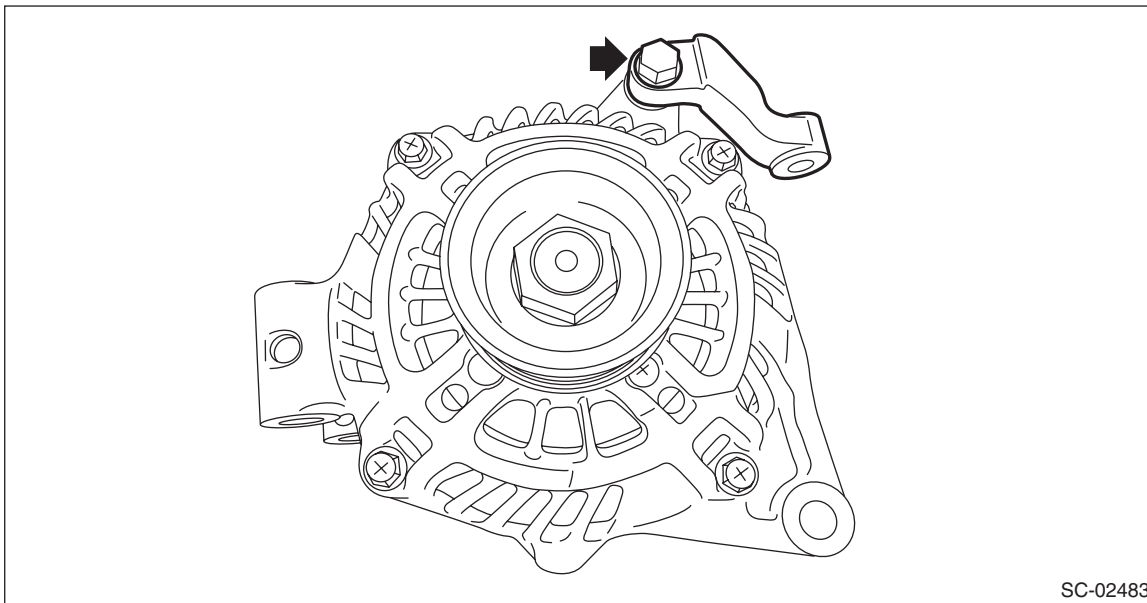

2) Temporarily install the generator to the engine.

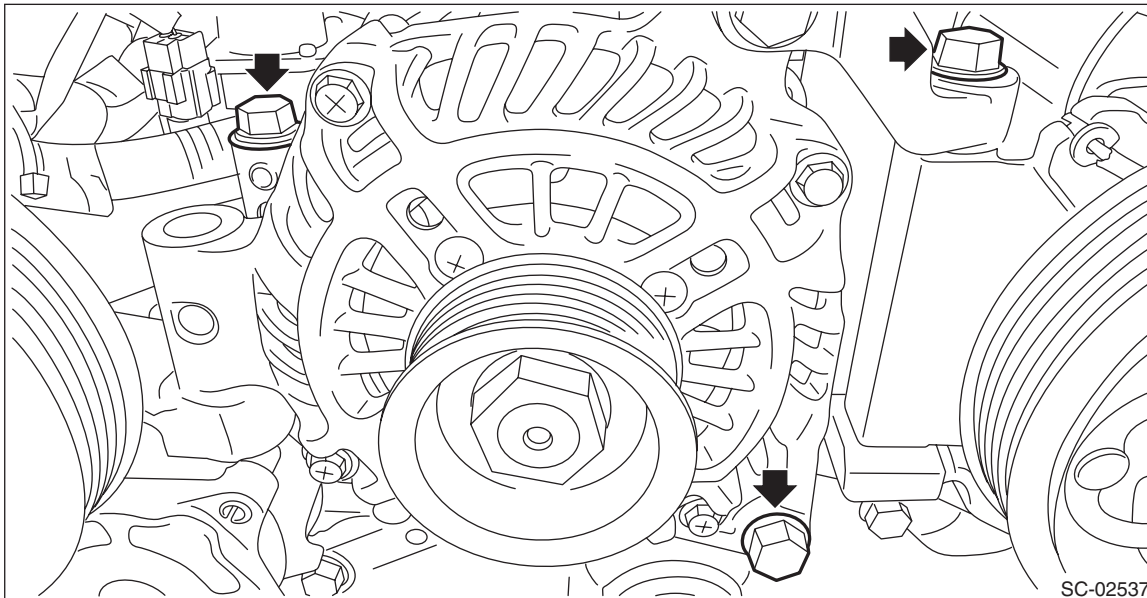

3) Tighten the generator and generator bracket in the numerical order.

Tightening torque:

T1: 25 N·m (2.5 kgf-m, 18.4 ft-lb)

T2: 36 N·m (3.7 kgf-m, 26.6 ft-lb)

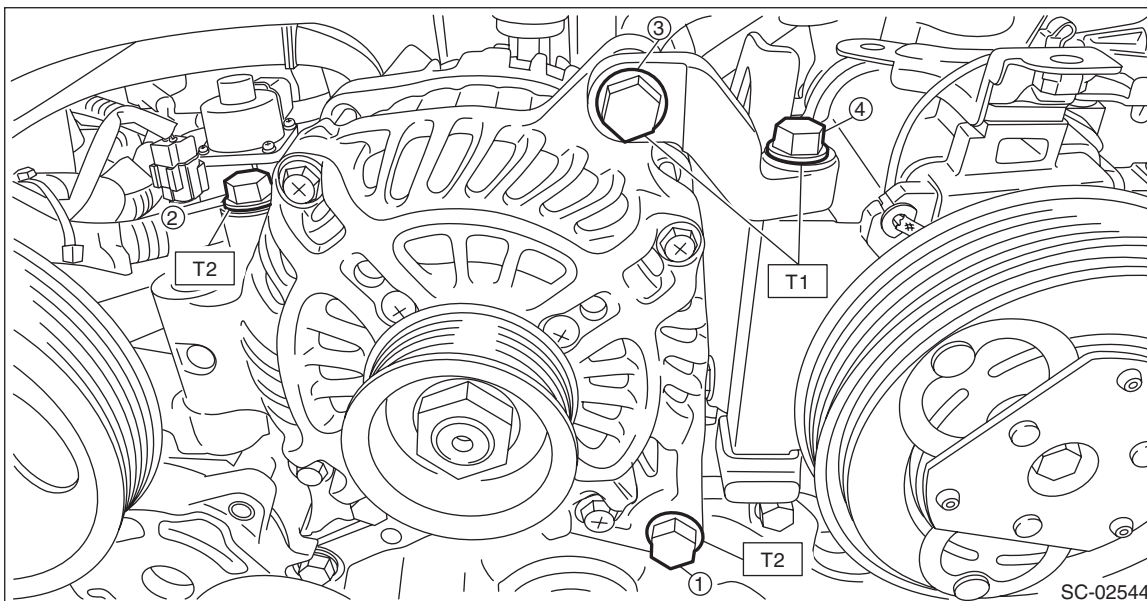

Generator

STARTING/CHARGING SYSTEMS

4) Install the V-belt cover bracket and tighten the bolts in the numerical order.

Tightening torque:

T1: 8.5 N·m (0.9 kgf-m, 6.3 ft-lb)

T2: 36 N·m (3.7 kgf-m, 26.6 ft-lb)

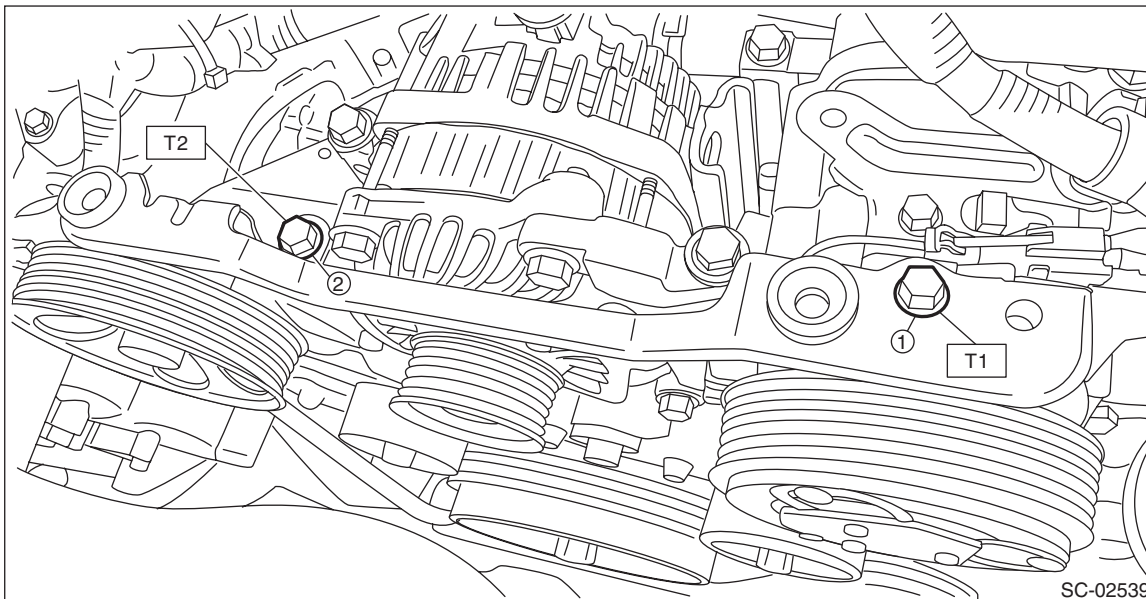

5) Install the idler pulley to the chain cover.

Tightening torque:

36 N·m (3.7 kgf-m, 26.6 ft-lb)

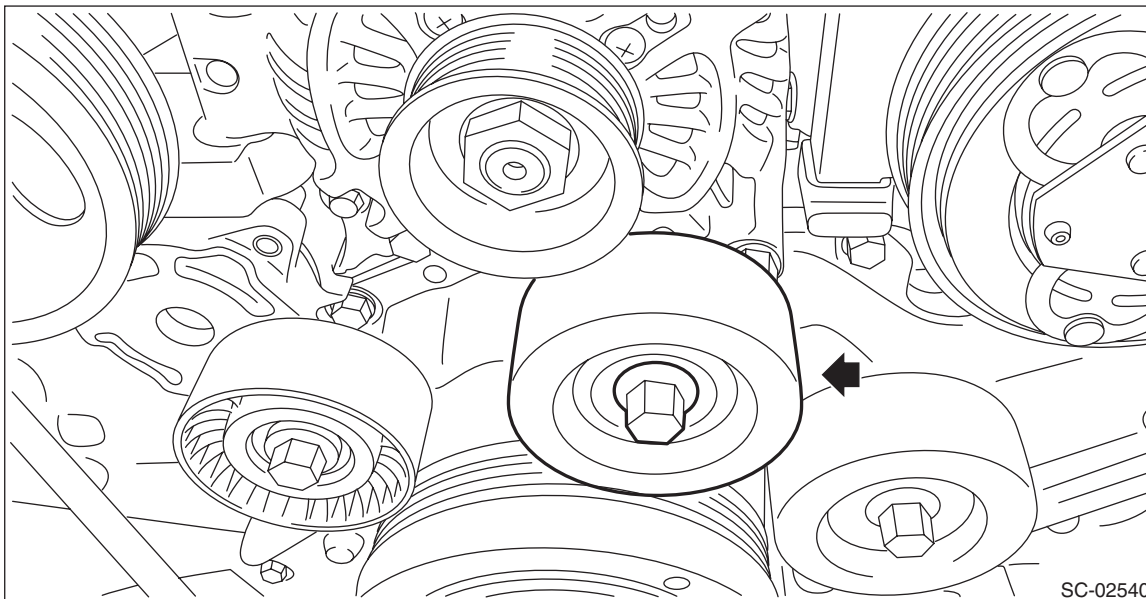

6) Connect the connector (A) and terminal (B) to the generator.

Tightening torque:

16 N·m (1.6 kgf-m, 11.8 ft-lb)

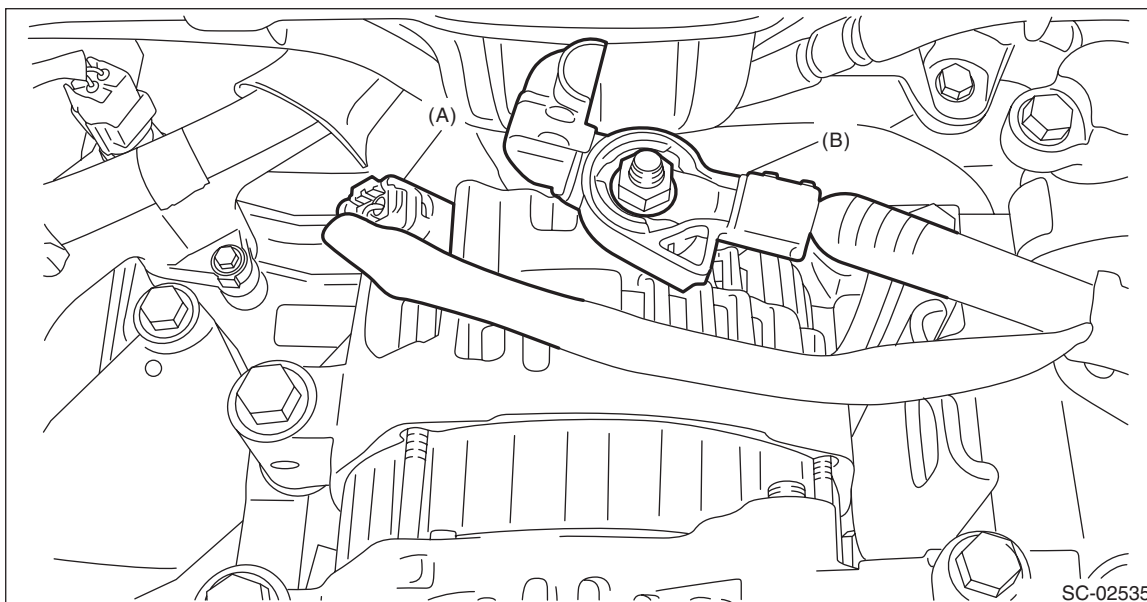

7) Install the V-belts. <Ref. to ME(H4DO)-77, INSTALLATION, V-belt.>

8) Connect the battery ground terminal.

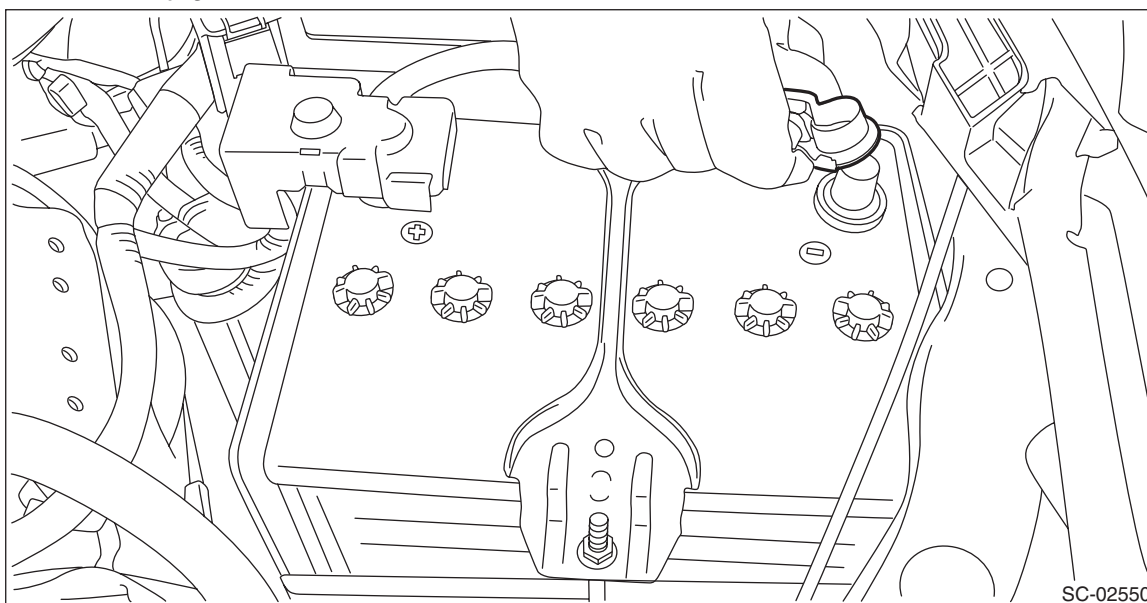

Generator

STARTING/CHARGING SYSTEMS

9) Install the V-belt cover.

Tightening torque:

13 N·m (1.3 kgf·m, 9.6 ft·lb)

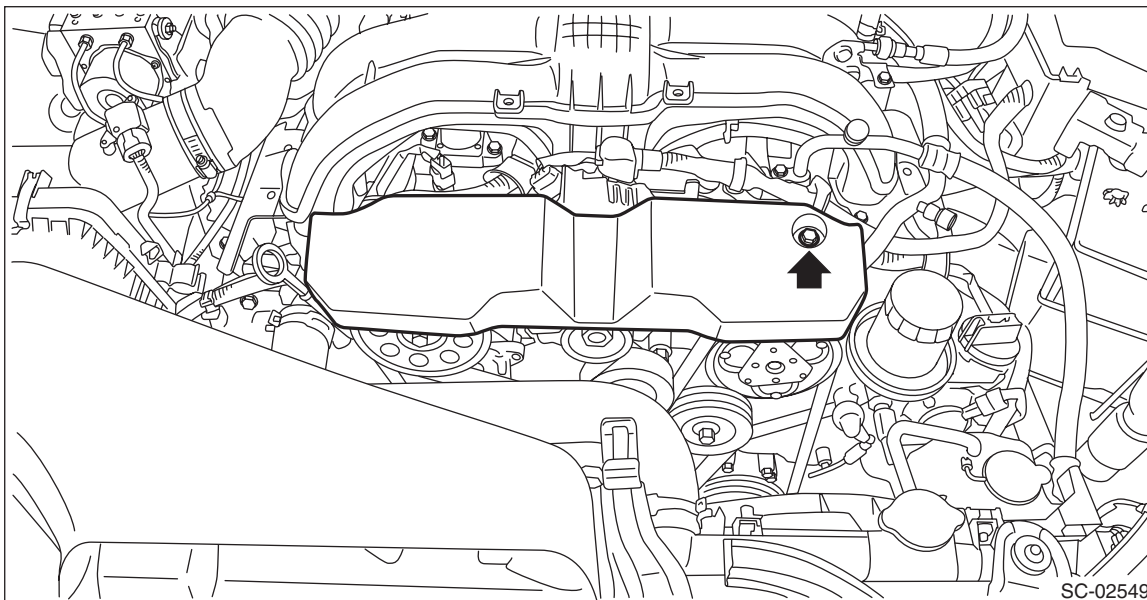

C: DISASSEMBLY

1) Remove the four through bolts.

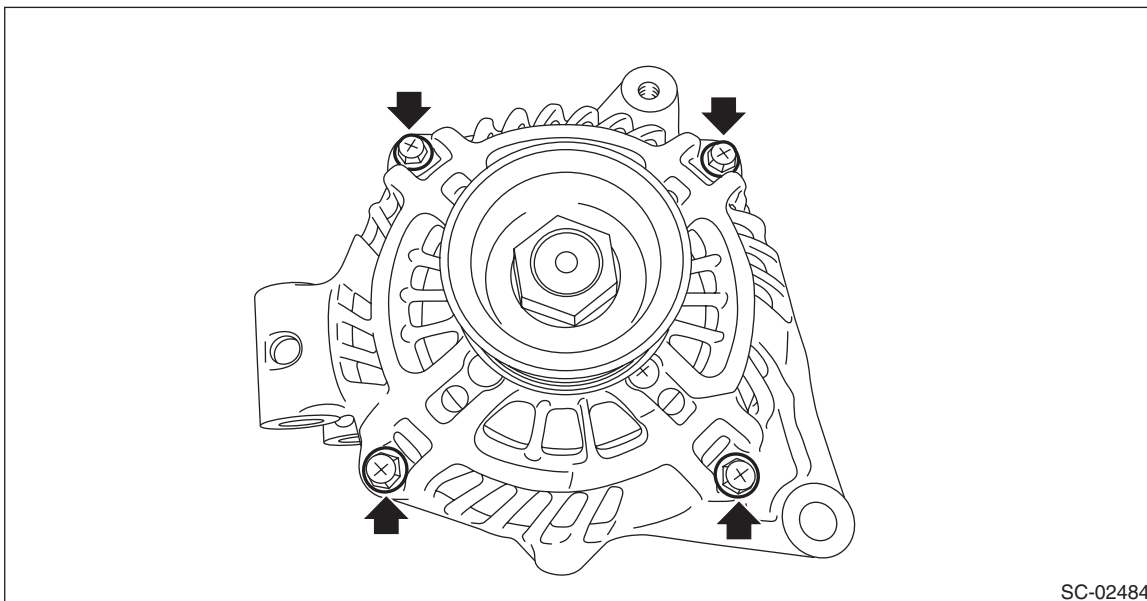

Generator

STARTING/CHARGING SYSTEMS

- 2) Use a drier to heat the rear cover (A) portion to 50 — 60°C (122 — 140°F).

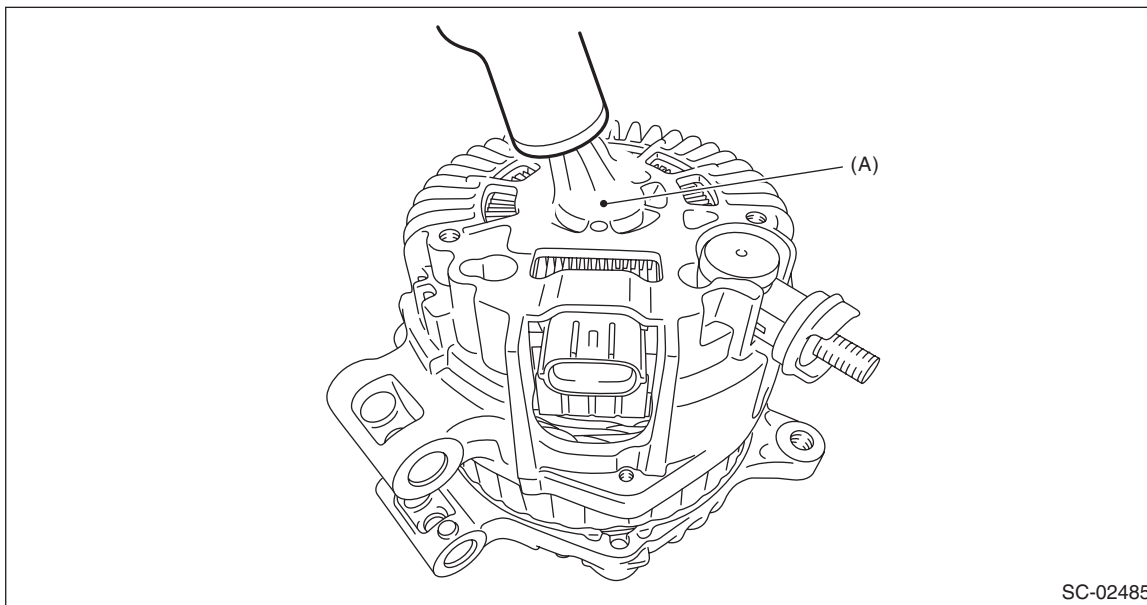

- 3) Insert the flat tip screwdriver into the gap between stator core and front cover to disassemble.

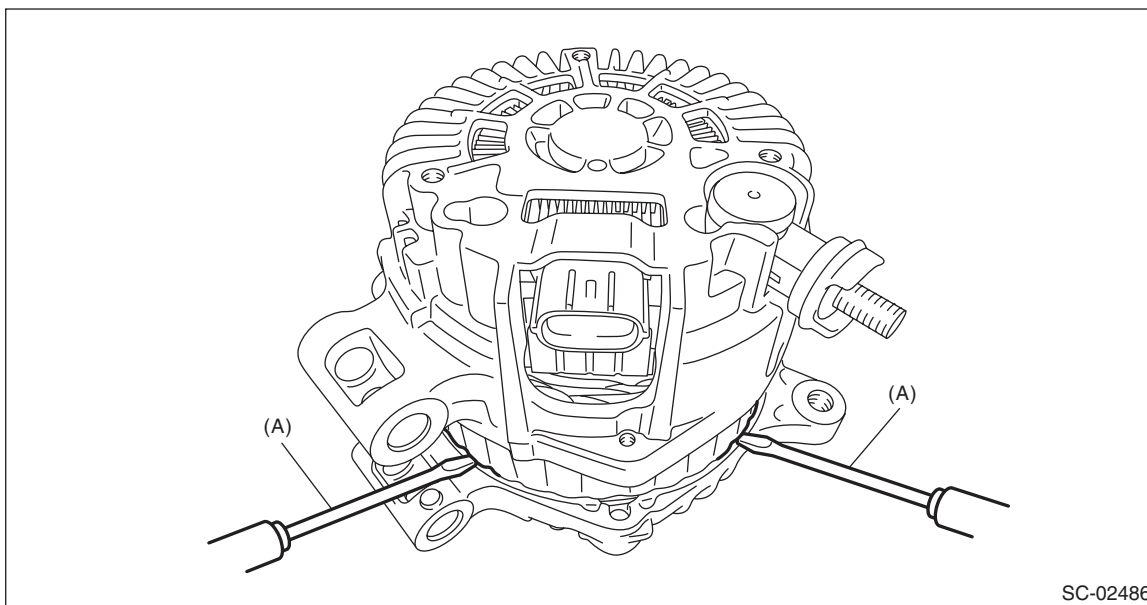

- (A) Flat tip screwdriver

Generator

STARTING/CHARGING SYSTEMS

4) Using a vise, support the rotor and remove the pulley nut, then remove the rotor from the front cover.

CAUTION:

When holding the rotor with a vise, place aluminum plates or wooden pieces on the vise jaws to prevent rotor from damage.

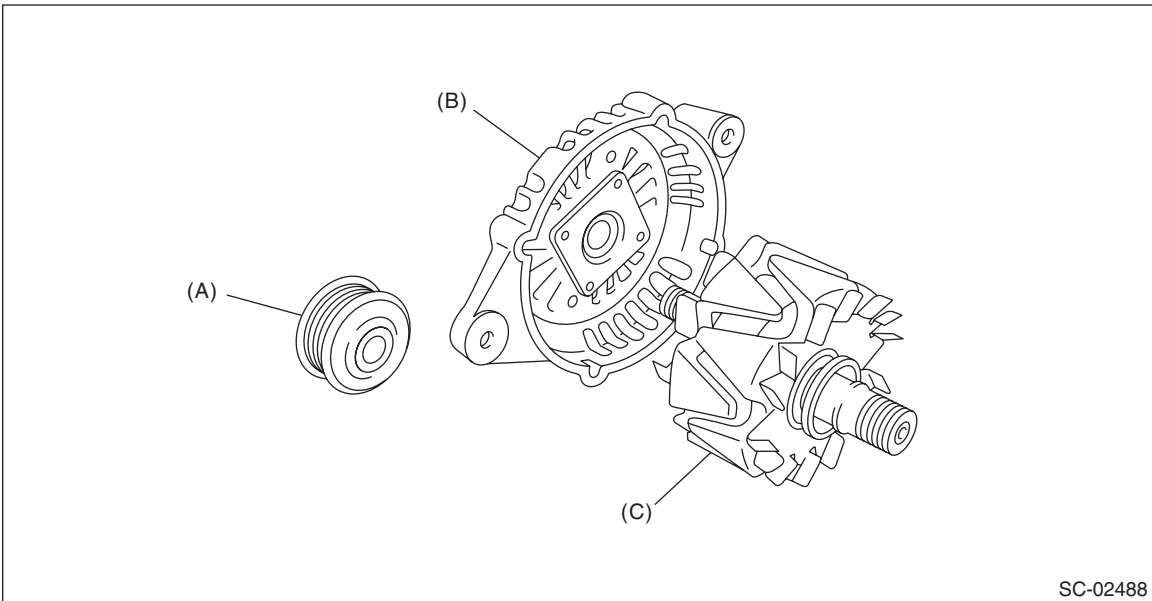
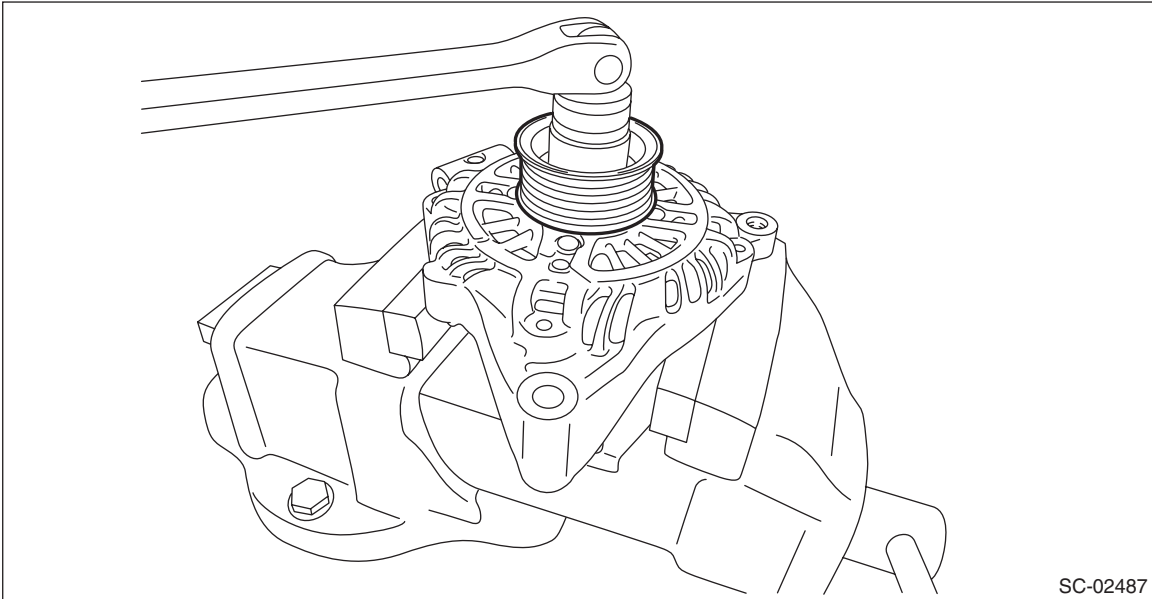

(A) Pulley

(B) Front cover

(C) Rotor

- 5) Use the following procedures to remove the ball bearings.
- (1) Remove the bolt, and then detach the bearing retainer.

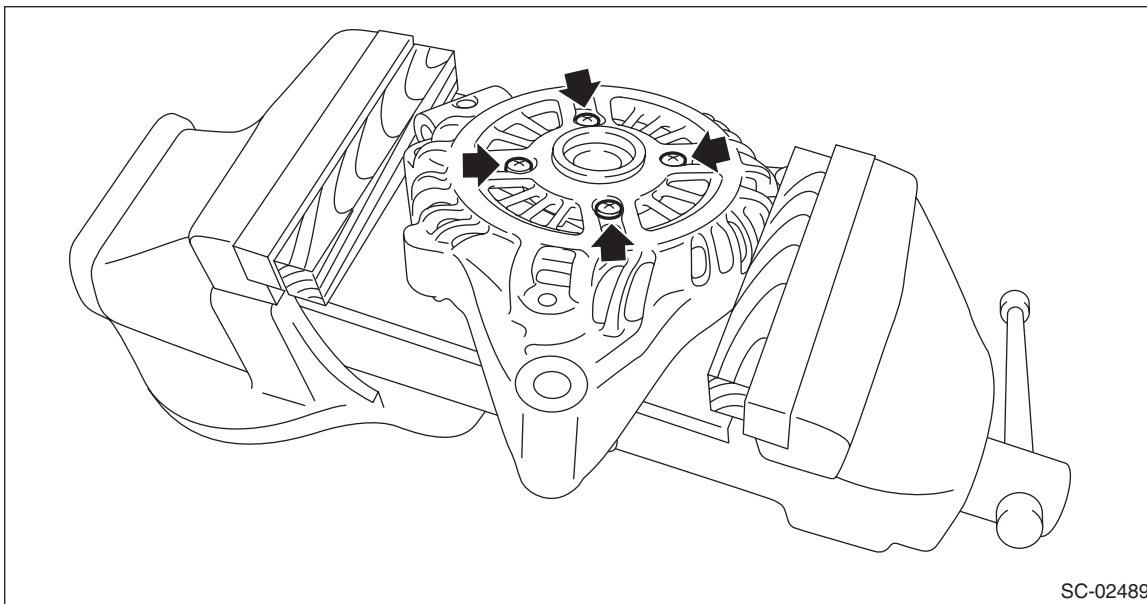

- (2) Firmly attach an appropriate tool (such as a correct size socket wrench) to the bearing inner race.

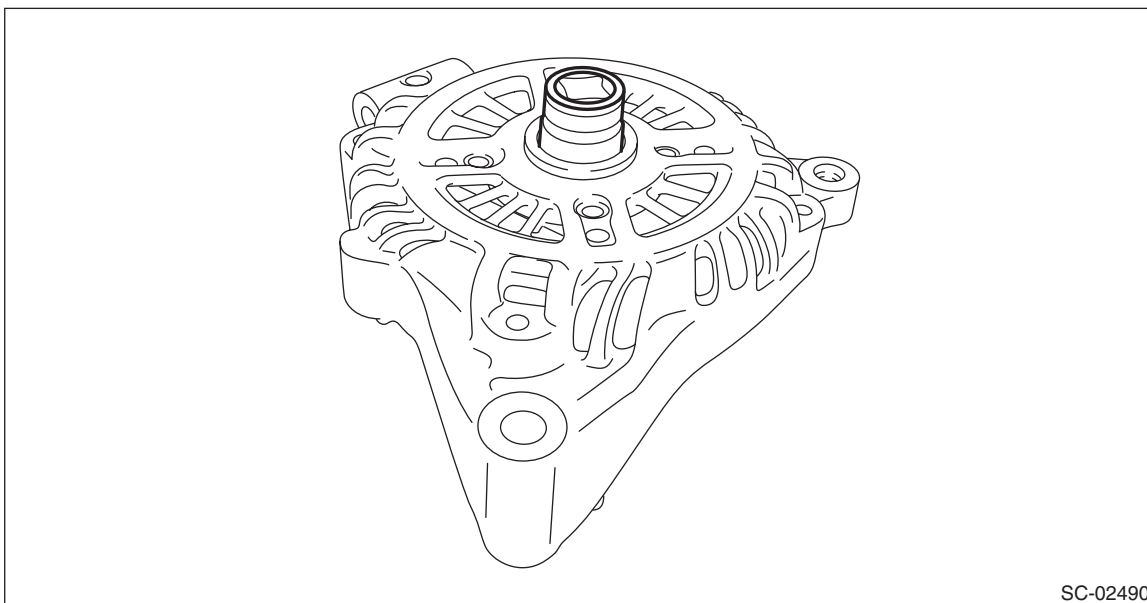

- (3) Use the press to push the ball bearings out from the front cover.

Generator

STARTING/CHARGING SYSTEMS

6) Using the bearing puller, remove the bearings from the rotor.

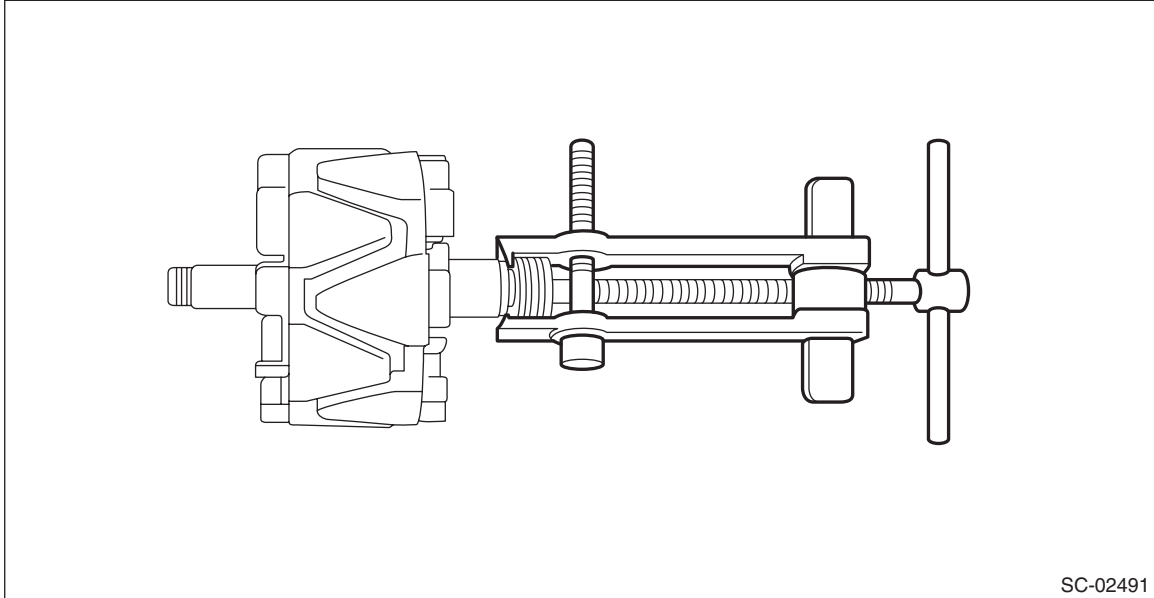

7) Remove six bolts which connect the rectifier and stator coil, then remove the stator coil.

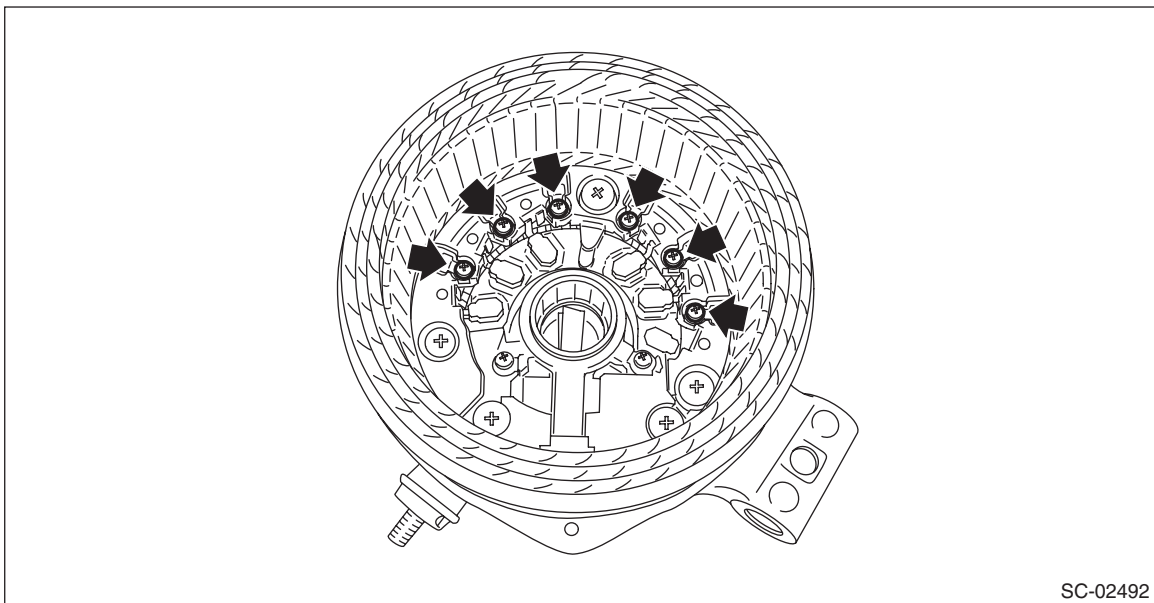

- 8) Remove four screws which secure the IC regulator to the rear cover, then remove the IC regulator.

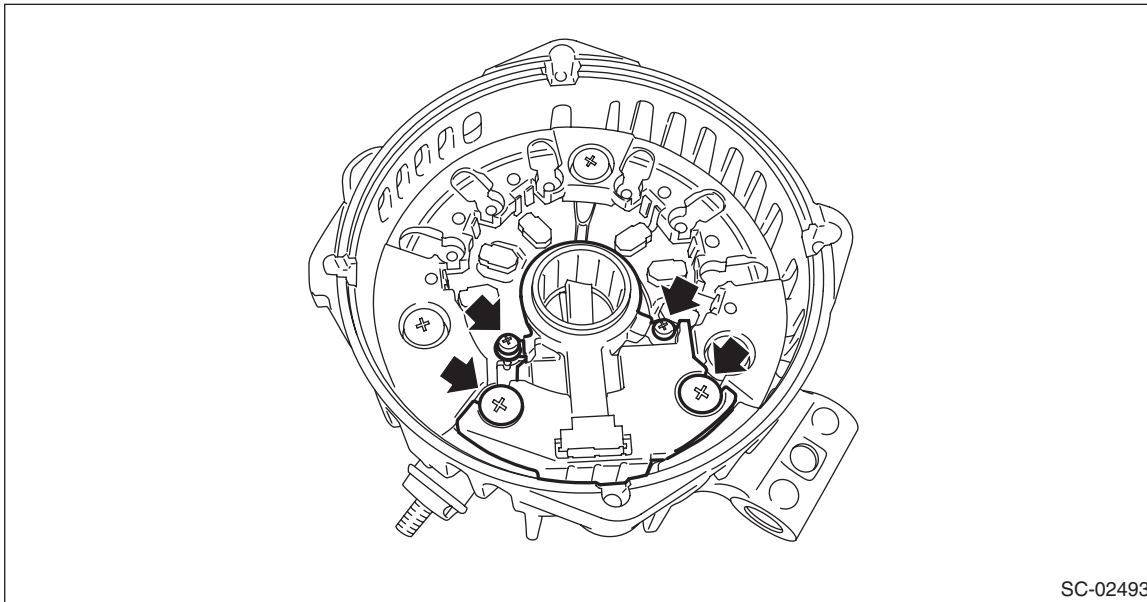

- 9) Use the following procedures to remove the brush.
(1) Remove the cover A.

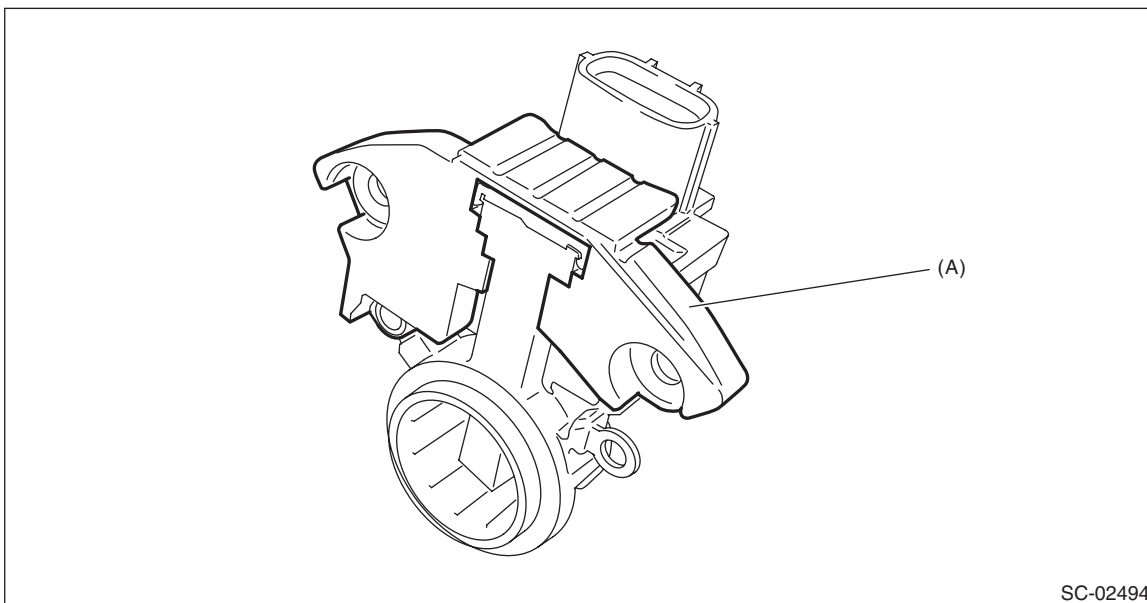

(A) Cover A

Generator

STARTING/CHARGING SYSTEMS

(2) Remove the cover B.

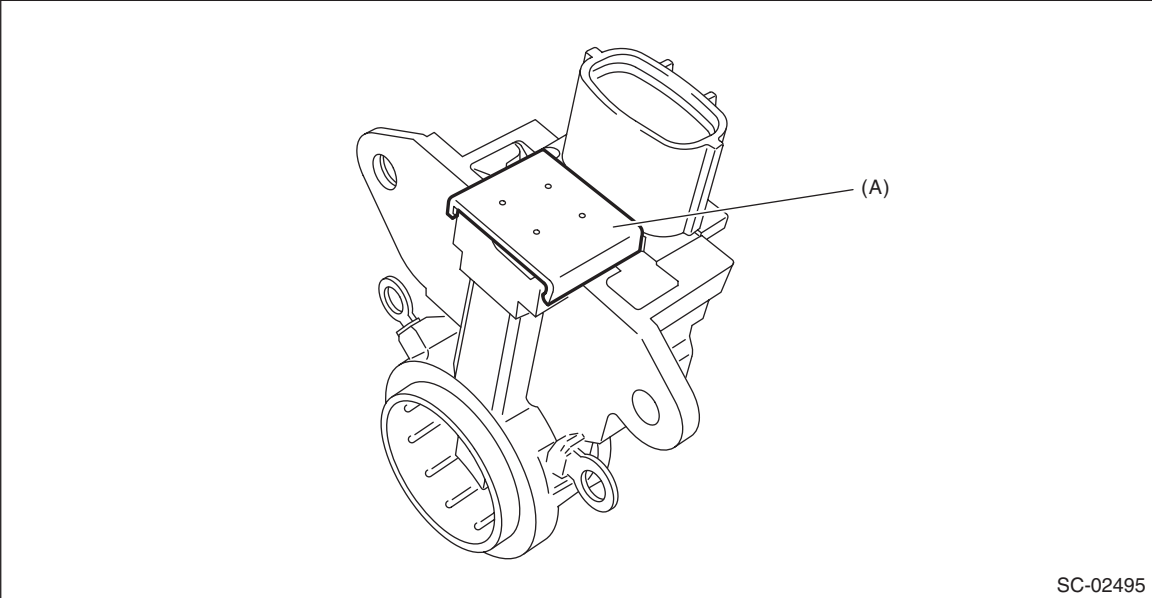

SC-02495

(A) Cover B

(3) Disconnect the connection and remove the brush.

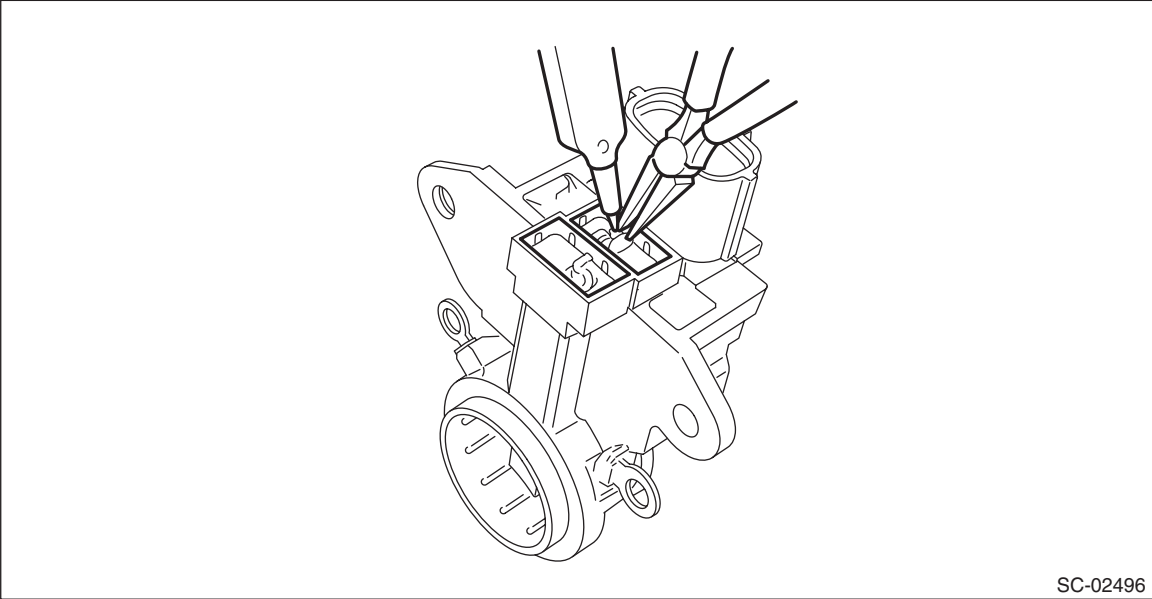

SC-02496

- 10) Remove the rectifier as follows.
(1) Remove the cover on terminal B.

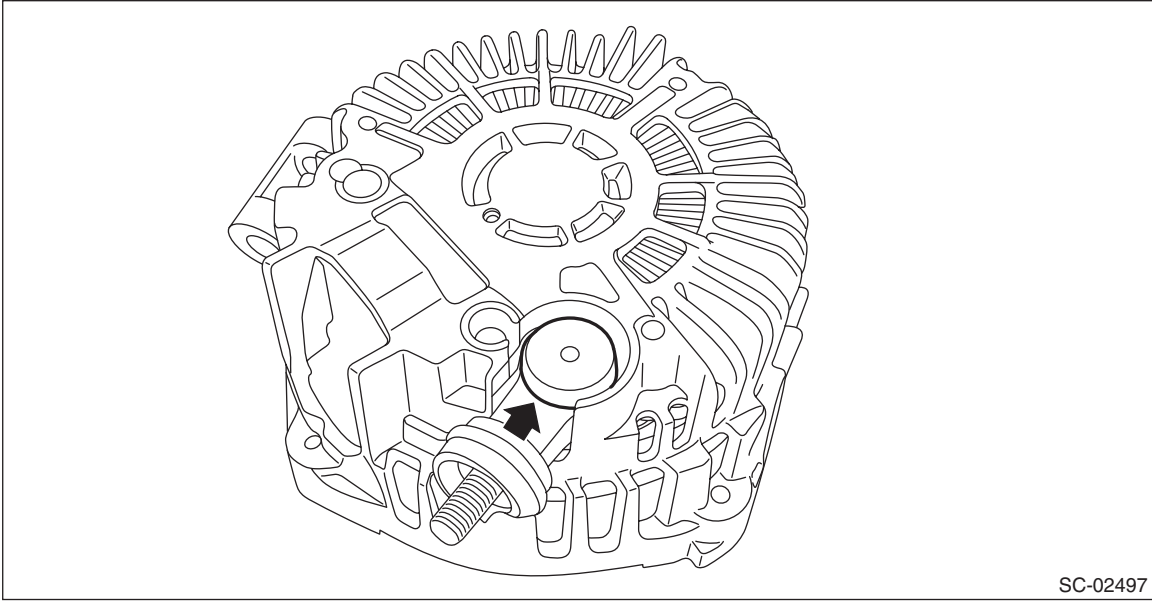

- (2) Remove the nut on terminal B.

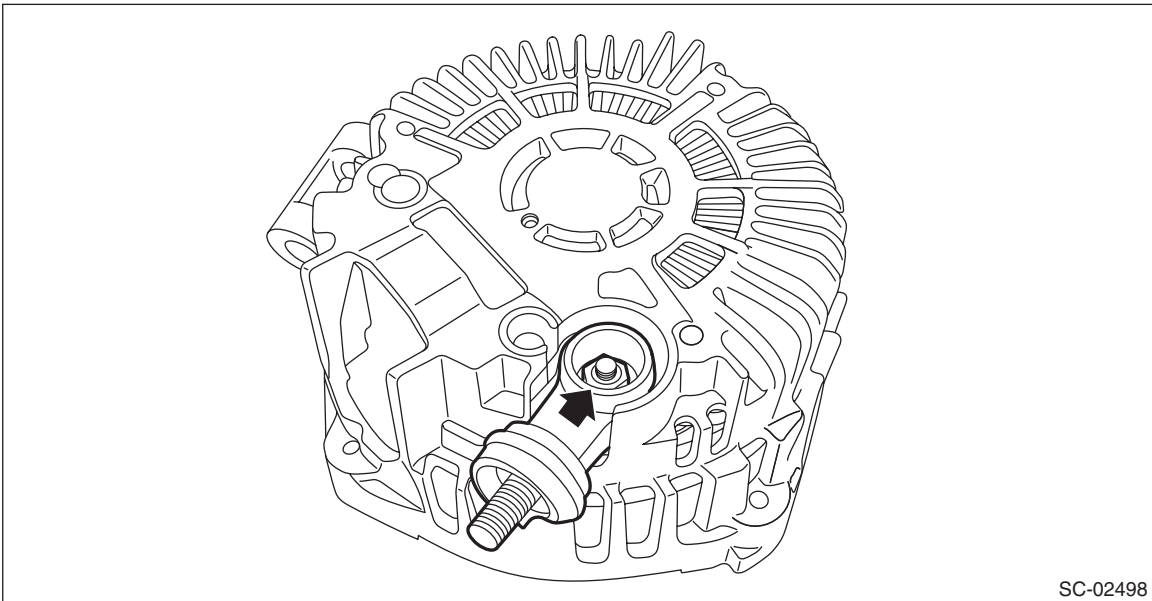

Generator

STARTING/CHARGING SYSTEMS

(3) Remove the bolts which secure the rectifier, and remove the rectifier.

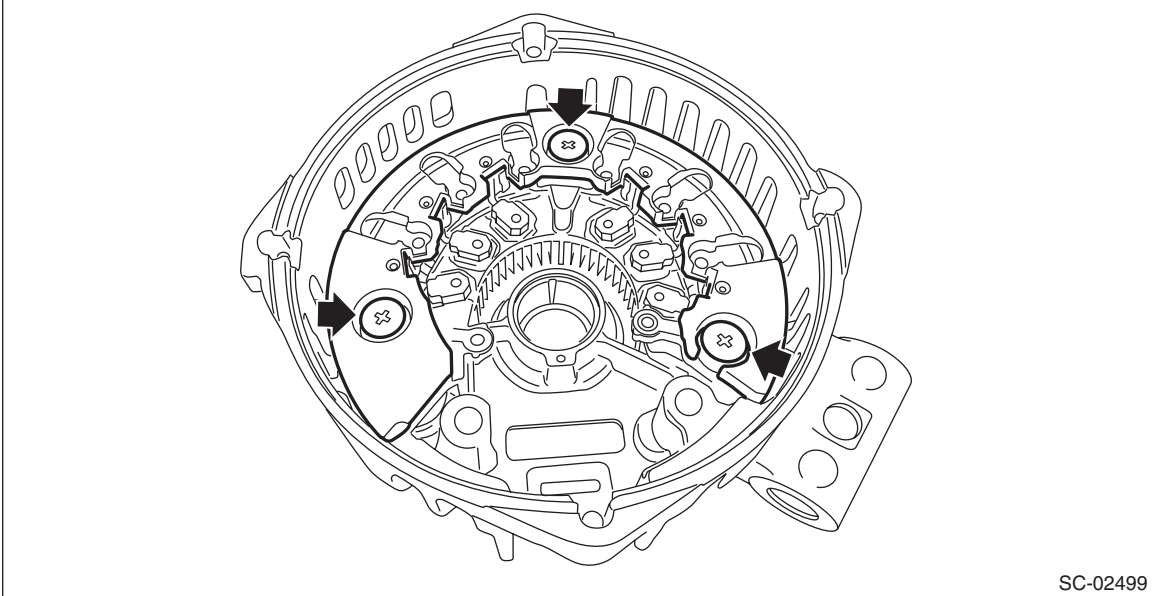

SC-02499

D: ASSEMBLY

Assemble in the reverse order of disassembly.

NOTE:

- Refer to component for tightening torque of each part. <Ref. to SC(H4DO)-4, GENERATOR, COMPONENT, General Description.>

- After assembling, manually turn the pulley to check that the rotor rotates smoothly.

1) Assembling the rear cover and rectifier

Remove old silicone grease on the mating surface of rear cover and rectifier and apply new silicone grease.

CAUTION:

Do not apply silicone grease to the attachment threads of rectifier.

2) Push of the brush

Before assembling the front and rear parts, press the brush down into the brush holder, then fix the brush in that position by inserting a [1 mm (0.0394 in) dia., 40 — 50 mm (1.5748 — 1.9685 in) long] wire through the hole as shown in the figure.

CAUTION:

After assembling, remove the wire.

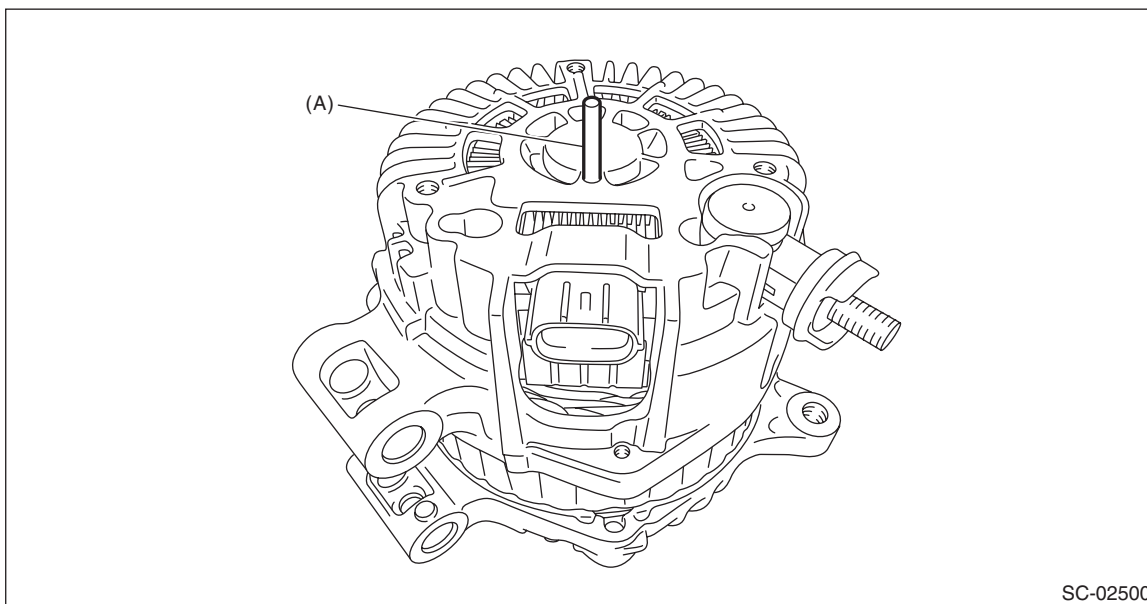

(A) Wire

3) Install the ball bearings.

(1) Set the ball bearings in the front cover, then securely install an appropriate tool (such as a socket wrench of proper size) to the bearing outer race.

(2) Using a press to press the ball bearings into the specified location.

(3) Install the bearing retainer.

4) Install the bearings.

CAUTION:

Do not apply grease to the bearings. If there is any oil on the bearing box, remove it completely.

(1) Use a press to install the bearings to the rotor shaft.

(2) Heat the bearing box in rear cover at 50 to 60°C (122 to 140°F), and then press the bearing into rear cover.

Generator

STARTING/CHARGING SYSTEMS

E: INSPECTION

1. DIODE

CAUTION:

There is the possibility of damaging the diodes if a mega-tester (used to measure high voltages) or a similar measuring instrument is used. Never use a mega tester or equivalent for this test.

1) Check for continuity between the diode lead and terminal E or B. If continuity is not as shown in the table, replace the rectifier.

- At analog type tester

Tester lead		Continuity
-lead	+lead	
E	P1, P2, P3, P4, P5, P6	Yes
B		No
P1, P2, P3, P4, P5, P6	E	No
	B	Yes

- At digital type tester

Tester lead		Continuity
-lead	+lead	
E	P1, P2, P3, P4, P5, P6	No
B		Yes
P1, P2, P3, P4, P5, P6	E	Yes
	B	No

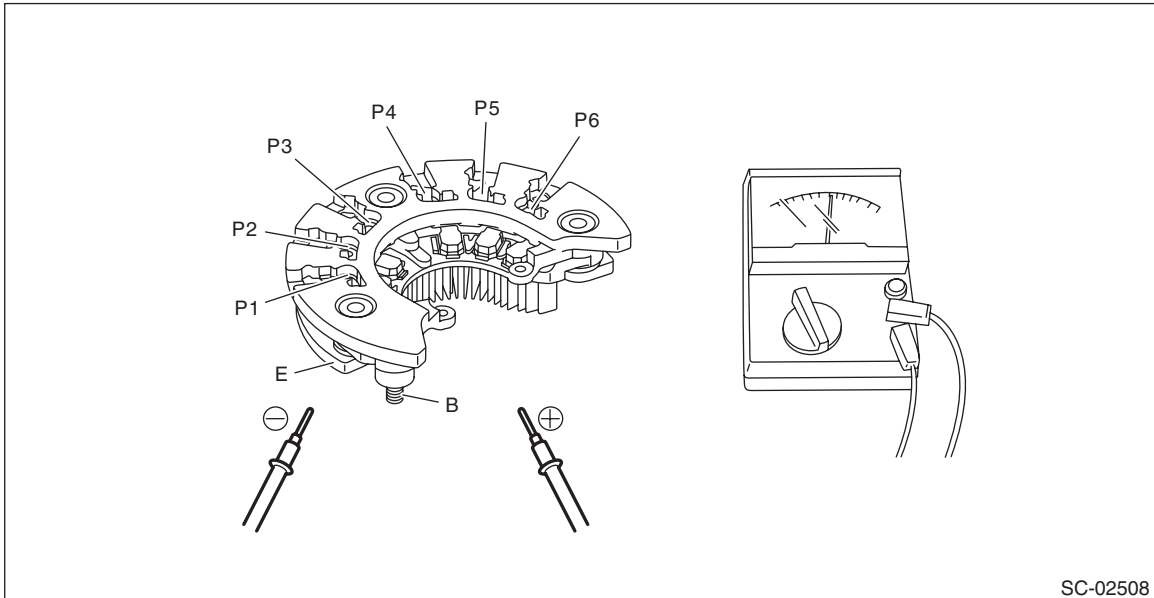

SC-02508

2. ROTOR

1) Slip ring surface

Inspect the slip rings for contamination or any roughness on the sliding surface. Repair the slip ring surface using a lathe or sand paper.

2) Slip ring outer diameter

Measure the slip ring outer diameter. Replace the rotor if the slip ring is worn.

Slip ring outer diameter:

Standard

22.7 mm (0.894 in)

Limit

22.1 mm (0.870 in)

3) Continuity test

Using a circuit tester, check the resistance between slip rings. If the resistance is not within the standard, replace the rotor.

Standard:

Approx. 2.0 — 2.4 Ω

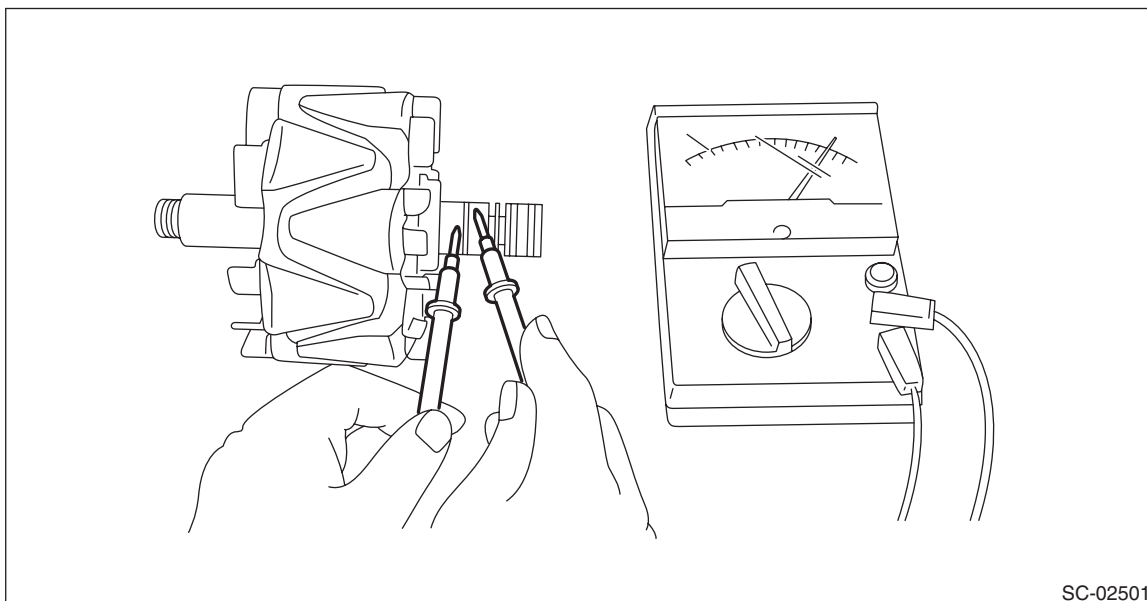

SC-02501

Generator

STARTING/CHARGING SYSTEMS

4) Insulation test

Check the continuity between slip ring and rotor core or shaft. If there is continuity, replace the rotor because the rotor coil is grounded.

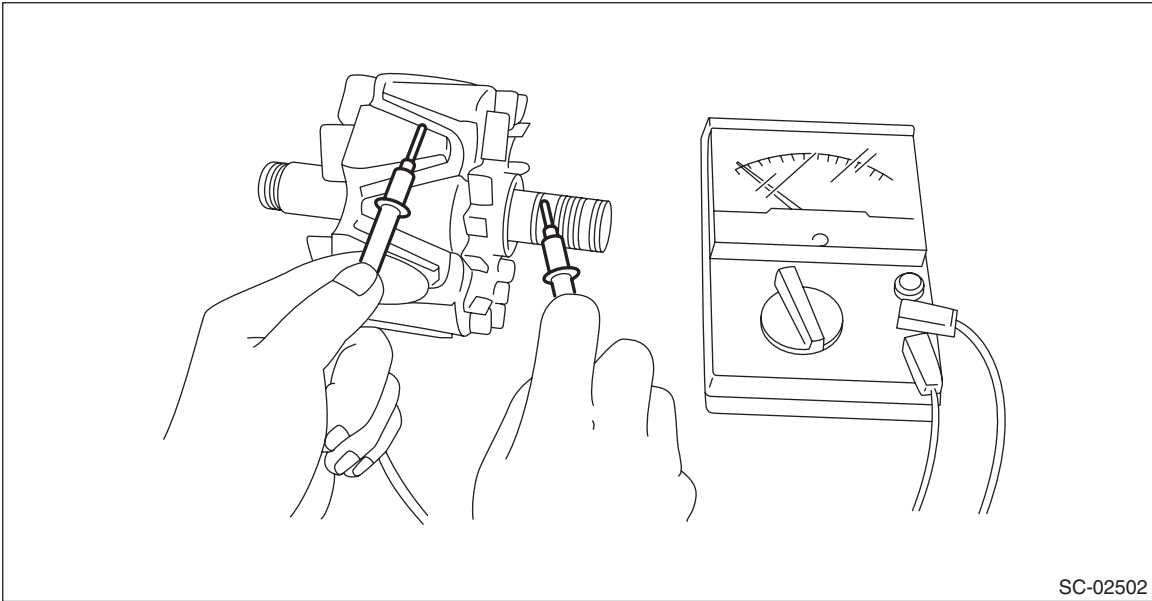

5) Bearing

Check the bearings. If there is any noise, or the rotor does not rotate smoothly, replace the bearings.

3. STATOR COIL

1) Continuity test

Inspect the continuity between the stator coil terminals. If continuity is not as shown in the table, replace the stator coil.

(A)						
1	2	3	4	5	6	
○	—	○				
○	—	—	○			
	○	—	○			
			○	—	○	
			○	—	—	○
				○	—	○

SC-02503

(A) Terminals

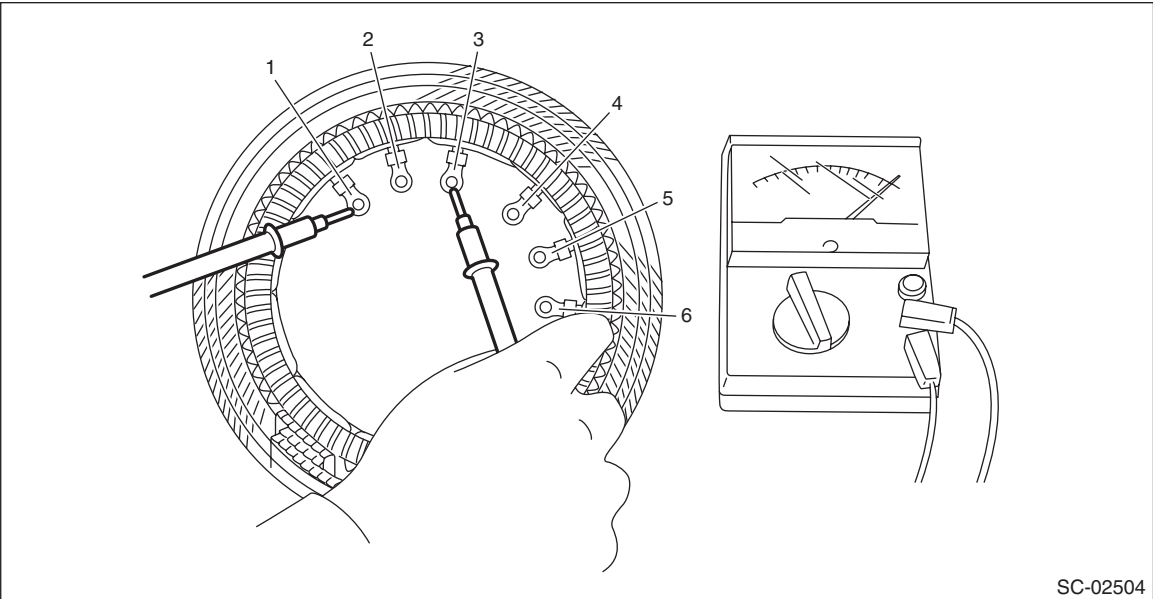

SC-02504

2) Insulation test

Inspect the continuity between the stator coil stator core and lead wire terminals. If there is continuity, replace the stator coil because the stator coil is grounded.

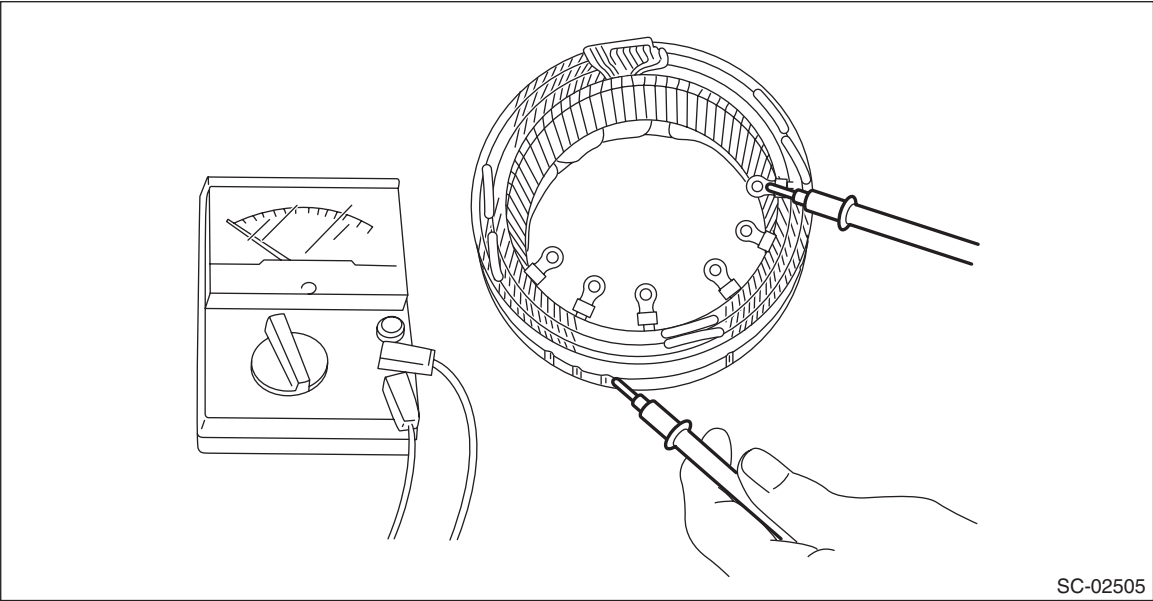

SC-02505

Generator

STARTING/CHARGING SYSTEMS

4. BRUSH

1) Measure the length of each brush. Replace the brush if wear exceeds service limits. There is a service limit mark (A) on each brush.

Brush length:

Standard (1)

18.5 mm (0.728 in)

Limit (2)

5.0 mm (0.197 in)

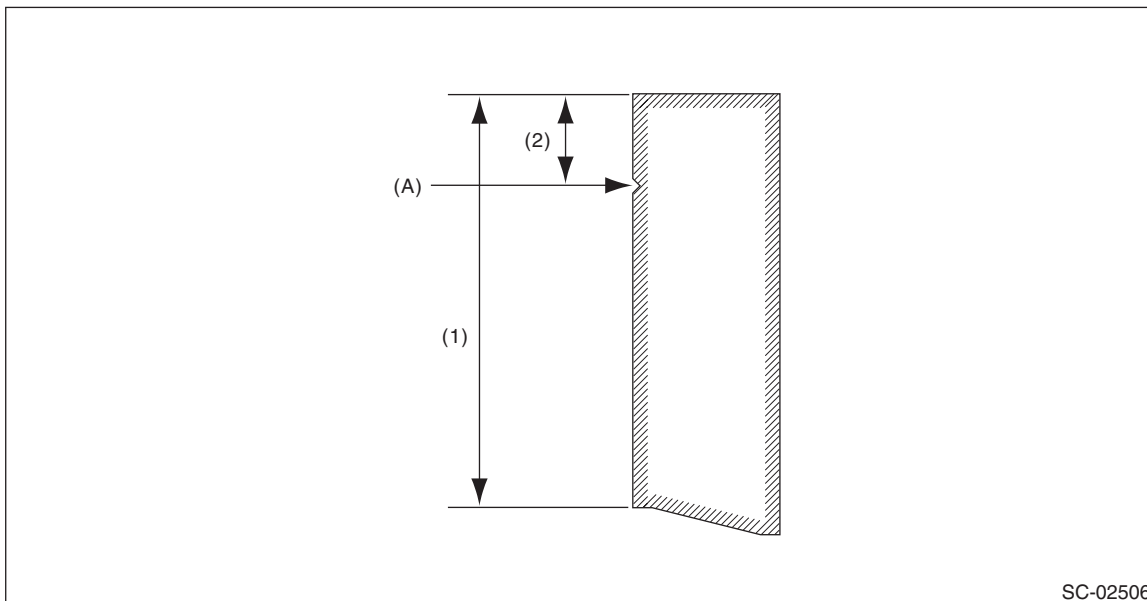

2) Check that there is appropriate pressure on the brush spring. Using a spring pressure indicator, push the brush into the brush holder until its tip protrudes 2 mm (0.0787 in). Then measure the pressure of brush spring. If the pressure is 1.7 N (173 gf, 6.11 ozf) or less, replace the brush spring. 4.1 — 5.3 N (418 — 540 gf, 14.75 — 19.06 ozf) pressure is required on the new spring.

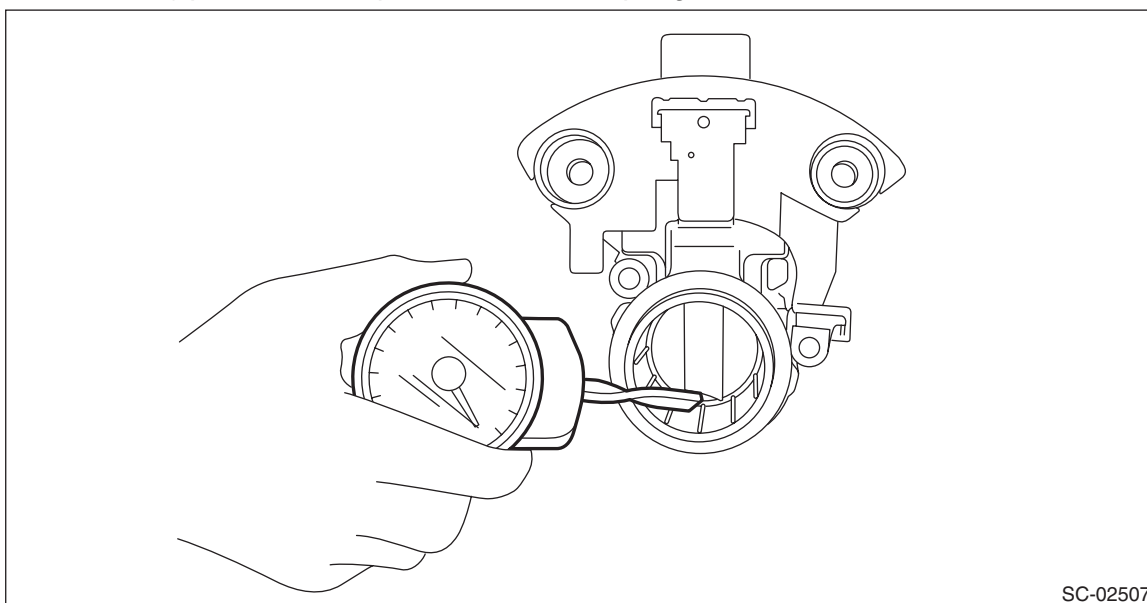

5. BALL BEARING

Check the ball bearings. Replace the ball bearings if there is resistance in the rotation, or if there is any abnormal noise.