

DTC	Item	Condition
P2094	Exhaust Camshaft Position Actuator Control Circuit Low (Bank 2)	—
P2095	Exhaust Camshaft Position Actuator Control Circuit High (Bank 2)	—
P2101	Throttle Actuator Control Motor Circuit Range/Performance	—
P2102	Throttle Actuator Control Motor Circuit Low	—
P2103	Throttle Actuator Control Motor Circuit High	—
P2109	Throttle/Pedal Position Sensor "A" Minimum Stop Performance	—
P2119	Throttle Actuator Control Throttle Body Range/Performance	—
P2122	Throttle/Pedal Position Sensor/Switch "D" Circuit Low Input	—
P2123	Throttle/Pedal Position Sensor/Switch "D" Circuit High Input	—
P2127	Throttle/Pedal Position Sensor/Switch "E" Circuit Low Input	—
P2128	Throttle/Pedal Position Sensor/Switch "E" Circuit High Input	—
P2135	Throttle/Pedal Position Sensor/Switch "A"/"B" Voltage Correlation	—
P2138	Throttle/Pedal Position Sensor/Switch "D"/"E" Voltage Correlation	—
P2195	O2 Sensor Signal Biased/Stuck Lean (Bank 1 Sensor 1)	—
P2196	O2 Sensor Signal Biased/Stuck Rich (Bank 1 Sensor 1)	—
P2401	Evaporative Emission System Leak Detection Pump Control Circuit Low	—
P2419	Evaporative Emission System Switching Valve Control Circuit Low	—
U0073	Control Module Communication Bus "A" Off	—
U0101	Lost Communication With TCM	—
U0122	Lost Communication With Vehicle Dynamics Control Module	—
U0155	Lost Communication With Instrument Panel Cluster (IPC) Control Module	—
U0402	Invalid Data Received From TCM	—
U0416	Invalid Data Received From Vehicle Dynamics Control Module	—
U0423	Invalid Data Received From Instrument Panel Cluster Control Module	—

1. PREPARATION FOR THE INSPECTION MODE

1) Check that the battery voltage is 12 V or more and fuel remains approx. half [20 — 40 L (5.3 — 10.6 US gal, 4.4 — 8.8 Imp gal)].

2) Lift up the vehicle using a garage jack and place it on rigid racks, or drive the vehicle onto free rollers.

WARNING:

- Before lifting up the vehicle, ensure parking brake is applied.
- Do not use a pantograph jack in place of a rigid rack.
- Secure a rope or wire to the front or rear towing hooks to prevent the lateral runout of front wheels.
- Before rotating the wheels, make sure that there is no one in front of the vehicle. Besides while the wheels are rotating, make sure that no one approaches the vehicle front side.
- Make sure that there is nothing around the wheels. For AWD model, pay attention to all four wheels.
- While servicing, do not depress or release the clutch pedal or accelerator pedal quickly regardless of the engine speed. Quick operation may cause the vehicle to drop off the free roller.

- To prevent the vehicle from slipping due to vibration, do not place anything between rigid rack and the vehicle.

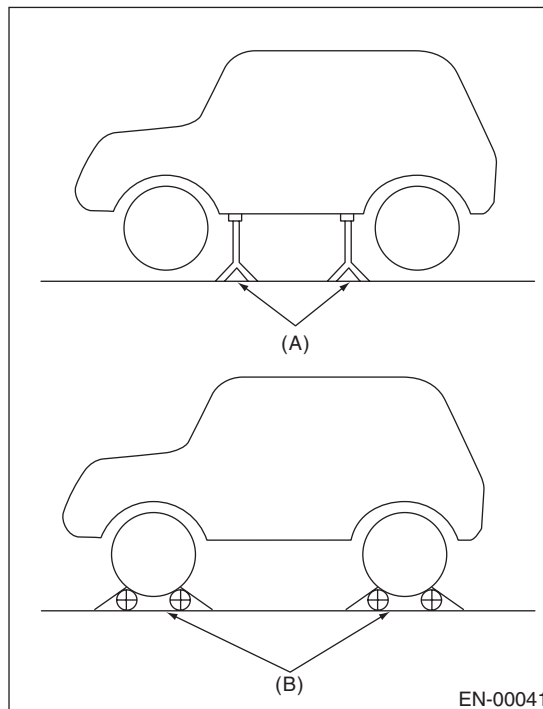

(A) Rigid rack
(B) Free roller

Inspection Mode

ENGINE (DIAGNOSTICS)

2. SUBARU SELECT MONITOR

1) Check that no DTC remains after clearing memory. <Ref. to EN(H4DO)(diag)-57, Clear Memory Mode.>

2) Warm up the engine.

3) Prepare the Subaru Select Monitor kit. <Ref. to EN(H4DO)(diag)-8, PREPARATION TOOL, General Description.>

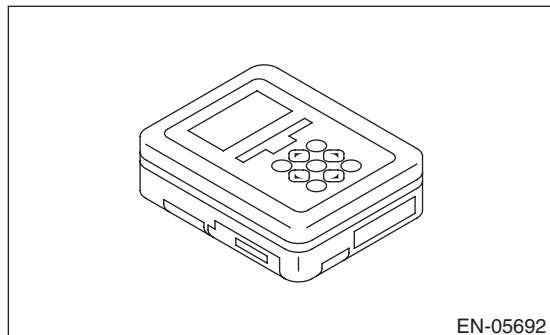

4) Prepare PC with Subaru Select Monitor installed.

5) Connect the USB cable to SDI (Subaru Diagnosis Interface) and USB port on the personal computer (dedicated port for the Subaru Select Monitor).

NOTE:

The dedicated port for the Subaru Select Monitor means the USB port which was used to install the Subaru Select Monitor.

6) Connect the diagnosis cable to SDI.

7) Install the delivery (test) mode fuse (A).

CAUTION:

Do not use any fuses that are installed on the vehicle.

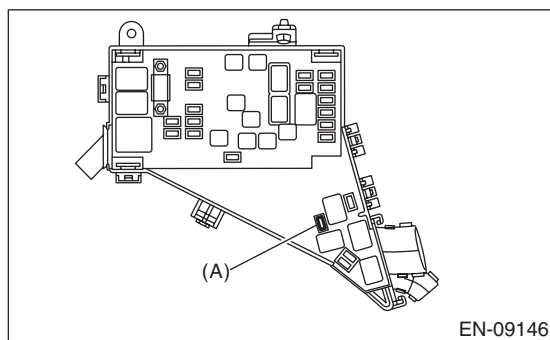

8) Connect SDI to data link connector located in the lower portion of the instrument panel (on the driver's side).

CAUTION:

Do not connect the scan tools except for Subaru Select Monitor and general scan tool.

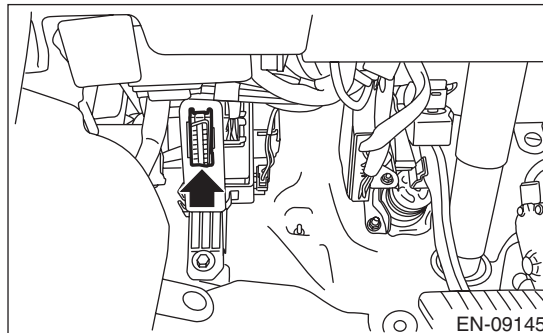

9) Start the PC.

10) Turn the ignition switch to ON (engine OFF) and run the "PC application for Subaru Select Monitor".

11) On «Main Menu» display, select {Each System Check}.

12) On «System Selection Menu» display, select {Engine Control System}.

13) Click the [OK] button after the information of engine type has been displayed.

14) On «Engine Diagnosis» display, select {Dealer Check Mode Procedure}.

15) When the "Perform Inspection (Dealer Check) Mode ?" is shown on the screen, click the [Next] button.

16) Perform subsequent procedures as instructed on the display screen.

• If trouble still remains in the memory, the corresponding DTC appears on the display screen.

NOTE:

• For detailed operation procedures, refer to "PC application help for Subaru Select Monitor".

• For details concerning DTC, refer to "List of Diagnostic Trouble Code (DTC)".

<Ref. to EN(H4DO)(diag)-82, List of Diagnostic Trouble Code (DTC).>

• Release the parking brake.

• The rotating speed difference between front and rear wheels may illuminate the warning light, but this does not indicate a malfunction. When engine control system diagnosis is finished, perform the VDC memory clearance procedure of self-diagnosis function. <Ref. to VDC(diag)-24, Clear Memory Mode.>

3. GENERAL SCAN TOOL

1) Check that no DTC remains after clearing memory. <Ref. to EN(H4DO)(diag)-57, Clear Memory Mode.>

2) Warm up the engine.

3) Install the delivery (test) mode fuse (A).

CAUTION:

Do not use any fuses that are installed on the vehicle.

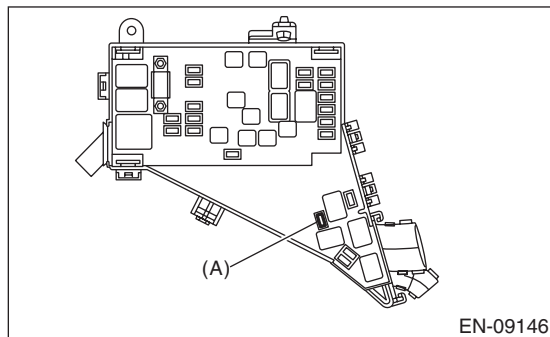

4) Connect the general scan tool to data link connector located in the lower portion of the instrument panel (on the driver's side).

CAUTION:

Do not connect the scan tools except for Subaru Select Monitor and general scan tool.

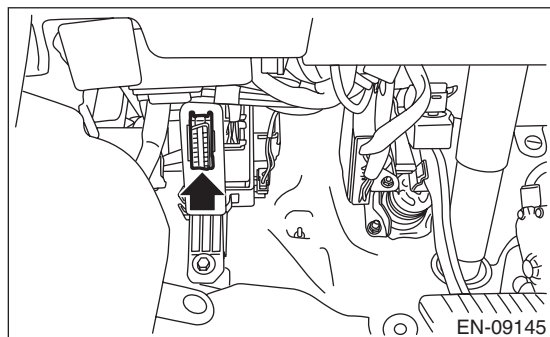

5) Start the engine.

NOTE:

- Ensure the selector lever is placed in the "P" range before starting. (CVT model)
- Depress the clutch pedal when starting engine. (MT model)

6) Turn the neutral position switch to ON using select lever or shift lever.

7) Depress the brake pedal to turn the brake switch ON. (CVT model)

8) Keep the engine speed in 2,500 — 3,000 rpm range for 40 seconds.

9) Place the select lever or shift lever in "D" position (CVT model) or "1st gear" (MT model) and drive the vehicle at 5 to 10 km/h (3 to 6 MPH).

NOTE:

- For AWD model, release the parking brake.
- The rotating speed difference between front and rear wheels may illuminate the ABS warning light, but this does not indicate a malfunction. When engine control system diagnosis is finished, perform the VDC memory clearance procedure of self-diagnosis function. <Ref. to VDC(diag)-24, Clear Memory Mode.>

10) Using the general scan tool, check for DTC and record the result(s).

NOTE:

- For detailed operation procedures, refer to the general scan tool operation manual.
- For details concerning DTC, refer to "List of Diagnostic Trouble Code (DTC)". <Ref. to EN(H4DO)(diag)-82, List of Diagnostic Trouble Code (DTC).>