

11. Transmission Mounting System

A: REMOVAL

1. PITCHING STOPPER

- 1) Disconnect the ground cable from battery.
- 2) Remove the air intake boot assembly. <Ref. to IN(H4DO)-12, REMOVAL, Air Intake Boot.>
- 3) Remove the pitching stopper.

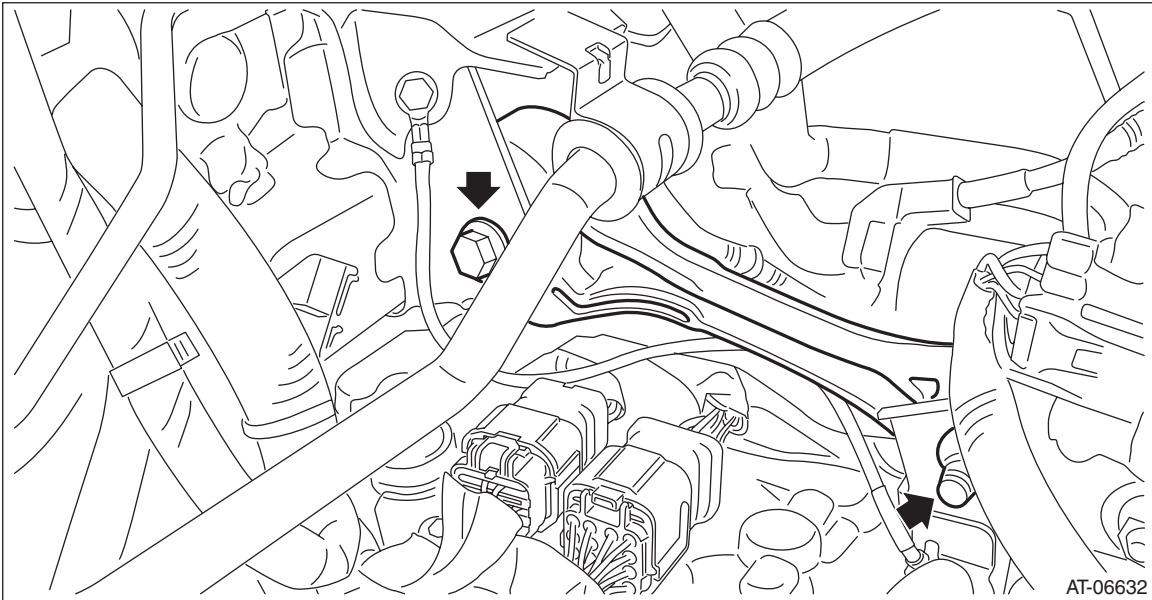

2. TRANSMISSION REAR CROSSMEMBER AND REAR CUSHION RUBBER

- 1) Disconnect the ground cable from battery.
- 2) Lift up the vehicle.
- 3) Remove the center exhaust pipe. <Ref. to EX(H4DO)-14, REMOVAL, Center Exhaust Pipe.>
- 4) Remove the center exhaust cover.

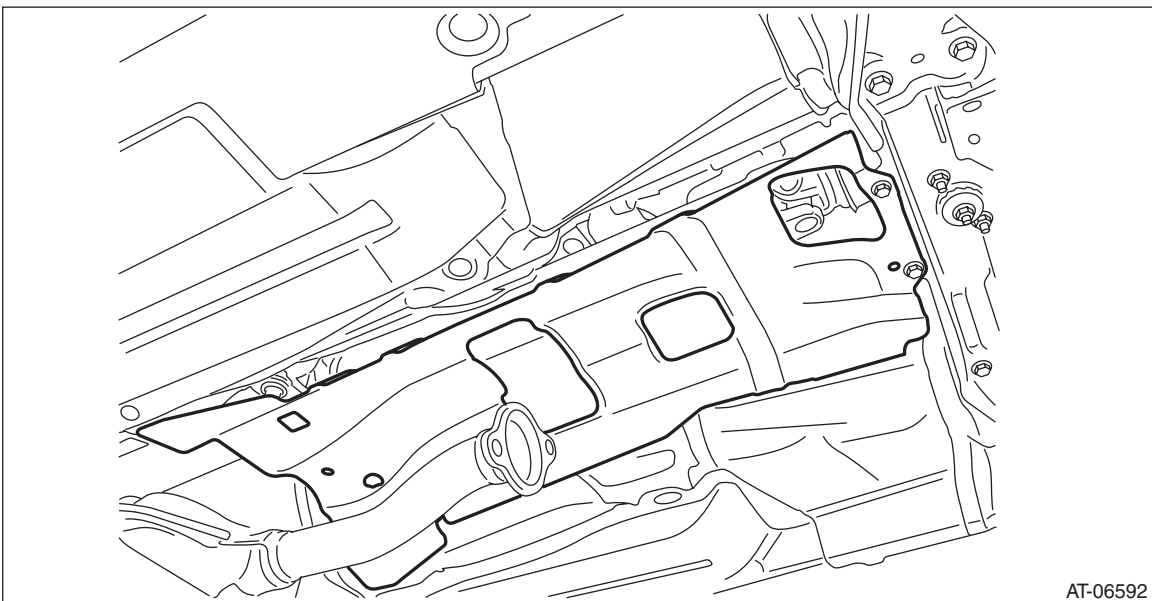

- 5) Set the transmission jack under the transmission. Make sure that the support plate of transmission jack does not touch the oil pan.

Transmission Mounting System

CONTINUOUSLY VARIABLE TRANSMISSION

6) Remove the transmission rear crossmember.

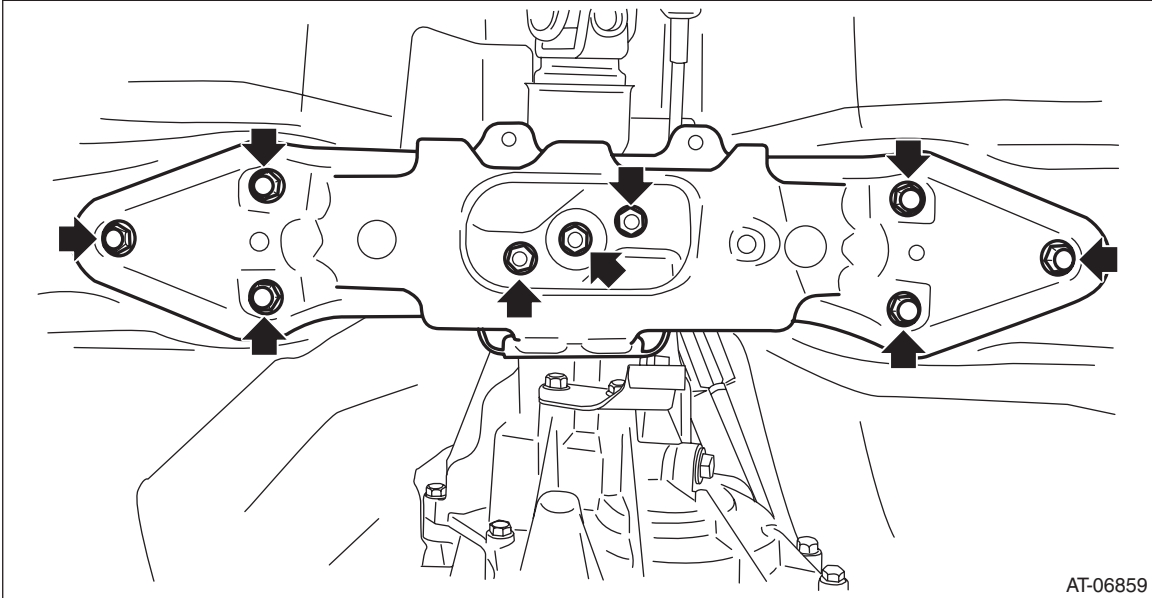

7) Remove the rear cushion rubber.

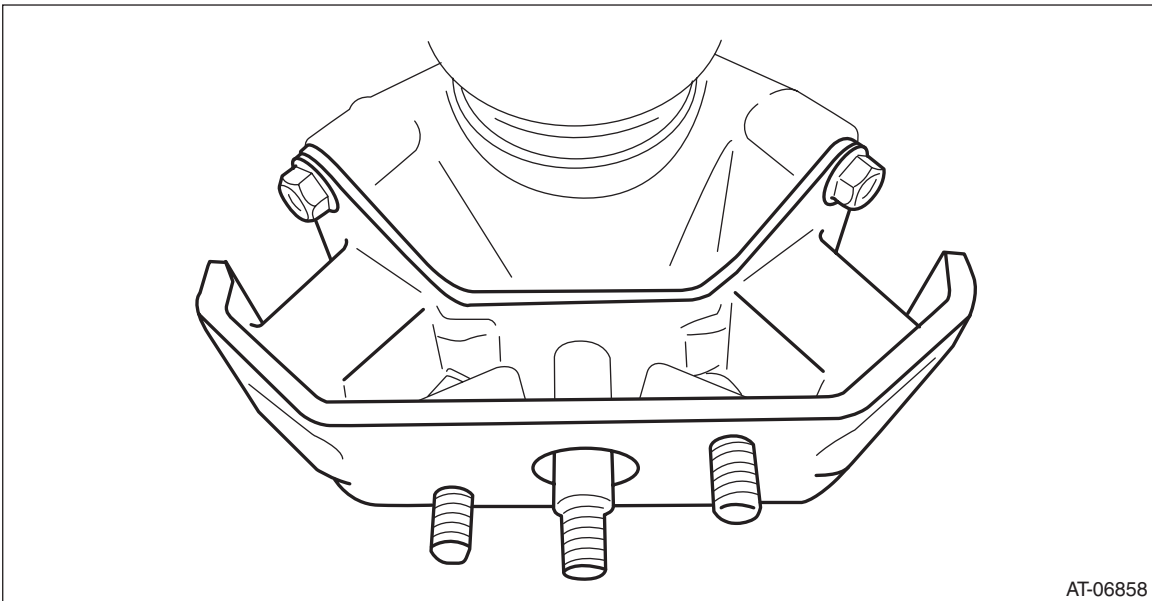

B: INSTALLATION

1. PITCHING STOPPER

1) Install the pitching stopper.

Tightening torque:

T1: 50 N·m (5.1 kgf-m, 36.9 ft-lb)

T2: 58 N·m (5.9 kgf-m, 42.8 ft-lb)

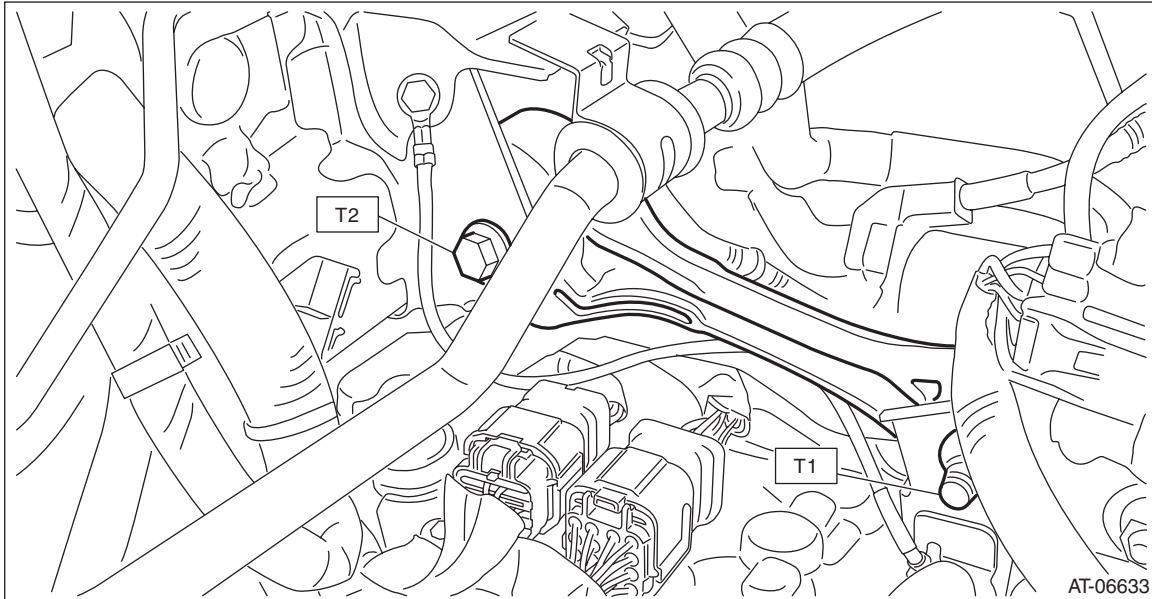

2) Install the air intake boot assembly. <Ref. to IN(H4DO)-12, INSTALLATION, Air Intake Boot.>
3) Connect the battery ground terminal.

2. TRANSMISSION REAR CROSSMEMBER AND REAR CUSHION RUBBER

1) Attach the rear cushion rubber to the transmission.

Tightening torque:

40 N·m (4.1 kgf-m, 29.5 ft-lb)

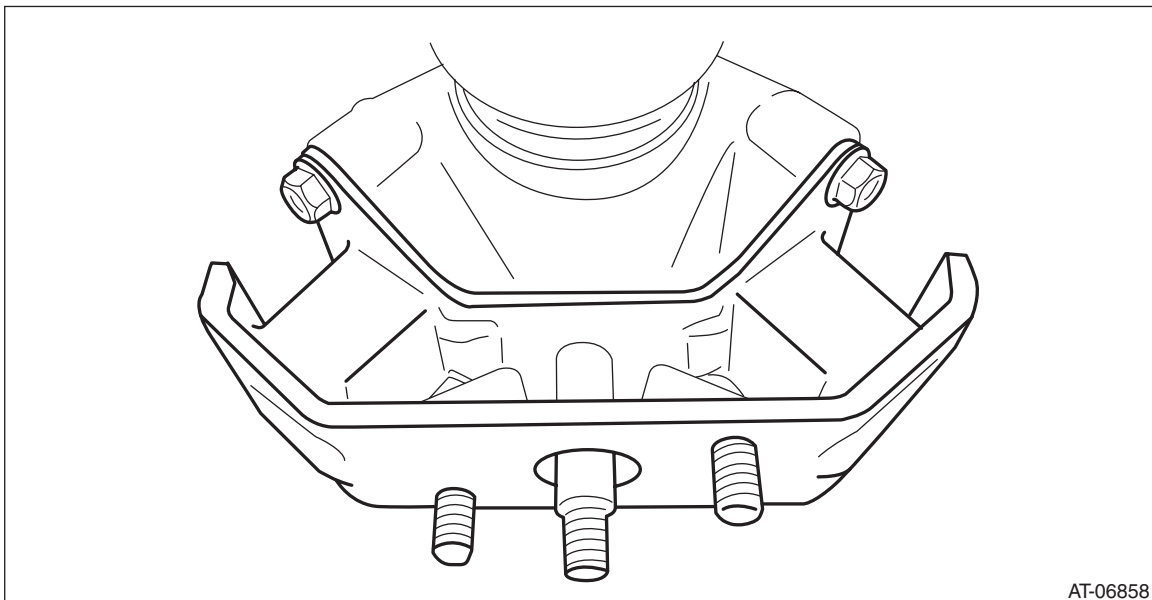

Transmission Mounting System

CONTINUOUSLY VARIABLE TRANSMISSION

2) Install the crossmember.

Tightening torque:

T1: 35 N·m (3.6 kgf-m, 25.8 ft-lb)

T2: 70 N·m (7.1 kgf-m, 51.6 ft-lb)

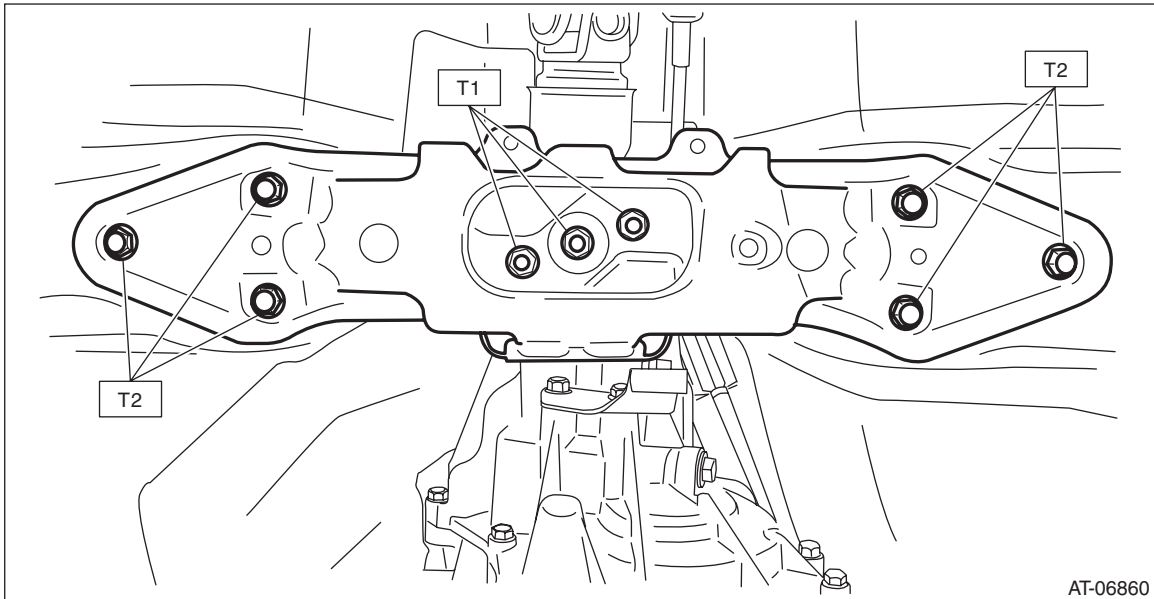

3) Remove the transmission jack.

4) Install the center exhaust cover.

Tightening torque:

18 N·m (1.8 kgf-m, 13.3 ft-lb)

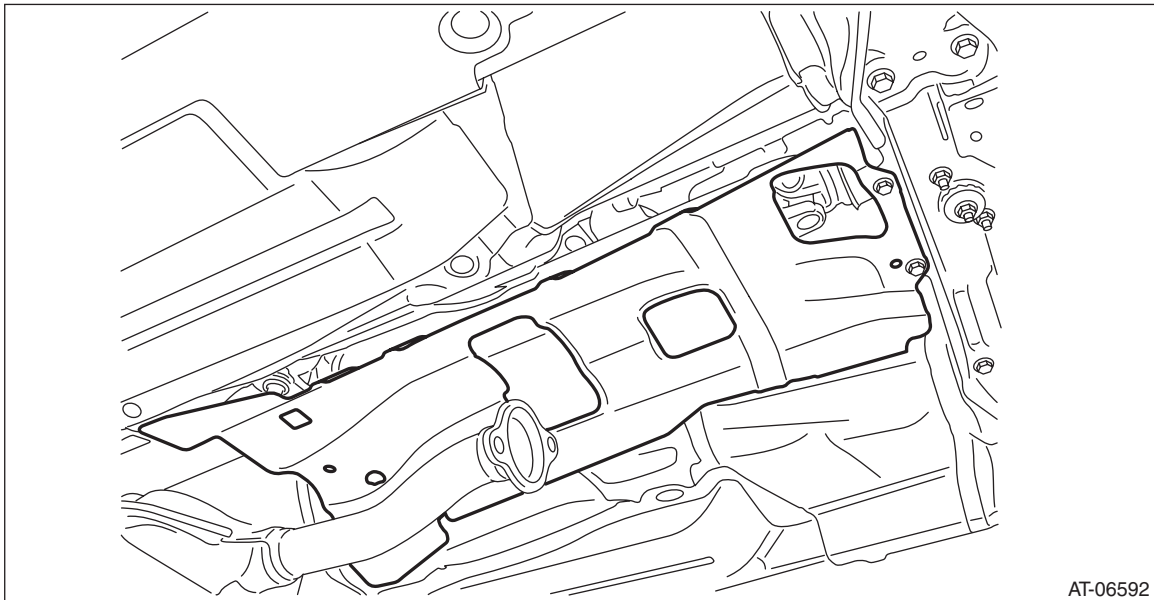

5) Install the center exhaust pipe. <Ref. to EX(H4DO)-14, INSTALLATION, Center Exhaust Pipe.>

6) Connect the battery ground terminal.

C: INSPECTION

- Check the crossmember for bends or damage.
- Check that the cushion rubber is not stiff, cracked or otherwise damaged.