

## 13. Differential Side Retainer Oil Seal

### A: INSPECTION

Check for leakage of gear oil from differential side retainer oil seal part. If there is an oil leak, inspect the front drive shaft and replace the oil seal.

### B: REPLACEMENT

#### CAUTION:

- Immediately after the vehicle has been running or after idling for a long time, the differential gear oil will be hot. Be careful not to burn yourself.
- Be careful not to spill the differential gear oil on exhaust pipe to prevent it from emitting smoke or fire. If differential gear oil is spilled on the exhaust pipe, wipe it off completely.

- 1) Remove the front wheels. <Ref. to WT-4, REMOVAL, Tire and Wheel.>
- 2) Remove the center exhaust pipe. <Ref. to EX(H4DO)-14, REMOVAL, Center Exhaust Pipe.>
- 3) Remove the differential gear oil drain plug using TORX® bit T70, and then drain differential gear oil.

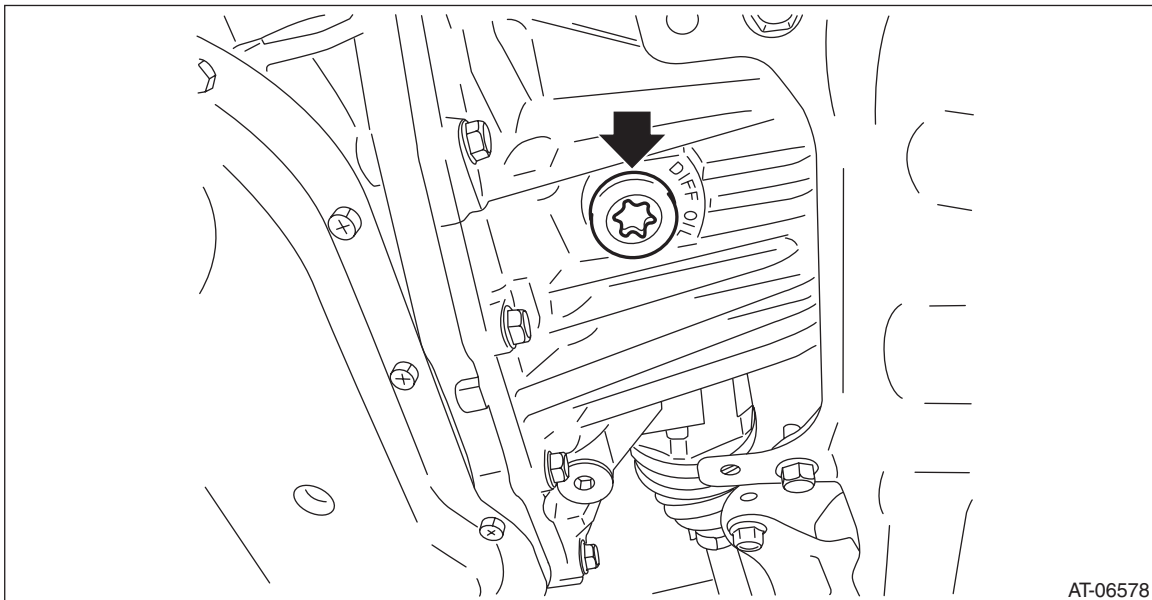

## Differential Side Retainer Oil Seal

CONTINUOUSLY VARIABLE TRANSMISSION

4) Tighten the differential gear oil drain plug.

NOTE:

Use a new gasket.

**Tightening torque:**

**70 N·m (7.1 kgf·m, 51.6 ft·lb)**

5) Remove the jack-up plate.

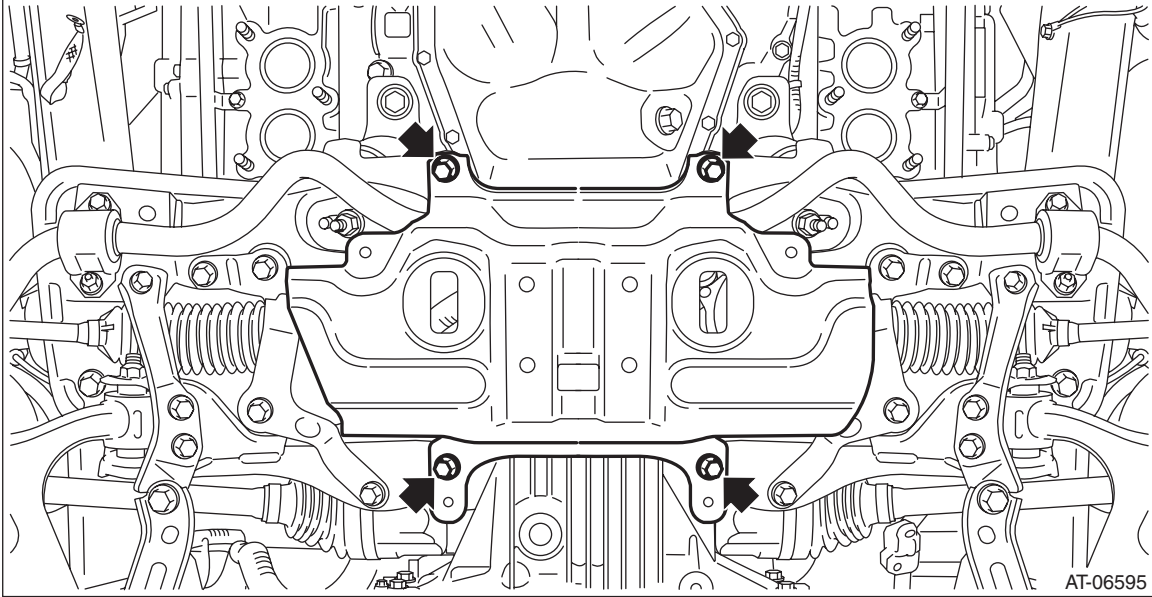

6) Remove the stabilizer bracket.

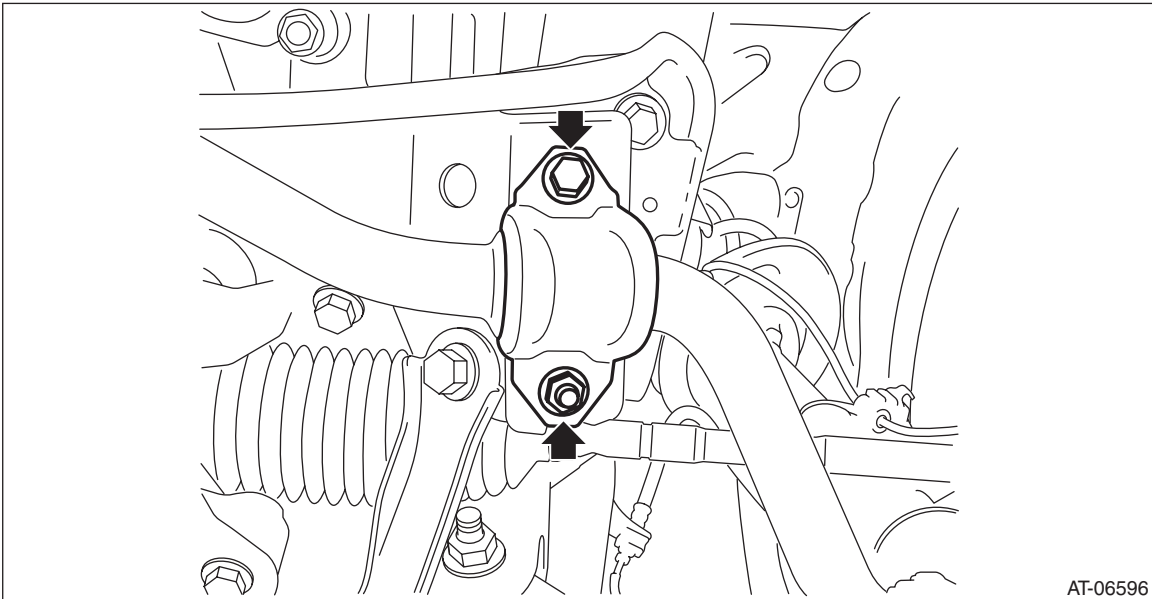

# Differential Side Retainer Oil Seal

CONTINUOUSLY VARIABLE TRANSMISSION

7) Remove the bolts which secure to the front housing, and separate the front arm and housing.

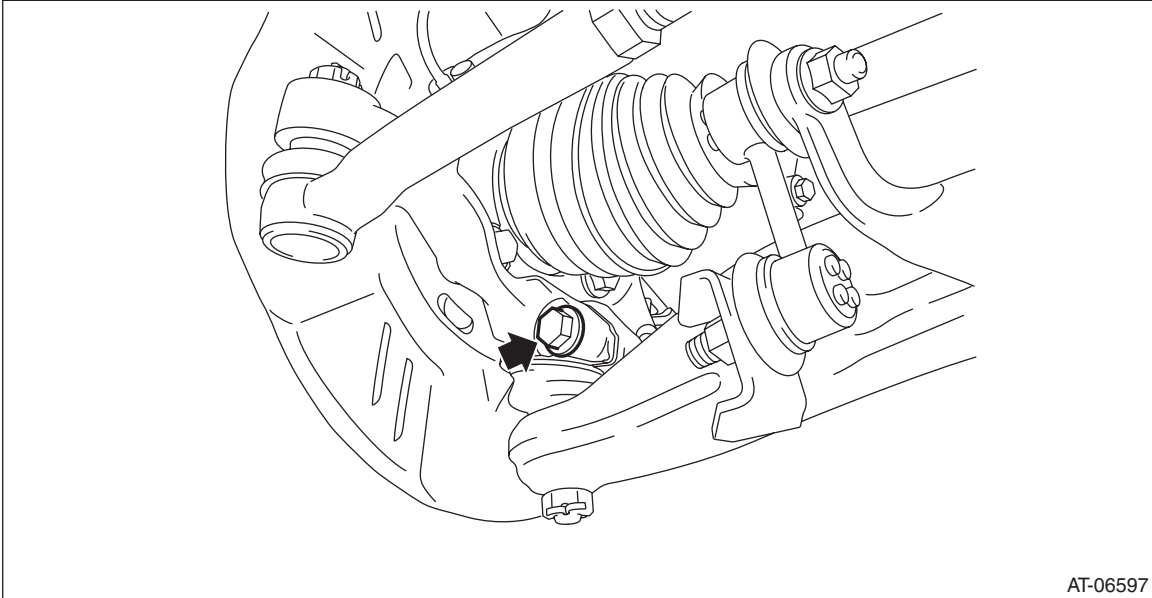

8) Using a crowbar, etc., pull out until the front drive shaft transmission side joint slides move smoothly.

**NOTE:**

Place cloth between the crowbar and the transmission in order to avoid damaging the transmission side retainer.

9) Hold the transmission side joint of the front drive shaft by hand and extract the housing from the transmission while pressing the housing outward, so as not to stretch the boot.

**NOTE:**

- Before pulling RH front drive shaft from transmission, turn the steering wheel to left hand full lock.
- Before pulling LH front drive shaft from transmission, turn the steering wheel to right hand full lock.

10) Remove the differential side retainer oil seal using driver wrapped with vinyl tape etc.

11) Using the ST, install the differential side retainer oil seal by lightly tapping with a hammer.

**NOTE:**

- Apply differential gear oil to the lip surface, so that the oil seal lip is not deformed.
- Apply differential gear oil to the press-fitting surface of oil seal and the differential side retainer.
- Oil seal has an identification mark (R, L). When installing oil seals, do not confuse the left and right.

ST 18675AA000 DIFFERENTIAL SIDE OIL SEAL INSTALLER

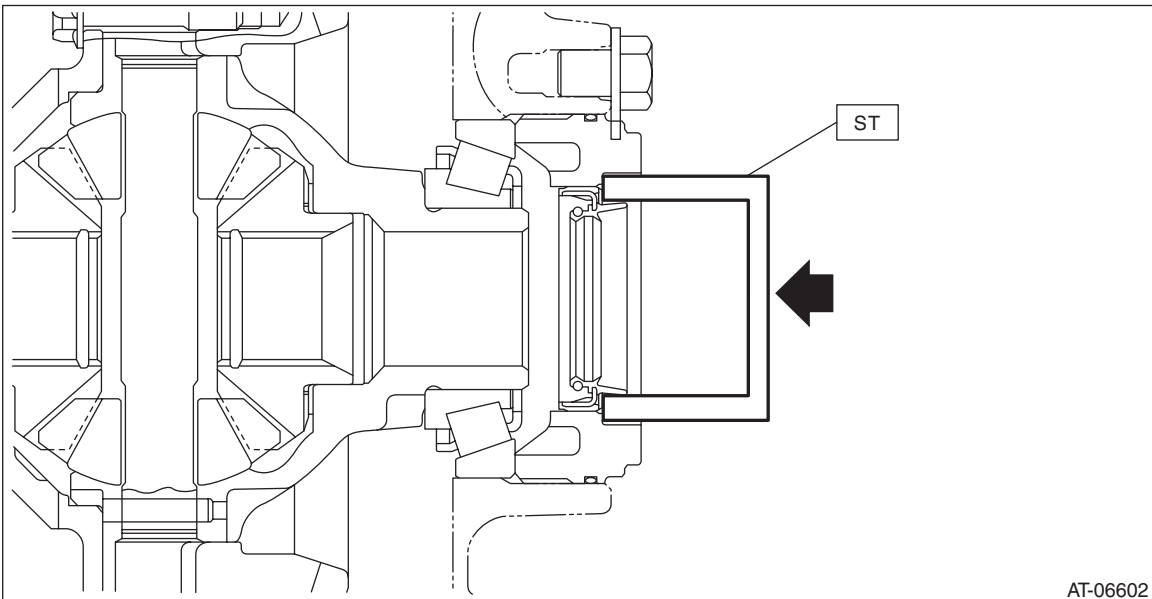

## Differential Side Retainer Oil Seal

CONTINUOUSLY VARIABLE TRANSMISSION

12) Set the ST to side retainer.

ST 28399SA010 OIL SEAL PROTECTOR

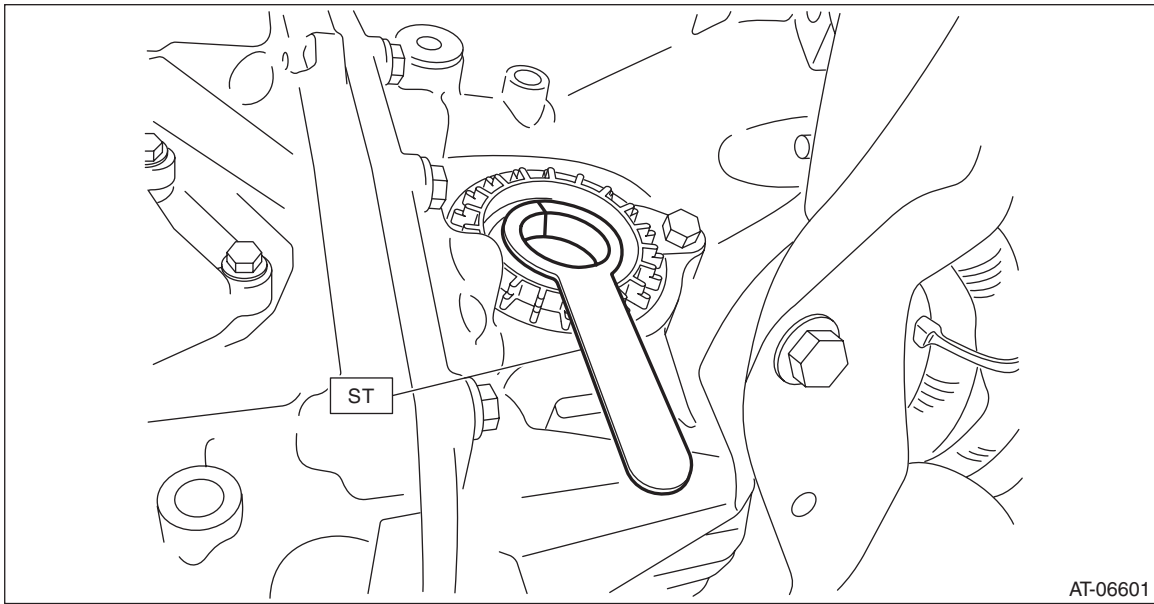

13) Replace the circlip of the drive shaft with a new part.

14) Insert the front drive shaft spline section into transmission and remove the ST (DIFFERENTIAL SIDE OIL SEAL INSTALLER).

NOTE:

- Apply grease to the side retainer oil seal lip.
- Before inserting RH front drive shaft into transmission, turn the steering wheel to left hand full lock.
- Before inserting LH front drive shaft into transmission, turn the steering wheel to right hand full lock.

15) Insert the drive shaft into the transmission securely by pressing the housing from outside of the vehicle.

16) Insert the ball joint into housing and secure with bolt.

**Tightening torque:**

**50 N·m (5.1 kgf·m, 36.9 ft·lb)**

**CAUTION:**

- Do not apply grease to the tapered portion of ball stud.
- Before tightening, make sure the lower side of housing and stepped section of ball joint are in contact.

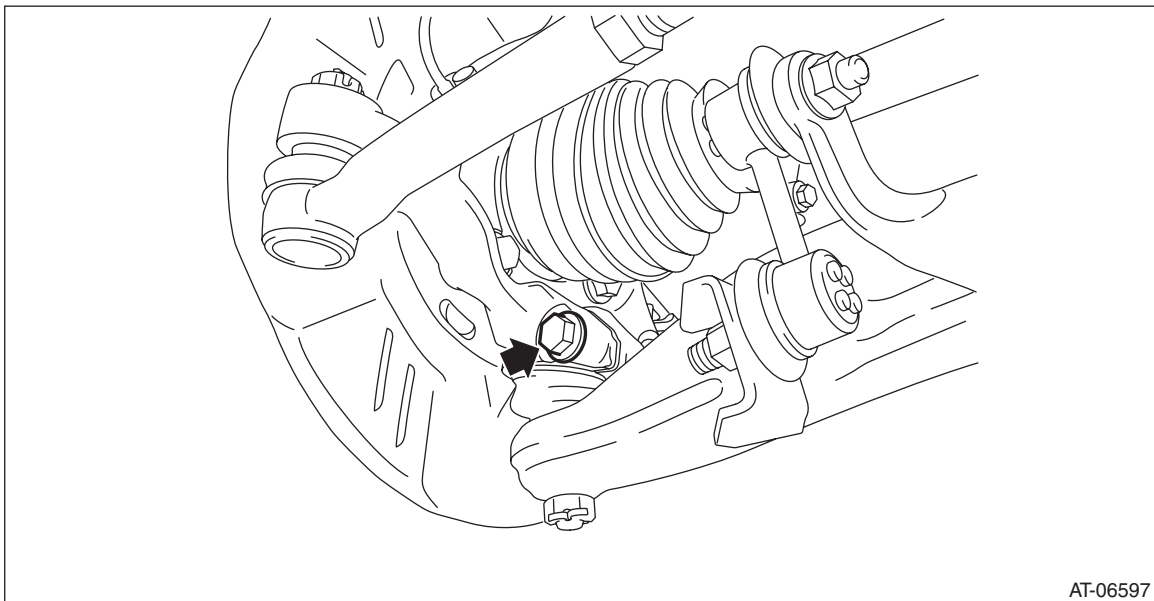

## Differential Side Retainer Oil Seal

CONTINUOUSLY VARIABLE TRANSMISSION

17) Install the stabilizer bracket.

**Tightening torque:**

**25 N·m (2.5 kgf·m, 18.4 ft·lb)**

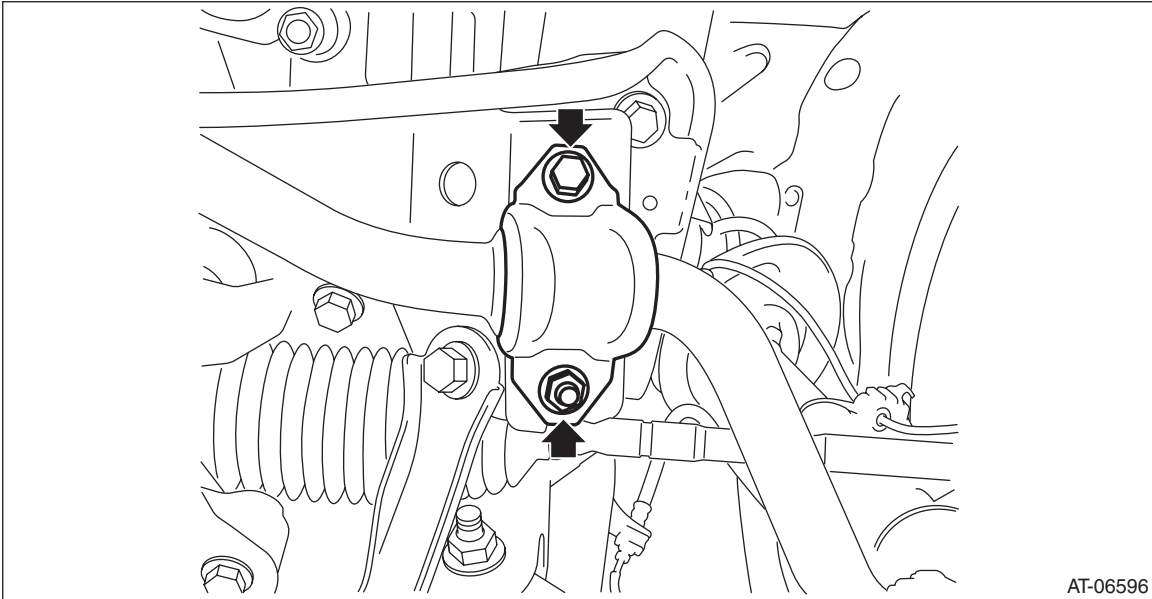

18) Install the jack-up plate.

**Tightening torque:**

**60 N·m (6.1 kgf·m, 44.3 ft·lb)**

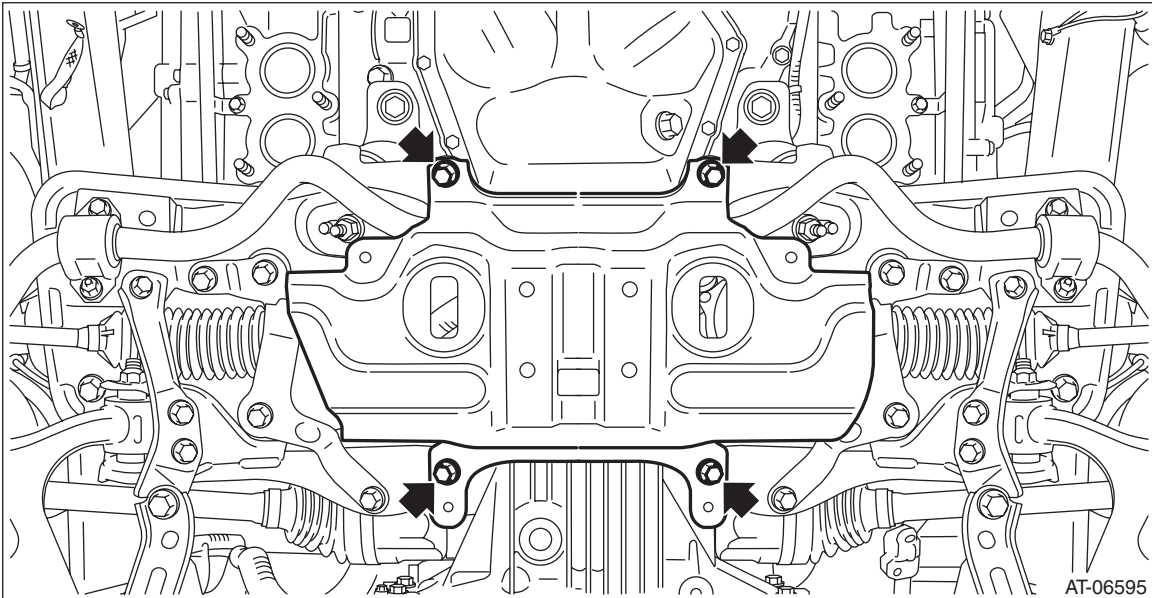

19) Install the center exhaust pipe. <Ref. to EX(H4DO)-14, INSTALLATION, Center Exhaust Pipe.>

20) Fill differential gear oil. <Ref. to CVT-39, Differential Gear Oil.>

21) Adjust the differential gear oil level, and check for leakage. <Ref. to CVT-39, ADJUSTMENT, Differential Gear Oil.>

22) Install the front wheels. <Ref. to WT-4, INSTALLATION, Tire and Wheel.>