

15. Turbine Speed Sensor

A: REMOVAL

CAUTION:

Be sure to prevent water or oil from contacting the connector terminal of turbine speed sensor. If adhesion occurs, replace with a new part.

- 1) Lift up the vehicle.
- 2) Remove the harness connector from turbine speed sensor.
- 3) Remove the turbine speed sensor.

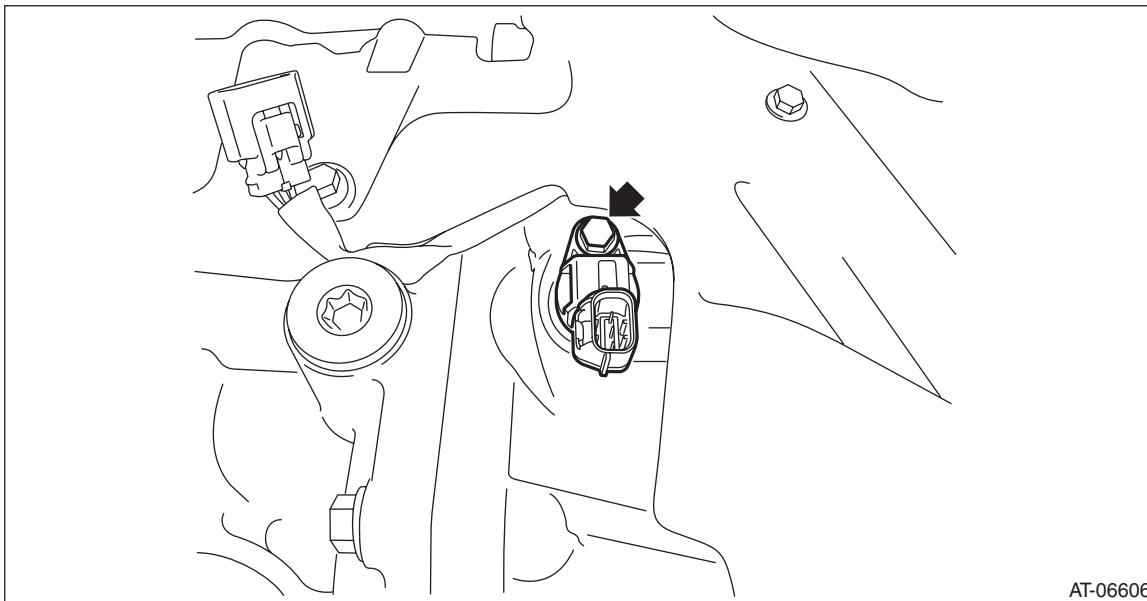

B: INSTALLATION

CAUTION:

Be sure to prevent water or oil from contacting the connector terminal of turbine speed sensor. If adhesion occurs, replace with a new part.

Install in the reverse order of removal.

NOTE:

- Use new O-rings.
- Apply CVTF to the O-ring.

Tightening torque:

7 N·m (0.7 kgf·m, 5.2 ft·lb)

Turbine Speed Sensor

CONTINUOUSLY VARIABLE TRANSMISSION

C: INSPECTION

- 1) Remove the instrument panel lower cover. <Ref. to EI-65, REMOVAL, Instrument Panel Lower Cover.>
- 2) Set the probe of oscilloscope to TCM harness connector.

Connector & terminal

(B54) No. 20 (+) — No. 1 (-):

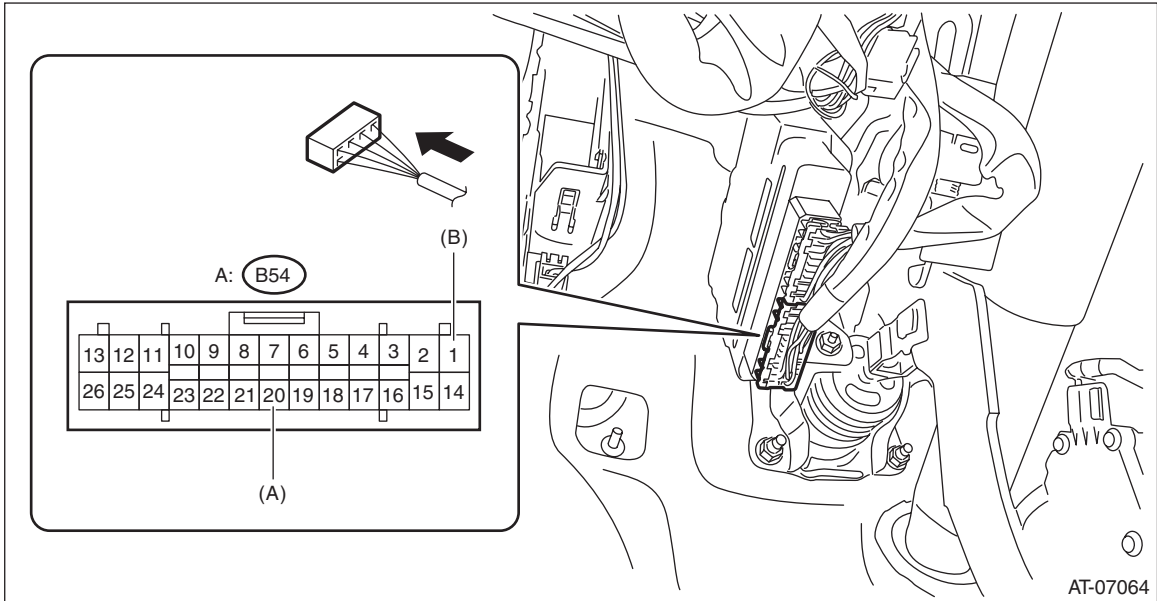

(A) + probe

(B) - probe

- 3) Start and warm up the engine.
- 4) Check the waveform and output voltage of the turbine speed sensor with engine idling.

