

Control Valve Body

CONTINUOUSLY VARIABLE TRANSMISSION

20. Control Valve Body

A: REMOVAL

CAUTION:

- Directly after the vehicle has been running or the engine has been idling for a long time, the CVTF is hot. Be careful not to burn yourself.
- Be careful not to spill CVTF on the exhaust pipe to prevent it from emitting smoke or causing a fire. If the CVTF adheres, wipe it off completely.
- Always clean the engine compartment before removal.

NOTE:

The control valve body is replaced as an assembly only, because it is a non-disassembly part.

- 1) Disconnect the ground cable from battery.
- 2) Remove the air intake boot assembly. <Ref. to IN(H4DO)-12, REMOVAL, Air Intake Boot.>
- 3) Disconnect the following connectors.
 - Transmission harness connectors
 - Inhibitor harness connector
 - Transmission radio ground terminal

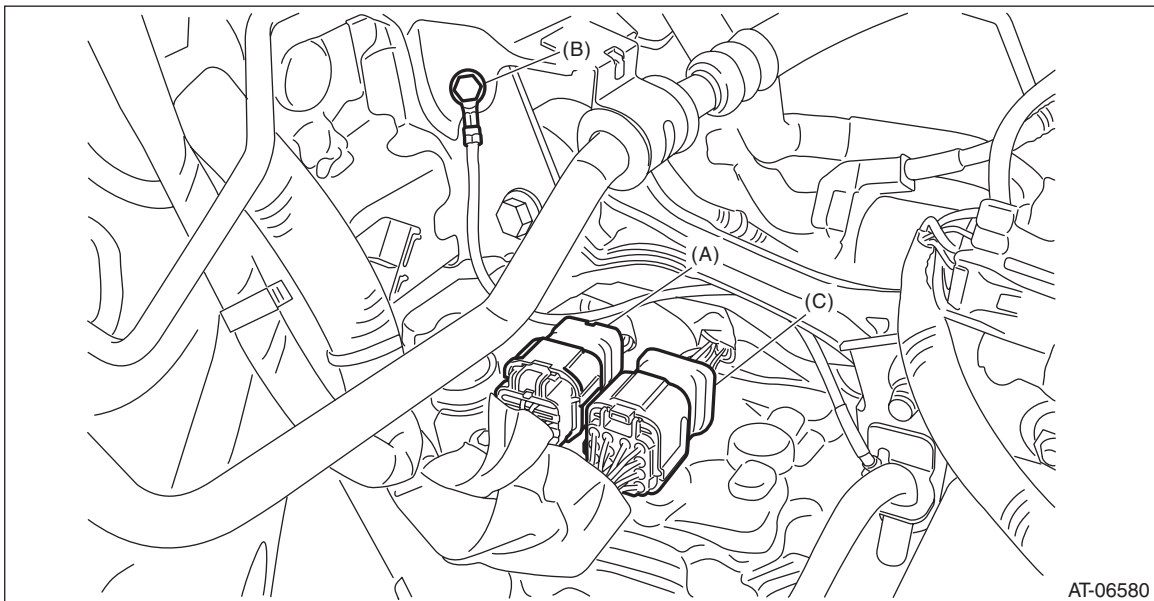

AT-06580

- (A) Transmission harness connectors
- (B) Transmission radio ground terminal
- (C) Inhibitor harness connector

Control Valve Body

CONTINUOUSLY VARIABLE TRANSMISSION

4) Remove the pitching stopper.

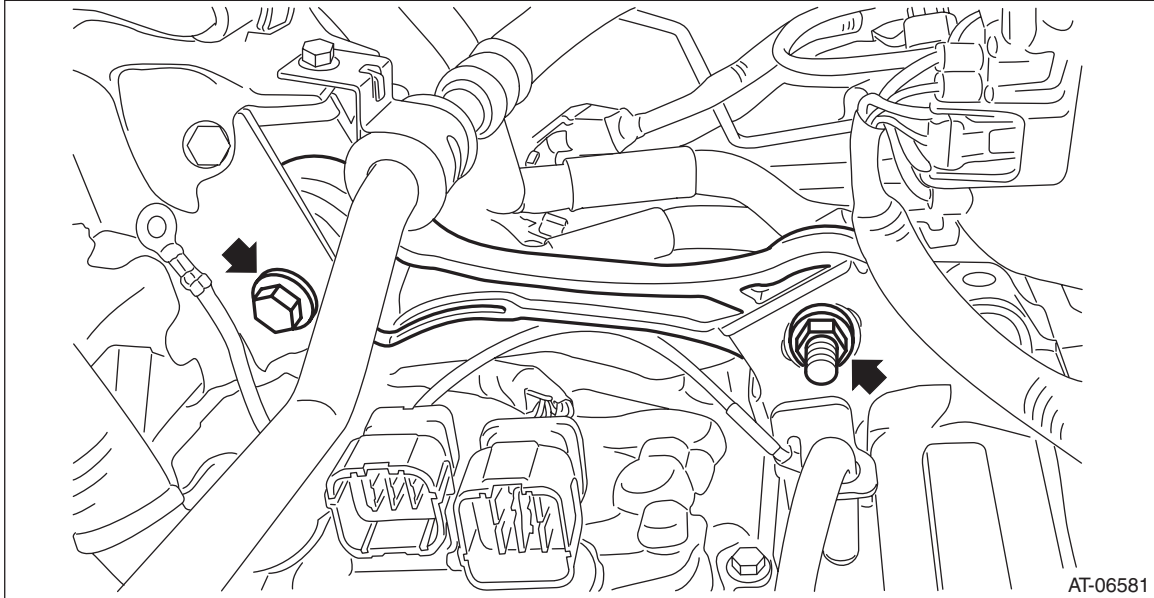

5) Remove the air breather hose from the pitching stopper bracket, and then remove the pitching stopper bracket and transmission radio ground cord.

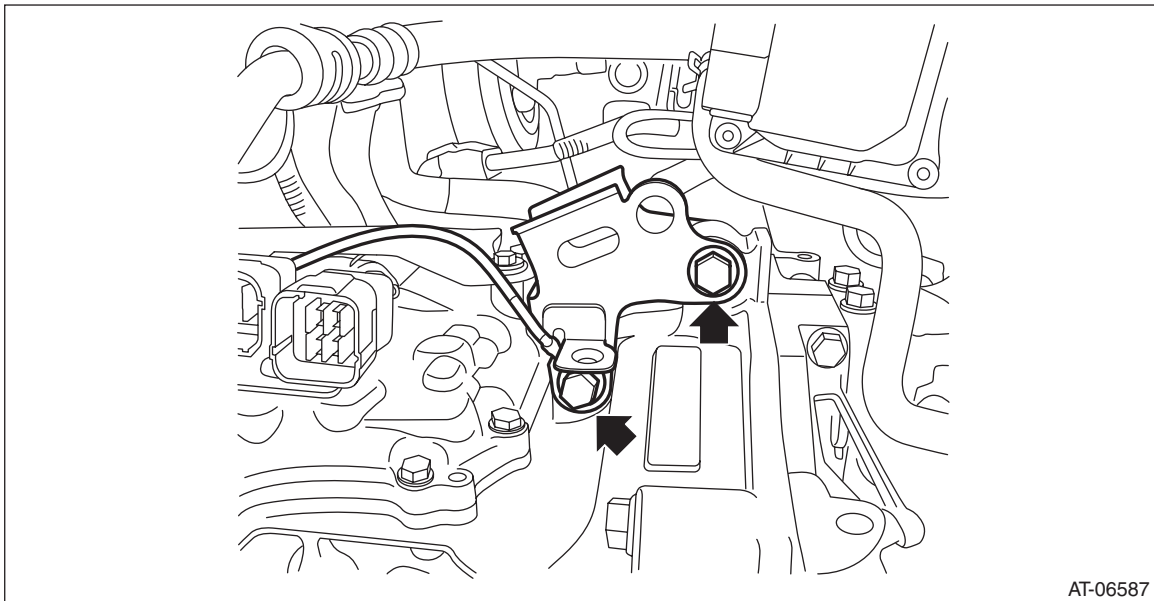

Control Valve Body

CONTINUOUSLY VARIABLE TRANSMISSION

6) Remove the transmission case cover.

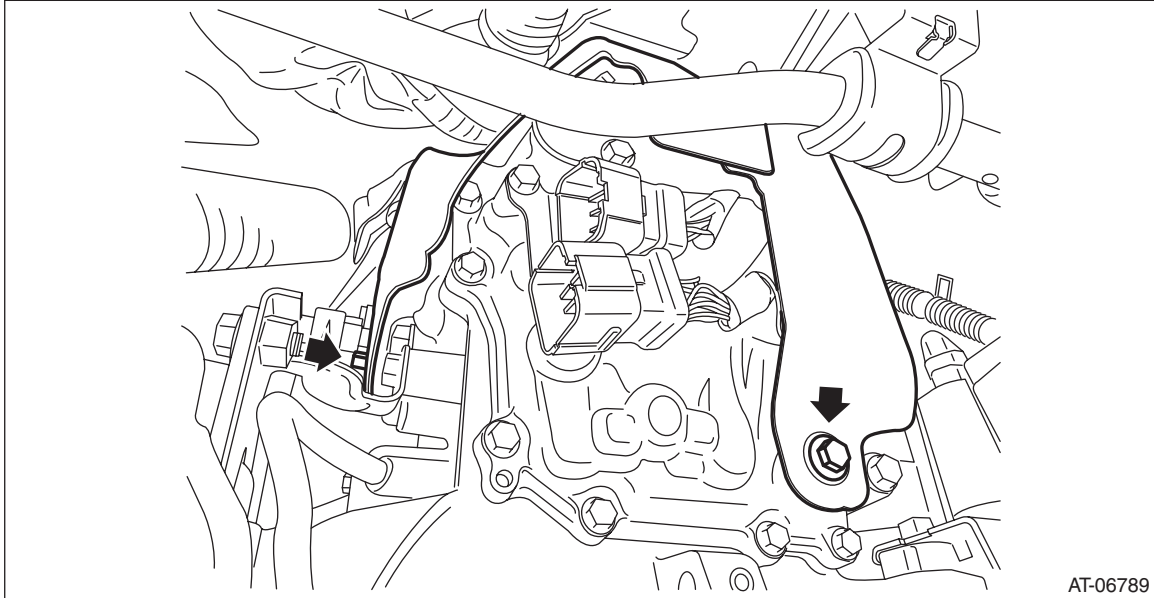

7) Remove the transmission harness stay and ground terminal.

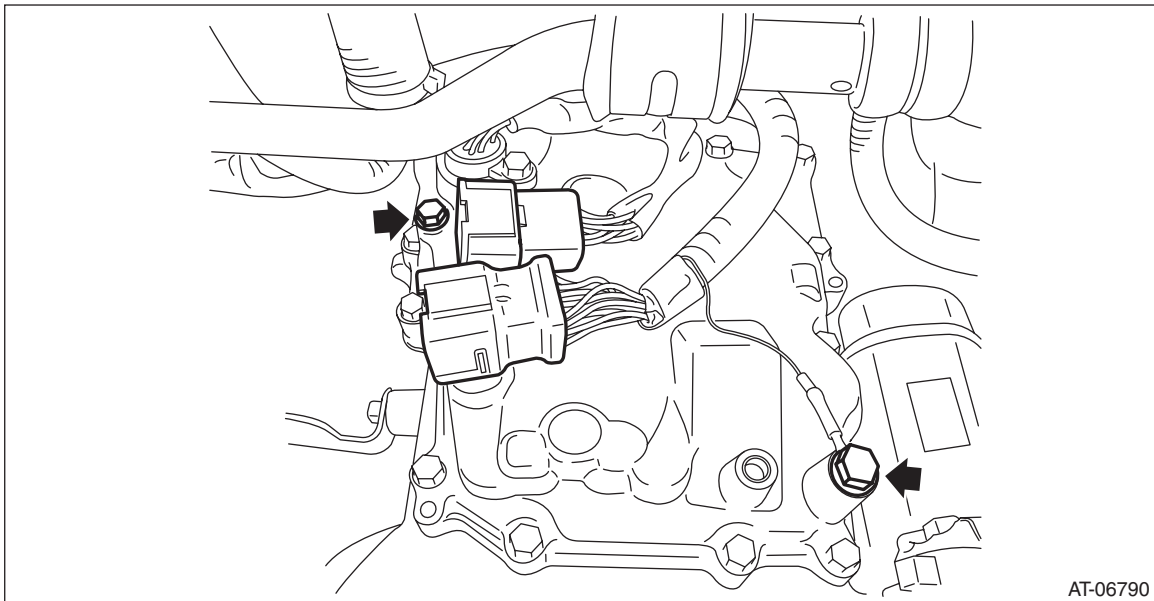

8) Remove the transmission harness connector from the harness stay.

9) Remove the throttle body, and move it aside so that it will not interfere with the removal of the control valve.
<Ref. to FU(H4DO)-18, REMOVAL, Throttle Body.>

NOTE:

Do not remove the preheater hose.

10) Clean the transmission exterior.

Control Valve Body

CONTINUOUSLY VARIABLE TRANSMISSION

11) Fix the ST with tape, and set the ST to the vehicle.

NOTE:

When replacing the control valve body, the sheet is included in the control valve body for repairs.

ST 18761AA010 SHEET SPECIAL TOOL

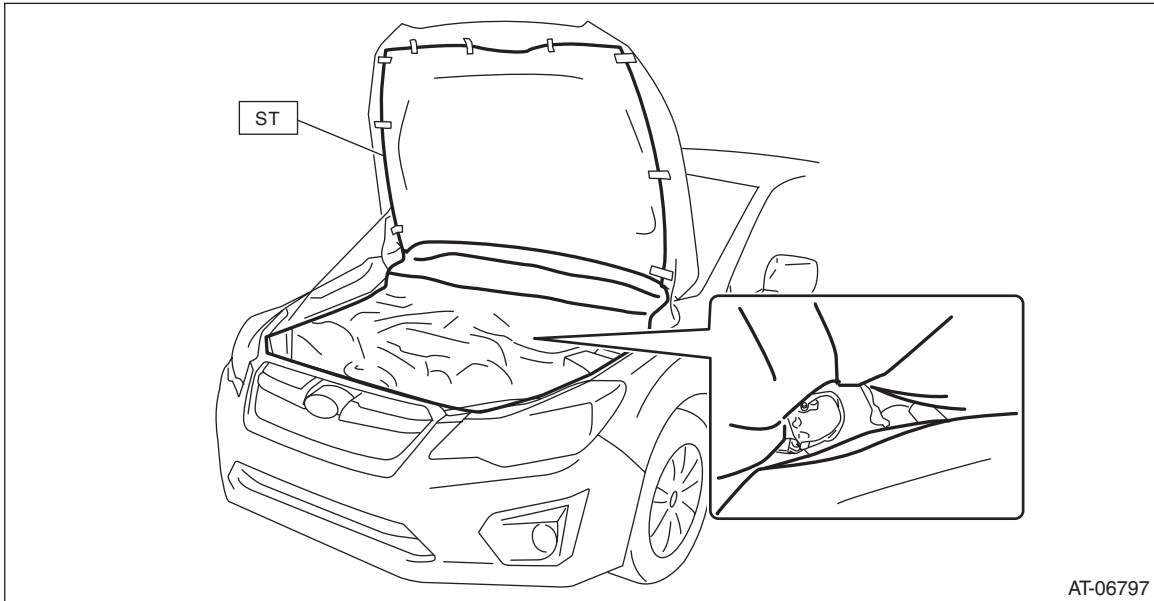

12) Remove the valve cover and gasket.

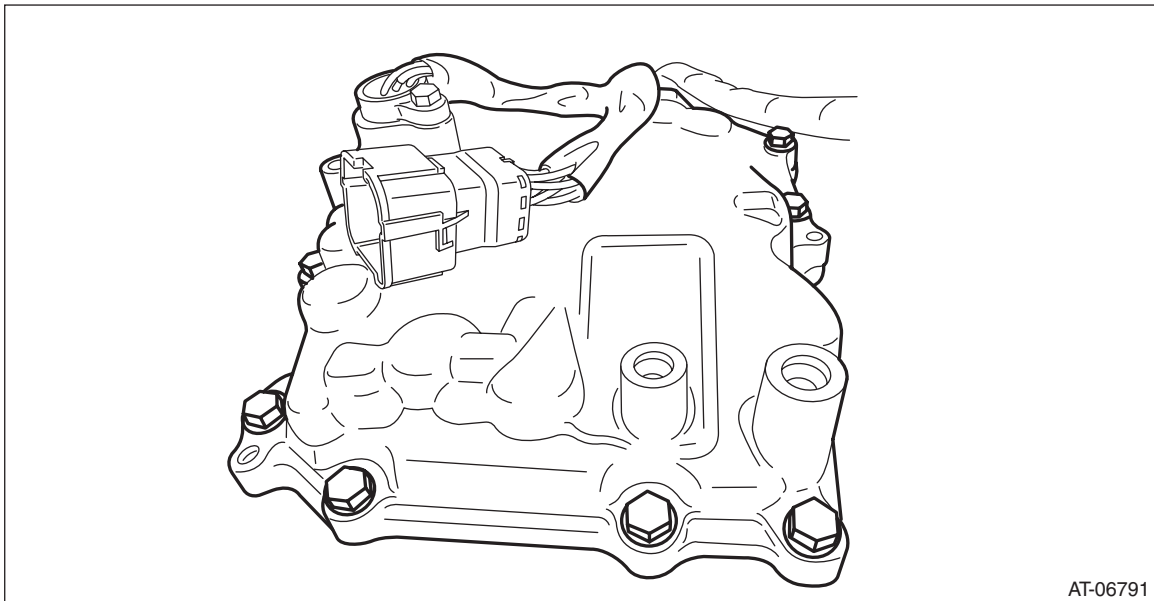

Control Valve Body

CONTINUOUSLY VARIABLE TRANSMISSION

13) Remove the transmission harness from the valve cover.

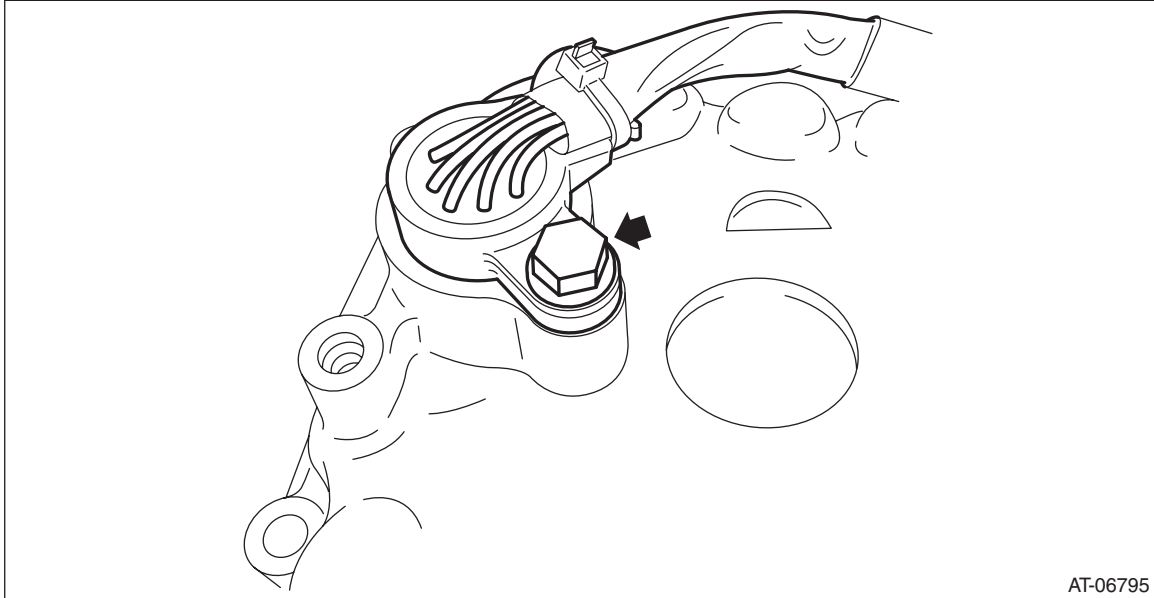

14) Remove the O-ring from the transmission harness.

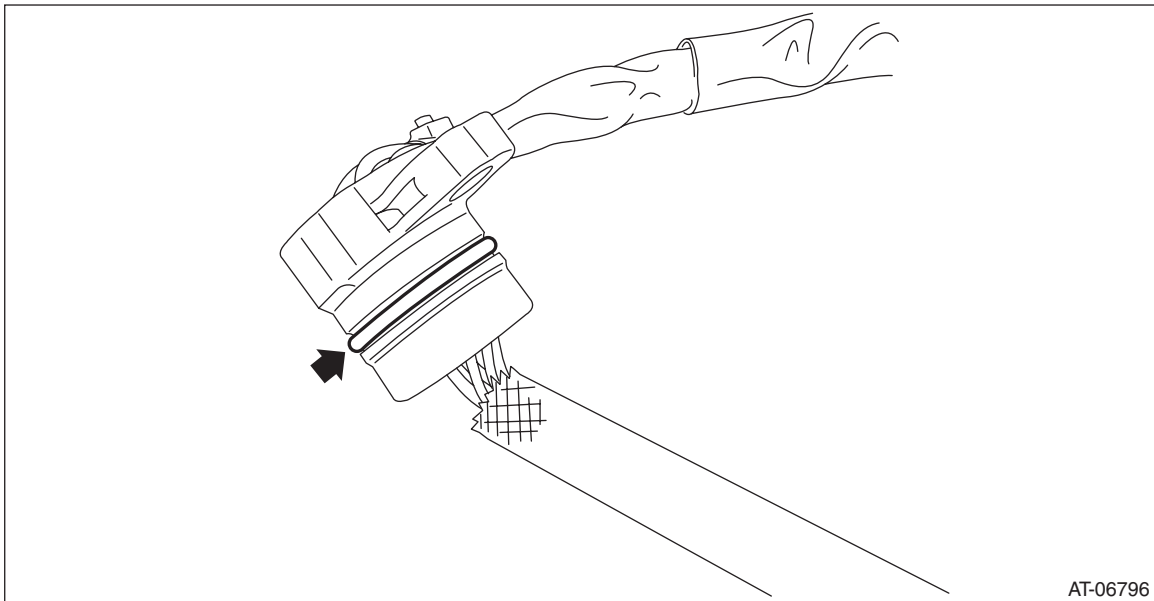

15) Disconnect the harness connector from the control valve body.

Control Valve Body

CONTINUOUSLY VARIABLE TRANSMISSION

16) Remove the control valve body.

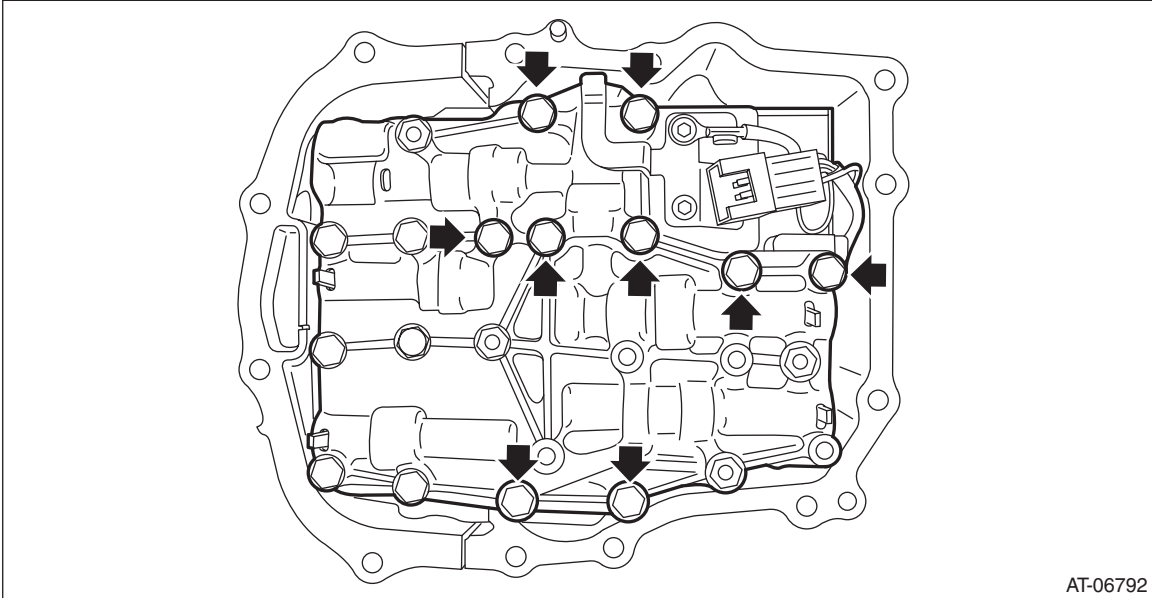

17) Remove the O-ring from the transmission.

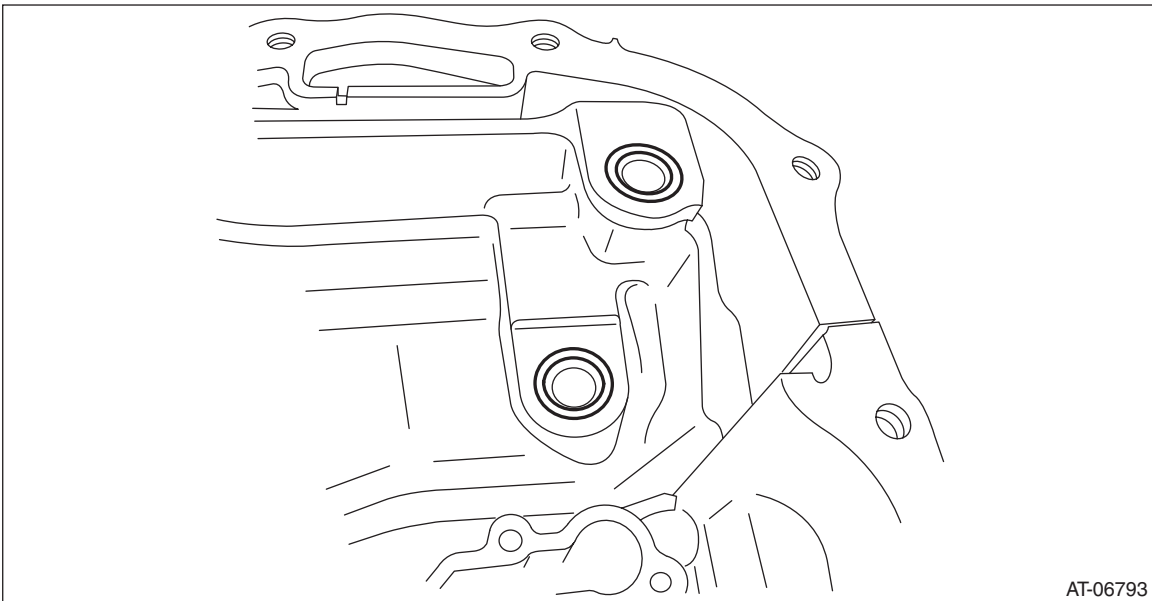

Control Valve Body

CONTINUOUSLY VARIABLE TRANSMISSION

B: INSTALLATION

1) Clean the mating surface of valve cover and transmission side.

CAUTION:

When cleaning the mating surface of the transmission side, be careful not to allow any dust, foreign matter and used liquid gasket to enter the transmission.

2) Check the control valve body for dust and other foreign matter.

3) Install the O-ring.

NOTE:

- Use new O-rings.
- Apply CVTF to the O-ring.

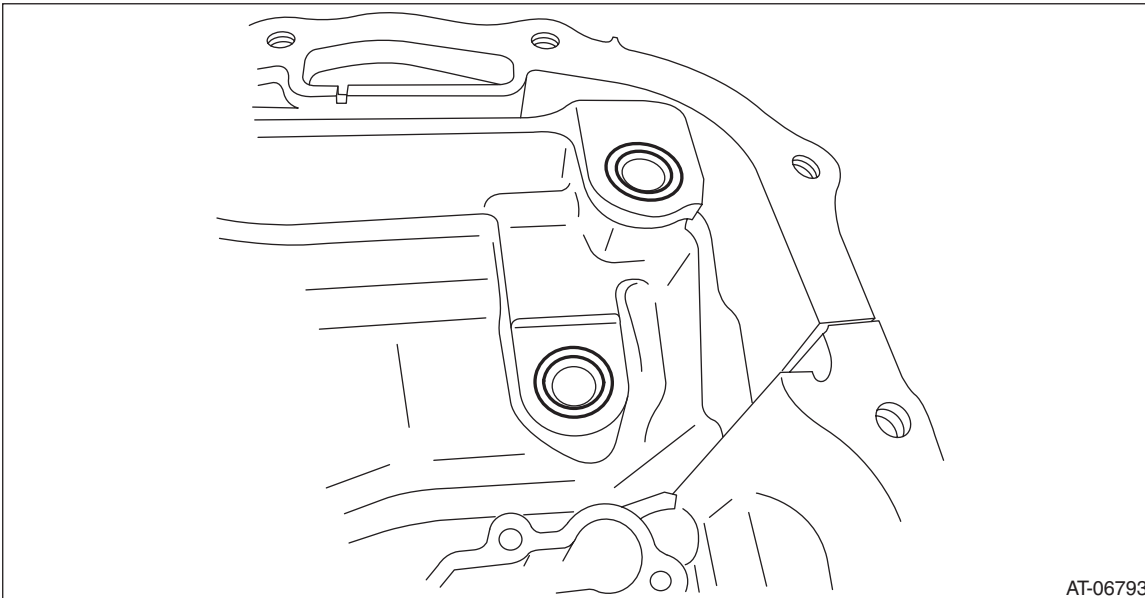

AT-06793

4) Install the control valve body.

(1) Install the control valve body to the transmission.

CAUTION:

- **Do not damage the O-ring.**
- **Perform installation so that the O-ring is not displaced.**

(2) Temporarily tighten the bolt (A: silver).

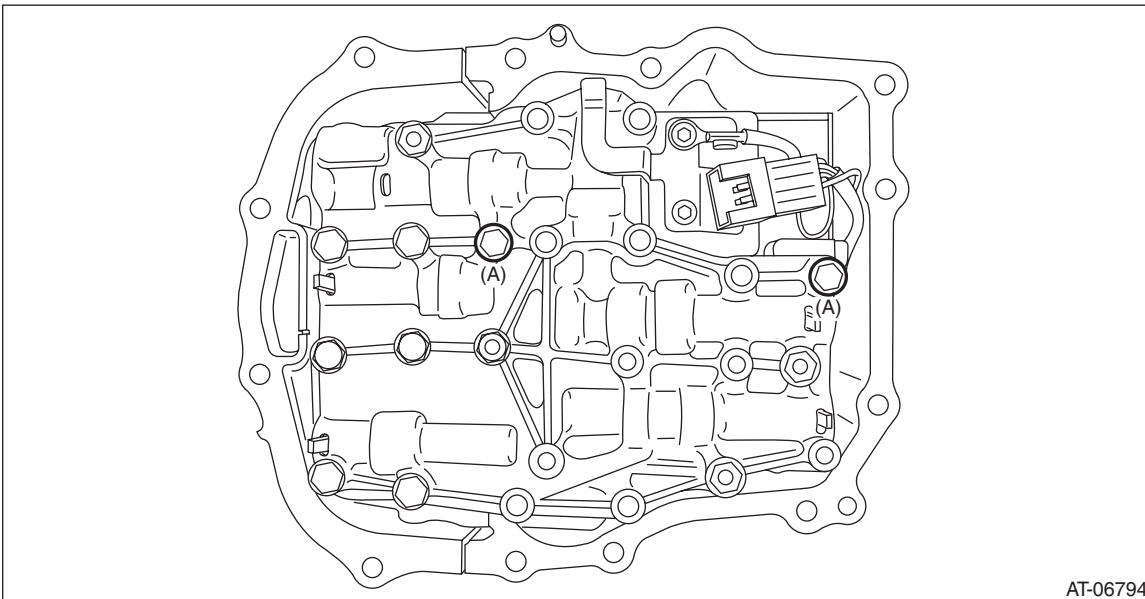

AT-06794

Control Valve Body

CONTINUOUSLY VARIABLE TRANSMISSION

(3) Attach the bolt (B).

Tightening torque:

9 N·m (0.9 kgf·m, 6.6 ft·lb)

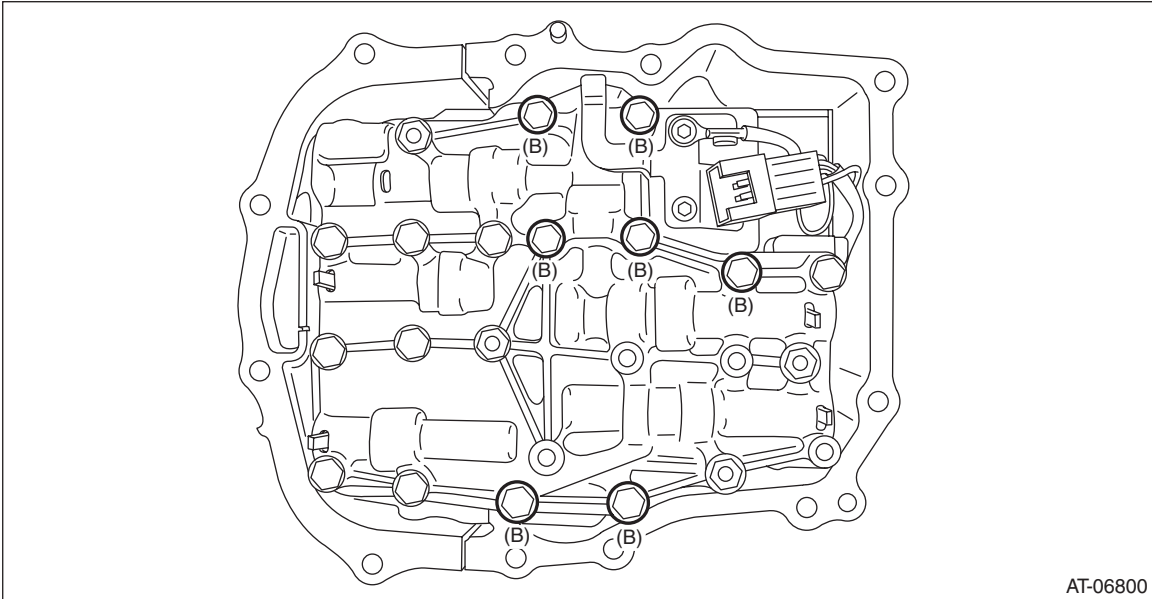

AT-06800

(4) Tighten the bolt (A: silver).

Tightening torque:

9 N·m (0.9 kgf·m, 6.6 ft·lb)

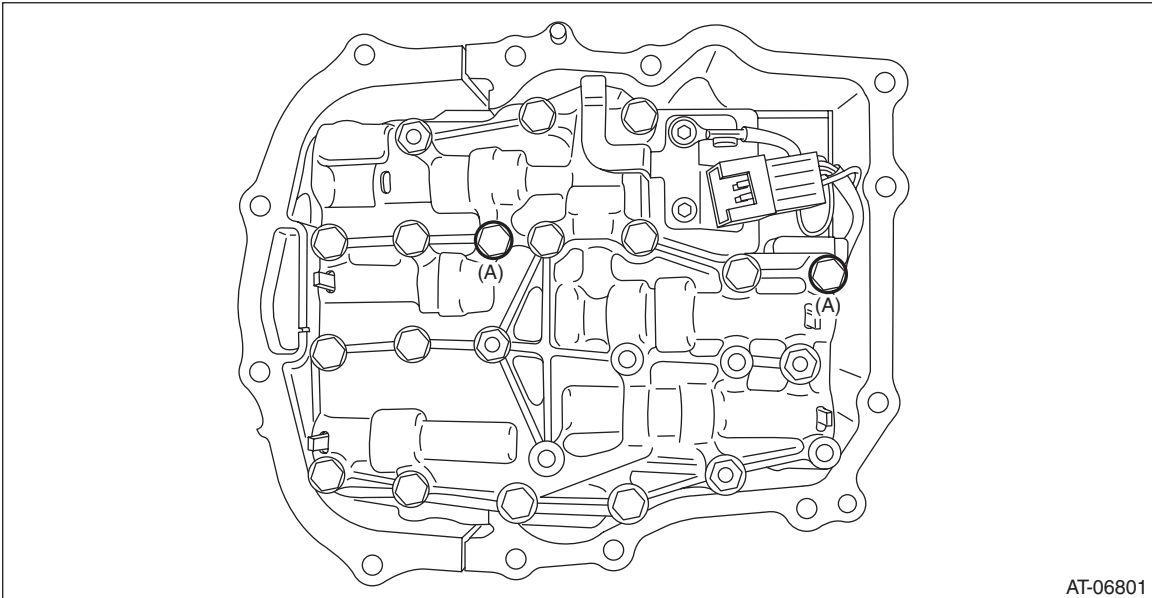

AT-06801

Control Valve Body

CONTINUOUSLY VARIABLE TRANSMISSION

5) Install the O-ring to the transmission harness.

NOTE:

- Use new O-rings.
- Apply CVTF to the O-ring.

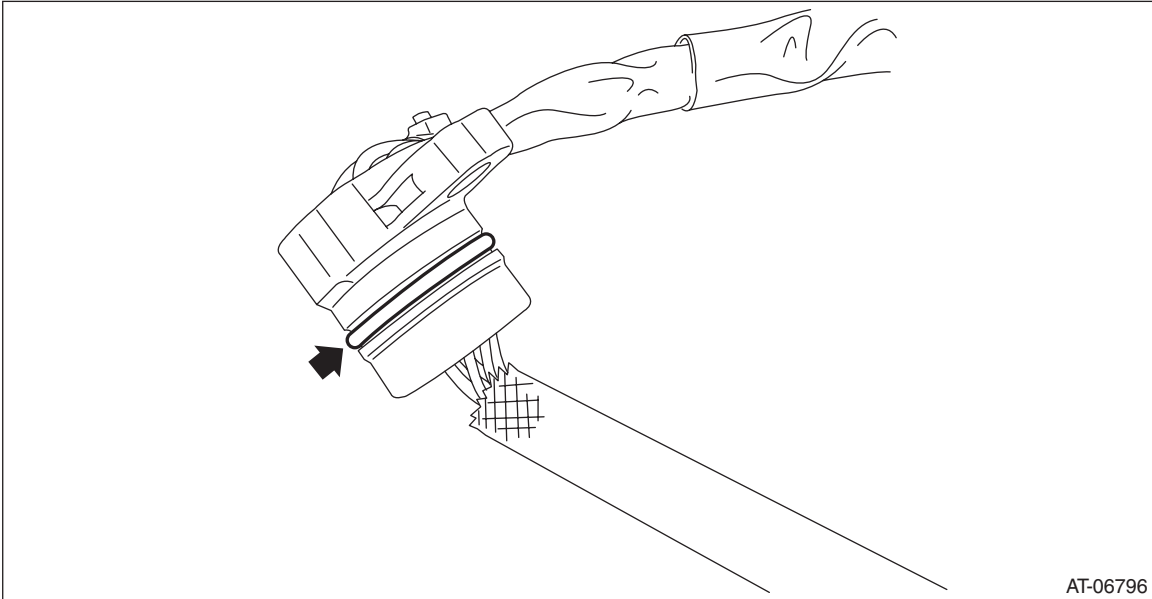

AT-06796

6) Install the transmission harness to the valve cover.

Tightening torque:

7 N·m (0.7 kgf-m, 5.2 ft-lb)

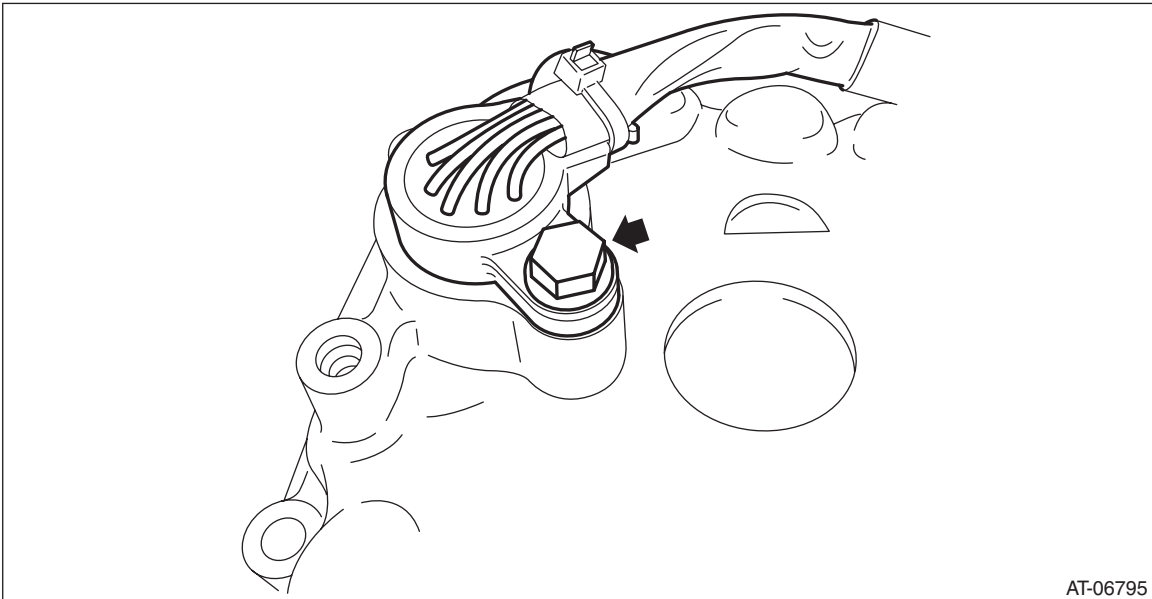

AT-06795

Control Valve Body

CONTINUOUSLY VARIABLE TRANSMISSION

7) Install the gasket to the transmission.

NOTE:

Use a new gasket.

8) Apply liquid gasket to the oval hole of gasket.

Liquid gasket:

THREE BOND 1215 (Part No. 004403007) or equivalent

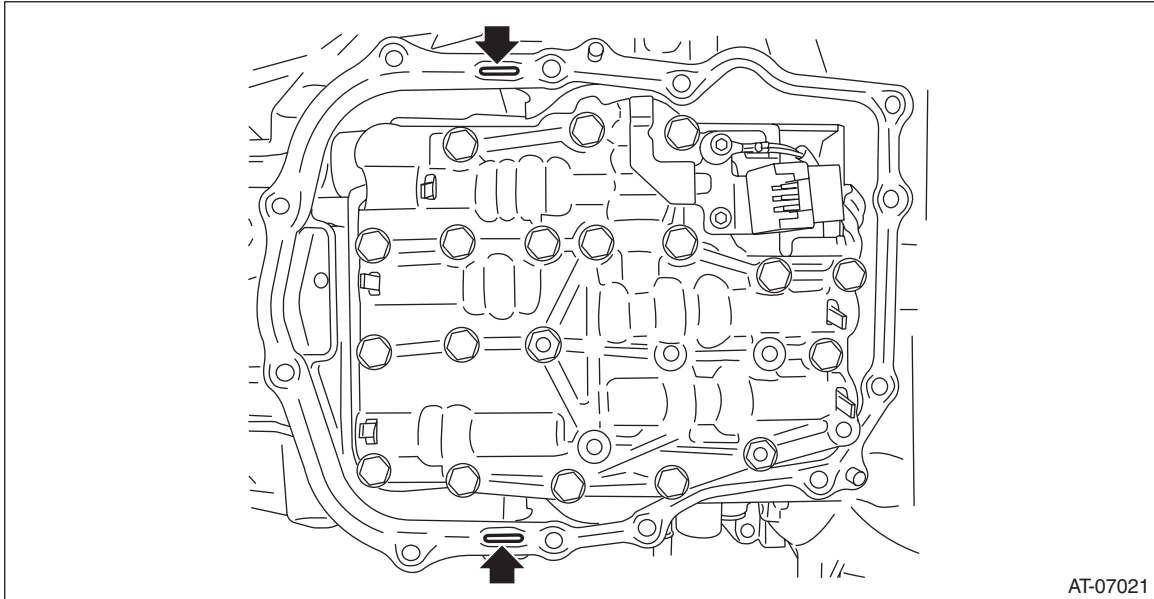

9) Connect the transmission harness connector to the control valve body, and install the valve cover.

CAUTION:

Be careful not to catch the sheet of the ST.

Tightening torque:

8 N·m (0.8 kgf·m, 5.9 ft·lb)

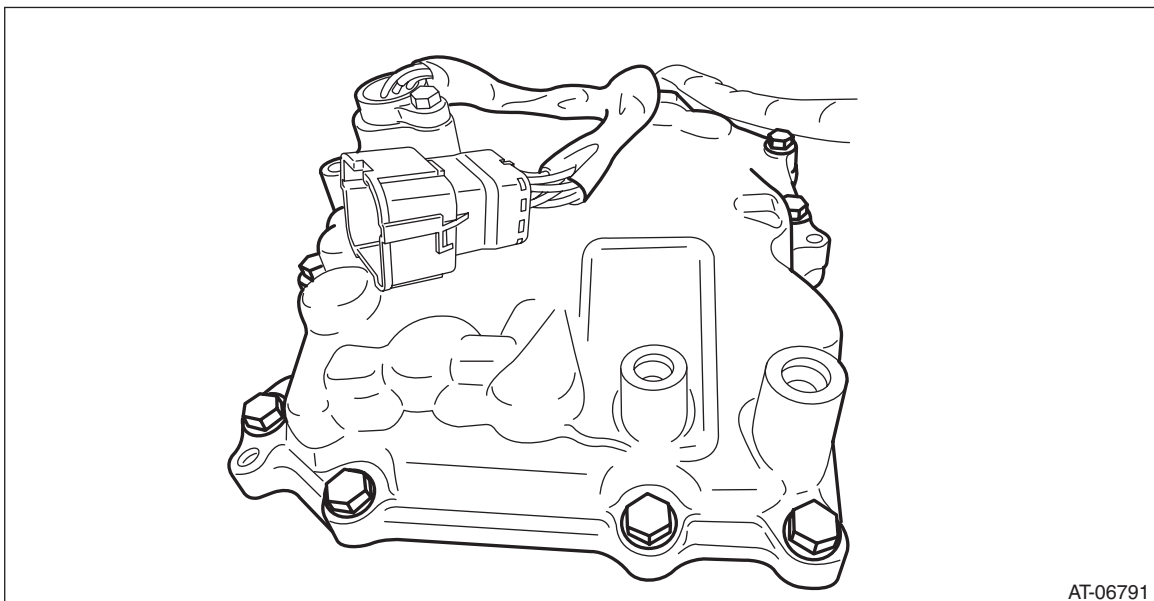

10) Remove the ST (SHEET SPECIAL TOOL).

11) Install the throttle body. <Ref. to FU(H4DO)-20, INSTALLATION, Throttle Body.>

12) Install the transmission harness connector to the harness stay.

Control Valve Body

CONTINUOUSLY VARIABLE TRANSMISSION

13) Install the transmission harness stay and transmission ground terminal.

NOTE:

Install the transmission ground terminal in the direction within the range of approx. 30° (A).

Tightening torque:

T1: 7 N·m (0.7 kgf-m, 5.2 ft-lb)

T2: 14 N·m (1.4 kgf-m, 10.3 ft-lb)

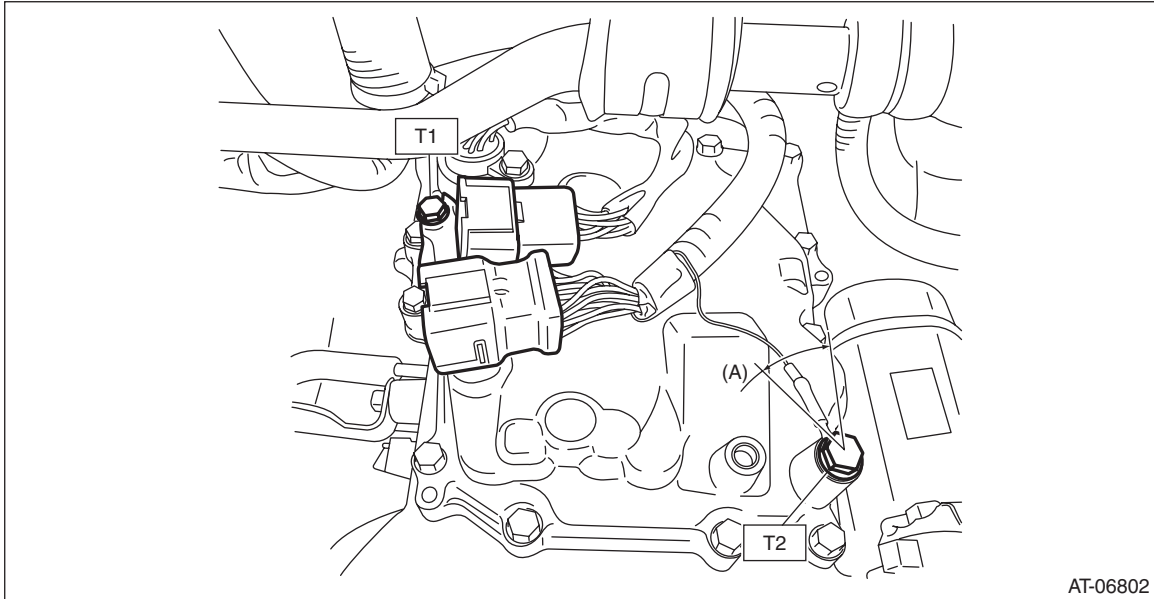

14) Install the transmission case cover.

Tightening torque:

8 N·m (0.8 kgf-m, 5.9 ft-lb)

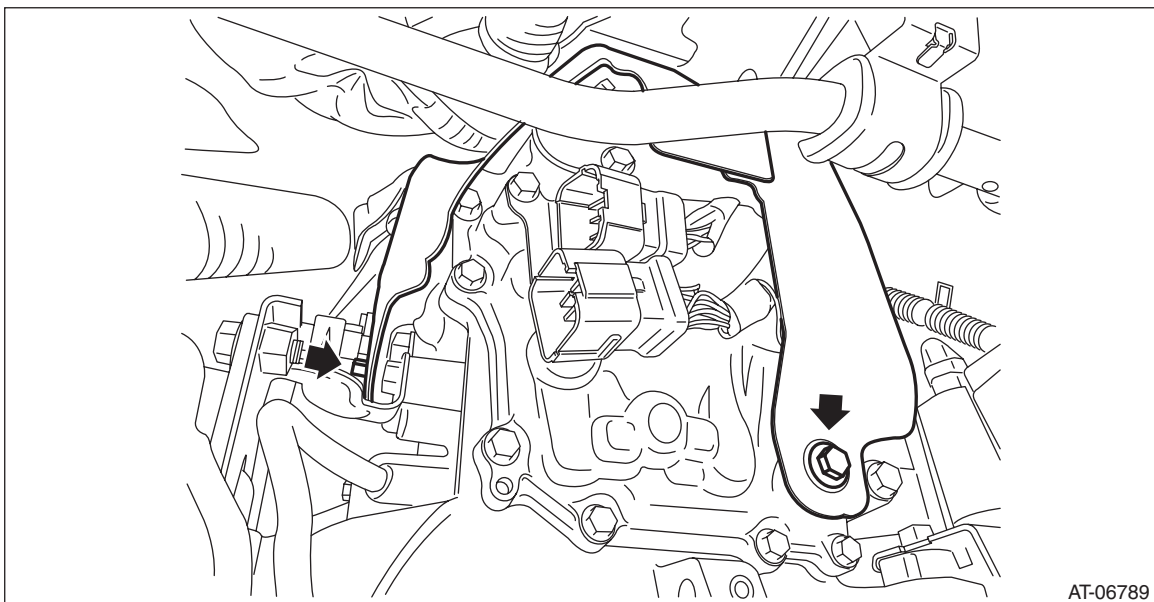

Control Valve Body

CONTINUOUSLY VARIABLE TRANSMISSION

15) Install the pitching stopper bracket and transmission radio ground cord.

Tightening torque:

41 N·m (4.2 kgf-m, 30.2 ft-lb)

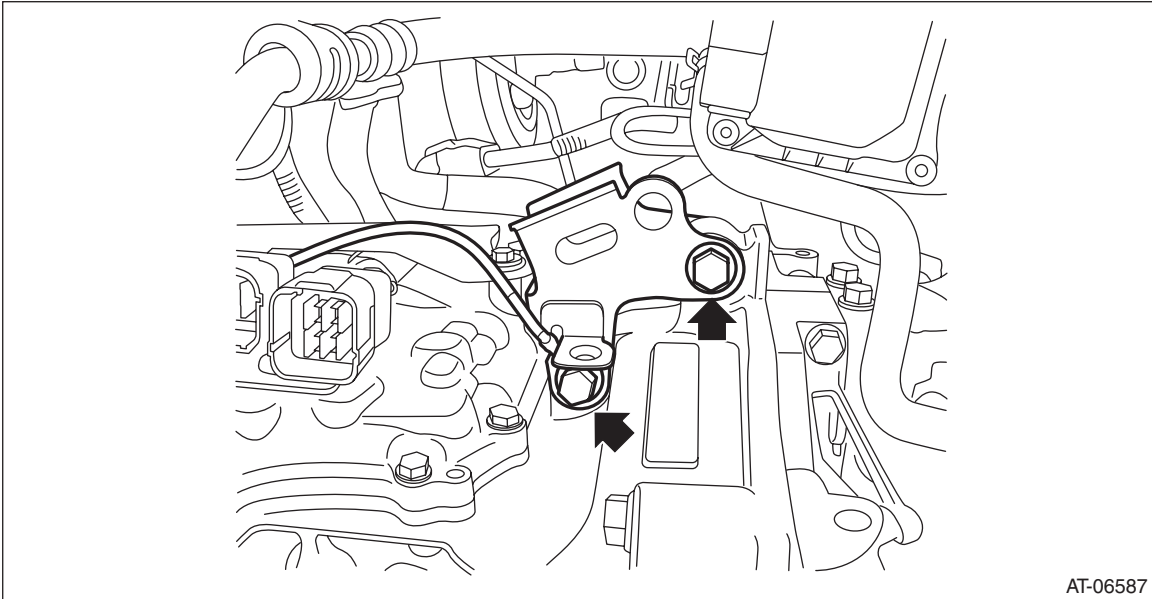

AT-06587

16) Install the air breather hose to the pitching stopper bracket.

17) Install the pitching stopper.

Tightening torque:

T1: 50 N·m (5.1 kgf-m, 36.9 ft-lb)

T2: 58 N·m (5.9 kgf-m, 42.8 ft-lb)

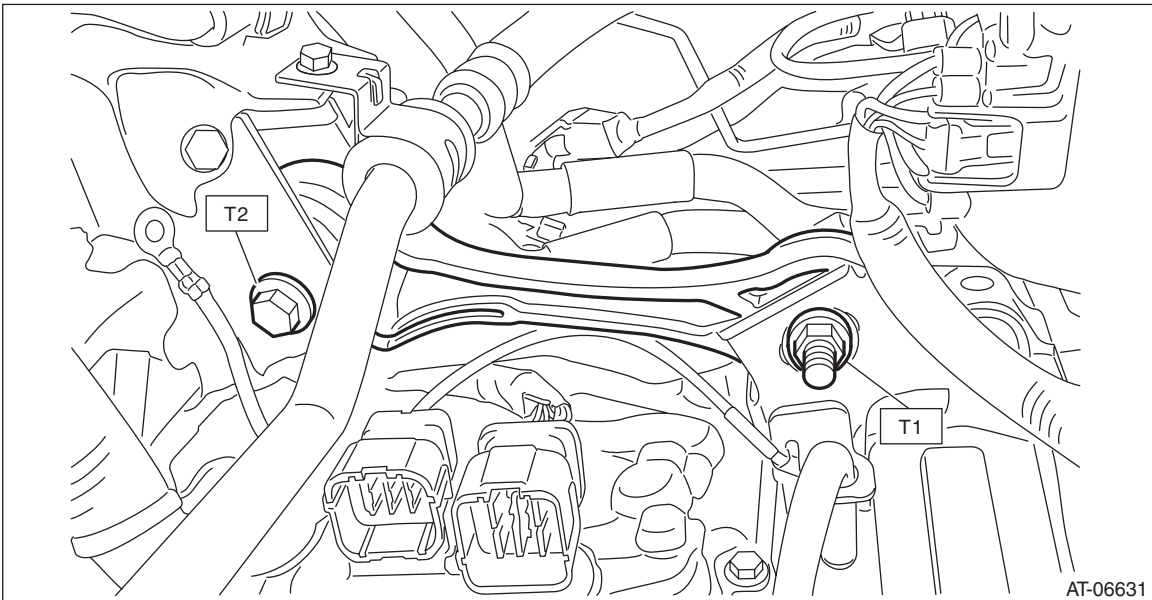

AT-06631

Control Valve Body

CONTINUOUSLY VARIABLE TRANSMISSION

18) Connect the following harness connectors.

- Transmission harness connectors
- Inhibitor harness connector
- Transmission radio ground terminal

Tightening torque:

13 N·m (1.3 kgf·m, 9.6 ft·lb)

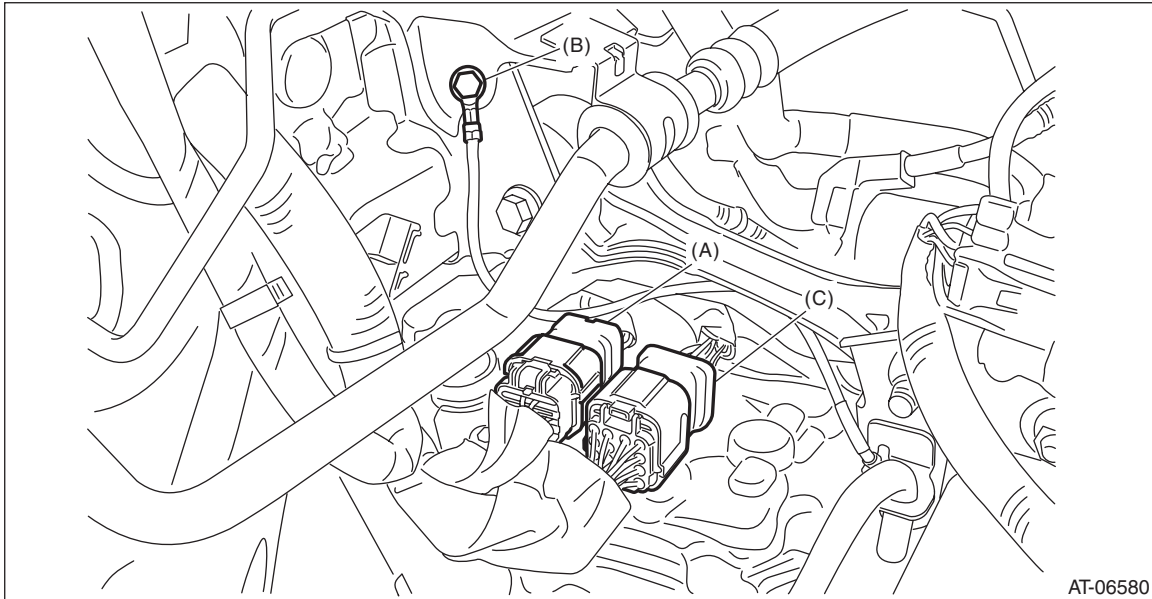

- (A) Transmission harness connectors
- (B) Transmission radio ground terminal
- (C) Inhibitor harness connector

19) Install the air intake boot assembly. <Ref. to IN(H4DO)-12, INSTALLATION, Air Intake Boot.>

20) Adjust the CVTF level. <Ref. to CVT-34, ADJUSTMENT, CVTF.>

Control Valve Body

CONTINUOUSLY VARIABLE TRANSMISSION

C: INSPECTION

- Check each part for damage or dust.
- Measure the resistance of each solenoid, sensor and ground wire.

NOTE:

Measurement should be performed at a temperature of 20°C (68°F).

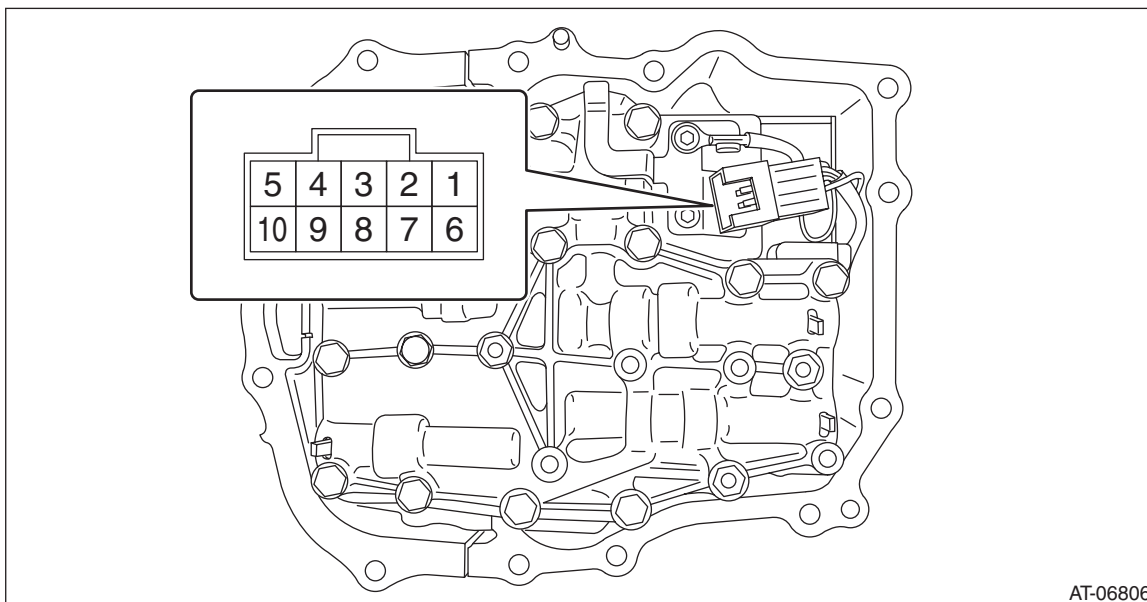

• Solenoid

Solenoid	Terminal No.	Standard
Primary UP solenoid	No. 2 — Control valve body	Approx. 10 — 13.5 Ω
Secondary solenoid	No. 3 — Control valve body	Approx. 5 — 7 Ω
F&R clutch solenoid	No. 4 — Control valve body	Approx. 4 — 6 Ω
Primary DOWN solenoid	No. 7 — Control valve body	Approx. 10 — 13.5 Ω
Lock-up duty solenoid	No. 9 — Control valve body	Approx. 10 — 13.5 Ω
AWD solenoid	No. 10 — Control valve body	Approx. 2 — 4.5 Ω

• Oil temperature sensor

Sensor	Terminal No.	Standard (at 20°C (68°F))
Oil temperature sensor	No. 1 — No. 6	Approx. 2.5 k Ω

• Transmission ground

Terminal No.	Standard
No. 8 — Control valve body	Less than 1 Ω