

# Transmission Harness

CONTINUOUSLY VARIABLE TRANSMISSION

## 21. Transmission Harness

### A: REMOVAL

#### 1. INHIBITOR HARNESS

- 1) Remove the transmission from the vehicle. <Ref. to CVT-56, REMOVAL, Automatic Transmission Assembly.>
- 2) Remove the transmission case cover.

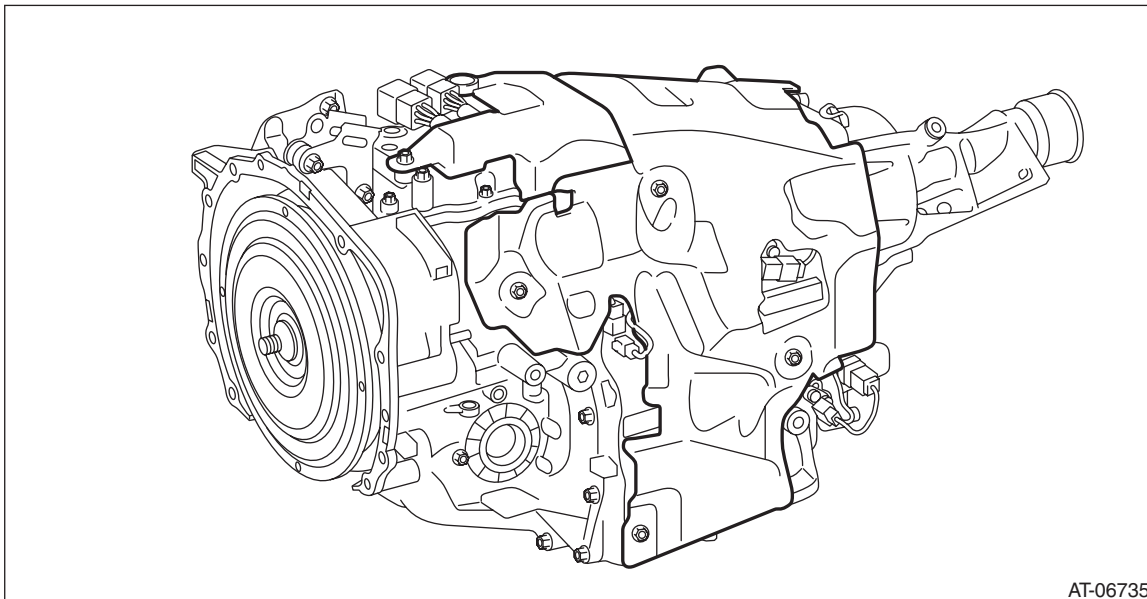

AT-06735

- 3) Remove the harness connector from the ground terminal, turbine speed sensor, primary speed sensor, secondary speed sensor and secondary pressure sensor.

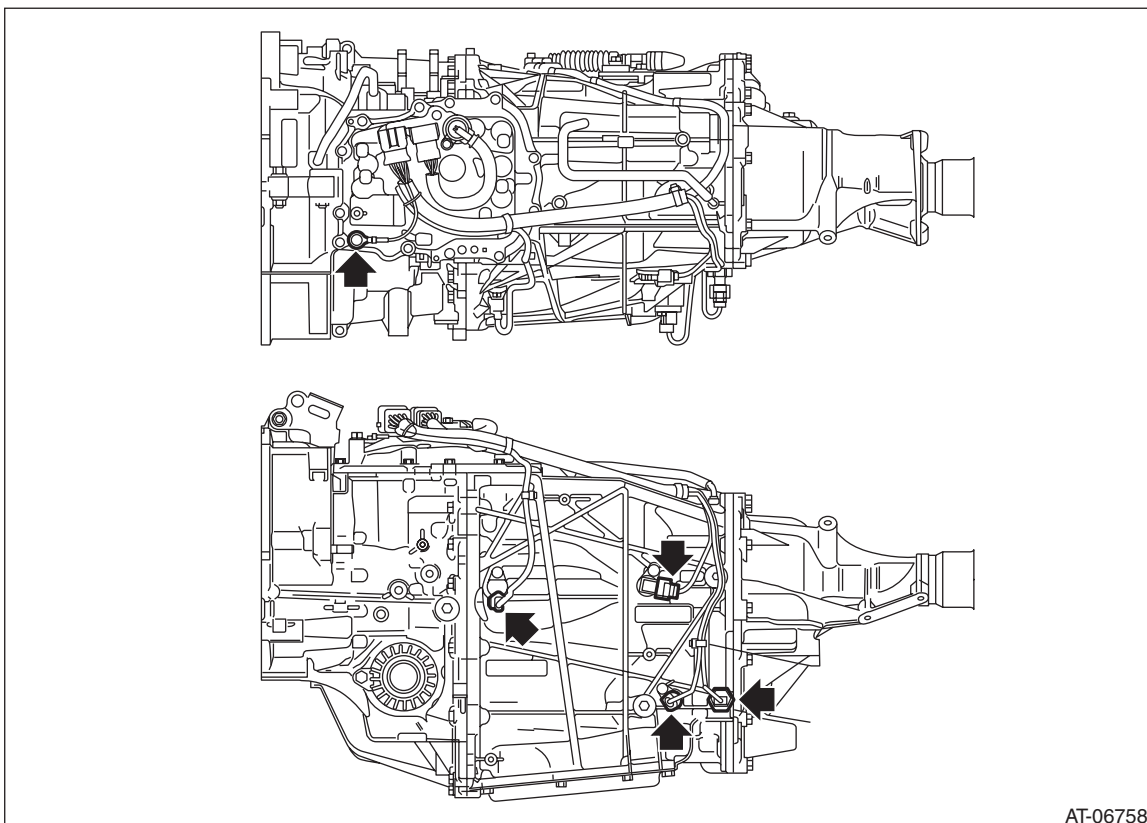

AT-06758

# Transmission Harness

CONTINUOUSLY VARIABLE TRANSMISSION

- 4) Remove the harness connector from inhibitor switch.

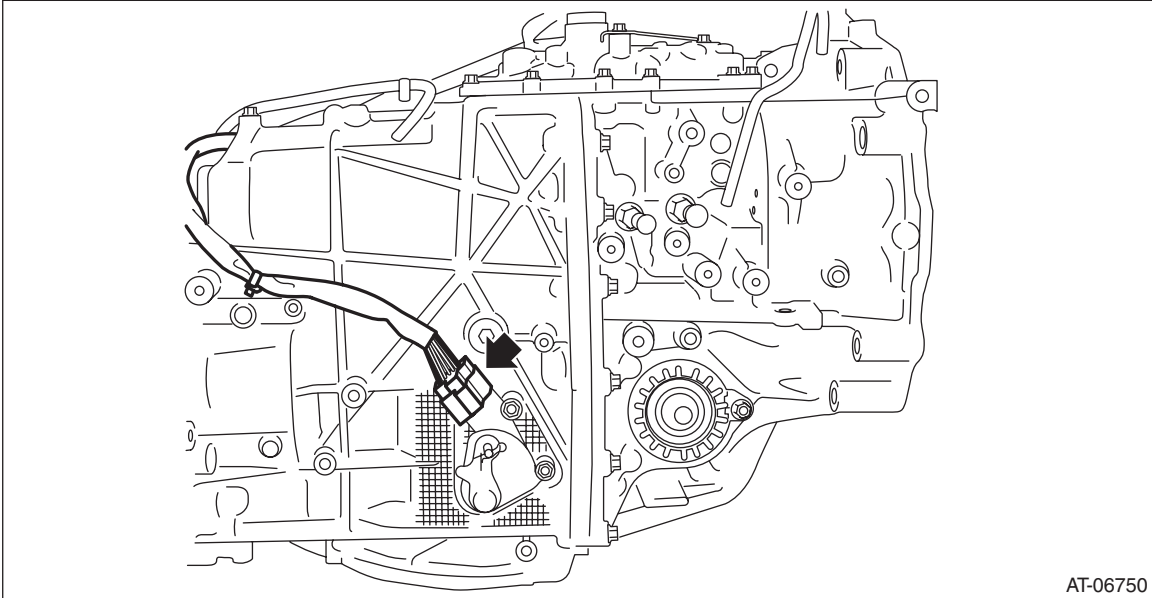

AT-06750

- 5) Remove the inhibitor harness connector from the transmission harness stay.

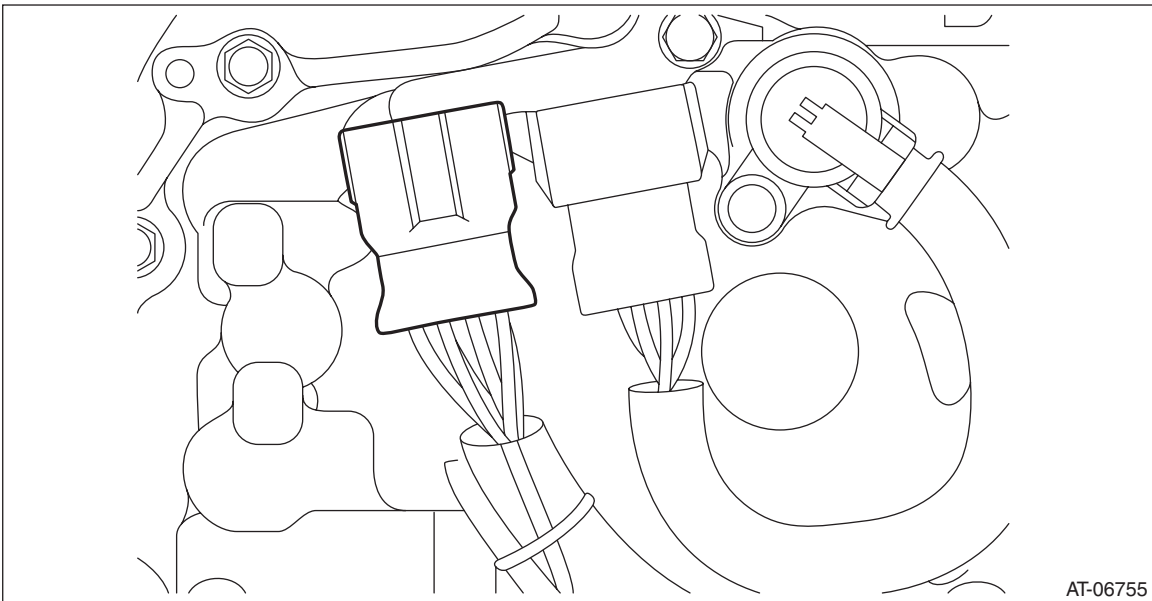

AT-06755

- 6) Remove the harness clip from the transmission, and remove the inhibitor harness.

# Transmission Harness

CONTINUOUSLY VARIABLE TRANSMISSION

## 2. TRANSMISSION HARNESS

- 1) Disconnect the ground cable from battery.
- 2) Remove the air intake boot assembly. <Ref. to IN(H4DO)-12, REMOVAL, Air Intake Boot.>
- 3) Disconnect the following connectors.
  - Transmission harness connectors
  - Inhibitor harness connector
  - Transmission radio ground terminal

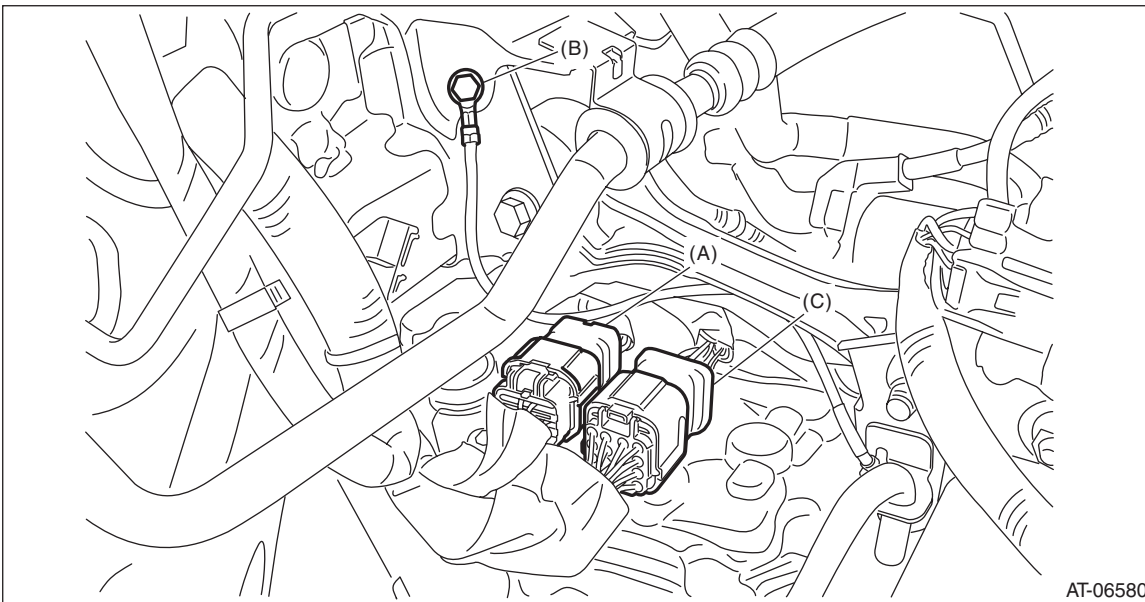

- (A) Transmission harness connectors
- (B) Transmission radio ground terminal
- (C) Inhibitor harness connector

- 4) Remove the pitching stopper.

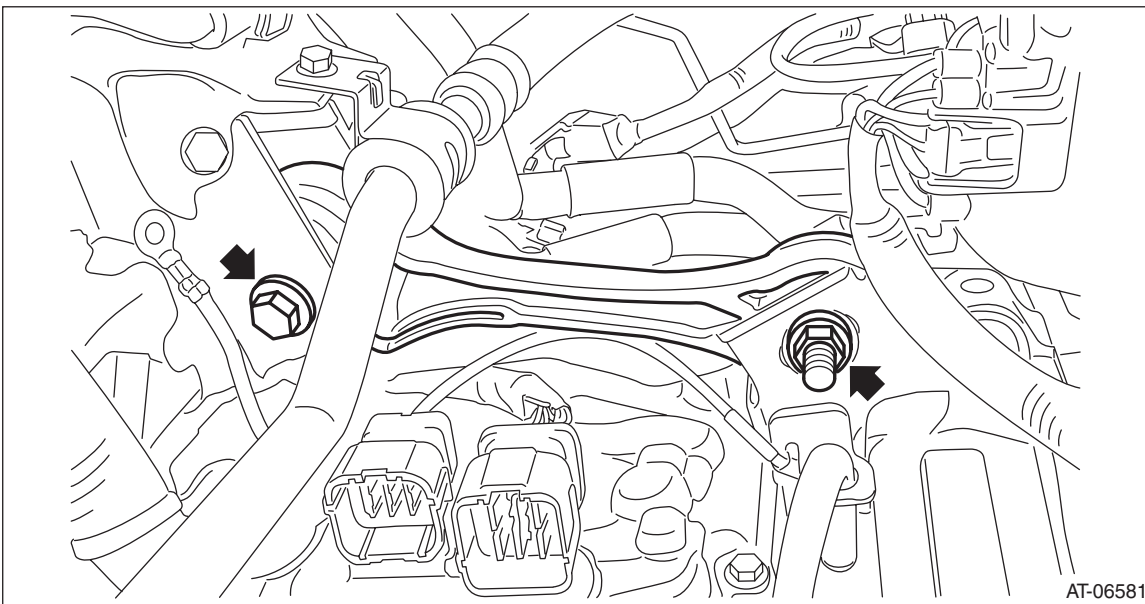

# Transmission Harness

CONTINUOUSLY VARIABLE TRANSMISSION

5) Remove the air breather hose from the pitching stopper bracket, and then remove the pitching stopper bracket and transmission radio ground cord.

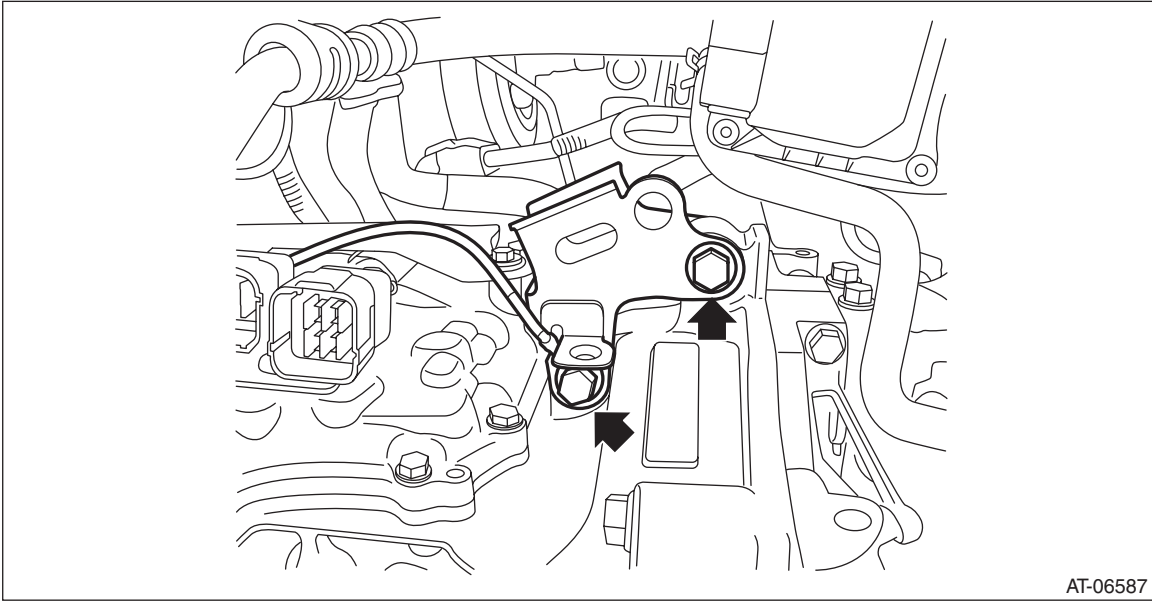

6) Remove the transmission case cover.

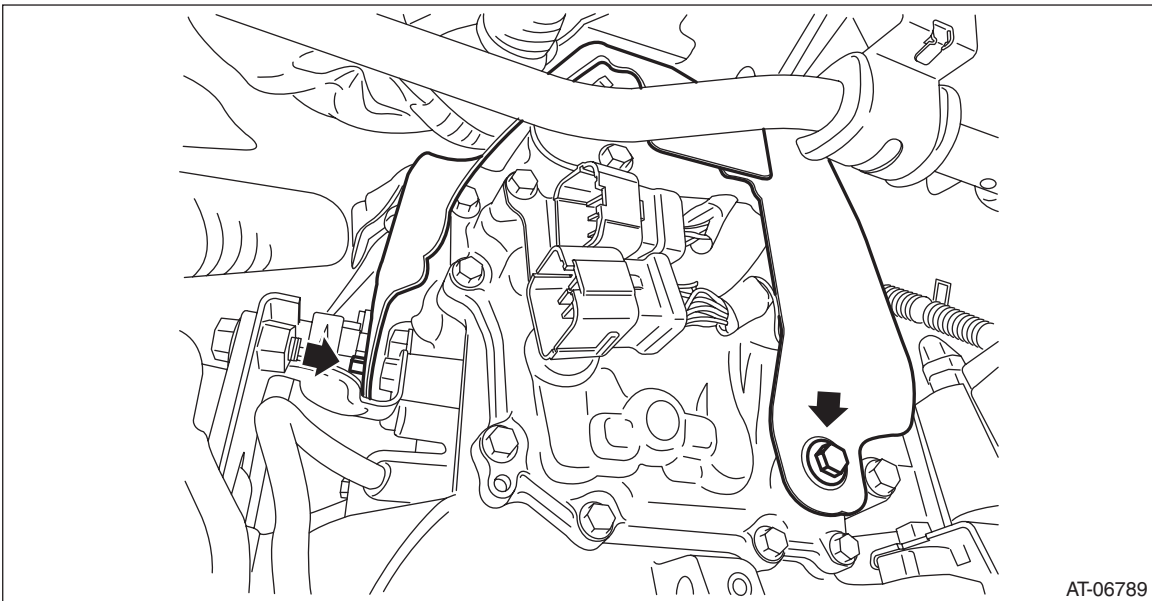

# Transmission Harness

## CONTINUOUSLY VARIABLE TRANSMISSION

7) Remove the transmission harness stay and ground terminal.

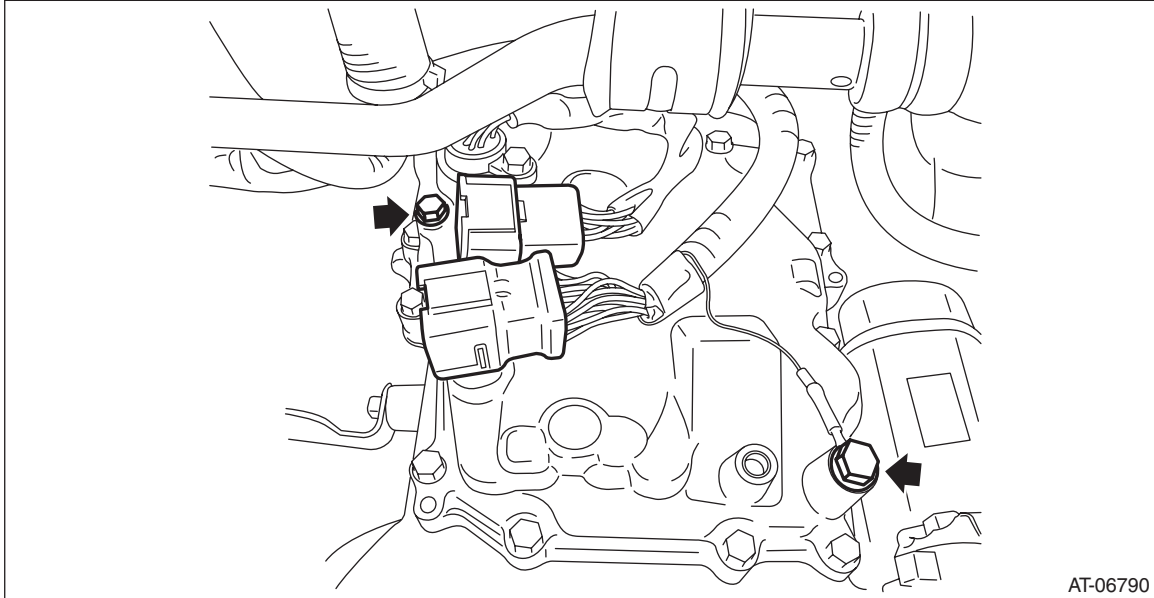

8) Remove the transmission harness connector from the harness stay.

9) Clean the transmission exterior.

10) Set the ST on the vehicle.

ST 18761AA010 SHEET SPECIAL TOOL

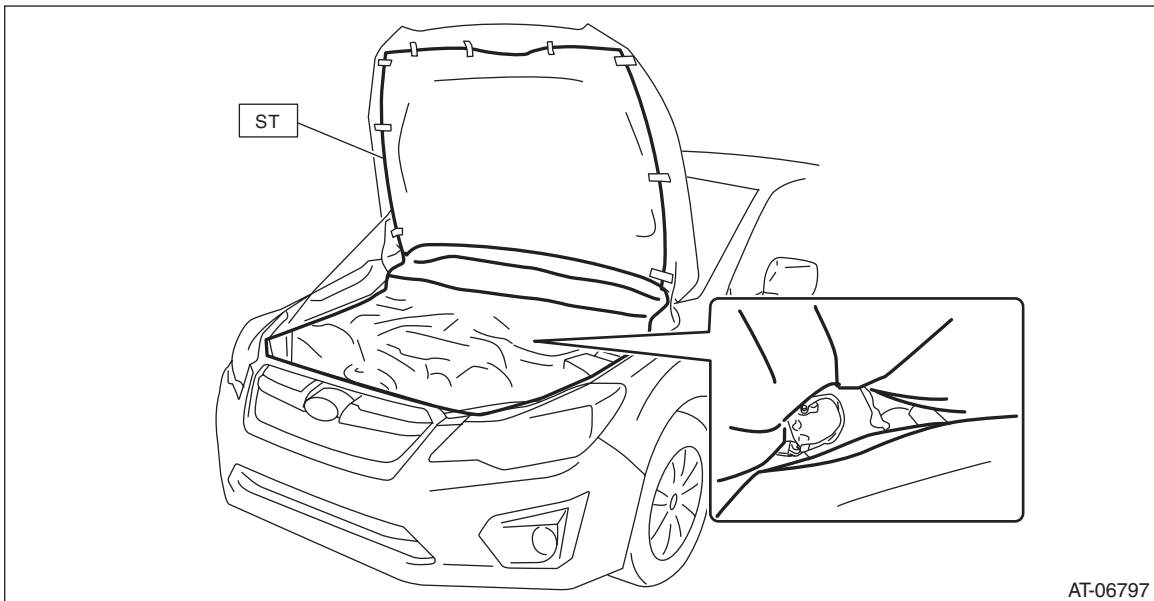

# Transmission Harness

CONTINUOUSLY VARIABLE TRANSMISSION

11) Remove the valve cover and gasket.

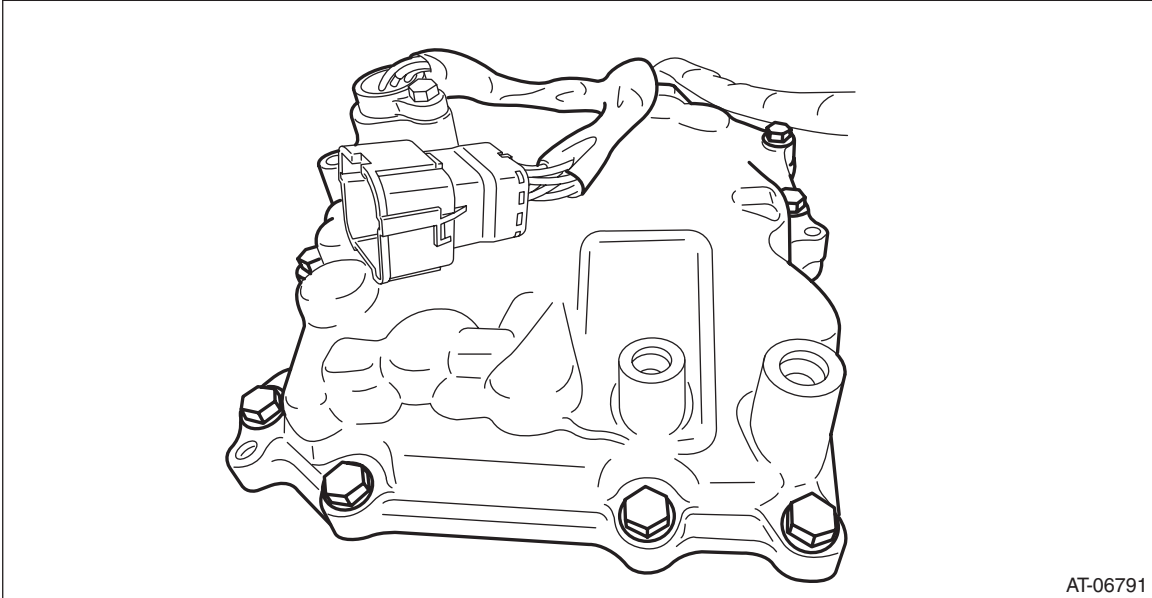

12) Remove the transmission harness connector from the control valve body.  
13) Remove the transmission harness from the valve cover.

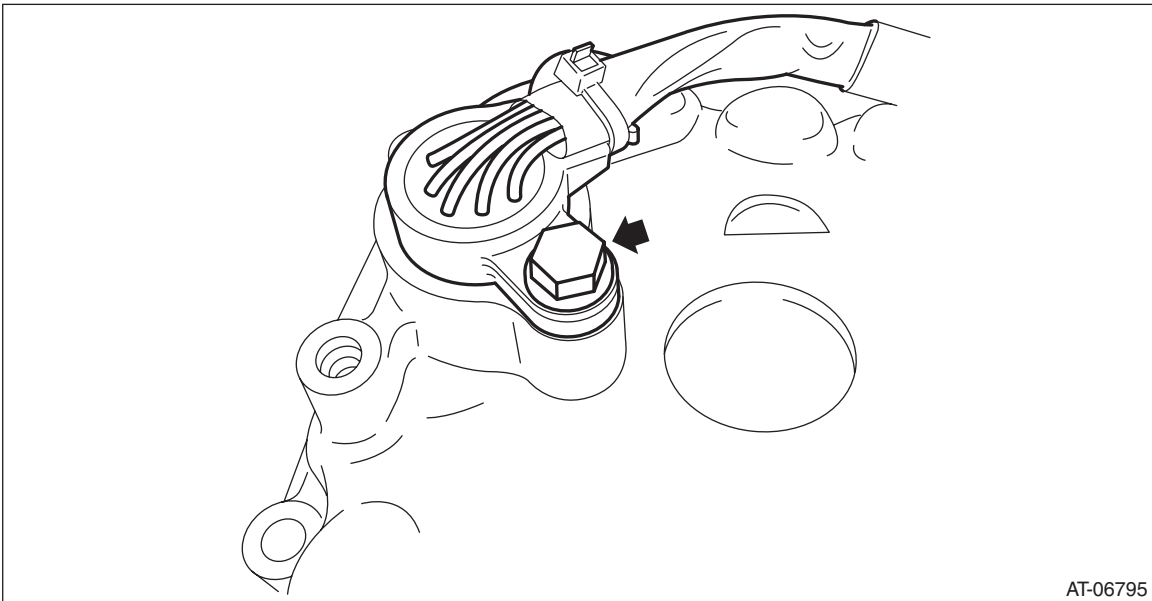

# Transmission Harness

CONTINUOUSLY VARIABLE TRANSMISSION

14) Remove the O-ring from the transmission harness.

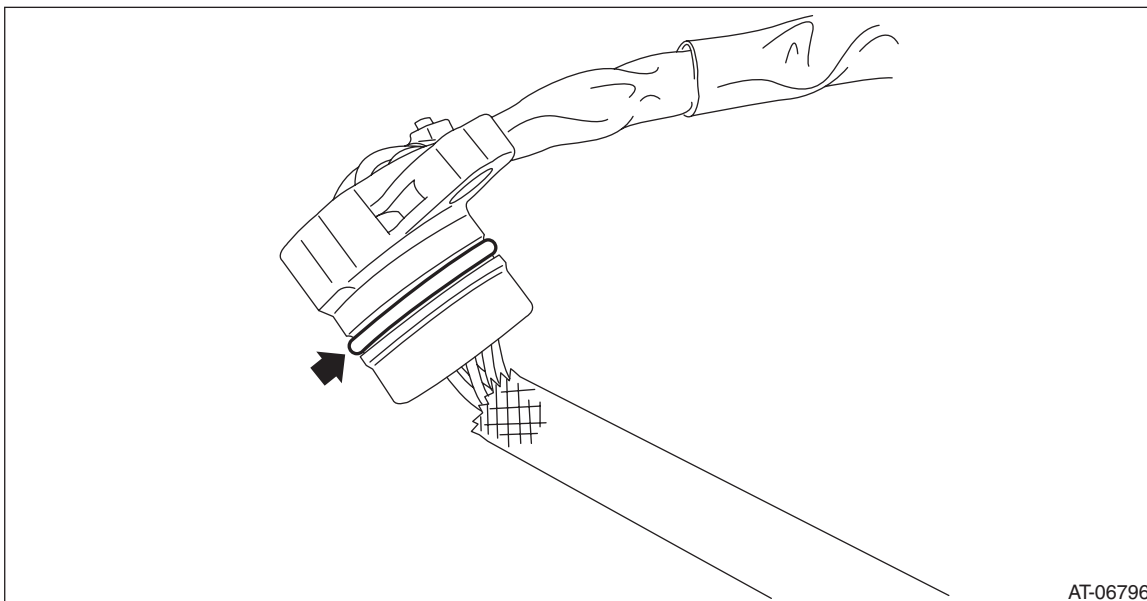

AT-06796

## B: INSTALLATION

### 1. INHIBITOR HARNESS

Install in the reverse order of removal.

NOTE:

Install the transmission ground terminal in the direction within the range of approx. 30° (A).

**Tightening torque:**

**T1: 7 N·m (0.7 kgf-m, 3.7 ft-lb)**

**T2: 14 N·m (1.4 kgf-m, 10.3 ft-lb)**

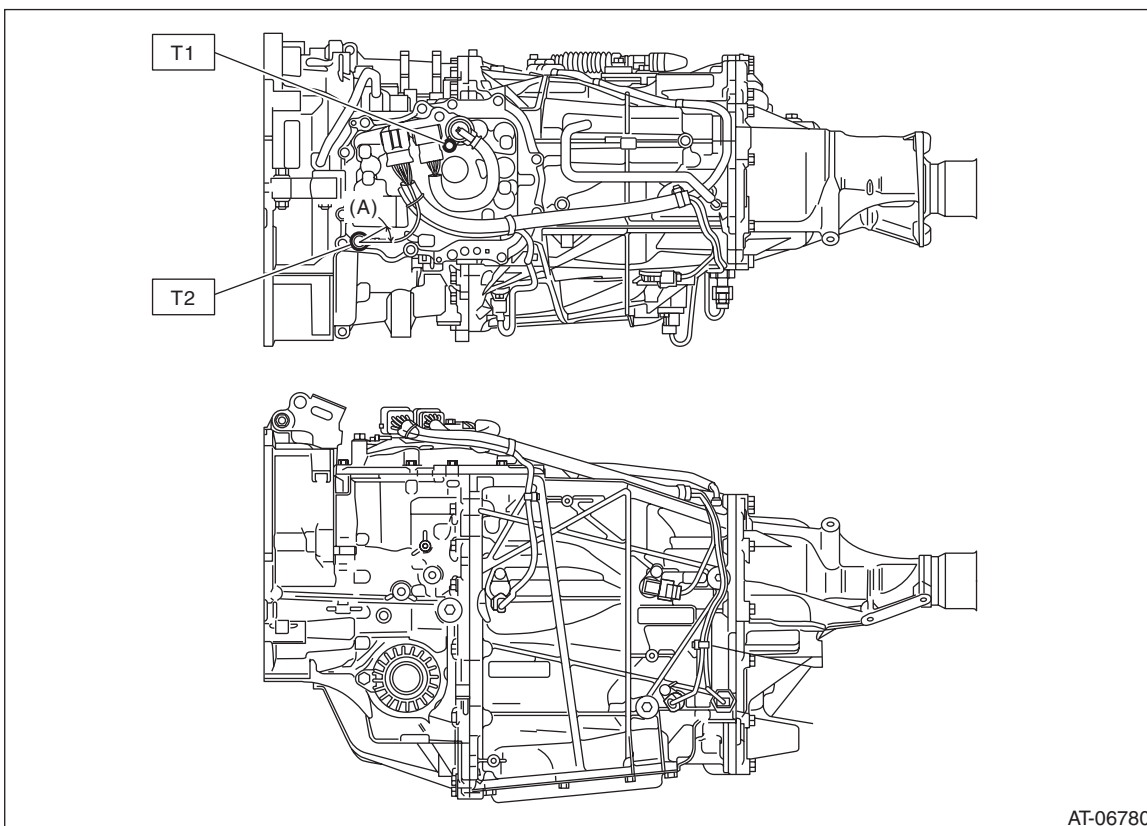

AT-06780

CVT-130

# Transmission Harness

CONTINUOUSLY VARIABLE TRANSMISSION

## 2. TRANSMISSION HARNESS

1) Clean the mating surface of valve cover and transmission side.

### CAUTION:

**When cleaning the mating surface of the transmission side, be careful not to allow any dust, foreign matter and used liquid gasket to enter the transmission.**

2) Check the control valve body for dust and other foreign matter.

3) Install the O-ring to the transmission harness.

### NOTE:

- Use new O-rings.
- Apply CVTF to the O-ring.

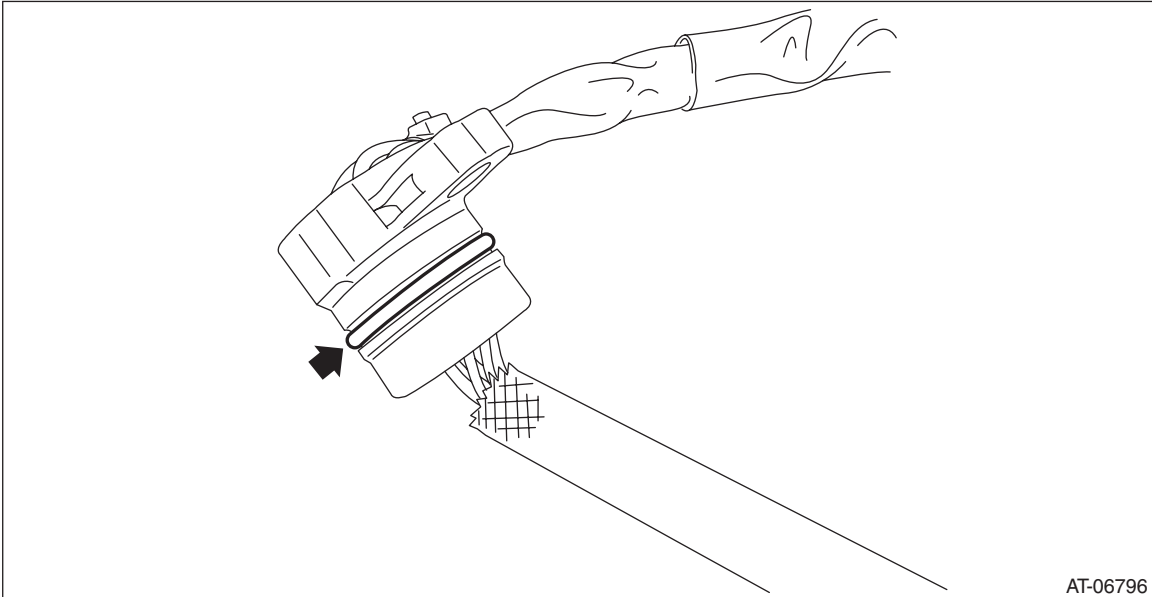

4) Install the transmission harness to the valve cover.

### Tightening torque:

**7 N·m (0.7 kgf-m, 5.2 ft-lb)**

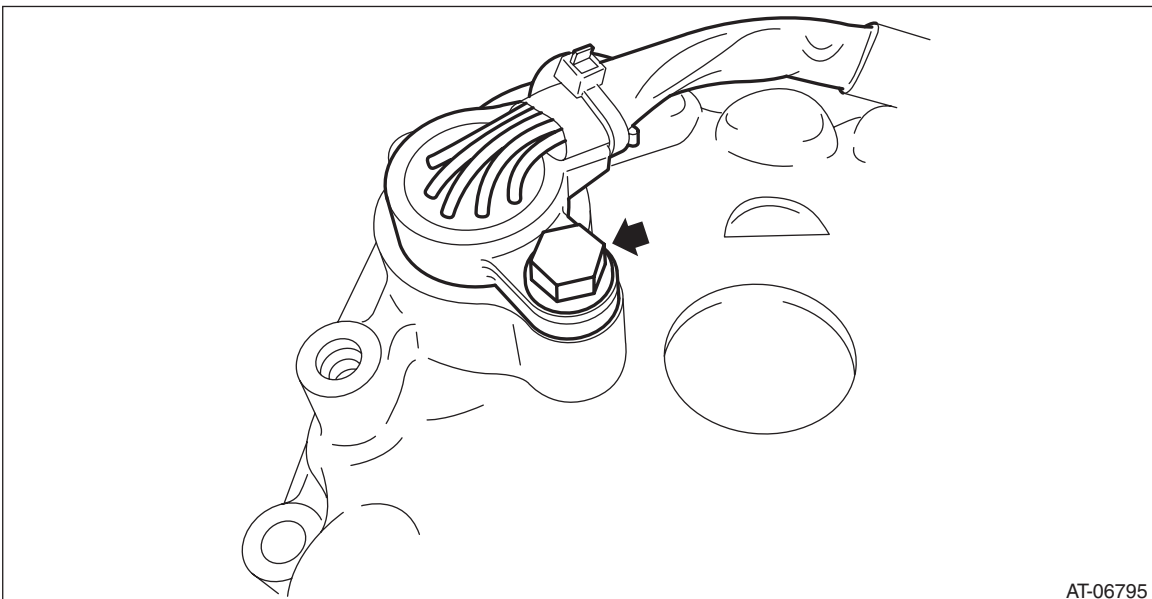

5) Install the gasket to the transmission.

### NOTE:

Use a new gasket.



## Transmission Harness

### CONTINUOUSLY VARIABLE TRANSMISSION

6) Apply liquid gasket to the oval hole of gasket.

**Liquid gasket:**

**THREE BOND 1215 (Part No. 004403007) or equivalent**

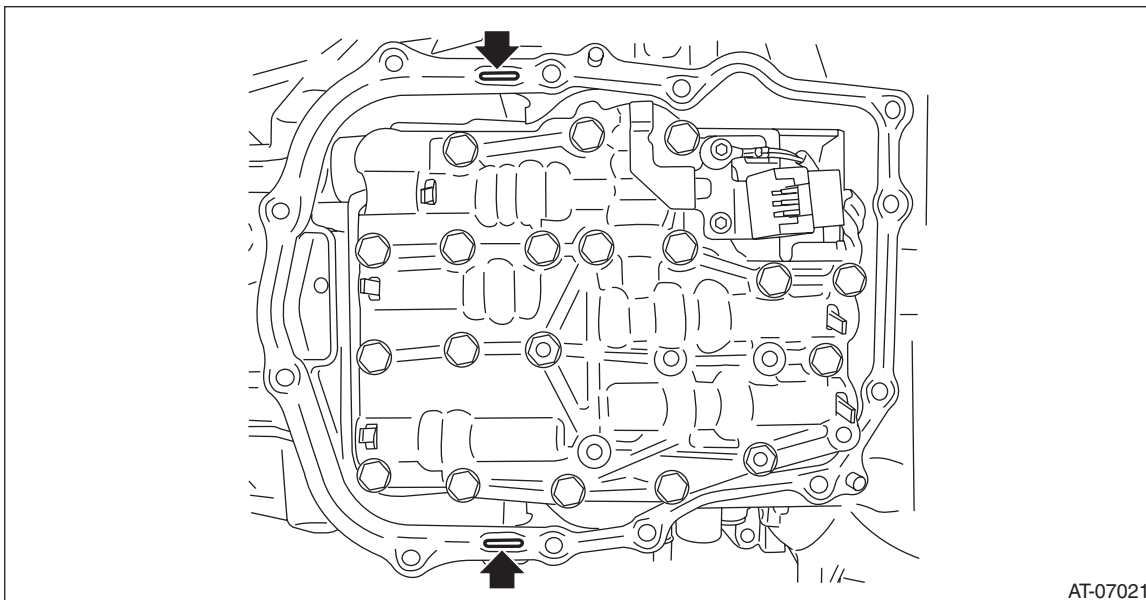

7) Connect the transmission harness connector to the control valve body, and install the valve cover.

**CAUTION:**

**Be careful not to catch the sheet of the ST.**

**Tightening torque:**

**8 N·m (0.8 kgf-m, 5.9 ft-lb)**

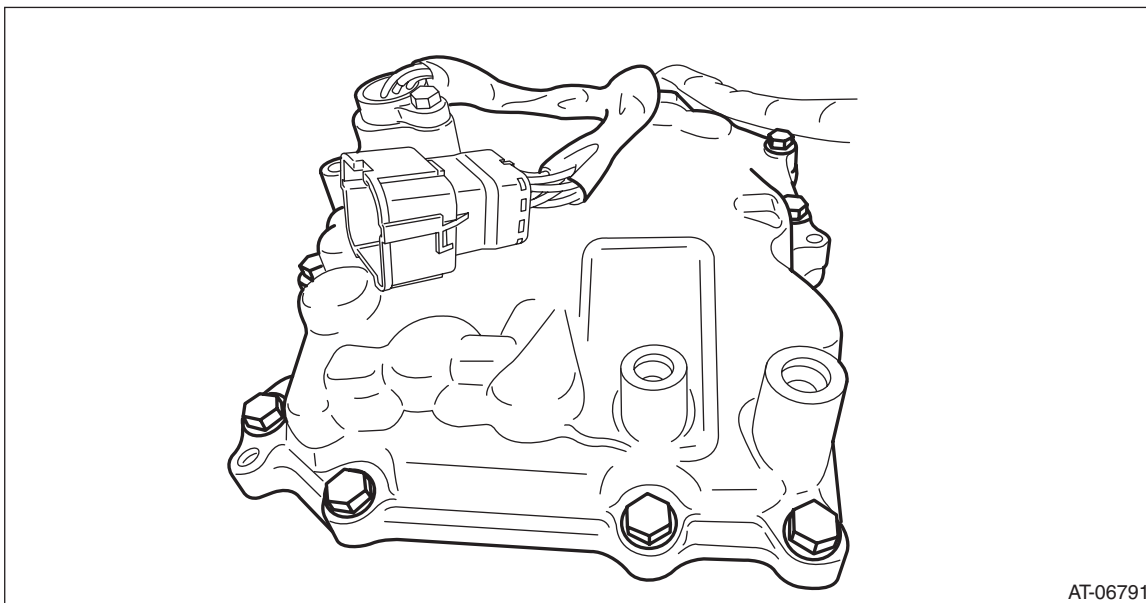

8) Remove the ST (SHEET SPECIAL TOOL).

9) Install the transmission harness connector to the harness stay.

# Transmission Harness

CONTINUOUSLY VARIABLE TRANSMISSION

10) Install the transmission harness stay and transmission ground terminal.

NOTE:

Install the transmission ground terminal in the direction within the range of approx. 30° (A).

**Tightening torque:**

**T1: 7 N·m (0.7 kgf-m, 5.2 ft-lb)**

**T2: 14 N·m (1.4 kgf-m, 10.3 ft-lb)**

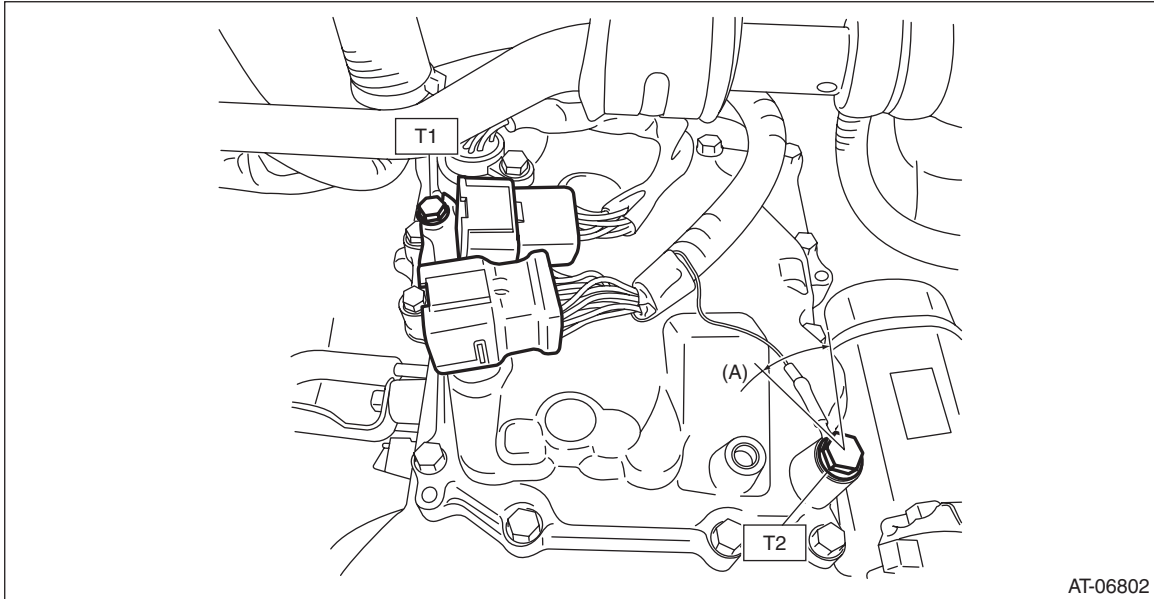

11) Install the transmission case cover.

**Tightening torque:**

**8 N·m (0.8 kgf-m, 5.9 ft-lb)**

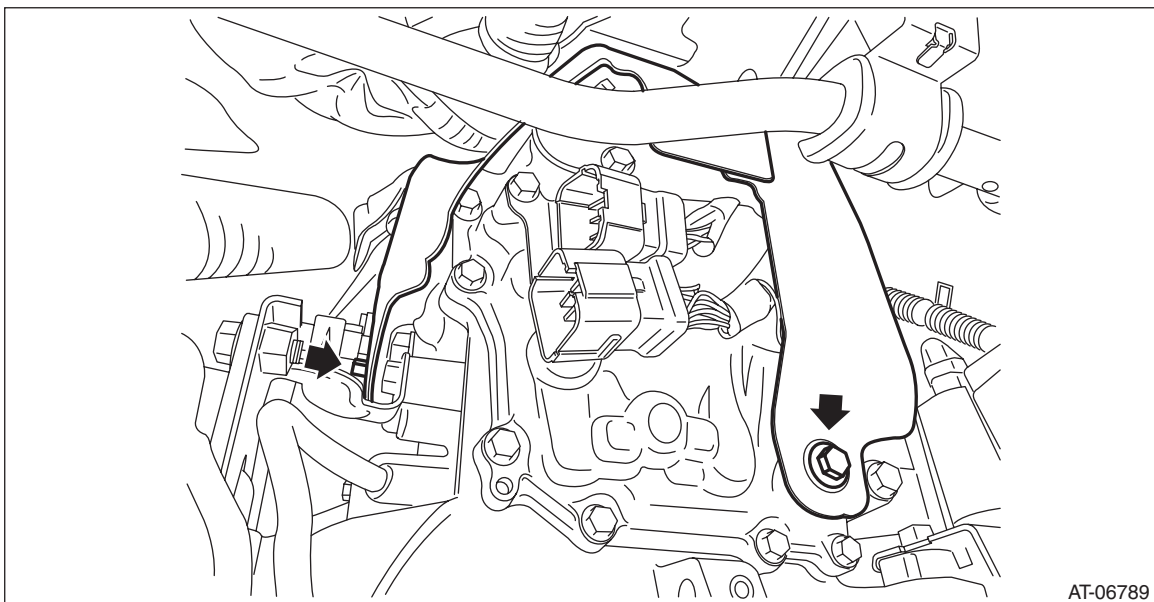

## Transmission Harness

### CONTINUOUSLY VARIABLE TRANSMISSION

12) Install the pitching stopper bracket and transmission radio ground cord.

**Tightening torque:**

**41 N·m (4.2 kgf-m, 30.2 ft-lb)**

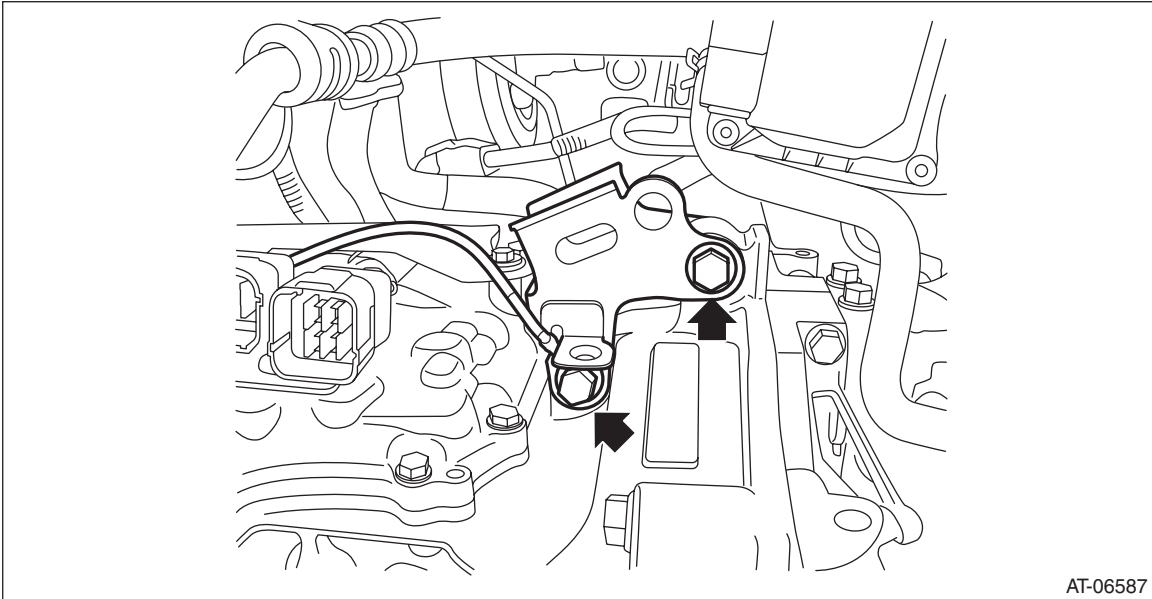

13) Install the air breather hose to the pitching stopper bracket.

14) Install the pitching stopper.

**Tightening torque:**

**T1: 50 N·m (5.1 kgf-m, 36.9 ft-lb)**

**T2: 58 N·m (5.9 kgf-m, 42.8 ft-lb)**

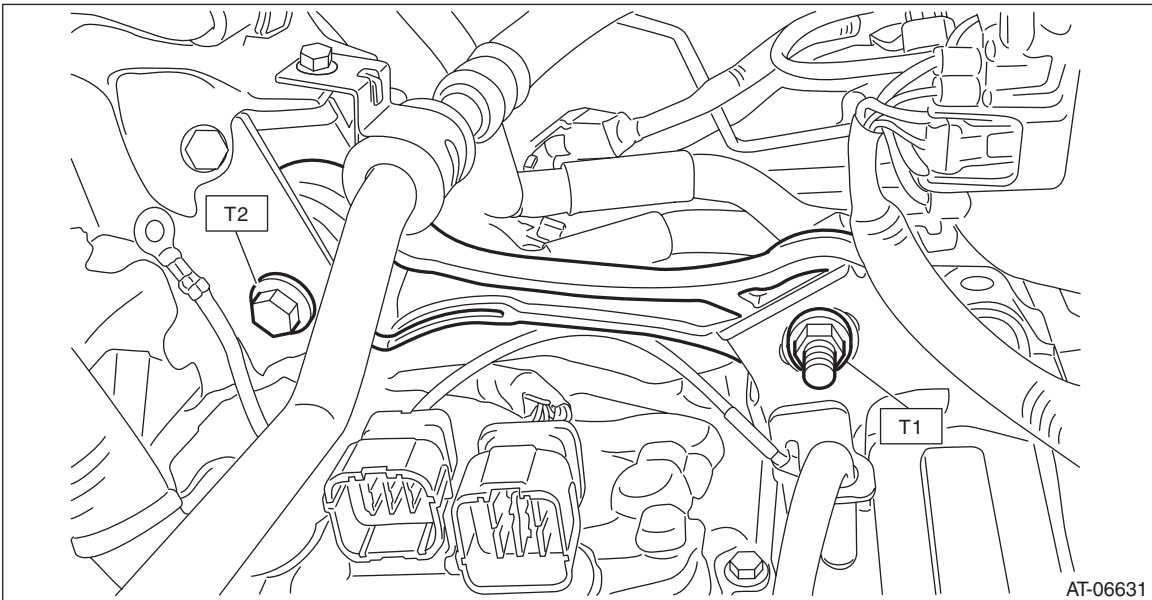

# Transmission Harness

CONTINUOUSLY VARIABLE TRANSMISSION

15) Connect the following harness connectors.

- Transmission harness connectors
- Inhibitor harness connector
- Transmission radio ground terminal

**Tightening torque:**

**13 N·m (1.3 kgf-m, 9.6 ft-lb)**

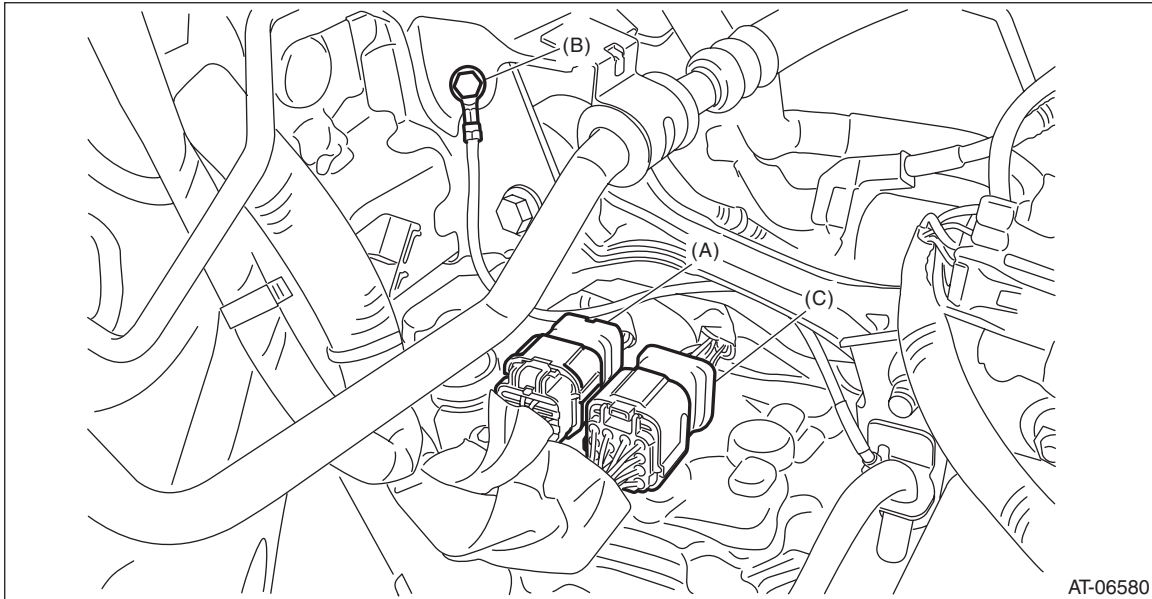

- (A) Transmission harness connectors
- (B) Transmission radio ground terminal
- (C) Inhibitor harness connector

16) Install the air intake boot assembly. <Ref. to IN(H4DO)-12, INSTALLATION, Air Intake Boot.>

17) Adjust the CVTF level. <Ref. to CVT-34, ADJUSTMENT, CVTF.>

## C: INSPECTION

- 1) Visually check the harness and connector for damage or crack.
- 2) Check the harness terminal for rust, disconnection or poor contact.
- 3) Check the continuity between harness terminals.

NOTE:

For details of transmission harness circuit, refer to wiring diagram. <Ref. to WI-66, WIRING DIAGRAM, CVT Control System.>

**Harness continuity standard**

**Less than 1  $\Omega$**