

31. Parking Pawl

A: REMOVAL

- 1) Remove the transmission assembly from the vehicle. <Ref. to CVT-56, REMOVAL, Automatic Transmission Assembly.>
- 2) Shift the range select lever to "N" range.
- 3) Remove the extension case. <Ref. to CVT-156, REMOVAL, Extension Case.>
- 4) Remove the parking pawl shaft, return spring and parking pawl.

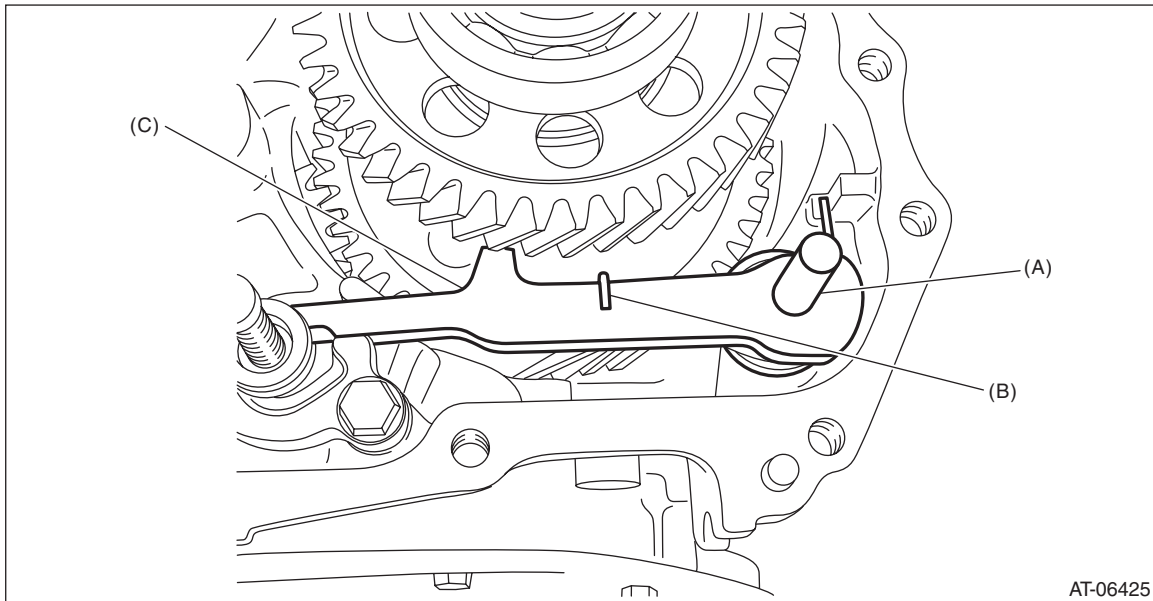

- (A) Parking pawl shaft
- (B) Return spring
- (C) Parking pawl

Parking Pawl

CONTINUOUSLY VARIABLE TRANSMISSION

B: INSTALLATION

- 1) Set the range select lever to the “N” range.
- 2) Install the parking pawl shaft, return spring and parking pawl.

NOTE:

Make sure that the end of return spring sticks out of parking pawl as shown in (a). Make sure that the other end contacts the rib of transmission case as shown in (b).

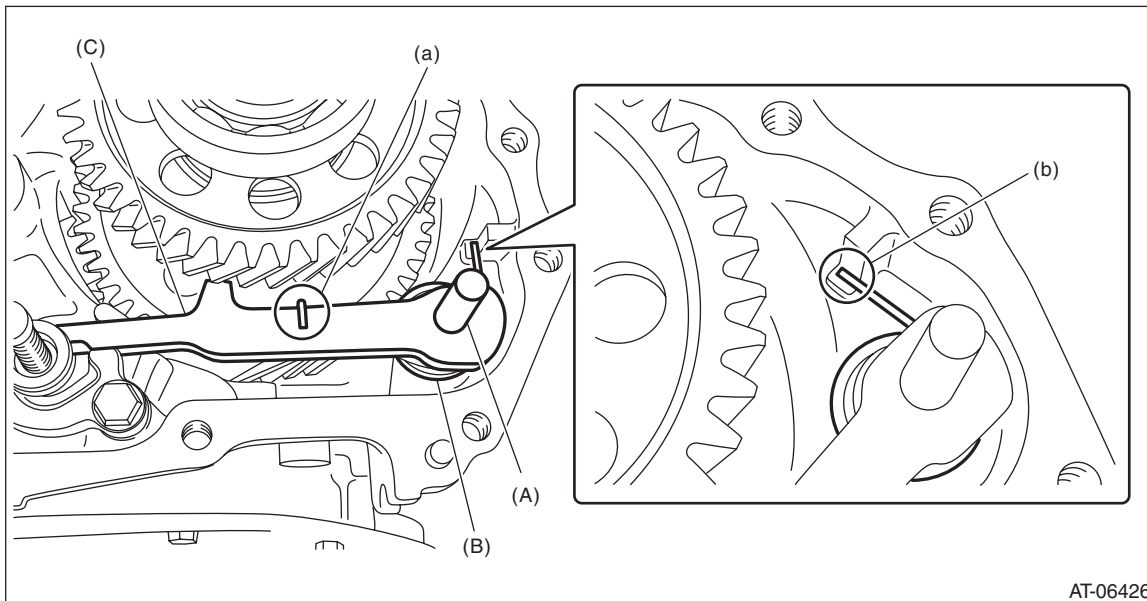

- (A) Parking pawl shaft
- (B) Return spring
- (C) Parking pawl

- 3) Install the extension case. <Ref. to CVT-157, INSTALLATION, Extension Case.>
- 4) Install the transmission assembly to the vehicle. <Ref. to CVT-67, INSTALLATION, Automatic Transmission Assembly.>

C: INSPECTION

- Check the parking pawl for breakage or damage.
- Check for worn, broken and/or damaged return spring.