

32.Reduction Driven Gear

A: REMOVAL

- 1) Remove the transmission assembly from the vehicle. <Ref. to CVT-56, REMOVAL, Automatic Transmission Assembly.>
- 2) Remove the extension case. <Ref. to CVT-156, REMOVAL, Extension Case.>
- 3) Remove the transfer clutch assembly. <Ref. to CVT-160, REMOVAL, Transfer Clutch.>
- 4) Remove the transfer driven gear assembly. <Ref. to CVT-174, REMOVAL, Transfer Driven Gear.>
- 5) Remove the parking pawl. <Ref. to CVT-177, REMOVAL, Parking Pawl.>
- 6) Remove the reduction driven gear assembly.

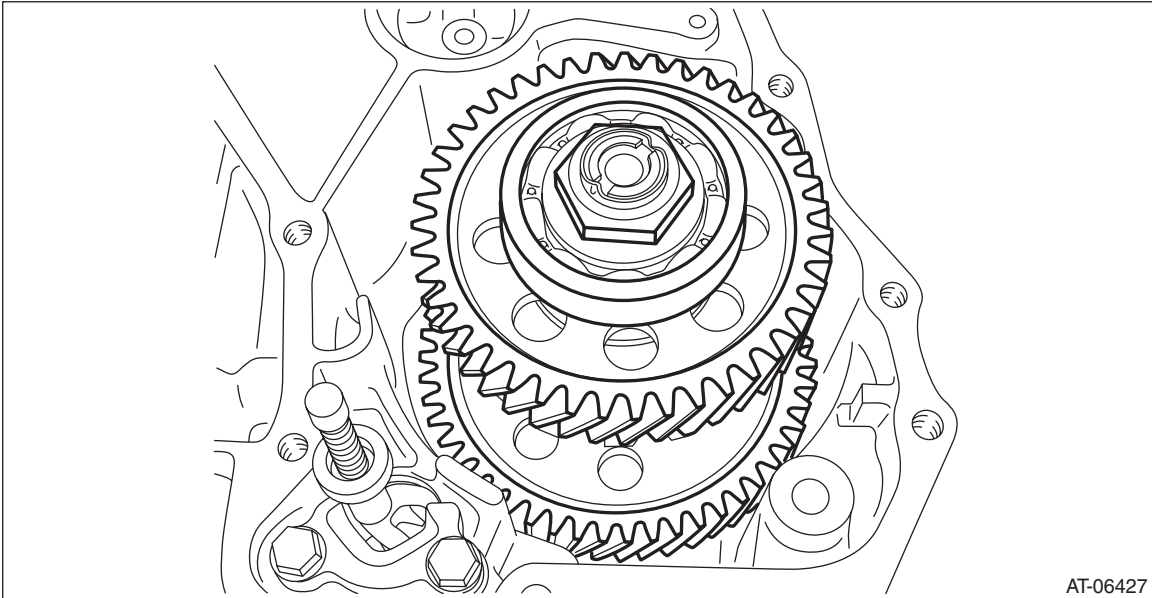

B: INSTALLATION

- 1) Install the reduction driven gear assembly.

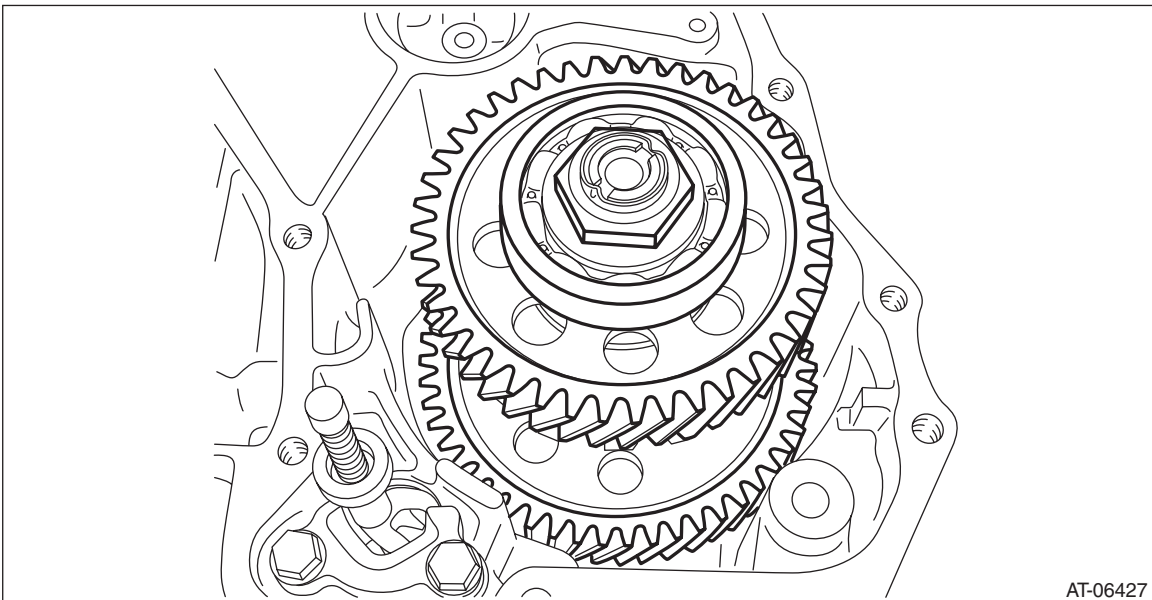

- 2) Select the transfer drive gear shim. <Ref. to CVT-208, ADJUSTMENT, Reduction Drive Gear.>
- 3) Install the parking pawl. <Ref. to CVT-178, INSTALLATION, Parking Pawl.>
- 4) Attach the selected transfer drive gear shim to extension case with vaseline.
- 5) Install the transfer driven gear assembly. <Ref. to CVT-175, INSTALLATION, Transfer Driven Gear.>
- 6) Install the transfer clutch assembly. <Ref. to CVT-162, INSTALLATION, Transfer Clutch.>

Reduction Driven Gear

CONTINUOUSLY VARIABLE TRANSMISSION

- 7) Install the extension case. <Ref. to CVT-157, INSTALLATION, Extension Case.>
- 8) Install the transmission assembly to the vehicle. <Ref. to CVT-67, INSTALLATION, Automatic Transmission Assembly.>

C: DISASSEMBLY

- 1) Flatten the tab of the lock nut.
- 2) Using the ST, counter the rotation of the reduction driven gear assembly, and remove the lock nut.

ST1 18355AA000 PULLEY WRENCH
ST2 18334AA000 PIN SET
ST3 499987003 SOCKET WRENCH (35)

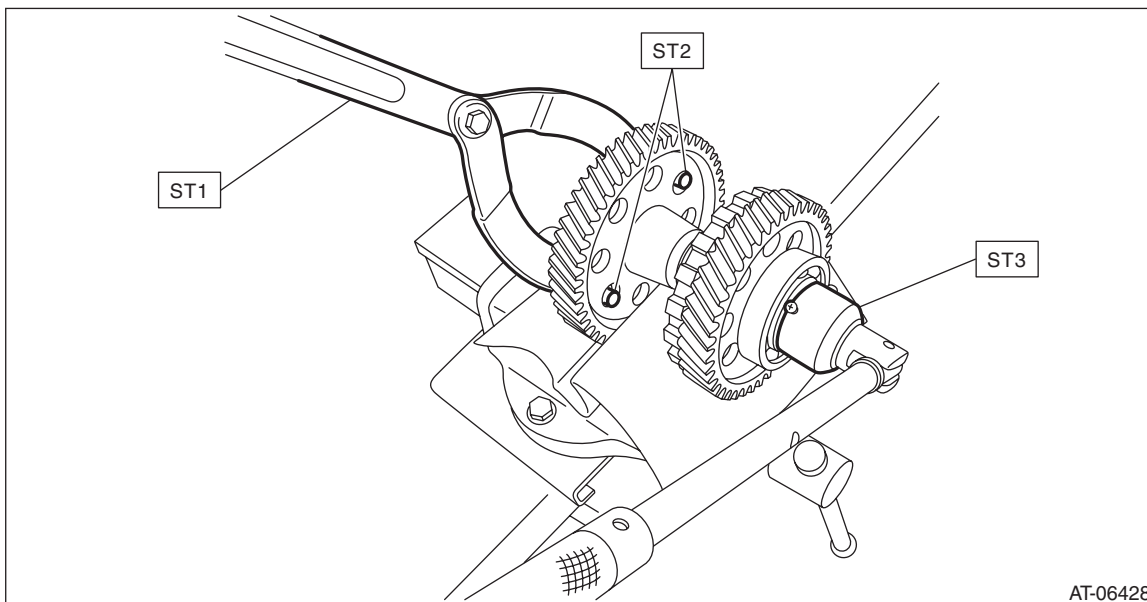

- 3) Remove the ball bearing using ST.

ST1 499757002 INSTALLER
ST2 498077300 REMOVER

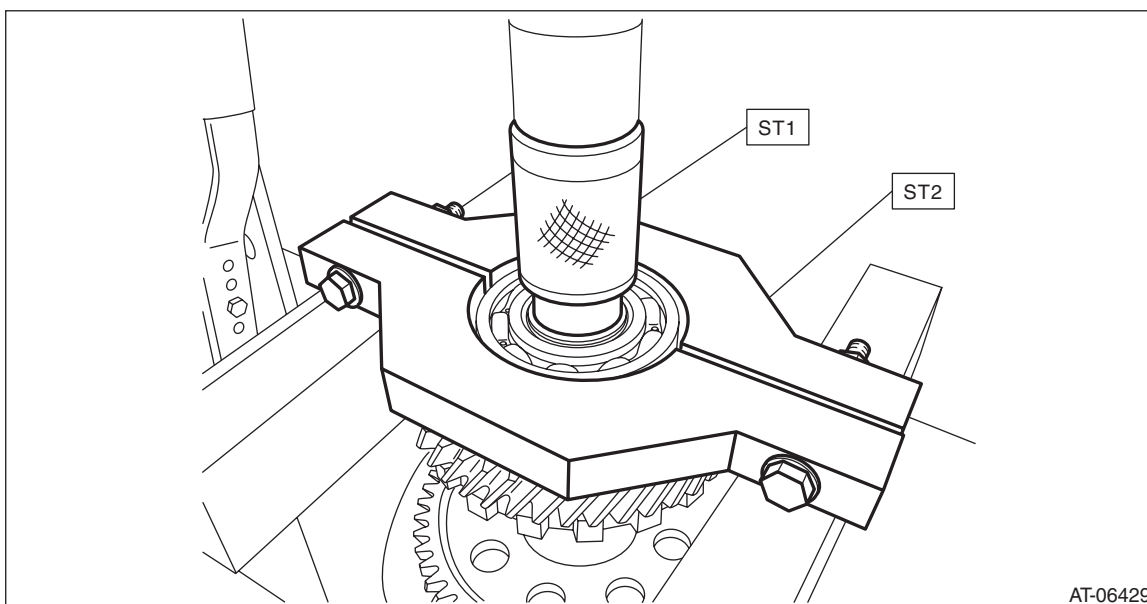

Reduction Driven Gear

CONTINUOUSLY VARIABLE TRANSMISSION

4) Using the ST, remove the parking gear and transfer drive gear.

ST 899864100 REMOVER

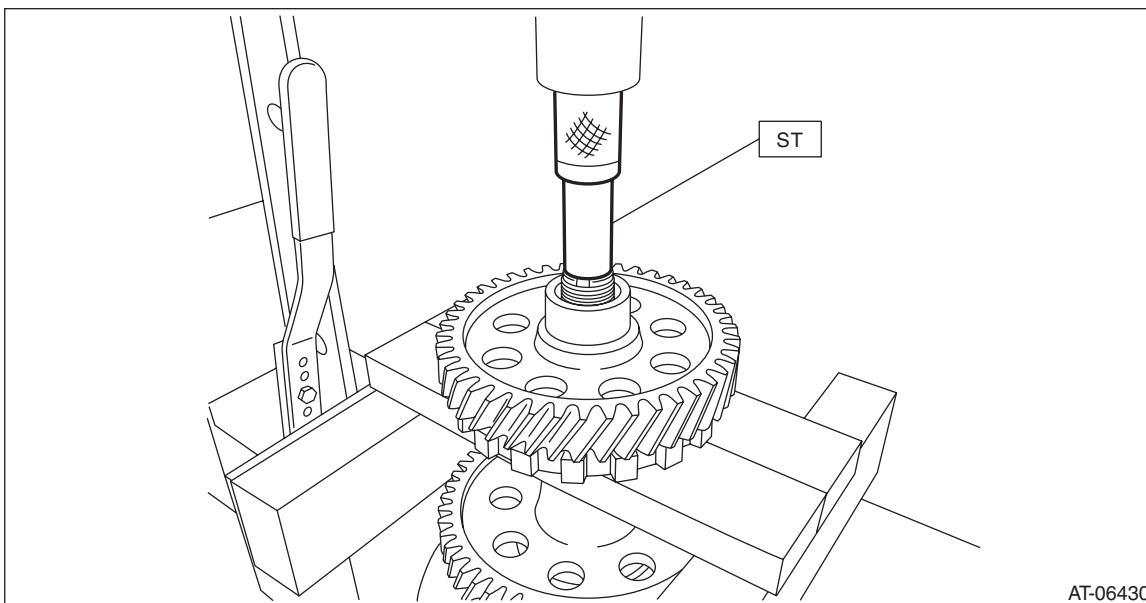

5) Remove the collar.

NOTE:

When collar has been removed, do not reuse the reduction driven gear and/or shaft, and replace it with reduction driven gear COMPL.

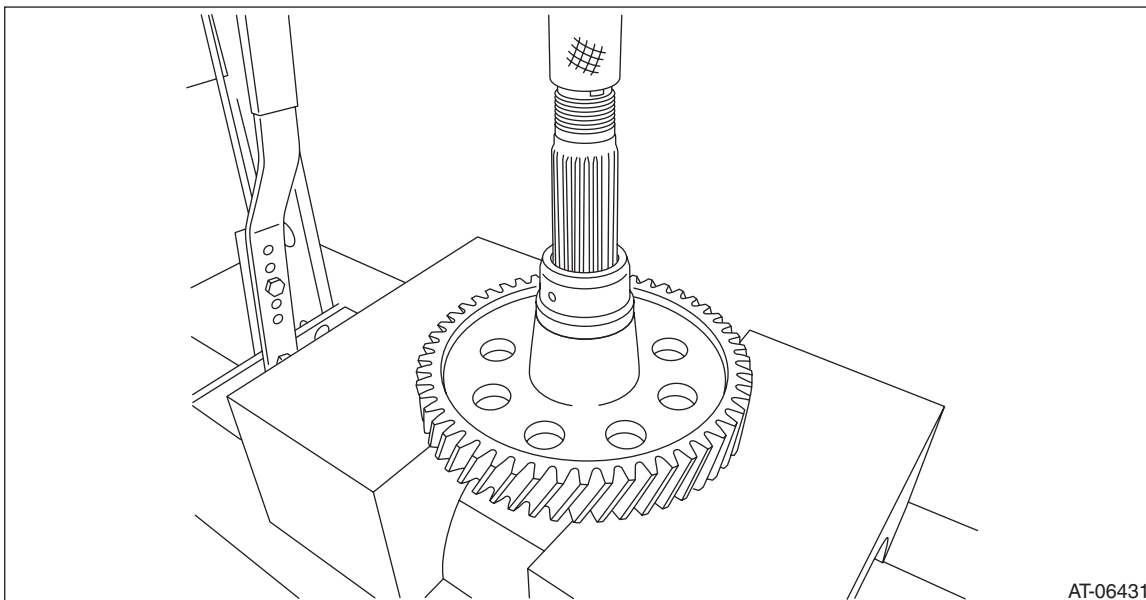

Reduction Driven Gear

CONTINUOUSLY VARIABLE TRANSMISSION

D: ASSEMBLY

1) Using the ST, attach the collar.

NOTE:

- Attach the collar in the correct direction.
- Use a new reduction driven gear COMPL.

ST 899580100 INSTALLER

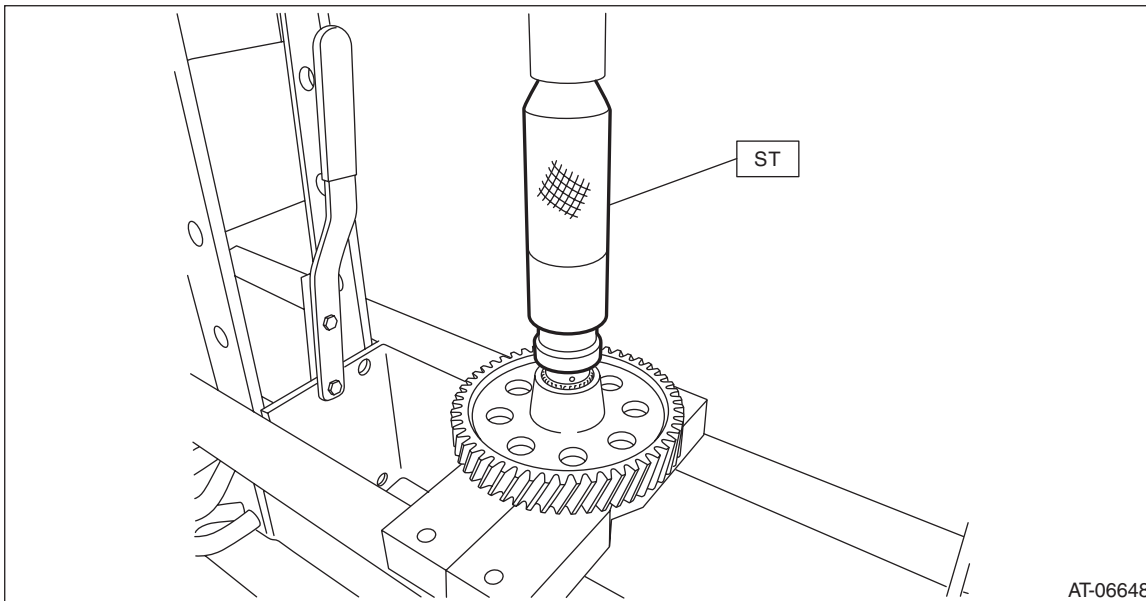

AT-06648

2) Using the ST, install the parking gear.

ST 499757002 INSTALLER

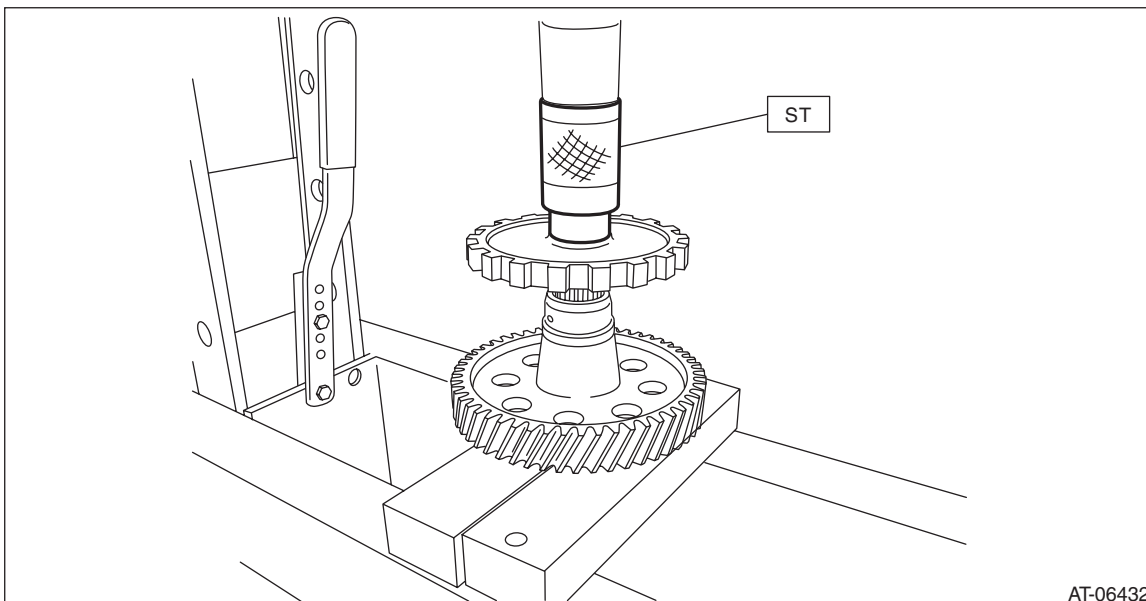

AT-06432

Reduction Driven Gear

CONTINUOUSLY VARIABLE TRANSMISSION

3) Using the ST, install the transfer drive gear.

ST 499757002 INSTALLER

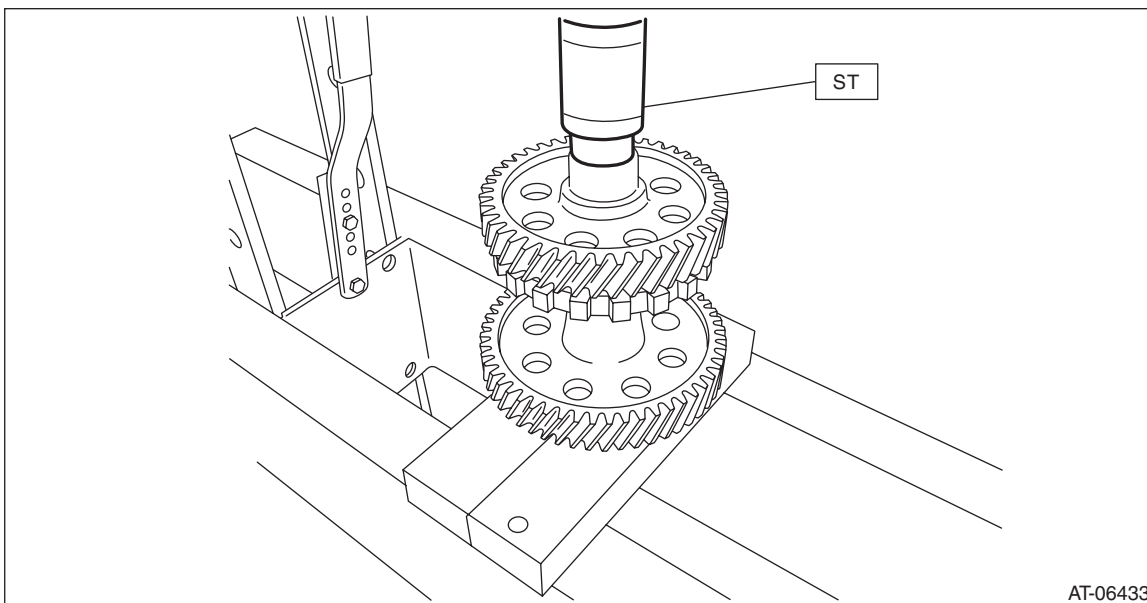

AT-06433

4) Using the ST, install the ball bearing.

NOTE:

Use a new ball bearing.

ST 499277100 BUSHING 1-2 INSTALLER

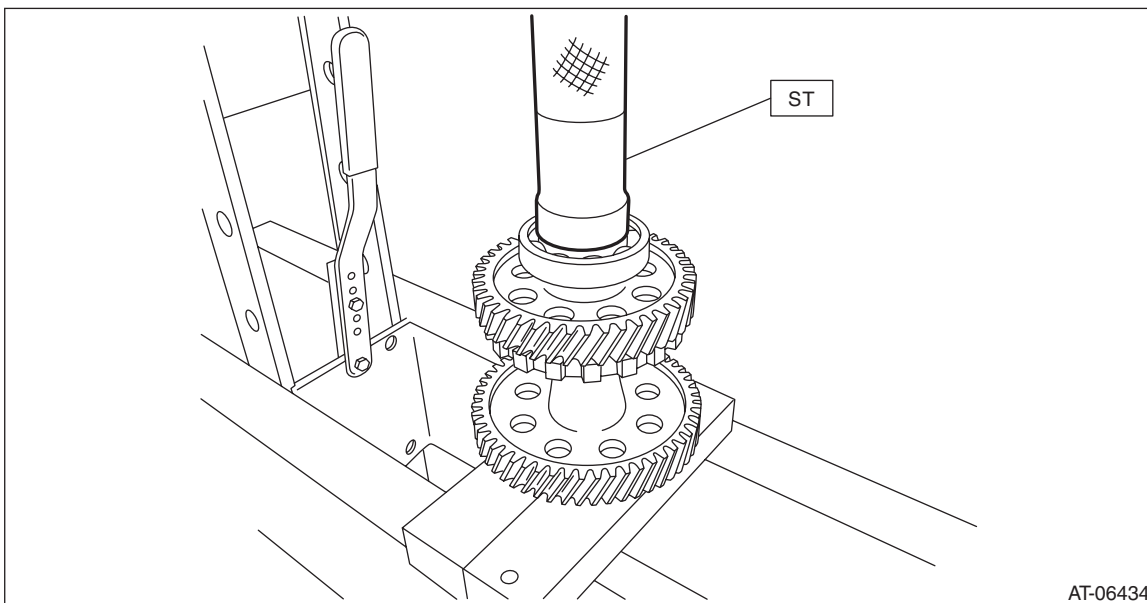

AT-06434

Reduction Driven Gear

CONTINUOUSLY VARIABLE TRANSMISSION

5) Using the ST, counter the rotation of the reduction drive gear assembly, and install the lock nut.

NOTE:

Use a new lock nut.

ST1 18355AA000 PULLEY WRENCH

ST2 18334AA000 PIN SET

ST3 499987003 SOCKET WRENCH (35)

Tightening torque:

95 N·m (9.7 kgf·m, 70.1 ft·lb)

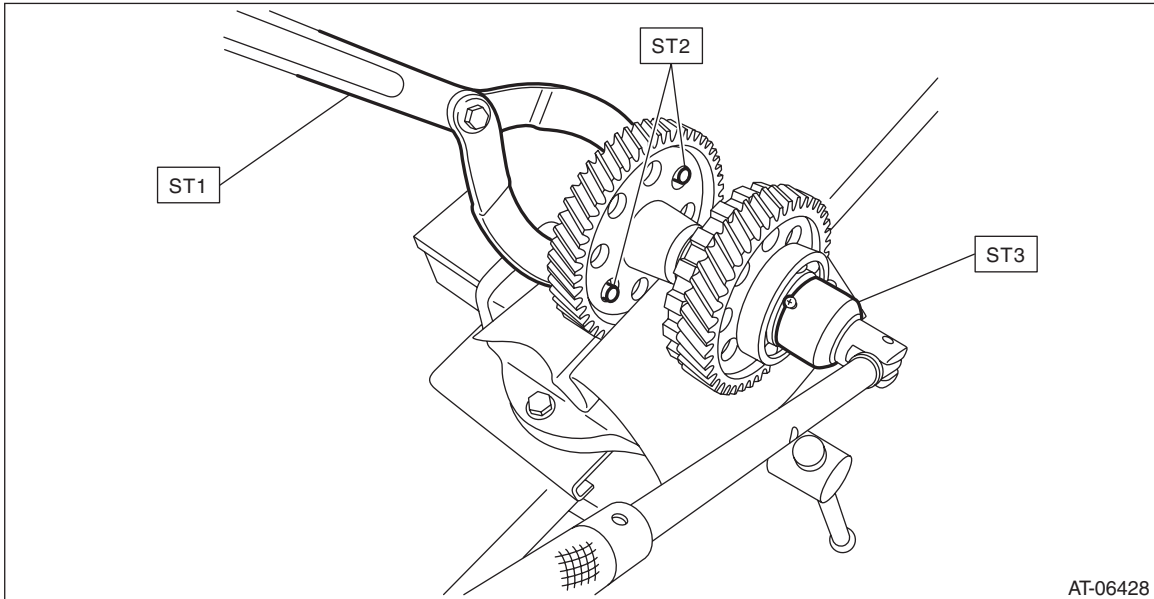

6) Crimp the lock nut in 4 locations.

CAUTION:

Do not allow the lock nut to be cracked during crimping operation.

E: INSPECTION

- Check the ball bearing for smooth rotation.
- Check the ball bearing for excessive looseness.
- Make sure each gear is not broken or damaged.

Reduction Driven Gear

CONTINUOUSLY VARIABLE TRANSMISSION

F: ADJUSTMENT

1) Measure the height "A" from the ST upper face to the ball bearing catch surface.

ST 499575600 GAUGE

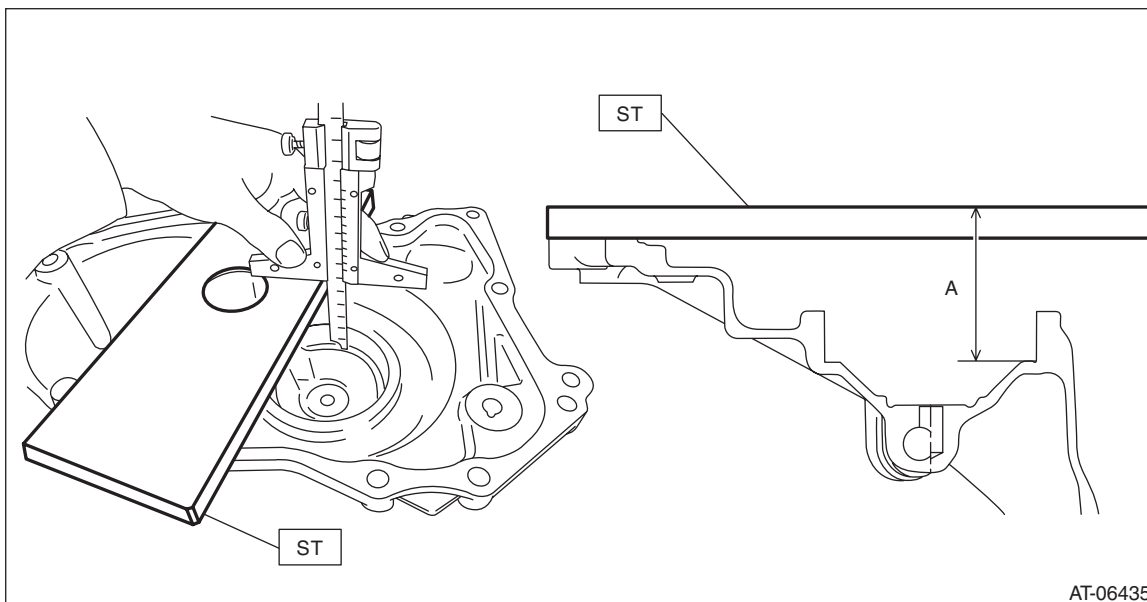

AT-06435

2) Measure the height "B" from the ST to the mating surface of the transmission case.

ST 499575600 GAUGE

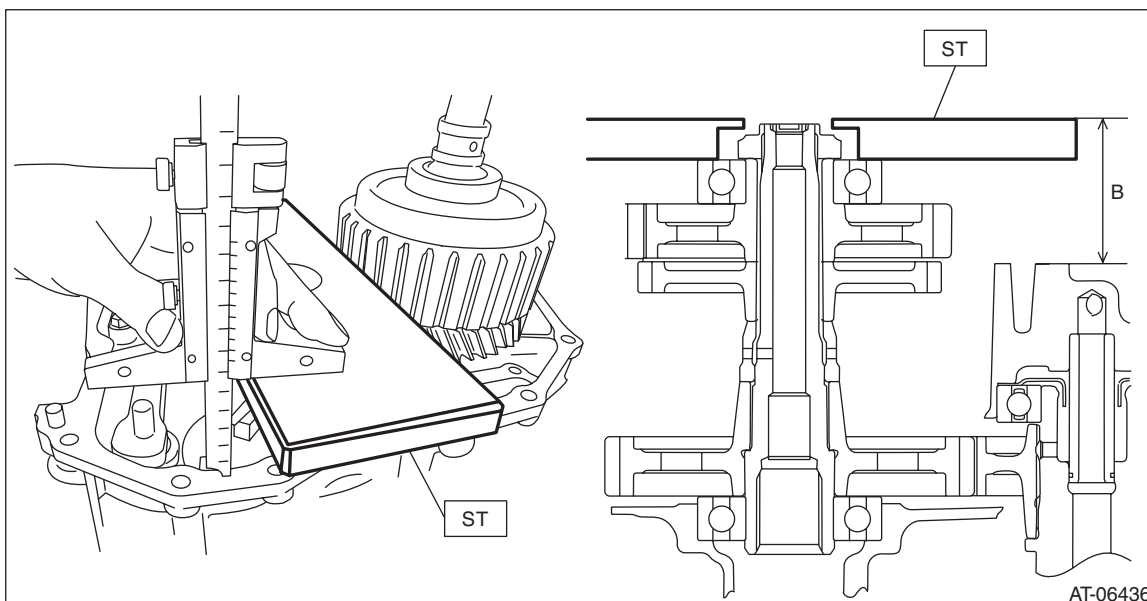

AT-06436

Reduction Driven Gear

CONTINUOUSLY VARIABLE TRANSMISSION

3) Obtain the thickness of transfer drive gear shim using the following formula to select one to three transfer drive gear shims.

$$T \text{ (mm)} = A - B - (0.05 \text{ — } 0.25)$$

$$[T \text{ (in)} = A - B - (0.002 \text{ — } 0.01)]$$

T: Shim thickness

A: Height from the ST upper face to the ball bearing catch surface

B: Height from ST to transmission case mating surface

0.05 — 0.25 mm (0.002 — 0.01 in): Clearance

| Transfer drive gear shim | |
|--------------------------|-------------------|
| Part No. | Thickness mm (in) |
| 33279AA090 | 0.3 (0.012) |
| 33279AA100 | 0.4 (0.016) |
| 33279AA110 | 0.5 (0.020) |