

34. Transmission Case

A: REMOVAL

- 1) Remove the transmission assembly from the vehicle. <Ref. to CVT-56, REMOVAL, Automatic Transmission Assembly.>
- 2) Remove the air breather hose. <Ref. to CVT-148, REMOVAL, Air Breather Hose.>
- 3) Remove the control valve body. <Ref. to CVT-110, REMOVAL, Control Valve Body.>
- 4) Remove the transmission harness. <Ref. to CVT-124, REMOVAL, Transmission Harness.>
- 5) Remove the turbine speed sensor. <Ref. to CVT-97, REMOVAL, Turbine Speed Sensor.>
- 6) Remove the secondary speed sensor. <Ref. to CVT-99, REMOVAL, Secondary Speed Sensor.>
- 7) Remove the primary speed sensor. <Ref. to CVT-101, REMOVAL, Primary Speed Sensor.>
- 8) Remove the inhibitor switch. <Ref. to CVT-93, REMOVAL, Inhibitor Switch.>
- 9) Remove the extension case. <Ref. to CVT-156, REMOVAL, Extension Case.>
- 10) Remove the transfer clutch assembly. <Ref. to CVT-160, REMOVAL, Transfer Clutch.>
- 11) Remove the transfer driven gear assembly. <Ref. to CVT-174, REMOVAL, Transfer Driven Gear.>
- 12) Remove the parking pawl. <Ref. to CVT-177, REMOVAL, Parking Pawl.>
- 13) Remove the reduction driven gear assembly. <Ref. to CVT-179, REMOVAL, Reduction Driven Gear.>
- 14) Remove the oil pan and oil strainer. <Ref. to CVT-106, REMOVAL, Oil Pan and Strainer.>
- 15) Remove the transmission control device. <Ref. to CVT-187, REMOVAL, Transmission Control Device.>
- 16) Remove the oil baffle securing bolt.

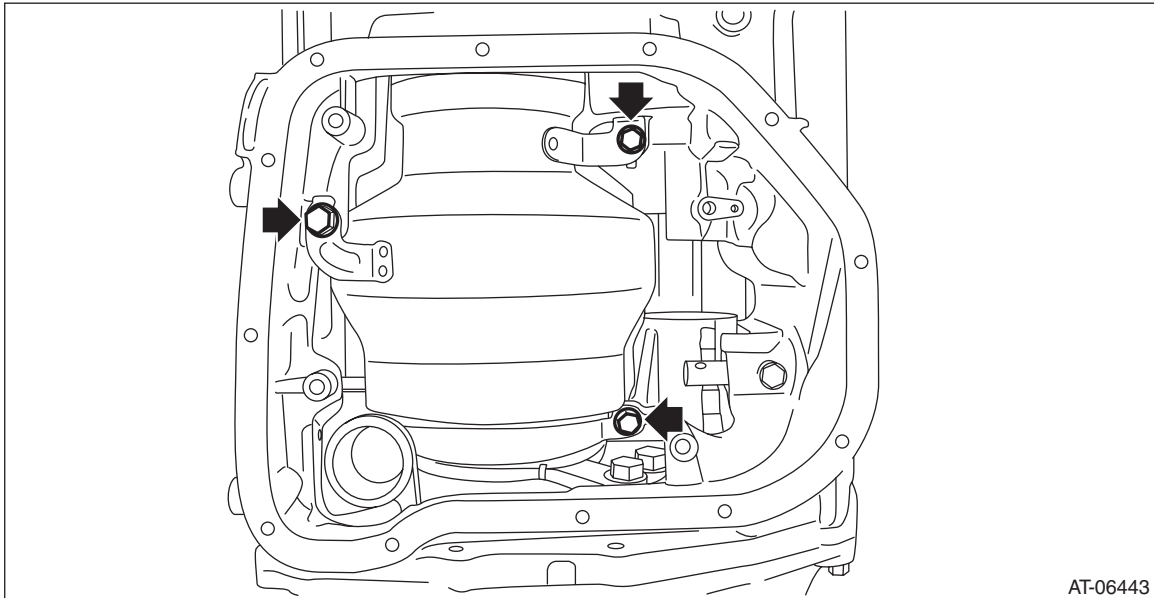

AT-06443

Transmission Case

CONTINUOUSLY VARIABLE TRANSMISSION

17) Remove the oil cooler pipe.

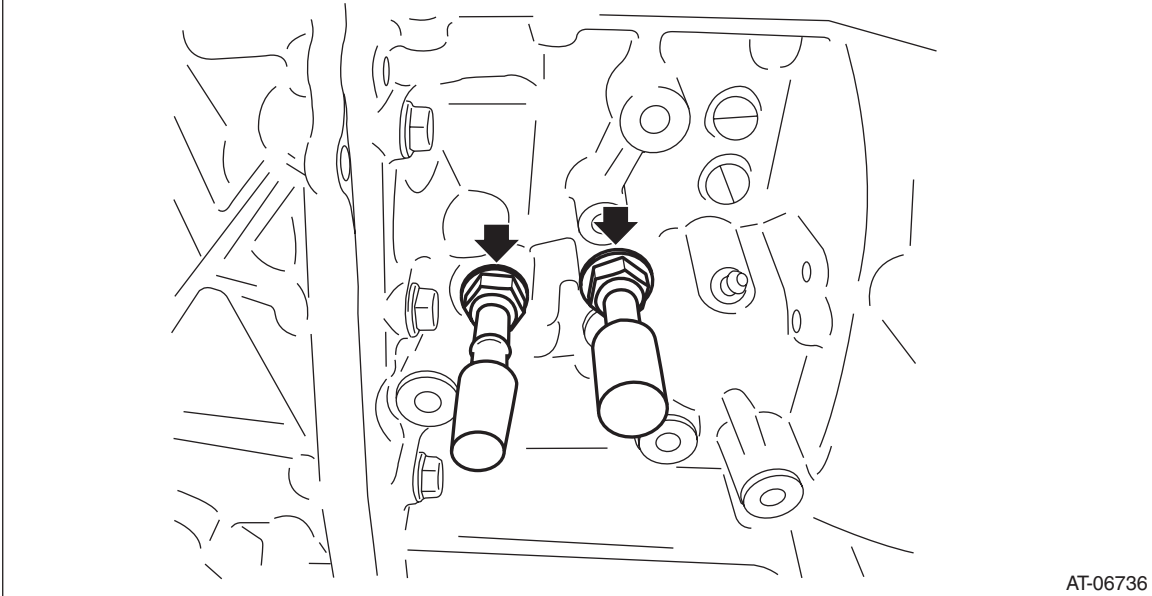

AT-06736

18) Remove the transmission case.

NOTE:

The total number of transmission case mounting bolts is 15.

19) Remove the oil baffle.

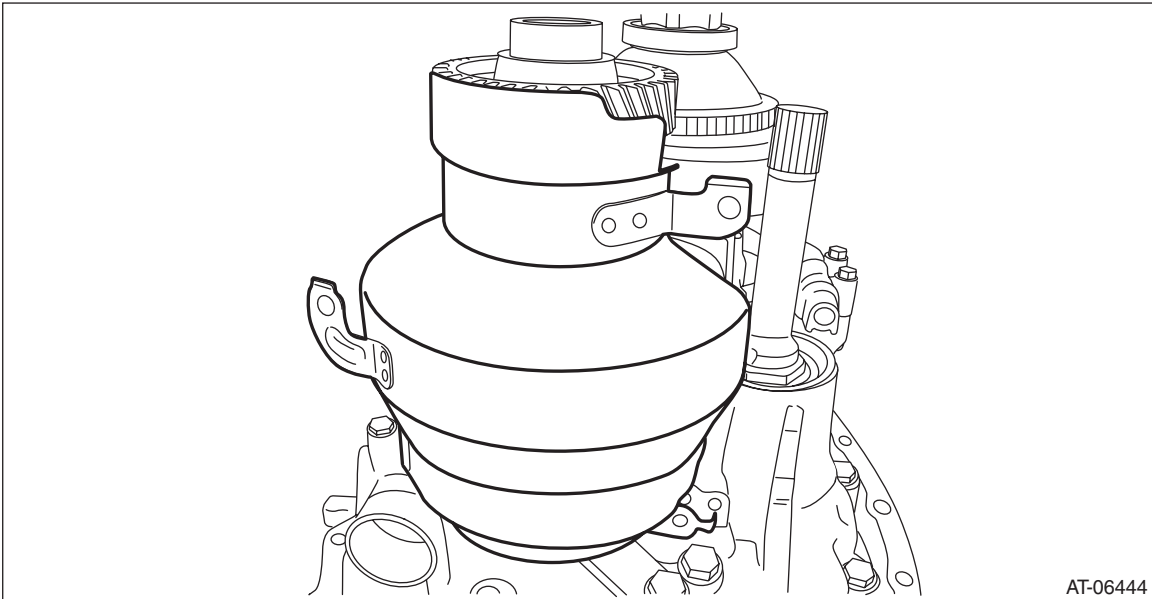

AT-06444

Transmission Case

CONTINUOUSLY VARIABLE TRANSMISSION

20) Remove the O-ring.

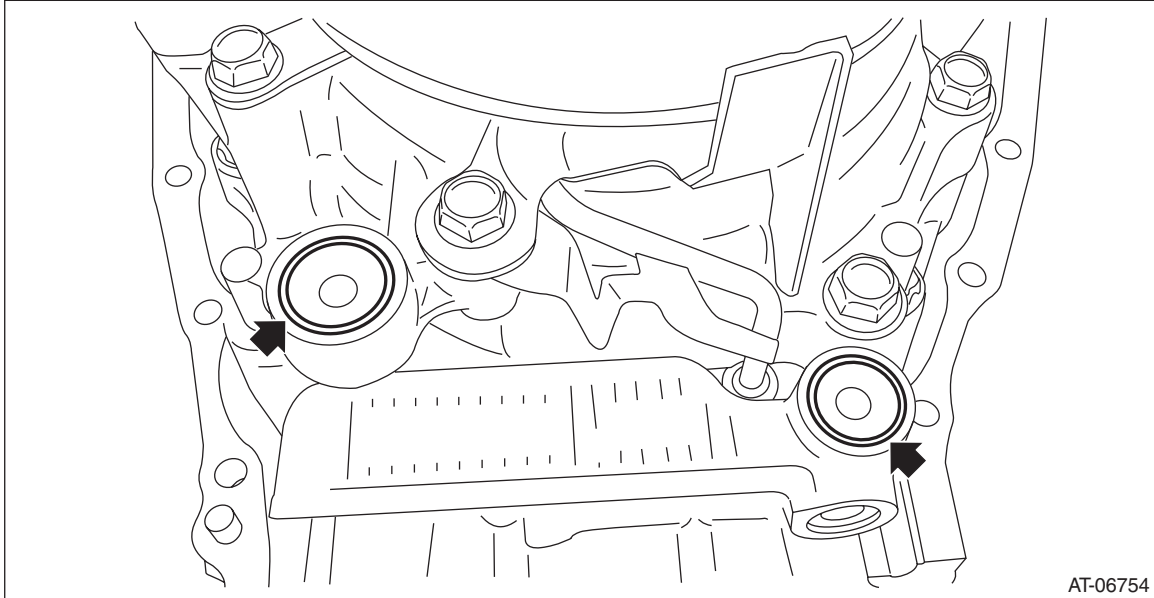

AT-06754

21) Remove the seal ring from the transmission case.

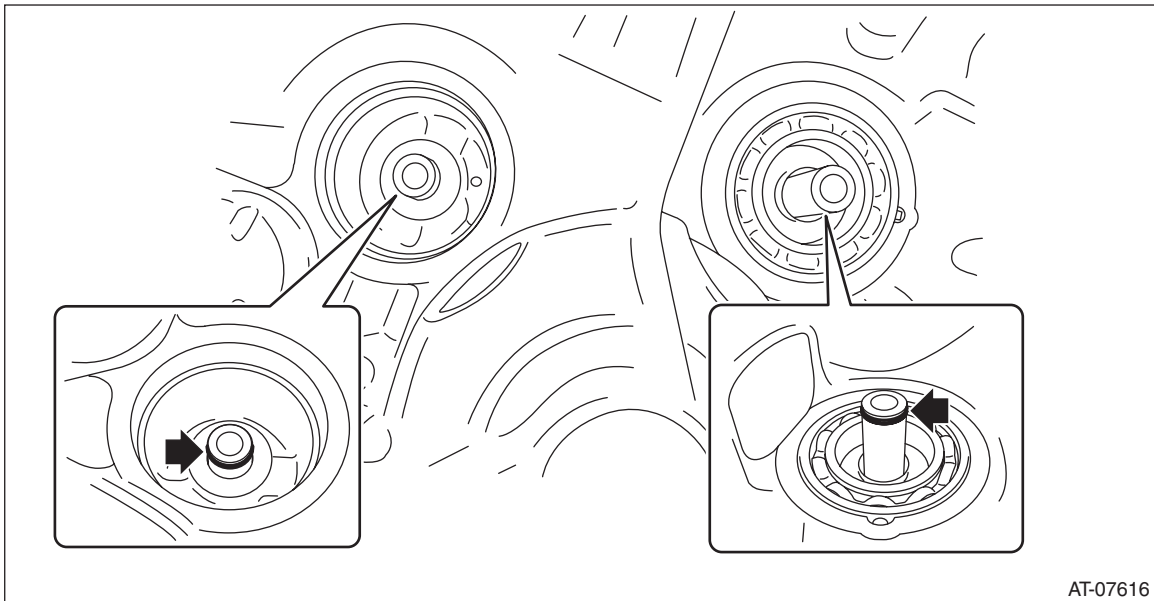

AT-07616

Transmission Case

CONTINUOUSLY VARIABLE TRANSMISSION

B: INSTALLATION

- 1) Clean the mating surface of transmission case and converter case.
- 2) Select the reduction gear shim. <Ref. to CVT-208, ADJUSTMENT, Reduction Drive Gear.>
- 3) Remove the transmission case, and install the selected reduction gear shim to the reduction drive gear.
- 4) Install the O-rings to the reverse clutch housing and drive pinion retainer.

NOTE:

- Use new O-rings.
- Apply CVTF to the O-ring.

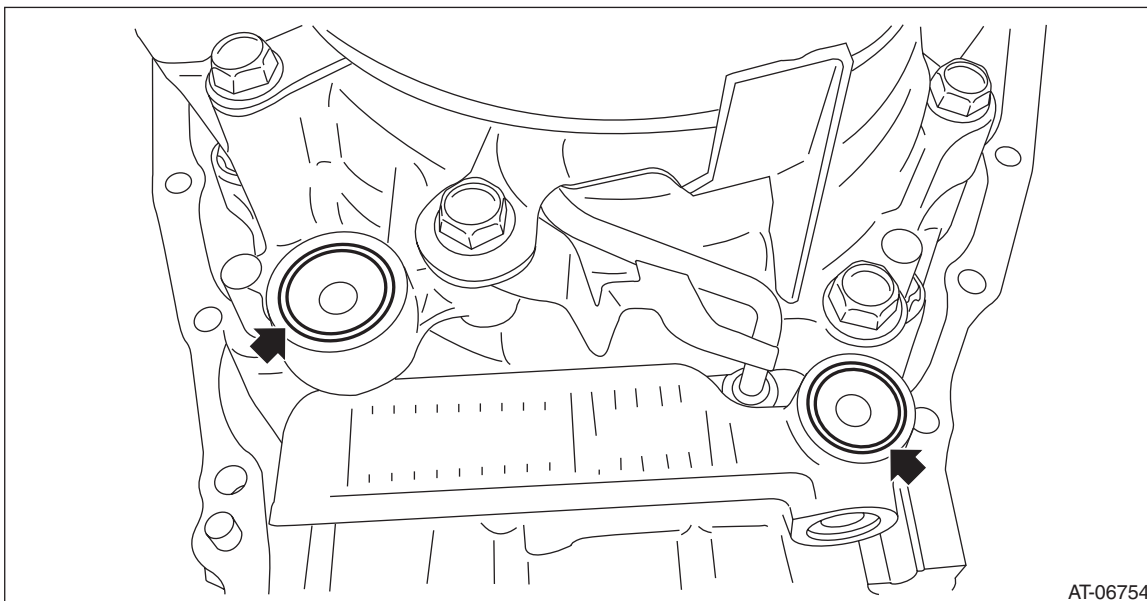

- 5) Install the seal ring to the transmission case.

NOTE:

- Use a new seal ring.
- Apply CVTF to the seal rings.

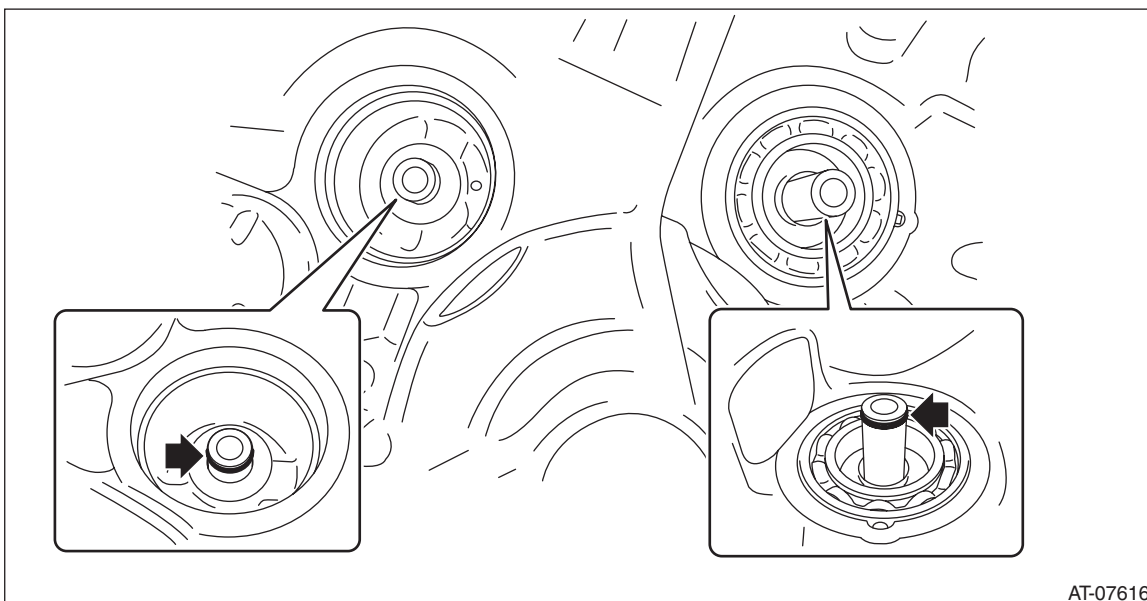

Transmission Case

CONTINUOUSLY VARIABLE TRANSMISSION

- 6) Cover the secondary pulley with the oil baffle, and temporarily install it with bolts.

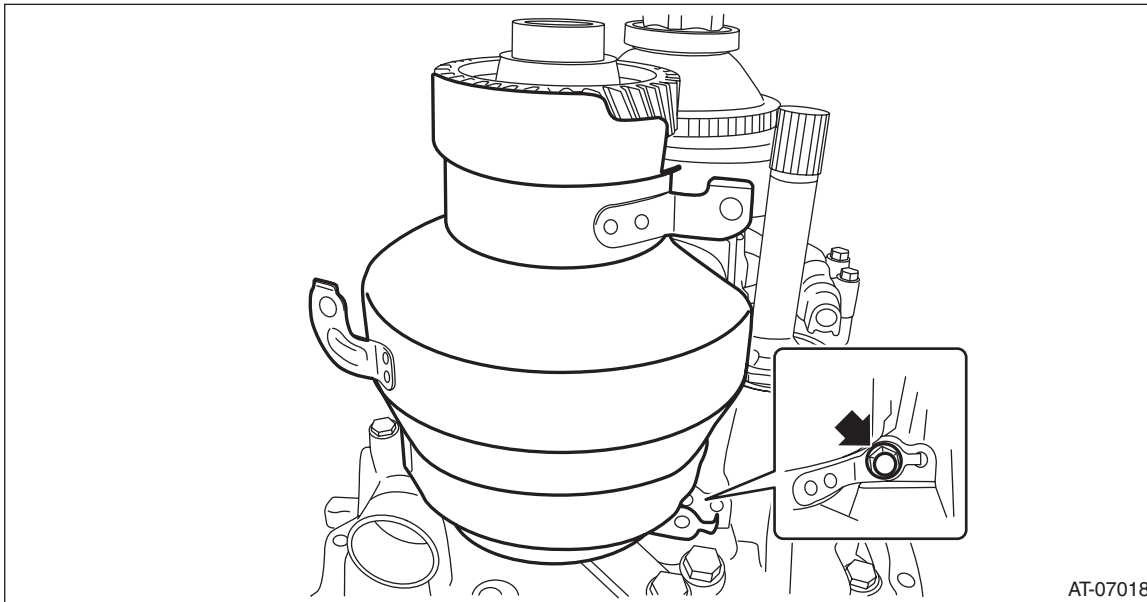

- 7) Apply liquid gasket seamlessly to the mating surface of transmission case.

Liquid gasket:

THREE BOND 1215 (Part No. 004403007) or equivalent

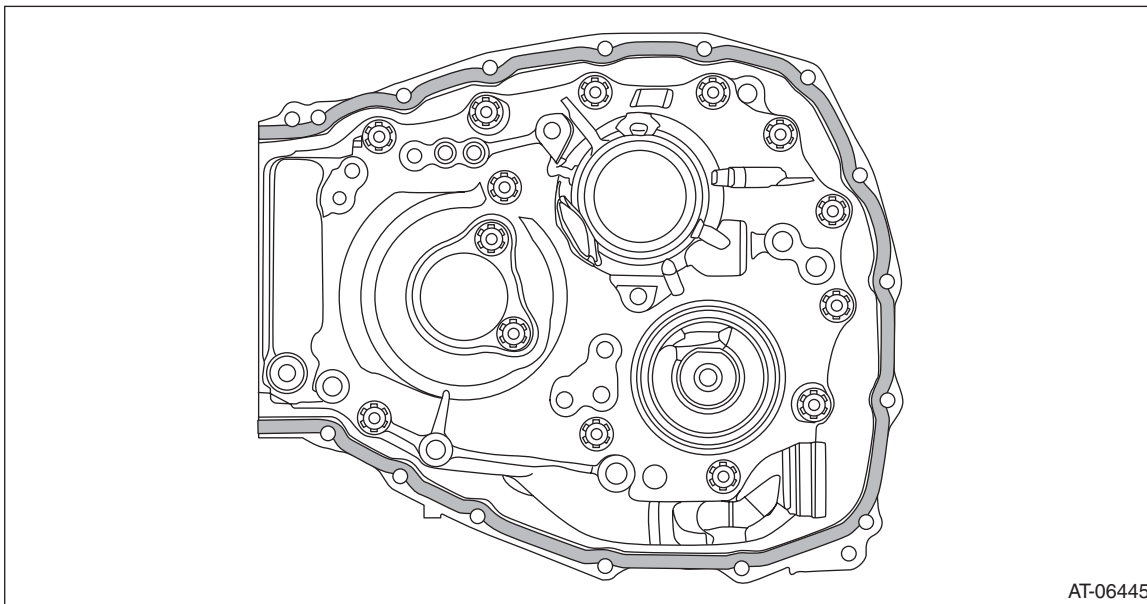

- 8) Install the transmission case.

NOTE:

The total number of transmission case mounting bolts is 15.

Tightening torque:

22 N·m (2.2 kgf·m, 16.2 ft·lb)

Transmission Case

CONTINUOUSLY VARIABLE TRANSMISSION

9) Install the oil cooler pipe.

NOTE:

Use new O-rings.

Tightening torque:

25 N·m (2.5 kgf·m, 18.4 ft·lb)

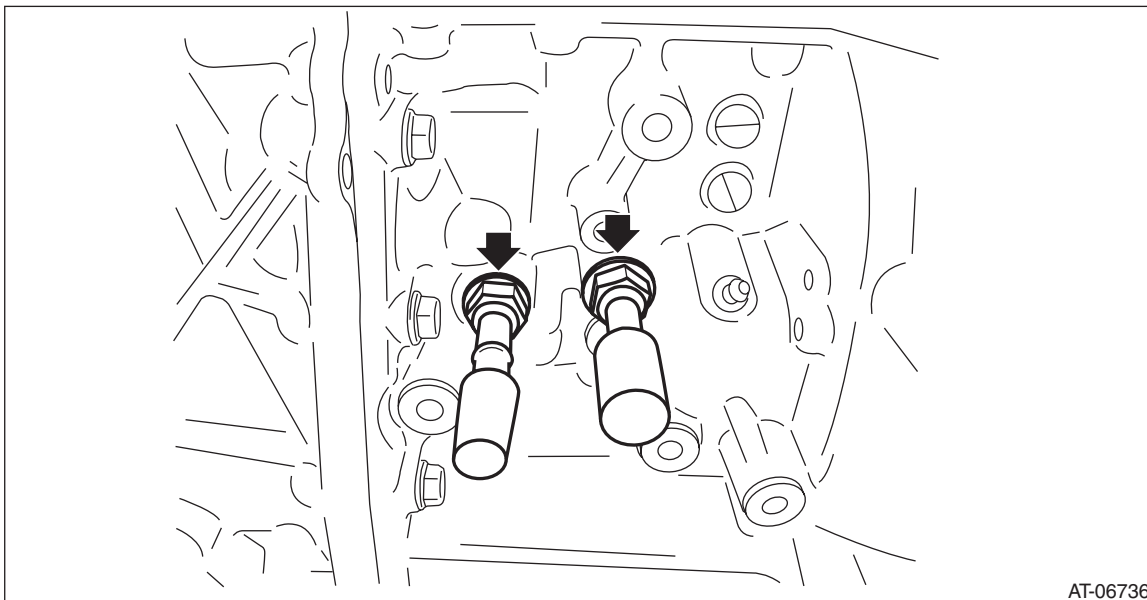

10) Install the oil baffle securing bolt.

Tightening torque:

16 N·m (1.6 kgf·m, 11.8 ft·lb)

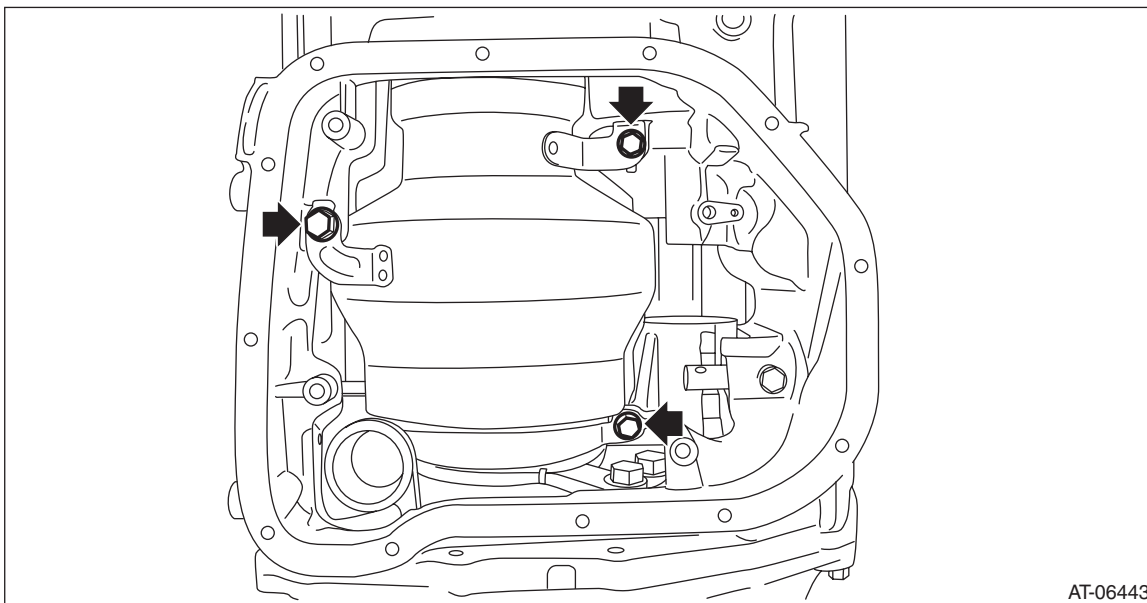

11) Install the transmission control device. <Ref. to CVT-190, INSTALLATION, Transmission Control Device.>

12) Install the oil pan and oil strainer. <Ref. to CVT-107, INSTALLATION, Oil Pan and Strainer.>

13) Install the reduction driven gear assembly. <Ref. to CVT-179, INSTALLATION, Reduction Driven Gear.>

14) Install the parking pawl. <Ref. to CVT-178, INSTALLATION, Parking Pawl.>

15) Install the transfer driven gear assembly. <Ref. to CVT-175, INSTALLATION, Transfer Driven Gear.>

Transmission Case

CONTINUOUSLY VARIABLE TRANSMISSION

- 16) Install the transfer clutch assembly. <Ref. to CVT-162, INSTALLATION, Transfer Clutch.>
- 17) Install the extension case. <Ref. to CVT-157, INSTALLATION, Extension Case.>
- 18) Install the inhibitor switch. <Ref. to CVT-95, INSTALLATION, Inhibitor Switch.>
- 19) Install the secondary speed sensor. <Ref. to CVT-99, INSTALLATION, Secondary Speed Sensor.>
- 20) Install the primary speed sensor. <Ref. to CVT-102, INSTALLATION, Primary Speed Sensor.>
- 21) Install the turbine speed sensor. <Ref. to CVT-97, INSTALLATION, Turbine Speed Sensor.>
- 22) Install the transmission harness. <Ref. to CVT-130, INSTALLATION, Transmission Harness.>
- 23) Install the control valve body. <Ref. to CVT-116, INSTALLATION, Control Valve Body.>
- 24) Install the air breather hose. <Ref. to CVT-149, INSTALLATION, Air Breather Hose.>
- 25) Install the transmission assembly to the vehicle. <Ref. to CVT-67, INSTALLATION, Automatic Transmission Assembly.>

C: DISASSEMBLY

- 1) Remove the oil stopper plate.

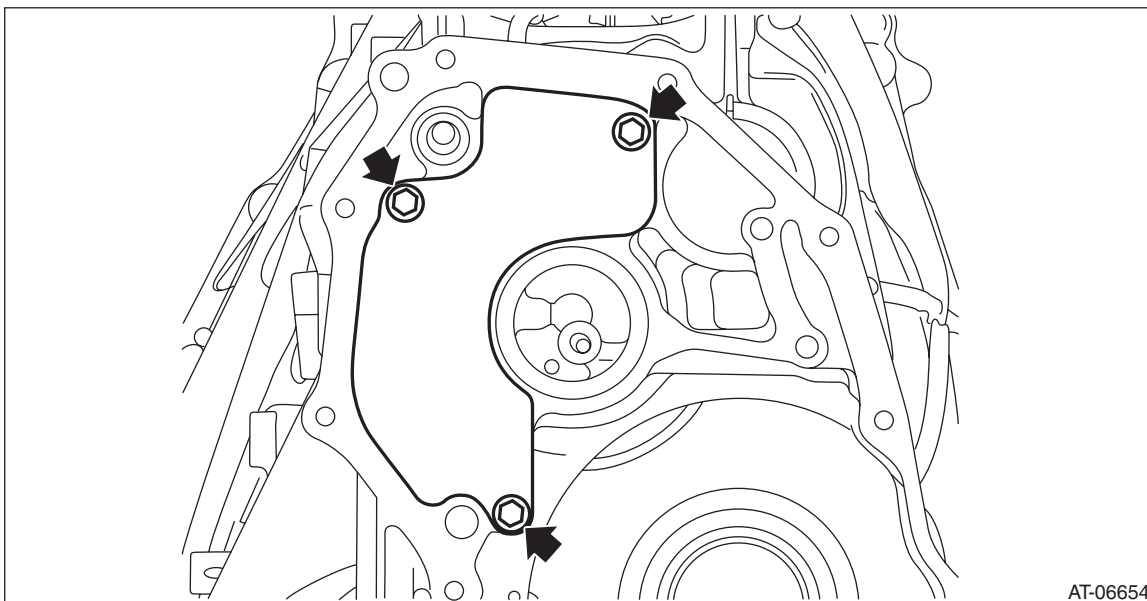

- 2) Remove all plugs from the transmission case.

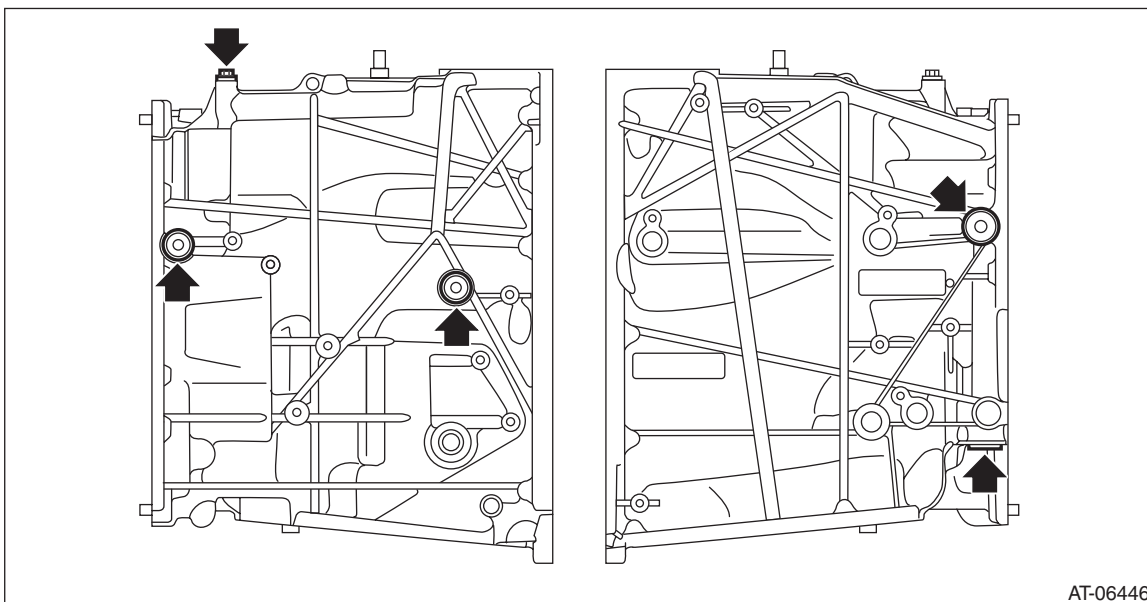

Transmission Case

CONTINUOUSLY VARIABLE TRANSMISSION

3) Remove the oil seal using a screwdriver wrapped with cloth etc.

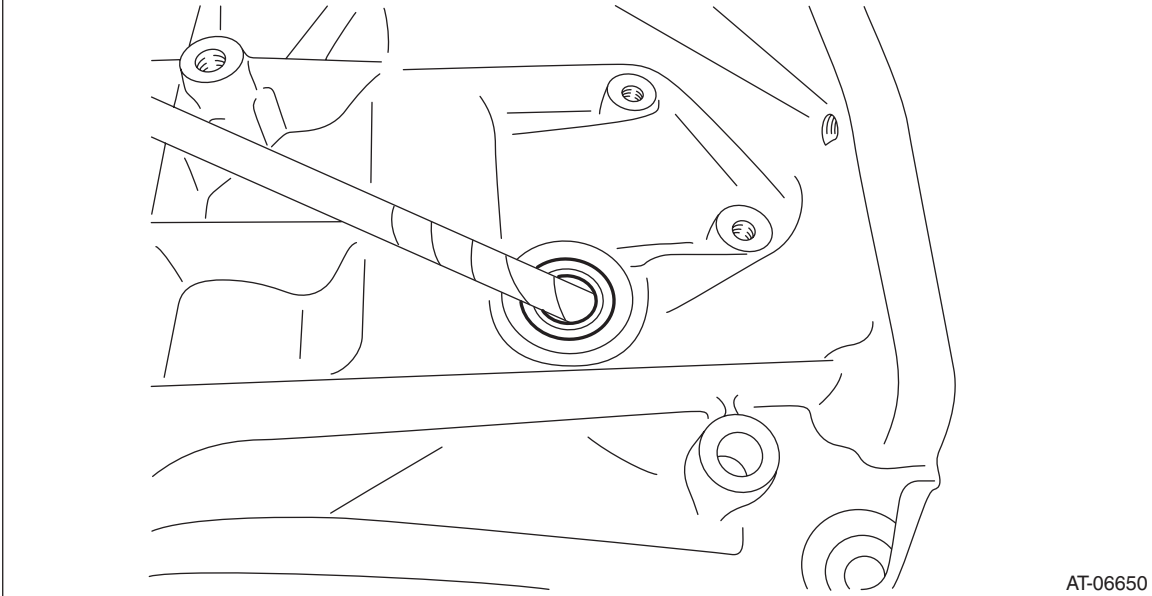

4) Remove the CVTF filter cover and gasket.

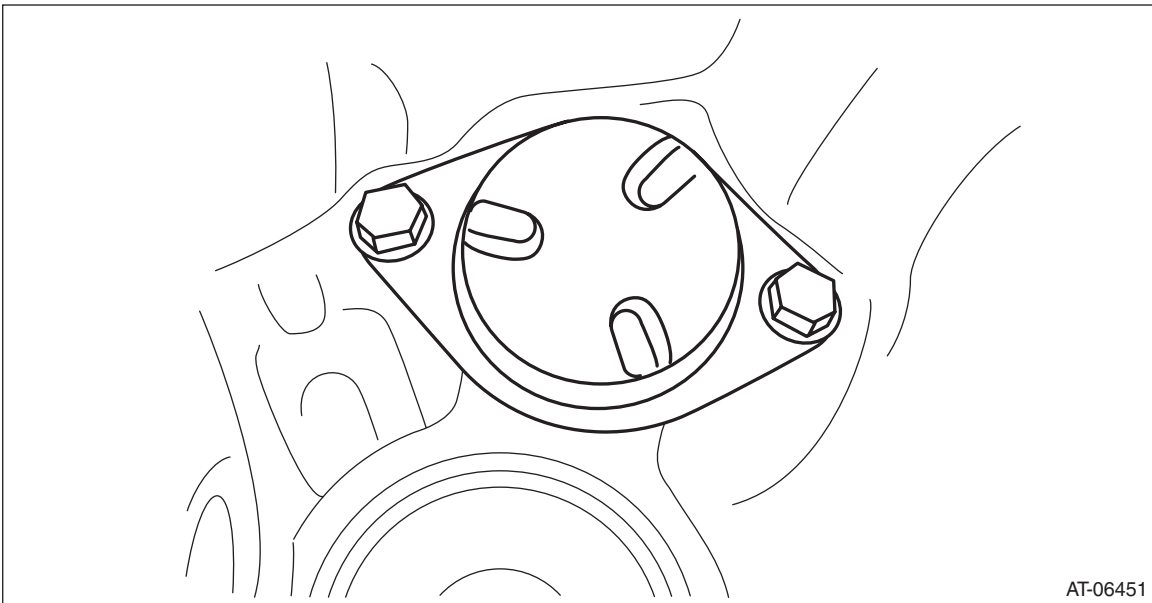

Transmission Case

CONTINUOUSLY VARIABLE TRANSMISSION

5) Remove the CVTF filter.

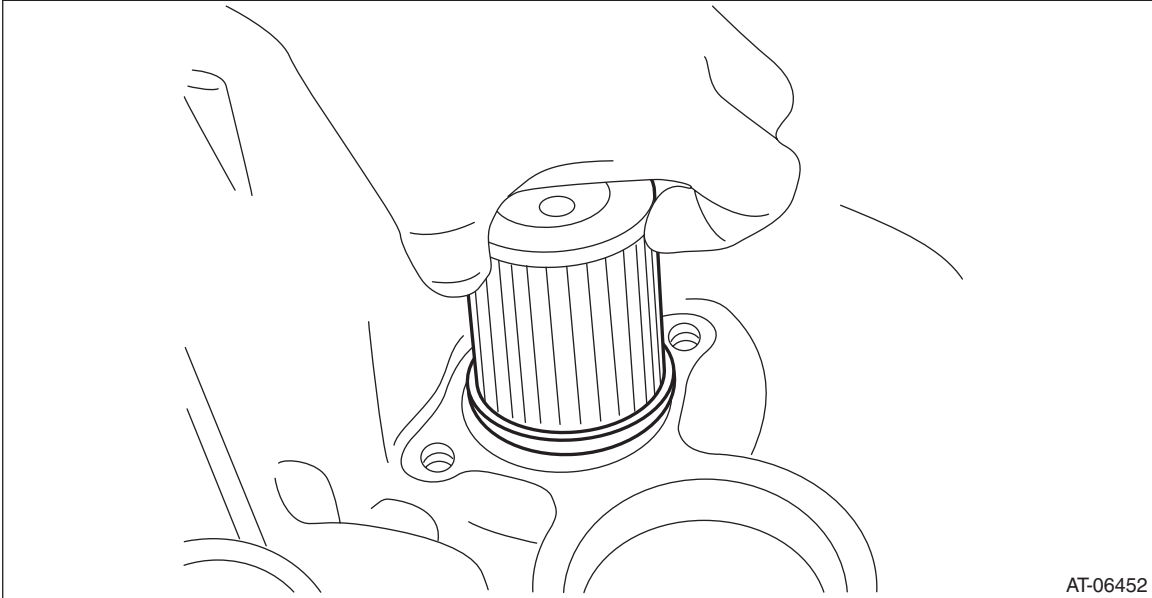

D: ASSEMBLY

1) Face the O-ring side of the CVTF filter to the transmission case side, and install the CVTF filter.

NOTE:

Apply CVTF to the O-ring of CVTF filter.

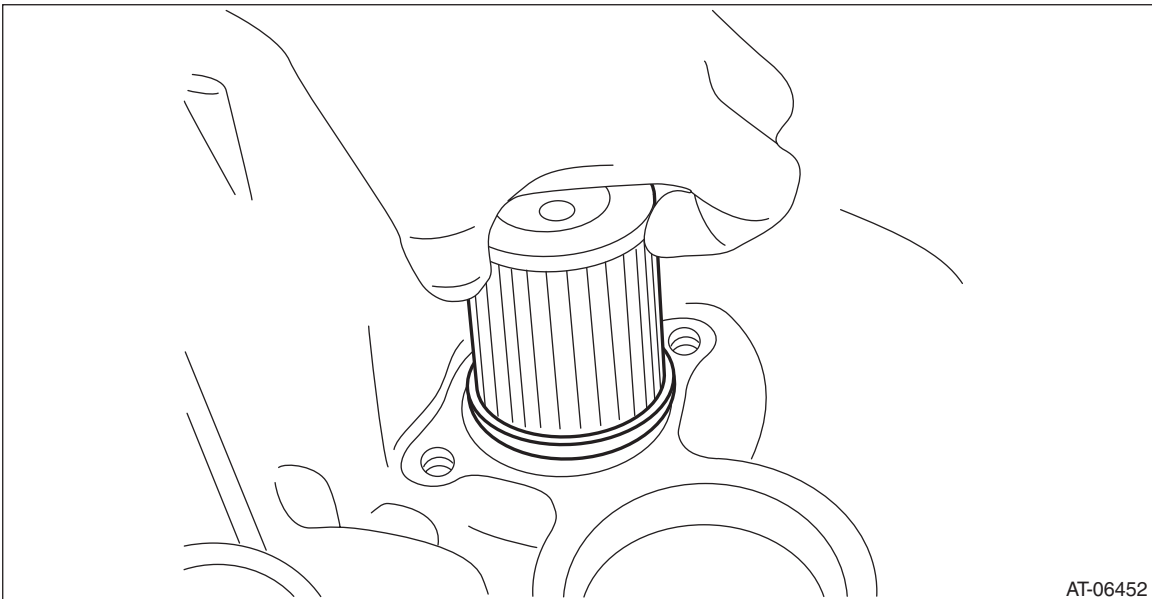

Transmission Case

CONTINUOUSLY VARIABLE TRANSMISSION

2) Install the CVTF filter cover and gasket.

NOTE:

Use a new gasket.

Tightening torque:

17 N·m (1.7 kgf·m, 12.5 ft·lb)

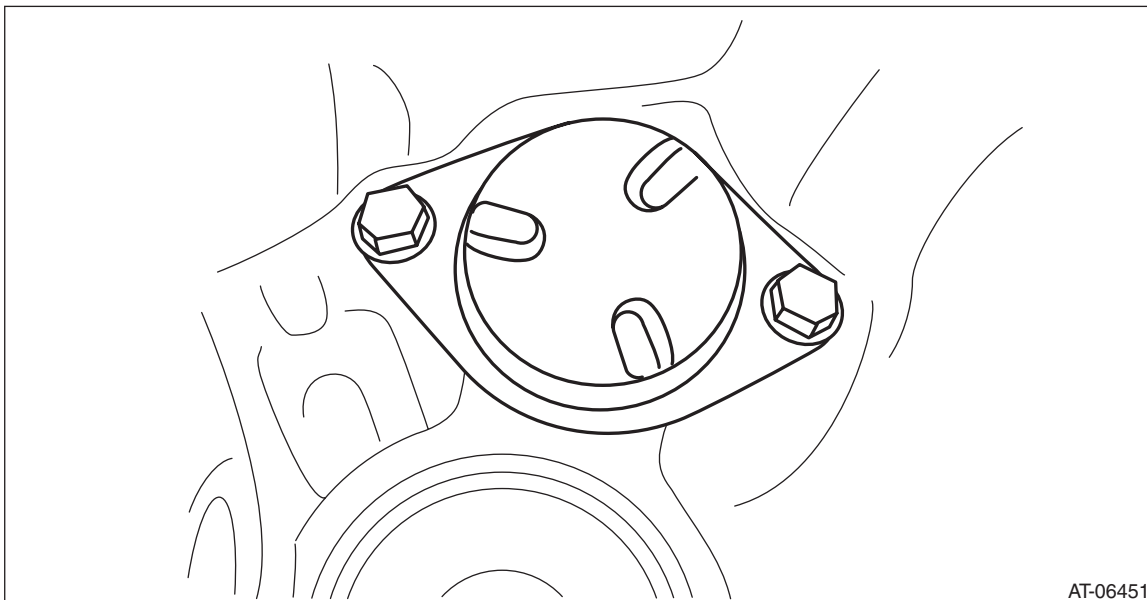

3) Using the ST, install the oil seal.

NOTE:

- Use a new oil seal.
- Apply CVTF to the oil seal lip and press-fitting surface.

ST 18657AA000 INSTALLER

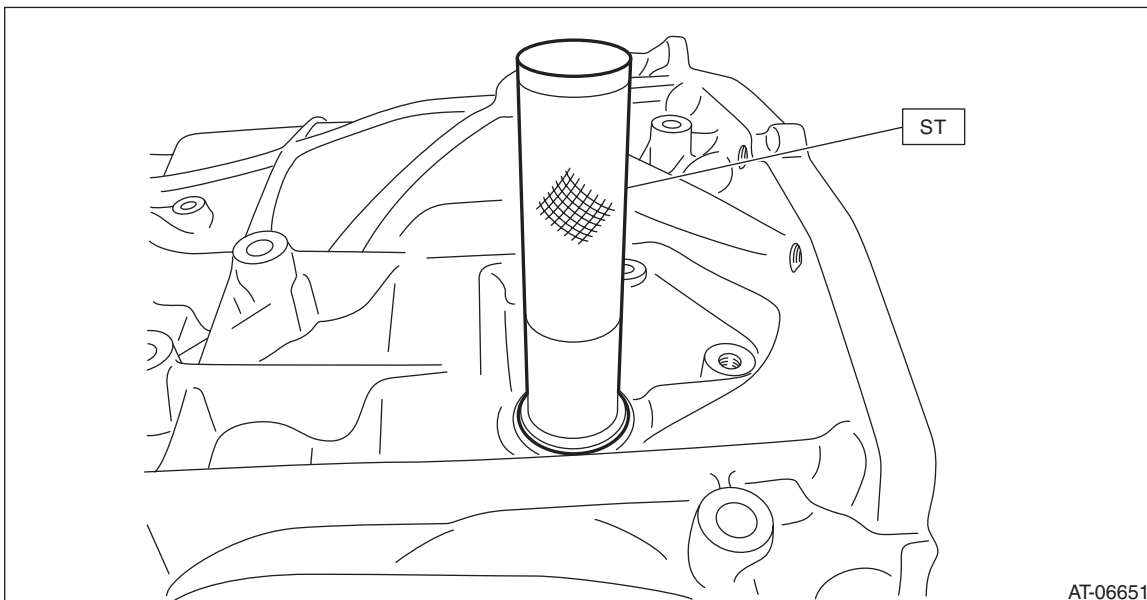

Transmission Case

CONTINUOUSLY VARIABLE TRANSMISSION

4) Install all plugs.

NOTE:

- Use new O-rings.
- Apply CVTF to the O-ring.
- For the plug (A), fill the CVTF, and then tighten the plug (A) using a new O-ring.

Tightening torque:

T1: 13 N·m (1.3 kgf-m, 9.6 ft-lb)

T2: 25 N·m (2.5 kgf-m, 18.4 ft-lb)

T3: 50 N·m (5.1 kgf-m, 36.9 ft-lb)

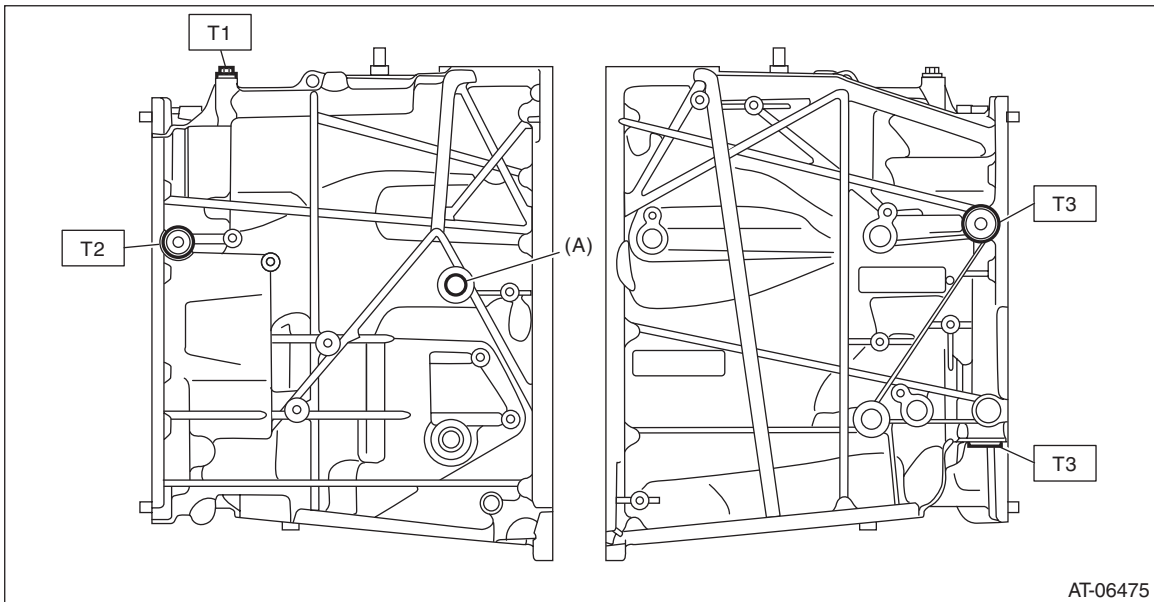

5) Install the oil stopper plate.

NOTE:

Use a new bolt.

Tightening torque:

9 N·m (0.9 kgf-m, 6.6 ft-lb)

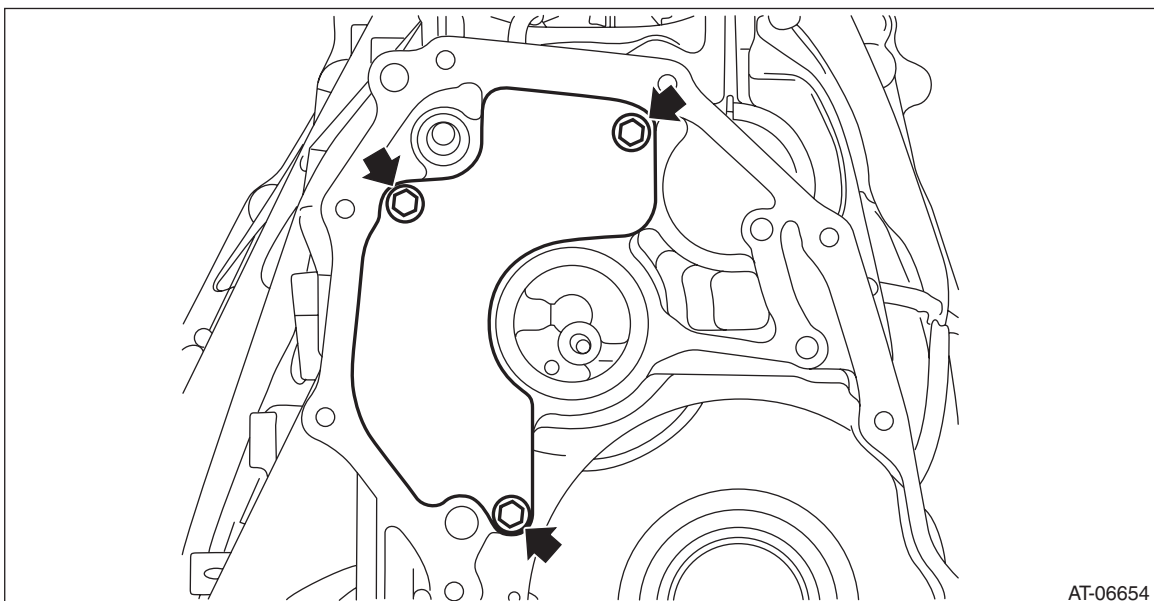

Transmission Case

CONTINUOUSLY VARIABLE TRANSMISSION

E: INSPECTION

- Check the transmission case for damage.
- Check for leakage of CVTF from the connection between converter case and transmission case.
- Check the bearing for smooth operation.
- Check the bearing for seizure or wear.

F: ADJUSTMENT

NOTE:

When replacing the transmission case with a new part, perform the following check and adjustment for the selection.

- Select the transfer driven gear shim. <Ref. to CVT-172, ADJUSTMENT, Transfer Clutch.>
- Select the transfer drive gear shim. <Ref. to CVT-185, ADJUSTMENT, Reduction Driven Gear.>
- Select the reduction drive gear shim. <Ref. to CVT-208, ADJUSTMENT, Reduction Drive Gear.>