

Primary Pulley and Secondary Pulley

CONTINUOUSLY VARIABLE TRANSMISSION

37.Primary Pulley and Secondary Pulley

A: REMOVAL

NOTE:

Always replace primary pulley and secondary pulley as an assembly because they are non-disassembled parts.

- 1) Remove the transmission assembly from the vehicle. <Ref. to CVT-56, REMOVAL, Automatic Transmission Assembly.>
- 2) Remove the air breather hose. <Ref. to CVT-148, REMOVAL, Air Breather Hose.>
- 3) Remove the control valve body. <Ref. to CVT-110, REMOVAL, Control Valve Body.>
- 4) Remove the transmission harness. <Ref. to CVT-124, REMOVAL, Transmission Harness.>
- 5) Remove the turbine speed sensor. <Ref. to CVT-97, REMOVAL, Turbine Speed Sensor.>
- 6) Remove the secondary speed sensor. <Ref. to CVT-99, REMOVAL, Secondary Speed Sensor.>
- 7) Remove the primary speed sensor. <Ref. to CVT-101, REMOVAL, Primary Speed Sensor.>
- 8) Remove the inhibitor switch. <Ref. to CVT-93, REMOVAL, Inhibitor Switch.>
- 9) Remove the extension case. <Ref. to CVT-156, REMOVAL, Extension Case.>
- 10) Remove the transfer clutch assembly. <Ref. to CVT-160, REMOVAL, Transfer Clutch.>
- 11) Remove the transfer driven gear assembly. <Ref. to CVT-174, REMOVAL, Transfer Driven Gear.>
- 12) Remove the parking pawl. <Ref. to CVT-177, REMOVAL, Parking Pawl.>
- 13) Remove the reduction driven gear assembly. <Ref. to CVT-179, REMOVAL, Reduction Driven Gear.>
- 14) Remove the oil pan and oil strainer. <Ref. to CVT-106, REMOVAL, Oil Pan and Strainer.>
- 15) Remove the transmission control device. <Ref. to CVT-187, REMOVAL, Transmission Control Device.>
- 16) Remove the transmission case. <Ref. to CVT-193, REMOVAL, Transmission Case.>
- 17) Remove the reduction drive gear. <Ref. to CVT-206, REMOVAL, Reduction Drive Gear.>
- 18) Set the ST to secondary pulley, expand the V groove of pulley, and then completely loosen the variator chain.

ST 18769AA010 EXPANDER PULLEY

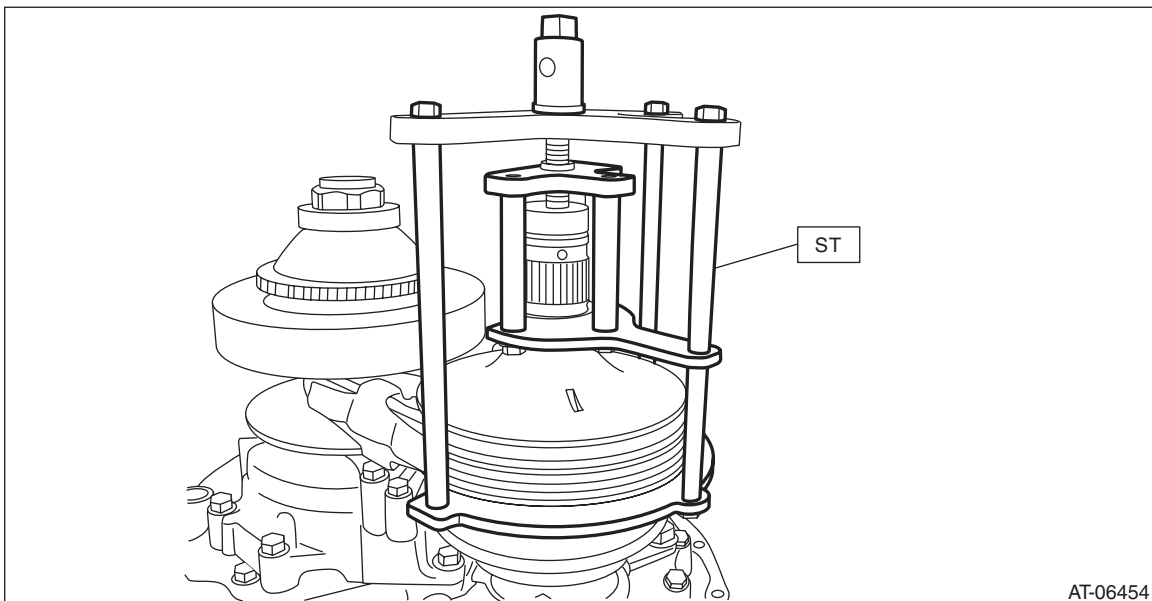

AT-06454

Primary Pulley and Secondary Pulley

CONTINUOUSLY VARIABLE TRANSMISSION

19) Remove the chain guide.

- (1) Remove the chain guide from lubrication pipe.
- (2) Detach the four claws to remove the chain guide.

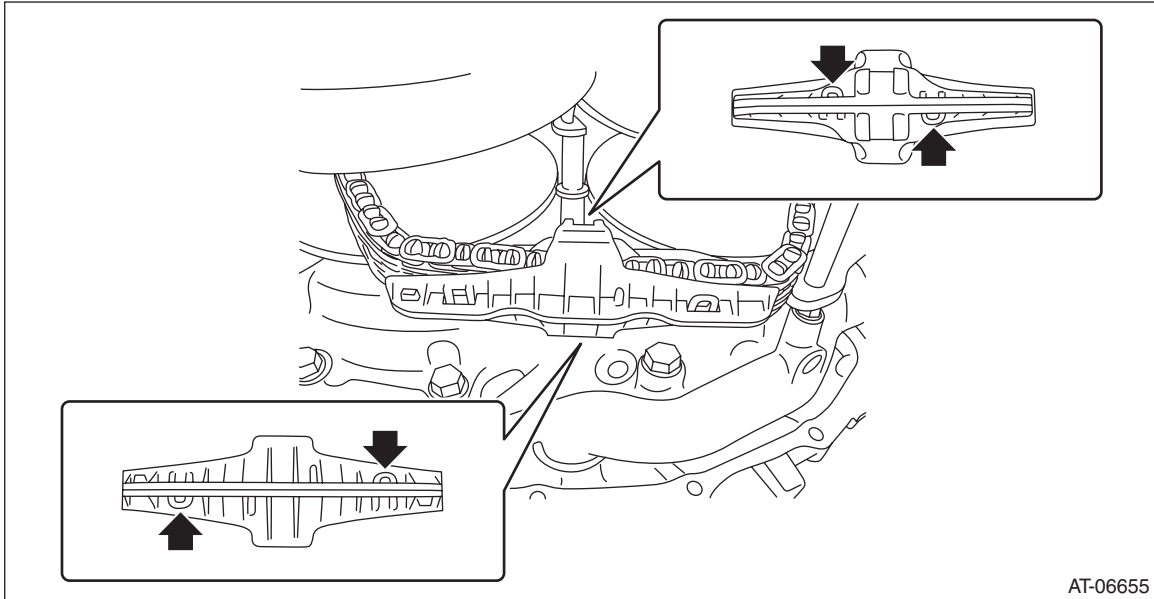

(3) Remove the lubrication pipe.

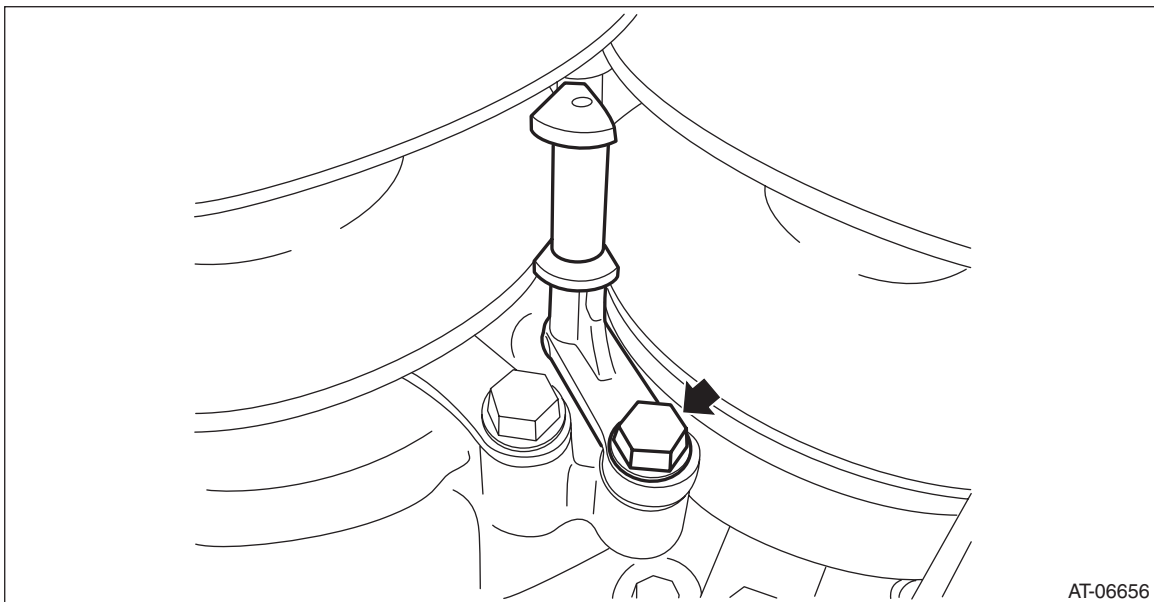

Primary Pulley and Secondary Pulley

CONTINUOUSLY VARIABLE TRANSMISSION

(4) Remove the support rod mounting bolts.

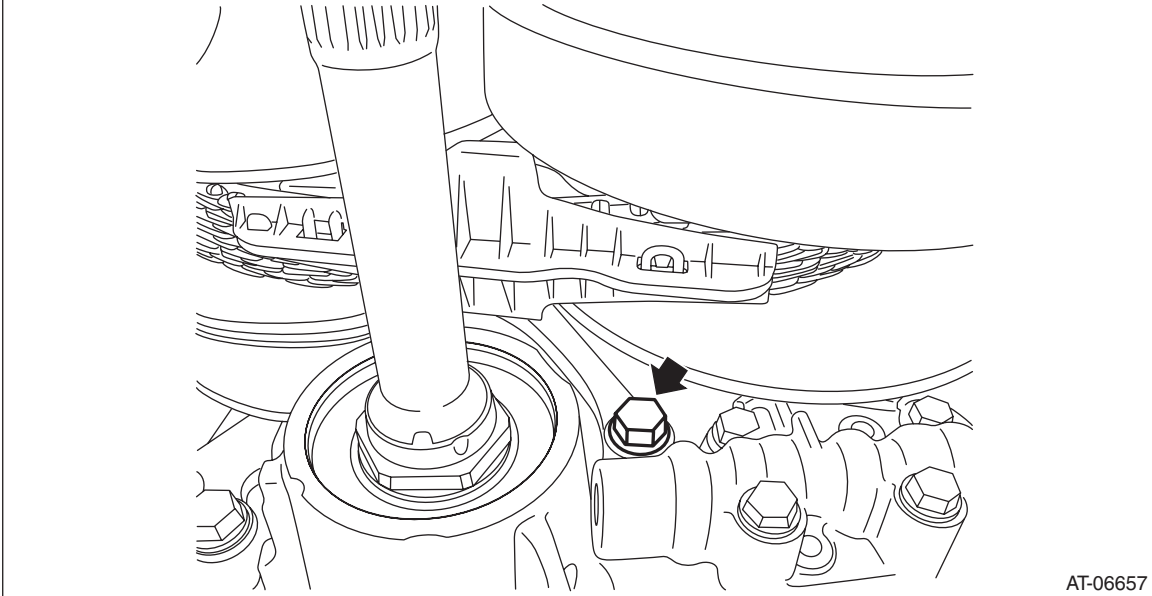

(5) Raise the support rod to remove the chain guide.

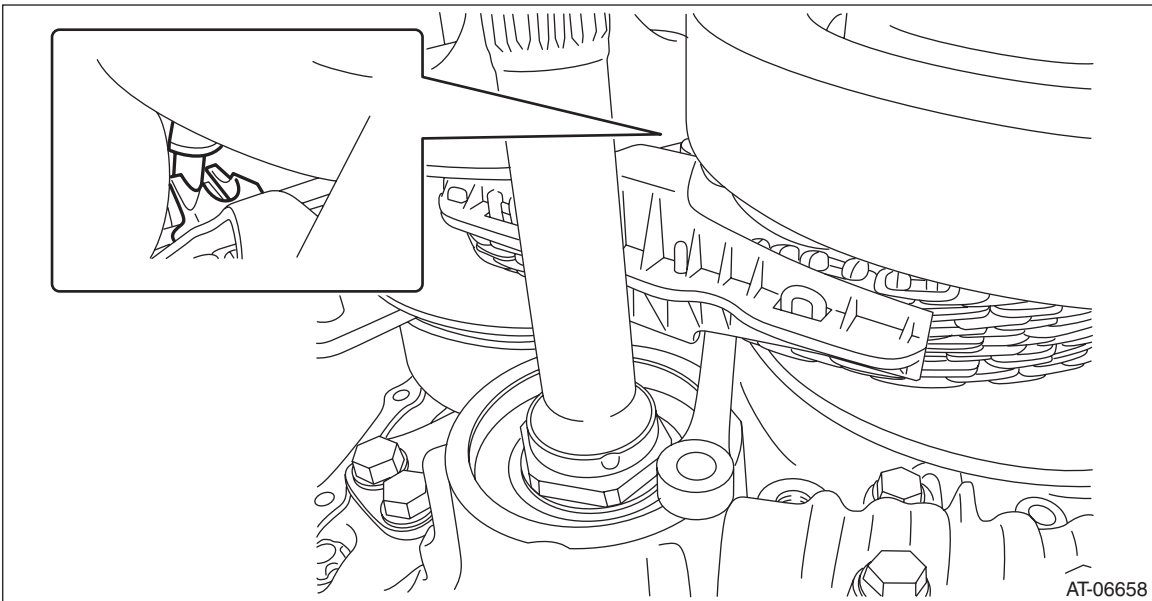

Primary Pulley and Secondary Pulley

CONTINUOUSLY VARIABLE TRANSMISSION

(6) Move the chain guide to the secondary pulley side.

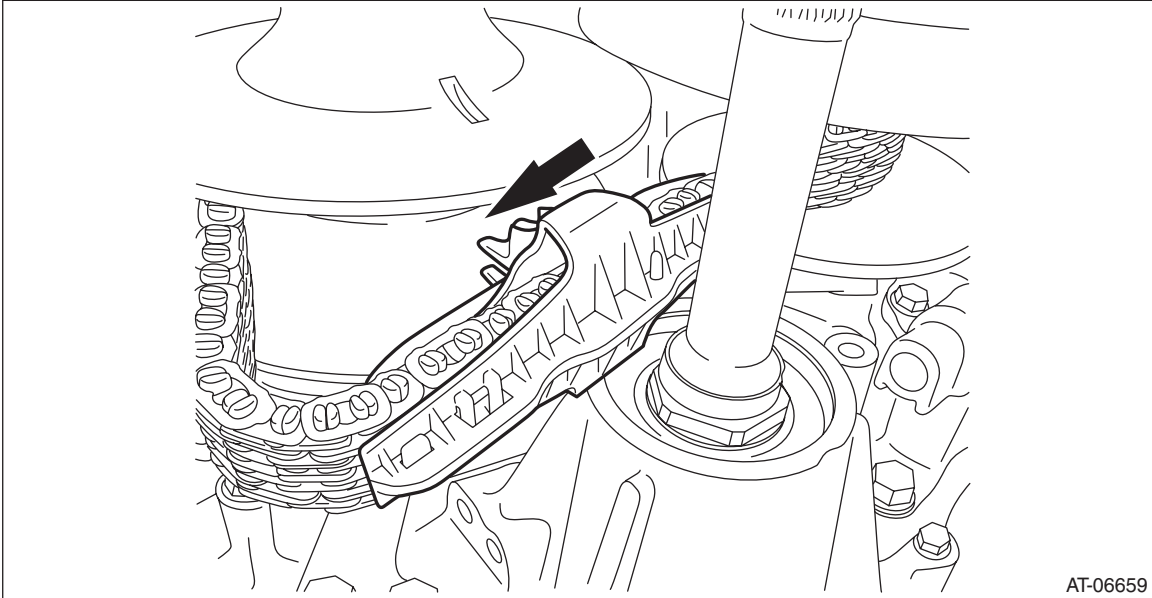

(7) Detach the four claws to remove the chain guide.

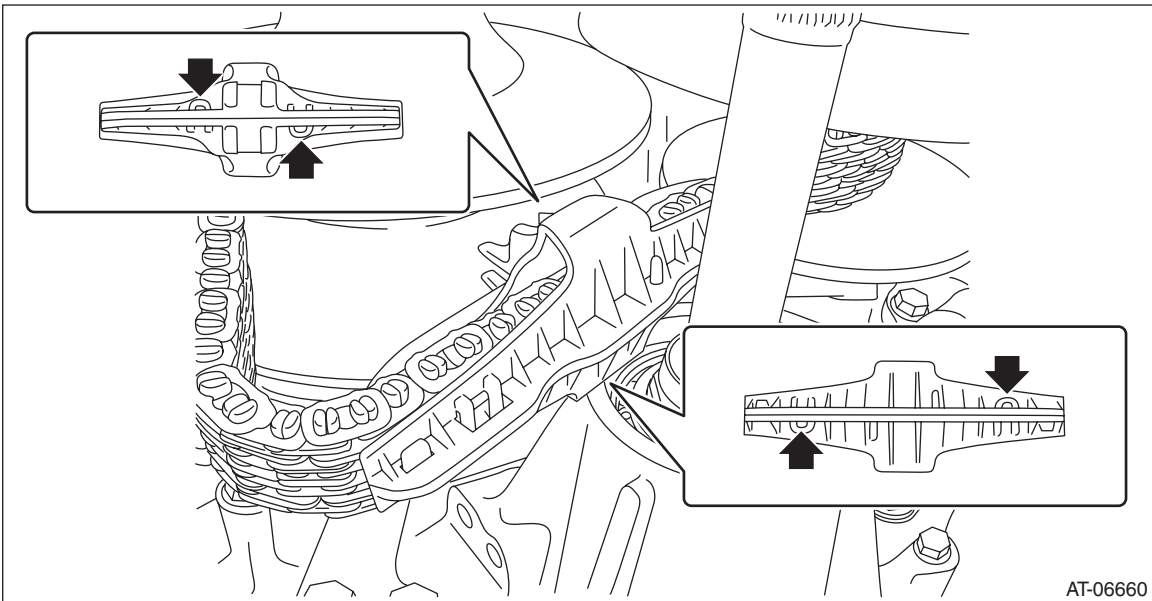

Primary Pulley and Secondary Pulley

CONTINUOUSLY VARIABLE TRANSMISSION

(8) Remove the support rod.

CAUTION:

Protect the both pulleys and variator chain from scratching.

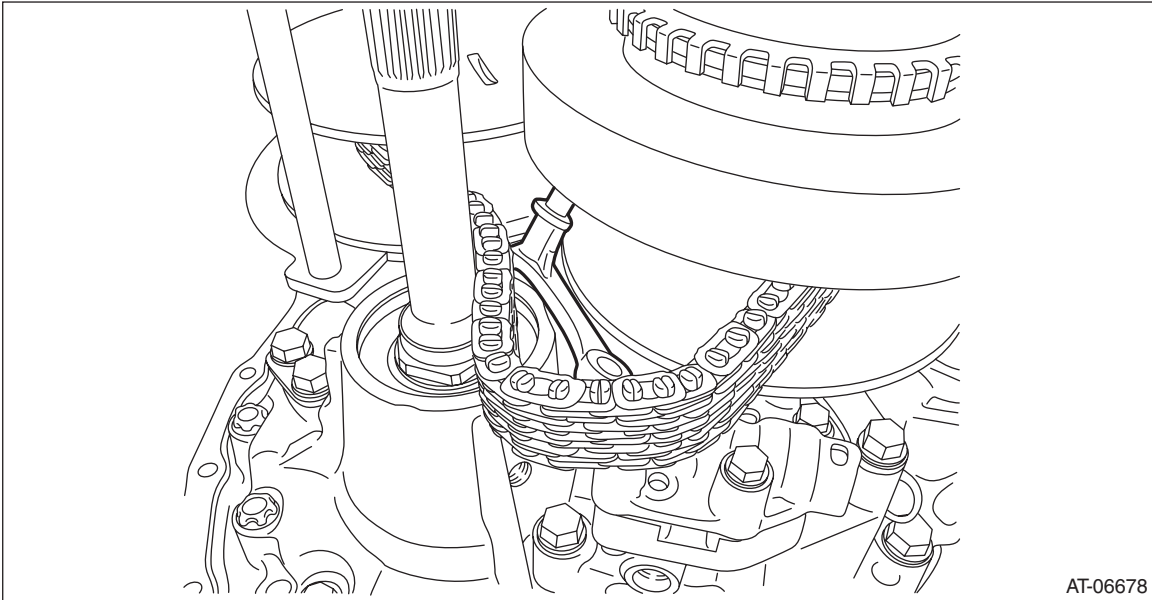

20) Remove the primary pulley mounting bolt.

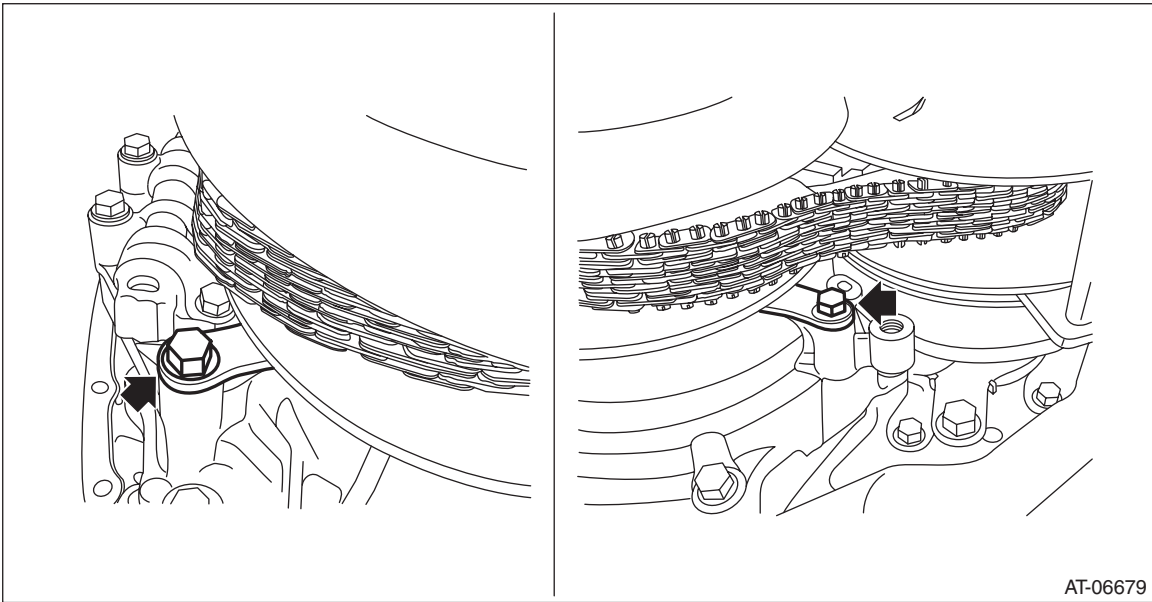

Primary Pulley and Secondary Pulley

CONTINUOUSLY VARIABLE TRANSMISSION

21) Remove the primary pulley from the reverse brake housing and intersect the V groove of secondary pulley and the V groove of primary pulley. Remove the variator chain from primary pulley, and remove the primary pulley.

CAUTION:

Cover the V grooves of secondary pulley and primary pulley with cloth to protect the both pulleys and variator chain from scratching.

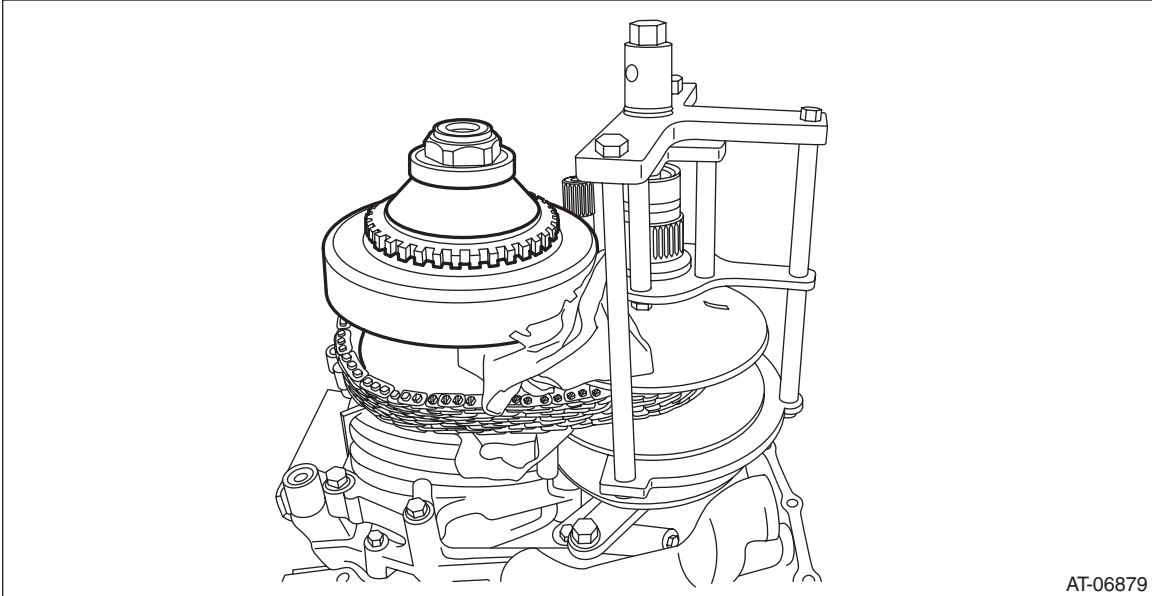

22) Remove the ST (EXPANDER PULLEY) from the secondary pulley.

23) Remove the variator chain from secondary pulley.

24) Remove the secondary pulley mounting bolts, and remove the secondary pulley.

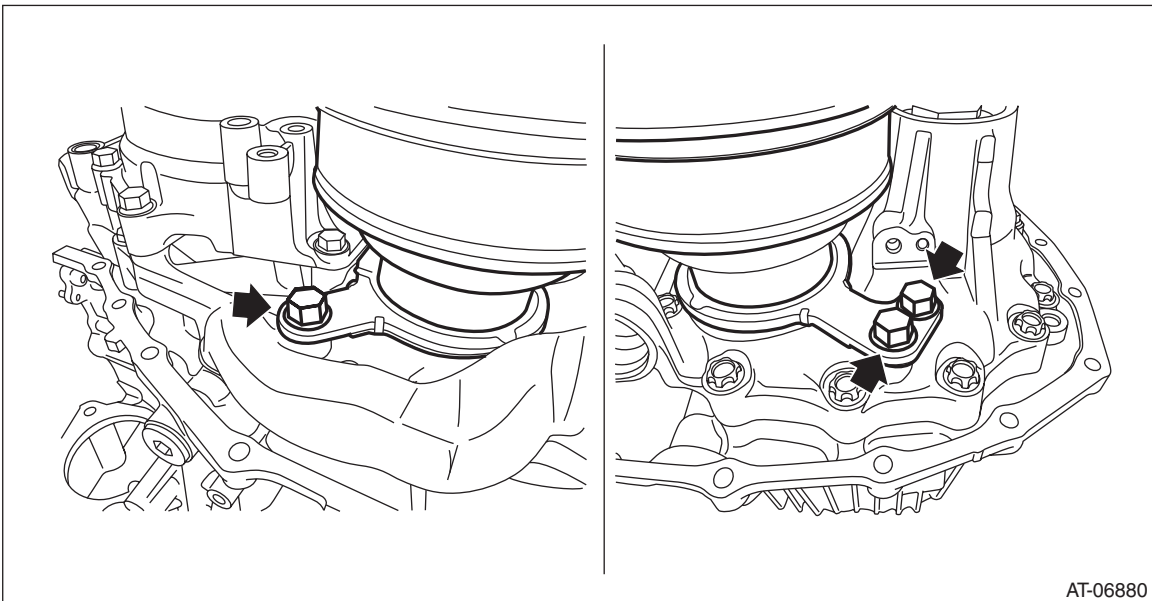

Primary Pulley and Secondary Pulley

CONTINUOUSLY VARIABLE TRANSMISSION

25) Remove the seal ring from drive pinion retainer.

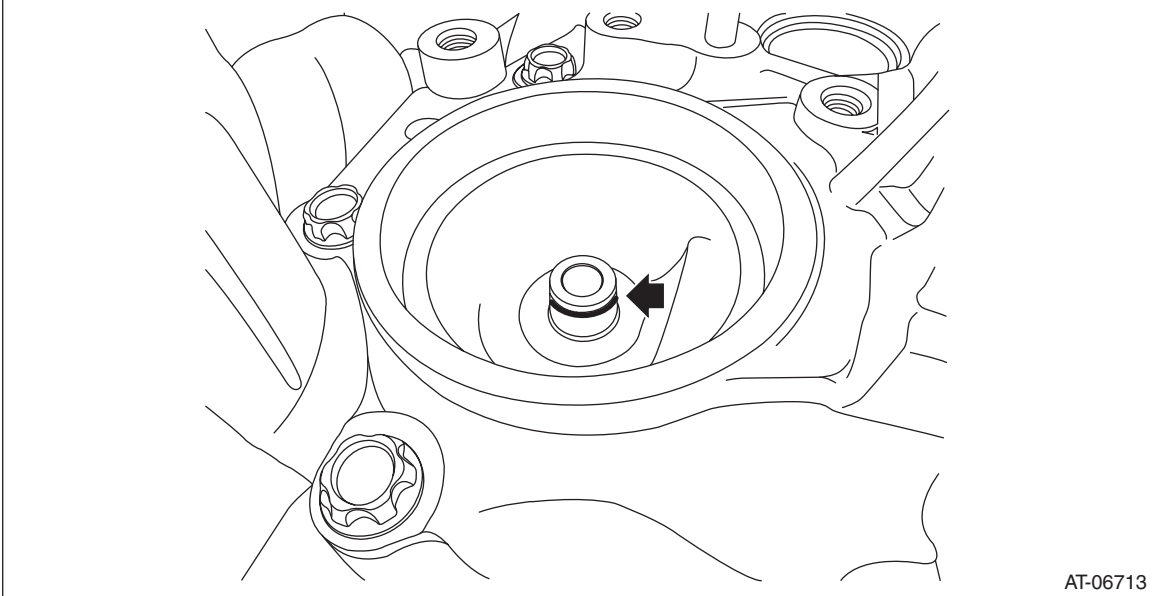

26) Remove the seal ring from the input shaft.

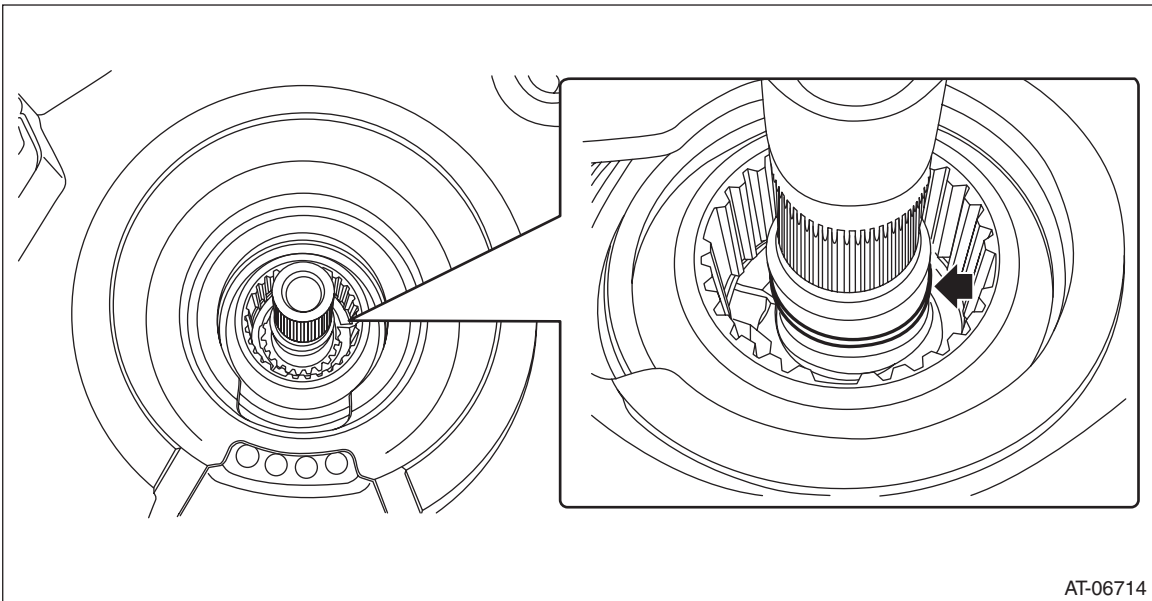

Primary Pulley and Secondary Pulley

CONTINUOUSLY VARIABLE TRANSMISSION

B: INSTALLATION

- 1) Select shims for pulley alignment. <Ref. to CVT-225, ADJUSTMENT, Primary Pulley and Secondary Pulley.>
- 2) Install the seal ring to the input shaft.

NOTE:

- Use a new seal ring.
- When installing the seal ring, do not expand the seal ring too much.
- Apply CVTF to the seal rings.

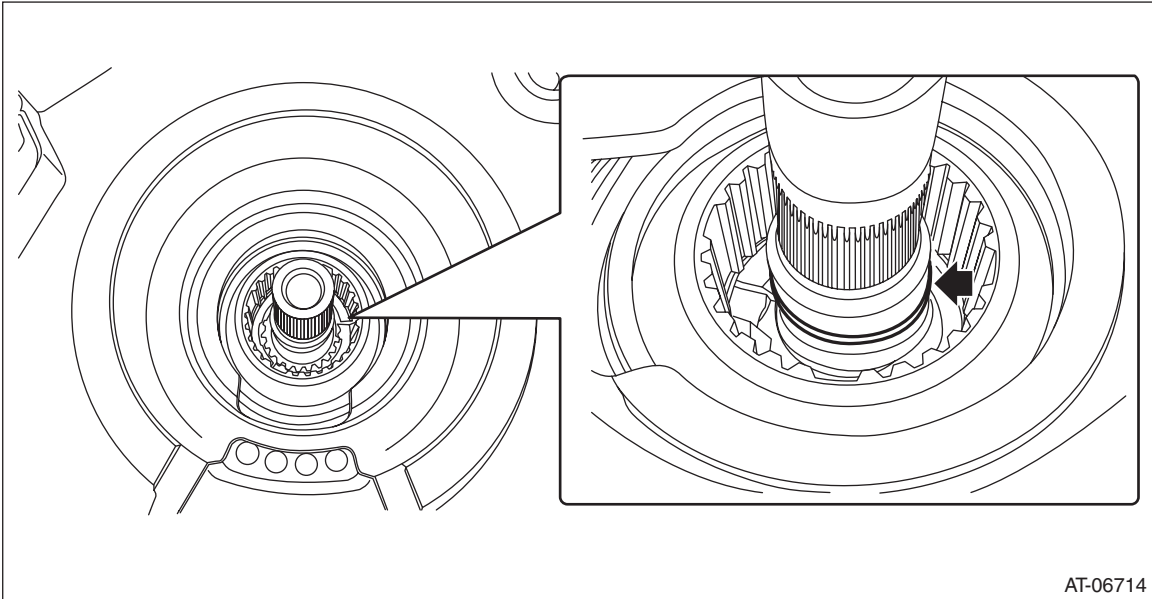

AT-06714

- 3) Install the seal ring to drive pinion retainer.

NOTE:

- Use a new seal ring.
- Apply CVTF to the seal rings.

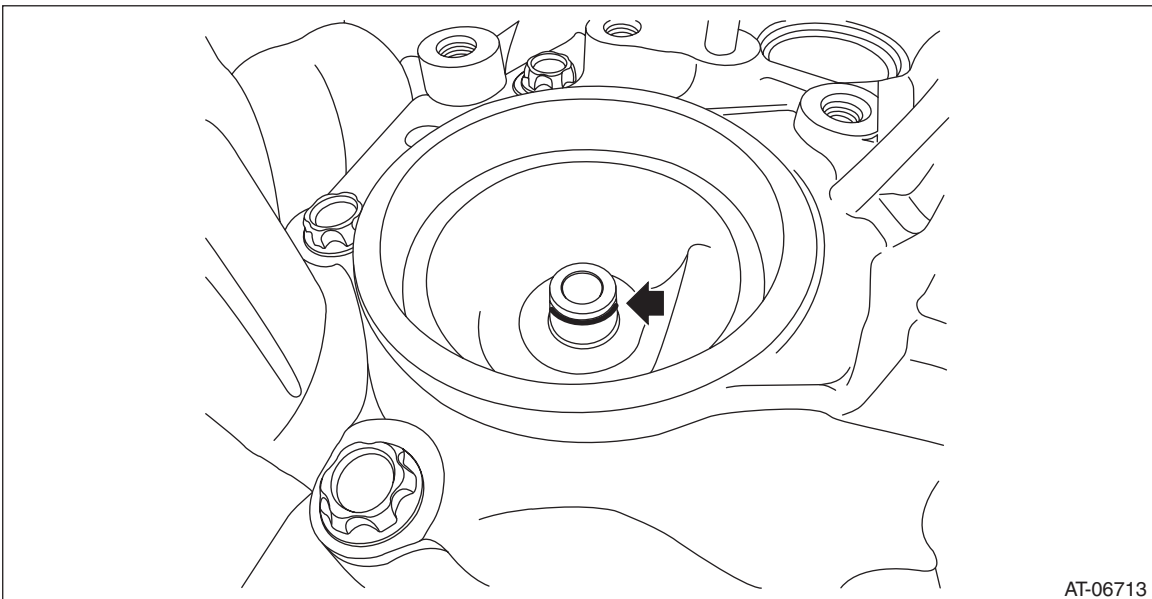

AT-06713

- 4) Install the selected shims to the primary pulley bearing catch surface.

Primary Pulley and Secondary Pulley

CONTINUOUSLY VARIABLE TRANSMISSION

5) Install the secondary pulley to the drive pinion retainer.

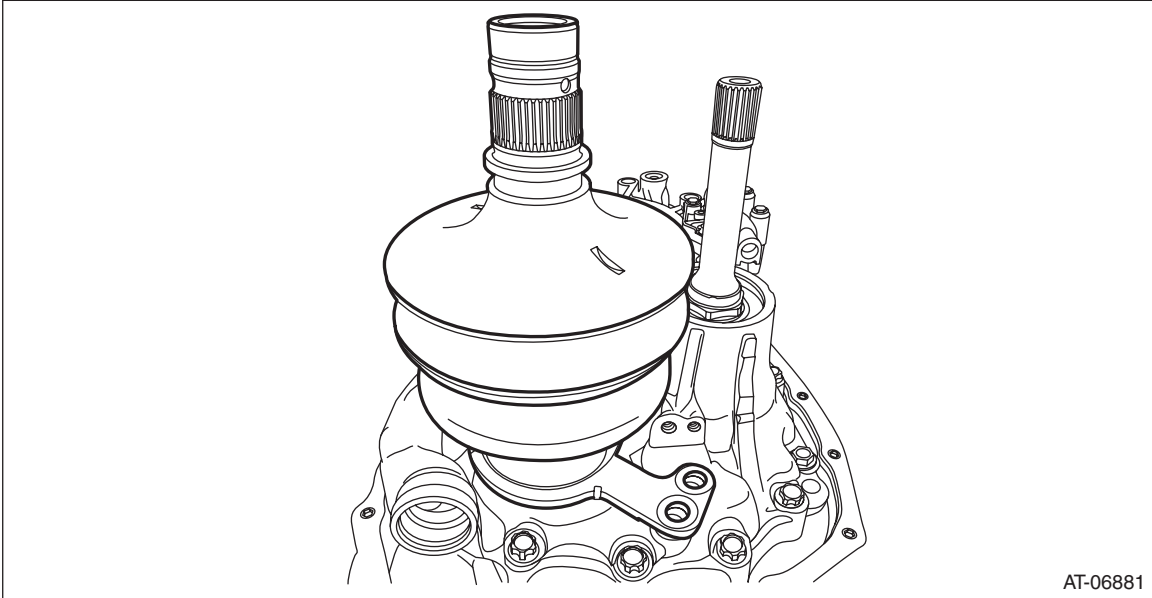

6) Install and tighten the secondary pulley securing bolts.

(1) Tighten the three bolts until the seating surfaces contact the bearing retainer.

NOTE:

- Be careful not to tilt the bearing retainer of the secondary pulley.
- Apply CVTF to the bolt.

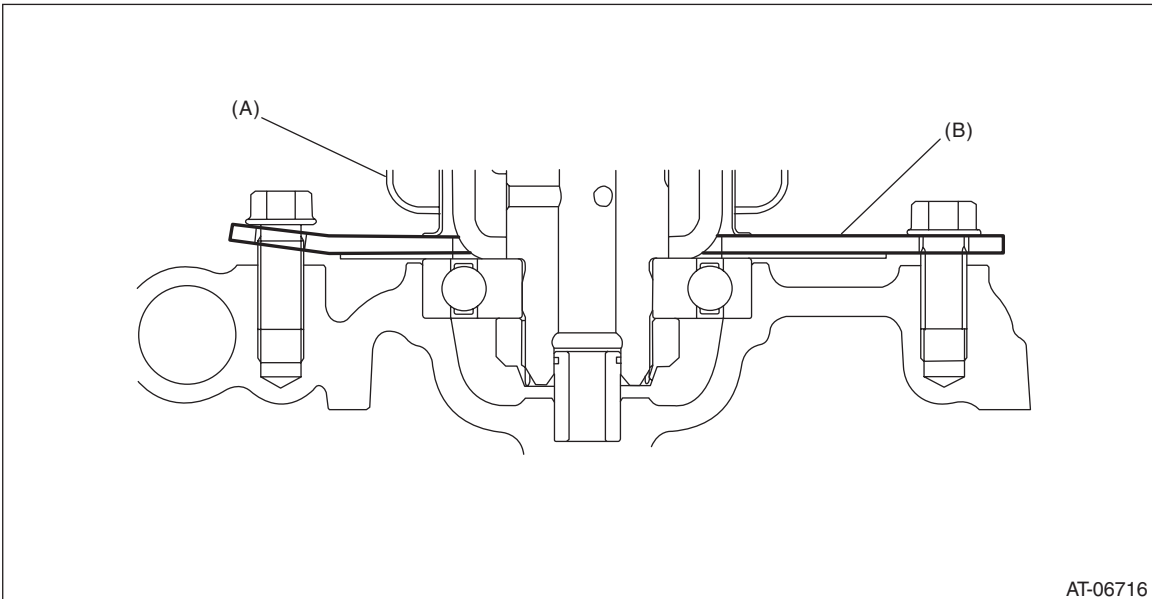

(A) Secondary pulley

(B) Bearing retainer

Primary Pulley and Secondary Pulley

CONTINUOUSLY VARIABLE TRANSMISSION

(2) Tighten the bolts in the order of (A) → (B) → (C) → (B).

Tightening torque:

67.5 N·m (6.9 kgf·m, 49.8 ft·lb)

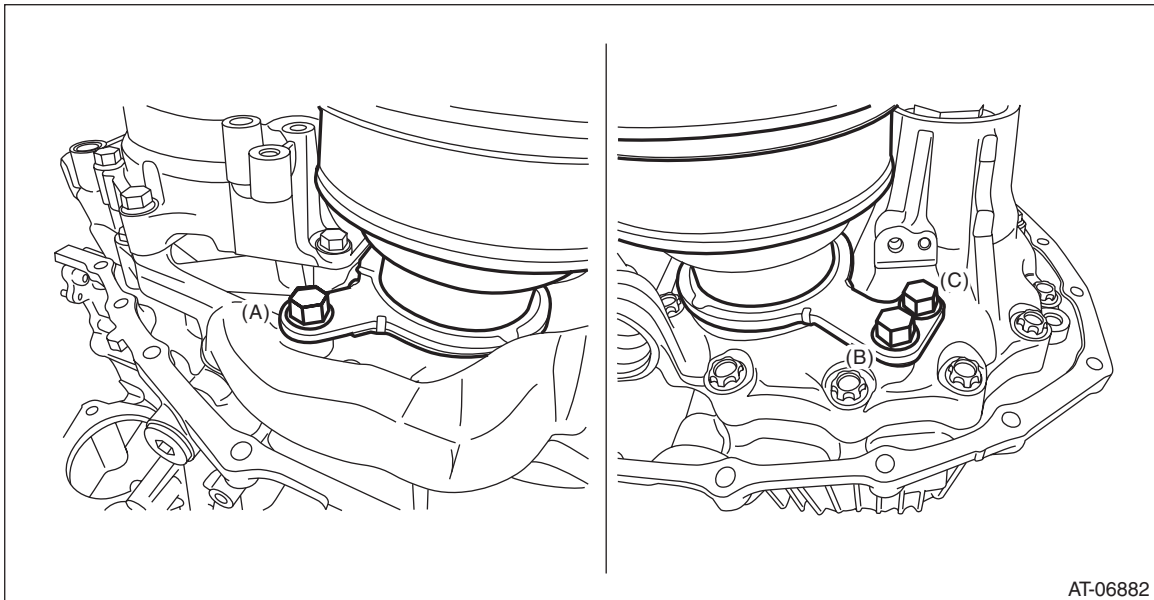

AT-06882

7) Place the variator chain on the V groove of the secondary pulley, and set the ST.
ST 18769AA010 EXPANDER PULLEY

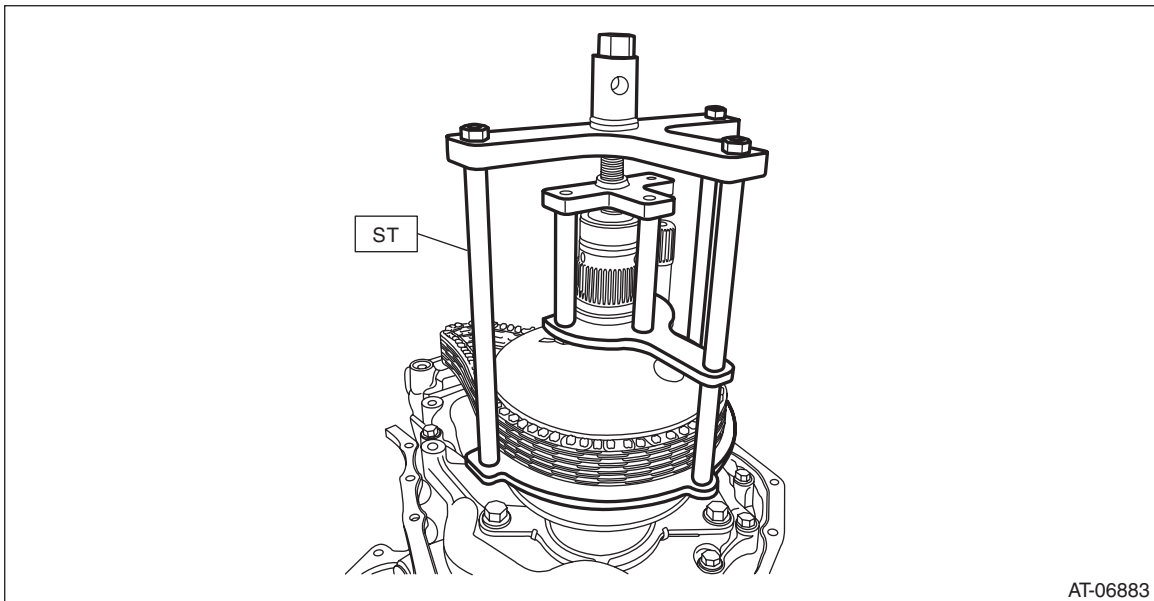

AT-06883

8) Expand the V groove of the secondary pulley.

Primary Pulley and Secondary Pulley

CONTINUOUSLY VARIABLE TRANSMISSION

9) Install the primary pulley to the reverse brake housing together with the variator chain.

CAUTION:

Cover the V grooves of primary pulley and secondary pulley with cloth to protect the both pulleys and variator chain from scratching.

(1) Intersect the V groove of primary pulley and the V groove of secondary pulley and install the secondary pulley while placing the variator chain on secondary pulley.

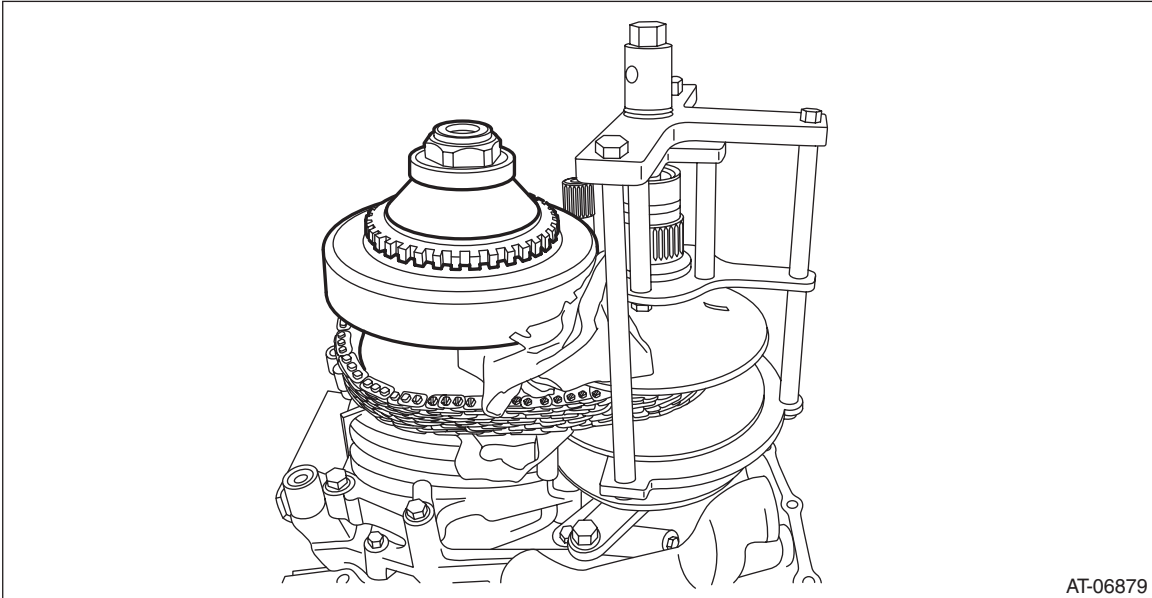

(2) Install the primary pulley to the reverse brake housing so that the bolt hole of primary bearing retainer and the bolt hole of reverse brake housing are aligned.

10) Install the primary pulley bolt.

Tightening torque:

21 N·m (2.1 kgf·m, 24.3 ft·lb)

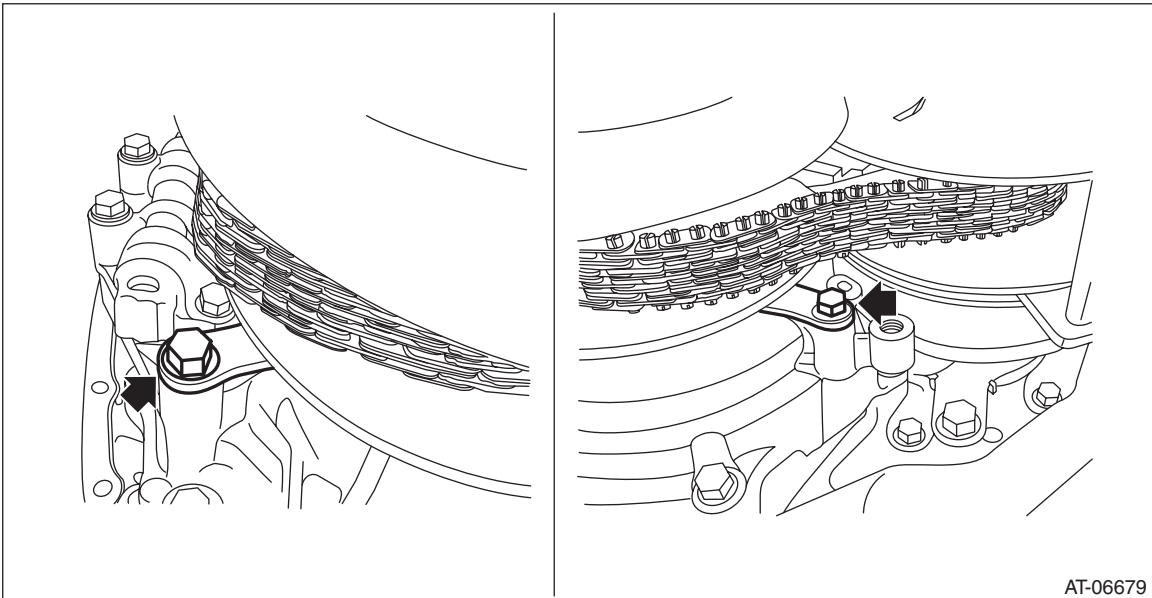

Primary Pulley and Secondary Pulley

CONTINUOUSLY VARIABLE TRANSMISSION

11) Install the chain guide.

(1) Place the support rod inside of the variator chain.

CAUTION:

Protect the both pulleys and variator chain from scratching.

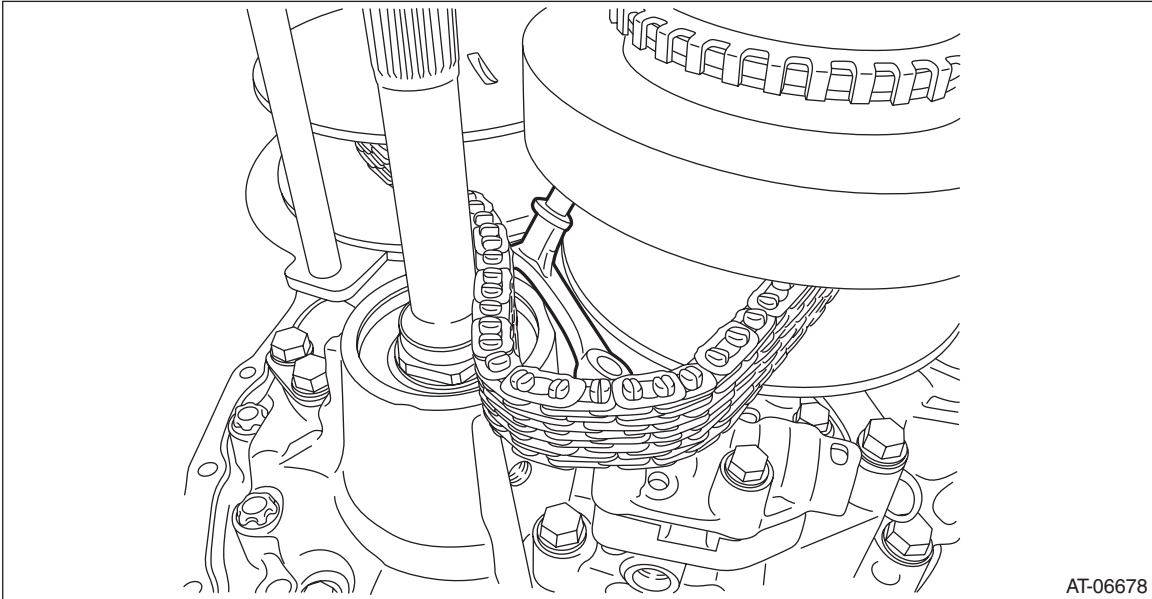

(2) Install the chain guide to the variator chain.

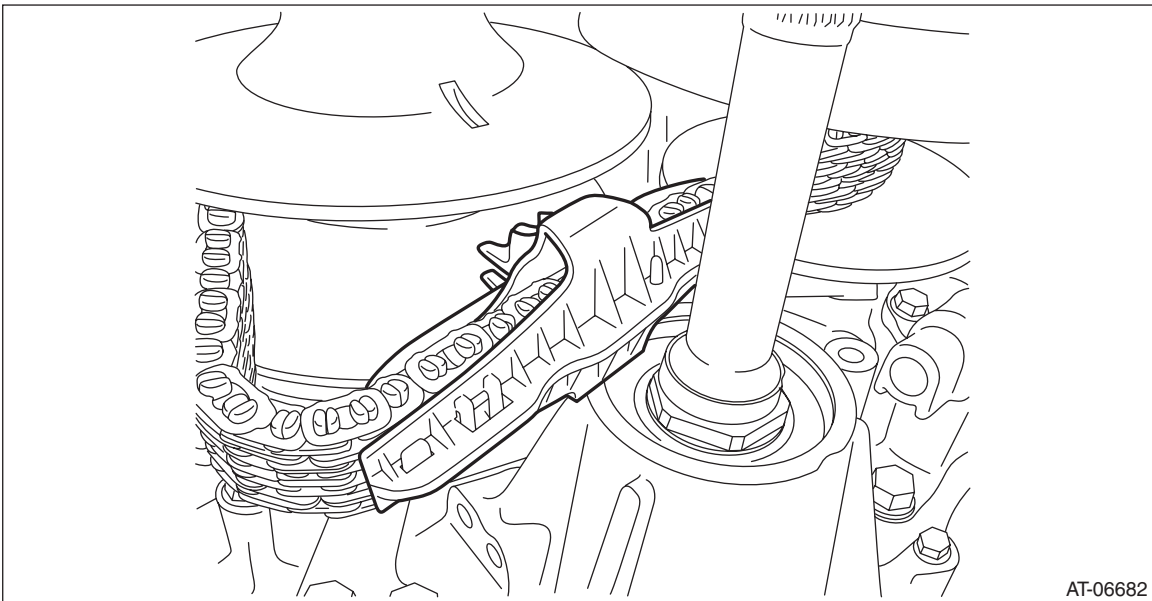

(3) Move the chain guide to the support rod side.

Primary Pulley and Secondary Pulley

CONTINUOUSLY VARIABLE TRANSMISSION

(4) While holding the support rod, press the chain guide so that the support rod runs through between the protrusions of chain guide and install the chain guide to the support rod.

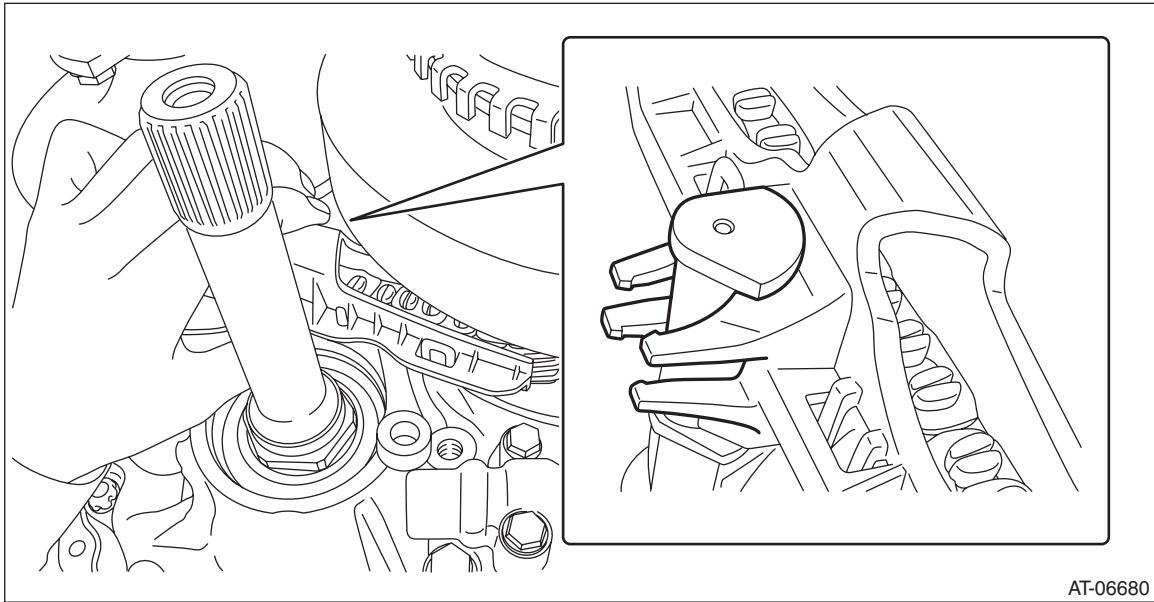

(5) Install the support rod.

Tightening torque:

21 N·m (2.1 kgf·m, 15.5 ft·lb)

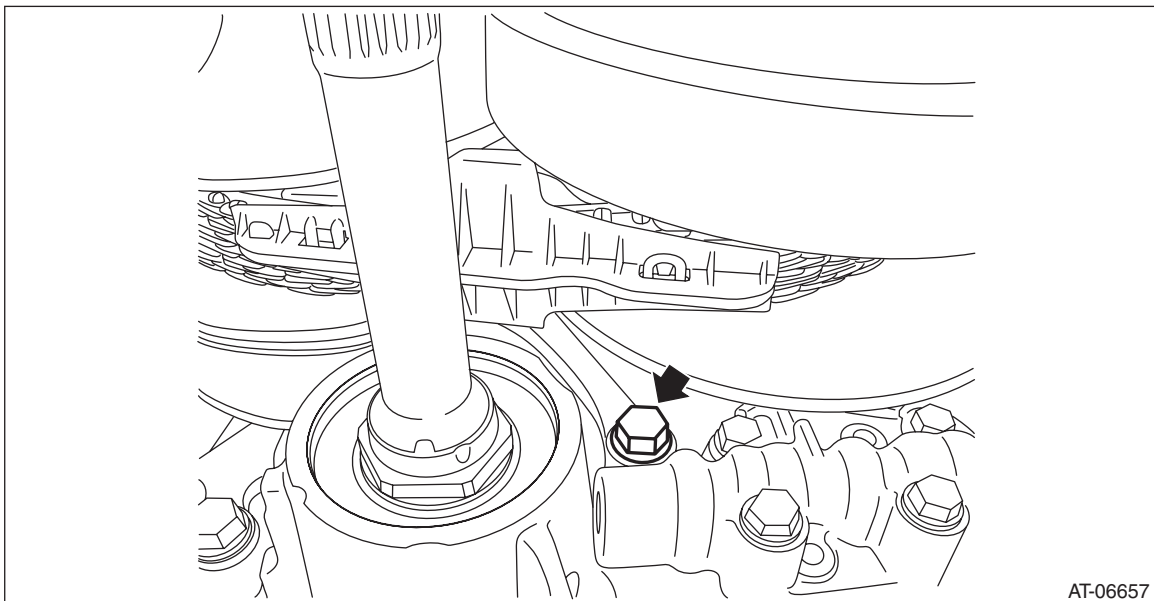

Primary Pulley and Secondary Pulley

CONTINUOUSLY VARIABLE TRANSMISSION

(6) Install the lubrication pipe.

Tightening torque:

21 N·m (2.1 kgf-m, 15.5 ft-lb)

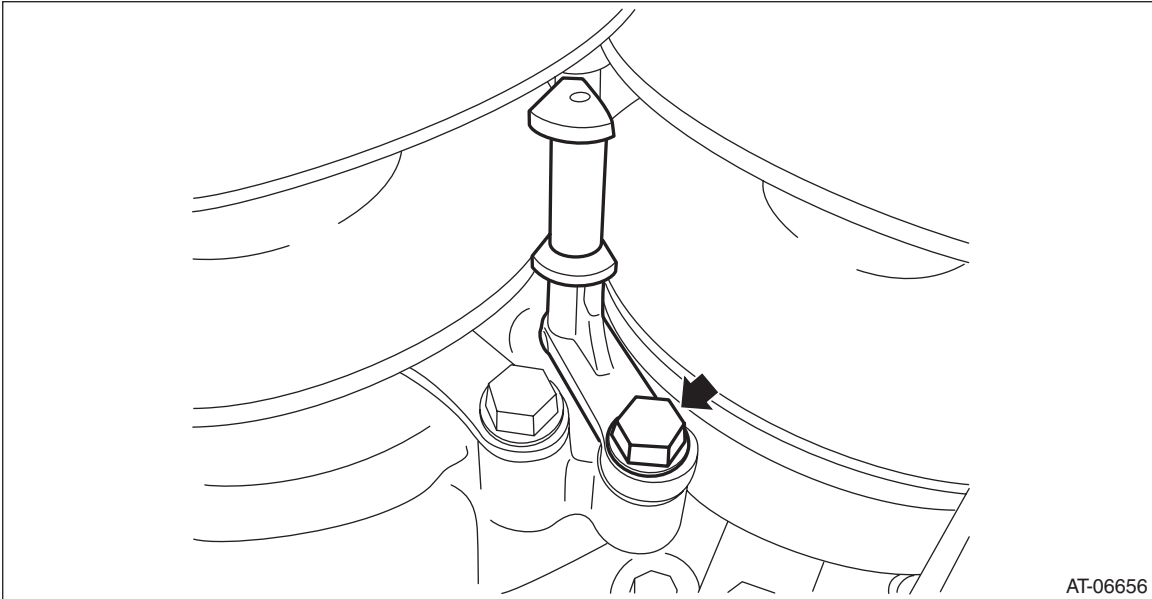

AT-06656

(7) Install the chain guide so that the lubrication pipe runs through between the protrusions of each chain guide. Then remove the ST (PULLEY EXPANDER).

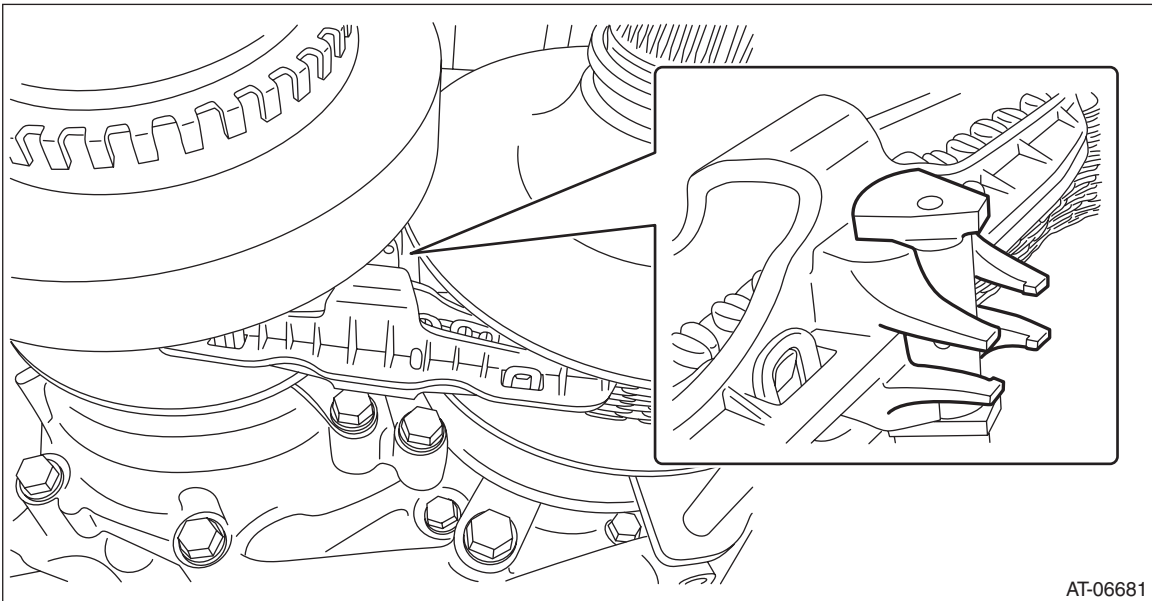

AT-06681

Primary Pulley and Secondary Pulley

CONTINUOUSLY VARIABLE TRANSMISSION

- 12) Install the reduction drive gear. <Ref. to CVT-207, INSTALLATION, Reduction Drive Gear.>
- 13) Select the reduction drive gear shim. <Ref. to CVT-208, ADJUSTMENT, Reduction Drive Gear.>
- 14) Install the transmission case. <Ref. to CVT-196, INSTALLATION, Transmission Case.>
- 15) Install the transmission control device. <Ref. to CVT-190, INSTALLATION, Transmission Control Device.>
- 16) Install the oil strainer and oil pan. <Ref. to CVT-107, INSTALLATION, Oil Pan and Strainer.>
- 17) Install the reduction driven gear assembly. <Ref. to CVT-179, INSTALLATION, Reduction Driven Gear.>
- 18) Install the transfer driven gear assembly. <Ref. to CVT-175, INSTALLATION, Transfer Driven Gear.>
- 19) Install the transfer clutch assembly. <Ref. to CVT-162, INSTALLATION, Transfer Clutch.>
- 20) Install the parking pawl. <Ref. to CVT-178, INSTALLATION, Parking Pawl.>
- 21) Install the extension case. <Ref. to CVT-157, INSTALLATION, Extension Case.>
- 22) Install the inhibitor switch. <Ref. to CVT-95, INSTALLATION, Inhibitor Switch.>
- 23) Install the secondary speed sensor. <Ref. to CVT-99, INSTALLATION, Secondary Speed Sensor.>
- 24) Install the primary speed sensor. <Ref. to CVT-102, INSTALLATION, Primary Speed Sensor.>
- 25) Install the turbine speed sensor. <Ref. to CVT-97, INSTALLATION, Turbine Speed Sensor.>
- 26) Install the transmission harness. <Ref. to CVT-130, INSTALLATION, Transmission Harness.>
- 27) Install the control valve body. <Ref. to CVT-116, INSTALLATION, Control Valve Body.>
- 28) Install the air breather hose. <Ref. to CVT-149, INSTALLATION, Air Breather Hose.>
- 29) Install the transmission assembly to the vehicle. <Ref. to CVT-67, INSTALLATION, Automatic Transmission Assembly.>

C: INSPECTION

- Check the surface of primary and secondary pulley cones for damage or wear.
- Check the primary and secondary pulley for damage.
- Check the bearing for seizure or wear.
- Apply CVTF to bearing and rotate the bearing to check for noise or dragging etc.

Primary Pulley and Secondary Pulley

CONTINUOUSLY VARIABLE TRANSMISSION

D: ADJUSTMENT

1. PROCEDURE IN REPLACEMENT OF PRIMARY AND SECONDARY PULLEY, OR IN REPLACEMENT OF PRIMARY PULLEY, SECONDARY PULLEY AND VARIATOR CHAIN

1) Measure the depth "Lp" from the ST upper face to the primary pulley bearing catch surface at several points and calculate the average.

ST 499575400 GAUGE

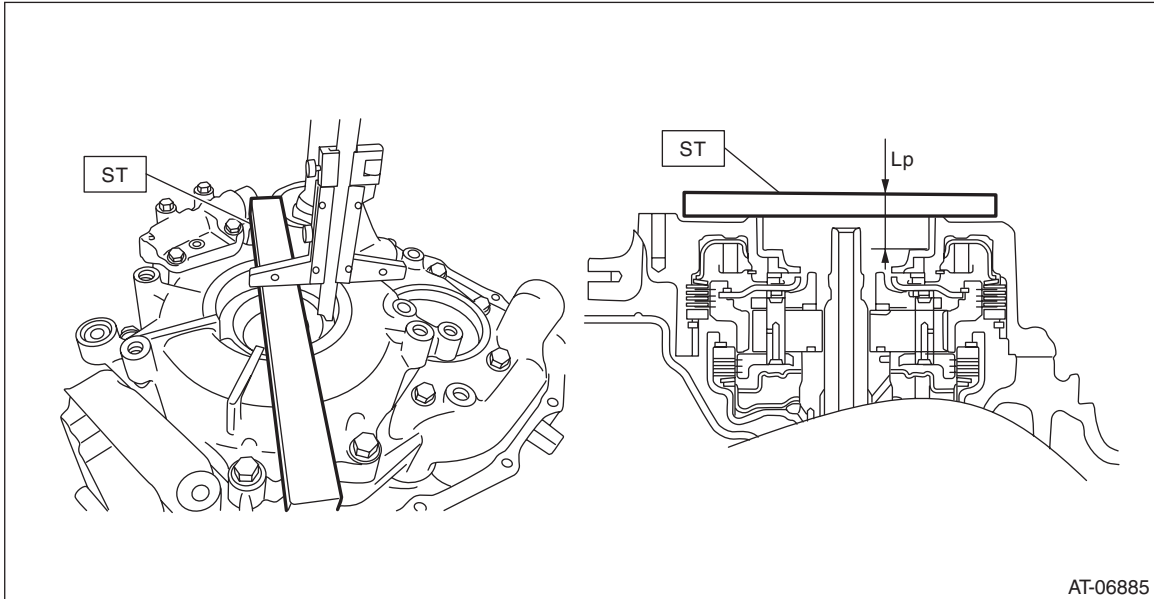

2) Measure the depth "Ls" from the ST upper face to the secondary pulley bearing catch surface at several points and calculate the average.

ST 499575400 GAUGE

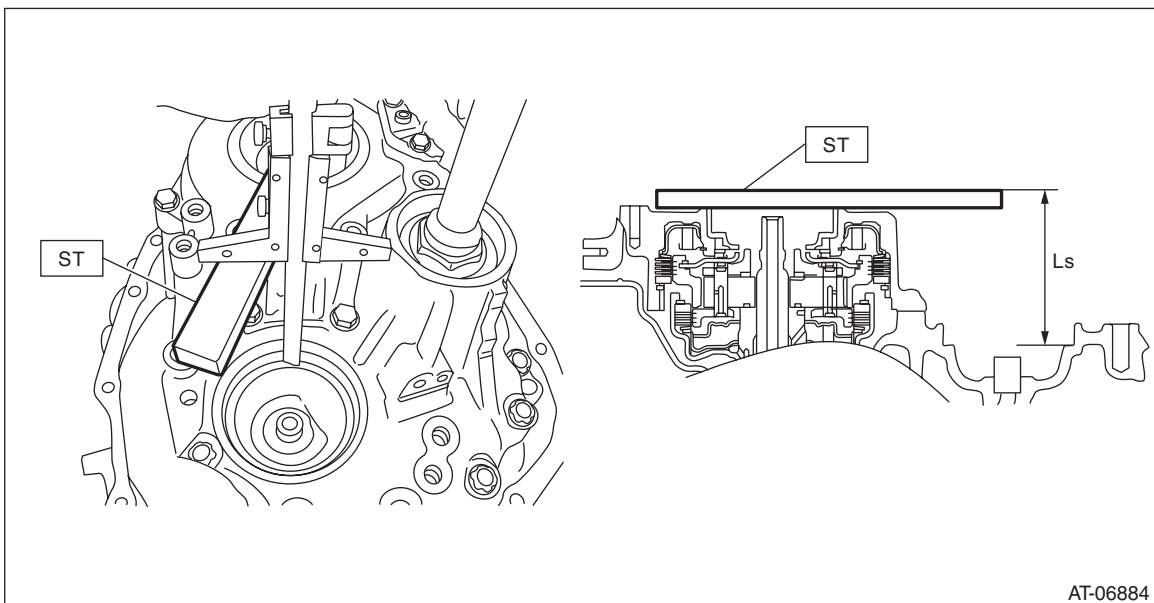

Primary Pulley and Secondary Pulley

CONTINUOUSLY VARIABLE TRANSMISSION

3) Calculate the following formula.

Calculation formula:

$$T \text{ (mm)} = B - A + L_p - L_s - 28.602$$

$$[T \text{ (in)} = B - A + L_p - L_s - 1.126]$$

T: Pulley alignment

A: Specified primary pulley dimension

B: Specified secondary pulley dimension

L_p: Depth from the ST upper face to the primary pulley bearing catch surface

L_s: Depth from the ST upper face to the secondary pulley bearing catch surface

28.602 mm (1.126 in): Constant

Pulley alignment T mm (in)	Thickness of shim mm (in)
-0.05 — 0.049(-0.002 — 0.002)	No shims
0.050 — 0.149(0.002 — 0.006)	0.1 (0.004)
0.150 — 0.249(0.006 — 0.010)	0.2 (0.008)
0.250 — 0.349(0.010 — 0.014)	0.3 (0.012)
0.350 — 0.449(0.014 — 0.018)	0.4 (0.016)
0.450 — 0.549(0.018 — 0.022)	0.5 (0.020)
0.550 — 0.649(0.022 — 0.026)	0.6 (0.024)
0.650 — 0.749(0.026 — 0.029)	0.7 (0.028)
0.750 — 0.849(0.029 — 0.033)	0.8 (0.031)
0.850 — 0.949(0.033 — 0.037)	0.9 (0.035)
0.950 — 1.049(0.037 — 0.041)	1.0 (0.039)
1.050 — 1.149(0.041 — 0.045)	1.1 (0.043)

4) Select one to two shims so that the total thickness meets the value obtained from step 3).

Part No.	Shim thickness mm (in)
32451AA050	0.1 (0.004)
32451AA060	0.2 (0.008)
32451AA070	0.3 (0.012)
32451AA080	0.4 (0.016)
32451AA090	0.5 (0.020)
32451AA100	0.6 (0.024)

Primary Pulley and Secondary Pulley

CONTINUOUSLY VARIABLE TRANSMISSION

2. PROCEDURE WHEN REPLACING ONLY DRIVE PINION RETAINER OR REVERSE BRAKE HOUSING

- 1) Clean the mating surface of current drive pinion retainer and converter case.
- 2) Measure and record the shim thickness that is attached on the current reverse brake housing.
- 3) Using the current drive pinion retainer, measure the depth “Lp1” from the ST upper face to the primary pulley bearing catch surface at several points and calculate the average.

ST 499575400 GAUGE

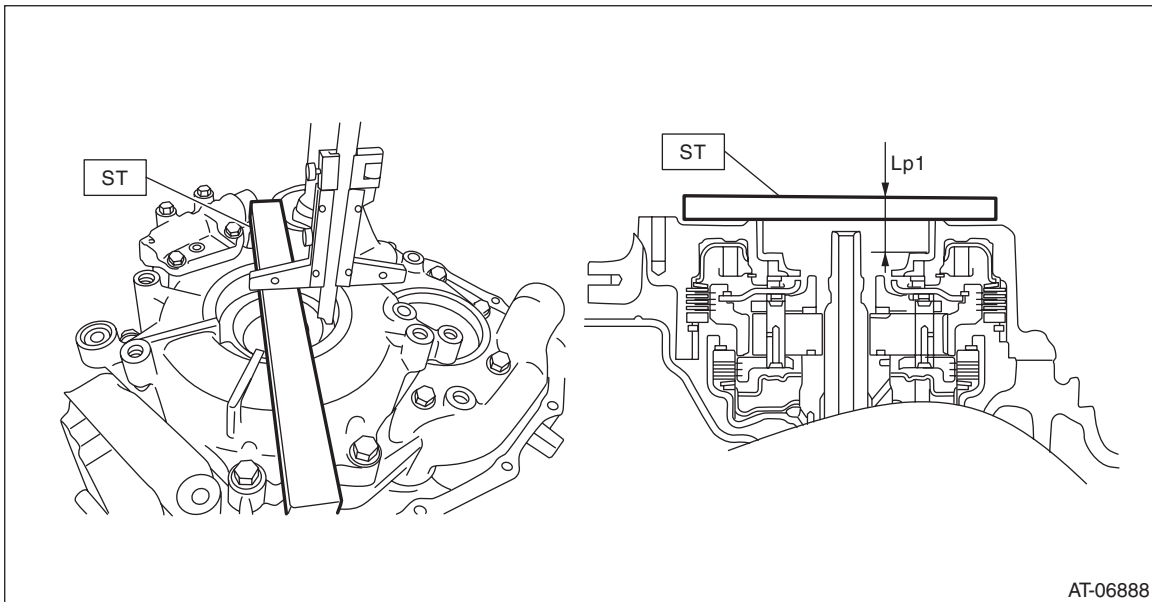

- 4) Using the current drive pinion retainer or current reverse brake housing, measure the depth “Ls1” from the ST upper face to the secondary pulley bearing catch surface at several points and calculate the average.

ST 499575400 GAUGE

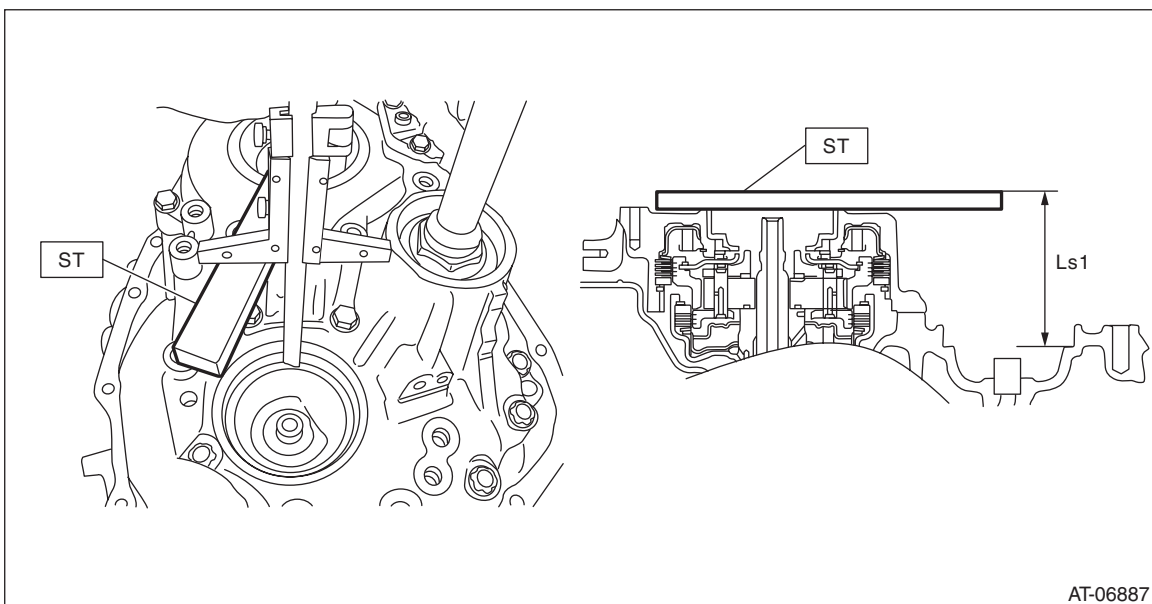

- 5) Calculate the “LD1” using the following formula and record it.

Calculation formula:

$$LD1 \text{ mm (in)} = Ls1 - Lp1$$

LD1: Height from the primary pulley bearing catch surface to the secondary pulley bearing catch surface

Lp1: Depth from the ST upper face to the primary pulley bearing catch surface

Ls1: Depth from the ST upper face to the secondary pulley bearing catch surface

Primary Pulley and Secondary Pulley

CONTINUOUSLY VARIABLE TRANSMISSION

6) Using the new drive pinion retainer or new reverse brake housing, measure the depth “Lp2” from the ST upper face to the primary pulley bearing catch surface at several points and calculate the average.

ST 499575400 GAUGE

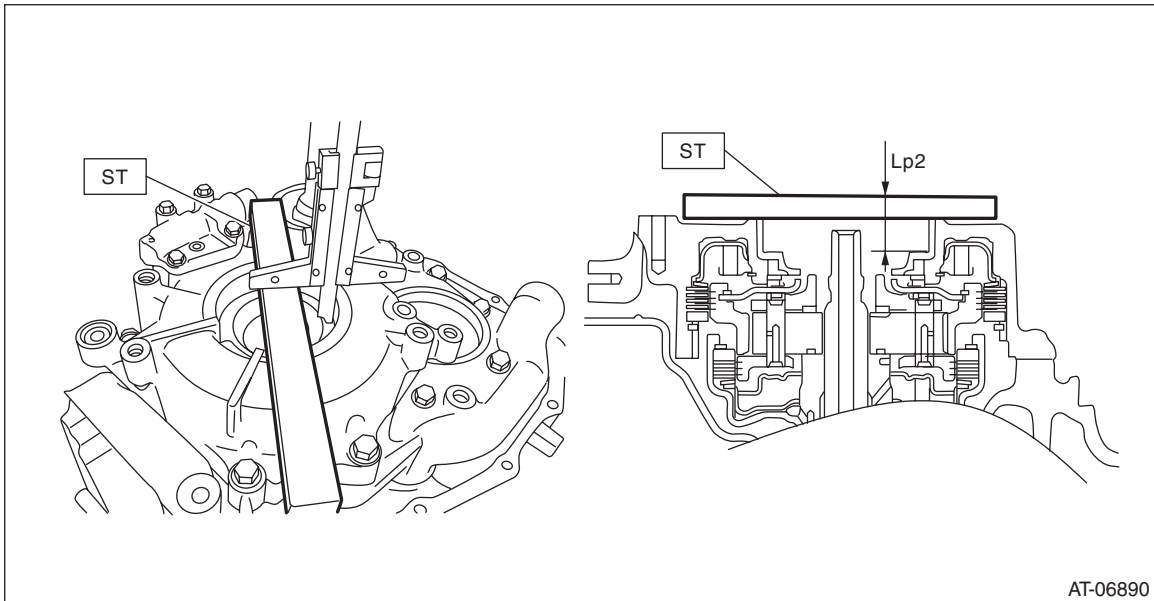

7) Using the new drive pinion retainer or new reverse brake housing, measure the depth “Ls2” from the ST upper face to the secondary pulley bearing catch surface at several points and calculate the average.

ST 499575400 GAUGE

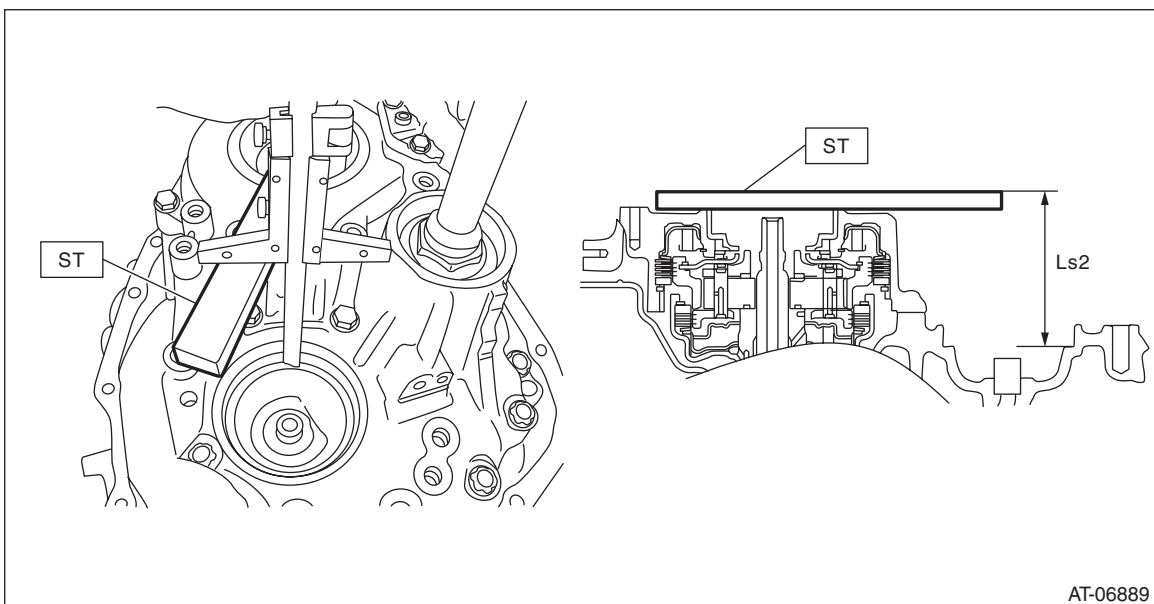

8) Calculate the “LD2” using the following formula and record it.

Calculation formula:

$$LD2 \text{ mm (in)} = Ls2 - Lp2$$

LD2: Height from the primary pulley bearing catch surface to the secondary pulley bearing catch surface

Lp2: Depth from the ST upper face to the primary pulley bearing catch surface

Ls2: Depth from the ST upper face to the secondary pulley bearing catch surface

Primary Pulley and Secondary Pulley

CONTINUOUSLY VARIABLE TRANSMISSION

9) Calculate the recorded values of “LD1” and “LD2” to obtain the positive number to select the shims.

Calculation formula: $T1 \text{ mm (in)} = LD1 - LD2$ or $T2 \text{ mm (in)} = LD2 - LD1$

T1, T2: Difference between new drive pinion retainer or new reverse brake housing and current drive pinion retainer or current reverse brake housing

LD1: Calculated value of current drive pinion retainer or current reverse brake housing

LD2: Calculated value of new drive pinion retainer or new reverse brake housing

Difference of the case (T1) mm (in)	Shim selection procedure
0 — 0.050 (0 — 0.00197)	Select a new shim of the same thickness with the shim that is used on the primary pulley side of the current reverse brake housing.
0.051 — 0.150 (0.00201 — 0.00591)	Select a shim which is 0.1 mm (0.004 in) thicker than the shim that is used on the primary pulley side of the current reverse brake housing.
0.151 — 0.250 (0.00594 — 0.00984)	Select a shim which is 0.2 mm (0.008 in) thicker than the shim that is used on the primary pulley side of the current reverse brake housing.
0.251 — 0.350 (0.00988 — 0.01378)	Select a shim which is 0.3 mm (0.012 in) thicker than the shim that is used on the primary pulley side of the current reverse brake housing.
0.351 — 0.450 (0.01382 — 0.01772)	Select a shim which is 0.4 mm (0.016 in) thicker than the shim that is used on the primary pulley side of the current reverse brake housing.
0.451 — 0.550 (0.01776 — 0.02165)	Select a shim which is 0.5 mm (0.020 in) thicker than the shim that is used on the primary pulley side of the current reverse brake housing.
0.551 — 0.600 (0.02169 — 0.02362)	Select a shim which is 0.6 mm (0.024 in) thicker than the shim that is used on the primary pulley side of the current reverse brake housing.

Difference of the case (T2) mm (in)	Shim selection procedure
0 — 0.050 (0 — 0.00197)	Select a new shim of the same thickness with the shim that is used on the primary pulley side of the current reverse brake housing.
0.051 — 0.150 (0.00201 — 0.00591)	Select a shim which is 0.1 mm (0.004 in) thinner than the shim that is used on the primary pulley side of the current reverse brake housing.
0.151 — 0.250 (0.00594 — 0.00984)	Select a shim which is 0.2 mm (0.008 in) thinner than the shim that is used on the primary pulley side of the current reverse brake housing.
0.251 — 0.350 (0.00988 — 0.01378)	Select a shim which is 0.3 mm (0.012 in) thinner than the shim that is used on the primary pulley side of the current reverse brake housing.
0.351 — 0.450 (0.01382 — 0.01772)	Select a shim which is 0.4 mm (0.016 in) thinner than the shim that is used on the primary pulley side of the current reverse brake housing.
0.451 — 0.550 (0.01776 — 0.02165)	Select a shim which is 0.5 mm (0.020 in) thinner than the shim that is used on the primary pulley side of the current reverse brake housing.
0.551 — 0.600 (0.02169 — 0.02362)	Select a shim which is 0.6 mm (0.024 in) thinner than the shim that is used on the primary pulley side of the current reverse brake housing.

Part No.	Shim thickness mm (in)
32451AA050	0.1 (0.004)
32451AA060	0.2 (0.008)
32451AA070	0.3 (0.012)
32451AA080	0.4 (0.016)
32451AA090	0.5 (0.020)
32451AA100	0.6 (0.024)