

## 44.Oil Pump

### A: REMOVAL

- 1) Remove the transmission assembly from the vehicle. <Ref. to CVT-56, REMOVAL, Automatic Transmission Assembly.>
- 2) Remove the torque converter assembly. <Ref. to CVT-152, REMOVAL, Torque Converter Assembly.>
- 3) Remove the oil pump chain cover. <Ref. to CVT-312, REMOVAL, Oil Pump Chain.>
- 4) Remove the oil pump and the plate.

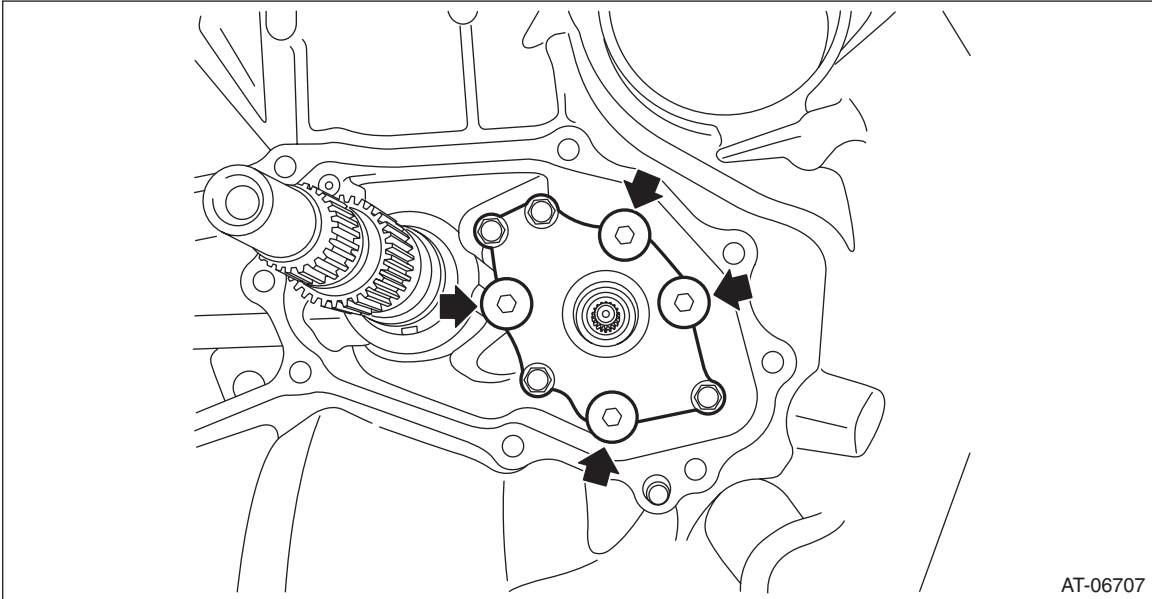

- 5) Remove the O-ring.

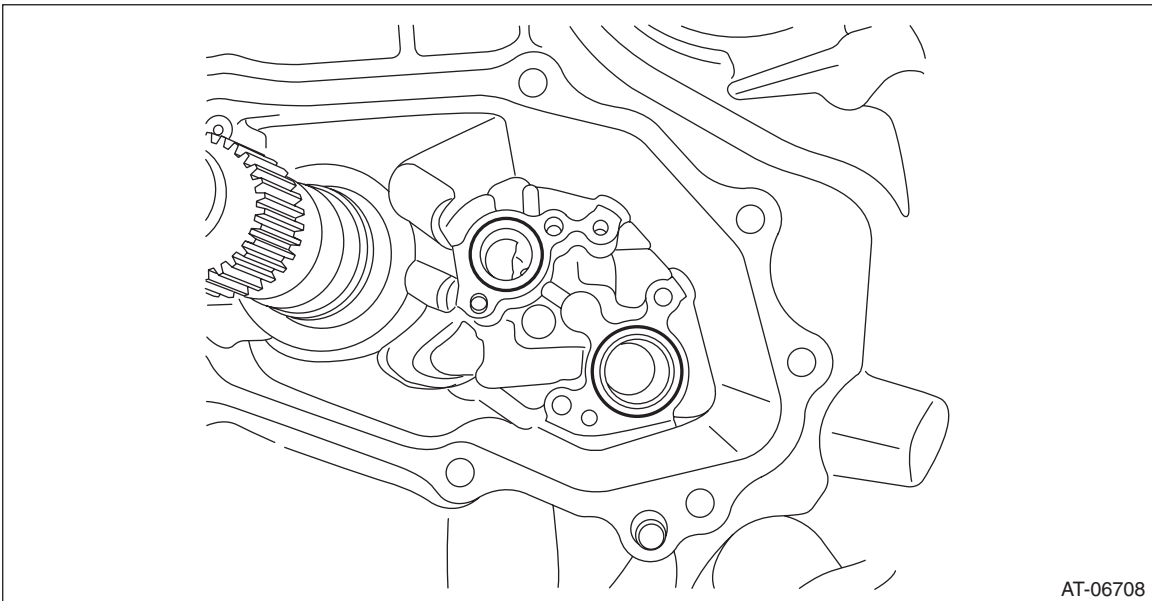

# Oil Pump

## CONTINUOUSLY VARIABLE TRANSMISSION

### B: INSTALLATION

1) Install the O-ring.

NOTE:

- Use new O-rings.
- Apply CVTF to the O-ring.

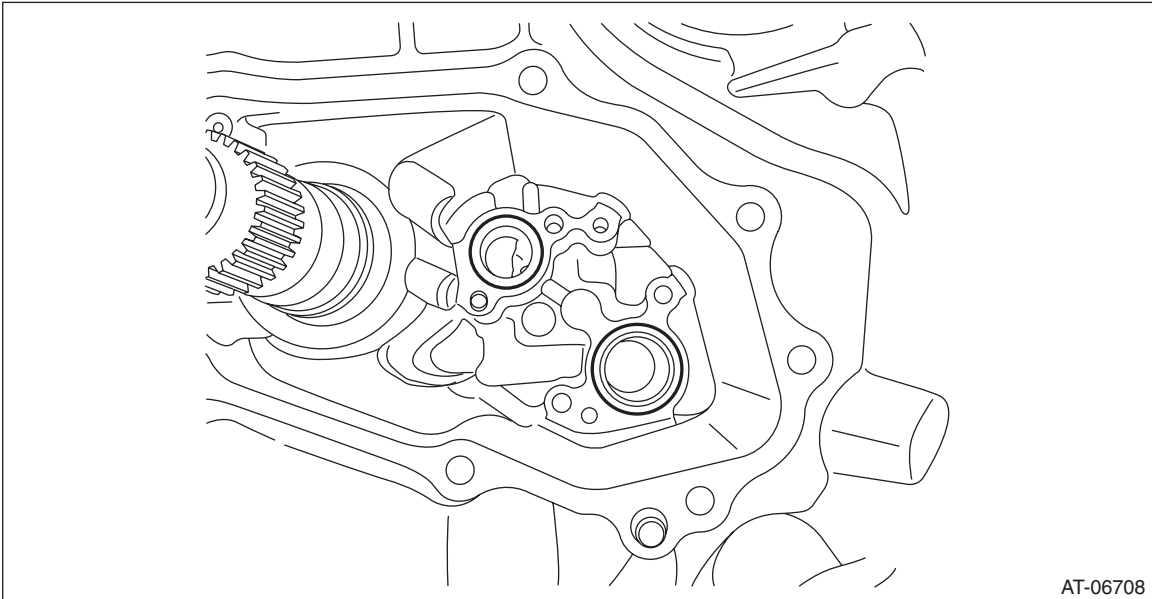

2) Install the plate and the oil pump.

NOTE:

Apply CVTF to the bolt.

**Tightening torque:**

**8.5 N·m (0.9 kgf-m, 6.3 ft-lb)**

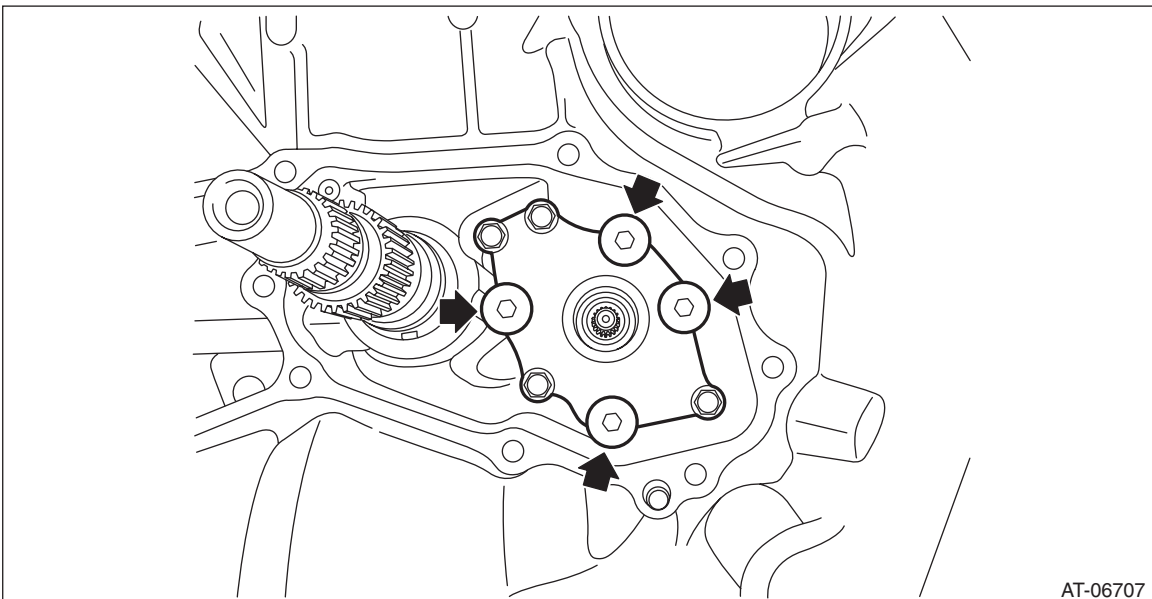

3) Install the oil pump chain cover. <Ref. to CVT-315, INSTALLATION, Oil Pump Chain.>

4) Install the torque converter assembly. <Ref. to CVT-153, INSTALLATION, Torque Converter Assembly.>

5) Install the transmission assembly to the vehicle. <Ref. to CVT-67, INSTALLATION, Automatic Transmission Assembly.>

## **C: INSPECTION**

Check the following items.

- Check the oil pump for damage and wear.
  - Rotate the oil pump by hand, and check that it rotates smoothly.
- 1) Measure the secondary pressure. <Ref. to CVT-47, INSPECTION, Secondary Pressure (Line Pressure) Test.>
  - 2) Remove the oil pan and oil strainer. <Ref. to CVT-110, REMOVAL, Control Valve Body.>
  - 3) Check oil strainer for clogging.
- When oil strainer has no clogging, replace the oil pump.