

3. General Description

A: CAUTION

1. SUPPLEMENTAL RESTRAINT SYSTEM “AIRBAG”

The airbag system wiring harness is routed near the TCM.

CAUTION:

- All the airbag system wiring harnesses and connectors are colored yellow. Do not use an electric test equipment to check these circuits.
- Be careful not to damage the airbag system wiring harness when performing diagnostics or servicing the TCM.

2. MEASUREMENT

When measuring the voltage and resistance of the ECM, TCM or each sensor, use a tapered pin with a diameter of less than 0.64 mm (0.025 in) in order to avoid poor contact. Do not insert a pin of more than 0.65 mm (0.026 in) diameter.

B: INSPECTION

1. BATTERY

Measure the battery voltage and specific gravity of the electrolyte.

Standard voltage: 12 V or more

Specific gravity: 1.260 or more

2. TRANSMISSION GROUND

Make sure that the ground terminal bolt is tightened securely.

Tightening torque:

14 N·m (1.4 kgf·m, 10.3 ft·lb)

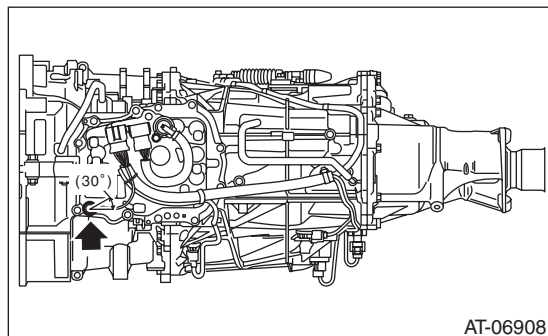

3. OPERATION OF SHIFT SELECT LEVER

Make sure there is no noise, dragging or contact pattern in each select lever range.

WARNING:

Stop the engine while checking operation of the select lever.

General Description

CONTINUOUSLY VARIABLE TRANSMISSION (DIAGNOSTICS)

C: PREPARATION TOOL

1. SPECIAL TOOL

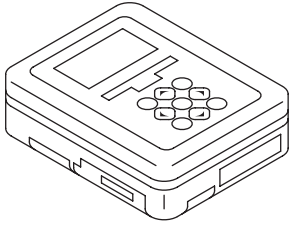
ILLUSTRATION	TOOL NUMBER	DESCRIPTION	REMARKS
 ST1B022XU0	1B022XU0	SUBARU SELECT MONITOR III KIT	Used for troubleshooting the electrical system.

2. GENERAL TOOL

TOOL NAME	REMARKS
Circuit tester	Used for measuring resistance, voltage and current.
Oscilloscope	Used for measuring the sensor.