

Differential Side Retainer Oil Seal

MANUAL TRANSMISSION AND DIFFERENTIAL

6. Differential Side Retainer Oil Seal

A: INSPECTION

Check for leakage of gear oil from differential side retainer oil seal part. If there is oil leakage, replace the oil seal with the new part and check the drive shaft.

B: REPLACEMENT

- 1) Disconnect the ground cable from battery.
- 2) Lift up the vehicle.
- 3) Using the TORX® bit T70, remove the drain plug, and drain the transmission gear oil completely.

CAUTION:

- Immediately after the vehicle has been running or after idling for a long time, the transmission gear oil will be hot. Be careful not to receive burns.
- Be careful not to spill the transmission gear oil on the exhaust pipe, to prevent emission of smoke or causing a fire. If gear oil is spilled, wipe it off completely.

- 4) Tighten the drain plug using TORX® bit T70.

NOTE:

Use a new gasket.

Tightening torque:

44 N·m (4.5 kgf·m, 32.5 ft·lb) (Aluminum gasket silver)

70 N·m (7.1 kgf·m, 51.6 ft·lb) (Copper gasket brown)

70 N·m (7.1 kgf·m, 51.6 ft·lb) (Metal gasket black)

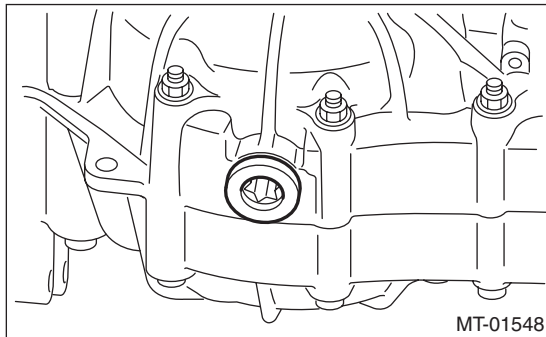

- 5) Remove the center exhaust pipe. <Ref. to EX(H4DO)-14, REMOVAL, Center Exhaust Pipe.>
- 6) Separate the front drive shaft from the transmission. <Ref. to DS-57, REMOVAL, Front Drive Shaft.>

- 7) Remove the differential side retainer oil seal.

NOTE:

- Be sure to replace the differential side retainer oil seal whenever the front drive shaft is removed from the transmission.
- Use the ST 398527700 PULLER ASSY to remove the oil seal. If removing the oil seal with a flat tip screwdriver, be careful not to scratch the differential side retainer.

- 8) Using the ST, install the differential side retainer oil seal by lightly tapping with a plastic hammer.

CAUTION:

- Apply transmission gear oil to the oil seal lips, and install the oil seal while being careful not to deform the lip.
- Check the identification marks (R, L) during the installation so as not to mix up the oil seal RH and LH.

NOTE:

Use a new oil seal.

ST 18675AA000 DIFFERENTIAL SIDE OIL SEAL INSTALLER

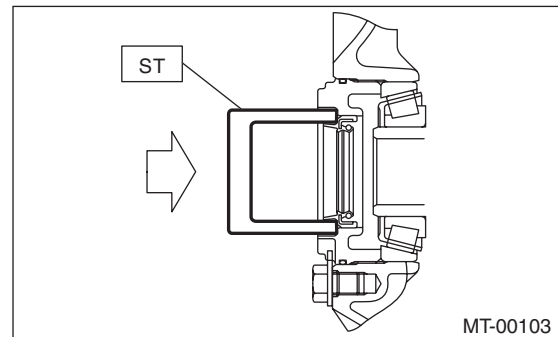

- 9) Install the front drive shaft. <Ref. to DS-59, INSTALLATION, Front Drive Shaft.>

ST 28399SA010 OIL SEAL PROTECTOR

- 10) Install the center exhaust pipe. <Ref. to EX(H4DO)-14, INSTALLATION, Center Exhaust Pipe.>

- 11) Lower the vehicle.

- 12) Pour in transmission gear oil and check the oil level. <Ref. to 5MT-22, REPLACEMENT, Transmission Gear Oil.>

- 13) Connect the battery ground terminal.